VC4 T/R TF4 ISO FDX/HDX

| CONTENTS | | page |
|-----------------|---------------------------------------|-------------|
| 1 | General | 1 |
| 2 | Operation | 1 |
| 3 | Installation | 2 |
| 4 | Set Address | 4 |
| 5 | Adjust antenna | 5 |
| 6 | Adjust Neutrodynisation | 7 |
| 6 | Display values | 9 |
| 7 | Internal test menu | 10 |
| 8 | Trouble shooting | 11 |
| Fig. 1 | Overview TF4 cable connections | 12 |
| Fig. 2 | Display menu | 13 |

1 General

The Transmitter/Receiver Twin Feeder 4 (TF4) is a re-design of the TF2 and can be used for identifying of ISO FDX en HDX responders.

TF4 compared to TF2

The TF4 print is based on the TF2. Cable connections are the same as with a TF2. When using HDX and ISO operation a synchronisation cable must be installed.

Most important change is that FDX and HDX responder types can be identified according to the full ISO standard 11784 and 11785.

EPROM on the T/R TF4

Eproms that are suitable for a TF2 can be used on a TF4. Important is that ISO identification in the software is included. If ISO is possible, the ri menu option is available at responder select.

Caution because of pulsating transmitter (HDX)

Although everything is done to minimize, there is a possibility that the magnetic radiation of the antenna, connected to this reader, influences the behavior of a pacemaker.

Users of a pacemaker are advised to avoid close contact between their pacemaker and the antenna of the TF4

In Germany and Denmark the maximum allowed level is 42 dB μ A /m. at 134.2 kHz. For most other countries in Europe this maximum level is 65 dB μ A/m.

2 Operation

See manual as used for a TF2

3 Installation

The Nedap guarantee-regulations are only valid when the TF4 is installed as indicated in this manual. The following is important :

Technical specifications Twin Feeder 4

| | |
|--|---------------|
| Input voltage | 22-42 VDC |
| Max. current per output (motors) | 3A DC |
| Operating temperatures (environment) | -10°C / +45°C |
| Transport / storage temperatures | -25°C / +70°C |
| Humidity (rh) | 45% / 93% |
| Enclosure protection class (cover and cables installed correctly !) | IP65 |



Always use a NEDAP SMPS power supply
Never change a prom when the power to the T/R is still switched on
Install data cables at a safe distance from (high) powered cables

Wiring the TF4

Figure 1 shows an overview of the T/R TF4 cable-connection.

Cable specifications

Cable length at power supply 27V:

| | |
|---|--|
| IB → TF4 | Max. 40m at wire- \varnothing = 0.8 mm |
| TF4 → motor | Standard cable of the motor |
| TF4 → antenna | Standard cable of the antenna |
| Synchronisation (HDX and ISO operation) | Twisted pair minimum 2x0.24mm ² shielded. Total max. 500m |

IMPORTANT: All cables used for data communication must have shielding!

Hardware motor safeguard

When the micro processor has no control over the T/R anymore and a motor is running uncontrolled and keeps turning continuously, a hardware circuit on the T/R will stop the motor by means of a relay (25 seconds (+/- 5 sec)). This motor safeguard can only be reset by switching off the power from the T/R for a few seconds.

Software motor safeguard

This software function monitors the motor current. If a motor current is detected which is too high ($I_{\text{motor}} > 900 \text{ mA}$) for a certain time, the T/R program will try to stop the motor. If the motor can not be stopped, the T/R program will shut off the power supply on all outputs.

Synchronisation for HDX

A synchronisation cable is necessary for HDX to synchronise T/Rs that can influence each other. For FDX only (jumper set to FDX only) synchronisation is not necessary.

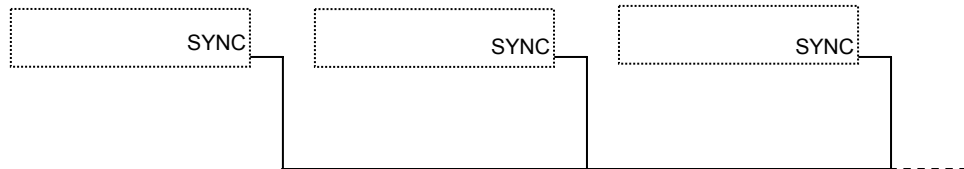

The connector at the right hand side (SYNC) contains a synchronisation signal for HDX (SYNC). SYNC has to be connected to all other HDX readers in the neighbourhood. There is no + or -. Maximum number is 16 that can be connected together for synchronization. If a cable is used with shielding, the shielding must not be connected at the bottom plate of the PCB but left as not connected.

Jumper for FDX / HDX or FDX only

If set to FDX / HDX the red led is blinking during transmitting the synchronisation signal.

When set to FDX only, the red led remains off.

LEDs

The three leds are used for tuning the antenna.

The two leds are for identification (green) and synchronisation (red).

Shielding, grounding

In order to protect the TF4 for over-voltages / induction, the cable from the interface bridge to the TF4 must be a shielded cable. Connections:

| | |
|-------------------------------|------------------------------|
| interface bridge | connected to "-"terminal |
| Transmitter / Receiver | connected to ground-terminal |

N.B. All T/R electronics must be isolated. Also the T/R bottom plate has to be isolated from the T/R ground-terminal.

Warnings

- Due to guarantee-regulations, the entire T/R PCB (incl. metal plate) must be changed.

4 Set Address

For communication the Transmitter / Receiver needs an address. Then the computer knows where to send the information to. At the transmitter / receiver with help of the display and the push button the stations address is configured.

The two segment display and the yellow push-button must also be used for several adjustments of the Transmitter / receiver. A number of different codes will appear on the display when the push-button is pushed, these codes represent the so-called menus. Each menu on its turn is divided into a number of functions. By varying the pushing time of the push-button, you will get access to the different menus and/or functions.

The first time you switch on the power of the T/R, the display will show "0-". The Transmitter / Receiver asks now for the first address. When an address is entered the display will blank out and the transmitter / receiver returns to the normal status.

The address setting concerns the following menus and procedures (see figure 3):



- **Address menu**
 - **S**et **A**ddress
 - **d**isplay **A**ddress

N.B. Remember that the used peripheral-address has to be unique on a channel.

Changing addresses



When the display shows **SA**, the "**S**et **A**ddress procedure" is entered by pressing the button until the display blinks. The procedure is as follows :

set decimal-digit display scrolls from **0-** through **1-**
set unit-digit display scrolls from **x0** through **x9**

- to indicate that the "**S**et **A**ddress procedure" has been entered, the display will show "**0-**"
- by pressing the button short, the next decimal will be displayed ("**1-**")
- the displayed decimal is entered by pressing the button until the display blinks
- when the decimal has been entered, the display will show "**x0**" (where **x** = entered decimal), the unit-digit now can be entered
- by pressing the button short, the next unit will be displayed ("**x1**", "**x2**", .. , "**x9**")
- the displayed unit is entered by pressing the button until the display blinks

The following points should be noted

- the "**S**et **A**ddress procedure" can be quit by pressing the button until the display blanks. The entered digits then are not stored
- the T/R will restart when the address is changed

Show addresses



When the display shows **dA**, the "**d**isplay **A**ddress procedure" is entered by pressing the button until the display blinks. The display then shows the T/R address.

5 Adjust antenna

The antenna adjustment has to be done with help of the display, push button, potentiometer (P1) and a coil (L404) on print (or EWA transformer when using external antenna).

Most eeproms have following HF-menu :



HF menu

- | | |
|-------------------------|--|
| Responder Select | <ul style="list-style-type: none">• selection of responder type |
| Adjust Antenna | <ul style="list-style-type: none">• not used |
| Adjust Power | <ul style="list-style-type: none">• adjust transmitter-power by means of potentiometer P1 |
| Adjust Squelch | <ul style="list-style-type: none">• adjust receiver-sensitivity (0,1,2,3) |
| Identification | <ul style="list-style-type: none">• test identification |

⇒

The antenna adjustment-procedure consists of several steps. It is essential that these steps are executed in the sequence as in the manual described.

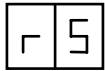

Responder Select

rA = not used

rP = not used

ri = 134.2 kHz ISO responders

Select rS on the display and then ri, press until display blinks to enter.

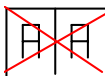

Adjust antenna procedure

The AA-menu option is not used for the TF4. Tuning of the antenna is done with a trimmer on the print (Ct) when using an internal antenna. When using an external antenna (with EWA transformer) the coil on the EWA transformer (Lt) must be used. Three LEDs next to P1 are used as indication for the tuning.

Tuning:

Set the antenna field on with id.

Turn the trimmer (Ct) until the green LED is on.

- | | | | |
|-------------------------------------|-------------------------------------|-------------------------------------|--|
| <input type="checkbox"/> | <input checked="" type="checkbox"/> | <input type="checkbox"/> | Antenna correct adjusted |
| <input type="checkbox"/> | <input type="checkbox"/> | <input checked="" type="checkbox"/> | Antenna impedance to high, turn to the left |
| <input checked="" type="checkbox"/> | <input type="checkbox"/> | <input type="checkbox"/> | Antenna impedance to low, turn to the right |
| <input checked="" type="checkbox"/> | <input type="checkbox"/> | <input checked="" type="checkbox"/> | LEDs blinking : antenna error or antenna not tuned |
| <input type="checkbox"/> | <input type="checkbox"/> | <input type="checkbox"/> | LEDs switched off : transmitter not switched on |

The next step is tuning the power with AP.



Power adjustment

After correct processing the antenna adjustment procedure, **P1** (fig1) must be adjusted with help of AP.

Power adjustment is used to set the ID distance. By reducing the power the reading distance will be smaller. Power adjustment is done with a potentiometer (P1).

Changing the power level:

Select with the push button the AP-menu (adjust power) and press until the display starts to blink. A value appears on the display now. Turn P1 till the desired reading distance of the ID label. Maximum power is 99.

After changing the power level always check if the green antenna tuning LED is still on.



Adjust squelch

The adjusted squelch determines the sensitivity of the receiver in the T/R. In case e.g. animals outside the antenna are identified, the transmitted power can be reduced ("Adjust Power procedure") or the receiver-sensitivity can be reduced by means of the squelch-adjustment.

Normally squelch does not have to be adjusted (automatically set to default)

When the display shows **AS**, the "Adjust Squelch procedure" is entered by pressing the button until the display blinks. The display now shows the actual sensitivity of the receiver, a value from "-0" (most sensitive) "-1", "-2" or "-3" (less sensitive).

By shortly pressing the button, the desired squelch can be adjusted. The setting can be entered by pressing the button until the display blinks.

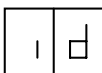

Test identification

The HF-field is now continuously active, switching between HDX or FDX responders, when both types are present at the antenna.

ID-status:

-- = no responder identified

xx = responder identified (xx = last two digits of responder number)

6 Adjust Neurodynamisation

Why using a neurodynamisation unit

When two large antennas are used in a small area, a responder identified in one antenna, is also identified in the other antenna (cross talk). Installing a neurodynamisation unit can solve this problem

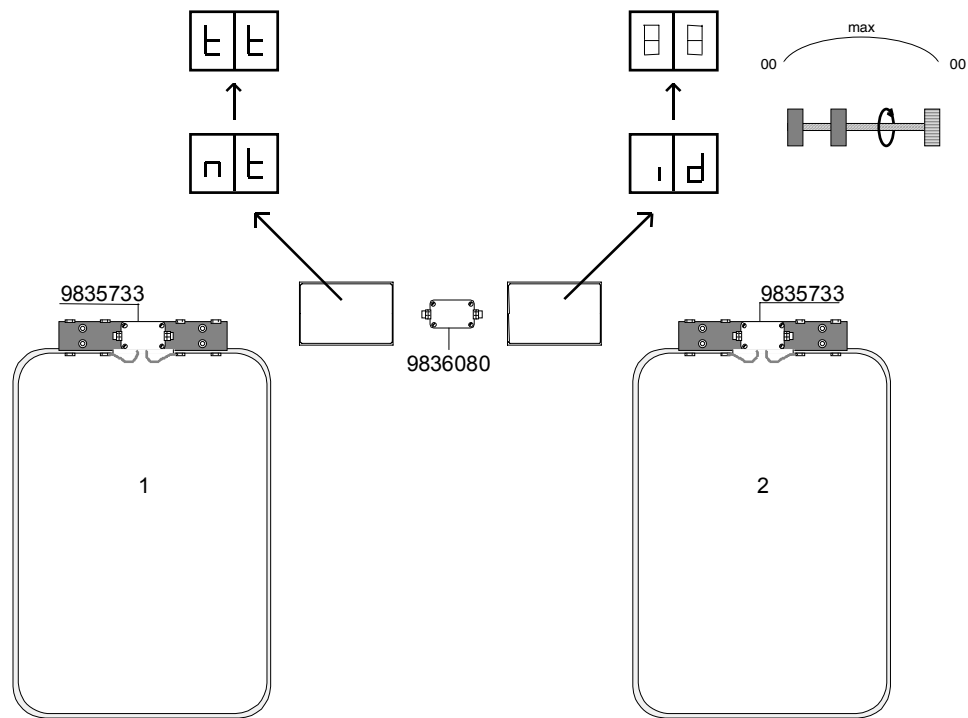

Figure : Twin Feeder model 4 with neurodynamisation

Principle of neurodynamisation

The neurodynamisation-unit is a small version of the big antennas. The two coils in the box are connected to the antenna's. By moving the coils the "cross talk problem" between both antennas can be solved.

Tuning principle: one of the T/R is set to transmitting (tt). The other one is set to identification (id). The transmitter will give a very strong signal. The receiver will translate the received signal strength into a display value. A value around 10 means cross talk.

Wiring Neuro - EWA transformer

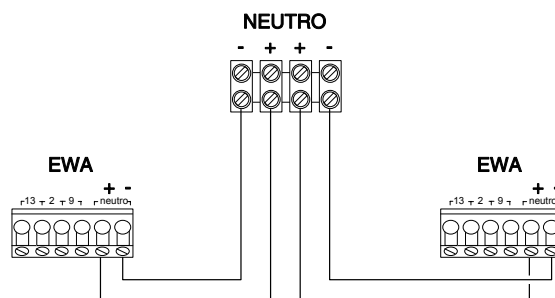

Adjustment of the neutrodynisation unit

Twin Feeder model 4

IMPORTANT : Always use a synchronisation cable between both T/R.

1. Switch on the power to the system
2. Position both neutrodynisation-coils close to each other, but not touching
3. Antenna 1 :
Select "An" on the display, then "nt", press until display blinks. The display now shows "tt" (transmitting)
Antenna 2 :
Select "id" on the display, press until display blinks. The display now shows a numeric value (receiving)
4. Using the TF display :
Start turning the neutro wheels from each other. The value on the display of antenna 2 will increase. Keep on turning until the highest value appears (see graph).
5. The neutrodynisation is now finished. It is important to do a final check.
Select the "id" menu. Set both antennas in "id" position.
Move a responder in the middle of antenna 1 (about 40-50 cm from the floor).
When the display of T/R 2 does not show the responder number, the adjustment is OK.



TF 4 Display neutrodynisation values explained in a graph

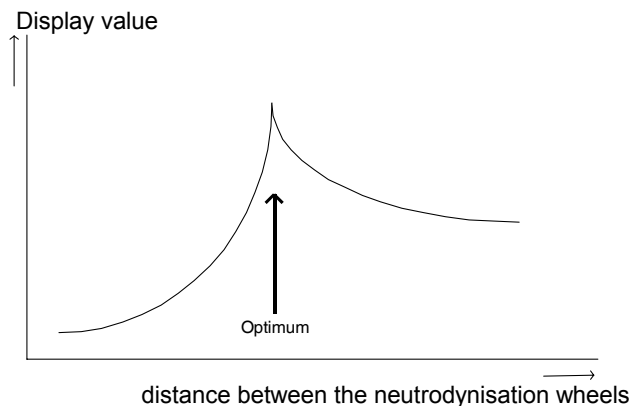

Trouble shooting when tuning the neutrodynisation unit

- The display does not reach a peak value when tuning
Wiring twisted (when a plus and minus in the antenna system is changed there will be no peak in tuning the neutro)
- The display starts already with a high value and does almost not increase
There is almost no cross talk, the receiver can not or almost not detect a signal coming from the transmitter

6 Display values

During operation, the program steps through different program-states which are monitored on the display. This gives information about the state of the T/R and therefore can be used as an extra service tool.

The indication on the display is as follows :

Start process

| status | description of the status |
|--------|--|
| 00 | start : processor-initialisation |
| 01 | wait for valid address, "SA"-menu is started automatically |
| 02 | No communication with a process computer |
| 03 | No communication with a process computer |
| 04 | T/R TF under test |
| 05 | start-up process finished |

Display values during operation

See manual as used for a TF2

7 Internal test menu

The Internal test menu is a powerful service tool in case of system-service. The T/R stores registered errors which can be displayed on demand of the trouble-shooter. Also the T/R can execute a complete self test on demand, the test results also are displayed.



Internal test menu

- display Error procedure
- Self test menu : see figure 2



Display error procedure

The detected errors are stored by the T/R itself and can be monitored on the display. Two types of messages can be displayed by the T/R :

- error-messages (E1)
- warning-messages (E2, not used yet)

The procedure shows all registered errors on the display, one after the other, proceeded by the message-type. First all error-messages will be shown, then all warning-messages.

| error | description | how to handle |
|-------|---|---|
| -- | no errors | |
| 01 | error detected in output 1 | perform self test output 1 |
| 02 | error detected in output 2 | perform self test output 2 |
| 03 | error detected in output 3 | perform self test output 3 |
| 04 | error detected in output 4 | perform self test output 4 |
| 07 | <u>output hardware error :</u> <ul style="list-style-type: none"> • no outputs were active, yet a output current is detected • power supply to outputs then is switched off : <ul style="list-style-type: none"> - if output current remains detected, T/R will restart - if output current now is 0, T/R status remains unchanged | <u>possible cause(s) :</u> <ul style="list-style-type: none"> • one or more motor-outputs defect • uProc A/D-converter defect <u>solution :</u> <ul style="list-style-type: none"> • switch power supply off and on again • if any outputs are running unauthorised, outputs are defect, replace T/R PCB • if T/R continuously restarts, the A/D-converter is defect. Replace T/R -PCB |
| 08 | <u>output watchdog activated :</u> <ul style="list-style-type: none"> • software detects that output runs > 15 seconds (unauthorised) • T/R restarts | <u>possible cause :</u> <ul style="list-style-type: none"> • unknown, probably software-error |
| 09 | <u>Antenna error :</u> <ul style="list-style-type: none"> • no or low HF-current detected | <u>possible cause(s) :</u> <ul style="list-style-type: none"> • antenna not connected or wrong adjusted <u>solution :</u> <ul style="list-style-type: none"> • check antenna / tune antenna • check HF-field • replace T/R-PCB |
| 11 | <u>RAM error at start up :</u> <ul style="list-style-type: none"> • data written does not match data read | <u>solution :</u> <ul style="list-style-type: none"> • replace T/R-PCB |
| 12 | <u>ROM error at start up :</u> <ul style="list-style-type: none"> • calculated checksum does not match checksum of EPROM | <u>solution :</u> <ul style="list-style-type: none"> • replace T/R-PCB |

8 Trouble shooting

| Symptom | cause | solution |
|--|---|---|
| <ul style="list-style-type: none"> T/R TF does not start up, display remains blank | <ul style="list-style-type: none"> no power | <ul style="list-style-type: none"> check wiring |
| | <ul style="list-style-type: none"> prom wrong installed | <ul style="list-style-type: none"> check prom |
| <ul style="list-style-type: none"> T/R TF does not start up, display shows "E1", "E2" or "E3" | <ul style="list-style-type: none"> RAM, ROM or both failed | <ul style="list-style-type: none"> replace T/R TF |
| <ul style="list-style-type: none"> T/R TF does not start up, display shows "02" or "03" | <ul style="list-style-type: none"> T/R TF remains in start-up process, no communication with a process computer | <ul style="list-style-type: none"> check T/R TF address and other settings check wiring |
| <ul style="list-style-type: none"> Poor identification | <ul style="list-style-type: none"> antenna badly adjusted | <ul style="list-style-type: none"> perform identification self test, check reading-distance and check if green adjustment LED is on if reading-distance constantly poor, readjust antenna or enlarge transmitting-power P1 |
| | <ul style="list-style-type: none"> HDX synchronisation not ok | <ul style="list-style-type: none"> check all jumpers, wiring |
| | <ul style="list-style-type: none"> disturbance by: <ul style="list-style-type: none"> - computer/monitor - television - frequency controlled motors - tube lamps - LW radio transmitters | <ul style="list-style-type: none"> switch possible disturbance off (when possible) and when the cause is found take action to reduce the disturbance |
| <ul style="list-style-type: none"> FDX is working ok, HDX not | <ul style="list-style-type: none"> one or more jumpers set to FDX only | <ul style="list-style-type: none"> set jumpers correctly |
| | <ul style="list-style-type: none"> 120 kHz system in the neighbourhood activ | <ul style="list-style-type: none"> switch 120kHz system off to check |
| <ul style="list-style-type: none"> All antenna leds off | <ul style="list-style-type: none"> HF not switch on | <ul style="list-style-type: none"> switch HF on in the software |
| <ul style="list-style-type: none"> Two red antenna leds blinking | <ul style="list-style-type: none"> antenna alarm | <ul style="list-style-type: none"> - antenna defect - antenna no adjusted - short circuit or open antenna wire connection |

TWIN 4

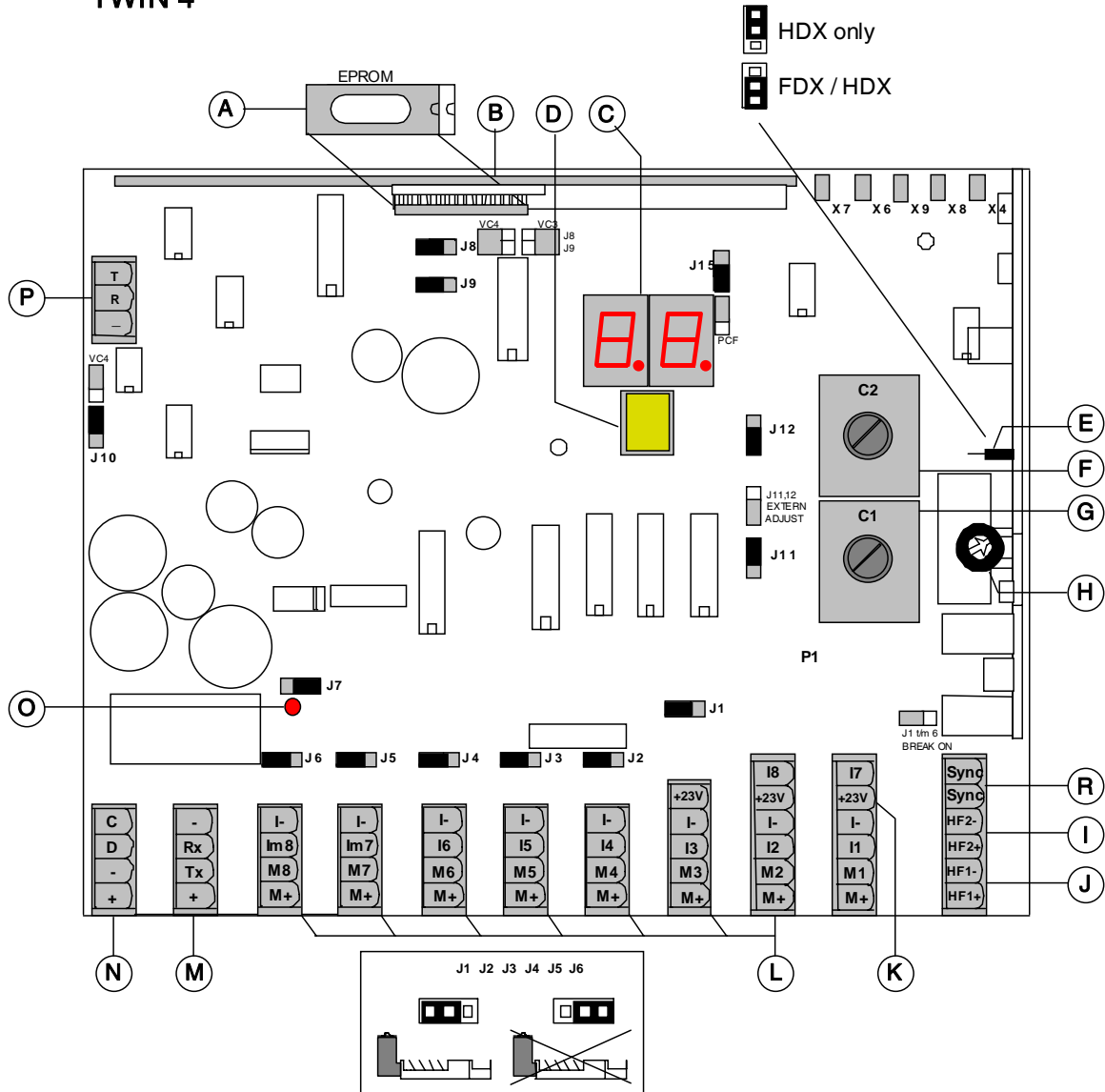

- | | | | |
|----------|-----------------------------|------------|--|
| A | EPROM | O | LED "motor hardware safeguard" disabled |
| B | Micro processor module | P | RS232 connector |
| C | Display's | R | Synchronisation |
| D | Push button | J1 | J1 - J6 "Enable brake" jumpers |
| E | Jumper FDX/HDX or FDX only | J7 | Jumper "motor hardware safeguard" on/off |
| F | HF trimmer antenna 2 (C2) | J8 | J8 - J9 jumpers VC3 - VC4 |
| G | HF trimmer antenna 1 (C1) | J10 | Jumper VC3 - VC4 communication channel |
| H | HF power potentiometer (P1) | J11 | J11 - J12 Jumper HF1 and HF2 |
| I | Connector antenna 2 | J15 | Jumper Phase code ID on/off |
| J | Connector antenna 1 | X7 | Signal ground |
| K | + 23 Volt | X6 | Responder signal |
| L | Input / output connectors | X9 | TP2 |
| M | VC3 connector | X8 | TP1 |
| N | VC4 connector | X4 | AGC |

Fig. 1 Overview TF4 cable connections

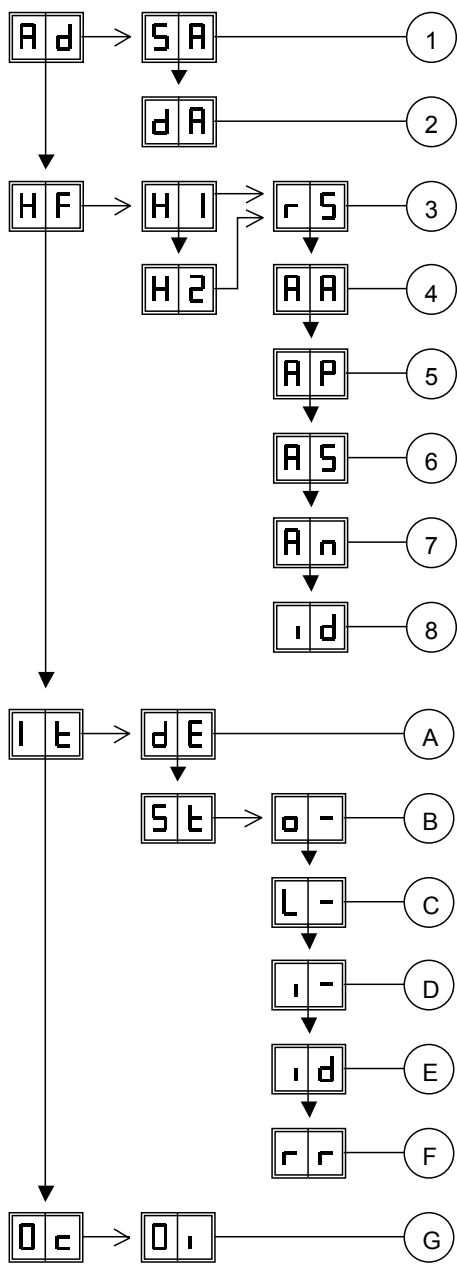

Fig. 2 Display menu

General overview, menu can be different for prom types and versions

1. Set Address
 2. Display Address
 3. Responder select ri (iso)
Prom can not be used when ri is not available
 4. Adjust Antenna, not used
 5. Adjust Power
 6. Adjust Squelch, not used
 7. Not used
 8. Test identification
- A. Display errors
 - B. o1 motor output 1
o2 motor output 2
o3 motor output 3
o4 motor output 4
 - C. L1 output 1 (relais)
L2 output 2 (relais)
L3 output 3 (relais)
L4 output 4 (relais)
 - D. i1 input 1
i2 input 2
i3 input 3
i4 input 4
 - E. Test identification
 - F. ROM/RAM test / reboot
E1 ram error
E2 rom error
E3 ram and rom error
 - G. Output installation

| | | | |
|---|------------------------------|----|--|
| → | Press button untill blinking | ☐☐ | To leave menu: press button untill display is empty |
| ↓ | Press button short | | |