

TRANSIT EDGE WIRELESS

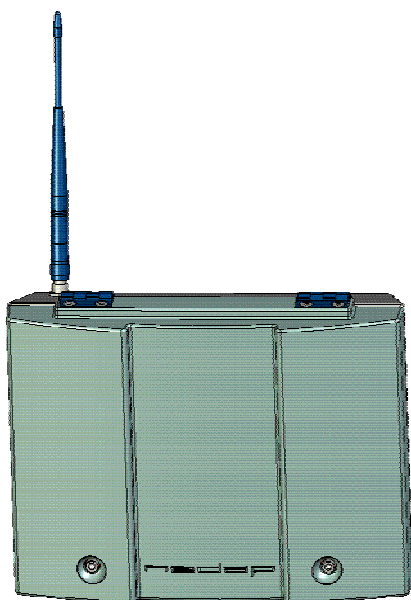

2008-11-18

Part # : 5268664

This information is furnished for guidance, and with no guarantee as to its accuracy or completeness; its publication conveys no license under any patent or other right, nor does the publisher assume liability for any consequence of its use; specifications and availability of goods mentioned in it are subject to change without notice; it is not to be reproduced in any way, in whole or in part, without the written consent of the publisher.

CONTENTS



1	Introduction	3
2	System diagram.....	4
3	Wiring diagram.....	5
4	Contact Information	6
5	FCC Declarations.....	7
	Appendix	8
	A.1 Specification TRANSIT	8
	A.2 Specification AW900mT	8
	A.3 Specification EDGEPLUS SOLO ES400	8

1 Introduction

Thank you for your purchase of the NEDAP TRANSIT EDGE WIRELESS system. Nedap AVI manufactures some of the most reliable readers on the market today. Specializing in long range automatic vehicle identification, Nedap's readers are able to identify both the vehicle and driver up to 33' and at speeds up to 125 mph!

The TRANSIT EDGE WIRELESS, a long range reader, showcases specially developed technology from both HID and AvaLan wireless to provide a powerful web accessible reader at your perimeter.

The NEDAP TRANSIT EDGE WIRELESS part no (9876790) exists of the following main components.

- TRANSIT NEDAP USA
- EDGEPLUS SOLO ES400 
- AW900mT (Client at entrance/gate) 
- AW2 antenna

The Base station for the connection at your network exists of the following components.

- AW900iT part no (9877010) (wireless access point at network connection) 
- AW2 antenna

The functional main components are described in the Block diagram below.

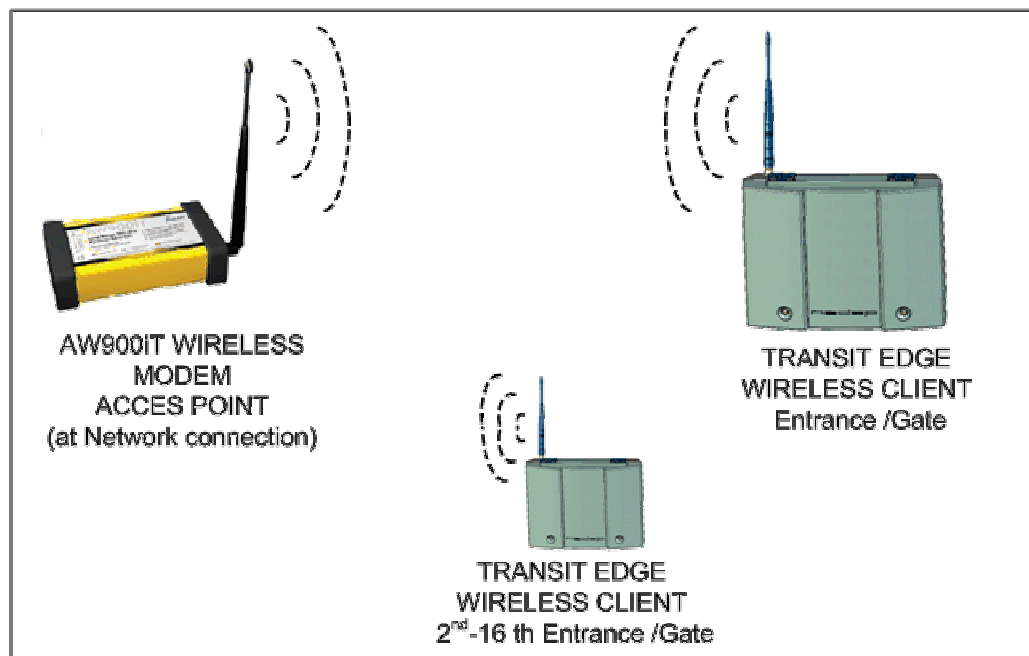

2 System diagram

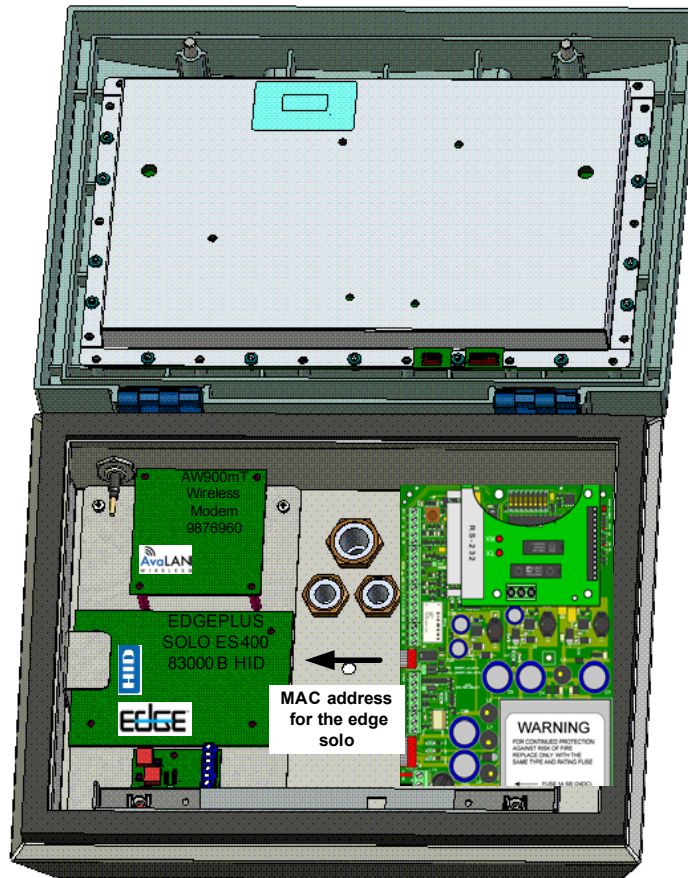

The TRANSIT EDGE WIRELESS is complete wired up and ready for use. You have only to follow the next steps.

- Install the TRANSIT EDGE WIRELESS according to the TRANSIT manual and the quick reference. Put also the included AW2 antenna on the top of the unit.
- Power up the TRANSIT EDGE WIRELESS with a **24 VDC 2A power supply**.
- Perform initial setup as described in the Quick start guide (AW900T User's Manual Supplement) and the AW900mT. (USER'S MANUAL)
- Check with the aid of the LED,s from the access and subscriber if the link is available. **Tip you can use the Ethernet cable between the modem and the edge to share the network keys.**
- Restore the connections after sharing the network keys and power down and up the TRANSIT EDGE WIRELESS and the base station.
- Connect the Edge Plus wiring according to the Installation Guide P/N 82000-902-ENEN.

- To configure and communicate with the Edge Plus use the Quick Installation Guide. (Document number 82000-901A.20).

3 Wiring diagram

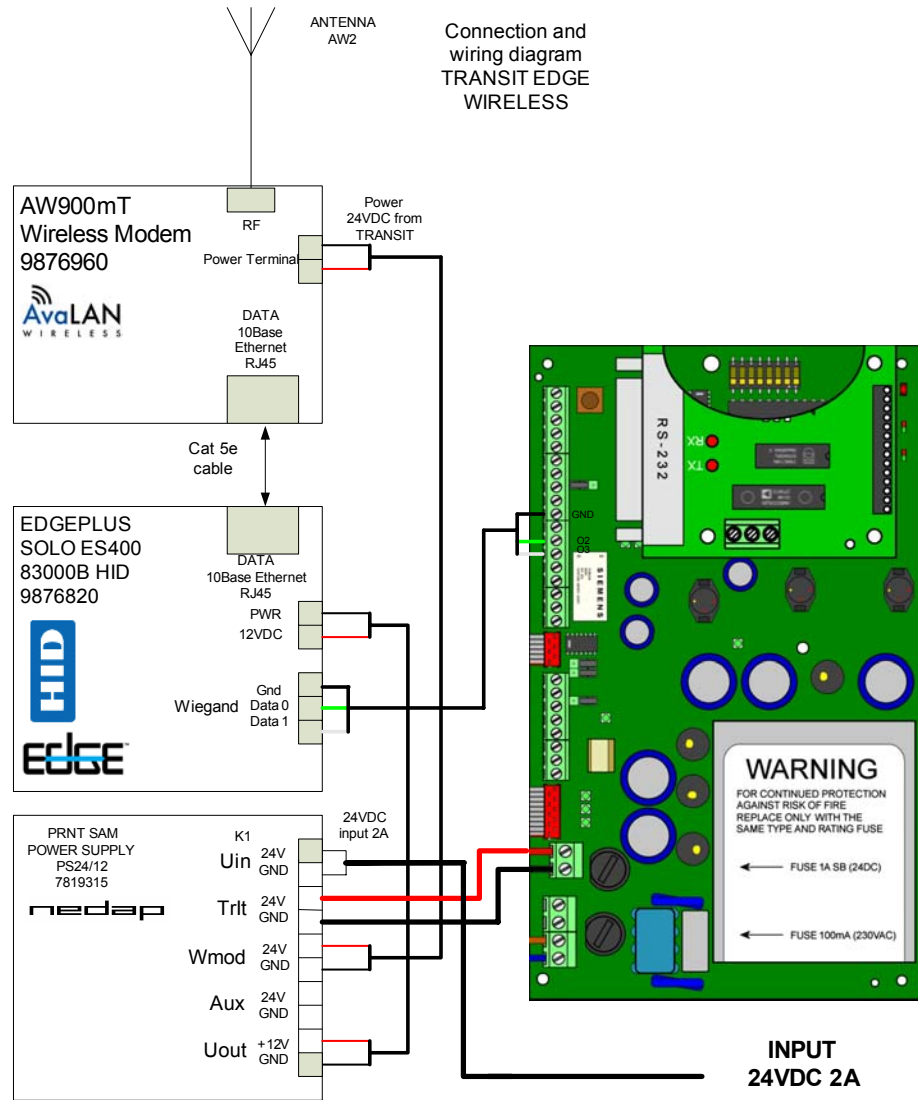

The diagram above shows schematically the internal connection between the used modules.

The Main connections are:

- TRANSIT
 - TRANSIT Wiegand output to the EdgePlus Module.
 - 24VDC Power connection to the PS24/12 Power Supply
- Edge Plus module
 - Power connection to PS24/12 Power Supply
 - Wiegand Input from TRANSIT
 - Ethernet Cable from AW900mT module
- AW900MT Module
 - Ethernet cable from Edge plus Module

- Power connection to PS24/12 Power supply
- Antenna cable to AW2 Antenna

4 Contact Information

If you have any questions when configuring your TRANSIT EDGE WIRELESS

Please contact:

Curtis Dennis
NEDAP AVI
Tuxen & Associates. Inc.
Exclusive Agent – The Americas
Phone: 417-339-4730 ext. 101
e-mail: cdennis@tuxen.us
web: www.nedapavi.com

If you have any questions when configuring your HID edge system.

Please contact:

HID Global (California, USA)
Support: support_na@hidvertx.com
Sales: sales@hidvertx.com
Main: (949) 598-1600
Sales: (800) 210-4744
Telephone 1-800-237-7769
Fax number: (949) 598-1690

If you have any questions when configuring your AvaLan system

Please contact:

Technical support: (650) 384.000
e-mail: support@avalanwireless.com
web: www.avalanwireless.com

5 FCC Declarations

Compliance statement (part 15.19)

This device complies with part 15 of the FCC Rules and to RSS210 of Industry Canada.

Operation is subject to the following two conditions:

- (1) this device may not cause harmful interference, and
- (2) this device must accept any interference received, including interference that may cause undesired operation.

Warning (part 15.21)

Changes or modifications not expressly approved by the party responsible for compliance could void the user's authority to operate the equipment. This in particular is applicable for the antenna which has been delivered with the TRANSIT EDGE WIRELESS.

RF Exposure (OET Bulletin 65)

To comply with FCC RF exposure requirements for mobile transmitting devices, this transmitter should only be used or installed at locations where there is at least 20cm separation distance between the antenna and all persons.

Information to the User (Part 15.105 (b))

Note: This equipment has been tested and found to comply with the limits for a Class B digital device, pursuant to part 15 of the FCC Rules. These limits are designed to provide reasonable protection against harmful interference in a residential installation. This equipment generates, uses and can radiate radio frequency energy and, if not installed and used in accordance with the instructions, may cause harmful interference to radio communications. However, there is no guarantee that interference will not occur in a particular installation. If this equipment does cause harmful interference to radio or television reception, which can be determined by turning the equipment off and on, the user is encouraged to try to correct the interference by one or more of the following measures:

- Reorient or relocate the receiving antenna.
- Increase the separation between the equipment and receiver.
- Connect the equipment into an outlet on a circuit different from that to which the receiver is connected.
- Consult the dealer or an experienced radio/TV technician for help.

Appendix

A.1 Specification TRANSIT

ITEM	SPECIFICATION
Protection class	IP65
Operational temperature	-30°C ... +50°C (-22°F ... +122°F)
Storage temperature	-40°C ... +85°C (-40°F ... +185°F)
Relative humidity	10 ... 93% non-condensing
Identification range	Typical 10 meters (33 ft)
Power supply	24VDC +/- 10%, 500mA
Frequency range	2438.4MHz ... 2457.0MHz
Safety	EN 60950
Complies to the following regulations	FCC Part 15.245

A.2 Specification AW900mT

CHARACTERISTIC	SPECIFICATION / DESCRIPTION
RF transmission rate	1.536 Mb/s
Ethernet throughput	935 Kb/s
Output power	+21 dBm
Receive sensitivity	-97 dBm
Radio channels/bandwidth	12 non-overlapping with 2.0833 MHz spacing and 1.75 MHz occupied bandwidth
Automatic frequency select	Yes, radio channel automatically selected and adaptively optimized
Connector types	RF RPSMA Female / Ethernet RJ45 10BaseT / Power Jack P5-2.1 mm ID
Status LEDs	Power, Ethernet Link, RF RX, RF TX, 4/Channel, and 6/Link Quality
Error correction technique	Sub-block error detection and retransmission
Regulator type	Switching regulator
Power consumption	Transmit: 1.4 W Receive: 0.8 W
Voltage	4.5-48 VDC at screw terminal 9-48 VDC over Ethernet 12-26 VAC at screw terminal
Temperature range	-40° C to 70° C
Transmit current draw	250 mA at 5 VDC 110 mA at 12 VDC 32 mA at 48 VDC
Size	65 x 65 x 33 mm

A.3 Specification EDGEPLUS SOLO ES400

Description	Specification
Power Supply	12-16VDC or Power over Ethernet (PoE)
Maximum current at 12VDC per EdgeReader	1 Amp
Average operating current at 12VDC	300 mA – ERW400 EdgeReader and no accessories
Maximum Supplied Power	
- ERW400 EdgeReader	600 mA – Split between one or two relays
- E400 EdgePlus	700 mA – Split between a reader and one or two relays
Relay Contact Rating	2 Amps @ 30VDC
Operating temperature range	32°-122°F (0°-50°C)
Humidity	5% to 95% non-condensing