

# TRANSIT Entry Installation Guide



**FCC ID: CGD-TRANSITENTRY**

This device complies with part 15 of the FCC rules. Operation is subject to the following two conditions: (1) this device may not cause harmful interference, and (2) this device must accept any interference received, including interference that may cause undesired operation. Changes or modifications not expressly approved by the party responsible for compliance could void the user's authority to operate the equipment.

2007-09-26

Part #: 5268605

This information is furnished for guidance, and with no guarantee as to its accuracy or completeness; its publication conveys no license under any patent or other right, nor does the publisher assume liability for any consequence of its use; specifications and availability of goods mentioned in it are subject to change without notice; it is not to be reproduced in any way, in whole or in part, without the written consent of the publisher.

## CONTENTS

CONTENTS.....	2
1 INTRODUCTION .....	3
1.1 PRODUCT DESCRIPTION .....	3
1.2 OPTIONAL CARD TECHNOLOGY READER INTERFACE .....	3
2 INSTALLATION.....	4
2.1 SAFETY PRECAUTIONS.....	4
2.2 MOUNTING INSTRUCTIONS.....	4
2.3 ADJUSTABLE MOUNTING BRACKET.....	5
2.4 OPENING THE SERVICE COVER .....	6
2.5 INSTALLING AN OPTIONAL INTERFACE BOARD.....	7
2.5.1 AVAILABLE INTERFACE BOARDS .....	7
2.5.2 INSTALLATION PROCEDURE .....	8
3 CONNECTIONS.....	9
3.1 POWER SUPPLY .....	10
3.2 COMMUNICATION .....	11
3.2.1 RS232 CONNECTION .....	11
3.2.2 RS422 CONNECTION .....	12
3.2.3 WIEGAND, MAGSTRIPE, BARCODE CONNECTION .....	13
3.2.4 USB CONNECTION .....	14
3.3 DIGITAL I/O .....	15
3.3.1 RELAY OUTPUT.....	15
3.3.2 READ DISABLE INPUT.....	16
3.3.3 GENERAL PURPOSE INPUTS .....	17
3.3.4 GENERAL PURPOSE OUTPUTS.....	18
3.3.5 TAMPER SWITCH.....	19
4 DIP-SWITCH SETTINGS .....	20
4.1 RANGE BEEPER ON / OFF .....	20
4.2 RS232 / RS422 SELECTION.....	20
4.3 UNUSED SW1-3 AND SW1-4.....	20
5 LED INDICATIONS .....	21
6 FREQUENCY SELECTION .....	22
7 READ RANGE CONTROL (SQUELCH) .....	23
7.1 PRINCIPLE .....	23
7.2 READ RANGE ADJUSTING.....	23
8 IDENTIFICATION .....	24
8.1 STANDARD OPERATING PROCEDURE.....	24
8.2 USING THE MTR MODULE.....	24
9 FIRMWARE UPGRADE .....	25
A TECHNICAL SPECIFICATIONS.....	26
B PART NUMBERS.....	27

## 1 INTRODUCTION

### 1.1 PRODUCT DESCRIPTION

Nedap's handsfree access solution represents the latest in technology for secure handsfree doors access and other RFID applications. TRANSIT Entry combines the convenience of traditional door automation with the security of restricted areas.

It makes a perfect fit to any door or vehicle gate environment where handsfree access is required. The system reads at distances up to 4 meter <sup>(12 feet)</sup> reliable and consistently. This has great appeal to people, especially in situations where it is inconvenient to use their hands when presenting an ID badge when accessing a door, but where high security needs to be maintained.

Moreover it offers handsfree vehicle access to gated areas. Vehicles are identified at a range up to 4 meters <sup>(12 feet)</sup>, without the hassle of having to open the window to present a card.

The handsfree access system is made up of a TRANSIT Entry reader and a transponder. TRANSIT Entry readers are installed next to a door or gate. A long range transponder visible in line of sight of the reader will be identified at distances up to 4 meter <sup>(12 feet)</sup>.

### 1.2 OPTIONAL CARD TECHNOLOGY READER INTERFACE

The TRANSIT Entry reader also features an optional proximity and ISO compliant smartcard interface. This Multi-Technology Reader Module (MTR) enables the reader to read standard proximity cards and smartcard CSN. This also allows the reader to operate with existing credentials when presented to the face of the reader.

The MTR supports the following card technologies:

- 120-125 kHz: HID prox, Nedap and EM read-only.
- 13.56 MHz: HID iClass CSN, MIFARE, LEGIC Advant UID, ISO14443A and ISO15693.

## 2 INSTALLATION

### 2.1 SAFETY PRECAUTIONS

The following safety precautions should be observed during normal use, service and repair.

- The TRANSIT Entry must be connected with safety ground.
- The TRANSIT Entry may only be installed and serviced by qualified service personnel.
- Disconnect the power supply before removing or installing any parts.
- To be sure of safety, do not modify or add anything to the TRANSIT Entry other than mentioned in this installation guide or indicated by NEDAP N.V.

### 2.2 MOUNTING INSTRUCTIONS

The TRANSIT Entry can be mounted to any surface, including directly to metal. Locate an appropriate position. Use the upper two keyholes (K) to mount the reader. Open the service cover to secure the reader using the two lower mounting positions (L).

See the picture below for details about the dimensions and the locations of the mounting positions.

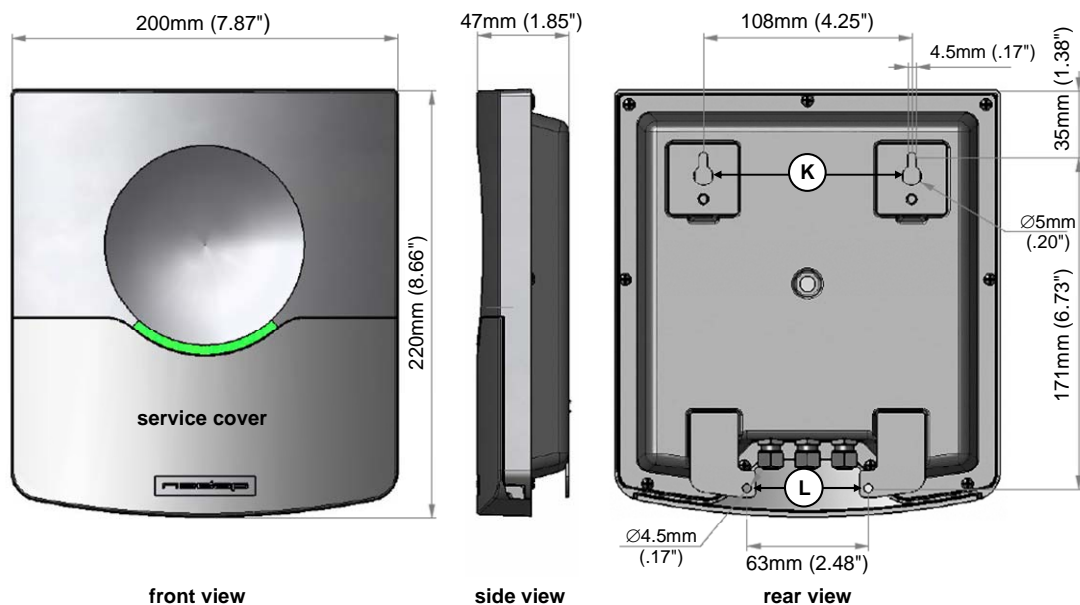

**Figure 1: TRANSIT Entry reader dimensions**

### 2.3 ADJUSTABLE MOUNTING BRACKET

With the adjustable mounting bracket, the TRANSIT Entry can be 'aimed' at the desired detection area. It can also be used for mounting the reader to round or square masts (see appendix B for part numbers).

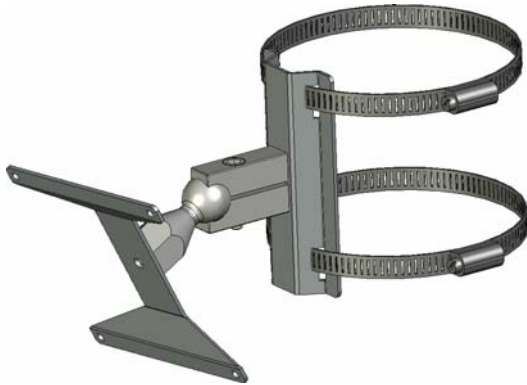

**Figure 2: Adjustable mounting bracket**

Once the adjustable mounting bracket is assembled, attach the bracket to the wall or mast. After that the TRANSIT Entry can be mounted onto the bracket. The ball and socket joint can be used to adjust the reader's orientation. Tighten the hex screw on top of the joint to fix the correct orientation.

*Note: Maximum diameter for round masts 125mm (4.9 inch)  
Maximum diameter for square masts 100mm (3.9 inch)*

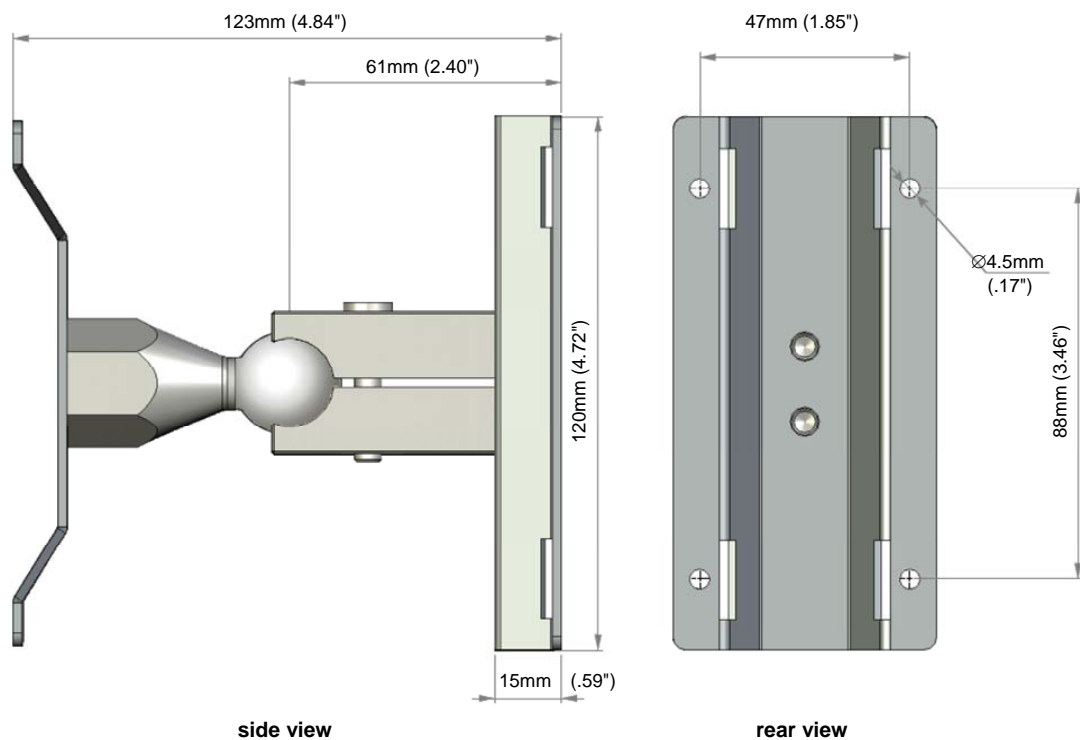
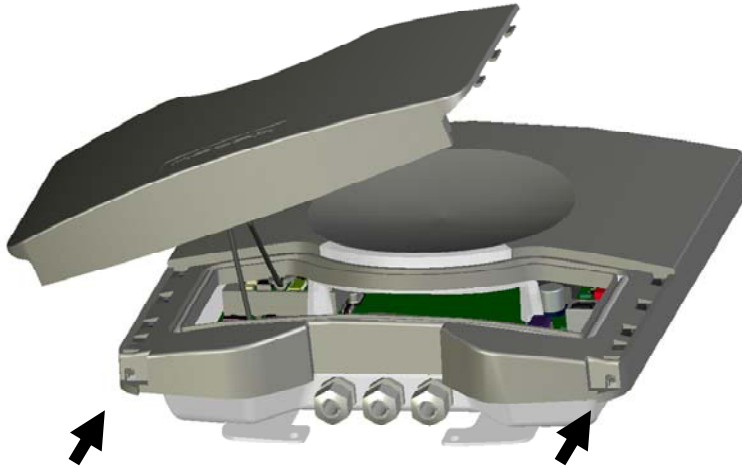

**Figure 3: Adjustable mounting bracket dimensions (in mm)**

## 2.4 OPENING THE SERVICE COVER

The service cover can be opened to access the connections, control the read range, setup the operating frequency and view the LED indicators.

Open the screws on the bottom of the device to unlock the service cover. Once the service cover is unlocked, lift it off.



**Figure 4: Opening the service cover**

---

*Note: Make sure the screws are completely opened (and closed when placing the cover back on). Don't worry about losing the screws, they cannot fall out.*

---

## 2.5 INSTALLING AN OPTIONAL INTERFACE BOARD

Make sure to follow all safety precautions outlined in chapter 2.1 and disconnect the power supply when installing or replacing an optional interface board.

### 2.5.1 AVAILABLE INTERFACE BOARDS

Various optional interface boards are also available for the TRANSIT Entry.

Ethernet (TCP/IP) interface board



Connects the TRANSIT Entry to an Ethernet network using the TCP/IP protocol.  
See for detailed information about the Ethernet communication board its user's manual.

MTR Module (Multi Technology Reader Module)

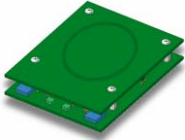

The MTR Module enables proximity reading of many transponders types such as HID Prox, EM read-only, Mifare and HID iCLASS.

HIB (HID Interface Board)



Enables the reading of HID prox cards with an HID Prox Booster.

See appendix B for part numbers.

## 2.5.2 INSTALLATION PROCEDURE

1. Disconnect the power supply.
2. Remove the complete front cover from the TRANSIT Entry.
3. Place the interface board on the 14-pin header K1. Make sure it's firmly positioned and makes good contact with connector K1.

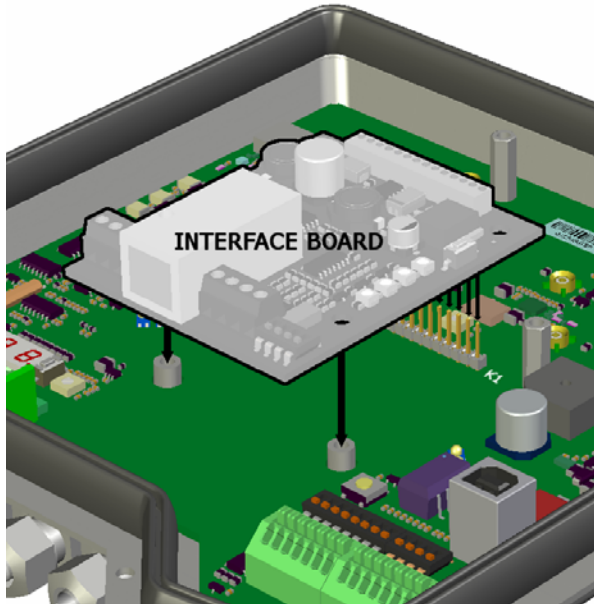

**Figure 5: interface board installation**

4. Tighten the two screws to fix the board into place.
5. Read the board's installation guide for additional notes like address settings, jumper settings and wiring details.
6. Replace the front cover on the TRANSIT Entry.



### 3 CONNECTIONS

Wire connections to the TRANSIT Entry are user friendly spring cage terminal connectors.

Connection procedure with spring cage terminal connectors.

1. Strip wire lead for about 9 mm (0.35 inch).
2. Push the screwdriver straight down to release the spring cage. Use a slotted, narrow-head screwdriver.
3. Insert the wire lead into the wire terminal.
4. Remove the screwdriver, this clamps the wire.
5. Gently pull on the installed wire to make sure the connection is reliable.

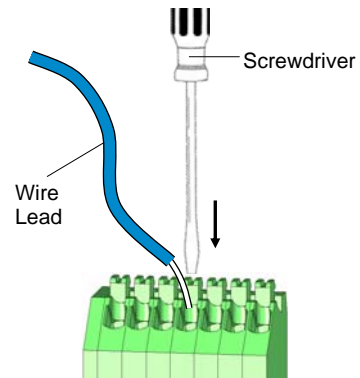

**Figure 6: Wiring detail**

---

*Note 1: Each connector terminal can accommodate only 1 solid or stranded wire.*

*Note 2: Wiring is normally done without ferrules. However, it is possible to use ferrules, provided that they are properly crimped.*

---

See appendix A for recommended maximum and minimum conductor cross sections and for the recommended wire stripping length.

### 3.1 POWER SUPPLY

The TRANSIT Entry requires DC power supply in the range from 12 – 24V. Maximum current consumption is 1A @ 12VDC, 0.5A @ 24VDC.

Connections:

- |      |  |
|------|--|
| DC - | Power supply 0V. Should be connected to a protective earth connection. |
| DC + | Power supply 12 - 24VDC.   |

---

*Note: The power supply connection has an auto resetting fuse protection.*

---

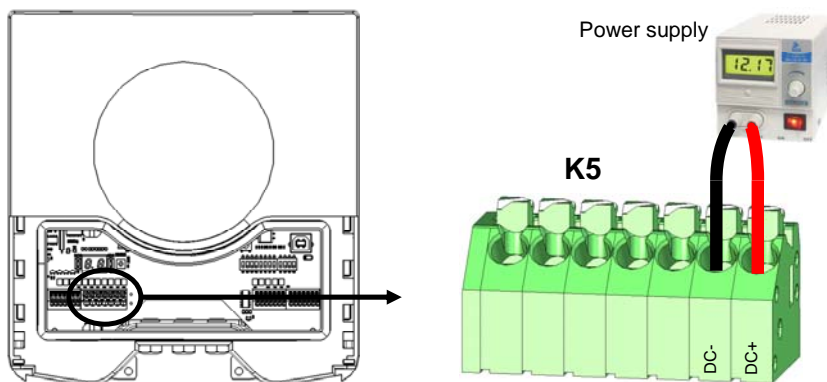

**Figure 7: Power supply wiring**

## 3.2 COMMUNICATION

### 3.2.1 RS232 CONNECTION

The TRANSIT Entry has an on-board RS232 interface. This interface does not support any hardware handshake signals. The communication protocol, baud rate, data format and flow control depend upon the reader firmware. See firmware manual for details.

Connections:

RXD	Receive data (input)
GND	Ground
TXD	Transmit data (output)

*Note 1: Maximum cable length of 15 meters (50 feet) or the cable length equal to a capacitance of 2500pF.*

*Note 2: Enable the on-board RS232 interface by setting DIP-switch SW1-2 to ON. See chapter 4.2 for details.*

*Note 3: The RS232 interface is disabled while the USB interface is in use !!!*

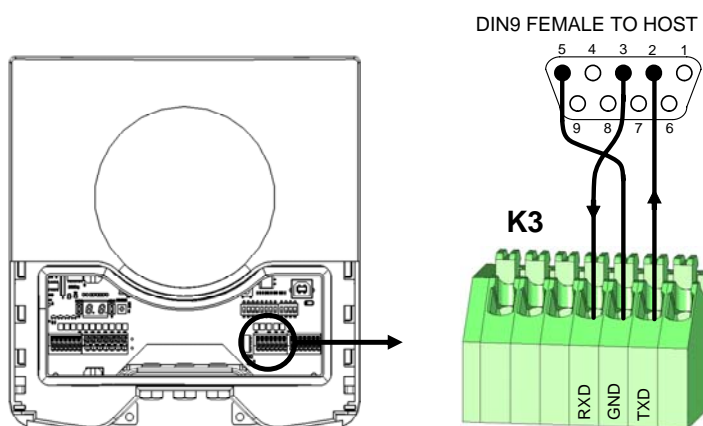

**Figure 8: RS232 wiring**

### 3.2.2 RS422 CONNECTION

The TRANSIT Entry has an on-board RS422 interface. The communication protocol, baud rate, data format and flow control depend upon the reader firmware. See firmware manual for details.

The RS422 interface is similar to the RS232 interface. The RS422 interface is commonly used where longer cable lengths are required.

Connections:

RX+	Receive line (positive)
RX-	Receive line (negative)
GND	Ground
TX+	Transmission line (positive)
TX-	Transmission line (negative)

RX+ and RX- inputs are terminated with a 120Ω resistor.  
TX+ and TX- must be terminated at the host side.

*Note 1: Maximum cable length 1200 meters (4000 feet).*

*Note 2: Enable the on-board RS422 interface by setting DIP-switch SW1-2 to OFF. See chapter 4.2 for details.*

*Note 3: The RS422 interface is disabled while the USB interface is in use !!!*

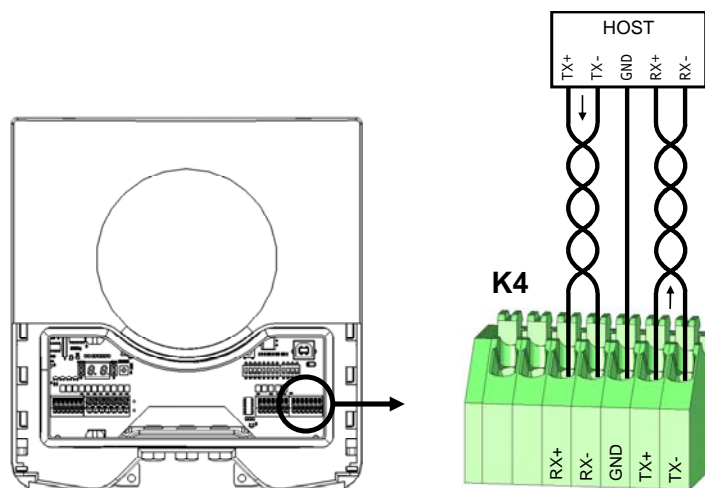

**Figure 9: RS422 wiring**

### 3.2.3 WIEGAND, MAGSTRIPE, BARCODE CONNECTION

The synchronous communication interface wiring depends upon the selected communication protocol and the reader firmware. Please refer to the firmware manual for more details.

In Figure 10 the wiring for the Wiegand protocol is outlined.

Connections:

	<b>WIEGAND</b>	<b>MAGSTRIPE</b>	<b>BARCODE</b>
<b>OUT1</b>	-	Card Loaded	-
<b>OUT2</b>	Data-0 (green)	Clock	-
<b>OUT3</b>	Data-1 (white)	Data	Data
<b>GND</b>	Ground (black)	Ground	Ground

*Note: Maximum cable length 150 meters (500 feet)*

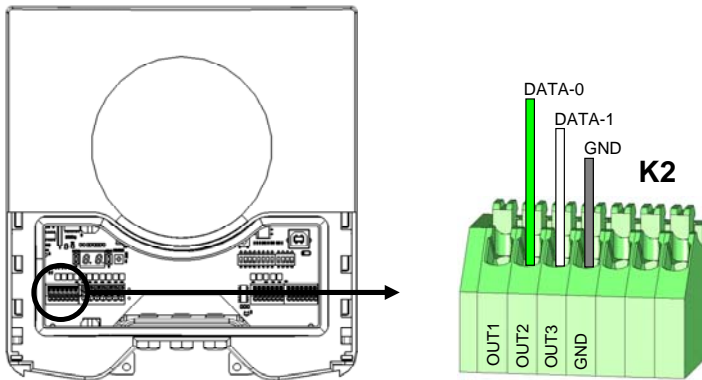

**Figure 10: Wiegand wiring**

### 3.2.4 USB CONNECTION

The TRANSIT Entry features an USB interface for service and installation purposes. The USB connector (Type B) is accessible behind the service cover.

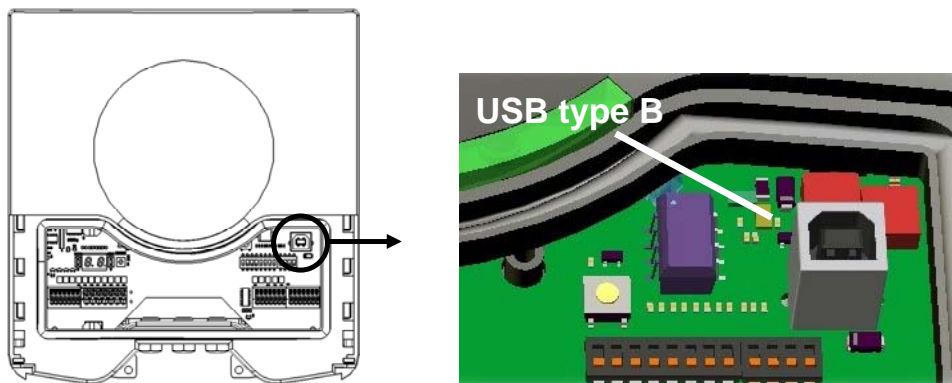

**Figure 11: USB interface**

---

*Note: While the USB interface is in use, the on-board RS232 and RS422 interfaces are disabled. Also when an optional interface board is placed (e.g. TCP/IP) the board will be disabled as long as the USB interface is in use.*

---

#### USB Driver installation

Make sure your computer is connected to the internet. The driver should install automatically via Windows update when the TRANSIT Entry is connected to your PC via the USB cable. Follow the driver installation wizard. If you do not see the Windows update pop-up, you can manually install the driver. To manually install, you need to go to FTDI's website at [www.ftdichip.com/Drivers/VCP.htm](http://www.ftdichip.com/Drivers/VCP.htm) and download the VCP (Virtual Com Port) drivers for your operating system. Drivers for MacOS and Linux are available as well.

### 3.3 DIGITAL I/O

#### 3.3.1 RELAY OUTPUT

The relay output is automatically activated upon identification of a transponder. This behavior can be changed and configured by means of the firmware. Please refer to the firmware manual for more details.



The 'smile' on the front cover lights-up simultaneously with the relay output.

Connections:

NC	Relay contact normally closed
COM	Relay contact common
NO	Relay contact normally open

Contact ratings:

Max. switching current:	2A
Max. switching voltage:	250VAC / 220VDC
Max. switching power:	62.5VA / 60W

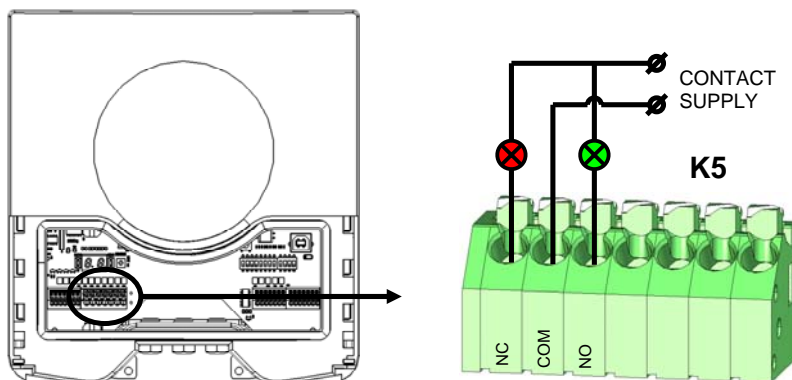

**Figure 12: Relay output**

### 3.3.2 READ DISABLE INPUT

The reading of the TRANSIT Entry can be completely disabled with the RDIS input. This input is commonly used in combination with a sensor (e.g. inductive loop) that detects the presence of a person or vehicle. Use always a relay contact to connect the internal 5V to the RDIS input. When the RDIS input is unused the reader is enabled.

Connections:

RDIS	Read disable input
5V	Internal 5V source for read disable input

---

*Warning:* Using an external 5V supply can damage the unit.

---

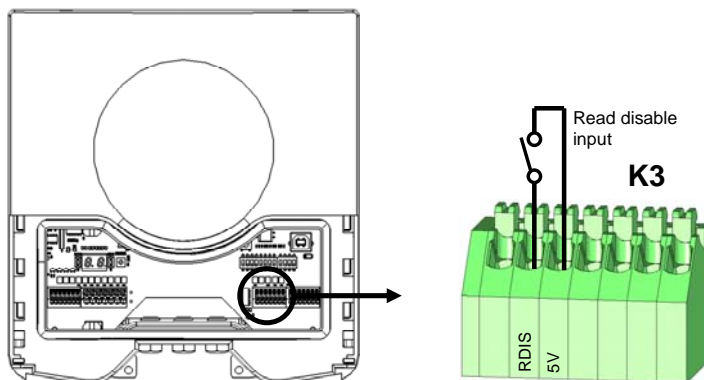

**Figure 13: Read disable input**



### 3.3.3 GENERAL PURPOSE INPUTS

Three general purpose inputs are available on the TRANSIT Entry reader. The inputs are active low.

Connections:

IN1	General purpose input 1
IN2	General purpose input 2
IN3	General purpose input 3
GND	Ground

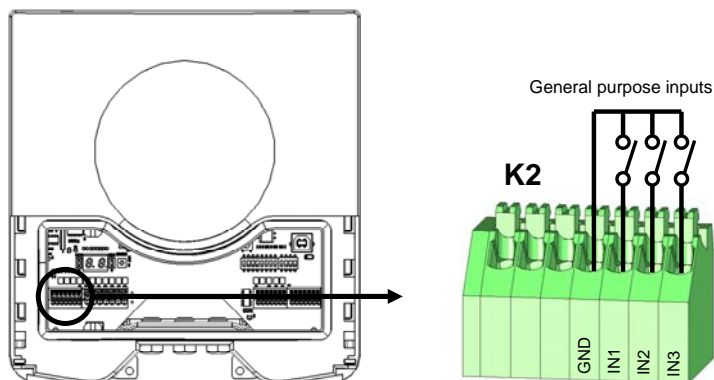

**Figure 14: GPIO inputs**

### 3.3.4 GENERAL PURPOSE OUTPUTS

Three general purpose inputs are available on the TRANSIT Entry reader. The installed firmware may use these outputs for synchronous communication interfaces such as Wiegand, Barcode and Magstripe. See chapter 3.2.3 for more details.

Connections:

OUT1	General purpose output 1
OUT2	General purpose output 2
OUT3	General purpose output 3
GND	Ground

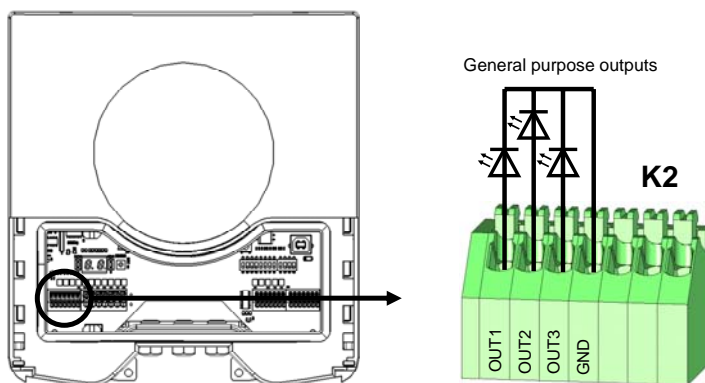

**Figure 15: GPIO inputs**

### 3.3.5 TAMPER SWITCH

An internal magnet provides tamper indication when the service cover is opened. This contact may be connected to an external alarm system. The contacts are normally closed when the cover is in place.

Tamper switches of multiple TRANSIT Entry reader may be connected in series.

Connections:

NC	Tamper switch (normally closed)
COM	Tamper switch (common)

Contact ratings:

Max. switching current	0.5A
Max. switching voltage	200VDC
Max. switching power	10W

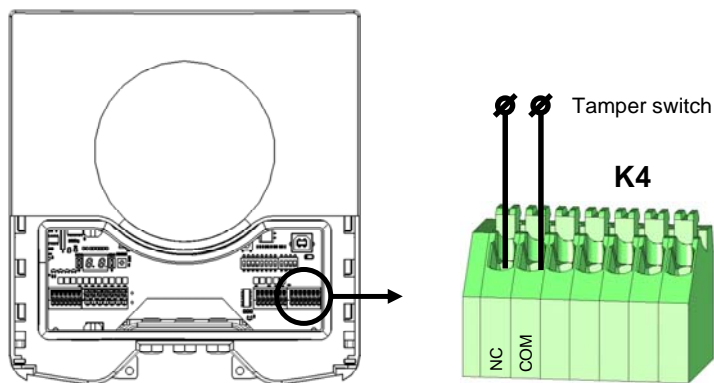
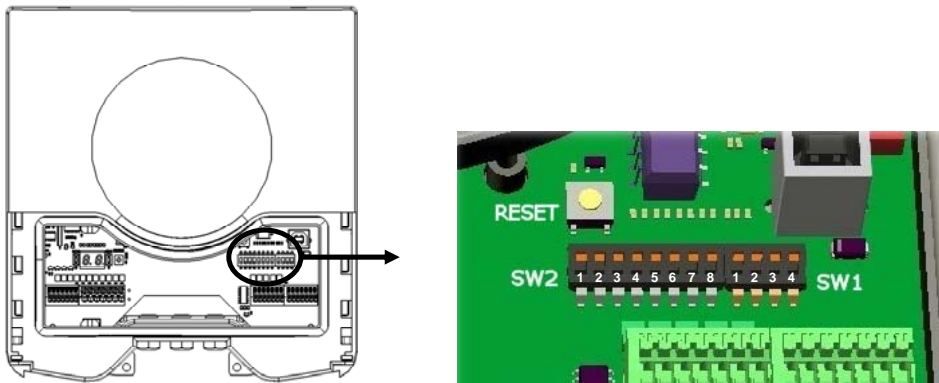

**Figure 16: Tamper switch**

## 4 DIP-SWITCH SETTINGS

The DIP-switches are located behind the service cover. The function of the switches SW2-1 through SW2-8 is dependant upon the installed firmware. Please refer to the firmware manual for details.

The switches SW1-1 through SW1-4 are described below.



**Figure 17: DIP-switches**

### 4.1 RANGE BEEPER ON / OFF

Enable or disable the internal range beeper. The beeper indicates transponder identification. The signal strength of the identified transponder determines the beeping frequency. When the transponder is near to the reader the range beeper will beep fast.

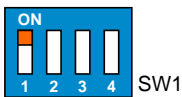

Range beeper ON

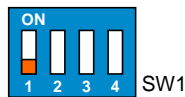

Range beeper OFF

### 4.2 RS232 / RS422 SELECTION

On-board RS232 or RS422 interface selection.



On-board RS232 interface enabled.



On-board RS422 interface enabled.

*Note: The on-board RS232 and RS422 interfaces are both disabled when the USB connector is in use or when the TCP/IP interface board is installed.*

### 4.3 UNUSED SW1-3 AND SW1-4

The switches SW1-3 and SW1-4 are reserved for future use. It is recommended to leave these switches in the ON position.

## 5 LED INDICATIONS

A number of LED's indicate the current status of the TRANSIT Entry reader.



**Figure 18: LED locations**

Table 1 below describes the function of each LED.

LED	Description
	LED bar indicating the received tag signal strength. This LED bar may also indicate the presence of radio interference. In case of interference, try switching to a different frequency. See chapter 6.
	RX LEVEL
	RDIS Read Disable LED. On while reading disabled. See chapter 3.3.2.
	IN1 Input 1 status. On when input 1 contact is closed. See chapter 3.3.3.
	TXD Transmit serial data (RS232, RS422, USB, I/F-board).
	RXD Receive serial data (RS232, RS422, USB, I/F-board).
	ID Identification. Blinks fast when a valid transponder is identified.
	STS Status LED. Slow blinking: System's heartbeat (0.8 sec on / 0.8 sec off). Indicates that the power is on and the processor is running. Fast blinking: Bootloader says hello. Indicated after a restart. Twice blinking: Configuration menu active. Off: Abnormal situation.
	SQ-ENA Squelch enabled. See chapter 7.
	SQ-ACT Squelch active. See chapter 7.
	DC-HI Power supply voltage too high. See chapter 3.1.
	DC-LO Power supply voltage too low. See chapter 3.1.
	DC-FAIL Internal supply voltage failure. See chapter 3.1.
	T-CRIT Temperature critically high.
	PLL UL PLL unlocked. Try switching to a different frequency. See chapter 6.

**Table 1: LED indicators**

## 6 FREQUENCY SELECTION

The TRANSIT Entry reader operates in the 2.45GHz frequency band. When two or more readers are within a range of 15 meters (50 feet), these readers should be set on a different operating frequency. The selected frequency has to comply with local radio regulations.

Press the UP or DOWN switch once and the display will show a value indicating the currently selected frequency. Lookup the display value in the table below to find out what the actual operating frequency is.

When the display is on, press the UP switch to select a higher frequency. Similarly, press the DOWN switch to select a lower frequency.

The display will automatically switch off after 5 seconds.

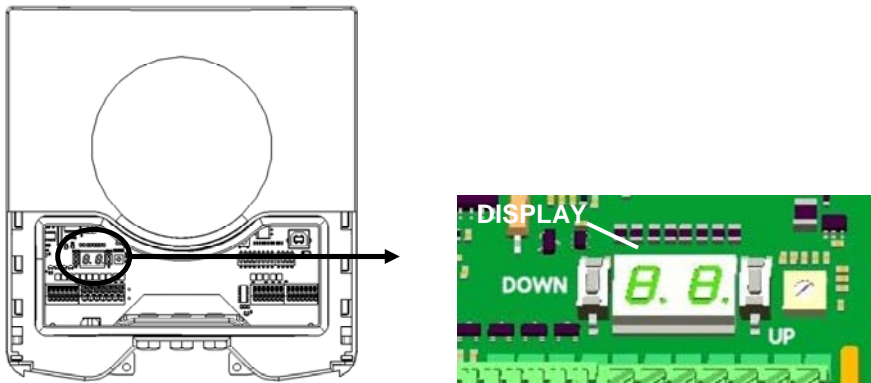

**Figure 19: frequency setting**

Display value	Frequency (GHz)	Wifi
50	2.4384	
51	2.4390	
52	2.4396	
53	2.4402	
54	2.4408	
55	2.4414	
56	2.4420	CH7
57	2.4426	
58	2.4432	
59	2.4438	
5A	2.4444	
5B	2.4450	
5C	2.4456	
5D	2.4462	
5E	2.4468	
5F	2.4474	CH8
60	2.4480	
61	2.4486	
62	2.4492	
63	2.4498	
64	2.4504	
65	2.4510	
66	2.4516	
67	2.4522	CH9
68	2.4528	
69	2.4534	
6A	2.4540	
6B	2.4546	
6C	2.4652	
6D	2.4558	
6E	2.4564	
6F	2.4570	CH10

**Table 2: Frequency values**

## 7 READ RANGE CONTROL (SQUELCH)

### 7.1 PRINCIPLE

The read range of the TRANSIT Entry can be controlled with the embedded squelch function. The squelch references the received signal strength against the squelch level setting. When the received signal strength is below the squelch level no identification is possible. The received signal strength becomes higher when the transponder approaches the reader. When the received signal strength exceeds the squelch level the transponder will be identified.

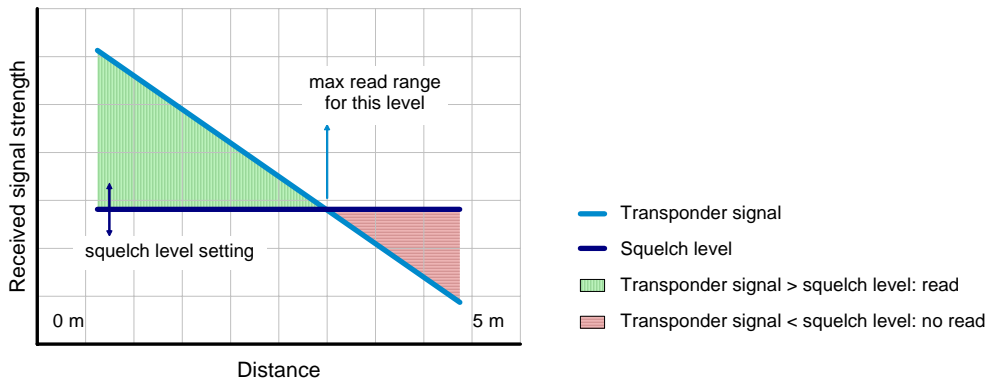

**Figure 20: Squelch principle**

### 7.2 READ RANGE ADJUSTING

- ↻ SQ-LVL potentiometer completely clockwise: Maximum read range (squelch disabled).
- ↻ SQ-LVL potentiometer completely counter-clockwise: Minimum read range.

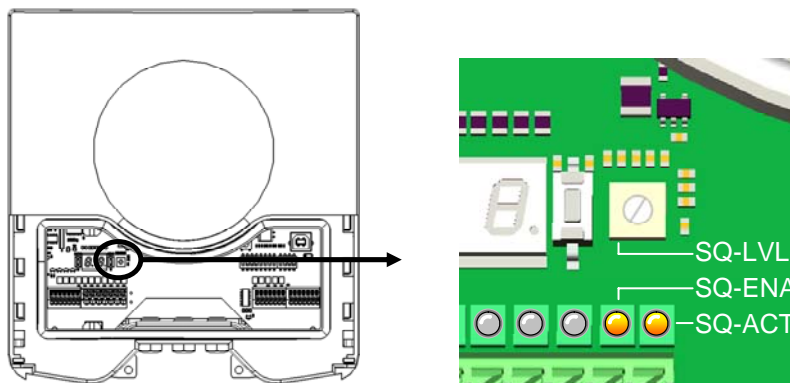

**Figure 21: Squelch level setting**

Two LEDs indicate the status of the squelch. When the squelch is enabled (potentiometer SQ-LVL not completely clockwise) LED SQ-ENA will be on. LED SQ-ACT is on when the transponder signal is below the squelch level (red area in Figure 20). In chapter 5 all LED indicators are described.

## 8 IDENTIFICATION

The TRANSIT Entry reader is always reading (except when disabled with the read disable input, see chapter 3.3.2). Automatically upon identification of a transponder the relay will be activated, the 'smile' lights-up and an event message is generated on the communication interface(s).

### 8.1 STANDARD OPERATING PROCEDURE



The TRANSIT Entry was designed to implement secure handsfree access. The system reads at distances up to 4 meters (12 feet). This has great appeal, especially in situations where people cannot use their hands to present their ID badge. Moreover it offers handsfree vehicle access to gated areas. Vehicles are identified at range, without having to open the window to present a card. Only line-of-sight between transponder and reader is required.

On-site adjustable read-range in case of cross over reading (see chapter 7). On-site adjustment of the frequency channel to avoid radio interference (see chapter 6).

### 8.2 USING THE MTR MODULE



The TRANSIT Entry reader can be featured with an optional proximity and ISO compliant smartcard interface, called Multi-Technology Reader Module (MTR). This MTR interface will enable the reader to read standard proximity cards and smartcard CSN, allowing it to operate with existing credentials at short range, when presented to the face of the reader. See chapter 2.4 for more information about installing the MTR board.

The MTR eliminates the need for multiple readers mounted next to a door or gate. Please refer to the MTR manual for more details. The following card types are supported with the MTR:

- 120-125 kHz: HID prox, Nedap and EM read-only.
- 13.56 MHz: HID iClass CSN, MIFARE, ISO14443A and ISO15693.

Proximity cards must be presented to the circle on the front cover of the TRANSIT Entry reader. The MTR reads from all supported transponder types their card serial number. For Mifare Classic and Ultralight cards optionally the MTR can be configured to read data from a (secured) sector. Configuration is done with a configuration card, which can be programmed with the 'Smartcard-Booster Config' software. This software can be downloaded from our website [www.nedapavi.com](http://www.nedapavi.com).

---

*Note: It is not possible to install the MTR module together with an additional interface board, such as the TCP/IP interface board.*

---



## 9 FIRMWARE UPGRADE

The firmware in the TRANSIT Entry's processor can be upgraded by means of the serial interface (RS232, RS422 or USB). The upgrade is performed by the 'PIC downloader' application. The upgrade procedure is described below.

1. Start the 'PIC downloader' application.
2. Select the serial port to which the reader is connected.
3. Select the firmware file (\*.hex, \*.ehx).
4. Disable 'download customer codes' to prevent your customer codes inside the reader to be overwritten. Enable 'download customer codes' when you want to load the customer codes from the hex-file into the reader. Hex-files on [www.nedapavi.com](http://www.nedapavi.com) contain DEMO customer codes.
5. Click 'Download' to start downloading the firmware.
6. Once the downloading has completed 'PIC downloader' displays the message 'Download successfully completed' and the reader starts the upgraded firmware.

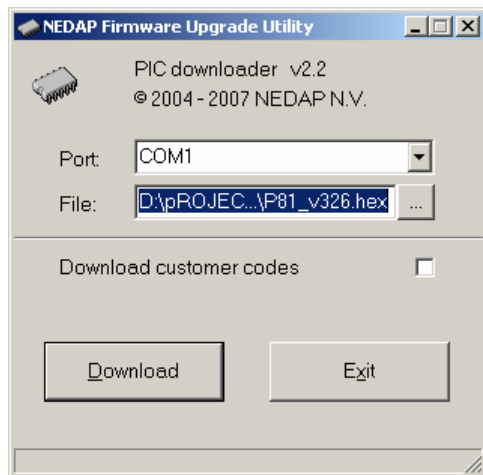
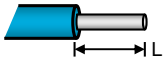

**Figure 22: PIC downloader**

*Note1: Aborted downloads may cause the reader to stop functioning. In such cases repeat the upgrade procedure until it succeeds.*

*Note2: If the message 'Searching for bootloader' does not disappear check the cables and the com-port settings. Sometimes it may be required to restart the reader before the bootloader can be found. Before restarting the reader make sure that the message 'Searching for bootloader' is still shown in the statusbar. The restart is easily performed by pressing the reset-switch.*

## A TECHNICAL SPECIFICATIONS

ITEM	SPECIFICATION	REMARK
Dimensions	200x220x46.5mm (7.87 x 8.66 x 1.83 inch)	
Weight	0.75 kg (1.65 lbs)	
Enclosure color	RAL7017 (darkgray)	
Enclosure material	Polycarbonate	
Chassis material	Aluminum	
Cable entry fittings	M10 x 1.5 IP67	4-6mm cable diameter
Recommended wire stripping length	8 ... 10mm (0.3 ... 0.4 inch)	
Connector K5	0.5mm <sup>2</sup> ... 1.5mm <sup>2</sup> (AWG20 ... 16)	Springcage type PTSA 1.5
Connector K2,3,4	0.14mm <sup>2</sup> ... 0.5mm <sup>2</sup> (AWG24 ... 20)	Springcage type PTSA 0.5
Protection class	IP65	
Operational temperature	-30°C ... +60°C (-22°F ... +140°F)	
Relative humidity	10 ... 93% non-condensing	
Identification range	Typical 4 meters (12 feet)	Line-of-sight required
Power supply	12VDC ... 24VDC	
Current consumption	1A @ 12VDC, 0.5A @ 24VDC	
Operating frequency	2.4384GHz ... 2.4570GHz	
Polarisation	Circular	
EIRP	18.7 dBm linear	
Immunity	EN301 489-3	
Safety	EN60 950	
Emission	EN300 440-2 FCC part 15.245	
Shock	50 G, 6 ms, 10x3 dir	IEC68-2-27 Ea
Bump	25 G, 6 ms, 1000x3 dir	IEC68-2-29 Eb
Random vibration	5 – 150Hz, 5 G, 20 sweeps x 3 dir	EN50155

## B PART NUMBERS

### READERS



TRANSIT Entry

part number: 9876200

### ACCESSORIES



Ethernet (TCP/IP) board

part number: 7817940

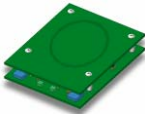

MTR Module

part number: 7816650



HID interface board

part number: 7819102



Adjustable mounting bracket

part number: 9875840

### TRANSPONDERS



Compact Tag

part number: 9891900



Window Button  
Window Button Switch

part number: 9882650

part number: 9882480

For full product information visit [www.nedapavi.com](http://www.nedapavi.com)