Neo_M660

User Manual

Version V1.0

有尔科技 NEOWAY

Shenzhen Neoway Technology Co.,Ltd

Copyright Statement

Copyright © 2008 Neoway Technology

All rights reserved by Shenzhen Neoway Technology Co.,Ltd.



The trademark  belongs to Shenzhen Neoway Technology Co.,Ltd. Other trademarks in this manual belongs to their owners.

Clarification

This specification is for system engineer, research engineer and test engineer.

As the upgrading of the product version or some other reasons, we'll do some necessity updating to the content of this specification without advance notice.

Unless we have other additional assumpsit, all statements, information and suggestions in this manual do not constitute any express or implied guarantees.

Shenzhen Neoway Technology Co.,Ltd can supply all the technological support. If you have any problem, please feel free to contact to the sales representative or send E-mail to these two mailboxes:

Sales@neoway.com.cn

Support@neoway.com.cn

Website: www.neoway.com.cn

Contents

1	Overview	5
2	Figuration	5
3	Block Diagram	5
4	Character	6
5	Pin Definition & Encapsulation	8
5.1	Pin Definition	8
5.2	PCB Packaging	9
6	General AT Commends	10
7	Call Control Commends	11
8	TCP/UDP AT Commends	11
9	Assembling	11

Revision Record		
Version	Content Revised	Effective date
V1.0	Initial version	2012-06

1 Overview

M660 is an open platform that supports GSM/GPRS wireless industry module, reserved CPU resources and a wealth of hardware interface which is widely used in various industrial and commercial fields to provide high quality voice, message, data business and other functions.

2 Figuration

Table 2-1 M660 Figuration Specification

Specifications	Description
Dimensions	23.6mm*23.6mm*2.6mm (length*width*height)
Weight	2.8g
Overview	

3 Block Diagram

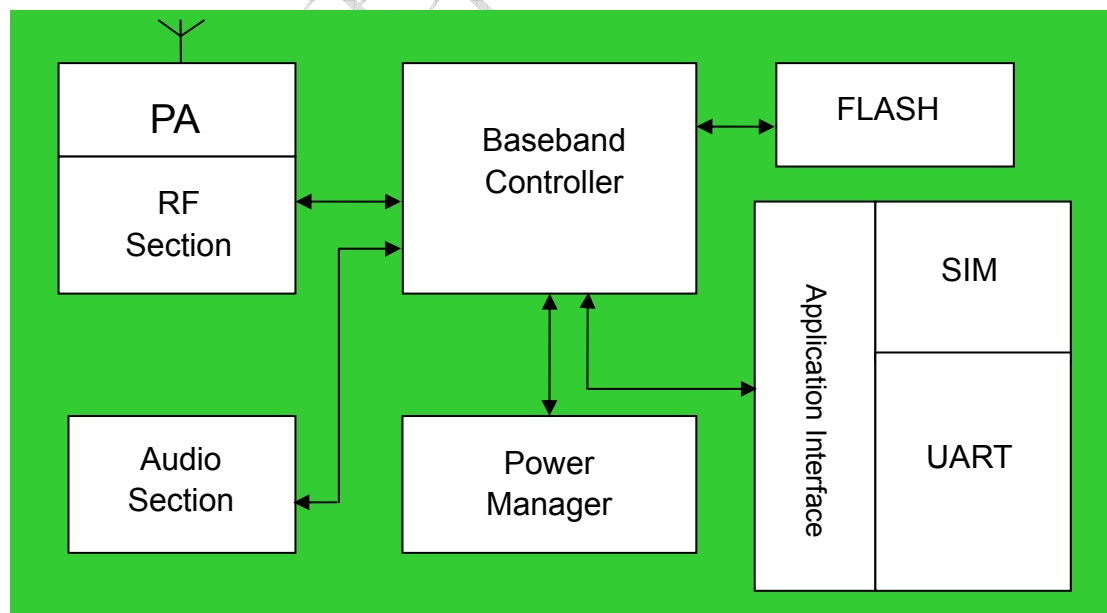

4 Character

Table 4-1

General parameters	Description
Operating temperature	-30 ~ +70
Operating voltage	3.5V ~ 4.3V (recommendation 3.9V)
Operating Current	See table 4-2 and 4-3
Storage temperature	-40 ~ +80
Humidity range	0% ~ 95%

Table 4-2

GSM Specifications	Description
Frequency	900/1800/850/1900
Sensitivity	< -106dBm
The Maximum transmission Power	850/900 Class4(2W) 1800/1900 Class1(1W)
Protocol	Compatible with GSM/GPRS Phase2/2+
AT	GSM07.07 Extended command sets
Audio	FR、EFR、HR、AMR voice coding
SMS	TEXT/PDU Point to point/cell broadcast
Grouped Data	GPRS CLASS 12
Coding scheme	CS1~CS4
Mobile Station type	Class B
Circuit Switched Data	Support CSD data service Support USSD
Supplement Service	Call forward (CFB,CFNA,CFU) Call waiting Threeway calling
Main Processor	ARM7-EJ@104MHz, 32Mbits SRAM,32~64Mbits Nor Flash
Reserved software	16Mbits RAM , 16~32Mbits Flash

resource	
Reserved software resource	UART x 2 , I2C , LCD (SPI) , MMC , USB , ADC , PWM , GPIO x 20 , Keypad
Instantaneous Current	Max 1.8A
Average working Current	< 300mA
Standby Current	2.5mA typ.

5 Pin Definition & Encapsulation

5.1 Pin Definition

The signal connection uses 28pin SMD pad of stamp hole(half hole).

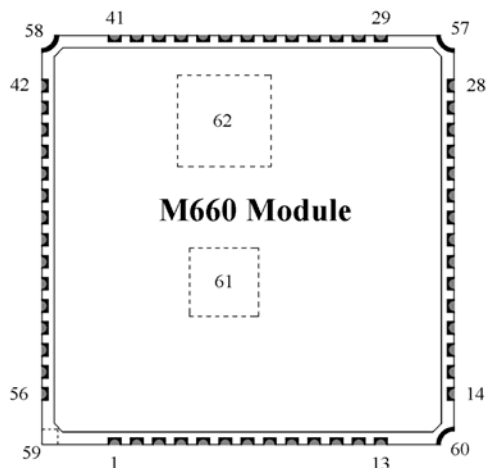

Note: M660 module IO interface level is 2.8V.

Because the module IO uses 2.8V power supply system, the maximum input voltage of all the IO interface can not exceed the maximum 3.3V, otherwise it may damage the module IO. Considering the signal integrity designing reasons, while the external circuit use 3.3V power system the IO interface output voltage will exceed 3.3V because of overshoot phenomenon, sometimes can even reach 3.5V. Therefore, the IO pin of the module will be damaged if 3.3V signal is connected to 2.8V IO of the module directly.

Table 5-1 M660 Pin Definition

Pin	Signal Name	I/O	Function Description	Remark
1	VSIM	PWR	Main Power	Compatible to 1.8/3.0V SIM card
2	SIM_CLK	DO	Clock of SIM card	
3	SIM_DATA	DIO	Data input & output of SIM card	Built-in 5K pull-up resistor
4	GND	PWR	GRAND	
5	SIM_RST	DO	SIM card reset	
6	MICP	AI	Positive electrode of MIC audio input	Alternating peak voltage≤200mV
7	MICN	AI	Negative electrode of MIC audio input	Alternating peak voltage≤200mV
8	EARP	AO	Positive electrode of	32Ω earphone driving output

			earphone audio output	
9	EARN	AO	Negative electrode of earphone audio output	32Ω earphone driving output
10	DTR	DO	Low power consumption set	
11	GND	PWR	Grand	
12	RING	DI	Ring output	
13	VCCIO	PWR	2.8V output	Can be supplied to IO level shift circuit, loading capacity < 50mA
14	Reserved		Reserved	
15	Reserved		Reserved	
16	URXD	DI	UART data receiving	Used to GPRS communications and AT commands
17	UTXD	DO	UART data transmitting	
18	GND	PWR	Grand	
19	Reset	DI	Reset	Soft reset input, low level reset
20	BACK_LIGHT	DO	Working station indicator, output square signal of 0.5s high level, 1.5s low level	High level light LED , need to parallel connect a capacitor of 0.1uF
21	ON/OFF	DI	ON/OFF input	low level pulse can change ON/OFF state, need to keep high level , Refer to chapter 6.1.3
22	ANT	I/O	GPS antenna RF interface	
23	GND	PWR	Grand	
24	GND	PWR	Grand	
25	GND	PWR	Grand	
26	VBAT	PWR	Main Power	3.5V~4.3V , recommend 3.9V
27	VBAT	PWR	Main Power	3.5V~4.3V , recommend 3.9V
28	GND	PWR	Grand	

5.2 PCB Packaging

The signal connection use 74pin SMD pad.The pin is stamp hole(half hole).The pitch is 1.27mm.The PCB encapsulation we recommend is as chart 5-1.Unit:mm

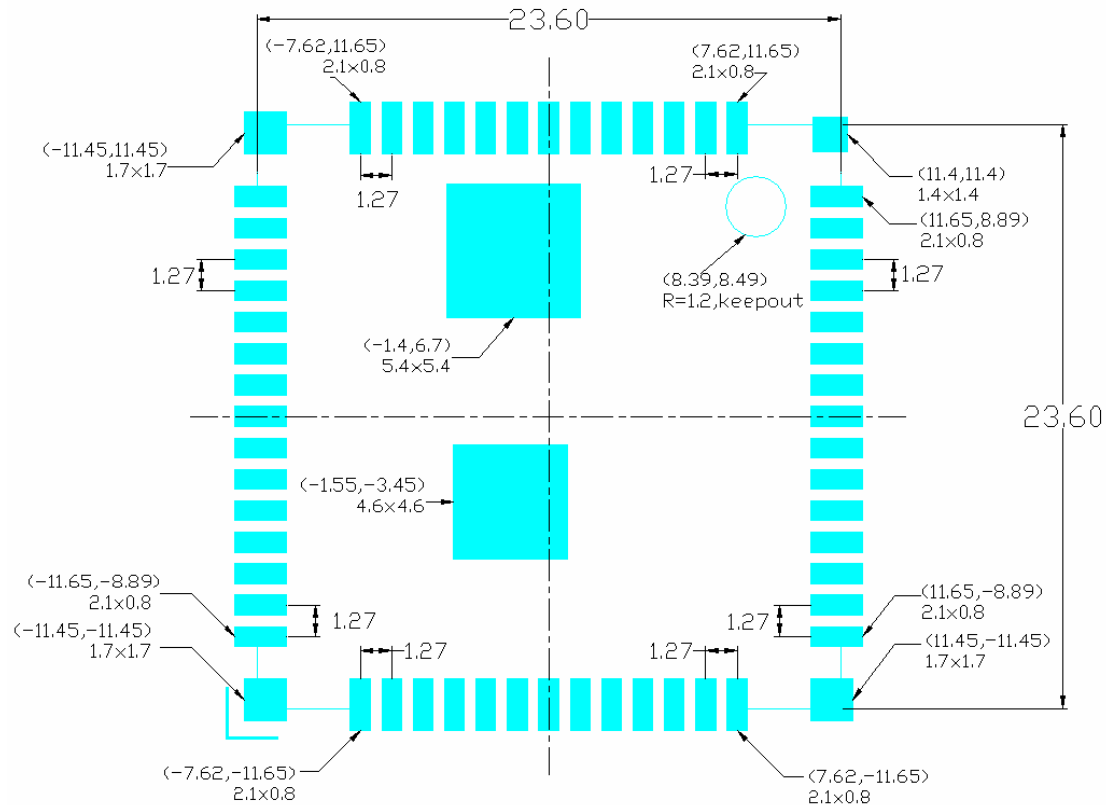

Chart 5-1 Recommend PCB packaging (topview)

Note :The number in the brackets stand for coordinate figure of the pad.The original point is the center of the module.

The number below the coordinate figure stand for shape size of the pad's LxW.

The top right corner and the bottom right corner is two circle regions(R=1.3).The circle regions are route keep out regions.The requirements of the wiring refer to chapter 6.6. Reliability and Testing standards

6 General AT Commands

CHECK THE MANUFACTURE	AT+CGMI
QUERY MODULE MODEL	AT+CGMM
QUERY VERSION	AT+GETVERS
GET SEQUENCE NUMBER	AT+CGSN
GET INTERNATIONAL MOBILE SUBSCRIBER IDENTIFICATION	AT+CIMI
GET SIM CARD IDENTIFICATION	AT+CCID

7 Call Control Commends

CALL ANSWERING	ATA
DIALING COMMENDS	ATD
HAND UP CALLS	ATH

8 TCP/UDP AT Commends

ESTABLISH PPP LINK	AT+XIIC
ESTABLISH TCP LINK	AT+TCPSETUP
SEND TCP DATA	AT+TCPSEND
CLOSE TCP LINK	AT+TCPCLOSE
ESTABLISH UDP LINK	AT+UDPSETUP
SEND UDP DATA	AT+UDPSEND
CLOSE UDP LINK	AT+UDPCLOSE

9 Assembling

In order to prevent the product of M660 from being affected with damp, caused by using the SMT way to perform the furnace welding, in the process of production and use of the costumer, we employ the way of damp-proof packing, such as Aluminum Foil Bag, desiccating agent, Humidity Indicator Cards, Suck plastic trays, and vacuolization. As a result the product is kept dry and its life span will be long.

In order to make the SMT way easy, we use the tray to load the product. The user only needs to install it in the chip machine according to the fixed direction.

M660 storage and SMT notes, please refer to <Neoway module SMT reflow production recommendation_V1.0>.

FCC Caution

Any Changes or modifications not expressly approved by the party responsible for compliance could void the user's authority to operate the equipment.

This device complies with part 15 of the FCC Rules. Operation is subject to the following two conditions: (1) This device may not cause harmful interference, and (2) this device must accept any interference received, including interference that may cause undesired operation.

Note: This equipment has been tested and found to comply with the limits for a Class B digital device, pursuant to part 15 of the FCC Rules. These limits are designed to provide reasonable protection against harmful interference in a residential installation. This equipment generates uses and can radiate radio frequency energy and, if not installed and used in accordance with the instructions, may cause harmful interference to radio communications. However, there is no guarantee that interference will not occur in a particular installation. If this equipment does cause harmful interference to radio or television reception, which can be determined by turning the equipment off and on, the user is encouraged to try to correct the interference by one or more of the following measures:

- Reorient or relocate the receiving antenna.
- Increase the separation between the equipment and receiver.
- Connect the equipment into an outlet on a circuit different from that to which the receiver is connected.
- Consult the dealer or an experienced radio/TV technician for help.

FCC Radiation Exposure Statement:

This equipment complies with FCC radiation exposure limits set forth for an uncontrolled environment .This equipment should be installed and operated with minimum distance 20cm between the radiator & your body.

This transmitter must not be co-located or operating in conjunction with any other antenna or transmitter.