

---

**Neo\_GM650**

**User Manual**

**Version V1.0**

有方科技 NEOWAY

Shenzhen Neoway Technology Co.,Ltd

---

## Copyright Statement

Copyright © 2008 Neoway Technology

All rights reserved by Shenzhen Neoway Technology Co.,Ltd.



The trademark  belongs to Shenzhen Neoway Technology Co.,Ltd. Other trademarks in this manual belongs to their owners.

## Clarification

This specification is for system engineer, research engineer and test engineer.

As the upgrading of the product version or some other reasons, we'll do some necessity updating to the content of this specification without advance notice.

Unless we have other additional assumpsit, all statements, information and suggestions in this manual do not constitute any express or implied guarantees.

Shenzhen Neoway Technology Co.,Ltd can supply all the technological support. If you have any problem, please feel free to contact to the sales representative or send E-mail to these two mailboxes:

[Sales@neoway.com.cn](mailto:Sales@neoway.com.cn)

[Support@neoway.com.cn](mailto:Support@neoway.com.cn)

Website: [www.neoway.com.cn](http://www.neoway.com.cn)

# Contents

<b>1</b>	<b>Overview</b>	<b>5</b>
<b>2</b>	<b>Figuration</b>	<b>5</b>
<b>3</b>	<b>Block Diagram</b>	<b>6</b>
<b>4</b>	<b>Character</b>	<b>6</b>
<b>5</b>	<b>Pin Definition &amp; Encapsulation</b>	<b>9</b>
5.1	Pin Definition	9
5.2	PCB Packaging	12
<b>6</b>	<b>General AT Commends</b>	<b>13</b>
<b>7</b>	<b>Call Control Commends</b>	<b>13</b>
<b>8</b>	<b>TCP/UDP AT Commends</b>	<b>13</b>
<b>9</b>	<b>GPS AT Commends</b>	<b>13</b>
<b>10</b>	<b>Assembling</b>	<b>13</b>

## Revision Record

Version	Content Revised	Effective date
V1.0	Initial version	2012-06

# 1 Overview

GM650 is an open platform that supports GSM/GPRS+GPS wireless industry module, reserved CPU resources and a wealth of hardware interface which is widely used in various industrial and commercial fields to provide high quality voice, message, data business, GPS Location and other functions.

GM650 provide two kinds of GPS data interface mode: single-port and dual-port. If the user's MCU has only one UART interface, while need to support both GPRS communications and GPS positioning function, that GM650 single-port mode provides the perfect solution.

# 2 Figuration

Table 2-1 GM650 Figuration Specification

Specifications	Description
Dimensions	30.0mm*24.0mm*2.7mm(length*width*height)
Weight	3.7g
Overview	

### 3 Block Diagram

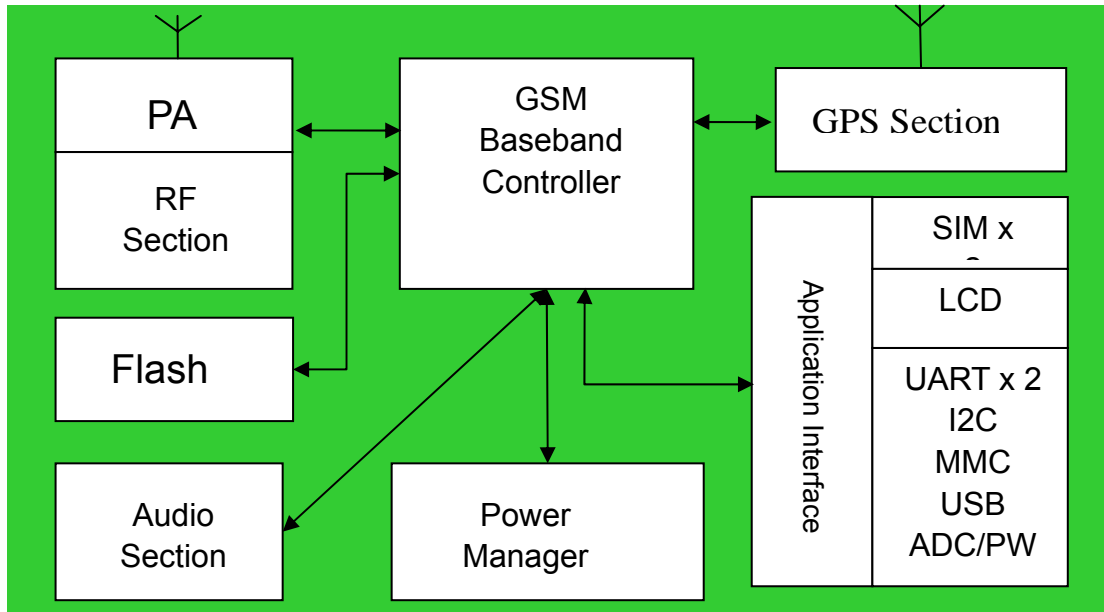

### 4 Character

Table 4-1

General parameters	Description
Operating temperature	-30 ~ +70
Operating voltage	3.5V ~ 4.3V ( recommendation 3.9V )
Operating Current	See table 4-2 and 4-3
Storage temperature	-40 ~ +80
Humidity range	0% ~ 95%

Table 4-2

GSM Specifications	Description
Frequency	900/1800/850/1900
Sensitivity	< -106dBm
The Maximum transmission Power	850/900 Class4(2W) 1800/1900 Class1(1W)
Protocol	Compatible with GSM/GPRS Phase2/2+
AT	GSM07.07 Extended command sets
Audio	FR、EFR、HR、AMR voice coding

SMS	TEXT/PDU
	Point to point/cell broadcast
Grouped Data	GPRS CLASS 12
Coding scheme	CS1~CS4
Mobile Station type	Class B
Circuit Switched Data	Support CSD data service
	Support USSD
Supplement Service	Call forward ( CFB,CFNA,CFU )
	Call waiting
	Threeway calling
Main Processor	ARM7-EJ@104MHz, 32Mbits SRAM,32~64Mbits Nor Flash
Reserved software resource	16Mbits RAM , 16~32Mbits Flash
Reserved software resource	UART x 2 , I2C , LCD ( SPI ) , MMC , USB , ADC , PWM , GPIO x 20 , Keypad
Instantaneous Current	Max 1.8A
Average working Current	< 300mA
Standby Current	2.5mA typ.

Table 4-3

GPS Specifications	Description
GPS C/A coding	1.023 MHz chip rate
GPS Channel	48 channels tracking
GPS Sensitivity	-162dBm
Position Accuracy	10m
Speed Accuracy	0.01 m/s
Time Accuracy	Synchro with GPS Satellite time ( <60ns )
Time of hot start	<1s
Time of warm start	<35s
Time of cold start	<35s
Time of recapture	<0.1s

GPS data updating frequency	2HZ
Height limit	18288m
Speed limit	515 m/s or 1854Km/h
Acceleration limit	<4g
Average working current ( tracking mode )	< 38mA
Average working current ( getting posotion )	< 45mA

**Note:** The starting time, working current and other parameters of GPS is related to testing environment, including whether is under open sky, the thickness of the clouds and so on.



## 5 Pin Definition & Encapsulation

### 5.1 Pin Definition

The signal connection uses 74pin SMD pad of stamp hole(half hole).

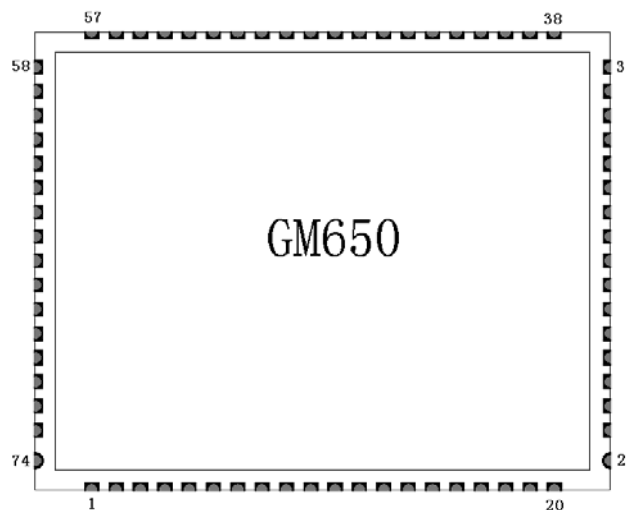

**Note:** GM650 module IO interface level is 2.8V.

Because the module IO uses 2.8V power supply system, the maximum input voltage of all the IO interface can not exceed the maximum 3.3V, otherwise it may damage the module IO. Considering the signal integrity designing reasons, while the external circuit use 3.3V power system the IO interface output voltage will exceed 3.3V because of overshoot phenomenon, sometimes can even reach 3.5V. Therefore, the IO pin of the module will be damaged if 3.3V IO signal is connected to 2.8V IO of the module directly. So it is needed to adopt level matching measures. Please refer to chapter 6.2.

**Table 5-1 GM650 Pin Definition**

Pin	Signal Name	I/O	Function Description	Remark
1	GND	PWR	Ground	
2	Reserved		Reserved	
3	Reserved		Reserved	
4	URXD1	DI	UART1 data receiving	Used to GPRS communications and AT commands
5	UTXD1	DO	UART1 data transmitting	
6	NC		Reserved	suspend, without any signal input.
7	UTXD2	DO	UART2 data transmitting, baud rate = 9600	Dual-port mode, used to receive GPS data; Single-port mode, suspend.

8	Reserved	DO	PWM output	Must externally connect 100k pulldown resistor
9	GND	PWR	Ground	
10	Reserved		Reserved	
11	Reserved		Reserved	
12	VCCIO	AO	2.8V output	Can be supplied to IO level shift circuit,loading capacity<50mA
13	VRTC	PWR	RTC power	2.8V , the highest output current is 2mA
14	BACK_LIGHT	DO	working station indicator,output square signal of 0.5S high level,1.5Slow level	High level light LED , need to parallel connect a capacitor of 0.1uF
15	Reserved		Reserved	
16	Reserved		Reserved	
17	RESET	DI	Reset	Soft reset input,low level reset
18	Reserved		Reserved	
19	Reserved		Reserved	
20	GND	PWR	Ground	
21	ANT_GSM	I/O	GSM antenna RF interface	
22	GND	PWR	Ground	
23	DTR	DI	Low power consumption set	
24	Reserved		Reserved	
25	Reserved		Reserved	
26	Reserved		Reserved	
27	KCOL0	DI	Keyboard column scan 0	While using the serial interface to update software version,pin27 KCOL0 must be high level
28	ON/OFF	DI	ON/OFF input	low level pulse can change ON/OFF state.
29	Reserved		Reserved	
30	Reserved		Reserved	
31	Reserved		Reserved	
32	RING	DO	Ring output	
33	Reserved		Reserved	
34	Reserved		Reserved	
35	Reserved		Reserved	
36	Reserved		Reserved	
37	GND	PWR	Ground	
38,39	VBAT	PWR	Main Power	3.5V~4.3V , recommend 3.9V

40	Reserved		Reserved	
41	Reserved		Reserved	
42	Reserved		Reserved	
43	Reserved		Reserved	
44	GND	PWR	Ground	
45	Reserved		Reserved	
46	Reserved		Reserved	
47	Reserved		Reserved	
48	Reserved		Reserved	
49	VSIM1	PWR	Power of SIM card 1	Compatible to 1.8/3.0V SIM card
50	SIM1_CLK	DO	Clock of SIM card 1	
51	SIM1_RST	DO	SIM card 1 reset	
52	SIM1_DATA	DIO	Data input&output of SIM card 1	Built-in 5K pull-up resistor
53	GND	PWR	Ground	
54	MICP	AI	Positive electrode of MIC audio input	Alternating peak voltage≤200mV
55	MICN	AI	Negative electrode of MIC audio input	Alternating peak voltage≤200mV
56	EARN	AO	Positive electrode of earphone audio output	32Ω earphone driving output
57	EARP	AO	Negative electrode of earphone audio output	32Ω earphone driving output
58	SPKN0	AO	Negative electrode of speaker output	Maximum 0.9W@8Ω
59	SPKP0	AO	Positive electrode of speaker output	Maximum 0.9W@8Ω
60	Reserved		Reserved	Build-in internal 100k pull-up resistor.
61	Reserved		Reserved	
62	Reserved		Reserved	
63	Reserved		Reserved	
64	Reserved		Reserved	
65	GND	PWR	Ground	
66	Reserved		Reserved	
67	Reserved		Reserved	
68	Reserved		Reserved	
69	Reserved		Reserved	
70	CLK32K	DO	32.768kHz real time clock output	
71	Reserved		Reserved	
72	Reserved		Reserved	

73	GND	PWR	Ground	
74	ANT_GPS	I/O	GPS antenna interface	RF

## 5.2 PCB Packaging

The signal connection use 74pin SMD pad.The pin is stamp hole(half hole).The pitch is 1.27mm.The PCB encapsulation we recommend is as chart 5-1.Unit:mm

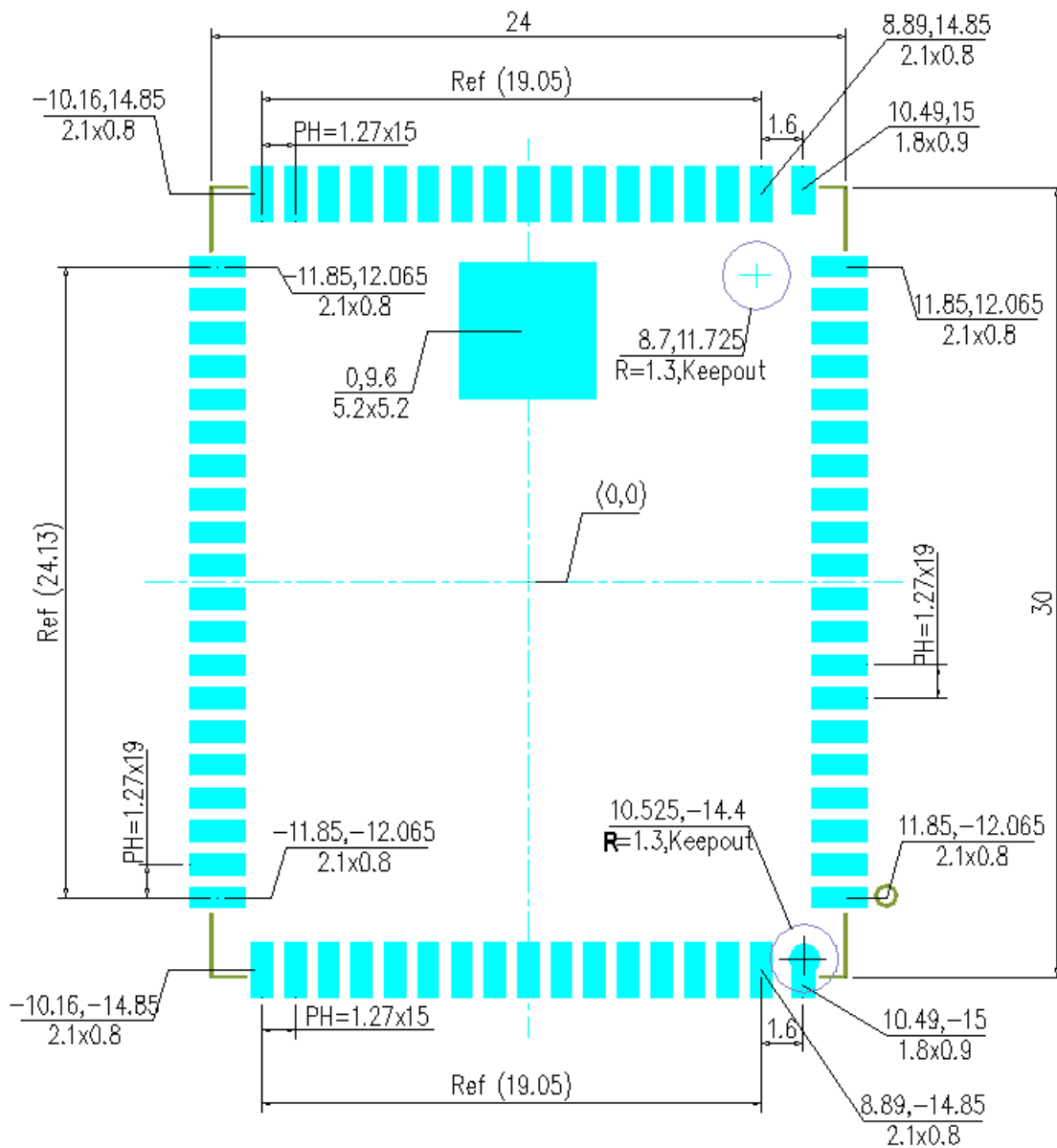

**Chart 5-1 Recommend PCB packaging ( topview )**

**Note :**The number in the brackets stand for coordinate figure of the pad.The original point is

the center of the module.

The number below the coordinate figure stand for shape size of the pad's LxW.

The top right corner and the bottom right corner is two circle regions(R=1.3).The circle regions are route keep out regions.

## 6 General AT Commands

CHECK THE MANUFACTURE	AT+CGMI
QUERY MODULE MODEL	AT+CGMM
QUERY VERSION	AT+GETVERS
GET SEQUENCE NUMBER	AT+CGSN
GET INTERNATIONAL MOBILE SUBSCRIBER IDENTIFICATION	AT+CIMI
GET SIM CARD IDENTIFICATION	AT+CCID

## 7 Call Control Commands

CALL ANSWERING	ATA
DIALING COMMANDS	ATD
HAND UP CALLS	ATH

## 8 TCP/UDP AT Commands

ESTABLISH PPP LINK	AT+XIIC
ESTABLISH TCP LINK	AT+TCPSETUP
SEND TCP DATA	AT+TCPSEND
CLOSE TCP LINK	AT+TCPCLOSE
ESTABLISH UDP LINK	AT+UDPSETUP
SEND UDP DATA	AT+UDPSEND
CLOSE UDP LINK	AT+UDPCLOSE

## 9 GPS AT Commands

GPS ON&OFF	AT+GPSPWR
OBTAIN THE GPS DATA	AT+GPSFETCH

## 10 Assembling

In order to prevent the product of GM650 from being affected with damp, caused by

using the SMT way to perform the furnace welding, in the process of production and use of the costumer, we employ the way of damp-proof packing, such as Aluminum Foil Bag, desiccating agent, Humidity Indicator Cards, Suck plastic trays, and vacuolization. As a result the product is kept dry and its life span will be long.

In order to make the SMT way easy, we use the tray to load the product. The user only needs to install it in the chip mounter according to the fixed direction.

GM650 storage and SMT notes, please refer to <Neoway module SMT reflow production recommendation\_V1.0>.

#### FCC Caution

Any Changes or modifications not expressly approved by the party responsible for compliance could void the user's authority to operate the equipment.

This device complies with part 15 of the FCC Rules. Operation is subject to the following two conditions: (1) This device may not cause harmful interference, and (2) this device must accept any interference received, including interference that may cause undesired operation.

Note: This equipment has been tested and found to comply with the limits for a Class B digital device, pursuant to part 15 of the FCC Rules. These limits are designed to provide reasonable protection against harmful interference in a residential installation. This equipment generates uses and can radiate radio frequency energy and, if not installed and used in accordance with the instructions, may cause harmful interference to radio communications. However, there is no guarantee that interference will not occur in a particular installation. If this equipment does cause harmful interference to radio or television reception, which can be determined by turning the equipment off and on, the user is encouraged to try to correct the interference by one or more of the following measures:

- Reorient or relocate the receiving antenna.
- Increase the separation between the equipment and receiver.
- Connect the equipment into an outlet on a circuit different from that to which the receiver is connected.
- Consult the dealer or an experienced radio/TV technician for help.

#### FCC Radiation Exposure Statement:

This equipment complies with FCC radiation exposure limits set forth for an uncontrolled environment .This equipment should be installed and operated with minimum distance 20cm between the radiator & your body.

This transmitter must not be co-located or operating in conjunction with any other antenna or transmitter.