



FCC Part 15 Subpart C

**Frequency Hopping
Spread Spectrum Transmitter**

Certification Test Report

Appendix H

Installation Guide

Manufacturer: Neptune Technology Group

Model: R900-v2

Variants: ♦ **Pit Mounted MIU with External Antenna**
♦ **Wall Mounted MIU with Integrated Antenna**

FCC ID: P2SNTGSRFV2

ACS Report Number: 02-0177-15C

3. Information to User

FCC Notice

This device complies with part 15 of the FCC rules. Operation is subject to the following two conditions: (1) This device may not cause harmful interference, and (2) this device must accept any interference received, including interference that may cause undesired operation.

“NOTE: This equipment has been tested and found to comply with the limits for a Class B digital device, pursuant to Part 15 of the FCC Rules. These limits are designed to provide reasonable protection against harmful interference in a residential installation. This equipment generates, uses and can radiate radio frequency energy and, if not installed and used in accordance with the instructions, may cause harmful interference to radio communications. However, there is no guarantee that interference will not occur in a particular installation. If this equipment does cause harmful interference to radio or television reception, which can be determined by turning the equipment off and on, the user is encouraged to try to correct the interference by one or more of the following measures:

- Reorient or relocate the receiving antenna.
- Increase the separation between the equipment and receiver.
- Connect the equipment into an outlet on a circuit different from that to which the receiver is connected.
- Consult the dealer or an experienced radio/TV technician for help.”

RF Exposure Information

This equipment complies with the FCC RF radiation requirements for uncontrolled environments. To maintain compliance with these requirements, the antenna and any radiating elements should be installed to ensure that a minimum separation distance of 20cm is maintained from the general population

Caution:

Changes or modifications not expressly approved by the party responsible for compliance could void the user's authority to operate the equipment.

Professional Installation

In accordance with section 15.203 of the FCC rules and regulations, the MIU must be professionally installed by trained utility meter installers.

4. Installation guide

The N-901 MIU is designed for use with four types of encoder registers: Neptune ARB V, ProRead, Sensus ECR II & Invensys ECR III. Before installing an MIU, the encoder registers must be correctly wired and/or programmed to work with the MIU.

Note: When a ProRead encoder register is used, the ProRead register must be programmed for three-wire mode.

If the MIU will be connected to a new ProRead encoder register, or if a three-conductor cable is already connected to a ProRead encoder register, ensure that the ProRead register is programmed for three-wire mode using the ProRead programmer and its RF/MIU 6, 8, or 10 ID TDI format. This can be accomplished through the ProRead receptacle before removing the receptacle.

Wiring the encoder register

Run a three-conductor cable from the encoder register to the MIU.
Refer to the steps below.

Connect the 3-conductor wire to the encoder register’s terminals per the manufacturer’s instructions, using the color code in Table 1.

1. Thread the cable around the strain relief posts of the encoder.
2. Apply moisture protection compound to the terminal screws and exposed wires. (Neptune recommends Dow Corning® Compound #4).
3. Snap the cover onto the encoder register.
4. Proceed to the section entitled “Installing the MIU.”

Table 1

<i>Encoder Register</i>	Wire Color / Encoder Terminal		
Neptune ARB V	Black / B	Green / G	Red / R
Neptune ProRead	Black / B	Green / G	Red / R
Neptune E-Coder	Black / B	Green / G	Red / R
Sensus ECR11	Black / R	Green / B	Red / G

Testing the MIU Installation

After the MIU has been installed and wired, follow these steps to verify that the MIU is working properly:

Power up the handheld unit (HHU) test device and start the testing program provided.

Warning:

To avoid RF signal saturation of the HHU, position the receiver at least 2 to 3 feet from the MIU.

When the MIU is installed correctly, its MIU ID and a meter reading will appear on the HHU’s display within one minute. Verify that this is the correct meter reading by comparing it to the meter’s dial.

If a meter reading does not appear on the HHU’s display or the meter reading in the HHU’s display is not the same as the reading on the meter’s dial:

Reactivate the MIU using the magnet.

Verify all electrical connections.

Test the installation again (repeat above steps).

If a ProRead Encoder Register is used:

Insure the unit is programmed in “3-wire mode”.

Verify all electrical connections.

Reactivate the MIU using the magnet

If a problem still exists contact your Neptune representative.

Pit MIU Installation

Note: Before wiring the encoder register, make sure the cable is long enough so that when the installation is complete, the pit lid (with MIU attached) can be removed easily without straining the cable.

1. Feed the antenna cable and housing through the 1 3/4" hole in the meter pit lid. Slip the large plastic nut over the antenna cable and thread it onto the antenna assembly to secure it to the pit lid (Figure 1).
2. Connect the coaxial cable connector to the connector on the transmitter housing (Figure 2).
3. Making sure the washer is properly seated, connect the plastic connector housing to the 3-lobed black plastic latch-plate (Figure 3).
4. Slide the black conical-shaped gasket down the cable until it engages the connector housing (Figure 4).
5. Tighten the connector nut onto the threaded portion of the connector housing (Figure 5).
6. If desired, use the included cable tie to hang the MIU from the antenna tube (Figure 6).
7. Place the magnet against the side of the MIU in the area shown and swipe it in the indicated direction to activate the MIU (Figure 7).

Wall MIU Installation

Gel caps should be used to connect the pigtail from the MIU to the register wire.

When using the Scotchlok gel caps, **pair the wires according to the color chart in Table 1**. With the ends of the colored wires stripped approximately 1/4", slide the pair into the gel cap as far as they will go. Then, firmly squeeze the gel cap with an appropriate crimping tool. One gel cap should be used for each colored wire pair.

(See picture 9.)

Proceed to the section entitled "Installing the MIU."

Installing the Wall MIU

1. Attach the mounting adapter to the wall using the appropriate holes.
2. Storing the excess wire in the hollow cavity on the back of the MIU, slide the tongue on the top of the MIU into the groove on the top of the mounting adapter (Figure 10).
3. Secure the MIU to the mounting adapter using the Hi/Lo fastener provided (Figure 11).
4. Place the magnet against the side of the MIU in the area shown and swipe it in the indicated direction to activate the MIU (Figure 12).

Note: For best performance in Fixed-Network configuration, wall MIU may be mounted horizontally.

PIT MIU Installation

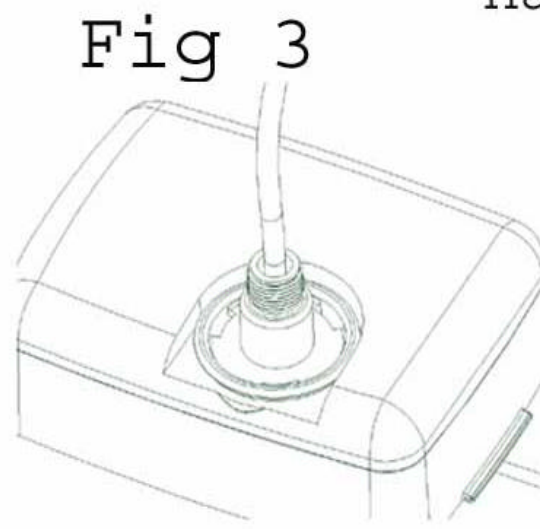
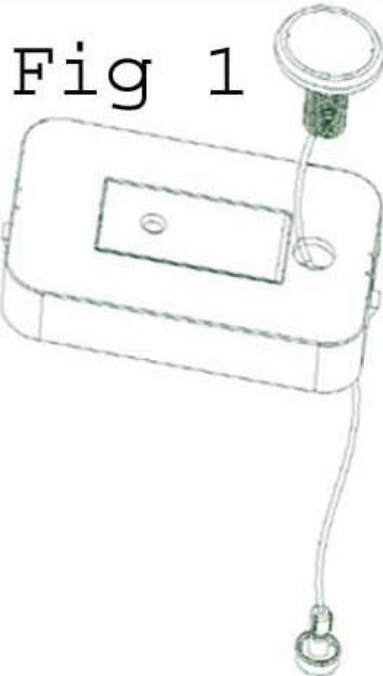

PIT MIU Installation

Fig 5

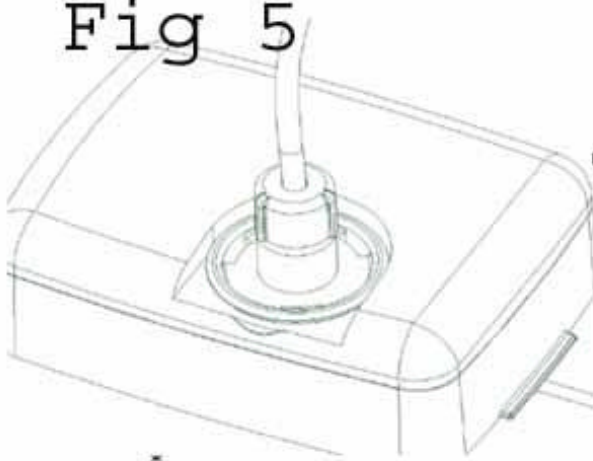

Fig 6

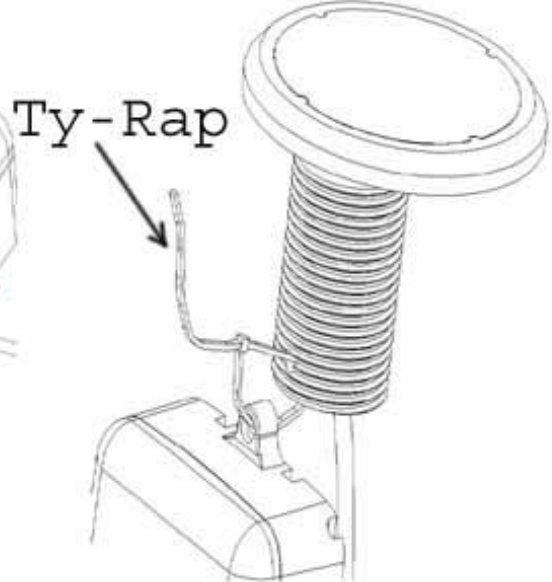

Fig 7

Activation Magnet

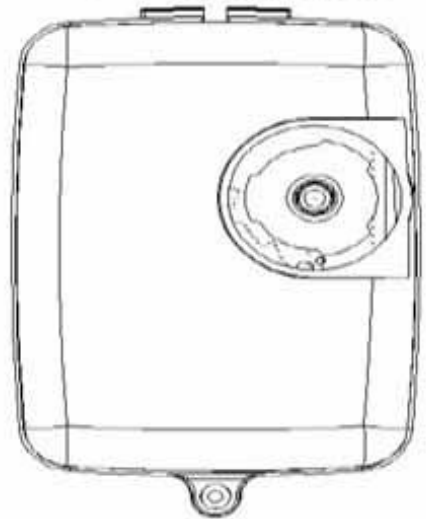

Fig 8

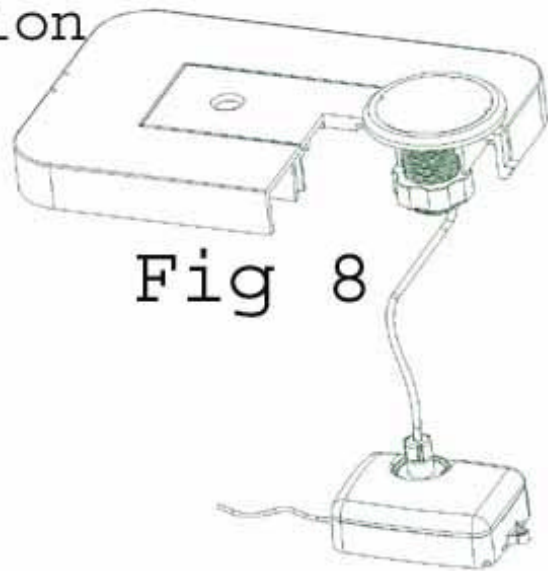
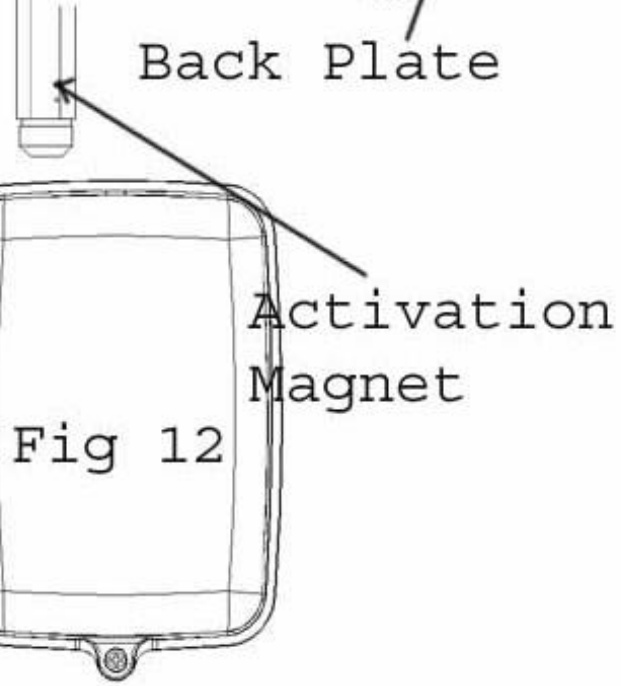
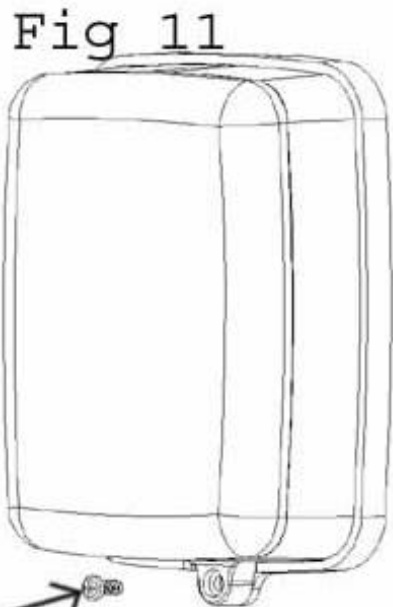
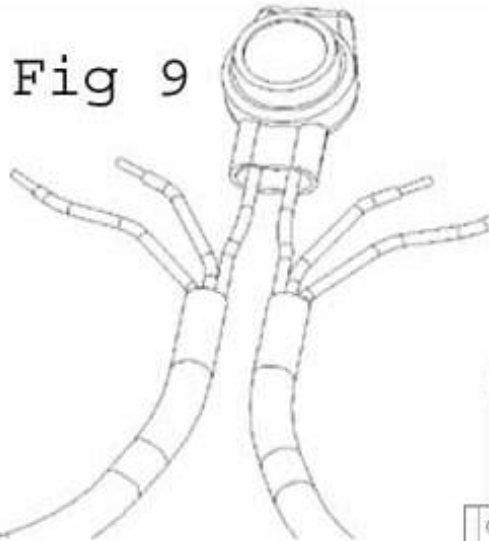

Figure 6

WALL MIU Installation



Hi-Lo Fastener