

# User Guide

NTC-3000 Series - M2M Serial Modem



## Copyright

Copyright©2013 NetComm Wireless Limited. All rights reserved.

The information contained herein is proprietary to NetComm Wireless Limited. No part of this document may be translated, transcribed, reproduced, in any form, or by any means without prior written consent of NetComm Wireless Limited.



Please note: This document is subject to change without notice.

## Save Our Environment

When this equipment has reached the end of its useful life, it must be taken to a recycling centre and processed separately from domestic waste.

The cardboard box, the plastic contained in the packaging, and the parts that make up this device can be recycled in accordance with regionally established regulations. Never dispose of this electronic equipment along with your household waste. You may be subject to penalties or sanctions under the law. Instead, ask for disposal instructions from your municipal government.

Please be responsible and protect our environment.

This manual covers the following products:

NetComm NTC-3000-01

NetComm NTC-3000-02

NetComm NTC-3000-03

<i>DOCUMENT VERSION</i>	<i>DATE</i>
1.0 - Initial document release	26/04/2013
1.1 - Updated layout of Hardware Installation and Establishing a Mobile broadband connection sections. Updated descriptions of interfaces.	24/06/2013
1.2 - Added NetComm Wireless OpenAT Custom Application section based on software version 1.0.13	12/09/2013

1.3 – Corrected RJ-45 to DB9 Serial/Power Adapter Cable diagram	27/11/2013
---	------------

*Table 1 - Document Revision History*

# Table of Contents

Overview .....	5
Safety and Product Care .....	6
Product Introduction .....	7
Physical Dimensions and Indicators .....	8
LED Indicators .....	8
Physical Dimensions .....	8
Interfaces .....	9
Hardware Installation .....	10
Inserting the SIM card .....	10
Mounting the device .....	11
Connecting the Data / Power cables .....	13
Establishing a Mobile broadband connection .....	18
Using the Mini USB port .....	18
Using the RJ-45 connector .....	20
Communicating with an NTC-3000 Series Modem .....	27
Dumb Terminal .....	27
Open AT Application Framework .....	29
NetComm Wireless Open AT Custom Application .....	30
Command List .....	30
General Operation .....	43
Technical Data .....	48
Mini USB Connector .....	48
RJ-45 Connector .....	49
RJ-45 to DB9 Serial/Power Adapter Cable .....	49
Electrical Specifications .....	50
Environmental Specifications / Tolerances .....	50
Product Service and Support .....	51
Troubleshooting .....	51
Web Based Product References .....	52
FAQs .....	52
Appendix A: Tables .....	53
Legal and Regulatory .....	54

# Overview

## Introduction

This document details the process of configuring the NTC-3000 Series device via a terminal emulation program (such as HyperTerminal) as well as mounting and deployment advice.

## Target Users

This document is expected to be utilised by system integrators or experienced hardware installers who are comfortable with all aspects of IP based networking and possess an understanding of serial based technologies such as dialup modems, AT commands and legacy data collection devices.

## Prerequisites

A computer with a terminal emulation program (such as HyperTerminal), a serial port, an appropriate power supply and a device to connect to the NTC-3000 Series modem after configuration has been completed.

## Notation

The following symbols are used in this manual:



The following note requires attention



The following note provides a warning









The following note provides relevant information.

# Safety and Product Care

The NTC-3000 series offers a hardened industrial enclosure making it suitable for a variety of remote deployment locations.

With reference to the unpacking, installation, use and maintenance of your electronic device, the following basic guidelines are recommended:

-  Installation, configuration and disassembly should be performed by trained personnel only.
-  Do not use or install this product near water to avoid fire or shock hazard. Avoid exposing the equipment to rain or damp areas.
-  Do not use or install this product in extremely hot or cold areas. Ensure that the device is installed in an area where the temperature is within the supported operating temperature range (-40°C to 85°C).
-  Arrange any cables in a manner such that they are not likely to be stepped on or have items placed on them.
-  Ensure that the voltage and rated current of the power source match the requirements of the device. Do not connect the device to an inappropriate power source.
-  Use only a clean, dry cloth to wipe the device. Never apply chemical cleaners on the device.

## WARNING:

Disconnect the power line from the device before servicing.

## Transport and Handling













When transporting the NTC-3000 Series, it is recommended to return the product to the original packaging. This ensures the product will not be damaged.



In the event the product needs to be returned, ensure it is securely packaged with appropriate padding to prevent damage during courier transport.



# Product Introduction

## Product Overview



-  Small-sized and rugged industrial-grade 3G modem for wireless data communication
-  Provides reliable RS232 serial data connectivity for various M2M applications
-  Supports standard AT command set
-  Supports various networks and service types UMTS/HSDPA/HSUPA & GSM/GPRS/EDGE
-  Embedded Internet and security protocol stacks
-  Wide input voltage range 5-36V DC suitable for diverse environments and applications
-  RS232 serial data connection and power input via RJ45 port
-  USB 2.0 port for communicating (e.g. Dial-up networking from Windows PC and Mac)
-  Supports Open AT and AirVantage
-  DIN rail and wall mount option with removable mounting bracket
-  SIM card reader with locking tray
-  Wide operating temperature range -40 to 85°C

## Package Contents

The NTC-3000 series package consists of:

-  NTC-3000 Series Modem
-  Quick Start Guide

The following items are available as optional accessories:

-  External antenna
-  DB9 serial/power adapter cable
-  Mounting bracket

If any of these items are missing or damaged, please contact NetComm Support immediately by visiting the NetComm Support website at: <http://support.netcommwireless.com/>.

## Product Features

The NTC-3000 Series is a reliable solution for cost effective deployment in any data telemetry environment. Designed for reliable performance and universal installation it provides 3G data connectivity for M2M applications enabling remote monitoring, control, management and reporting of industrial and commercial equipment.

The small and rugged form factor is ideal for applications such as metering, rail, road signs, security, transport and vending machines. It can also be used in SCADA (Supervisory Control and Data Acquisition) scenarios to monitor, control or collect data from remote devices such as farm machinery, water monitoring devices and wind farms.

A serial connection on one end and a 3G connection on the other allows the devices to simply take the serial data and send it over 3G. When connecting through the RJ-45 port to the serial port of your device, the broadband connection can be established using AT commands in a terminal emulator or through the use of a Windows Dial Up Networking profile. The modem also comes equipped with a Mini USB port where a connection can be established through either a virtual COM port or Sierra Wireless's AirCard Watcher application.

The lockable SIM tray along with the rugged nature of the device means you can be assured that your device is working reliably, regardless of the physical location.

# Physical Dimensions and Indicators

## LED Indicators

The NTC-3000 Series uses two LEDs to display the current system and connection status.

LED INDICATOR	COLOUR	DEFINITION
Power	Off	The Power is off.
	Red	The Power is on and the NTC-3000 is operating normally.
3G	Off	The NTC-3000 is not connected to a 3G network.
	Slow flashing green	The NTC-3000 is attempting to connect to a 3G network.
	Quick flashing green	Data is moving across the 3G connection.

Table 2 - LED Indicators

## Physical Dimensions

The following page lists the physical dimensions of the NTC-3000 Series as well as the physical dimensions of the mounting bracket which can be used to attach the NTC-3000 Series to a Type-O DIN Rail or to provide a wall / ceiling mount.



Figure 1 - NTC-3000 Series Dimensions

NTC-3000 SERIES	
Length	74 mm
Width	24 mm
Height	57 mm
Weight	84g (w/o mounting bracket and antenna)

Table 3 - Device Dimensions

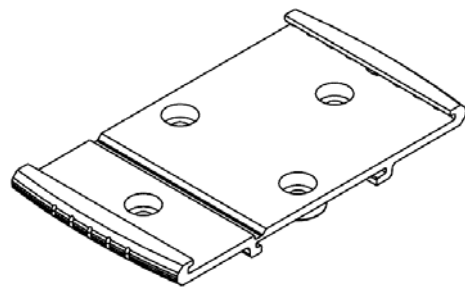

Figure 2 - NTC-3000 Series Mounting Bracket

MOUNTING BRACKET	
Length	80 mm
Width	45 mm
Height	5 mm
Weight	10g (w/o NTC-3000 attached)

Table 4 - Mounting Bracket Dimensions



# Interfaces

The following interfaces are available on the NTC-3000 Series:

INTERFACE	FUNCTION
RJ-45 (RS-232 DB-9 adapter / Power)	Provides a serial interface via a standard Windows modem for AT command communication and dial-up networking. The serial modem may also be powered from this interface using the DB-9 adapter / power cable. Refer to the <a href="#">Technical Data</a> section of this manual for more information.
Mini USB	Provides a serial interface via a virtual COM port for AT command communication and dial-up networking. Requires that the SWI driver and 3G watcher application are installed. The serial modem may be powered from the Mini USB port.

*Table 5 - Integrated Devices*



Note: The driver required for the mini USB virtual COM port and AirCard Watcher application are available from the NTC-3000 Series Product Support page at: <http://support.netcommwireless.com/product/m2m/ntc-3000>

# Hardware Installation

## Inserting the SIM card

Please ensure that the NTC-3000 is not connected to the power cable before proceeding.

1. Push the small yellow button besides the SIM card holder.

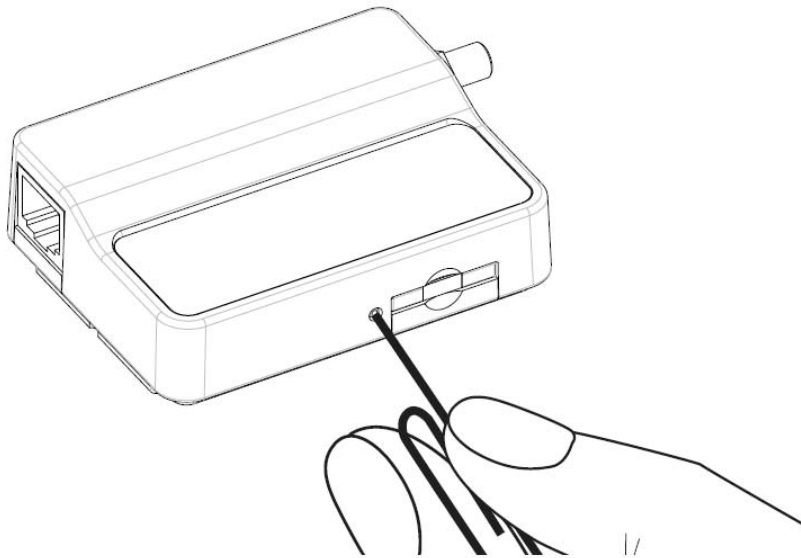

Figure 3 – Accessing the NTC-3000 SIM Card Slot

2. Insert the SIM card into the holder with the golden SIM conductor pins facing up.

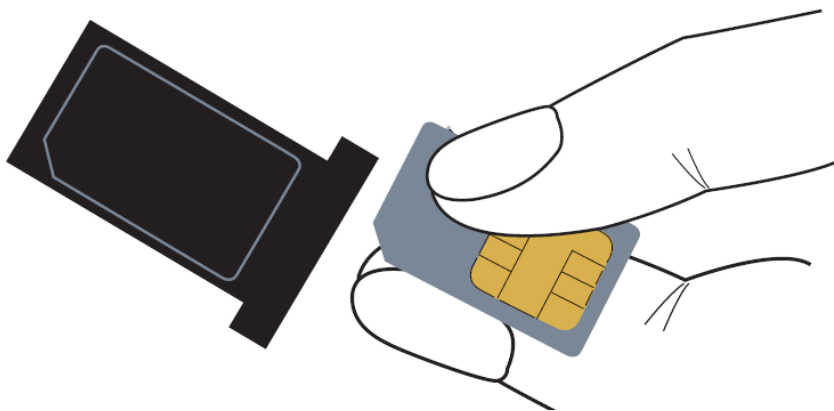

Figure 4 - Inserting a SIM Card into the NTC-3000 SIM Card Holder

3. Insert the loaded SIM card holder with the SIM conductor pins facing down into the NTC-3000.

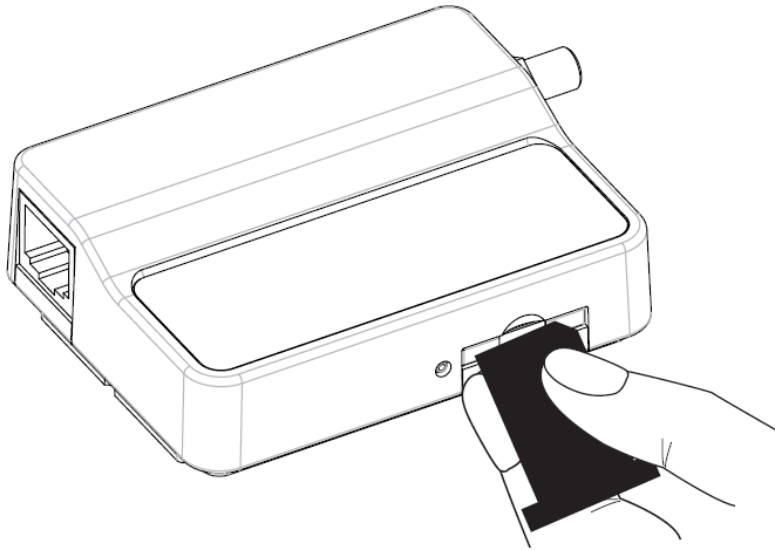

Figure 5 –Face Down Insertion of the SIM Card and SIM Card Holder

## Mounting the device

The NTC-3000 series modem can be mounted on the wall or a DIN rail by using the mounting bracket. The mounting bracket is made from polyamide, which is a flexible material.

Mounting the NTC-3000 series modem is as simple as bending the mounting bracket to snap into place on the Type-O (Top Hat) DIN rail. This holds the NTC-3000 series modem in place securely.

Alternatively, the mounting bracket can be screwed onto a wall to provide a permanent fixture.

### DIN rail mounting

The NTC-3000 Series mounting bracket has been designed to fit a TS 35 Type-O DIN rail with a 25mm core.

1. Bend / Flex the mounting bracket at the bend line so that the ridges are able to 'hold' onto the DIN rail edges as per the diagram above. You also have the option of securing the mounting bracket further by screwing it into place on the rail.

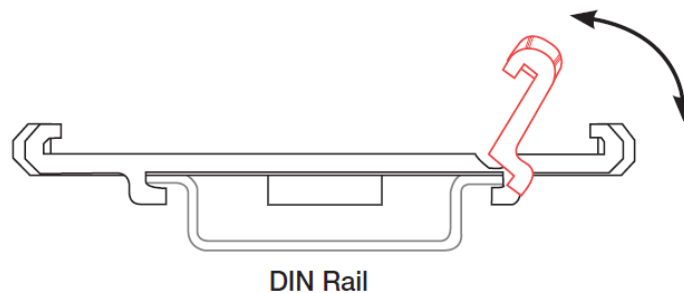
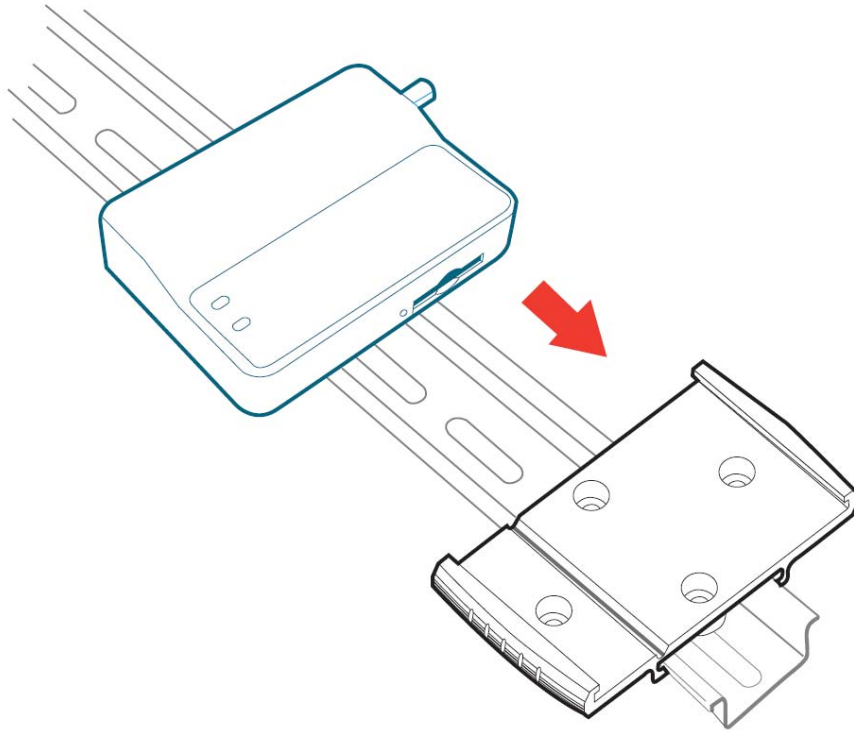

Figure 6 - NTC-3000 - Mounting Bracket - DIN Rail

2. Once the bracket is attached to the DIN rail, slide the NTC-3000 Series modem into the mounting bracket to securely fix it in place.





*Figure 7 - Securing the NTC-3000 Mounting Bracket to the DIN Rail*

#### Wall Mounting

1. Select a position on the wall where you would like to mount the NTC-3000 Series modem. Attach the mounting bracket to the chosen wall or ceiling by using the 4 screw holes (screws not included).
2. Once the bracket is attached to the DIN rail, slide the NTC-3000 Series modem into the mounting bracket to securely fix it in place.

## Connecting the Data / Power cables

There are two methods of connecting the NTC-3000 to your computer:

-  Via RJ-45 connector using a DB9 serial/power adapter cable
-  Via USB 2.0 port using a Mini USB cable

### Connecting via RJ-45 connector

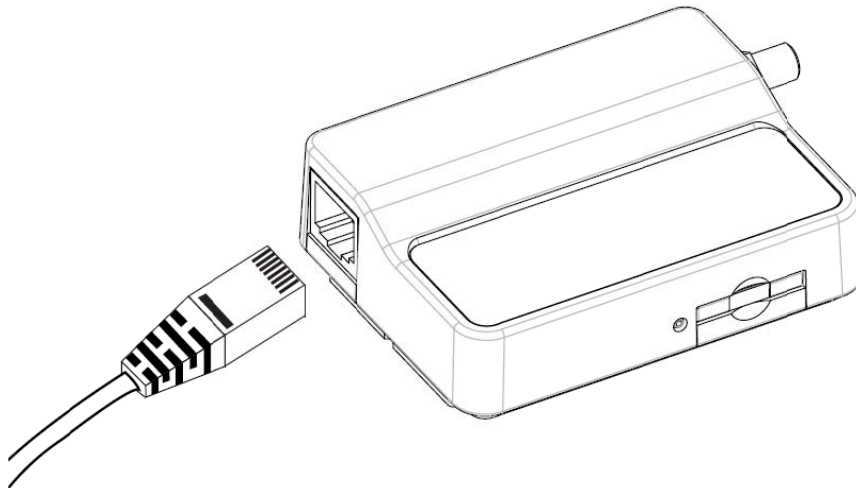

Figure 8 - Connecting the RJ-45 Ethernet / Power Cable to the NTC-3000

1. Connect the optional antenna to the SMA connector of the NTC-3000.
2. Plug the optional RS-232 data/power cable into the RJ-45 socket of the NTC-3000 and then plug the serial port ( ) end into the COM port of the device that will connect to the NTC-3000.
3. Connect a compatible power adapter to the DC power jack (2.1mm barrel) of the RS-232 data/power cable and then plug the power adapter into a power outlet.



Please note: It is not possible to use the mini-USB and Serial connection concurrently. Make sure any open connection on the Serial port is disabled before connecting via the mini-USB cable.



### Connecting via Mini USB port

The mini USB connection enables communication from a Windows computer via a virtual COM port. The NTC-3000 Series modem can then be configured via a terminal emulator (such as HyperTerminal). To configure the internet connection settings of the router, the AirCard Watcher application must be installed on your computer. The Sierra Wireless AirCard Watcher application can also be used to establish the broadband connection and includes the driver necessary to install the modem on your computer. It can be downloaded from the NetComm Wireless Support website at <http://support.netcommwireless.com/product/m2m/ntc-3000> or for the most up to date version of the software, please visit the Sierra Wireless website at <http://www.sierrawireless.com/support.aspx>.

The following procedure demonstrates how to install the AirCard Watcher application on Windows XP:



Note: Do not connect the NTC-3000 Series Router to the computer until the AirCard Watcher application has been installed.

1. Open "My Computer" and navigate to the folder where you saved the AirCard Watcher application.
2. Double-click on the Watcher\_Generic.msi file to open the installation wizard. The AirCard Watcher Installation Welcome screen is displayed. Click **Next >** to begin the installation.



Figure 9 - AirCard Watcher InstallShield Wizard Welcome Screen

3. The End User License Agreement is displayed. If you agree with the terms of the agreement select "I accept the terms in the license agreement". If you want to change the location that the application is installed to, click the **Change** button and choose the location to install the application. Click **Next >** to continue.



Figure 10 - AirCard Watcher InstallShield Wizard End-User License Agreement Screen

4. The installation wizard will proceed to install the software and when it has finished, the InstallShield Wizard Completed screen is displayed. Click **Finish** to close the wizard.

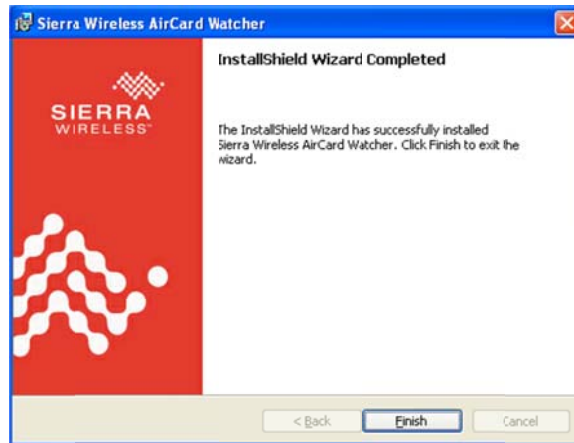

Figure 11 - AirCard Watcher InstallShield Wizard Completed Screen

#### Verifying successful installation of the driver

To verify the driver was successfully installed, check in the Device Manager for extra COM ports. To check the Device Manager, perform the following steps:

1. Click on the **Start** button and navigate to the **Control Panel** option.
2. Double click on the **System** Control Panel item.
3. Click on the **Hardware** tab and then click the **Device Manager** button.
4. The Device List displays the following COM ports. Take note of the COM port number of the Sierra Wireless AT Command Port as this will vary depending on your environment and you may wish to use this port to communicate with the modem via a terminal emulator. In this example, it is COM11.



Figure 12 - NTC-3000 USB Driver Installation - Device Manager Details

If the Sierra Wireless COM ports are not listed, please reboot your computer and attempt the installation again. If this still fails, please contact NetComm Wireless Technical Support at <http://support.netcommwireless.com/>





# Establishing a Mobile broadband connection

## Using the Mini USB port

The NTC-3000 Series Routers can use the Sierra Wireless AirCard Watcher application to establish an internet connection. To begin using the NTC-3000 Series Router:

1. Connect the NTC-3000 to your computer using a mini USB cable. The AirCard Watcher application should automatically start up and if your SIM card is PIN locked, it will prompt you for the PIN to unlock it. Enter the PIN and click **SEND**.

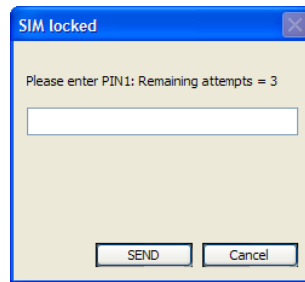



Figure 13 - SIM locked PIN Prompt

2. When the PIN is verified, the AirCard Watcher application will be displayed:



Figure 14 - AirCard Watcher Main Screen

3. In many cases you will be able to click the Connect button to establish a connection immediately if the software was able to determine a default APN. If not, click the  icon to access the configuration options.
4. Click **Profiles** from the menu on the left and then click  to add a new profile. Enter a Profile Name, Username and Password (if required) and APN (Access Point Name). When you are done click **Apply**.

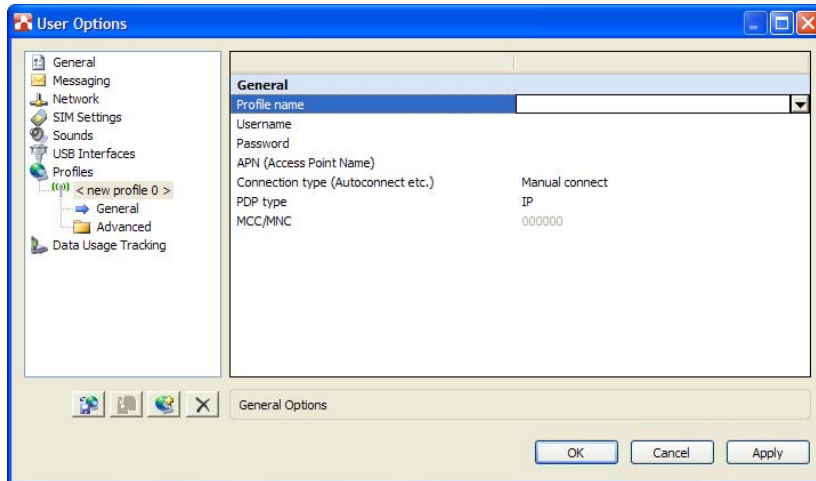

Figure 15 - AirCard Watcher Options - Add New Profile Screen

- With the Profiles menu option selected, use the **Default Profile** drop down list on the right side of the screen to select the profile you created and click **OK**.

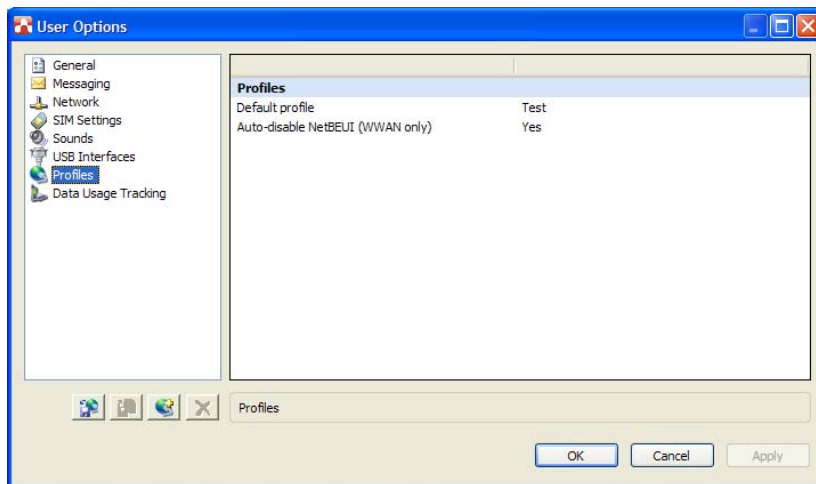

Figure 16 - AirCard Watcher Options - Profiles Options

- Click **Connect** to connect to the mobile broadband network. When you are connected, the Connect button changes to a Disconnect button.



Figure 17 - AirCard Watcher Application – Connected

## Using the RJ-45 connector

The NTC-3000 can be used to dial up to the internet and provide networking using a standard serial modem driver. Example screenshots are shown below to demonstrate this process using Windows XP, however similar steps can be used in other operating systems.

1. Click **Start** and then **Control Panel**.
2. Double click **Phone and Modem Options**.

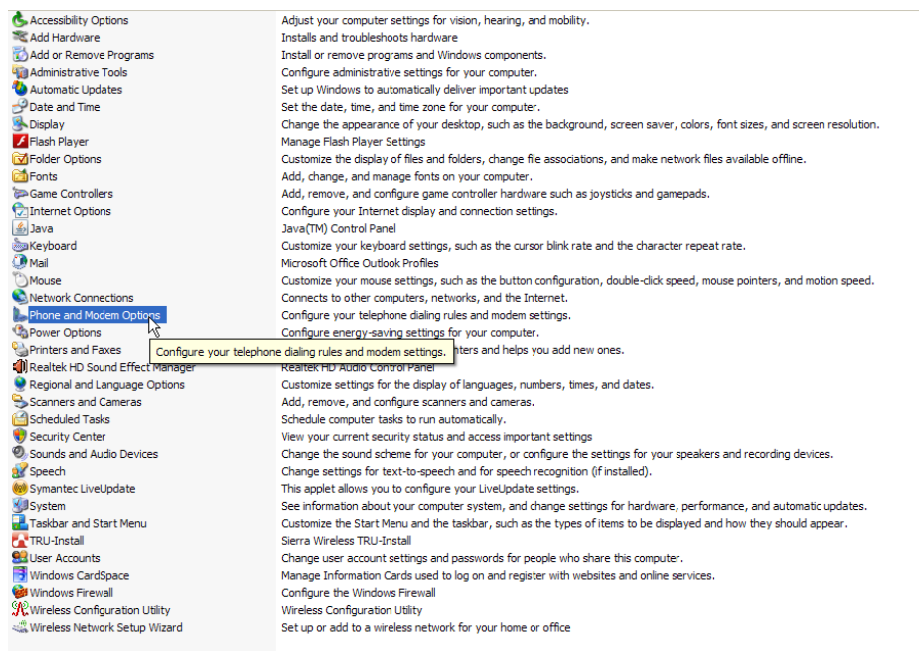

Figure 18 - Control Panel - Phone and Modem Options

3. On the Phone and Modem Options window, click **Add**
4. Select **Don't detect my modem; I will select it from a list** and then click **Next**.



Figure 19 - Add Hardware Wizard - Don't Detect Modem Option

5. Wait a few moments until the list is loaded, then select **Standard 33600 bps modem** from the list, and click **Next**.

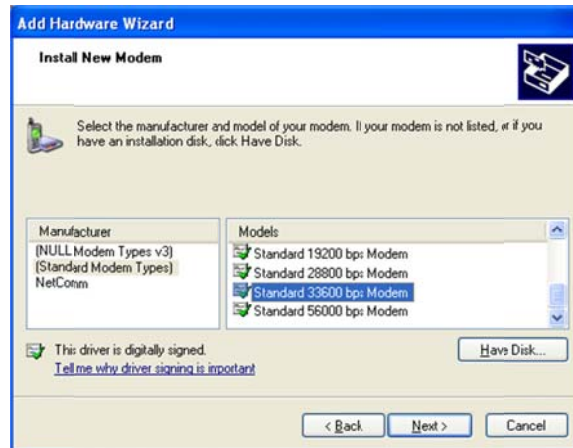

Figure 20 - Add Hardware Wizard - Standard 33600kbps Modem

6. Select the port that the NTC-3000 is connected to and select **Next**. In the example screenshot below, the NTC-3000 is connected via the serial cable to port COM1.



Figure 21 - Add Hardware Wizard - COM1

7. Wait a few moments whilst Windows installs the driver and click **Finish** on the final screen of the wizard.



Figure 22 - Add Hardware Wizard - Modem Installed Successfully

8. The modem must now be modified to add a special initialisation string to pass the APN information required by your service to connect to the cellular network. To do this, ensure that the new modem is selected on the **Phone and Modem** menu, and click **Properties**.

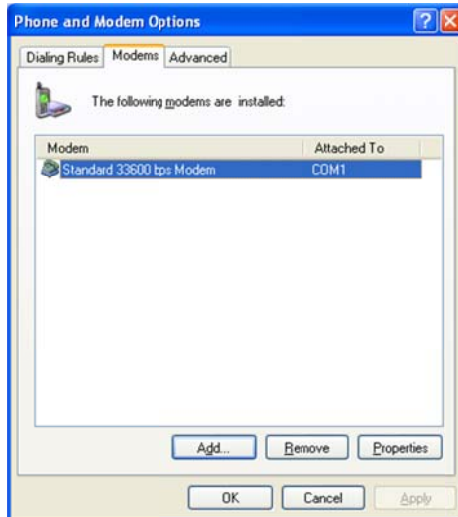

Figure 23 - Phone and Modem Options - Modems Tab

- Click on the **Advanced** tab, and type the following initialization commands in the **Extra initialization commands** field:

**at+cgdcont=1,"IP","apn"**

The 'apn' is your Access Point Name e.g. for Telstra you would type **at+cgdcont=1,"IP","telstra.internet"**

Click **OK**.

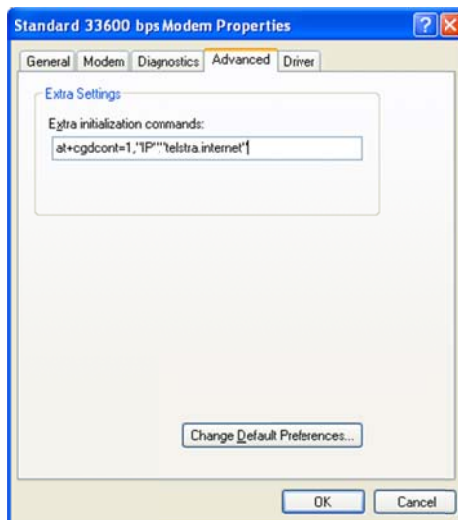

Figure 24 - Standard 33600kbps Modem Properties - Extra initialization commands

- Click on **Start** then **Control Panel**, then double-click on **Network Connections**.
- Click on **File** then **New Connection**.

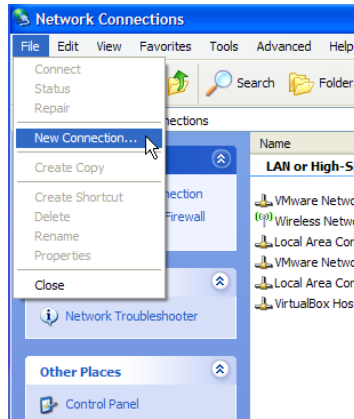

Figure 25 - Network Connections - New Connection

12. The New Connection Wizard is displayed. Click **Next >** to begin.



Figure 26 - New Connection Wizard Welcome Screen

13. Select **Connect to the Internet** and click **Next >**.

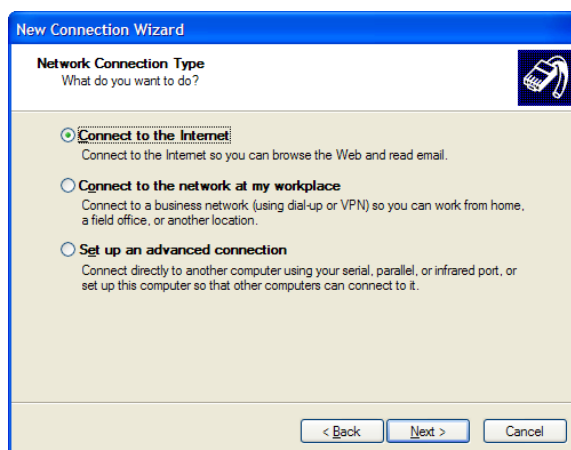

Figure 27 - New Connection Wizard - Connect to the internet

14. Select **Setup my connection manually** and click **Next >**.

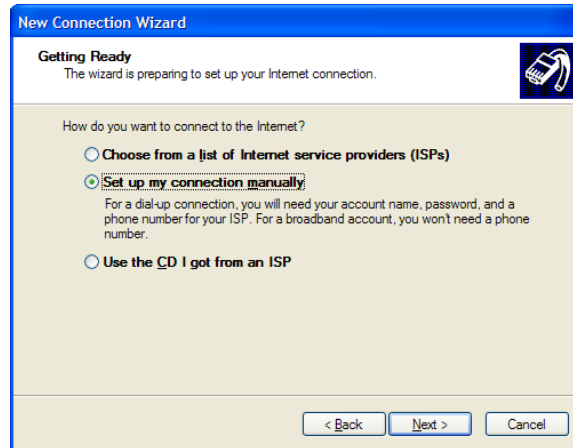

Figure 28 - New Connection Wizard - Set up my connection manually

15. Select Connect using a dial-up modem and click Next >.

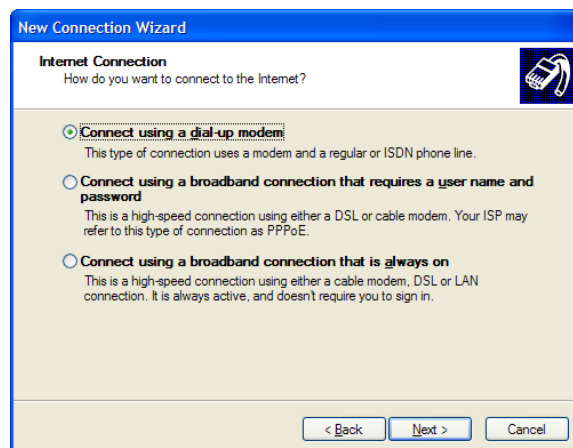

Figure 29 - New Connection Wizard - Connect using a dial-up modem

16. Enter a name for the ISP or connection and click Next >.

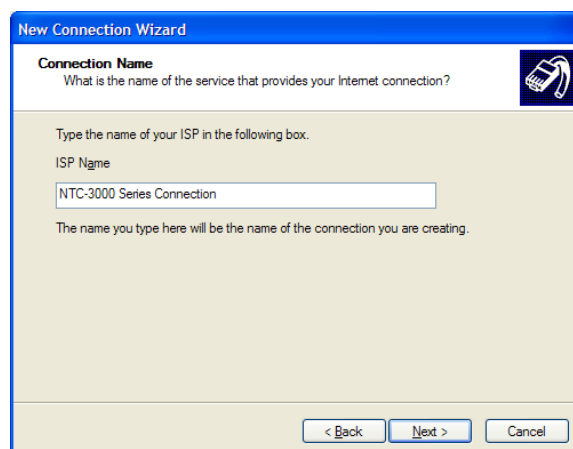

Figure 30 - New Connection Wizard - Connection Name



17. In the Phone Number field, enter \*99\*\*\*1#

Click Next >.

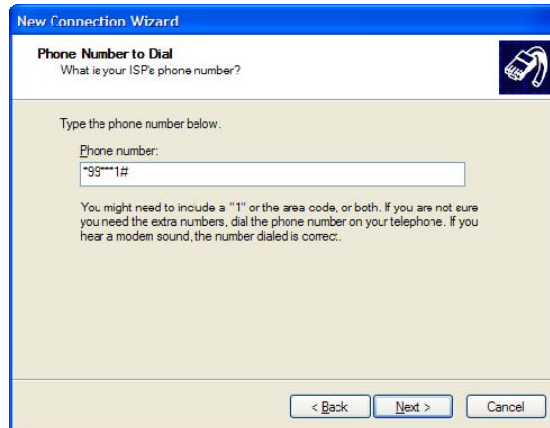

Figure 31 - New Connection Wizard - Phone Number

18. Select For my use only and click Next >.

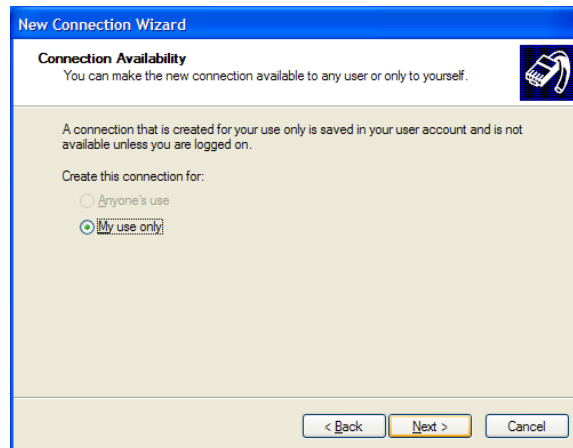

Figure 32 - New Connection Wizard - My use only

19. If the service from your wireless service provider requires authentication, please enter a username/password into the relevant fields. Your service provider can provide this information if they are required. Click Next >.

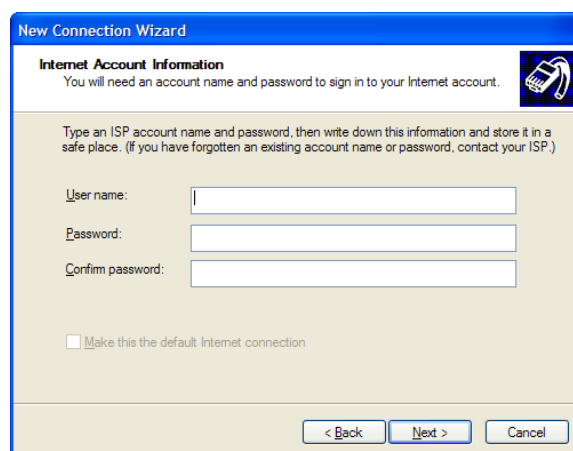

Figure 33 - New Connection Wizard - Username and Password

- 20. Click Finish.

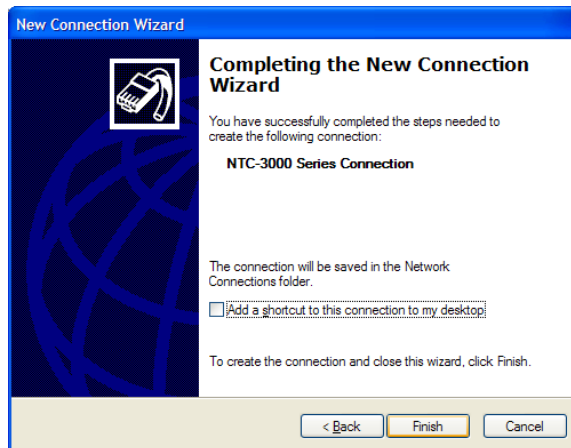

Figure 34 - New Connection Wizard Complete Screen

- 21. When you click Finish, the connection window opens prompting you to establish a connection. Click Dial to begin using your NTC-3000 network connection.



Figure 35 - Connect to Dial-up Prompt

# Communicating with an NTC-3000 Series Modem

## Dumb Terminal

Any terminal emulator can be used to facilitate communication with the NTC-3000 after the Virtual COM port has been installed using either the device's serial port or the USB port. Additionally, you can select to communicate with the modem using your computer's serial port COM port. The example below demonstrates how to use HyperTerminal in Windows XP.

1. Click on the **Start** button and then navigate to the **Accessories** item and then **Communications**.
2. Click on the **HyperTerminal** item.
3. Enter a name for the connection profile (for example: NTC-3000) and click **OK**.
4. On the "Connect to" window, use the "Connect using" dropdown menu to select the virtual COM port (which was created by installing the AirCard Watcher) or the COM port to which the modem is connected if using the DB9 serial/power adapter cable. See the [Verifying successful installation of the driver](#) section to determine the correct port number of the virtual COM port.

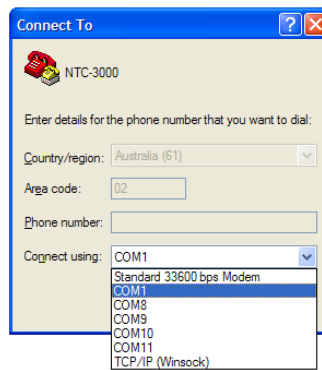

Figure 36 - NTC-3000 Operation Settings - Select COM Port

5. On the COM port settings window that appears, in the **Bits per second** drop down menu, select **115200**.

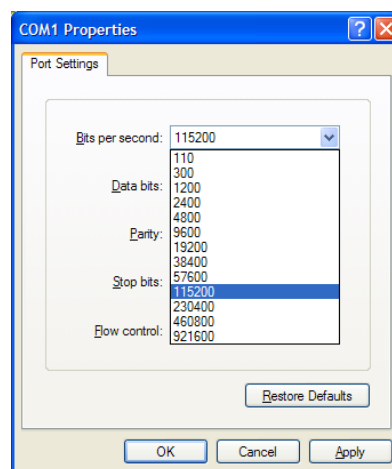
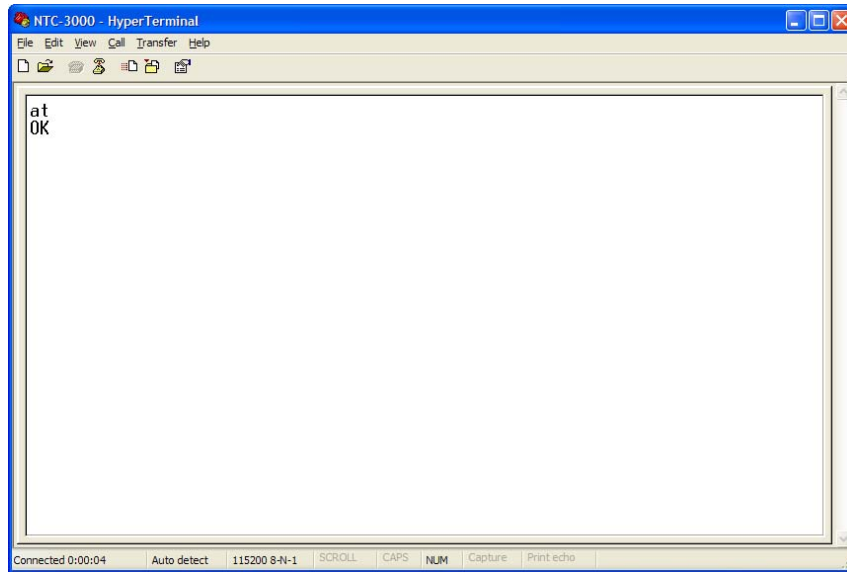

Figure 37 - NTC-3000 Operation Settings - Baud Rate Selection

The terminal window display indicates that a connection is open to the NTC-3000 Series. This can be confirmed by entering the command **at** and receiving the response **OK** as shown below:



Using a terminal emulator such as HyperTerminal and the AT command Reference Guide, the NTC-3000 Series router can be configured to perform customised operations. Please refer to the Supported AT Command Reference Guide available on the NetComm Wireless website at <http://www.sierrawireless.com> for more information on the functions available.

If you are unable to type **at**, check that you have selected the correct COM port for the NTC-3000. Alternatively, try to open a connection using a physical COM port with a DB9 serial/power adapter cable attached.

## Open AT Application Framework

The NetComm Wireless NTC-3000 Series Routers support the Open AT Application Framework. The Open AT application framework consists of an M2M specific operating system, libraries and development studio allowing the accelerated creation of embedded M2M applications and sharing of processing resources.

To begin developing M2M applications, download the Open AT Application Framework on the Sierra Wireless developer website at <http://developer.sierrawireless.com/OpenAT/download>

# NetComm Wireless Open AT Custom Application

The NTC-3000 comes pre-loaded with a NetComm Wireless Open AT custom application. This application allows the NTC-3000 to operate in different modes, providing additional functionality and support for a number of terminal commands specific to this application. These commands can be used locally or by SMS to send or receive serial data to or from TCP/UDP servers (typically another NTC-3000) using GSM/GPRS connections.



Please note: Installing another custom application will cause the NetComm Wireless Open AT custom application to cease functioning as only one custom application may be used at a time.

The NTC-3000 modem has 4 modes available:

NUMBER	MODE	DESCRIPTION
0	Disabled	In this mode, the Serial to TCP gateway function is disabled and the NTC-3000 behaves as a normal modem.
1	TCP Client	This is the default mode. The NTC-3000 transfers TCP data between the serial and IP connections.
2	TCP Server	The NTC-3000 accepts incoming IP connections and transfers data between serial and IP connections.
3	UDP Client	The NTC-3000 transfers UDP data between the serial and IP connections.

## Command List

The following is a complete list of commands for the NetComm Wireless Open AT custom application:

### AT+PAD

Description: Specifies the NTC-3000 operation mode.

Usage 1: To set the operation mode

**AT+PAD=x**

where 'x' is an option number.

Usage 2: To retrieve the currently configured operation mode

**AT+PAD?**

Help: **AT+PAD=?**

Options:

0	disabled
1	tcp client
2	tcp server
3	udp client

Example: To switch the NTC-3000 to TCP client mode, enter

**AT+PAD=1**

## AT+APN

Description: Sets the Access Point Name (APN) used to connect to the broadband network. The default setting is blank.

Usage 1: To set the APN

```
AT+APN=xxxx
```

where 'xxxx' is the APN that you wish to use.

Usage 2: To retrieve the currently configured APN

```
AT+APN?
```

Example: To set the APN to 'testAPN' enter

```
AT+APN=testAPN
```

## AT+USER\_PASS

Description: Sets the username and password used to connect to the broadband network.

Usage 1: To set the username and password

```
AT+USER_PASS="xxxx" , "xxxx"
```

Usage 2: To retrieve the currently configured username and password

```
AT+USER_PASS?
```

Help: AT+USER\_PASS=?

Options: username the user name for the broadband account  
password the password for the broadband account

Example: To configure the username as 'user1' and password as 'testpass' enter

```
AT+USER_PASS="user1" , "testpass"
```

## AT+SERIAL\_BAUD

Description: Sets the baud rate used for communication between the modem and the connected device.

Usage 1: To set the baud rate

```
AT+SERIAL_BAUD=[ baud ]
```

Usage 2: To retrieve the currently configured baud rate

```
AT+SERIAL_BAUD?
```

Help: AT+SERIAL\_BAUD=?

Options: 300, 600, 1200, 2400, 4800, 9600, 19200, 38400, 57600, 115200 (default value), 230400, 460800, 921600.

Example: To configure the baud rate to 115200bps enter

```
AT+SERIAL_BAUD=115200
```





## AT+SERIAL\_FORMAT

Description: Sets the serial format used for communication between the modem and the connected device.

Usage 1: To set the serial format

```
AT+SERIAL_FORMAT=x
```

where 'x' is an option number.

Usage 2: To retrieve the currently configured serial format

```
AT+SERIAL_FORMAT?
```

Help: 

```
AT+SERIAL_FORMAT=?
```

Options:	1	8 data 2 stop
	2	8 data 1 parity 1 stop
	3	8 data 1 stop – default value
	4	7 data 2 stop
	5	7 data 1 parity 1 stop
	6	7 data 1 stop

Example: To set the serial format to 8 data 2 stop enter

```
AT+SERIAL_FORMAT=1
```

## AT+SERIAL\_FLOW

Description: Sets the flow control used for communication between the modem and the connected device.

Usage 1: To set the flow control

```
AT+SERIAL_FLOW=x
```

Where 'x' is an option number.

Usage 2: To retrieve the currently configured flow control setting

```
AT+SERIAL_FLOW?
```

Help: 

```
AT+SERIAL_FLOW=?
```

Options:	0	no flow control, default value
	2	hardware, RTSCTS

Example: To set no flow control enter

```
AT+SERIAL_FLOW=0
```

## AT+SERIAL\_PARITY

Description: Sets the serial parity used for communication between the modem and the connected device.

Usage 1: To set the serial parity

```
AT+SERIAL_PARITY=x
```

where 'x' is an option number.

Usage 2: To retrieve the currently configured serial parity

```
AT+SERIAL_PARITY?
```

Help: **AT+SERIAL\_PARITY=?**

Options:

0	Odd
1	Even
4	No parity, default value

Example: To set no serial parity enter

```
AT+SERIAL_PARITY=4
```

## AT+SERVER

Description: Sets the TCP/UDP server IP address and port or hostname and port. In TCP Client mode this command sets the remote TCP server IP address and remote port number. In TCP Server mode the port number will be used as the local TCP Server port number. In UDP Client mode, this command will set the UDP server IP address and remote port number. If a remote UDP socket wants to send back data, it must use this port number.

Usage 1: To set the server IP address and port

```
AT+SERVER=xxx.xxx.xxx.xxx,yyyyy
```

Where 'xxx.xxx.xxx.xxx' is the server IP address and 'yyyyy' is the port number

Usage 2: To set the server hostname and port

```
AT+SERVER=xxxx,yyyyy
```

Where 'xxxx' is the hostname of the server and 'yyyyy' is the port number. If no port number is specified, the NTC-3000 uses the default port 1516.

Usage 3: To retrieve the currently configured server IP and port

```
AT+SERVER?
```

Help: **AT+SERVER=?**

Options:

ip address	the ip address of the server
hostname	the hostname of the server
port number	the port number of the server

Example 1: To set the IP address of the server to 10.1.193.11 and port to 1516, enter

```
AT+SERVER=10.1.193.11,1516
```

Example 2: To set the hostname of the server to 'testhost.domain.com' and port to 8888, enter

```
AT+SERVER=testhost.domain.com,8888
```

## AT+Save

**Description:** Saves any changes made to the settings using commands in this list. Changes to settings using the commands in this list do not take effect immediately and must be saved to the board's flash memory using this command, followed by a reboot. The exception to this is the AT+PAD command which initiates a save command and reboots the device.

**Usage:** To save settings to the onboard flash memory

```
AT+SAVE=1
```

**Example:** To save settings to the onboard flash memory, enter

```
AT+SAVE=1
```

Then enter

```
AT+CFUN=1
```

to perform a reboot so that the new settings take effect.

## AT+CFUN

**Description:** This is a standard AT command which resets the device.

**Usage:** To reset the device

```
AT+CFUN=1
```

## AT+SMS\_DIAGNOSTICS

**Description:** Sets the status of the SMS Diagnostics feature on the NTC-3000.

**Usage 1:** To set the status of SMS Diagnostics

```
AT+SMS_DIAGNOSTICS=x
```

Where 'x' is an option number.

**Help:** `AT+SMS_DIAGNOSTICS=?`

**Options:**

0	disabled
1	enabled

**Example:** To enable SMS Diagnostics, enter

```
AT+SMS_DIAGNOSTICS=1
```

### AT+SMS\_PASSWORD

Description: Used to define the password used with the SMS Diagnostics feature. The password is limited to 6 characters. The default password is '1234'.

Usage 1: To set the SMS password

```
AT+SMS_PASSWORD=XXXXXX
```

Usage 2: To retrieve the current configured password

```
AT+SMS_PASSWORD?
```

Help: `AT+SMS_PASSWORD=?`

Example: To set the password to '1234', enter

```
AT+SMS_PASSWORD=1234
```

### AT+SMS\_ACK

Description: Sets the status of the SMS acknowledgement feature. When enabled, the NTC-3000 sends a reply SMS to inform whether the command was successful.

Usage 1: To configure SMS acknowledgments

```
AT+SMS_ACK=x
```

Where 'x' is an option number.

Usage 2: To retrieve the SMS acknowledgment status

```
AT+SMS_ACK?
```

Help: `AT+SMS_ACK=?`

Options:

0	disabled
1	enabled

Example: To enable SMS acknowledgements , enter

```
AT+SMS_ACK=1
```

### AT+VERSION

Description: Displays the version number of the NetComm Wireless custom application installed.

Usage: `AT+VERSION?`

## AT+FORCE\_RESET

Description: Sets the period for which the NTC-3000 will automatically reset.

Usage 1: To set the force reset period

```
AT+FORCE_RESET=xxxxx
```

Where 'x' is an integer between 2 and 65535 minutes.

Usage 2: To retrieve the currently configured force reset period

```
AT+FORCE_RESET?
```

Help: `AT+FORCE_RESET=?`

Options: 0 no reset  
2 - 65535 minutes between a forced reset

Example: To set the NTC-3000 to reboot every 60 minutes, enter

```
AT+FORCE_RESET=60
```

## AT+EOL

Description: Send this command to delimit data received from the serial port. The default setting is 0x0D,0x0A.

Usage: `AT+EOL=xx , yy`

where 'xx' is the hexadecimal code for the carriage return character and 'yy' is the hexadecimal code of the line feed character.

Help: `AT+EOL=?`

Example: To configure the carriage return and line feed characters to 'D' and 'A', enter

```
AT+EOL=0x0D , 0x0A
```

## AT+CHAR\_TIMEOUT

Description: By default, data received from the serial interface is buffered for 1\*100ms. This can be changed to a value up to 65535 seconds, expressed as a factor of 100ms. After this delay, data will be sent out regardless of end of line input.

Usage 1: To configure the character timeout

```
AT+CHAR_TIMEOUT=xxx
```

where 'x' is an integer to be multiplied by 100ms between 0 and 255.

Usage 2: To retrieve the currently configured character timeout value

```
AT+CHAR_TIMEOUT?
```

Help: `AT+CHAR_TIMEOUT=?`

Options: 0 disable (always use delimiters instead)  
1 - 255 \* 100ms

Example: To configure the character timeout to 1 second, enter

```
AT+CHAR_TIMEOUT=10
```

## AT+TCP\_TIMEOUT

**Description:** This command sets the TCP timeout value in seconds. If the TCP/IP connection is not working, the application will wait for this period of time to re-establish the connection. The minimum timeout period is 10 seconds while the maximum is 65535 seconds.

**Usage 1:** To configure the TCP timeout value

```
AT+TCP_TIMEOUT=xxxxxx
```

Where 'x' is an integer in seconds between 10 and 65535.

**Usage 2:** To read the currently configured TCP timeout value

```
AT+TCP_TIMEOUT?
```

**Help:** `AT+TCP_TIMEOUT=?`

**Example:** To set the TCP timeout period to 10 seconds

```
AT+TCP_TIMEOUT=10
```

## AT+TCP\_RETRY

**Description:** If the NTC-3000 is operating in TCP or UDP client mode and the connection with the server is down, the application will try for the AT+TCP\_RETRY number of times to re-establish the connection with the server, then it will wait for the specified TCP\_TIMEOUT period and try again. The minimum value is 0 which will cause the NTC-3000 to retry the connection until a connection is made while the maximum value is 10.

**Usage 1:** To set the TCP retry count

```
AT+TCP_RETRY=xx
```

where 'x' is an integer between 0 and 10.

**Usage 2:** To retrieve the currently configured TCP retry count

```
AT+TCP_RETRY?
```

**Help:** `AT+TCP_RETRY=?`

**Options:**

0	Infinite (always try to connect when connection fails)
1 – 10	times to attempt reconnection

## AT+LOCAL\_IP

**Description:** Retrieves the NTC-3000's allocated WAN IP address.

**Usage:** `AT+LOCAL_IP?`

## AT+DNS

**Description:** Retrieves the NTC-3000's allocated DNS address.

**Usage:** `AT+DNS?`



## AT+FACTORY\_RESET

Description: Resets the NTC-3000 to factory default settings, effectively performing the following commands:

```
AT + PAD = 0
AT + APN =
AT + USER_PASS = " ", " "
AT + FORCE_RESET = 0
AT + SERVER = ,1516
AT + SMS_DIAGNOSTICS= 0
AT + SMS_ACK = 0
AT + SMS_PASSWORD = 1234
AT + EOL = 0x0D,0x0A
AT + SERIAL_BAUD = 115200
AT + SERIAL_FORMAT = 3
AT + SERIAL_PARITY = 4
AT + SERIAL_FLOW = 0
AT + CHAR_TIMEOUT = 8 seconds
AT + TCP_TIMEOUT = 10
AT + TCP_RETRY = 0 (Infinite)
AT + DYN_ENABLE = 0
AT + DYN_HOST =
AT + DYN_USER =
AT + DYN_PASS =
```

Usage: **AT+FACTORY\_RESET=1**

Help: **AT+FACTORY\_RESET=?**

## AT+SERIAL\_ON\_START

Description: This command configures whether the serial port initialises on power up or initialises when there are active connections.

Usage: **AT+SERIAL\_ON\_START=x**

where 'x' is an option number

Usage 2: **AT+SERIAL\_ON\_START?**

Help: **AT+SERIAL\_ON\_START=?**

Options: 1 serial port is initialised on power up  
0 serial port is initialised when there are active connections

## AT+DYN\_ENABLE

Description: Instructs the NTC-3000 to enable updating its IP address to the configured Dynamic DNS server.

Usage: `AT+DYN_ENABLE=x`

Where 'x' is an option number

Help: `AT+DYN_ENABLE=?`

Options: 0       disable  
          1       enable

Example: To set the NTC-3000 to enable star updates to the Dynamic IP address table, enter

```
AT+DYN_ENABLE=1
```

## AT+DYN\_HOST

Description: Instructs the NTC-3000 to use the supplied hostname to perform an IP address update.

**Note:** The only dynamic DNS service supported at this time is [www.dyndns.org](http://www.dyndns.org)

Usage: `AT+DYN_HOST=XXXX`

where "XXXX" is the hostname of the dynamic DNS service.

Example: To instruct the NTC-3000 to use 'testuser.dyndns.org' as the dynamic DNS hostname to perform an IP address update, enter

```
AT+DYN_HOST=testuser.dyndns.org
```

## AT+DYN\_USER

Description: Configures the username for the dynamic DNS service.

Usage: `AT+USER=XXX`

Example: To set the dynamic DNS service username to 'testuser', enter

```
AT+USER=testuser
```

## AT+DYN\_PASS

Description: Configures the password for the dynamic DNS service.

Usage: `AT+PASS=XXX`

Example: To set the dynamic DNS service username to 'testpass1', enter

```
AT+USER=testpass1
```

## General Operation

Upon powering up, the application subscribes to the SMS service and sets up customized AT commands. It then reads the configuration from FLASH. If the device is configured in normal modem mode (AT+PAD=0), the application will not start GSM or GPRS initialization, TCP or UDP preparation routines.

When TCP/IP has been set up, an IP address will be issued to the NTC-3000. The application can then switch to one of the following modes:

```
TCP client mode
TCP server mode
UDP client mode
```

The application can switch to any of these modes by AT command or remotely through SMS. The serial port can be initialized while GSM/GPRS registration in progress. If the flash configuration area is empty, the default parameters are loaded. The default parameters are as follows:

### *Serial Port*

```
Baud Rate: 115200
Data Bits: 8
Parity: none
Stop Bit: 1
```

### *PDP profile*

```
APN :
User:
Password:
```

### *TCP Client*

```
Server :
Port: 1516
```

The NTC-3000 default running mode is with PAD disabled.

## Configuration through SMS

The NTC-3000 can be configured through the serial port with AT commands or remotely through SMS messages. When configuring the NTC-3000 using SMS messages, all the messages must be prefixed with a password.

The following is a list of SMS commands that may be used:

1. `get status`
2. `get settings`
3. `get version`
4. `get force_reset`
5. `get serial_on_start`
6. `execute reboot`
7. `execute save`
8. `execute pdpcycle`
9. `execute pdpdown`
10. `execute pdpup`
11. `set apn`
12. `set pdpauth`
13. `set smspassword`
14. `set pad`
15. `set server`
16. `set dyn_enable`
17. `set dyn_host`
18. `set dyn_user`
19. `set dyn_pass`
20. `set serial_on_start`
21. `set force_reset`

### `get status`

The NTC-3000 sends an SMS reply with the following information:

```
IMEI:xxxxxx  
UpTime:xx:xx:xx  
Connection UpTime:xx:xx:xx  
IP:xxx.xxx.xxx.xxx
```

### get settings

The NTC-3000 replies with the following information:

```
APN: testAPN
PDP: testuser@domain.com.au, test
SERVER: 10.1.193.11,1516
PAD: 1
DYN_ENABLE: 1
DYN_HOST: testuser.dyndns.org
DYN_USER: testuser
DYN_PASS: testpass
```

### get version

The NTC-3000 replies with the version of the NetComm Wireless custom application.

### get force\_reset

The NTC-3000 replies with the current FORCE\_RESET period.

### get serial\_on\_start

The NTC-3000 replies with the current SERIAL\_ON\_START flag.

### execute reboot

Instructs the NTC-3000 to perform a reboot immediately.

### execute save

Instructs the NTC-3000 to save the current settings to on-board flash memory.

### execute pdpcycle

Instructs the NTC-3000 to stop the current PDP session and reconnect it.

### execute pdpdown

Instructs the NTC-3000 to stop the active PDP session.

### execute pdpup

Instructs the NTC-3000 to connect the PDP.

### set apn=xxxxxx

Sets the APN used to connect to the PDP session. The new APN will take effect after performing the "execute pdpcycle" command. This new APN won't be saved to on-board flash memory unless the "execute save" command is issued.

### set pdpauth="user name","password"

Sets the username and password used for authentication to the PDP session.

### set smspassword=XXXXXX

Sets the SMS password required as a prefix for all SMS commands. The password may be a maximum of 6 characters in length.

### set pad=0,1,2,3

Sets the NTC-3000 mode of operation where "0" is "PAD disabled mode", "1" is "TCP client mode", "2" is "TCP server mode" and "3" is "UDP client mode".



`set server= ip address/hostname, port`

Sets the server IP address or hostname and port that the NTC-3000 will use when operating in TCP server mode.

`set dyn_enable=0,1`

When this value is set to 1, the NTC-3000 automatically updates the IP address from the dynamic DNS host. When this value is set to 0, the dynamic DNS feature is disabled.

`set dyn_host=xxx`

Sets the Dynamic DNS hostname.

`set dyn_user=xxx`

Sets the Dynamic DNS username.

`set dyn_pass=xxx`

Sets the Dynamic DNS password.

`set serial_on_start=0,1`

When this value is set to 1, the NTC-3000 enables the serial port when the unit boots up. When this value is set to 0, the NTC-3000 will not start the serial port on boot.

`set force_reset=xxxxx`

Sets the FORCE\_RESET period in minutes. Valid intervals are 2 – 65535 minutes. Setting this value to 0 disables the forced reset function.

# Technical Data

The following table lists the hardware specifications of the NTC-3000 Series devices.

MODEL	NETCOMM NTC-3000 SERIES
Modem Chipset/Module	Sierra Wireless AirPrime SL8080T (NTC-3000-01) Sierra Wireless AirPrime SL8082T (NTC-3000-02) Sierra Wireless AirPrime SL8084T (NTC-3000-03)
UMTS bands	UMTS 850/1900 (NTC-3000-01) UMTS 900/2100 (NTC-3000-02) UMTS 850/2100 (NTC-3000-03)
GSM bands	Quad-band EDGE/GPRS/GSM 850/900/1800/1900MHz
Maximum Data Throughput / 3G Radio interface	Peak download rate: 3.6 Mbps Peak upload rate: 384 Kbps
Maximum Data Throughput / Serial RS232 interface	Auto baud rate - 115,200 / 57,600 / 38,400 / 19,200 / 9,600 / 4,800 / 2,400 bps
Connectivity	1x RJ-45 port (incl. DB9 adapter) for serial RS-232 connections 1x Mini USB console port (Windows driver available)
SIM Card Reader	Lockable tray, supports standard USIM/SIM
Antenna connector	1x SMA
LED Indicators	Power, 3G Status
Operating Temperature	Normal: -40 ~ 85 °C
Power input	5 ~ 36 V DC via RJ-45 port
Dimensions & Weight	74 x 57 x 24 mm / 84g (w/o mounting bracket and antenna)
Regulatory Compliancy	A-Tick, CE (NTC-3000-02) A-Tick, CE (NTC-3000-03)

Table 6 - Technical Specifications for the NTC-3000 Series

## Mini USB Connector

The mini USB connector provides a USB based virtual COM port to facilitate communications to the NTC-3000 series in the event that a COM port fails. This is achieved through the use of an SWI driver and an accompanying "3G Watcher" application. The connector uses a standard mini USB pin out configuration.

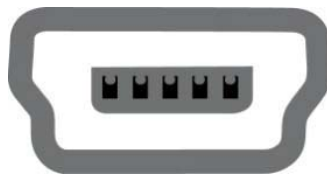

Pin: 1 5

Figure 38 - The Mini USB Connector

PIN	SIGNAL
1	VIN
2	D-
3	D+
4	N/C
5	GND

Table 7 - Mini USB Connector Pin Outs



## RJ-45 Connector

The RJ-45 connector provides an interface for a serial data connection and for device input power using the pin layout shown below.

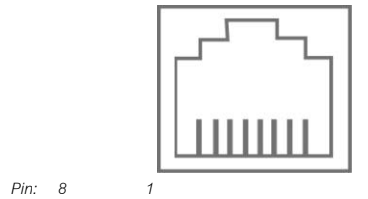

Figure 39 -The RJ-45 Connector

PIN	SIGNAL	DESCRIPTION
1	VCC	Input voltage 5VDC - 36VDC
2	DCD	Data Carrier Detect
3	DTR	Data Terminal Ready
4	GND	Common Ground
5	RXD	Serial Data out
6	TXD	Serial Data in
7	RTS	Request/Ready to Send
8	CTS	Clear to Send

Table 8 - RJ-45 Connector Pin Outs

## RJ-45 to DB9 Serial/Power Adapter Cable

The following table displays the PIN out configuration for the RS-232 serial connection cable that ships with the NTC-3000 series modems.

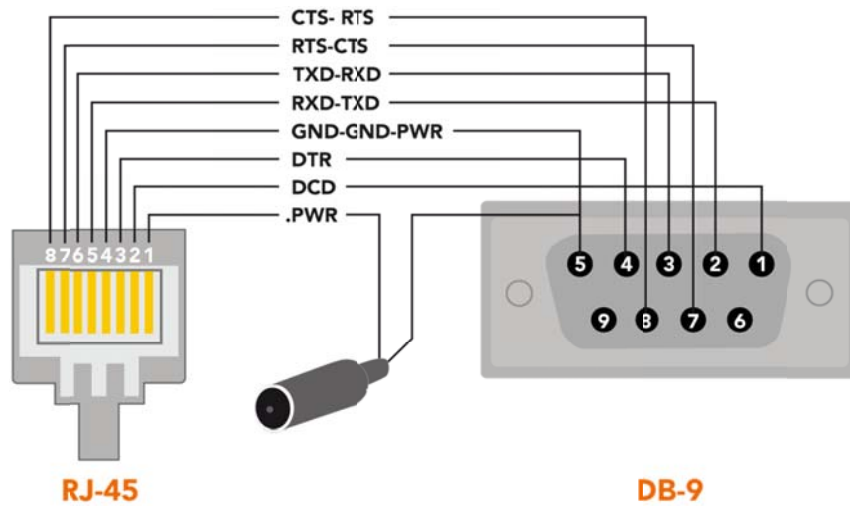

Figure 40 - RJ-45 to DB-9 Serial/Power Adapter Cable

DB9	SIGNAL		RJ45	DESCRIPTION
1	DCD	↔	2	Data Carrier Detect
2	RXD	↔	5	Serial Data Out
3	TXD	↔	6	Serial Data In
4	DTR	↔	3	DTR
5	GND	↔	4	Common Ground GND (Power Ground)
6	DSR	↔	-	Not Used
7	RTS	↔	7	Request to Send (received by the NTC-3000)
8	CTS	↔	8	Clear to Send (transmitted by the NTC-3000)
9	RI	↔	-	Not Used
-	Power	↔	1	Red Wire: VCC (Input voltage from 5V - 36VDC)

*Table 9 - RJ-45 to DB-9 Serial/Power Connector Pin Outs*

The NTC-3000 is a DCE (Data Circuit-Terminating Environment), so the RTS (Ready To Send) signal is received by the NTC-3000 and the CTS (Clear to Send) signal is transmitted with flow controlled from both ends.

The DCD (Data Carrier Detect) line is permanently set to one state, i.e. in the high state at the connector, GND at the chip.

## Electrical Specifications

A suitable power supply is available on request or via direct purchase from the NetComm Online shop. It is recommended that the NTC-3000 be powered using a 12VDC/1.5A power supply.

## Environmental Specifications / Tolerances





The industrial enclosure of the NTC-3000 Series makes it able to operate over a wide variety of temperatures from -20°C ~ 50°C.

# Product Service and Support

The following section provides some assistance with issues that may be encountered when using the NTC-3000 series as well as providing web based links for product specific information.

## Troubleshooting

- 1) I am unable to send any AT commands to the NTC-3000



-  Verify the NTC-3000 is connected to both the power supply and an appropriate COM port.
-  Verify the LEDs on the front of the NTC-3000 are illuminated.
-  Verify your terminal program settings or device is set to use the appropriate COM port.
-  Power cycle the NTC-3000 by removing the power supply for 15 seconds and then reconnect it.

- 2) I only receive garbage text when sending AT commands to the NTC-3000

-  Verify that the COM port parameters have not changed since the NTC-3000 series was initially connected. Garbage text usually indicates that the port speed has been changed.

Please refer to the AT Command reference document for more information on enabling remote access to the NTC-3000 series.

- 3) The NTC-3000 LEDs are not lighting up

-  Verify that the NTC-3000 series is connected to an appropriate power supply and that an active 3G SIM has been inserted.
-  Power cycle the NTC-3000 by removing the power supply for 15 seconds and then reconnect it.

- 4) The 3G LED is not switching on

-  Verify that the NTC-3000 series has sufficient 3G signal strength to connect by checking the available signal strength via either the appropriate AT command or by checking a mobile telephone for available 3G coverage.



Please refer to the AT Command reference document for more information on signal strength.

- 5) I am receiving an 'ERROR' response from the NTC-3000

-  Verify the AT command you are utilising has the correct syntax specified.

- 6) I am receiving an 'ERROR (##)' response from the NTC-3000 with an error code that I don't understand



-  Please refer to the error codes in the AT Command manual which can be found on the Sierra Wireless Website to learn the meaning of the Result codes.

If you are still experiencing issues after performing the above checks, please contact NetComm Technical Support by going to:

<http://support.netcommwireless.com/>

## Web Based Product References









The following reference information is also available for the NTC-3000 Series from the NetComm Support website at <http://www.netcommwireless.com/product/m2m/ntc-3000>

-  User Manual
-  Quick Start Guide
-  Product Specification Sheet

## FAQs

Q: Is the NTC-3000 series a 3G serial modem?

A: The NTC-3000 series is able to operate as a 3G serial modem, however it is also so much more. It is also able to perform the following functions:

-  Creating TCP server
-  Creating UDP sockets / TCP clients and TCP server
-  Creating a PING session
-  Creating a FTP session (upload and download files)
-  Connect to remote SMTP server
-  Connect to remote HTTP server
-  Email sending / receiving
-  Sending an MMS with one or multiple recipients

These functions are supported in Sierra Wireless's WIPSOFT. Refer to the [Sierra Wireless Developer Zone](#) to obtain the latest version of the devkit to perform these functions.

Q: What are the port settings required for the NTC-3000 Series?

A: The NTC-3000 series uses auto-bauding to determine the current communication port settings. This occurs when the first A or AT is sent to the NTC-3000 series. Generally, a port speed of 115200, 8 data bits, 1 stop bit, no parity and hardware flow control should be fine.

Q: Does the NTC-3000 Series support circuit and packet switched data?

A: The modem inside the NTC-3000 series supports only Packet Switched communications methods.

Q: Can the mini USB port be used to connect to legacy devices?

A: No. The mini USB port requires Windows XP SP3, Windows Vista SP2, Windows 7 SP1 or higher or Mac OS 10.5.8 or higher to install and use.

Q: Why can't I connect an Ethernet (RJ-45) cable to the NTC-3000 Series?

A: The NTC-3000 series uses a serial connection through a modified RJ-45 port utilising some pins from this to provide power. It is not suitable for an Ethernet connection.



Please refer to the [RJ-45 port](#) pin out diagram in the [Technical Data](#) chapter for more information.

# Appendix A: Tables

Table 1 - Document Revision History.....	3
Table 2 - LED Indicators .....	8
Table 3 - Device Dimensions .....	8
Table 4 - Mounting Bracket Dimensions.....	8
Table 5 - Integrated Devices.....	9
Table 6 - Technical Specifications for the NTC-3000 Series.....	48
Table 7 - Mini USB Connector Pin Outs.....	48
Table 8 - RJ-45 Connector Pin Outs .....	49
Table 9 - RJ-45 to DB-9 Serial/Power Connector Pin Outs.....	50

# Safety and product care

## RF Exposure

Your device contains a transmitter and a receiver. When it is on, it receives and transmits RF energy. When you communicate with your device, the system handling your connection controls the power level at which your device transmits.

This device meets the government's requirements for exposure to radio waves.

This device is designed and manufactured not to exceed the emission limits for exposure to radio frequency (RF) energy set by the Federal Communications Commission of the U.S. Government.

This equipment complies with radio frequency (RF) exposure limits adopted by the Federal Communications Commission for an uncontrolled environment. This equipment should be installed and operated with minimum distance 20 cm between the radiator & your body.

## External antenna

Any optional external antenna used for this transmitter must be installed to provide a separation distance of at least 20 cm from all persons and must not be co-located or operated in conjunction with any other antenna or transmitter. Please consult the health and safety guide of the chosen antenna for specific body separation guidelines as a greater distance of separation may be required for high-gain antennas.

Any external antenna gain must meet RF exposure and maximum radiated output power limits of the applicable rule section. The maximum antenna gain for this device as reported to the FCC is: 1dBi(850MHz) and 1dBi(1900MHz).

## FCC Statement





### FCC compliance

Federal Communications Commission Notice (United States): Before a wireless device model is available for sale to the public, it must be tested and certified to the FCC that it does not exceed the limit established by the government-adopted requirement for safe exposure.

### FCC regulations

This device complies with part 15 of the FCC Rules. Operation is subject to the following two conditions: (1) This device may not cause harmful interference, and (2) this device must accept any interference received, including interference that may cause undesired operation.

This device has been tested and found to comply with the limits for a Class B digital device, pursuant to Part 15 of the FCC Rules. These limits are designed to provide reasonable protection against harmful interference in a residential installation. This equipment generates, uses and can radiate radio frequency energy and, if not installed and used in accordance with the instructions, may cause harmful interference to radio communications. However, there is no guarantee that interference will not occur in a particular installation. If this equipment does cause harmful interference to radio or television reception, which can be determined by turning the equipment off and on, the user is encouraged to try to correct the interference by one or more of the following measures:

-  Reorientate or relocate the receiving antenna.
-  Increase the separation between the equipment and receiver.
-  Connect the equipment into an outlet on a circuit different from that to which the receiver is connected.
-  Consult the dealer or an experienced radio/TV technician for help.

Changes or modifications not expressly approved by the party responsible for compliance could void the user's authority to operate the equipment.

## IC regulations

This device complies with Industry Canada licence-exempt RSS standard(s). Operation is subject to the following two conditions:

- (1) this device may not cause interference, and
- (2) this device must accept any interference, including interference that may cause undesired operation of the device.

Le présent appareil est conforme aux CNR d'Industrie Canada applicables aux appareils radio exempts de licence. L'exploitation est autorisée aux deux conditions suivantes:

- (1) l'appareil ne doit pas produire de brouillage, et
- (2) l'utilisateur de l'appareil doit accepter tout brouillage radioélectrique subi, même si le brouillage est susceptible d'en compromettre le fonctionnement."

This Class B digital apparatus complies with Canadian CAN ICES-3 (B)/NMB-3(B).

Cet appareil numérique de la classe B est conforme à la norme NMB-003 du Canada.

## IMPORTANT NOTE:

IC radiation exposure statement:

This equipment complies with IC RSS-102 radiation exposure limits set forth for an uncontrolled environment. This equipment should be installed and operated with minimum distance 20cm between the radiator and users body.

## Electrical safety

### Accessories

Only use approved accessories.

Do not connect with incompatible products or accessories.

### Connection to a car

Seek professional advice when connecting a device interface to the vehicle electrical system.

## Distraction

### Operating machinery

Full attention must be given to operating the machinery in order to reduce the risk of an accident.

## Product handling

You alone are responsible for how you use your device and any consequences of its use.

You must always switch off your device wherever the use of a mobile phone is prohibited. Do not use the device without the clip-on covers attached, and do not remove or change the covers while using the device. Use of your device is subject to safety measures designed to protect users and their environment.

Always treat your device and its accessories with care and keep it in a clean and dust-free place.

Do not expose your device or its accessories to open flames or lit tobacco products.

Do not expose your device or its accessories to liquid, moisture or high humidity.

Do not drop, throw or try to bend your device or its accessories.

Do not use harsh chemicals, cleaning solvents, or aerosols to clean the device or its accessories.

Do not paint your device or its accessories.

Do not attempt to disassemble your device or its accessories, only authorised personnel must do so.

Do not use or install this product in extremely hot or cold areas. Ensure that the device is installed in an area where the temperature is within the supported operating temperature range (-20°C to 70°C)

Do not use your device in an enclosed environment or where heat dissipation is poor. Prolonged use in such space may cause excessive heat and raise ambient temperature, which will lead to automatic shutdown of your device or the disconnection of the mobile network connection for your safety. To use your device normally again after such shutdown, cool it in a well-ventilated place before turning it on.

Please check local regulations for disposal of electronic products.

Do not operate the device where ventilation is restricted

Installation and configuration should be performed by trained personnel only.

Do not use or install this product near water to avoid fire or shock hazard. Avoid exposing the equipment to rain or damp areas.

Arrange power and Ethernet cables in a manner such that they are not likely to be stepped on or have items placed on them.

Ensure that the voltage and rated current of the power source match the requirements of the device. Do not connect the device to an inappropriate power source.

## Small children

Do not leave your device and its accessories within the reach of small children or allow them to play with it.

They could hurt themselves or others, or could accidentally damage the device.

Your device contains small parts with sharp edges that may cause an injury or which could become detached and create a choking hazard.

## Emergency situations

This device, like any wireless device, operates using radio signals, which cannot guarantee connection in all conditions. Therefore, you must never rely solely on any wireless device for emergency communications.

## Device heating

Your device may become warm during normal use.

## Faulty and damaged products

Do not attempt to disassemble the device or its accessories.

Only qualified personnel must service or repair the device or its accessories.

If your device or its accessories have been submerged in water punctured or subjected to a severe fall, do not use until they have been checked at an authorised service centre.

## Interference

Care must be taken when using the device in close proximity to personal medical devices, such as pacemakers and hearing aids.

### Pacemakers

Pacemaker manufacturers recommend that a minimum separation of 15cm be maintained between a device and a pacemaker to avoid potential interference with the pacemaker.



### Hearing aids

People with hearing aids or other cochlear implants may experience interfering noises when using wireless devices or when one is nearby.

The level of interference will depend on the type of hearing device and the distance from the interference source, increasing the separation between them may reduce the interference.

You may also consult your hearing aid manufacturer to discuss alternatives.

### Medical devices

Please consult your doctor and the device manufacturer to determine if operation of your device may interfere with the operation of your medical device.

### Hospitals

Switch off your wireless device when requested to do so in hospitals, clinics or health care facilities. These requests are designed to prevent possible interference with sensitive medical equipment.

### Interference in cars

Please note that because of possible interference to electronic equipment, some vehicle manufacturers forbid the use of devices in their vehicles unless an external antenna is included in the installation.

## Explosive environments

### Petrol stations and explosive atmospheres

In locations with potentially explosive atmospheres, obey all posted signs to turn off wireless devices such as your device or other radio equipment.

Areas with potentially explosive atmospheres include fuelling areas, below decks on boats, fuel or chemical transfer or storage facilities, areas where the air contains chemicals or particles, such as grain, dust, or metal powders.

### Blasting caps and areas

Turn off your device or wireless device when in a blasting area or in areas posted turn off "two-way radios" or "electronic devices" to avoid interfering with blasting operations.

# Legal and Regulatory

## Intellectual Property Rights

All intellectual property rights (including copyright and trade mark rights) subsisting in, relating to or arising out of this Manual are owned by and vested in NetComm Wireless Limited (ACN 002490486) (NetComm Wireless Limited) (or its licensors). This Manual does not transfer any right, title or interest in NetComm Wireless Limited's (or its licensors') intellectual property rights to you.

You are permitted to use this Manual for the sole purpose of using the NetComm Wireless product to which it relates. Otherwise no part of this Manual may be reproduced, stored in a retrieval system or transmitted in any form, by any means, be it electronic, mechanical, recording or otherwise, without the prior written permission of NetComm Wireless Limited.

NetComm and NetComm Wireless is a trademark of NetComm Wireless Limited. All other trademarks are acknowledged to be the property of their respective owners.

## Customer Information

The Australian Communications & Media Authority (ACMA) requires you to be aware of the following information and warnings:

1. This unit shall be connected to the Telecommunication Network through a line cord which meets the requirements of the AS/CA S008-2011 Standard.
2. This equipment has been tested and found to comply with the Standards for C-Tick and or A-Tick as set by the ACMA. These standards are designed to provide reasonable protection against harmful interference in a residential installation. This equipment generates, uses, and can radiate radio noise and, if not installed and used in accordance with the instructions detailed within this manual, may cause interference to radio communications. However, there is no guarantee that interference will not occur with the installation of this product in your home or office. If this equipment does cause some degree of interference to radio or television reception, which can be determined by turning the equipment off and on, we encourage the user to try to correct the interference by one or more of the following measures:
  - a) Change the direction or relocate the receiving antenna.
  - b) Increase the separation between this equipment and the receiver.
  - c) Connect the equipment to an alternate power outlet on a different power circuit from that to which the receiver/TV is connected.
  - d) Consult an experienced radio/TV technician for help.
3. The power supply that is provided with this unit is only intended for use with this product. Do not use this power supply with any other product or do not use any other power supply that is not approved for use with this product by NetComm Wireless Limited. Failure to do so may cause damage to this product, fire or result in personal injury.

## Consumer Protection Laws

Australian and New Zealand consumer law in certain circumstances implies mandatory guarantees, conditions and warranties which cannot be excluded by NetComm Wireless Limited and legislation of another country's Government may have a similar effect (together these are the Consumer Protection Laws). Any warranty or representation provided by NetComm Wireless Limited is in addition to, and not in replacement of, your rights under such Consumer Protection Laws.

If you purchased our goods in Australia and you are a consumer, you are entitled to a replacement or refund for a major failure and for compensation for any other reasonably foreseeable loss or damage. You are also entitled to have the goods repaired or replaced if the goods fail to be of acceptable quality and the failure does not amount to a major failure.

If you purchased our goods in New Zealand and are a consumer you will also be entitled to similar statutory guarantees.

## Product Warranty

All NetComm Wireless products have a standard two (2) year warranty from date of purchase (Product Warranty). For all Product Warranty claims you will require proof of purchase. All Product Warranties are in addition to your rights and remedies under applicable Consumer Protection Laws which cannot be excluded (see Section 3 above).

Subject to your rights and remedies under applicable Consumer Protection Laws which cannot be excluded (see Section 3 above), the Product Warranty is granted on the following conditions:

1. The Product Warranty extends to the original purchaser (you / the customer) and is not transferable;
2. The Product Warranty shall not apply to software programs, batteries, power supplies, cables or other accessories supplied in or with the product;
3. The customer complies with all of the terms of any relevant agreement with NetComm Wireless Limited and any other reasonable requirements of NetComm Wireless Limited including producing such evidence of purchase as NetComm may require;
4. The cost of transporting product to and from NetComm Wireless Limited's nominated premises is your responsibility;
5. NetComm Wireless Limited does not have any liability or responsibility under the Product Warranty where any cost, loss, injury or damage of any kind, whether direct, indirect, consequential, incidental or otherwise arises out of events beyond NetComm Wireless Limited's reasonable control. This includes but is not limited to: acts of God, war, riot, embargoes, acts of civil or military authorities, fire, floods, electricity outages, lightning, power surges, or shortages of materials or labour; and
6. The customer is responsible for the security of their computer and network at all times. Security features may be disabled within the factory default settings. NetComm Wireless Limited recommends that you enable these features to enhance your security.

Subject to your rights and remedies under applicable Consumer Protection Laws which cannot be excluded (see Section 3 above), the Product Warranty is automatically voided if:

1. You, or someone else, use the product, or attempt to use it, other than as specified by NetComm Wireless Limited;
2. The fault or defect in your product is the result of a voltage surge subjected to the product either by the way of power supply or communication line, whether caused by thunderstorm activity or any other cause(s);
3. The fault is the result of accidental damage or damage in transit, including but not limited to liquid spillage;
4. Your product has been used for any purposes other than that for which it is sold, or in any way other than in strict accordance with the user manual supplied;
5. Your product has been repaired or modified or attempted to be repaired or modified, other than by a qualified person at a service centre authorised by NetComm Wireless Limited; or
6. The serial number has been defaced or altered in any way or if the serial number plate has been removed.

## Limitation of Liability

This clause does not apply to New Zealand consumers. Subject to your rights and remedies under applicable Consumer Protection Laws which cannot be excluded (see Section 3 above), NetComm Wireless Limited accepts no liability or responsibility, for consequences arising from the use of this product. NetComm Wireless Limited reserves the right to change the specifications and operating details of this product without notice.

If any law implies a guarantee, condition or warranty in respect of goods or services supplied, and NetComm Wireless Limited's liability for breach of that condition or warranty may not be excluded but may be limited, then subject to your rights and remedies under any applicable Consumer Protection Laws which cannot be excluded, NetComm Wireless Limited's liability for any breach of that guarantee, condition or warranty is limited to:

- (i) in the case of a supply of goods, NetComm Wireless Limited doing any one or more of the following: replacing the goods or supplying equivalent goods; repairing the goods; paying the cost of replacing the goods or of acquiring equivalent goods; or paying the cost of having the goods repaired; or
- (ii) in the case of a supply of services, NetComm Wireless Limited doing either or both of the following: supplying the services again; or paying the cost of having the services supplied again.

To the extent NetComm is unable to limit its liability as set out above, NetComm Wireless Limited limits its liability to the extent such liability is lawfully able to be limited.

## Contact

Address: NETCOMM WIRELESS LIMITED, Level 2, 18-20 Orion Road, Lane Cove NSW 2066 Sydney, Australia

ABN: 85 002 490 486

Website: <http://www.netcommwireless.com/>

Phone: +61(0)2 9424 2070

Fax: +61(0)2 9424 2010

Email: [sales@netcommwireless.com](mailto:sales@netcommwireless.com), [technicalsupport@netcommwireless.com](mailto:technicalsupport@netcommwireless.com)