

NETGEAR Wireless N150 Access Point WN604 Reference Manual



NETGEAR®

NETGEAR, Inc.
350 E. Plumeria Dr.
San Jose, CA 95134 USA

202-10623-01
March 2010

© 2010 by NETGEAR, Inc. All rights reserved..

Technical Support

Please refer to the support information card that shipped with your product. By registering your product at <http://www.netgear.com/register>, we can provide you with faster expert technical support and timely notices of product and software upgrades.

NETGEAR, INC. Support Information

Phone: 1-888-NETGEAR, for US & Canada only. For other countries, see your Support information card.

E-mail: support@netgear.com

North American NETGEAR website: <http://www.netgear.com>

Trademarks

NETGEAR, the NETGEAR logo, ProSafe, and Auto Uplink are trademarks or registered trademarks of NETGEAR, Inc. Microsoft, Windows, Windows NT and Vista are registered trademarks of Microsoft Corporation. Other brand and product names are registered trademarks or trademarks of their respective holders.

Statement of Conditions

In the interest of improving internal design, operational function, and/or reliability, NETGEAR reserves the right to make changes to the products described in this document without notice.

NETGEAR does not assume any liability that may occur due to the use or application of the product(s) or circuit layout(s) described herein.

Certificate of the Manufacturer/Importer

It is hereby certified that the NETGEAR Wireless N150 Access Point WN604 has been suppressed in accordance with the conditions set out in the BMPT-AmtsblVfg 243/1991 and Vfg 46/1992. The operation of some equipment (for example, test transmitters) in accordance with the regulations may, however, be subject to certain restrictions. Please refer to the notes in the operating instructions.

The Federal Office for Telecommunications Approvals has been notified of the placing of this equipment on the market and has been granted the right to test the series for compliance with the regulations.

Bestätigung des Herstellers/Importeurs

Es wird hiermit bestätigt, daß das NETGEAR Wireless N150 Access Point WN604 gemäß der im BMPT-AmtsblVfg 243/1991 und Vfg 46/1992 aufgeführten Bestimmungen entstört ist. Das vorschriftsmäßige Betreiben einiger Geräte (z.B. Testsender) kann jedoch gewissen Beschränkungen unterliegen. Lesen Sie dazu bitte die Anmerkungen in der Betriebsanleitung.

Das Bundesamt für Zulassungen in der Telekommunikation wurde davon unterrichtet, daß dieses Gerät auf den Markt gebracht wurde und es ist berechtigt, die Serie auf die Erfüllung der Vorschriften hin zu überprüfen.

Voluntary Control Council for Interference (VCCI) Statement

This equipment is in the Class B category (information equipment to be used in a residential area or an adjacent area thereto) and conforms to the standards set by the Voluntary Control Council for Interference by Data Processing Equipment and Electronic Office Machines aimed at preventing radio interference in such residential areas. When used near a radio or TV receiver, it may become the cause of radio interference. Read instructions for correct handling.



Note: Delete this note and the information below for products that are not wireless.

Regulatory Compliance Information

This section includes user requirements for operating this product in accordance with National laws for usage of radio spectrum and operation of radio devices. Failure of the end-user to comply with the applicable requirements may result in unlawful operation and adverse action against the end-user by the applicable National regulatory authority.

NOTE: This product's firmware limits operation to only the channels allowed in a particular Region or Country. Therefore, all options described in this user's guide may not be available in your version of the product.

Europe – EU Declaration of Conformity



Marking by the above symbol indicates compliance with the Essential Requirements of the R&TTE Directive of the European Union (1999/5/EC). This equipment meets the following conformance standards:

EN300 328, EN301 489-17, EN60950

Europe – Declaration of Conformity in Languages of the European Community

Cesky [Czech]	<i>NETGEAR Inc.</i> tímto prohlašuje, že tento Radiolan je ve shodě se základními požadavky a dalšími příslušnými ustanoveními směrnice 1999/5/ES..
Dansk [Danish]	Undertegnede <i>NETGEAR Inc.</i> erklærer herved, at følgende udstyr Radiolan overholder de væsentlige krav og øvrige relevante krav i direktiv 1999/5/EF.
Deutsch [German]	Hiermit erkläre <i>NETGEAR Inc.</i> , dass sich das Gerät Radiolan in Übereinstimmung mit den grundlegenden Anforderungen und den übrigen einschlägigen Bestimmungen der Richtlinie 1999/5/EG befindet.
Eesti [Estonian]	Käesolevaga kinnitab <i>NETGEAR Inc.</i> seadme Radiolan vastavust direktiivi 1999/5/EÜ põhinõuetele ja nimetatud direktiivist tulenevatele teistele asjakohastele sätetele.
English	Hereby, <i>NETGEAR Inc.</i> , declares that this Radiolan is in compliance with the essential requirements and other relevant provisions of Directive 1999/5/EC.
Español [Spanish]	Por medio de la presente <i>NETGEAR Inc.</i> declara que el Radiolan cumple con los requisitos esenciales y cualesquiera otras disposiciones aplicables o exigibles de la Directiva 1999/5/CE.
Ἄεεçiéêþ [Greek]	Ἰὰ ὀçí ḂÁÑĬŌÁ <i>NETGEAR Inc.</i> ἈçÈÙíÁÉ ἰŌÉ Radiolan ÓŌĭĭÑŌÙíĀŌÁÉ ḂÑĬŌ ŌÉŌ ἰŌŌÉÙĀÁÉŌ ἈḂÁÉŌçŌÁÉŌ ḂÁÉ ŌÉŌ ḂĬÉḂḂÁŌ Ó×ĀŌÉÉÁŌ ἈÉÁŌÁĬÁÉŌ ὀçŌ ἰĀçÁÉÁŌ 1999/5/ĀÉ.

Français [French]	Par la présente <i>NETGEAR Inc.</i> déclare que l'appareil Radiolan est conforme aux exigences essentielles et aux autres dispositions pertinentes de la directive 1999/5/CE.
Italiano [Italian]	Con la presente <i>NETGEAR Inc.</i> dichiara che questo Radiolan è conforme ai requisiti essenziali ed alle altre disposizioni pertinenti stabilite dalla direttiva 1999/5/CE.
Latviski [Latvian]	Ar šo <i>NETGEAR Inc.</i> deklarç, ka Radiolan atbilst Direktīvas 1999/5/EK būtiskajām prasībām un citiem ar to saistītajiem noteikumiem.
Lietuviø [Lithuanian]	Šiuo <i>NETGEAR Inc.</i> deklaruoja, kad šis Radiolan atitinka esminius reikalavimus ir kitas 1999/5/EB Direktyvos nuostatas.
Nederlands [Dutch]	Hierbij verklaart <i>NETGEAR Inc.</i> dat het toestel Radiolan in overeenstemming is met de essentiële eisen en de andere relevante bepalingen van richtlijn 1999/5/EG.
Malti [Maltese]	Hawnhekk, <i>NETGEAR Inc.</i> , jiddikjara li dan Radiolan jikkonforma mal-htigijiet essenzjali u ma provvedimenti oħrajn rilevanti li hemm fid-Dirrettiva 1999/5/EC.
Magyar [Hungarian]	Alulírott, <i>NETGEAR Inc.</i> nyilatkozom, hogy a Radiolan megfelel a vonatkozó alapvető követelményeknek és az 1999/5/EC irányelv egyéb előírásainak.
Polski [Polish]	Niniejszym <i>NETGEAR Inc.</i> oświadczam, że Radiolan jest zgodny z zasadniczymi wymogami oraz pozosta³ymi stosownymi postanowieniami Dyrektywy 1999/5/EC.
Português [Portuguese]	<i>NETGEAR Inc.</i> declara que este Radiolan está conforme com os requisitos essenciais e outras disposições da Directiva 1999/5/CE.
Slovensko [Slovenian]	<i>NETGEAR Inc.</i> izjavlja, da je ta Radiolan v skladu z bistvenimi zahtevami in ostalimi relevantnimi določili direktive 1999/5/ES.
Slovensky [Slovak]	<i>NETGEAR Inc.</i> týmto vyhlasuje, že Radiolan spáda základné požiadavky a všetky príslušné ustanovenia Smernice 1999/5/ES.
Suomi [Finnish]	<i>NETGEAR Inc.</i> vakuuttaa täten että Radiolan tyyppinen laite on direktiivin 1999/5/EY oleellisten vaatimusten ja sitä koskevien direktiivin muiden ehtojen mukainen.
Svenska [Swedish]	Härmed intygar <i>NETGEAR Inc.</i> att denna Radiolan står i överensstämmelse med de väsentliga egenskapskrav och övriga relevanta bestämmelser som framgår av direktiv 1999/5/EG.
Íslenska [Icelandic]	Hér með lýsir <i>NETGEAR Inc.</i> yfir því að Radiolan er í samræmi við grunnkröfur og aðrar kröfur, sem gerðar eru í tilskipun 1999/5/EC.
Norsk [Norwegian]	<i>NETGEAR Inc.</i> erklærer herved at utstyret <i>Radiolan</i> er i samsvar med de grunnleggende krav og øvrige relevante krav i direktiv 1999/5/EF.

FCC Requirements for Operation in the United States

FCC Information to User

This product does not contain any user serviceable components and is to be used with approved antennas only. Any product changes or modifications will invalidate all applicable regulatory certifications and approvals

FCC Guidelines for Human Exposure

This equipment complies with FCC radiation exposure limits set forth for an uncontrolled environment. This equipment should be installed and operated with minimum distance of 20 cm between the radiator and your body.

This transmitter must not be co-located or operating in conjunction with any other antenna or transmitter.

FCC Declaration Of Conformity

We NETGEAR, Inc., 4500 Great America Parkway, Santa Clara, CA 95054, declare under our sole responsibility that the model WN604 NETGEAR Wireless N150 Access Point WN604 complies with Part 15 of FCC Rules. Operation is subject to the following two conditions:

- This device may not cause harmful interference, and
- This device must accept any interference received, including interference that may cause undesired operation.

FCC Radio Frequency Interference Warnings & Instructions

This equipment has been tested and found to comply with the limits for a Class B digital device, pursuant to Part 15 of the FCC Rules. These limits are designed to provide reasonable protection against harmful interference in a residential installation. This equipment uses and can radiate radio frequency energy and, if not installed and used in accordance with the instructions, may cause harmful interference to radio communications. However, there is no guarantee that interference will not occur in a particular installation. If this equipment does cause harmful interference to radio or television reception, which can be determined by turning the equipment off and on, the user is encouraged to try to correct the interference by one or more of the following methods:

- Reorient or relocate the receiving antenna
- Increase the separation between the equipment and the receiver
- Connect the equipment into an electrical outlet on a circuit different from that which the radio receiver is connected
- Consult the dealer or an experienced radio/TV technician for help.

NETGEAR Wireless N150 Access Point WN604



Tested to Comply
with FCC Standards
FOR HOME OR OFFICE USE
PY309300122

Modifications made to the product, unless expressly approved by NETGEAR, Inc., could void the user's right to operate the equipment.

Canadian Department of Communications Radio Interference Regulations

This digital apparatus (NETGEAR Wireless N150 Access Point WN604) does not exceed the Class B limits for radio-noise emissions from digital apparatus as set out in the Radio Interference Regulations of the Canadian Department of Communications.

Canada ID: 4054A-09300122

Industry Canada statement:

This device complies with RSS-210 of the Industry Canada Rules. Operation is subject to the following two conditions:

(1) This device may not cause harmful interference, and (2) this device must accept any interference received, including interference that may cause undesired operation.

IMPORTANT NOTE: Radiation Exposure Statement:

This equipment complies with IC radiation exposure limits set forth for an uncontrolled environment. This equipment should be installed and operated with minimum distance 20cm between the radiator & your body.

Product and Publication Details

Model Number:	WN604
Publication Date:	March 2010
Product Family:	Wireless Access Point
Product Name:	NETGEAR Wireless N150 Access Point WN604
Home or Business Product:	Business
Language:	English
Publication Part Number:	202-10623-01
Publication Version Number:	1.0

Contents

About This Manual

- Conventions, Formats, and Scope xi
- How to Print This Manualxii
- Revision Historyxiii

Chapter 1

Introduction

- About the NETGEAR Wireless N150 Access Point WN604 1-1
- Key Features and Standards 1-1
 - Supported Standards and Conventions 1-2
 - Key Features 1-2
 - 802.11b/g/n Standards-based Wireless Networking 1-3
 - Autosensing Ethernet Connections with Auto Uplink 1-4
- Compatible and Related NETGEAR Products 1-4
- System Requirements 1-5
- What's In the Box? 1-5
- Hardware Description 1-5
 - Front Panel 1-6
 - Rear Panel 1-8
 - Side Panel 1-9

Chapter 2

Basic Installation and Configuration

- Wireless Equipment Placement and Range Guidelines 2-2
- Understanding WN604 Wireless Security Options 2-2
 - Wi-Fi Protected Setup 2-3
- Installing the WN604 Wireless Access Point 2-3
 - Setting up the WN604 Wireless Access Point 2-4
 - Configuring LAN and Wireless Access 2-4

Configuring Time Settings	2-7
Configuring Wireless Access	2-9
Deploying the WN604 Wireless Access Point	2-9
Verifying Wireless Connectivity	2-10
Logging In Using the Default IP Address	2-11
Setting Basic IP Options	2-12
Wireless Settings	2-13
Configuring 802.11b/bg/ng Wireless Settings	2-13
Configuring Basic QoS Settings	2-17
Setting Up and Testing Basic Wireless Connectivity	2-18

Chapter 3

Understanding Security Profiles	3-2
Wi-Fi Protected Setup (WPS)	3-5
Configuring a client using WPS	3-5
Configuring Security Manually	3-8
SSID and WEP/WPA Settings Setup Form	3-8
Configuring the RADIUS Server Settings	3-9
Setting up a Security Profile	3-11
Configuring WEP	3-12
Configuring WPA with RADIUS	3-14
Configuring WPA2 with RADIUS	3-16
Configuring WPA and WPA2 with RADIUS	3-17
Configuring WPA-PSK	3-19
Configuring WPA2-PSK	3-20
Configuring WPA-PSK and WPA2-PSK	3-20
Restricting Wireless Access by MAC Address	3-22

Chapter 4

Management

Upgrading the Wireless Access Point Software	4-1
Configuration File Management	4-3
Saving Your Configuration Settings	4-3
Restoring Saved Settings	4-4
Restoring the WN604 to the Factory Default Settings	4-4
Changing the Administrator Password	4-6
Enabling the SysLog Server	4-7

Using Activity Log Information	4-8
Viewing General Summary Information	4-8
Viewing Network Traffic Statistics	4-10
Viewing Available Wireless Station Statistics	4-12

Chapter 5

Advanced Configuration

Configuring Scheduled Wireless	5-1
Configuring Advanced Wireless Settings	5-2
Configuring 802.11b/bg/ng Advanced Wireless Settings	5-3
Configuring Advanced QoS Settings	5-4
Enabling Wireless Bridging	5-6
Configuring a WN604 as a Point-to-Point Bridge	5-9
Configuring a Point-to-Multi-Point Wireless Bridge	5-10

Chapter 6

Troubleshooting and Debugging

No lights are lit on the wireless access point.	6-1
The Wireless LAN activity light does not light up.	6-2
The LAN light is not lit.	6-2
I cannot access the Internet or the LAN with a wireless capable computer.	6-2
I cannot connect to the WN604 to configure it.	6-3
When I enter a URL or IP address I get a timeout error.	6-3
Using the Reset Button to Restore Factory Default Settings	6-4

Appendix A

Default Settings and Technical Specifications

Factory Default Settings	A-1
Technical Specifications	A-3

Appendix B

Related Documents

Index

About This Manual

The *NETGEAR® Wireless N150 Access Point WN604 Reference Manual* describes how to install, configure and troubleshoot the NETGEAR Wireless N150 Access Point WN604. The information in this manual is intended for readers with intermediate computer and Internet skills.

Conventions, Formats, and Scope

The conventions, formats, and scope of this manual are described in the following paragraphs:

- **Typographical Conventions.** This manual uses the following typographical conventions::

<i>Italic</i>	Emphasis, books, CDs, file and server names, extensions
Bold	User input, IP addresses, GUI screen text
Fixed	Command prompt, code
<i>italic</i>	URL links

- **Formats.** This manual uses the following formats to highlight special messages:

	Note: This format is used to highlight information of importance or special interest.
-------------------------------------------------------------------------------------	----------------------------------------------------------------------------------------------



Tip: This format is used to highlight a procedure that will save time or resources.



Warning: Ignoring this type of note may result in a malfunction or damage to the equipment.



Danger: This is a safety warning. Failure to take heed of this notice may result in personal injury or death.

- **Scope.** This manual is written for the WN604 Wireless Access Point according to these specifications:

Product Version	NETGEAR Wireless N150 Access Point WN604
Manual Publication Date	March 2010

For more information about network, Internet, firewall, and VPN technologies, see the links to the NETGEAR website in [Appendix B, “Related Documents.”](#)



Note: Product updates are available on the NETGEAR, Inc. website at <http://kbserver.netgear.com/products/WN604.asp>.

How to Print This Manual

Your computer must have the free Adobe Acrobat reader installed in order to view and print PDF files. The Acrobat reader is available on the Adobe Web site at <http://www.adobe.com>.

- **Printing a PDF chapter.** Use the **PDF of This Chapter** link at the top left corner of any page.
 - Click the **PDF of This Chapter** link at the top left corner of any page in the chapter you want to print. The PDF version of the chapter you were viewing opens in a browser window.
 - Click the print icon in the upper left of your browser window.

- **Printing a PDF version of the complete manual.** Use the **Complete PDF Manual** link at the top left corner of any page.
 - Click the **Complete PDF Manual** link at the top left corner of any page in the manual. The PDF version of the complete manual opens in a browser window.
 - Click the print icon in the upper left corner of your browser window.



Tip: If your printer supports printing two pages on a single sheet of paper, you can save paper and printer ink by selecting this feature.

Revision History

Part Number	Version Number	Date	Description
202-10623-01	1.0	March 2010	Product update: New firmware and new user Interface

Chapter 1

Introduction

This chapter describes some of the key features of the NETGEAR Wireless N150 Access Point WN604. It also includes the minimum prerequisites for installation (“[System Requirements](#)” on page 1-5.), package contents (“[What’s In the Box?](#)” on page 1-5) and a description of the front and back panels of the WN604 (“[Hardware Description](#)” on page 1-5).

About the NETGEAR Wireless N150 Access Point WN604

The NETGEAR Wireless N150 Access Point WN604 is the basic building block of a wireless LAN infrastructure. It provides connectivity between Ethernet wired networks and radio-equipped wireless notebook systems, desktop systems, print servers, and other devices.

The WN604 provides wireless connectivity to multiple wireless network devices within a fixed range or area of coverage—interacting with a wireless network interface card (NIC) via an antenna. Typically, an individual in-building access point provides a maximum connectivity area of about a 500 foot radius. Consequently, the NETGEAR Wireless N150 Access Point WN604 can support a small group of users in a range of several hundred feet. Most access points can handle between 10 to 30 users simultaneously per radio.

The NETGEAR Wireless N150 Access Point WN604 acts as a bridge between the wired LAN and wireless clients. Connecting multiple WN604 Wireless Access Points via a wired Ethernet backbone can further lengthen the wireless network coverage. As a mobile computing device moves out of the range of one access point, it moves into the range of another. As a result, wireless clients can freely roam from one Access Point to another and still maintain seamless connection to the network.

Key Features and Standards

The WN604 Wireless Access Point is easy-to-use and provides solid wireless and networking support. It also offers a wide range of security options.

Supported Standards and Conventions

The following standards and conventions are supported:

- **Standards Compliance.** The Wireless Access Point complies with the IEEE 802.11b/g/n standards for Wireless LANs.
- **Wi-Fi Protected Setup support.** Wi-Fi Protected Setup (WPS) support, a standard created and certified by the Wi-Fi Alliance for easy and secure home wireless network configuration.
- **Full WPA and WPA2 support.** WPA and WPA2 enterprise-class strong security with RADIUS and certificate authentication as well as dynamic encryption key generation. WPA-PSK and WPA2-PSK preshared key authentication without the overhead of RADIUS servers but with all of the strong security of WPA.
- **DHCP Client Support.** DHCP provides a dynamic IP address to PCs and other devices upon request. The WN604 can act as a client and obtain information from your DHCP server; it can also act as a DHCP server and provide network information for wireless clients.
- **LAN ports.** 4 x 10/100 LAN ports support.

Key Features

The WN604 provides solid functionality, including the following features:

- **Operating Frequency.** The Wireless Access Point operates in the standard 2.4 GHz band. It has Multiple operating modes:
 - **Wireless Access Point.** Operates as a standard 11b/bg/ng access point.
 - **Point-to-Point Bridge.** In this mode, the WN604 only communicates with another bridge-mode wireless access point (with or without clients). Network authentication should be used to protect this communication.
 - **Point-to-Multi-Point Bridge.** In this mode the WN604 is the “Master” for a group of bridge-mode wireless access points. The other bridge-mode wireless access points send all traffic to this “Master”, and do not communicate directly with each other. Network Authentication should be used to protect this traffic.
 - **Client mode.** In this mode the access point acts as a client. It is used to extend the LAN of clients that do not have wireless connectivity
- **Scheduled Wireless ON/OFF.** Schedule wireless to be ON/OFF through certain days of the week and hours of each weekday.

- **Upgradeable Firmware.** Firmware is stored in a flash memory and can be upgraded easily, using only your Web browser, and can be upgraded remotely. In addition to using Web browser to do so, command-line interface and SNMP can also be used.
- **Access Control.** The Access Control MAC address filtering feature can ensure that only trusted wireless stations can use the WN604 to gain access to your LAN.
- **Hidden Mode.** The SSID is not broadcast, assuring only clients configured with the correct SSID can connect.
- **Configuration Backup.** Configuration settings can be backed up to a file and restored.
- **Autosensing Ethernet Connection with Auto Uplink Interface.** Connects to 10/100 Mbps IEEE 802.3 Ethernet networks.
- **LED Indicators.** Power, WPS, Wireless Activity, LAN speed, and LAN activity are easily identified.
- **Wireless Multimedia (WMM) Support.** WMM is a subset of the 802.11e standard. WMM allows wireless traffic to have a range of priorities, depending on the kind of data. Time-dependent information, like video or audio, has a higher priority than normal traffic. For WMM to function correctly, Wireless clients must also support WMM.
- **WMM Power Save Support.** Power Save uses mechanisms from 802.11e and legacy 802.11 to save power (for battery powered equipment) and fine-tune power consumption.

802.11b/g/n Standards-based Wireless Networking

The NETGEAR Wireless N150 Access Point WN604 provides a bridge between Ethernet wired LANs and 802.11b/g/n compatible wireless LAN networks. It provides connectivity between Ethernet wired networks and radio-equipped wireless notebook systems, desktop systems, print servers, and other devices. Additionally, the WN604 supports the following wireless features:

- Aggregation Support
- Reduced Inter Frame Spacing support
- Multiple Input, Multiple Output (MIMO) support
- Distributed coordinated function (CSMA/CA, Back off procedure, ACK procedure, retransmission of unacknowledged frames)
- RTS/CTS handshake
- Beacon generation
- Packet fragmentation and reassembly
- Auto or long preamble
- Roaming among access points on the same subnet

Autosensing Ethernet Connections with Auto Uplink

The WN604 can connect to a standard Ethernet network. The LAN interface is autosensing and capable of full-duplex or half-duplex operation.

The wireless access point incorporates Auto Uplink™ technology. The Ethernet port will automatically sense whether the Ethernet cable plugged into the port should have a “normal” connection such as to a computer or an “uplink” connection such as to a switch or hub. That port will then configure itself to the correct configuration. This feature also eliminates any concerns about crossover cables, as Auto Uplink will accommodate either type of cable to make the right connection.

Compatible and Related NETGEAR Products

For a list of compatible products from other manufacturers, see the Wireless Ethernet Compatibility Alliance Web site (WECA, see <http://www.wi-fi.net>).

The following NETGEAR products work with the WN604 Wireless Access Point:

- FS108P - ProSafe 8 Port 10/100 Switch with 4 Port PoE
- FS116P ProSafe 16 Port 10/100 Desktop Switch with 8 Port PoE
- FS726TP - ProSafe 24 Port 10/100 Smart Switch with 2 Gigabit Ports and 12 Port PoE
- FS728TP - ProSafe 24+4 10/100 Smart Switch with full PoE
- FS752TPS - ProSafe 48 Port 10/100 Stackable Smart Switch with 4 Gigabit Ports and 24 Port PoE
- FSM7328PS - ProSafe 24-port 10/100 L3 Managed Stackable Switch with 24 PoE Ports
- FSM7352PS
- GS724TP
- GS748TP
- WNDA3100 - RangeMax Dual Band Wireless-N USB 2.0 Adapter
- WN121T RangeMax NEXT Wireless-N USB 2.0 Adapter
- WN111 - RangeMax Next Wireless-N USB Adapter
- WG511T 802.11g 108 Mbps Wireless CardBus Adapter
- WG511 802.11g 54 Mbps Wireless CardBus Adapter
- WG111 801.11g 54 Mbps Wireless USB Adapter
- WPN111 - RangeMax Wireless USB 2.0 Adapter

System Requirements

Before installing the WN604, make sure your system meets these requirements:

- A 10/100 Mbps Local Area Network device such as a hub or switch.
- The Category 5 UTP straight through Ethernet cable with RJ-45 connector included in the package, or one like it.
- A 100-240 V, 50-60 Hz AC power source.
- A Web browser for configuration such as Microsoft Internet Explorer 6.0 or above, or Mozilla 3.0 or above.
- At least one computer with the TCP/IP protocol installed.
- 802.11b/g/n-compliant devices, such as the NETGEAR WNDA3100v2 Wireless Adapter.

What's In the Box?

The product package should contain the following items:

- NETGEAR Wireless N150 Access Point WN604.
- Power adapter and cord (12V dc, 1A).
- Straight through Category 5 Ethernet cable.
- *Resource CD* which includes this manual.
- Support Registration card.

Contact your reseller or customer support in your area if there are any missing or damaged parts. You can refer to the Support Information Card for the telephone number of customer support in your area. You should keep the Support Information card, along with the original packing materials, and use the packing materials to repack the WN604 if you need to return it for repair. To qualify for product updates and product warranty registrations, we encourage you to register on the NETGEAR Web site at: <http://www.NETGEAR.com>.

Hardware Description

This section describes the front and rear hardware functions of the WN604.

Front Panel

The WN604 front hardware functions are described below.



Figure 1-1 WN604 Front Panel

The following table explains the LED indicators on the front panel:

Table 1-1. Front Panel LED Indicators

Item	LED	DESCRIPTION
1	Power	Power Indicator
	OFF	No power.
	Solid Amber	AP performing the power on self-test diagnostic.
	Solid Green	Power ON and AP ready
	Blinking Green	Firmware upgrade in process
2	W-Fi WPS Function	WPS LED
	OFF	There is no WPS activity or WPS error and the AP is not in the temporary AP setup locked state
	Blinking Green	There are WPS activities.(0.5 sec on and 0.5 sec off)
3	802.11b/g/N	WLAN LED
	Blinking Blue	Data transmission or receive activity occurs through the wireless
	Solid Blue	Wireless is up and running without wireless data transmission
	OFF	Wireless Interface is turned off
4	4* 10/100 LAN	Link/Active LED
	OFF	No link detected.
	Solid Green	100 Mbps link detected, no data transmission on the port.
	Blinking Green	100 Mbps link detected, data transmission on the port.
	Solid Amber	10 Mbps link detected, no data transmission on the port.
	Blinking Amber	10 Mbps link detected, data transmission on the port.

Rear Panel



Figure 1-2 WN604 Rear Panel

The WN604 rear panel functions are described below:

1. Power Socket

This socket connects to the WN604 12V 1A power adapter.

2. Power ON/OFF switch.

3. 4 x 10/100 RJ-45 Ethernet Ports

Use the WN604 Ethernet RJ-45 port to connect to an Ethernet LAN through a device such as a hub, switch, router, or PoE switch.

4. Restore to Factory Defaults Button

The restore to default button located between the Ethernet RJ-45 connector and the antenna restores the WN604 to the factory default settings.

1. Fixed rear Antenna

The WN604 provides a single fixed antenna on the rear panel.

Side Panel

The WN604 side panel hardware functions are described below.



Figure 1-3 WN604 Side Panel

1. Wireless ON/OFF switch.

Use this switch to enable or disable the radio (see [“Configuring 802.11b/bg/ng Wireless Settings”](#) on page 2-13).

2. WPS Push Button.

Use this push button to automatically configure security settings on the WN604 (see [“Configuring a client using WPS”](#) on page 3-5).

Chapter 2

Basic Installation and Configuration

This chapter describes how to set up your NETGEAR Wireless N150 Access Point WN604 for wireless connectivity to your LAN. This basic configuration will enable computers with 802.11b/g/n wireless adapters to do such things as connect to the Internet, or access printers and files on your LAN.



Note: Indoors, computers can connect over 802.11b/bg/ng or wireless networks at ranges of several hundred feet or more. This distance can allow for others outside your area to access your network. It is important to take appropriate steps to secure your network from unauthorized access. The WN604 Wireless Access Point provides highly effective security features which are covered in detail in [“Understanding Security Profiles”](#) on page 3-2. Deploy the security features appropriate to your needs.

This chapter contains the following sections:

1. [“Wireless Equipment Placement and Range Guidelines”](#)
2. [“Understanding WN604 Wireless Security Options”](#)
3. [“Installing the WN604 Wireless Access Point”](#)
4. [“Logging In Using the Default IP Address”](#)
5. [“Setting Basic IP Options”](#)
6. [“Wireless Settings”](#)
7. [“Setting Up and Testing Basic Wireless Connectivity”](#)

You need to prepare these three things before you can establish a connection through your wireless access point:

- A location for the WN604 that conforms to the [“Wireless Equipment Placement and Range Guidelines”](#) below.
- The wireless access point connected to your LAN through a device such as a hub, switch, router, or Cable/DSL gateway.
- One or more computers with properly configured 802.11b/g/n or wireless adapters.

Wireless Equipment Placement and Range Guidelines

The operating distance or range of your wireless connection can vary significantly based on the physical placement of the wireless access point. The latency, data throughput performance, and notebook power consumption of wireless adapters also vary depending on your configuration choices.



Note: Failure to follow these guidelines can result in significant performance degradation or inability to wirelessly connect to the WN604. For complete performance specifications, see [Appendix A, “Default Settings and Technical Specifications.”](#)

For best results, place your wireless access point:

- Near the center of the area in which your PCs will operate.
- In an elevated location such as a high shelf where the wirelessly connected PCs have line-of-sight access (even if through walls).
- Away from sources of interference, such as PCs, microwaves, and 2.4 GHz cordless phones.
- Away from large metal surfaces.

Putting the antenna in a vertical position provides best side-to-side coverage. Putting the antenna in a horizontal position provides best up-and-down coverage.

If you are using multiple access points for 11b/bg/ng, it is better if adjacent access points use different radio frequency channels to reduce interference. The recommended Channel spacing between adjacent access points is 5 Channels (for example, use Channels 1 and 6, or 6 and 11). For 11a/na, the 6 Channel spacing is not needed.

The time it takes to establish a wireless connection can vary depending on both your security settings and placement. Some types of security connections can take slightly longer to establish and can consume more battery power on a notebook computer.

Understanding WN604 Wireless Security Options

Your wireless data transmissions can be received well beyond your walls by anyone with a compatible adapter. For this reason, use the security features of your wireless equipment. The WN604 Wireless Access Point provides highly effective security features which are covered in detail in the next chapter. Deploy the security features appropriate to your needs.

There are several ways you can enhance the security of your wireless network:

- **Restrict Access Based on MAC address.** You can restrict access to only trusted PCs so that unknown PCs cannot wirelessly connect to the WN604. MAC address filtering adds an obstacle against unwanted access to your network, but the data broadcast over the wireless link is fully exposed.
- **Turn Off the Broadcast of the Wireless Network Name (SSID).** If you disable broadcast of the SSID, only devices that have the correct SSID can connect. This nullifies the wireless network “discovery” feature of some products such as Windows XP, Vista and Unix systems but the data is still fully exposed to a determined snoop using specialized test equipment like wireless sniffers.
- **Use WEP.** Wired Equivalent Privacy (WEP) data encryption provides data security. WEP open authentication and WEP data encryption will block all but the most determined eavesdropper.
- **Use WPA or WPA-PSK.** Wi-Fi Protected Access (WPA) data encryption provides data security. The very strong authentication along with dynamic per frame rekeying of WPA make it virtually impossible to compromise. Because this is a new standard, wireless device driver and software availability may be limited.



Note: WEP and TKIP provide only legacy rates of operation. So, AES is the recommended solution to use the 802.11n rates and speed.

Wi-Fi Protected Setup

You can also use Wi-Fi Protected Setup (WPS) to automatically configure your AP to the best available security options (see [“Wi-Fi Protected Setup \(WPS\)” on page 3-5](#)).

Installing the WN604 Wireless Access Point

Before installing the NETGEAR Wireless N150 Access Point WN604, you should make sure that your Ethernet network is up and working. You will be connecting the access point to the Ethernet network so that computers with 802.11b/g/n wireless adapters will be able to communicate with computers on the Ethernet network. In order for this to work correctly, verify that you have met all of the system requirements, shown on [“System Requirements” on page 1-5](#).

Setting up the WN604 Wireless Access Point



Tip: Before mounting the WN604 in a high location, first set up and test the WN604 to verify wireless network connectivity.

To set up the WN604 Wireless Access Point:

1. Prepare a computer with an Ethernet adapter. If this computer is already part of your network, record its TCP/IP configuration settings.
2. Configure the computer with a static IP address of 192.168.0.210 and 255.255.255.0 for the Subnet Mask.
3. Connect an Ethernet cable from the WN604 to the computer.
4. Turn on your computer, connect the power adapter to the WN604 and verify the following:
 - The PWR power light goes on.
 - The LAN light of the wireless access point is lit when connected to a powered on computer.
 - The WLAN LEDs should be blinking.

Configuring LAN and Wireless Access

To configure the WN604 Ethernet port for LAN access:

1. Connect to the WN604 by opening your browser and entering **http://192.168.0.100** in the address field. The WN604 login screen appears (see [Figure 2-1](#)).
2. Enter **admin** for the user name and **password** for the password, both in lower case letters.

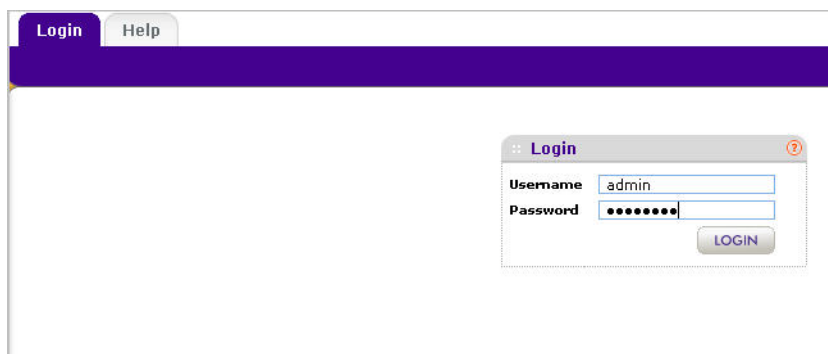

Figure 2-1 Login screen

3. Click **Login**. The main menu of the WN604 displays as shown in [Figure 2-2](#).
 - When the wireless access point is connected to the Internet, under the **Support** tab, select **Documentation** to view the documentation for the wireless access point.
 - On the top-right of the screen, select **Logout** to exit the WN604 setup screens. (You will automatically be logged out of the wireless access point after 5 minutes of no activity.)

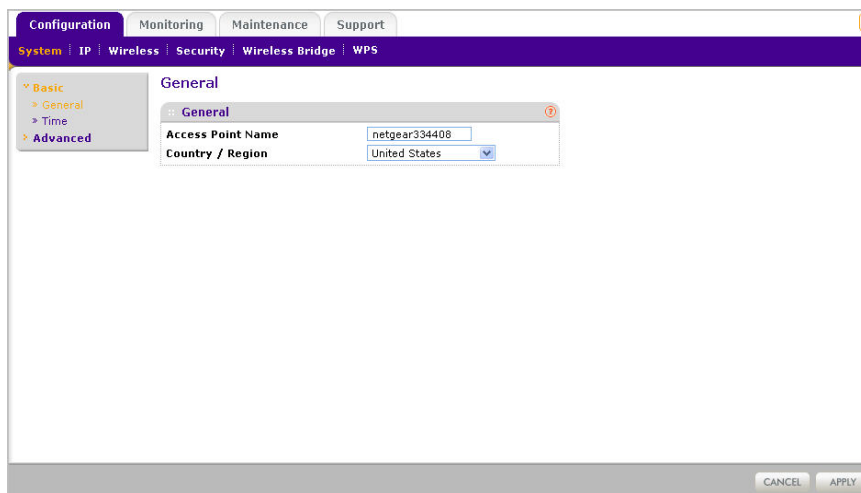



Figure 2-2 Access Point Name and Country / Region

4. **Access Point Name:** Enter the access point name of the WN604.

This unique name is the access point NetBIOS name. The default Access Point Name is located on the bottom label of WN604. The default is netgearxxxxxx, where xxxxxx represents the last 6 digits of the WN604 MAC address. You may modify the default name with a unique name up to 15 characters long.

- From the **Country/Region** pull-down menu, select the region where the WN604 can be used (the default Country/Region is the United States).

	<p>Note: If your country or region is not listed, please check with Netgear Support.</p>
-----------------------------------------------------------------------------------	-------------------------------------------------------------------------------------------------

- Select **Time** from the left panel. The Time screen displays, as shown in [Figure 2-3](#).

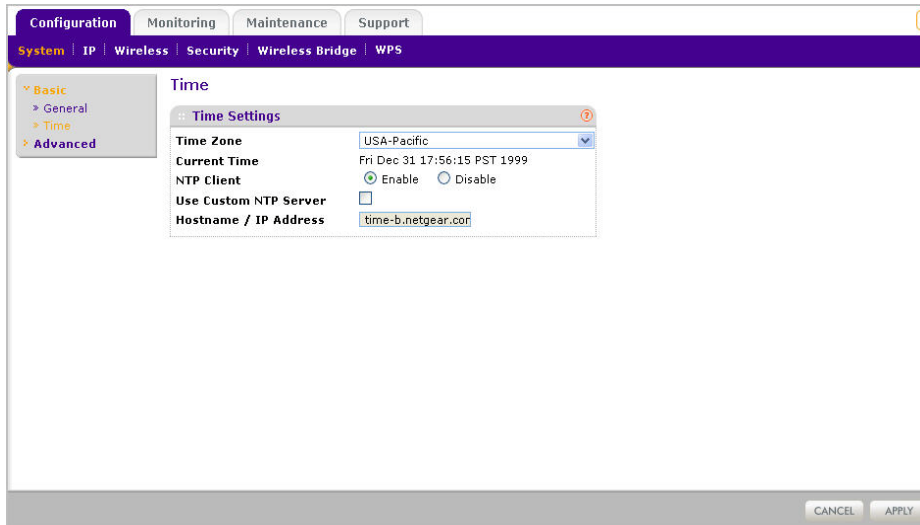

Figure 2-3 Timezone and system time related settings

- Enter the Time Settings for your area. See the online help or [“Configuring Time Settings” on page 2-7](#) for more information about how to configure the settings on this screen.

8. Select **IP** on the main menu. The IP Settings screen displays, as shown in [Figure 2-4](#).

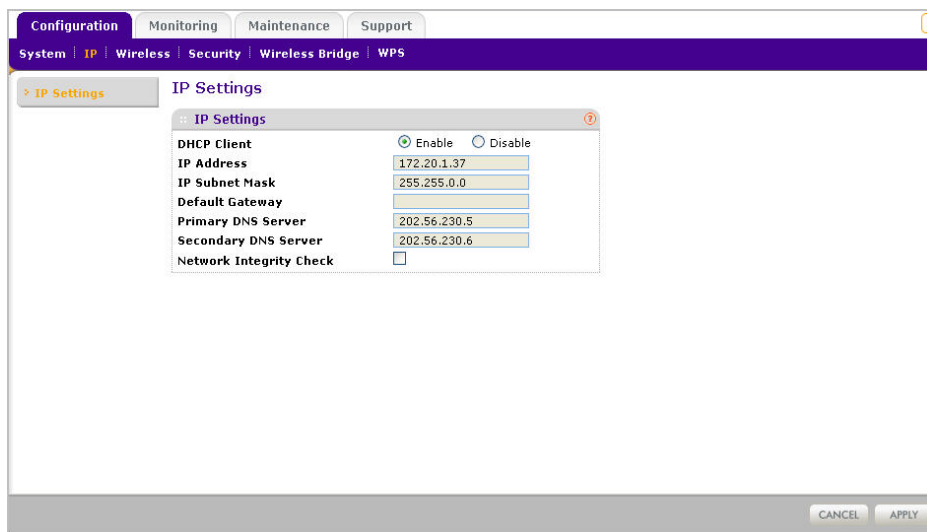

Figure 2-4 IP Settings

9. Configure the IP Address settings appropriate for your network. The default values are suitable for most users and situations. (See the online help or [“Setting Basic IP Options”](#) on [page 2-12](#) for more information about how to configure the settings on this screen.
10. Click **Apply**.

Configuring Time Settings

To configure your time settings:

1. Under the **Configuration** tab, select **System** from the main menu, select **Basic**, and then select **Time**. The Time screen displays, as shown in [Figure 2-5](#).

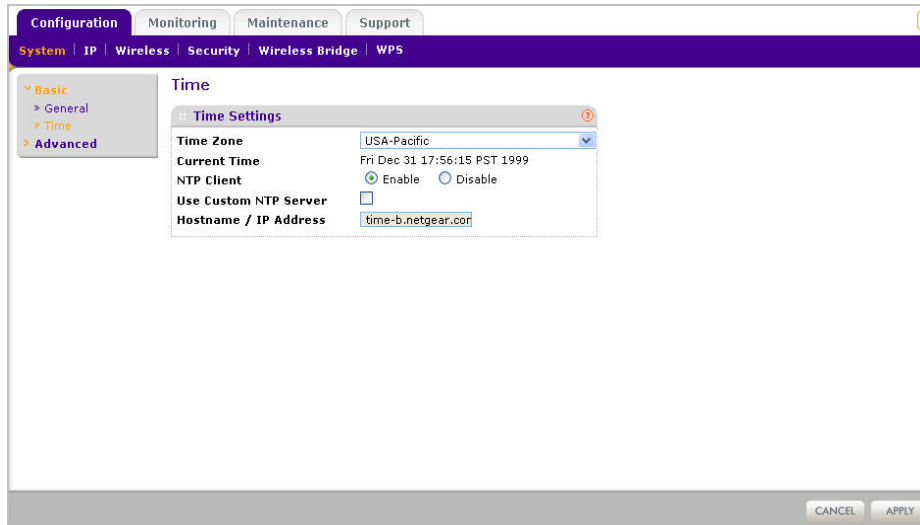

Figure 2-5 Timezone and system time related settings

2. Configure the following information:

- **Time Zone.** From the pull-down menu, select the local time zone for your wireless access point from a list of all available time zones. The default is **USA-Pacific**.
- **NTP Client.** Enable NTP Client to synchronize the time of the access point with an NTP Server. The Default is Enabled.

	Note: You must have an Internet connection to get the current time.
-------------------------------------------------------------------------------------	----------------------------------------------------------------------------

- **Use Custom NTP Server.** Check the option if you have a custom NTP server. The default is Disabled.
- **Hostname / IP Address.** Enter the host name or the IP address of the custom NTP server. The default is time-b.netgear.com.

3. Click **Apply**.

Configuring Wireless Access

To configure your wireless settings for 11b/bg/ng:

1. From the main menu under **Configuration**, select **Wireless**. The Wireless Settings screen displays, as shown in [Figure 2-6](#).
2. Enter the wireless settings for your area. See the online help or “[Wireless Settings](#)” on [page 2-13](#).
3. Click **Apply** to save your settings.

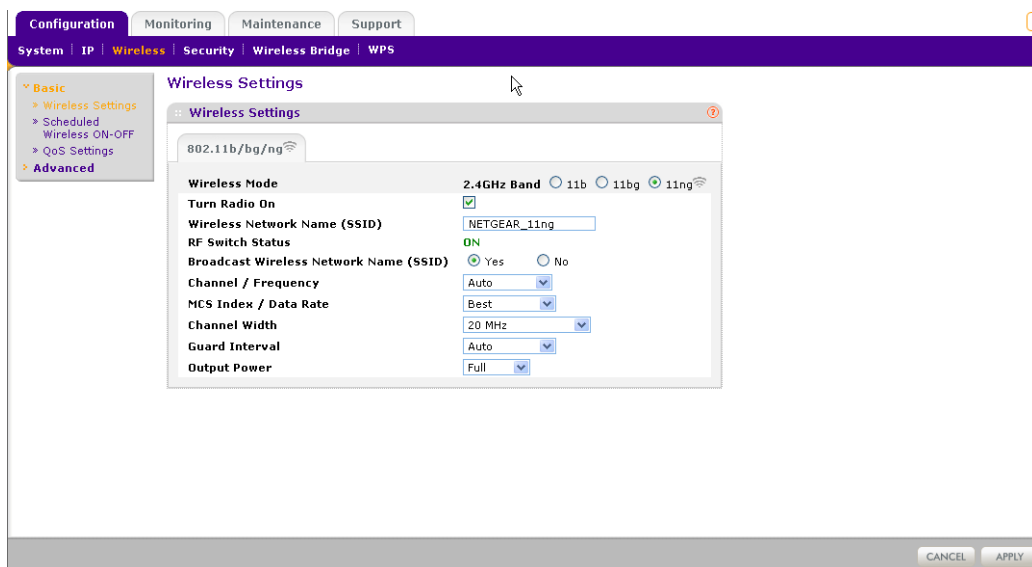

Figure 2-6 Basic Wireless Settings for 802.11b/bg/ng

When you have completed the setup steps, you can deploy the WN604 in your network. If needed, you can now reconfigure the computer you used in step 1 (from the Static IP) back to its original TCP/IP settings.

Deploying the WN604 Wireless Access Point

To deploy the WN604 Wireless Access Point:

1. Disconnect the WN604 and position it where it will be deployed. The best location is elevated, such as wall mounted or on the top of a cubicle, at the center of your wireless coverage area, and within line of sight of all the mobile devices.

2. Lift the antennae on either side so that they are vertical.



Note: Refer to the antenna positioning and wireless mode configuration information in the [Advanced Configuration](#) chapter of the Reference Manual.

3. Connect an Ethernet cable from your WN604 Wireless Access Point to a LAN port on your router, switch, or hub.



Note: By default, WN604 is set with the DHCP client disabled. If your network uses dynamic IP addresses, you must change this setting. To connect to the WN604 after the DHCP server on your network assigns it a new IP address, enter the wireless access point name into your Web browser. The default wireless access point name is netgearxxxxxx, where xxxxxx represents the last 6 bytes of the MAC address. The default name is printed on the bottom label of the WN604.

4. Connect the power adapter to the wireless access point and plug the power adapter in to a power outlet. The PWR, LAN, and Wireless LAN lights and should light up.

Verifying Wireless Connectivity

Using a computer with an 802.11b/bg/ng wireless adapter with the correct wireless settings needed to connect to the WN604 (SSID, WEP/WPA, MAC ACL, etc.), verify connectivity by using a browser such as Mozilla Firefox or Internet Explorer to browse the Internet, or check for file and printer access on your network.

The default SSID for the 802.11b/bg/ng wireless mode is NETGEAR-11g. The SSID of any wireless access adapters must match the SSID configured in the NETGEAR Wireless N150 Access Point WN604. If they do not match, no wireless connection will be made.



Note: If you are unable to connect, see [Chapter 6, “Troubleshooting and Debugging.”](#)

Logging In Using the Default IP Address

After you install the WN604, log in to the wireless access point to configure the basic settings and the wireless settings. The WN604 is set, by default, with the IP address of 192.168.0.100 with DHCP disabled.



Note: The computer you are using to connect to the WN604 should be configured with an IP address that starts with 192.168.0.x and a Subnet Mask of 255.255.255.0.

To log in using the default IP Address:

1. Open a Web browser such as Internet Explorer or Mozilla Firefox.
2. Connect to the WN604 by entering its default address of **http://192.168.0.100** into your browser. The login screen displays. Enter **admin** for the user name and **password** for the password, both in lower case letters.

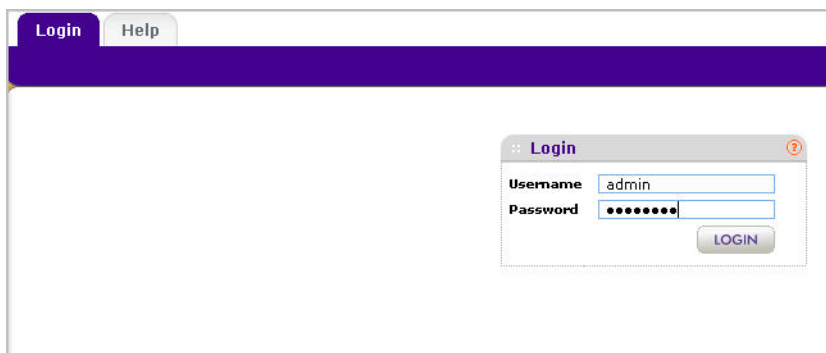

Figure 2-7 Connecting to the Access Point

3. Click **Login**.

Your Web browser should automatically find the WN604 Wireless Access Point and display the home screen.

Setting Basic IP Options

The basic IP settings for your wireless access point are entered on this screen. Most of the default settings will work in most cases. However, if your wireless access point is part of a more complex LAN network, then modify the settings to meet the requirements of your network based on the explanation of the various fields.

To configure the basic IP settings of your wireless access point:

1. Under **Configuration**, select **IP**, and then IP Settings. The IP Settings screen displays as shown in [Figure 2-8](#) below.

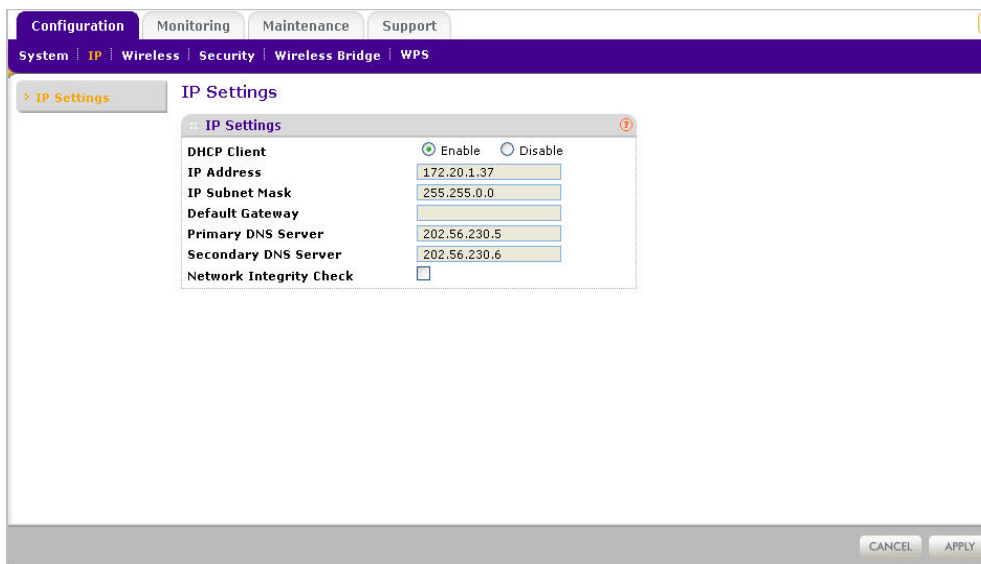

Figure 2-8 Basic IP options

2. Enter the IP Address fields of the WN604.
 - **DHCP Client.** By default, the Dynamic Host Configuration Protocol (DHCP) client is disabled. If you have a DHCP server on your LAN and you enable DHCP, the wireless access point will get its IP address, subnet mask and default gateway settings automatically from the DHCP server on your network when you connect the WN604 to your LAN.
 - **IP Address.** Enter the IP Address of your wireless access point. The default IP address is **192.168.0.100**. To change it, enter an unused IP address from the address range used on your LAN; or enable DHCP.

- **IP Subnet Mask.** The Access Point will automatically calculate the subnet mask based on the IP address that you assign. Otherwise, you can use 255.255.255.0 (the default) as the subnet mask.
 - **Default Gateway.** Enter the IP address of the gateway for your LAN. For more complex networks, enter the address of the router for the network segment to which the wireless access point is connected.
 - **Primary DNS Servers.** The WN604 will use this IP address as the primary Domain Name Server used by stations on your LAN.
 - **Secondary DNS Servers.** The WN604 will use this IP address as the secondary Domain Name Server used by stations on your LAN.
 - **Network Integrity Check.** Check this box to enable the WN604 to validate that the upstream link is active before allowing wireless associations. If you set this option you must ensure your default gateway is configured.
3. Click **Apply** to save your basic IP settings.

Wireless Settings

The following sections describe how to configure the available wireless settings.

Configuring 802.11b/bg/ng Wireless Settings

To configure the wireless settings of your 802.11b/bg/ng wireless access point:

1. From main menu under **Configuration**, select **Wireless**. The Wireless Settings screen of your 802.11b/bg/ng wireless access point displays, as shown in [Figure 2-9](#) below.

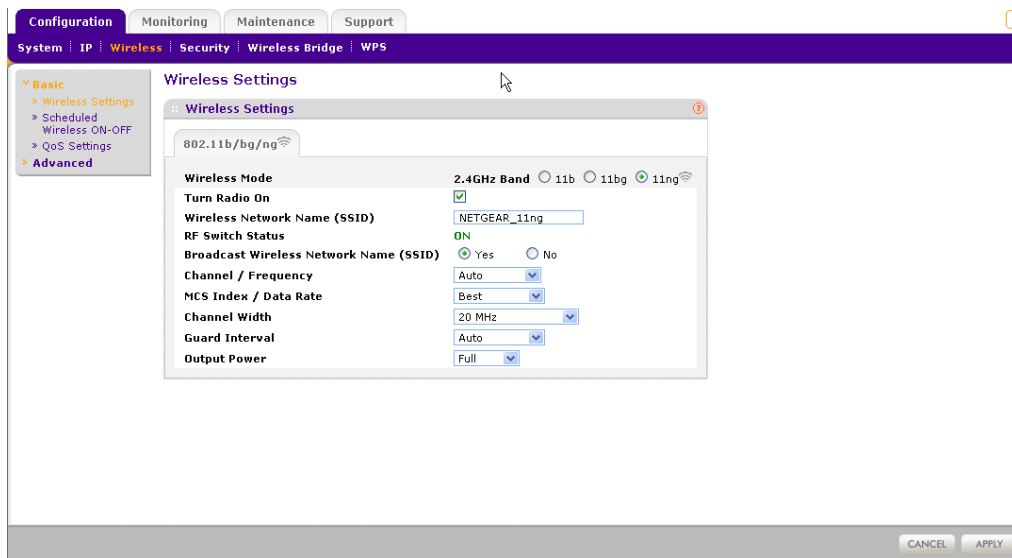



Figure 2-9 Configure wireless settings 802.11b/bg/ng

2. Configure the Wireless LAN settings based on the following field descriptions:
 - **Wireless Mode.** Select the desired wireless operating mode. The default is 11ng. The options are:
 - **11b** – All 802.11b wireless stations can be used. (The 802.11g wireless stations can still be used if they can operate in 802.11b mode.)
 - **11bg** – Both 802.11b and 802.11g wireless stations can be supported.
 - **11ng** – All 11b, 11g, and 11ng wireless stations can be used. This is the default. If you select this option, then two additional options, Channel Width and Guard Interval, are displayed.

 **Note:** If you select one of these option and if other settings on this screen are disabled, then you must select the Turn Radio On radio button to enable available options on this screen.

- **Turn Radio On.** On by default, you can also turn off the radio to disable access through this device. This can be helpful for configuration, network tuning, or troubleshooting activities.
- **Wireless Network Name (SSID).** This is the name of your wireless network. It is set to the default name of NETGEAR_11ng for 802.11b/bg/ng.
- **RF Switch Status.** The WN604 also has an external hardware switch to enable or disable the radio (RF). This field shows its current status. When the RF switch is off, you cannot change wireless parameters.
- **Broadcast Wireless Network Name (SSID).** If you disable broadcast of the SSID, only devices that have the correct SSID can connect. This nullifies the wireless network “discovery” feature of some products such as Windows XP, Vista and Unix systems but the data is still fully exposed to a determined snoop using specialized test equipment like wireless sniffers. Default is enabled.
- **Channel/Frequency.** From the pull-down menu, select the channel you wish to use on your wireless LAN. The wireless channel in use will be between 1 to 11 for US and Canada, 1 to 13 for Europe and Australia. The default is channel Auto.

It should not be necessary to change the wireless channel unless you experience interference (shown by lost connections and/or slow data transfers). Should this happen, you may need to experiment with different channels to see which is the best. Alternatively, you can select the Auto channel option for the AP to intelligently pick the channel with least interference. See the article on “Wireless Channels” available on the NETGEAR website. (A link to this article and other articles of interest can be found in [Appendix B, “Related Documents.”](#)). When selecting or changing channels, some points to bear in mind:

- Access points use a fixed channel. You can select the channel used. This allows you to choose a channel which provides the least interference and best performance. In the USA and Canada, 11 channels are available
 - If using multiple access points, it is better if adjacent access points use different channels to reduce interference. The recommended channel spacing between adjacent access points is 5 channels (for example, use channels 1 and 6, or 6 and 11).
 - Wireless stations normally scan all channels, looking for an access point. If more than one access point can be used, the one with the strongest signal is used. This can only happen when the various access points are using the same SSID.
- **MCS Index/Data Rate.** From the pull-down menu, select the available transmit data rate of the wireless network. Also, depending on the band selected, the set of rates will vary. The possible data rates supported are:

- **Data Rates for Channel Width=20MHz and Guard Interval=short (400ms):** Best, 7.2 Mbps, 14.4 Mbps, 21.7 Mbps, 28.9 Mbps, 43.3 Mbps, 57.8 Mbps, 65 Mbps, 72.2 Mbps.
 - **Data Rates for Channel Width=20MHz and Guard Interval=long (800ms):** Best, 6.5 Mbps.
 - **Data Rates for Channel Width=40MHz and Guard Interval=short:** Best, 15 Mbps, 30 Mbps, 45 Mbps, 60 Mbps, 90 Mbps, 120 Mbps, 135 Mbps, 150 Mbps.
 - **Data Rates for Channel Width=40MHz and Guard Interval=long:** Best, 13.5 Mbps, 27 Mbps, 40.5 Mbps, 54 Mbps, 81 Mbps, 108Mbps, 121.5 Mbps, 135 Mbps.
 - **Channel Width.** From the pull-down menu, select the desired channel width.
 - 20 MHz - This is the static, legacy mode. It gives the least throughput.
 - 40 MHz - This is the static, high-throughput mode. Legacy clients will not be able to connect in this mode.
 - 20/40 MHz - This is the dynamic, compatibility mode.
 - **Guard Interval.** From the pull-down menu, select the desired guard interval. The guard interval protects from interference from other transmissions. The default is Auto.
 - **Output Power.** From the pull-down menu, select the transmit power of the access point. The options are Full, Half, Quarter, Eighth, and Minimum. Decrease the transmit power if two or more APs are close together and use the same channel frequency. The default is Full. (The transmit power may vary depending on the local regulatory regulations.)
3. Click **Apply** to save your 802.11b/bg/ng wireless settings.

Configuring Basic QoS Settings

Wi-Fi Multimedia Support (WMM). Wireless Multimedia (WMM) is a subset of the 802.11e standard. WMM allows wireless traffic to have a range of priorities, depending on the type of data.

Time-dependent information, such as video or audio, has a higher priority than normal traffic. For WMM to function correctly, Wireless clients must also support WMM.

To configure basic wireless QoS settings for 11b/bg/ng and 11a/na:

1. Under the **Configuration** tab, select **Wireless** from the main menu, select **Basic**, and then select **QoS Settings** from the left panel. The QoS Settings screen displays, as shown in [Figure 2-10](#).

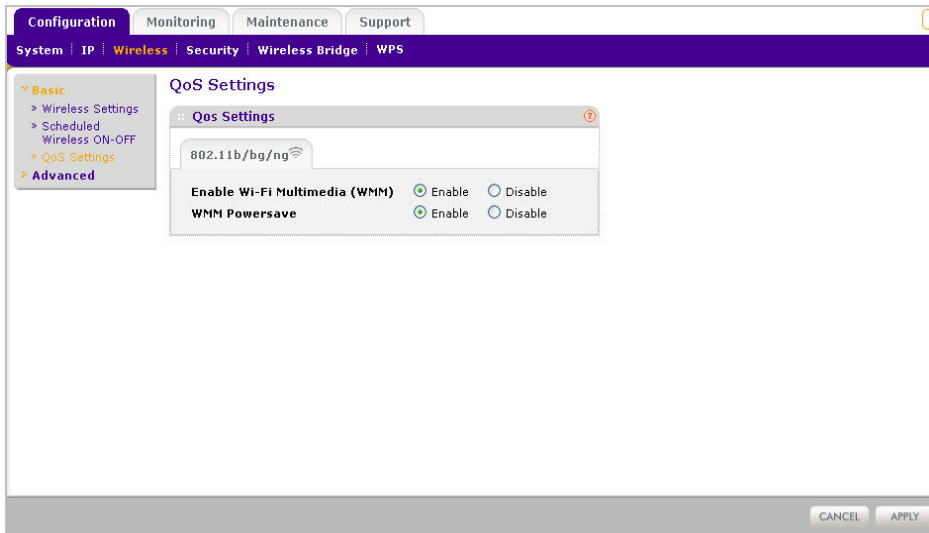

Figure 2-10 Basic QoS settings screen

2. Wi-Fi Multimedia (WMM) is enabled by default. Select the **Disable** radio button to disable WMM support.
3. WMM Power Save is enabled by default. Select the **Disable** radio button to disable WMM power save.
4. Click **Apply** to save your settings

Setting Up and Testing Basic Wireless Connectivity

Follow the instructions below to set up and test basic wireless connectivity. Once you have established basic wireless connectivity, you can enable security settings appropriate to your needs.

1. From your Web browser, log in to the WN604 using its default address of **http://192.168.0.100**. Use the default user name of **admin** and default password of **password**— or use a new LAN address and password if you have set them up.
2. From the main menu under **Configuration**, select **System**. Verify that the correct Country/Region in which the wireless interface will operate has been selected.
3. Click **Apply** to save any changes.
4. Under the **Configuration** tab, select **Wireless** from the main menu. Ensure that the auto channel (default) feature is selected for your network. This feature selects a channel that has the least interference.

It should not be necessary to change the wireless channel unless you notice interference problems or are near another wireless access point. Select a channel that is not being used by any other wireless networks within several hundred feet of your wireless access point.

5. Click **Apply** to save any changes.
6. Under the **Configuration** tab, select **Security** from the main menu. For initial configuration and testing, the Security Profile Settings are set to Open System and the default SSID to NETGEAR_11ng. (see [“Understanding Security Profiles”](#) on page 3-2 to configure a profile).



Note: The SSID of any station must match the SSID you configured in the WN604 Wireless Access Point. If they do not match, you will not get a wireless connection to the WN604.

7. Click **Apply** to save any changes.
8. Configure and test your PCs for wireless connectivity

Program the wireless adapter of your PCs to have the same SSID that you configured in the WN604. Check that they have a wireless link and are able to obtain an IP address by DHCP from the WN604.



Note: If you are configuring the WN604 from a wireless computer and you change the SSID, channel, or Security Profile settings, you will lose your wireless connection when you click Apply. You must then change the wireless settings of your computer to match the new settings.

Once your PCs have basic wireless connectivity to the WN604, you can configure the advanced wireless security functions.

Chapter 3

Configuring Security

This chapter helps you to configure the security settings on your WN604, including the new and simple Wi-Fi Protected Setup (WPS) method. It consists of the following sections.

1. “Understanding Security Profiles”
2. “Wi-Fi Protected Setup (WPS)”
 - “Configuring a client using WPS”
3. “Configuring Security Manually”
 - “SSID and WEP/WPA Settings Setup Form”
 - “Configuring the RADIUS Server Settings”
 - “Setting up a Security Profile”
 - “Configuring WEP”
 - “Configuring WPA with RADIUS”
 - “Configuring WPA2 with RADIUS”
 - “Configuring WPA and WPA2 with RADIUS”
 - “Configuring WPA-PSK”
 - “Configuring WPA2-PSK”
 - “Configuring WPA-PSK and WPA2-PSK”
 - “Restricting Wireless Access by MAC Address”

Understanding Security Profiles

Security Profiles let you configure unique security settings for each SSID. You can configure only one 802.11b/bg/ng wireless security profile on the WN604 (see [Figure 3-1](#)) which is the default profile..



Note: If you are using a RADIUS Server, configure the RADIUS settings first, as described in the “[Configuring WPA with RADIUS](#)” on page 3-14.

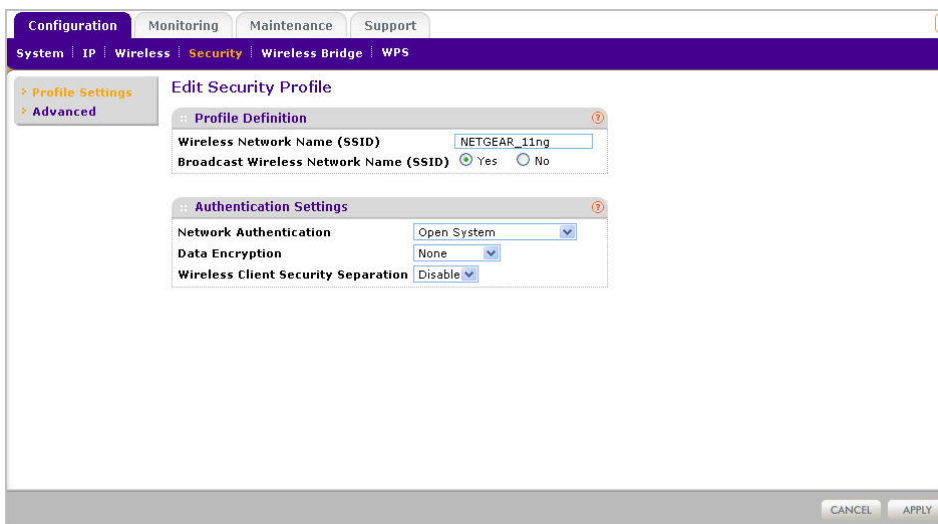

Figure 3-1 Edit Security Profile

An overview of the information that is required to set up a Security Profile follows—including a description of the Network Authentication choices that are available:

- **Profile Definition.** Configure the following settings:
 - **Wireless Network Name (SSID).** This is the name of your wireless network. It is set to the default name of NETGEAR_11ng

- **Broadcast Wireless Network Name (SSID).** If you disable broadcast of the SSID, only devices that have the correct SSID can connect. This nullifies the wireless network “discovery” feature of some products such as Windows XP, Vista and Unix systems but the data is still fully exposed to a determined snoop using specialized test equipment like wireless sniffers. Default is enabled.
- **Authentication Settings.** Configure the following settings:
 - **Network Authentication.** The WN604 Access Point is set by default as an open system with no authentication. When setting up Network Authentication, bear in mind the following:
 - If you are using Access Point mode, then all options are available. In bridge mode some options may be unavailable.
 - Not all wireless adapters support WPA or WPA2. Windows XP and Windows 2000 with Service Pack 3 do include the client software that supports WPA. However, client software is required on the client. Consult the product documentation for your wireless adapter and WPA or WPA2 client software for instructions on configuring WPA2 settings.

You can configure the WN604 to use the types of network authentication shown in the table below.

Table 3-1. Network Authentication Types

Type ^a	Description
Open System	Can be used with WEP encryption or no encryption.
Shared Key	You must use WEP encryption and enter at least one shared key.
WPA with RADIUS	You must configure the RADIUS Server Settings to use this option.
WPA2 with RADIUS (WPA2 is a later version of WPA.)	Only select this if all clients support WPA2. If selected, you must use AES encryption and configure the RADIUS Server Settings.
WPA and WPA2 with RADIUS	This selection allows clients to use either WPA (with TKIP) or WPA2 (with AES). If selected, you must use TKIP + AES encryption and configure the RADIUS Server Settings.
WPA-PSK	You must use TKIP or TKIP + AES encryption and enter the WPA passphrase (Network key).
WPA2-PSK (WPA2 is a later version of WPA)	Only select this if all clients support WPA2. If selected, you must use AES or TKIP + AES encryption and enter the WPA passphrase (Network key).
WPA-PSK and WPA2-PSK	This selection allows clients to use either WPA (with TKIP) or WPA2 (with AES). If selected, you must use TKIP + AES encryption and enter the WPA passphrase (Network key).

a. All options are available if using Access Point mode. In bridge modes some options may be unavailable.

- **Data Encryption.** The available options depend on the Network Authentication setting selected (see [Table 3-1](#) above); otherwise, the default is None. The Data Encryption settings are explained in the table below:

Table 3-2. Data Encryption Settings

Data Encryption Type	Description
None	No encryption is used.
64 bits WEP	Standard WEP encryption, using 40/64 bit encryption.
128 bits WEP	Standard WEP encryption, using 104/128 bit encryption.
152 bits WEP	Proprietary mode that will only work with other wireless devices that support this mode.
TKIP	This is the standard encryption method used with WPA and WPA2.
AES	This is the standard encryption method for WPA2.
TKIP + AES	This setting supports both WPA and WPA2. Broadcast packets use TKIP. For unicast (point-to-point) transmissions, WPA clients use TKIP, and WPA2 clients use AES.

- Use of Passphrases and Keys are explained below:
 - **Passphrase.** To use the Passphrase to generate the WEP keys, enter a passphrase and click the Generate Keys button. You can also enter the keys directly. These keys must match the other wireless stations.
 - **Key 1, Key 2, Key 3, Key 4.** If using WEP, select the key to be used as the default key. Data transmissions are always encrypted using the default key. The other keys can only be used to decrypt received data.
 - **WPA Preshared Key Passphrase.** If using WPA-PSK or WPA2-PSK, enter the passphrase here. All wireless stations must use the same passphrase (network key). The network key must be from 8 to 64 characters in length.
- **Wireless Client Security Separation.** If enabled, the associated wireless clients will not be able to communicate with each other. (This feature is intended for hotspots and other public access situations.) The default is Disabled.

Wi-Fi Protected Setup (WPS)

WPS is a new and simple method that lets you easily and securely add a client to the WN604 Wireless Access Point in a home network. The method allows home users who do not understand all the available security options to configure Wi-Fi Protected Setup.

Configuring a client using WPS

The wireless client must support WPS for this method to work. Check the manual that came along with the wireless client machine.

A wizard will guide you through the steps to add a wireless client to the network, as shown below:

1. Click **Configuration** > **WPS** on the main menu. The WPS Settings screen opens, as shown, along with explanations of the fields:

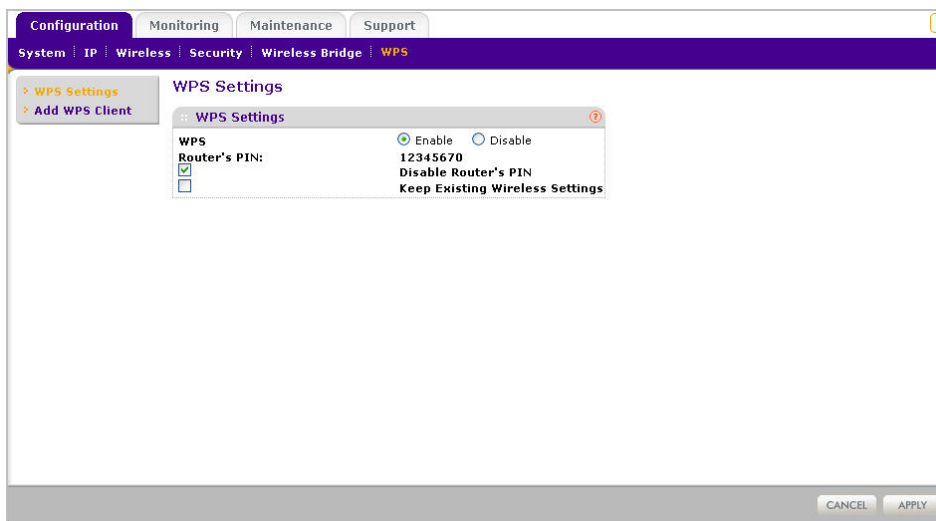



Figure 3-2 WPS settings

- **WPS.** Click the **Enable** radio button to enable WPS on your WN604.
- **AP's PIN:** This is the PIN that a registrar can use to configure the WN604's wireless settings through WPS. This PIN is also available on the AP's product label. Users can use an external registrar to configure the AP's SSID and security settings through WPS, and they will be prompted to enter the PIN that is displayed here.

	<p>Warning: By using this AP's WPS PIN, an external registrar can set or get the AP's wireless settings. So a wireless external registrar can get the AP's wireless settings through WPS with the AP's PIN, and apply the settings to get itself connected to the router.</p>
-----------------------------------------------------------------------------------	--------------------------------------------------------------------------------------------------------------------------------------------------------------------------------------------------------------------------------------------------------------------------------------

- **Disable AP's PIN.** Click in the checkbox if you wish to disable the AP's PIN. An external registrar can only configure the router's wireless settings through WPS when the AP's PIN is enabled. The default is Enable.
 - **Keep Existing Wireless Settings:** Check this option if you wish to keep the current wireless settings, i.e. the WN604 is in the WPS configured state. This option is unchecked by default (i.e. the WN604 is unconfigured by default).
2. Click the **Add WPS Client** option in the left pane. The Add WPS Client information screen appears, as shown below:



Figure 3-3 Add WPS client info

3. After reading the information, click the *Next* button. The Select a Setup Method screen appears, as shown below:

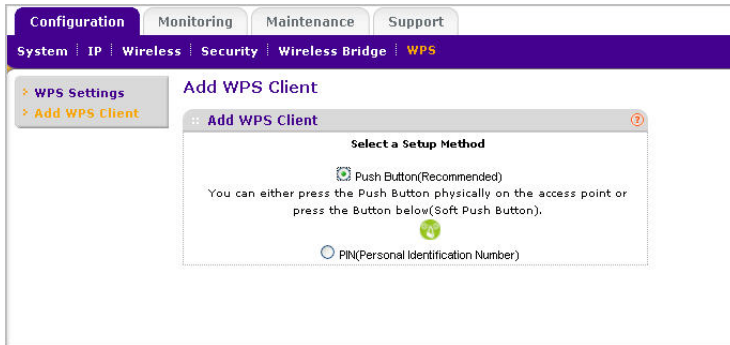

Figure 3-4 Select setup method

4. Select the Push Button method (default) which lets you add a client with a single click (using the WPS push button on the side panel of the WN604 and the push button on the client), or the PIN method. The PIN Number method requires the user to enter the wireless client's PIN, which should be prompted on the client's utility GUI. The Push Button method is easier while PIN Number method is more secure
5. A progress bar on the Connecting to New Wireless Client page shows the progress of the WPS process and the process to collect client's information.

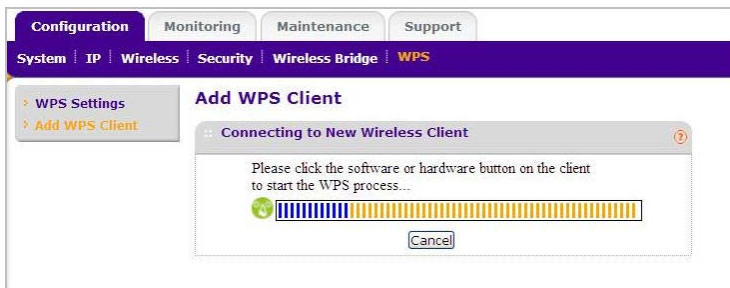

Figure 3-5 Connecting to a wireless client

6. If the wireless client is added successfully and the WN604's wireless settings have been changed, a Success dialog appears with a message. The the user can click to view the new settings.:



Figure 3-6 WPS success - settings changed

7. If the settings have not been changed, the user can click on the Success dialog to return to the Add WPS Client screen.
8. In case of an error in completing the WPS process, refer to the help provided.

Configuring Security Manually

In case you are configuring security on your WN604 Wireless Access Point manually, the remaining sections of this chapter will guide you through the process.

SSID and WEP/WPA Settings Setup Form

For a new wireless network, print or copy this form and fill in the configuration parameters. For an existing wireless network, the person who set up or is responsible for the network will be able to provide this information. Be sure to set the Regulatory Domain correctly as the first step.

- **SSID:** The Service Set Identification (SSID) identifies the wireless local area network. NETGEAR_11ng is the default WN604 SSID. However, you may customize it by using up to 32 alphanumeric characters. Write your customized SSID on the line below.

Note: The SSID in the wireless access point is the SSID you configure in the wireless adapter card. All wireless nodes in the same network must be configured with the same SSID:

- Authentication:

Circle one: Open System or Shared Key. (Choose Shared Key for more security.)

Note: If you select shared key, the other devices in the network will not connect unless they are set to Shared Key as well and have the same keys in the same positions as those in the WN604.

- WEP Encryption Keys.

Circle one: 64, 128, or 152 bits. (Enter all four keys for the Key Size chosen.)

Key 1: _____

Key 2: _____

Key 3: _____

Key 4: _____

- WPA-PSK (Preshared Key)

Record the WPA-PSK key. Key: _____

- WPA RADIUS Settings. For WPA, record the following settings for the primary and secondary RADIUS servers:

Server Name/IP Address: Primary _____ Secondary _____

Port: _____

Shared Secret: _____

Use the procedures described in the following sections to configure the WN604. Store this information in a safe place.

Configuring the RADIUS Server Settings

You can setup or modify the RADIUS Server settings to compliment Network Authentication security options. The RADIUS Server must be used with Legacy 802.1x, and can be used with WPA and WPA2 Network Authentication. When using a RADIUS Server, the RADIUS Server settings must be configured before completing the Network Authentication security profile (see [“Configuring WPA with RADIUS”](#) on page 3-14, [“Configuring WPA2 with RADIUS”](#) on page 3-16, or [“Configuring WPA and WPA2 with RADIUS”](#) on page 3-17 for specifics on implementing these security options).



Note: The RADIUS Server Settings apply to all profiles. They only need to be configured once per wireless access point.

To set up or modify the RADIUS Server Settings:

1. From your Web browser, log in to the WN604 using the default LAN address of **http://192.168.0.100**, user name **admin** and password **password**, or use the LAN address and password that you set up.
2. Under the **Configuration** tab, select **Security** on the main menu, select **Advanced** from the left panel, and then select **RADIUS Server Settings**. The RADIUS Server Settings screen displays, as shown in [Figure 3-7](#).

	IP Address	Port	Shared Secret
Primary Authentication Server	<input type="text"/>	1812
Secondary Authentication Server	<input type="text"/>	1812
Primary Accounting Server	<input type="text"/>	1813
Secondary Accounting Server	<input type="text"/>	1813

Figure 3-7 RADIUS server settings

3. Enter the following RADIUS Server settings:
 - **Authentication Server.** This configuration is required for authentication using a RADIUS Server. The IP Address, Port Number, and Shared Secret are required for communication with the Primary RADIUS Server. You can also configure a Secondary RADIUS Server to use, if the Primary RADIUS Server fails.
 - **IP Address.** The IP address of the RADIUS Server.
 - **Port Number.** The port number of the RADIUS Server. The default is 1812.

- **Shared Secret.** This is shared between the Wireless Access Point and the RADIUS Server while authenticating the supplicant (wireless client).
- **Accounting Server.** This configuration is required for accounting using a RADIUS Server. The IP Address, Port Number, and Shared Secret are required for communication with the Primary RADIUS Server. You can also configure a Secondary RADIUS Server to use if the Primary RADIUS Server fails.
 - **IP Address.** The IP address of the RADIUS Server.
 - **Port Number.** Port number of the RADIUS Server. The default: 1813
 - **Shared Secret.** This is shared between the Wireless Access Point and the RADIUS Server while authenticating the supplicant (wireless client).

4. Click **Apply** to save your settings.

Setting up a Security Profile

The WN604 allows you to set up a single security profile for 802.11b/bg/ng, which is the default profile..



Note: If you are using a RADIUS Server, configure the RADIUS settings first, as described in the [“Configuring the RADIUS Server Settings”](#) on page 3-9.

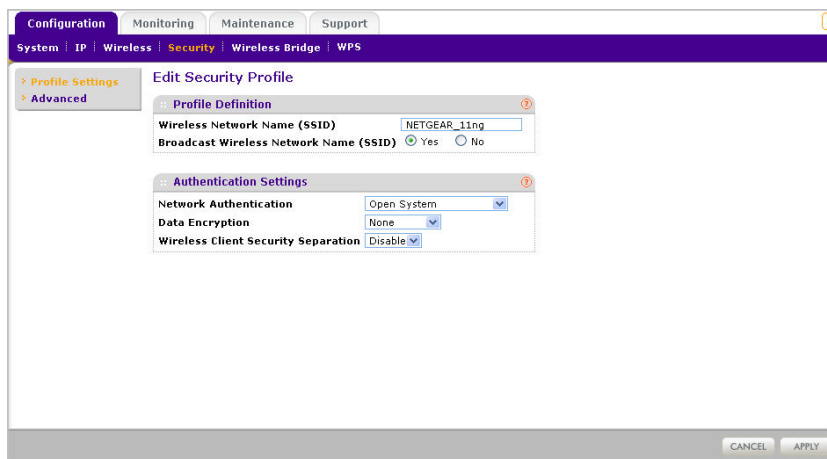

Figure 3-8 Edit security profile settings

To configure a Security Profile:

1. From your Web browser, log in to the WN604 using the default LAN address of **http://192.168.0.100**, user name **admin** and password **password**, or use the LAN address and password that you set up.
2. Under the **Configuration** tab, select **Security** from the main menu. The screen for the Edit Security Profile displays as shown in [Figure 3-8](#) above.
3. Enter the **Wireless Network Name (SSID)** to identify the wireless network. It is set by default to NETGEAR_11ng.
4. Enable or disable the **Broadcast Wireless Network Name (SSID)**. It is enabled by default. (If it is broadcast, it can be easily detected by other clients.)
5. From the **Network Authentication** pull-down menu, select the Network Authentication Type you want to use for this profile:
 - To configure WEP encryption for Open Systems or Shared Key, see [“Configuring WEP” on page 3-12](#).
 - To configure WPA with RADIUS, see [“Configuring WPA with RADIUS” on page 3-14](#).
 - To configure WPA2 with RADIUS, see [“Configuring WPA2 with RADIUS” on page 3-16](#).
 - To configure WPA and WPA2 with RADIUS, see [“Configuring WPA and WPA2 with RADIUS” on page 3-17](#).
 - To configure WPA-PSK, see [“Configuring WPA-PSK” on page 3-19](#).
 - To configure WPA2-PSK, see [“Configuring WPA2-PSK” on page 3-20](#).
 - To configure WPA-PSK and WPA2-PSK, see [“Configuring WPA-PSK and WPA2-PSK” on page 3-20](#).
6. **Data Encryption:** Select data encryption strength from the pull down menu.
7. **Wireless Client Security Separation** is disabled by default. If enabled, the associated wireless clients will not be able to communicate with each other.
8. Click **Apply** to save your Security Profile settings.

Configuring WEP

To configure WEP data encryption:

1. From the **Network Authentication** drop-down menu, choose either **Open System** or **Shared Key** authentication.

2. From the Data Encryption drop-down menu, select encryption strength (64 bits, 128 bits, or 152 bits).
3. You manually or automatically program the four data encryption keys. These values must be identical on all PCs and wireless access points in your network. Choose either:
 - Automatic – Enter a word or group of printable characters in the Passphrase box and click the Generate button. The four key boxes will be automatically populated with key values.
 - Manual – Enter the number of hexadecimal digits appropriate to the encryption strength: 10 digits for 64-bit, 26 digits for 128-bit and 32 digits for 152-bit (any combination of 0-9, a-f, or A-F)
Select which of the four keys will be the default.

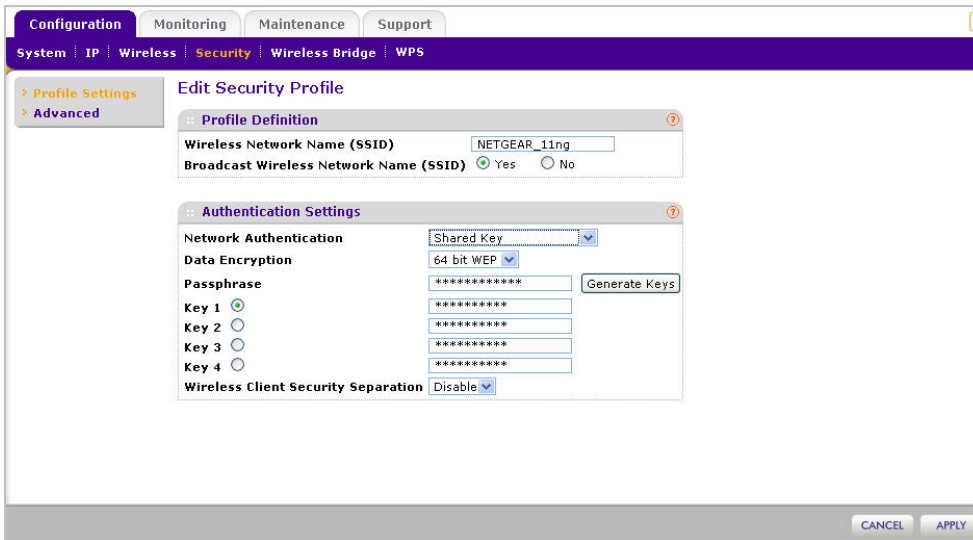

Figure 3-9 Configure WEP Shared Key

4. Select the key to be used as the default key by checking the radio box. (Data transmissions are always encrypted using the default key.)
See the document “Wireless Communications” for a full explanation of each of these options, as defined by the IEEE 802.11 wireless communication standard. A link to this document on the NETGEAR website is in [Appendix B, “Related Documents.”](#)
5. **Wireless Client Security Separation** is disabled by default. If enabled, associated wireless clients will not be able to communicate with each other. (This feature is intended for hotspots and other public access situations.)
6. Click **Apply** to save your settings.



Note: If you use a wireless computer to configure WEP settings, you will be disconnected when you click Apply. Reconfigure your wireless adapter to match the new settings or access the wireless access point from a wired computer to make any further changes.

Configuring WPA with RADIUS

Not all wireless adapters support WPA. Furthermore, client software is required on the client. Windows XP and Windows 2000 with Service Pack 3 or above do include the client software that supports WPA. Nevertheless, the wireless adapter hardware and driver must also support WPA. Consult the product document for your wireless adapter and WPA client software for instructions on configuring WPA settings.

To configure WPA, follow these steps:

1. Under the **Configuration** tab, select **Security** on the main menu, select **Advanced** from the left-hand menu, and then select **RADIUS Server Settings**. The RADIUS Server Settings screen displays.
2. Enter the RADIUS Server Settings as shown in [“Configuring the RADIUS Server Settings” on page 3-9](#).
3. Click **Apply** to save your RADIUS Server settings.

- Under the **Configuration** tab, select **Security** from the main menu. The screen for the Edit Security Profile displays.

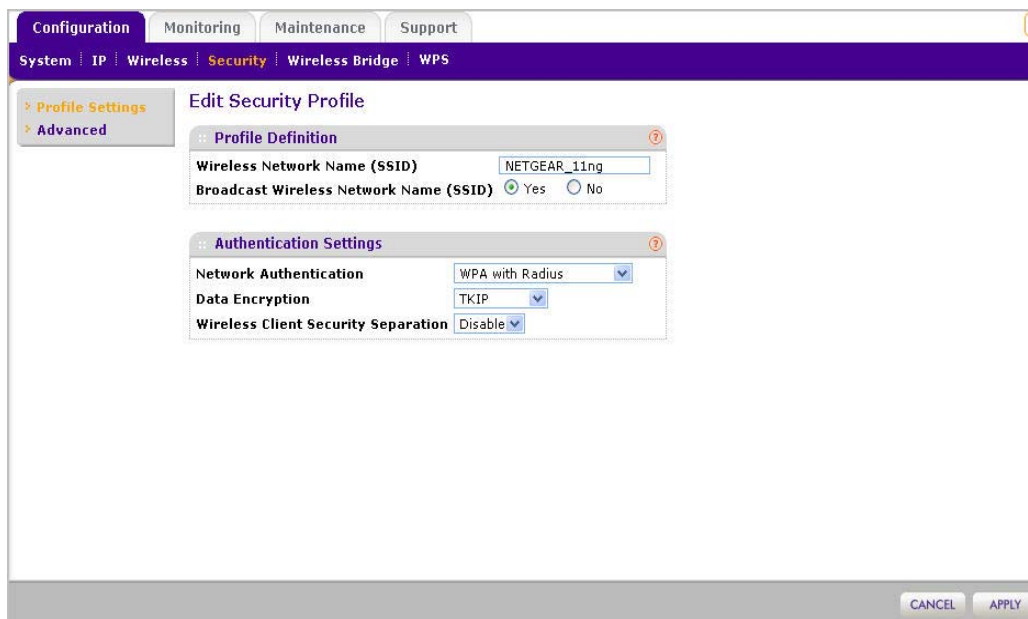

Figure 3-10 Configure WPA with RADIUS

- Choose **WPA with RADIUS** from the from the Network Authentication drop-down menu. Data Encryption will be set to TKIP by default.
- Wireless Client Security Separation** is disabled by default. If enabled, associated wireless clients will not be able to communicate with each other. (This feature is intended for hotspots and other public access situations.)
- Click **Apply** to save your settings.

Configuring WPA2 with RADIUS

Not all wireless adapters support WPA2. Furthermore, client software is required on the client. Make sure your client card supports WPA2. Consult the product document for your wireless adapter and WPA2 client software for instructions on configuring WPA2 settings.

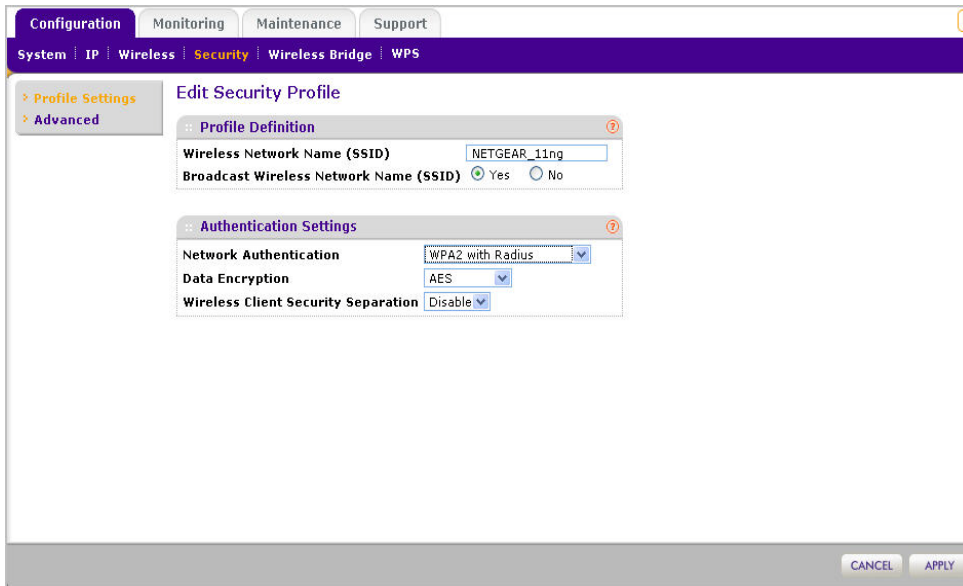

Figure 3-11 Configure WPA2 with RADIUS

To configure WPA2 with RADIUS:

1. Under the **Configuration** tab, select **Security** on the main menu, select **Advanced** from the left panel, and then select **RADIUS Server Settings**. The RADIUS Server Settings screen displays.
2. Enter the RADIUS settings as shown in [“Configuring the RADIUS Server Settings” on page 3-9](#).
3. Click **Apply** to save your RADIUS settings.
4. Under the **Configuration** tab, select **Security** from the main menu The screen for Edit Security Profile displays.
5. From the Network Authentication drop-down menu, select WPA2 with RADIUS from the list. By default, Data Encryption will be set to **AES**.

6. **Wireless Client Security Separation** is disabled by default. If enabled, associated wireless clients will not be able to communicate with each other. (This feature is intended for hotspots and other public access situations.)
7. Click **Apply** to save your settings.

Configuring WPA and WPA2 with RADIUS

Not all wireless adapters support WPA and WPA2. Client software is required on the client:

- Windows XP and Windows 2000 with Service Pack 3, or above, do include the client software that supports WPA. The wireless adapter hardware and driver must also support WPA.
- Service Pack 3 does not include the client software that supports WPA2. Make sure your client card supports WPA2. The wireless adapter hardware and driver must also support WPA2.

Consult the product documentation for your wireless adapter; WPA client software for instructions on configuring WPA settings; and WPA2 client software for instructions on configuring WPA2 settings.

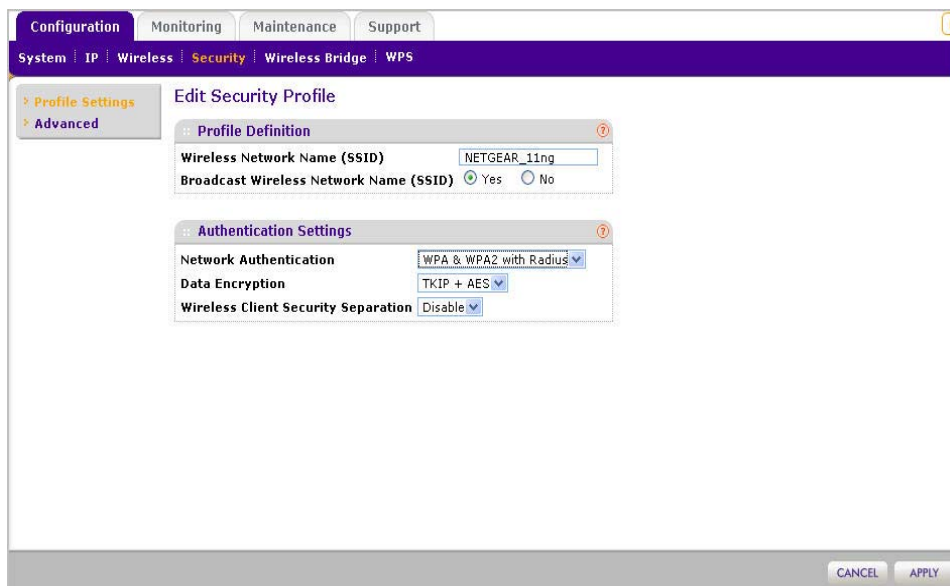

Figure 3-12 Configure WPA and WPA2 with RADIUS

To configure WPA and WPA2 with RADIUS:

1. Under the **Configuration** tab, select **Security** on the main menu, select **Advanced** from the left panel, and then select **RADIUS Server Settings**. The RADIUS Server Settings screen displays.
2. Enter the RADIUS settings as shown in [“Configuring the RADIUS Server Settings” on page 3-9](#).
3. Click **Apply** to save your RADIUS settings
4. Under the **Configuration** tab, select **Security** from the main menu. The screen for Edit Security Profile displays.
5. From the **Network Authentication** drop-down menu, select **WPA & WPA2 with RADIUS** from the list. By default, **Data Encryption** will be set to **TKIP+AES**.
6. **Wireless Client Security Separation** is disabled by default. If enabled, associated wireless clients will not be able to communicate with each other. (This feature is intended for hotspots and other public access situations.
7. Click **Apply** to save your settings.

Configuring WPA-PSK

Not all wireless adapters support WPA. Furthermore, client software is required on the client. Windows XP and Windows 2000 with Service Pack 3 or above include the client software that supports WPA. Nevertheless, the wireless adapter hardware and driver must also support WPA. Consult the product document for your wireless adapter and WPA client software for instructions on configuring WPA settings.

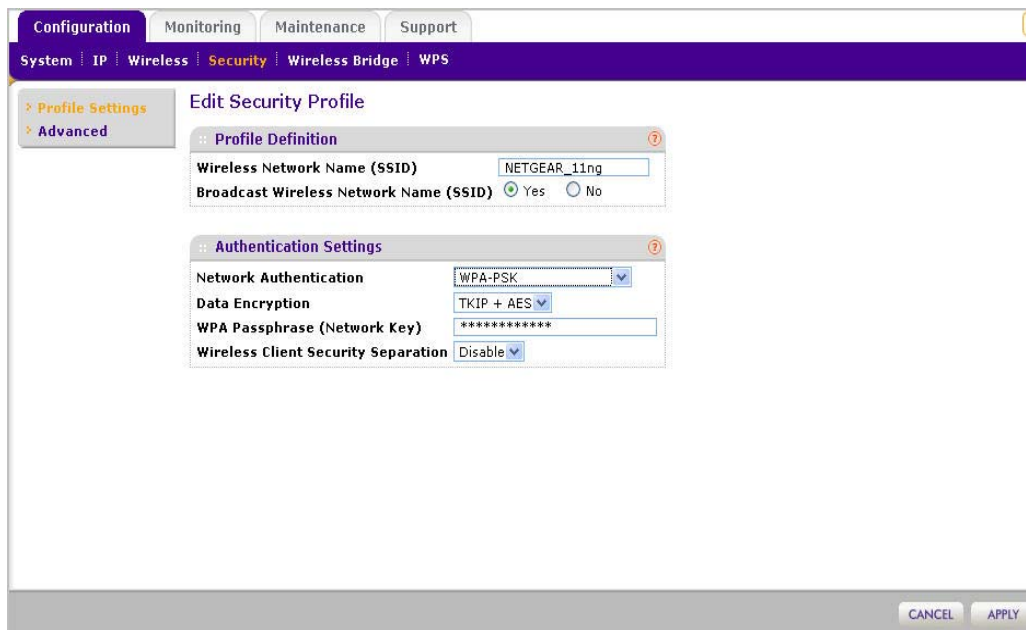

Figure 3-13 Configure WPA-PSK

To configure WPA-PSK:

1. From the **Network Authentication** drop-down menu, select **WPA-PSK**. By default, **Data Encryption** will be set to **TKIP**.
2. Enter the preshared key passphrase (Network Key).
3. **Wireless Client Security Separation** is disabled by default. If enabled, associated wireless clients will not be able to communicate with each other. (This feature is intended for hotspots and other public access situations).
4. Click **Apply** to save your settings.

Configuring WPA2-PSK

Not all wireless adapters support WPA2. Furthermore, client software is required on the client. Make sure your client card supports WPA2. Consult the product document for your wireless adapter and WPA2 client software for instructions on configuring WPA2 settings.

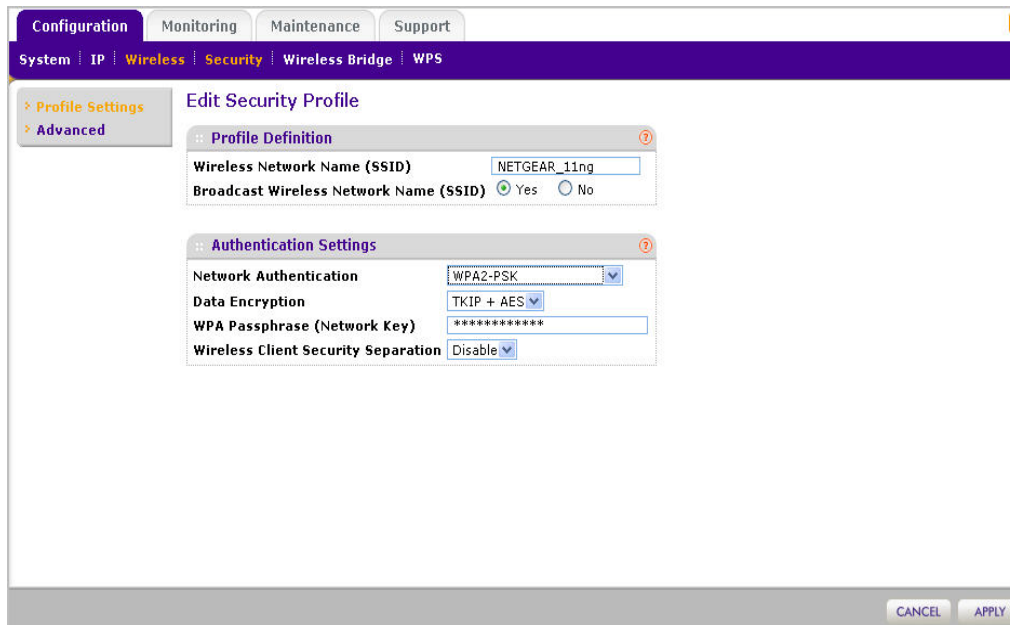

Figure 3-14 Configure WPA2-PSK

To configure WPA2-PSK:

1. From the **Network Authentication** drop-down menu, select **WPA2-PSK** from the list. By default, **Data Encryption** will be set to **AES**.
2. Enter the preshared key passphrase (Network Key).
3. **Wireless Client Security Separation** is disabled by default. If enabled, associated wireless clients will not be able to communicate with each other. (This feature is intended for hotspots and other public access situations).
4. Click **Apply** to save your settings.

Configuring WPA-PSK and WPA2-PSK

Not all wireless adapters support WPA and WPA2. Client software is required on the client:

- Windows XP and Windows 2000 with Service Pack 3 or above do include the client software that supports WPA. The wireless adapter hardware and driver must also support WPA.
- Service Pack 3 does not include the client software that supports WPA2. Make sure your client card supports WPA2. The wireless adapter hardware and driver must also support WPA2.

Consult the product documentation for your wireless adapter; WPA client software for instructions on configuring WPA settings; and WPA2 client software for instructions on configuring WPA2 settings

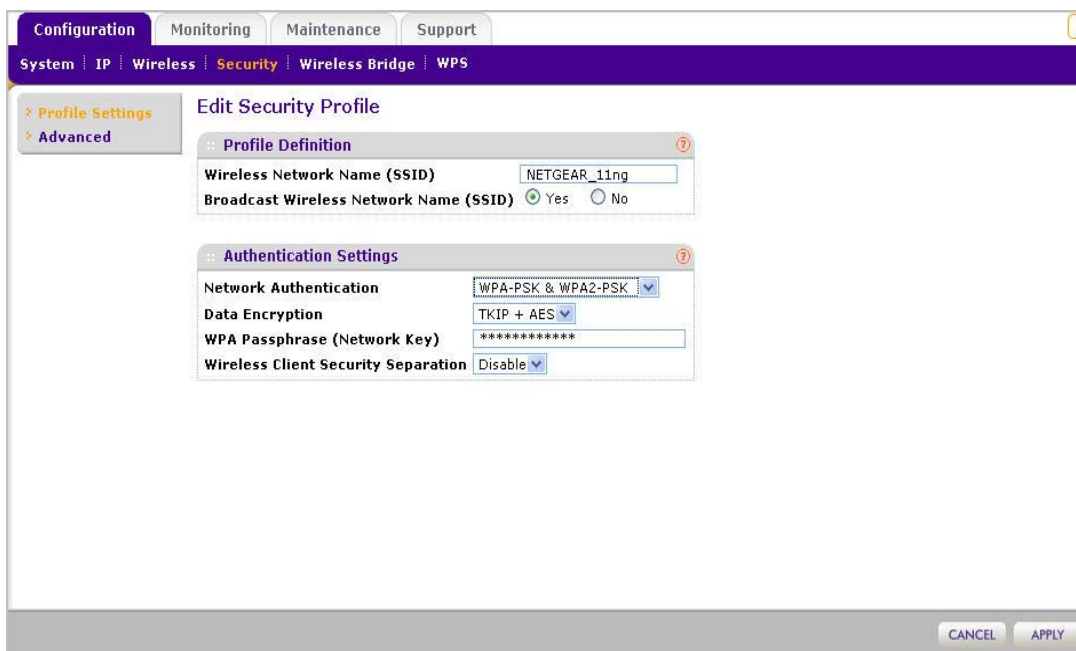

Figure 3-15 Configure WPA-PSK and WPA2-PSK

To configure WPA-PSK and WPA2-PSK:

1. From the **Network Authentication** drop-down menu, select **WPA-PSK & WPA2-PSK**. By default, **Data Encryption** will be set to **TKIP+AES**.
2. Enter the WPA Passphrase (Network Key).
3. **Wireless Client Security Separation** is disabled by default. If enabled, associated wireless clients will not be able to communicate with each other. (This feature is intended for hotspots and other public access situations).

4. Click **Apply** to save your settings.

Restricting Wireless Access by MAC Address

The optional Access Control window lets you block the network access privilege of any specified stations through the WN604 Wireless Access Point. When you enable access control, the access point only accepts connections from clients on the selected access control list. This provides an additional layer of security.



Note: If configuring the WN604 from a wireless computer whose MAC address is not in the access control list, if you select Turn Access Control On, you will lose your wireless connection when you click **Apply**. You must then access the wireless access point from a wired computer or from a wireless computer that is on the access control list to make any further changes.

To restrict access based on MAC addresses:

1. Log in to the WN604 using the default address of <http://192.168.0.100>, user name of **admin** and default password of **password**, or whatever LAN address and password you have set up.
2. Under the **Configuration** tab, select **Security** on the main menu, select **Advanced** from the left panel, and then select **MAC Authentication**. The MAC Authentication screen displays.

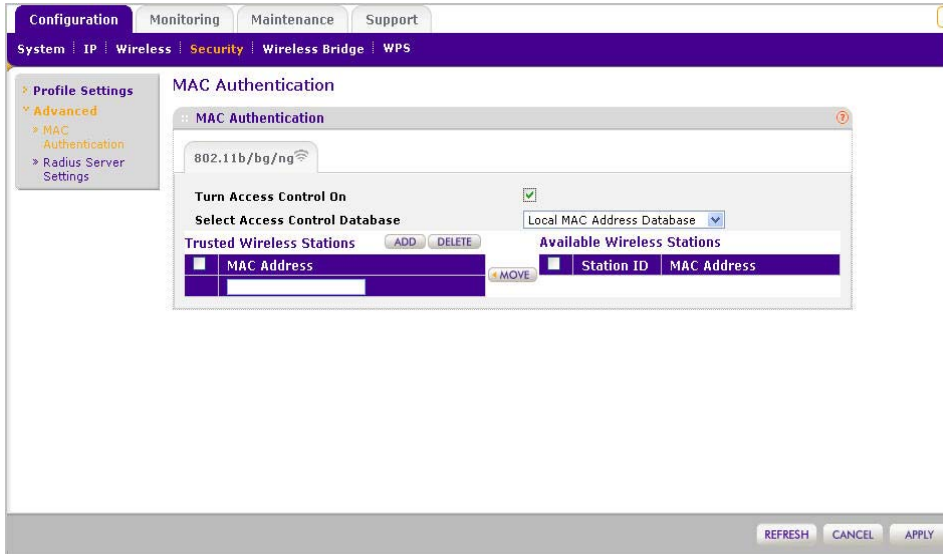

Figure 3-16 Configure MAC authentication

3. Check the **Turn Access Control On** radio box to enable Access Control feature.
4. Select the desired Access Control Database options. The options are:
 - **Local MAC Address Database** – The Access Point will use the local MAC address table for Access Control. This is the default.
 - **RADIUS MAC Address Database** – The Access Point will use the MAC address table located on the external RADIUS server on the LAN for Access Control. If you choose this database, you must configure the RADIUS Server Settings first (see [“Configuring the RADIUS Server Settings”](#) on page 3-9).
5. The **Trusted Wireless Stations** list shows any wireless stations you have entered. If you have not entered any wireless stations this list will be empty. To delete an existing entry, select it and then click **Delete**.
6. Click Refresh to refresh the **Available Wireless Stations** list found in your area.
7. Select the stations from the list of **Available Wireless Stations** found in your area, or enter the MAC address of a station to add a new station manually. (You can usually find the MAC address printed on the bottom of the wireless adapter.)

8. Click **Add** to add the wireless device to the **Trusted Wireless Stations** list. Repeat these steps for each additional device you want to add to the list.
9. Click **Apply** to save your wireless access control list settings.

Now, only devices on this list will be allowed to wirelessly connect to the WN604.

Chapter 4

Management

This chapter describes how to use the management features of your NETGEAR Wireless N150 Access Point WN604. To access these features, connect to the WN604 as described in [“Logging In Using the Default IP Address”](#) on page 2-11. Then select the category under either the **Monitoring** or **Maintenance** headings in the main menu of the browser interface.

This chapter contains the following sections:

1. [“Upgrading the Wireless Access Point Software”](#)
2. [“Configuration File Management”](#)
3. [“Restoring the WN604 to the Factory Default Settings”](#)
4. [“Changing the Administrator Password”](#)
5. [“Enabling the SysLog Server”](#)
6. [“Using Activity Log Information”](#)
7. [“Viewing General Summary Information”](#)
8. [“Viewing Network Traffic Statistics”](#)
9. [“Viewing Available Wireless Station Statistics”](#)

Upgrading the Wireless Access Point Software

The software of the WN604 Wireless Access Point is stored in FLASH memory, and can be upgraded as new software is released by NETGEAR. Upgrade files can be downloaded from Netgear's Web site.. The upgrade file can be sent to the wireless access point using your browser.



Note: The Web browser used to upload new firmware into the WN604 must support HTTP uploads, such as Microsoft Internet Explorer 6.0 or above or Mozilla 1.5 or above.

You cannot perform the software upgrade from a computer that is connected to the WN604 Wireless Access Point with a wireless link. You must use a computer that is connected to the WN604 Wireless Access Point with a Ethernet cable.

	<p>Warning: When uploading software to the WN604 Wireless Access Point, it is important not to interrupt the Web browser by closing the window, clicking a link, or loading a new page. If the browser is interrupted, the upload may fail, corrupt the software, and render the WN604 completely inoperable.</p>
-----------------------------------------------------------------------------------	--------------------------------------------------------------------------------------------------------------------------------------------------------------------------------------------------------------------------------------------------------------------------------------------------------------------------

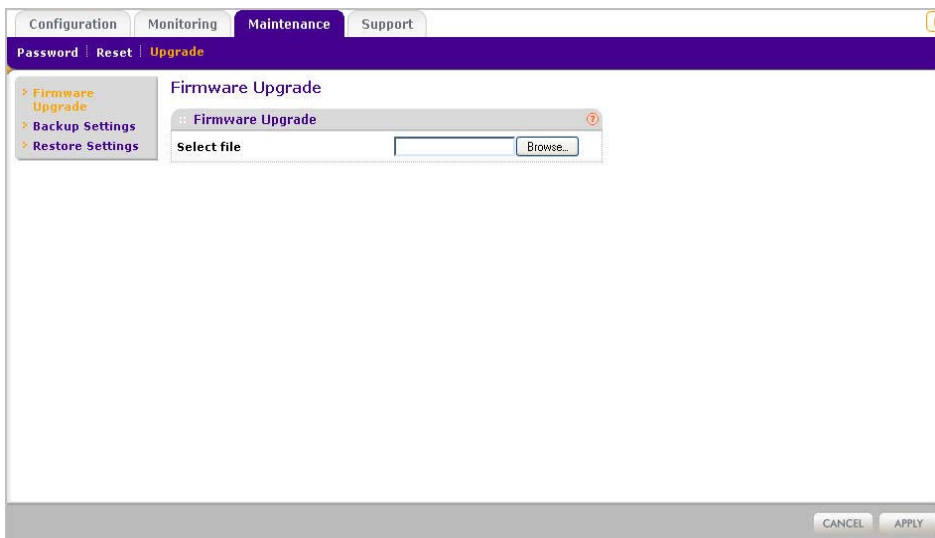

Figure 4-1 Firmware upgrade screen

To upgrade the WN604 firmware:

1. Download the new software file from the NETGEAR website, save it to your hard disk.
2. Under the **Maintenance** tab, select **Upgrade** from the main menu, and then select **Firmware Upgrade**. The Firmware Upgrade screen displays as shown in [Figure 4-1](#) above.
3. Click **Browse** and browse to the location of the upgrade file.
4. Click **Apply**.

When the upload completes, your wireless access point will automatically restart. The upgrade process typically takes about 2 minutes.

Configuration File Management

The WN604 Wireless Access Point settings are stored in the wireless access point in a configuration file. This file can be saved (backed up) to a user's computer, retrieved (restored) from the user's computer, or cleared to factory default settings.

Saving Your Configuration Settings

Under the **Maintenance** tab on the main menu, select **Upgrade**, then select **Backup Settings** from the left sidebar to back up your current settings. The following screen displays:

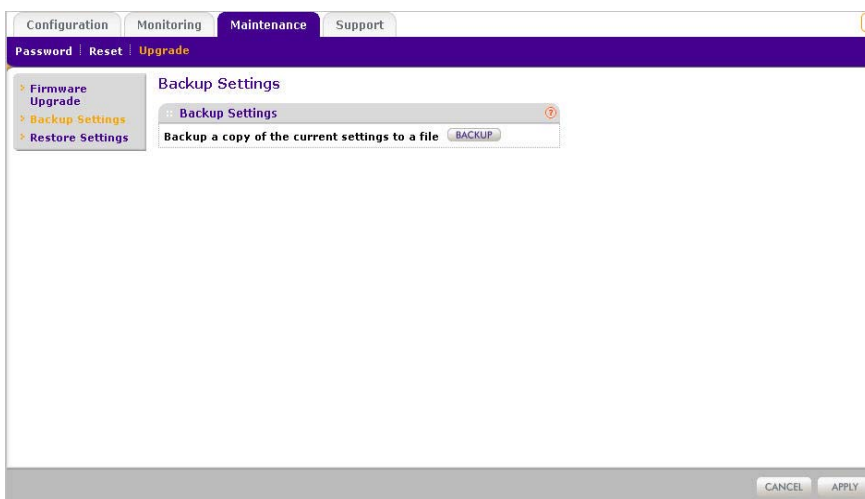

Figure 4-2 Backup configuration settings

1. Click **Backup**. Your browser will extract the configuration settings from the wireless access point and prompt you for a location on your computer to store the file.
2. Give the file a meaningful name, such as `WN604.cfg`, and click **Save**.

Restoring Saved Settings

Under the **Maintenance** tab on the main menu, select **Upgrade**, then select **Restore Settings** from the sidebar to back up your current settings. The following screen displays:

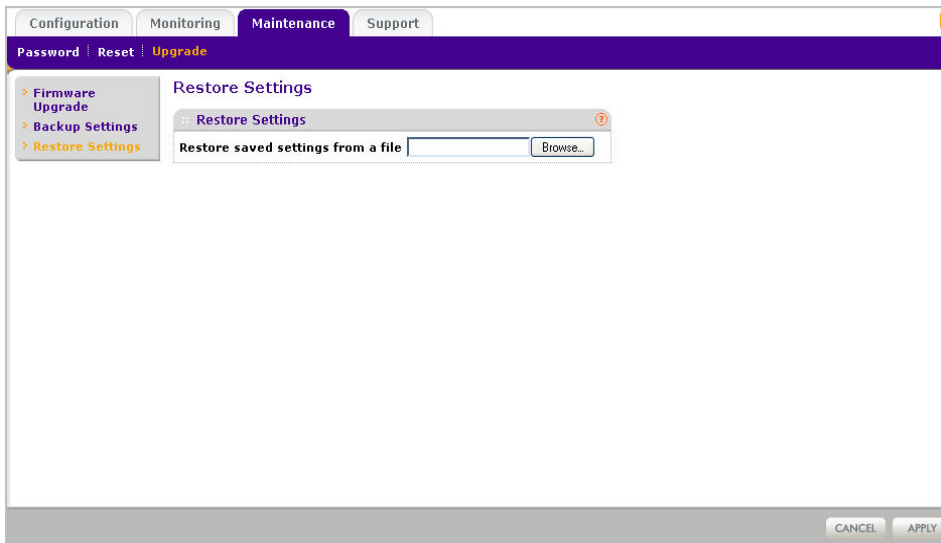

Figure 4-3 Restore Configuration settings from file

1. Enter the full path to the backup file on your computer (see previous section) or click the **Browse** button to locate the file.
2. When you have located the file, click **Restore** to upload the file. After completing the upload, the WN604 will reboot automatically.

Restoring the WN604 to the Factory Default Settings

It is sometimes desirable to restore the wireless access point to the factory default settings. This can be done by using the **Restore Defaults** option, which restores all factory settings.

To access this function:

1. Under the **Maintenance** tab on the main menu, select **Reset**, and then select **Restore Defaults** from the sidebar. The Restore Defaults screen displays, as shown in [Figure 4-4](#) below.

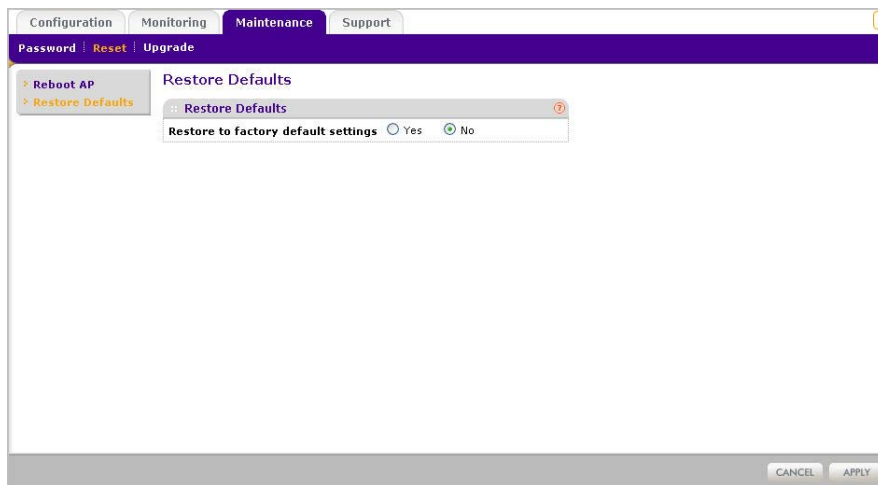

Figure 4-4 Restore to factory defaults

2. On the Restore Defaults screen, enable the **Restore to factory default settings** option by selecting the **Yes** radio button.
3. Click **Apply** to reset to the factory default settings.

After a restore, the wireless access point password will be **password**, the default LAN IP address will be **192.168.0.100**, and the access point name will reset to the name printed on the label on the bottom of the unit.

To restore the factory default configuration settings without knowing the login password or IP address, you must use the Default Reset button on the rear panel of the wireless access point (see [Figure 1-1 on page 1-6](#)). The reset button has two functions:

- **Reboot.** When pressed and released, the Wireless Access Point will reboot (restart).
- **Reset to Factory Defaults.** This button can also be used to clear all data and restore all settings to the factory default values.

To clear all data and restore the factory default values:

1. Power off the WN604.
2. Use something with a small point, such as a pen, hold the Reset button for 5 seconds while you Power On the WN604.
3. Continue holding the Reset Button until the LEDs blink twice.

4. Release the Reset Button.

The factory default configuration has now been restored and the WN604 is ready for use.

Changing the Administrator Password

The default password is **password**. You should change this password to a more secure password, since you cannot change the administrator login name.

To change the Administrator password:

1. Under the **Maintenance** tab on the main menu, select **Password**, and then select **Change Password**. The Change Password screen displays as shown in [Figure 4-5](#) below.

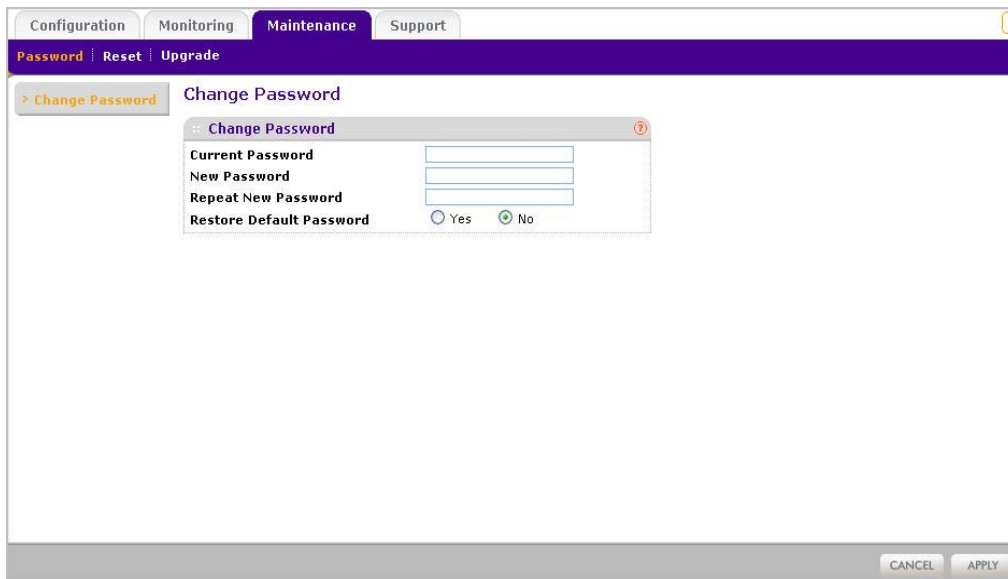

The screenshot shows the Netgear web interface with the 'Maintenance' tab selected. The 'Password' sub-tab is active, and the 'Change Password' option is highlighted. The 'Change Password' dialog box contains the following fields and options:

Change Password	
Current Password	<input type="text"/>
New Password	<input type="text"/>
Repeat New Password	<input type="text"/>
Restore Default Password	<input type="radio"/> Yes <input checked="" type="radio"/> No

At the bottom right of the dialog box, there are 'CANCEL' and 'APPLY' buttons.

Figure 4-5 Change administrator password

2. First enter the old password in the **Current Password** field.
3. Then enter the new password twice—once in the **New Password** field and again in the **Repeat New Password** field.
4. Click **Apply** to save your change.

Enabling the SysLog Server

The SysLog screen allows you to enable the SysLog option if you have a SysLog server on your LAN.

To enable a SysLog server:

1. Under the **Configuration** tab on the main menu, select **System**, then select the **Advanced** option, and select **SysLog** to view the screen shown in [Figure 4-6](#).

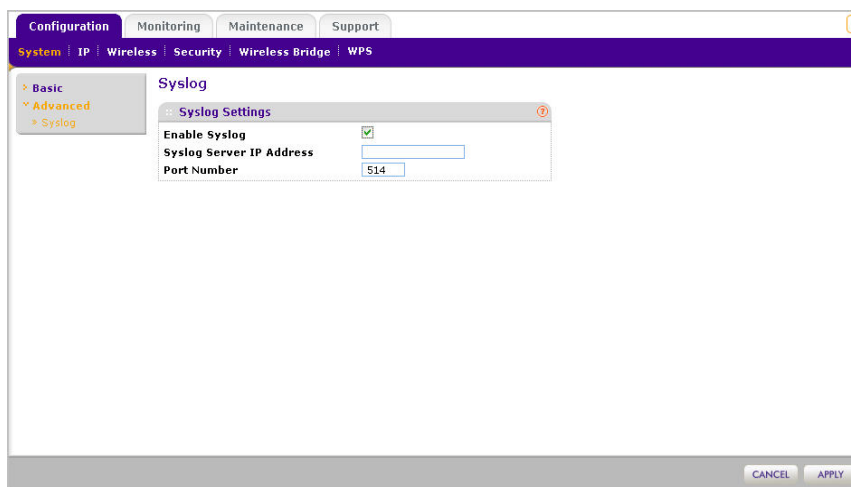

Figure 4-6 Enable Syslog server

2. **Enable SysLog** – Enable this option if you have a SysLog server on your LAN. If enabled, you must enter the IP address of your SysLog server and the port number your SysLog server is configured to use. The default is Disabled.
3. **SysLog Server IP Address** –The access point will send all the SysLog to the specified IP address if SysLog option is enabled.
4. **Port Number** – The port number configured in the SysLog server on your LAN. Default is 514.
5. Click **Apply** to save your Syslog settings.

Using Activity Log Information

The Activity Log screen displays the Access Point system activity.

To view the Activity Log, under the **Monitoring** tab on the main menu, click **Logs**. The Activity Logs screen displays as shown in [Figure 4-7](#) below.

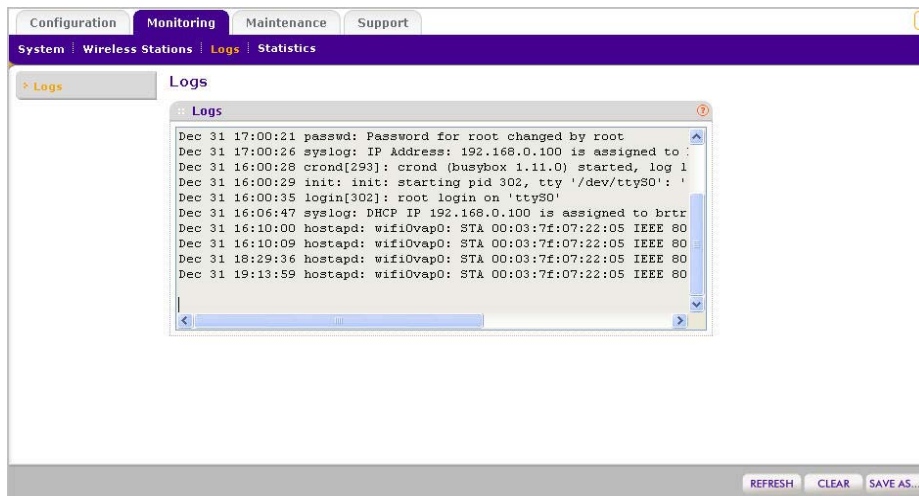

Figure 4-7 View activity logs

The Activity Log Window displays the Access Point system activity.

Click **Refresh** to update the display, click **Clear** to clear the log content, or click **Save As** to save the log contents into a file on a disk drive.

Viewing General Summary Information

The System screen, under the **Monitoring** tab provides a summary of the current WN604 configuration settings, including current IP settings and current Wireless settings. This information is read only, so any changes must be made on other pages.

To access the System screen:

Under the **Monitoring** tab on the main menu, select **System** to view the System screen, shown in [Figure 4-8](#) below. This screen shows the parameters listed in [Table 4-1](#):

Table 4-1. System Information Fields

Field	Description
Access Point Information	
Access Point Name	Indicates the NetBIOS name. The default name may be changed, if desired.
Ethernet MAC Address	Displays the Media Access Control address (MAC address) of the wireless access point's Ethernet port.
Wireless MAC address.	Displays the Media Access Control address (MAC address) of the wireless access point's wireless card.
Country/Region	Displays the domain or region for which the wireless access point is licensed for use. It may not be legal to operate this wireless access point in a region other than one of those identified in this field.
Firmware Version	The version of the firmware currently installed.
Current Time	Displays the current system time of the access point.
Current IP Settings	
IP Address	The IP address of the wireless access point.
Subnet Mask	The subnet mask for IP address of the wireless access point.
Default Gateway	The default gateway for the wireless access point communication.
DHCP Client	Enabled indicates that the current IP address of the AP was obtained from a DHCP server on your network. Disabled indicated a static IP configuration.
Current Wireless Settings for 802.11b/bg/ng	
Operating Mode	Identifies the 802.11 operating mode of the WN604.
Channel/Frequency	Identifies the channel the wireless port is using. 'Auto' is the default channel setting. (Channel frequencies used on each channel can be found in "Wireless Communications"; a link to this article is in Appendix B, "Related Documents").

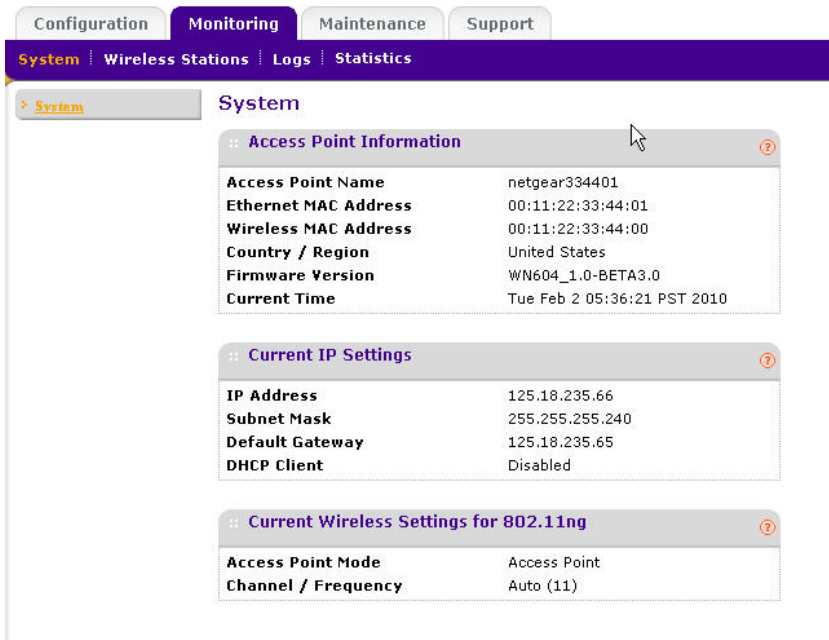

The screenshot shows the Netgear web interface with the **Monitoring** tab selected. The **System** section is expanded, displaying three panels of information:

- Access Point Information**

Access Point Name	netgear334401
Ethernet MAC Address	00:11:22:33:44:01
Wireless MAC Address	00:11:22:33:44:00
Country / Region	United States
Firmware Version	WN604_1.0-BETA3.0
Current Time	Tue Feb 2 05:36:21 PST 2010
- Current IP Settings**

IP Address	125.18.235.66
Subnet Mask	255.255.255.240
Default Gateway	125.18.235.65
DHCP Client	Disabled
- Current Wireless Settings for 802.11ng**

Access Point Mode	Access Point
Channel / Frequency	Auto (11)

Figure 4-8 View system information

Viewing Network Traffic Statistics

The Statistics screen displays information for both wired (LAN) and wireless (WLAN) interface network traffic.

To access Statistics information:

1. Under the **Monitoring** tab on the main menu, select **Statistics**. The Statistics screen displays, as shown in [Figure 4-9](#) below.

Statistics		
:: Wired Ethernet		
	Received	Transmitted
Packets	0	0
Bytes	0	0
:: Wireless 802.11ng		
	Received	Transmitted
Unicast Packets	0	0
Broadcast Packets	0	20
Multicast Packets	0	12
Total Packets	0	32
Total Bytes	0	5275

Figure 4-9 View network statistics

- Click **Refresh** to update the Statistics information for each interface. .

Table 4-2, shown below, describes the information fields detailed on the Statistics screen.

Table 4-2. Statistics Fields

Field	Description
Wired Ethernet	
Packets	The number of packets sent and received since the WN604 was restarted.
Bytes	The number of bytes sent and received since the WN604 was restarted.
Wireless 11b/bg/ng	
Unicast Packets	The Unicast packets sent and received in 802.11n/g mode since the WN604 was restarted.
Broadcast Packets	The Broadcast packets sent and received in 802.11n/g mode since the WN604 was restarted.
Multicast Packets	The Multicast packets sent and received in 802.11n/g mode since the WN604 was restarted.

Table 4-2. Statistics Fields

Field	Description
Total Packets	The Wireless packets sent and received in 802.11n/g mode since the WN604 was restarted.
Total Bytes	The Wireless bytes sent and received in 802.11n/g mode since the WN604 was restarted.

Viewing Available Wireless Station Statistics

The Available Wireless Stations List (AWSL) contains a table of all IP devices associated with this wireless access point in the wireless network defined by the Wireless Network Name (SSID). For each device, the table shows the MAC address, BSSID, SSID, Channel, Rate, State (whether the device is allowed to communicate with the wireless access point or not), Type, AID, Mode, and Status.



Note: A wireless network can include multiple wireless access points, all using the same network name (SSID). This enables extending the reach of the wireless network and allows users to roam from one access point to another, providing seamless network connectivity. Under these circumstances, be aware that only the stations associated with this access point will be presented in the Available Station List.

To view the Available Wireless Stations List:

1. Under the **Monitoring** tab, select **Wireless Stations** on the main menu. The Available Wireless Stations list displays, as shown in [Figure 4-10](#).

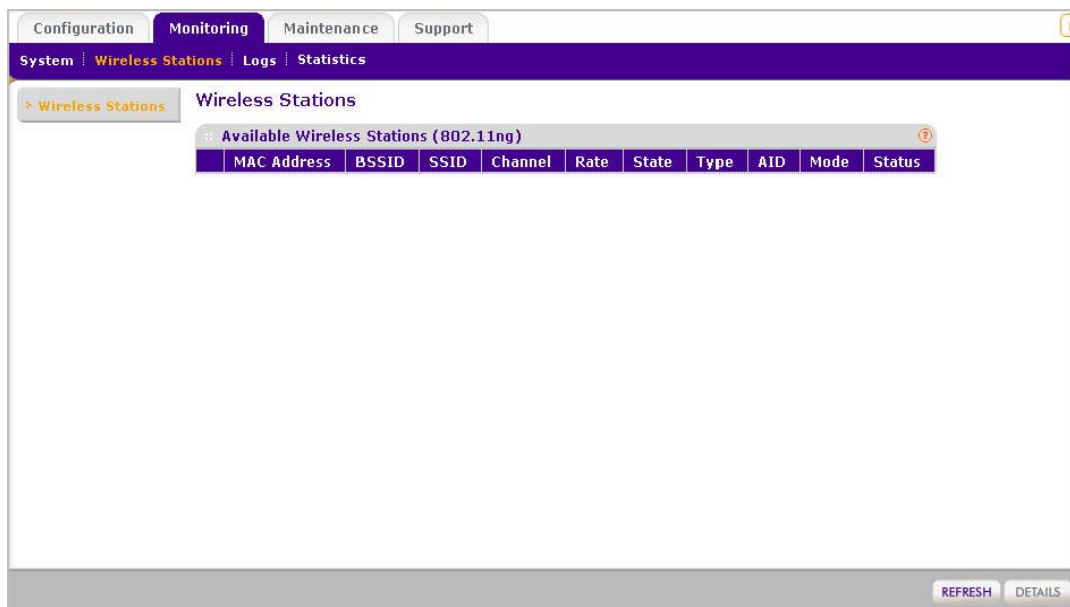

Figure 4-10 Available Wireless Stations list

2. Click **Refresh** to update the list.



Tip: If the wireless access point is rebooted, the table data is lost until the wireless access point rediscovers the devices. To force the wireless access point to look for associated devices, click the **Refresh** button.

Chapter 5

Advanced Configuration

This chapter describes how to configure the advanced features of your NETGEAR Wireless N150 Access Point WN604. The advanced configuration features are located under various sub-menus under **Configuration** and provide the following functions:

- **Scheduled Wireless:** Configuring Scheduled Wireless ON/OFF parameters (“[Configuring Scheduled Wireless](#)”)
- **Wireless Settings:** Configuring advanced wireless LAN parameters (“[Configuring Advanced Wireless Settings](#)”).
- **Advanced QoS Settings:** Configuring advanced QoS settings (“[Configuring Advanced QoS Settings](#)”)
- **Access Point Settings:** Enabling wireless bridge and repeater modes (“[Enabling Wireless Bridging](#)”).

Configuring Scheduled Wireless

The WN604 Wireless Access Point allows you to schedule wireless ON/OFF for any day(s) of the week, from an ON time to an OFF time. Click **Configuration > Wireless > Scheduled Wireless ON-OFF**.

This feature depends on the NTP (Network Time Protocol) functionality. If an NTP client request fails, then last configured value of radio status by user will be restored. Also, if RF is disabled then scheduled wireless functionality will not work.

Click **Wireless > Basic > Scheduled Wireless ON/OFF** on the main menu. The Scheduled Wireless ON/OFF screen displays.

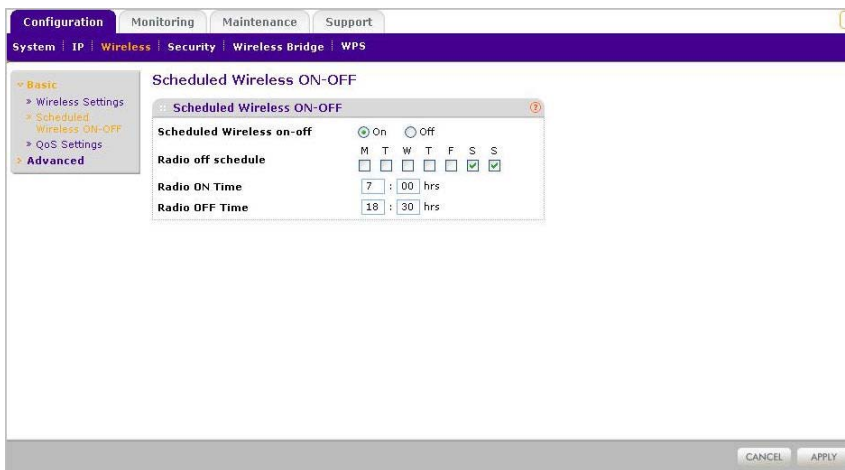

Figure 5-1

Follow the steps below to schedule wireless on your WN604:

1. Enable **Scheduled Wireless ON/OFF** by clicking the **On** radio button. The default is On.
2. **Radio Off Schedule:** Click any of the weekday checkboxes to set the WN604's radio off on that weekday(s).
3. Enter the **Radio ON Time** and **Radio OFF Time** to set the period that the WN604's radio will be enabled on the days not checked in the previous option. The default is ON for the whole day.
4. Click **Apply**.

Configuring Advanced Wireless Settings

The **Advanced** option of the Wireless Settings menu is used to configure and enable various wireless LAN parameters for the 802.11b/bg/ng modes. The default wireless LAN parameters usually work well. However, you can use these settings to fine tune the overall performance of your wireless access point for your environment.

The Wireless Settings option of the Advanced menu is used to configure the Wireless LAN parameters. The default advanced wireless LAN parameter settings usually work well.

Configuring 802.11b/bg/ng Advanced Wireless Settings

To configure advanced Wireless Settings:

1. Under the **Configuration** tab, select **Wireless**.
2. From the sidebar, select **Advanced**, and then select **Wireless Settings**.
3. The Advanced Wireless Settings screen you selected displays, as shown in [Figure 5-2](#).

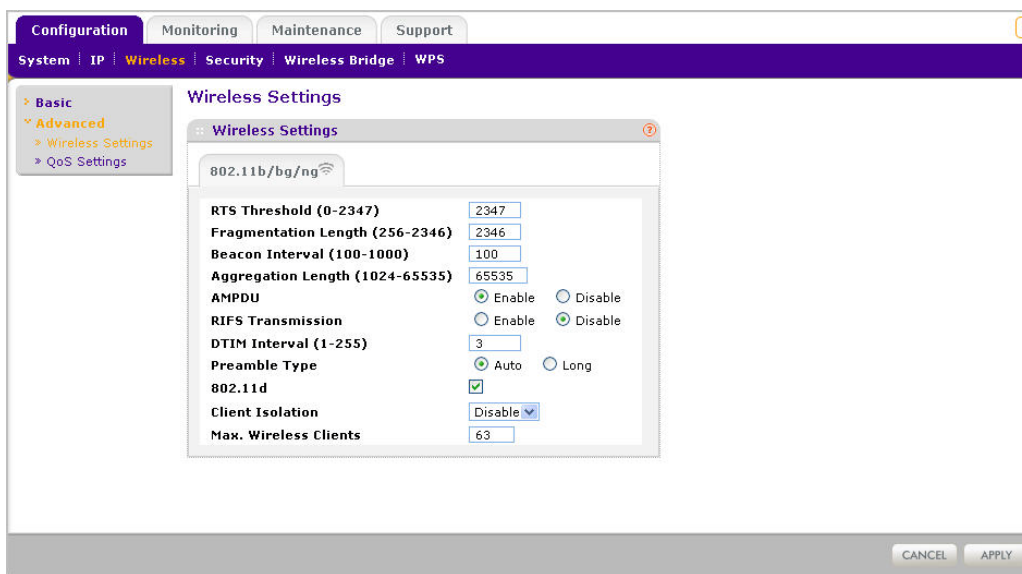

Figure 5-2 Advanced Wireless Settings - 802.11b/bg/ng

4. Enter the appropriate information in the fields described below:
 - **RTS Threshold (0 - 2347):** Request to Send Threshold. The packet size that is used to determine if it should use the CSMA/CD (Carrier Sense Multiple Access with Collision Detection) mechanism or the CSMA/CA mechanism for packet transmission. With the CSMA/CD transmission mechanism, the transmitting station sends out the actual packet as soon as it has waited for the silence period. With the CSMA/CA transmission mechanism, the transmitting station sends out an RTS packet to the receiving station, and waits for the receiving station to send back a CTS (Clear to Send) packet before sending the actual packet data. The default is 2347.

- **Fragmentation Length (256 - 2346):** This is the maximum packet size used for fragmentation. Packets larger than the size programmed in this field will be fragmented. The Fragmentation threshold value must be larger than the RTS threshold value. The default is 2346.
- **Beacon Interval (100 - 1000):** The Beacon Interval. Specifies the interval time between 100ms and 1000ms for each beacon transmission, which allows the access point to synchronize the wireless network. The default is 100.
- **Aggregation Length (1024-65535) (11ng):** The aggregation length defines the size of aggregated packets. Larger aggregation lengths may sometimes lead to better network performance. The default is 65535.
- **A-MPDU (11ng):** Aggregated MAC Protocol Data Unit. Aggregates several MAC frames into a single large frame to achieve higher throughput. The default is enabled.
- **RIFS Transmission (11ng):** Reduced Interframe Space. RIFS transmissions are shorter than other interframe spaces, and if enabled allow transmission of successive frames at different transmit powers. The default is disabled.
- **DTIM Interval:** The Delivery Traffic Indication Message. Specifies the data beacon rate between 1 and 255. The default is 3.
- **Preamble Type (11b/bg only):** A long transmit preamble may provide a more reliable connection or a slightly longer range. A short transmit preamble gives better performance. The Auto settings automatically handles both long and short preambles. The default is Auto.
- **802.11d:** Enable this option to include support for "additional regulatory domains" that are not in the current standard.
- **Max Wireless Clients:** The number of wireless clients that can associate with the AP at one time. The default is 20.

5. Click **Apply** to enable the Wireless Settings.

Configuring Advanced QoS Settings

Wireless Multimedia Extension (WME) or Wi-Fi Multimedia (WMM) is a subset of the 802.11e standard. WME allows wireless traffic to have a range of priorities, depending on the type of data. Time-dependent information, such as video or audio, has a higher priority than normal traffic. For WME to function correctly, Wireless clients must also support WME.

Figure 5-3 shows the Quality of Service (QoS) screen. For most networks, the default QoS queue parameter settings work well. Quality of Service provides you with the ability to specify parameters on multiple queues for increased throughput and better performance of differentiated wireless traffic, like Voice-over-IP (VoIP), other types of audio, video, and streaming media, as well as traditional IP data.

To configure advanced QoS settings, on the **Configuration** tab select **Wireless**, select **Advanced**, and then select **QoS Settings**. The QoS Settings screen displays:

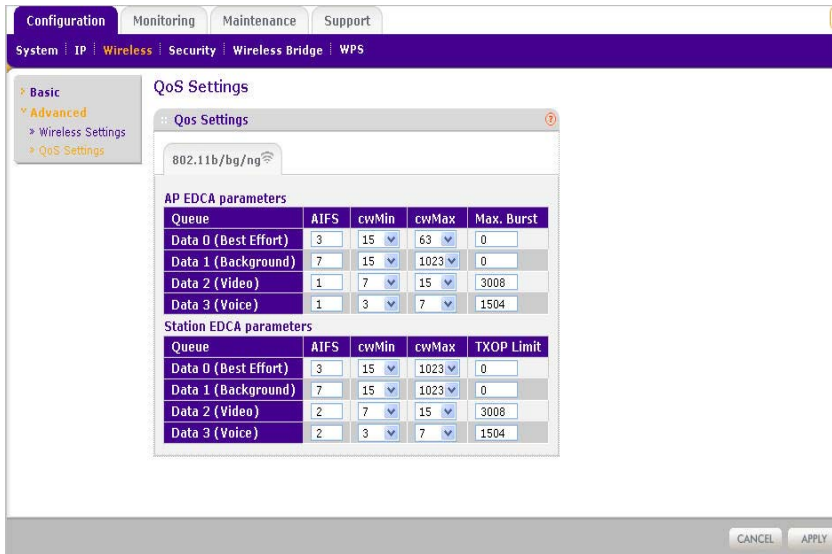

Figure 5-3 Advanced QoS settings

The QoS options on the WN604 are as follows:

- **AP EDCA Parameters.** Specify the AP EDCA (Enhanced Distributed Channel Access) parameters for different types of data transmitted from the WN604 Wireless Access Point to the wireless client.
- **Station EDCA Parameters.** Specify the Station EDCA parameters for different types of data transmitted from the wireless client to the WN604 Wireless Access Point. If WMM is disabled, you cannot configure Station EDCA parameters.

Table 5-1 describes the settings for QoS Queues.

Table 5-1. QoS Queues and Parameters

QoS Queue	Description
Data 0 (Voice)	High priority queue, minimum delay. Time-sensitive data such as VoIP and streaming media are automatically sent to this queue.
Data 1 (Video)	High priority queue, minimum delay. Time-sensitive video data is automatically sent to this queue.
Data 2 (Best Effort)	Medium priority queue, medium throughput and delay. Most traditional IP data is sent to this queue.
Data 3 (Background)	Lowest priority queue, high throughput. Bulk data that requires maximum throughput and is not time-sensitive is sent to this queue (FTP data, for example).
AIFS (Arbitration Inter-Frame Space)	Specifies a wait time (in milliseconds) for data frames. Valid values for AIFS are 1 through 255.
cwMin (Minimum Contention Window)	Upper limit (in milliseconds) of a range from which the initial random backoff wait time is determined. Valid values for the "cwmin" are 1, 3, 7, 15, 31, 63, 127, 255, 511, or 1024. The value for cwMin must be lower than the value for cwMax.
cwMax (Maximum Contention Window)	Upper limit (in milliseconds) for the doubling of the random backoff value. Valid values for the "cwmax" are 1, 3, 7, 15, 31, 63, 127, 255, 511, or 1024. The value for cwMax must be higher than the value for cwMin.
Max. Burst Length	Specifies (in milliseconds) the Maximum Burst Length allowed for packet bursts on the wireless network. A packet burst is a collection of multiple frames transmitted without header information. Valid values for maximum burst length are 0.0 through 999.9.

Enabling Wireless Bridging

The NETGEAR Wireless N150 Access Point WN604 lets you build large bridged wireless networks. Select the desired wireless access point mode for your environment:

- **Wireless Point-to-Point Bridge.** In this mode, the WN604 can communicate with another bridge mode wireless access point, and with wireless clients if enabled.

When you click the **Edit** button, you must enter the Profile Name and the MAC address (physical address) of the other Bridge mode wireless access point in the fields provided (see [Figure 5-5](#) below). WEP, WPA-PSK, or WPA2-PSK are supported. WPA2-PSK can (and should) be used to protect this communication.

- **Wireless Point-to-Multi-Point Bridge.** Select this only if this WN604 is the “Master” for a group of bridge-mode wireless access points.

The other bridge-mode wireless access points must be set to point-to-point bridge mode, using the MAC address of this WN604. They then send all traffic to this “Master”, rather than communicate directly with each other.

When you click the **Edit** button, you must enter the profile name and the MAC address (physical address) of the other bridge mode wireless station in the fields provided (see [Figure 5-5](#) below). WEP, WPA-PSK, or WPA2-PSK are supported. WPA2-PSK can (and should) be used to protect this communication.

The AP can associate with wireless clients if this option is enabled.

- **Client mode.** In this mode the access point acts as a client. It is used to extend the LAN of clients that do not have wireless connectivity

The screens used to configure these options are located by selecting **Wireless Bridge** under the **Configuration** tab.

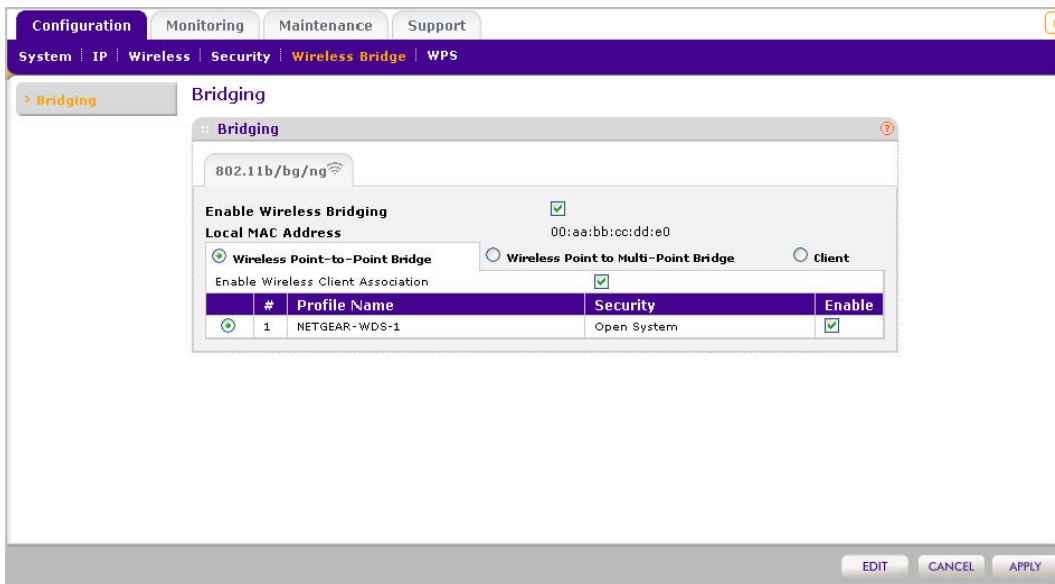

Figure 5-4 Enable Wireless Point-to-Point Bridge

Follow the steps below to configure bridging on your WN604:

1. Click the **Enable Wireless Bridging** checkbox (see Figure 5.4 above).
2. Select one of the following options:

- **Wireless Point to Point Bridge**
 - **Wireless Point to Multipoint Bridge**
 - **Client** mode
3. If you have selected one of the first two options:
 - Select **Enable Wireless Client Association**, if desired.
 - Select the security profile whose settings you wish to edit
 - Click **Edit** to edit the security profile as discussed in the previous sections. The Edit Security Profile screen displays, as shown [Figure 5-5](#) below.
 - Click **Back** to return to the previous screen and enable the profile.
 4. If you have selected **Client**:
 - **MAC Clone**: This option appears only in client mode. Use it to configure a new MAC address on the AP Client if desired.
 - **MAC Clone Address**. If the MAC Clone option has been enabled enter the new MAC address in hexadecimal format. It will be used by the AP client in place of its default physical address.
 5. Click **Apply**.

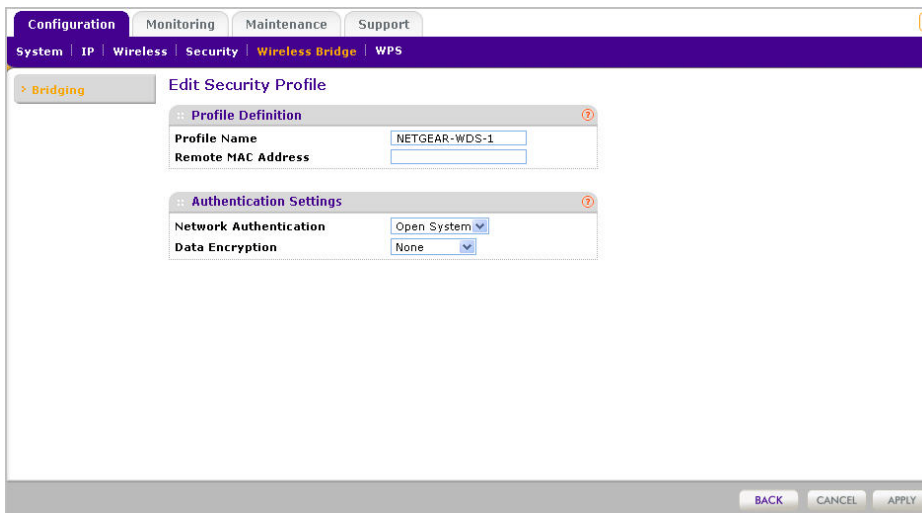

Figure 5-5 Bridging - Edit Security Profile

The following sections help you to physically configure your WN604 as a Point-to-Point Bridge or a Point-to-Multi-Point Bridge.

Configuring a WN604 as a Point-to-Point Bridge

To configure a point-to-point bridge as shown in [Figure 5-6](#):

1. Under the **Configuration** tab, select **Wireless Bridge**. Then, select **Bridging**. The Bridging screen displays (see [Figure 5-4](#)).
2. Configure the WN604 (AP1) on LAN Segment 1 in Point-to-Point Bridge mode.

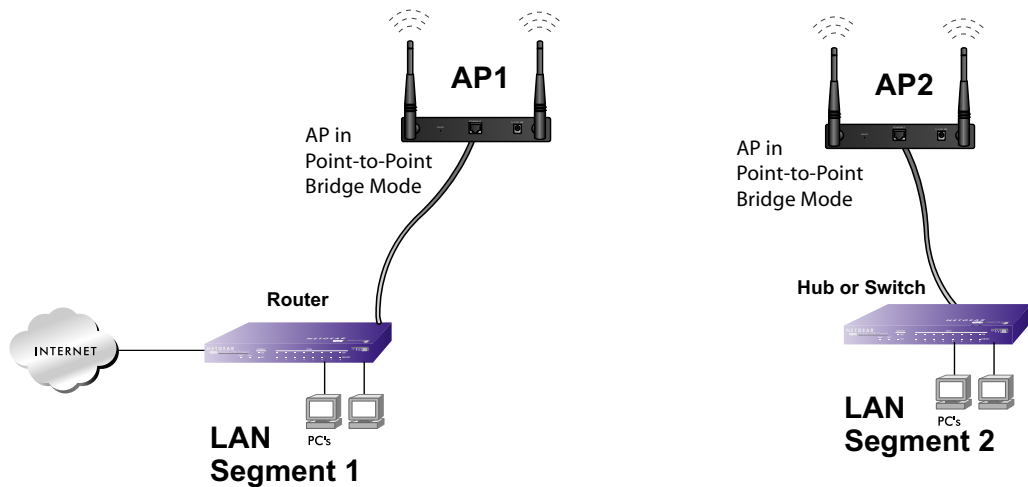

Figure 5-6 Wireless point-to-point bridge setup

3. Configure the WN604 (AP2) on LAN Segment 2 in Point-to-Point Bridge mode.
AP1 must have AP2's MAC address in its Remote MAC Address field and AP2 must have AP1's MAC address in its Remote MAC Address field.
4. Configure and verify the following parameters for both access points:
 - Verify that the LAN network configuration of the WN604 Wireless Access Points both are configured to operate in the same LAN network address range as the LAN devices
 - Both use the same ESSID, Channel, authentication mode, if any, and security settings if security is in use.
5. Verify connectivity across the LAN 1 and LAN 2.

A computer on either LAN segment should be able to connect to the Internet or share files and printers of any other PCs or servers connected to LAN Segment 1 or LAN Segment 2.

- Click **Apply** to save your settings.

Configuring a Point-to-Multi-Point Wireless Bridge

To configure a point-to-multi-point wireless bridge as shown in [Figure 5-7](#):

- Under the **Configuration** tab, select **Wireless Bridge**. Then, select **Bridging**. The Bridging screen displays.

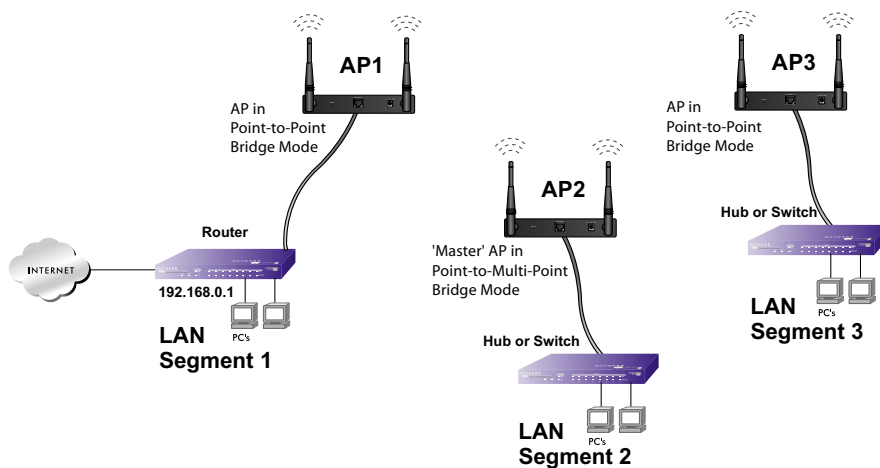

Figure 5-7 Wireless point-to-multipoint bridge setup

- Configure the Operating Mode of the WN604 Wireless Access Points.
 - WN604 (AP1) on LAN Segment 1 in Point-to-Point Bridge mode with the Remote MAC Address of AP2.
 - Because it is in the central location, configure WN604 (AP2) on LAN Segment 2 in Point-to-Multi-Point Bridge mode. The MAC addresses of the adjacent APs are required in AP2.
 - Configure the WN604 (AP3) on LAN 3 in Point-to-Point Bridge mode with the Remote MAC Address of AP2.
- Verify the following parameters for all access points:
 - Verify that the LAN network configuration the WN604 Wireless Access Points are configured to operate in the same LAN network address range as the LAN devices

- Only one access point is configured in Point-to-Multi-Point Bridge mode, and all the others are in Point-to-Point Bridge mode.
 - All access points must be on the same LAN. That is, all the APs LAN IP address must be in the same network.
 - If using DHCP, all WN604 Wireless Access Points should be set to “Obtain an IP address automatically (DHCP Client)” in the IP Address Source portion of the Basic IP Settings menu.
 - All WN604 Wireless Access Points use the same SSID, Channel, authentication mode, if any, and encryption in use.
 - All Point-to-Point Access Points must have the AP2 MAC address in its Remote AP MAC address field.
4. Verify connectivity across the LANs.
- A computer on any LAN segment should be able to connect to the Internet or share files and printers with any other PCs or servers connected to any of the three LAN segments.
 - Wireless stations will be able to connect to the WN604 Wireless Access Points in the illustration above. If you require wireless stations to access any LAN segment, you can add additional WN604 Wireless Access Points configured in Wireless Access Point mode to any LAN segment.
5. Click **Apply** to save your settings.



Note: You can extend this multi-point bridging by adding additional WN604s configured in Point-to-Point mode for each additional LAN segment. Furthermore, you can extend the range of the wireless network with NETGEAR wireless antenna accessories.

Chapter 6

Troubleshooting and Debugging

This chapter provides information about troubleshooting your NETGEAR Wireless N150 Access Point WN604. After each problem description, instructions are given to help you diagnose and solve the problem. For the common problems listed, go to the section indicated.

- Is the WN604 on?
Go to “[Installing the WN604 Wireless Access Point](#)” on page 2-3
- Have I connected the wireless access point correctly?
Go to “[Installing the WN604 Wireless Access Point](#)” on page 2-3.
- I cannot remember the wireless access point’s configuration password.
Go to “[Changing the Administrator Password](#)” on page 4-6.



Note: For up-to-date WN604 installation details and troubleshooting guidance visit <http://kbserver.netgear.com/products/WN604.asp>.

If you have trouble setting up your WN604, check the tips below.

No lights are lit on the wireless access point.

It takes a few seconds for the power indicator to light up. Wait a minute and check the power light status on the access point.

If the access point has no power.

- Make sure the power cord is connected to the access point.
- Make sure the power adapter is connected to a functioning power outlet. If it is in a power strip, make sure the power strip is turned on. If it is plugged directly into the wall, verify that it is not a switched outlet.
- Make sure you are using the correct NETGEAR power adapter supplied with your access point.

The Wireless LAN activity light does not light up.

The access point antennas are not working.

- If the Wireless LAN activity light stays off, disconnect the adapter from its power source and then plug it in again.
- Make sure the antennas are tightly connected to the WN604.
- Contact NETGEAR technical support if the Wireless LAN activity light remains off.

The LAN light is not lit.

There is a hardware connection problem. Check these items:

- Make sure the cable connectors are securely plugged in at the access point and the network device (hub, switch, or router). A switch, hub, or router must be installed between the access point and the Ethernet LAN or broadband modem.
- LAN light does not light up if it is a 10 Mbps link. In such cases, the Lan activity light will still blink if there is activity.
- Make sure the connected device is turned on.
- Be sure the correct cable is used. Use a standard Category 5 Ethernet patch cable. If the network device has Auto Uplink™ (MDI/MDIX) ports, you can use either a crossover cable or a normal patch cable.

I cannot access the Internet or the LAN with a wireless capable computer.

There is a configuration problem. Check these items:

- You may not have restarted the computer with the wireless adapter to have TCP/IP changes take effect. Restart the computer.
- The computer with the wireless adapter may not have the correct TCP/IP settings to communicate with the network. Restart the computer and check that TCP/IP is set up properly for that network. The usual setting for Windows the Network Properties is set to “Obtain an IP address automatically.”

- The access point's default values may not work with your network. Check the access point default configuration against the configuration of other devices in your network.

I cannot connect to the WN604 to configure it.

Check these items:

- The WN604 is properly installed, LAN connections are OK, and it is powered on. Check that the LAN port LED is green to verify that the Ethernet connection is OK.
- The default configuration of the WN604 is for a static IP address of 192.168.0.100 and a Mask of 255.255.255.0 with DHCP disabled. Make sure your network configuration settings are correct.
- If you are using the NetBIOS name of the WN604 to connect, ensure that your computer and the WN604 are on the same network segment or that there is a WINS server on your network.
- If your computer is set to "Obtain an IP Address automatically" (DHCP client), restart it.
- If your computer uses a Fixed (Static) IP address, ensure that it is using an IP Address in the range of the WN604. The WN604 default IP Address is 192.168.0.100 and the default Subnet Mask is 255.255.255.0. If you are not sure about these settings, follow the instructions for ["Installing the WN604 Wireless Access Point" on page 2-3.](#)

When I enter a URL or IP address I get a timeout error.

A number of things could be causing this. Try the following troubleshooting steps.

- Check whether other PCs work. If they do, ensure that your PCs TCP/IP settings are correct. If using a Fixed (Static) IP Address, check the Subnet Mask, Default Gateway, DNS, and IP Addresses.
- If the PCs are configured correctly, but still not working, ensure that the WN604 is connected and turned on. Connect to it and check its settings. If you cannot connect to it, check the LAN and power connections.
- If the WN604 is configured correctly, check your Internet connection (DSL/Cable modem etc.) to make sure that it is working correctly.
- Try again.

Using the Reset Button to Restore Factory Default Settings

The Reset button (see [“Rear Panel” on page 1-8](#)) has two functions:

- **Reboot.** When pressed and released quickly, the WN604 will reboot (restart).
- **Reset to Factory Defaults.** This button can also be used to clear ALL data and restore ALL settings to the factory default values.

To clear all data and restore the factory default values:

1. Power off the WN604 and power it back on.
2. Use something with a small point, such as a pen, to press the Reset button in and hold it in for at least 5 seconds.
3. Release the Reset button.

The factory default configuration has now been restored, and the WN604 is ready for use.

Appendix A

Default Settings and Technical Specifications

This appendix provides the factory default settings and technical specifications for the NETGEAR Wireless N150 Access Point WN604.

Factory Default Settings

You can use the reset button located on the front of your device to reset all settings to their factory defaults. This is called a hard reset.

- To perform a hard reset, push and hold the reset button for approximately 5 seconds (until the Wireless LED blinks rapidly). Your device will return to the factory configuration settings shown in [Table A-1](#) below.
- Pressing the reset button for a shorter period of time will simply cause your device to reboot.

Table A-1. Access Point Default Configuration Settings

Feature	Description
AP Login	
User Login URL	192.168.0.100
User Name (case sensitive)	'admin'
Login Password (case sensitive)	'password'
Ethernet Connection	
Static IP Address	
Ethernet MAC Address	See bottom label.
Port Speed	10/100
Local Network (LAN)	
Lan IP	
Subnet Mask	255.255.255.0
Gateway Address	
DHCP Client	Disabled

Table A-1. Access Point Default Configuration Settings

Feature		Description
	Time Zone	USA-Pacific
Wireless		
	Operating Mode	Access Point
	Access Point Name	netgearxxxxxx where xxxxxx are the last 6 digits of the wireless access point "Ethernet" MAC address.
	Wireless Communication	Enabled
	Wi-Fi Protected Setup (WPS)	Disabled
	11 b/bg/ng Wireless Network Name (SSID)	NETGEAR_11ng
	Broadcast Network Name SSID	Enabled
	Security	Disabled
	Transmission Speed	Best ^a
	Country/Region	Varies by region
	Scheduled Wireless ON/OFF	Disabled
	80211.b/bg/ng Radio Frequency Channel	Auto
	Output Power	Full
	Wireless Card Access List	All wireless stations allowed
	WMM Support	Enabled

a. Maximum Wireless signal rate derived from IEEE Standard 802.11 specifications. Actual throughput will vary. Network conditions and environmental factors, including volume of network traffic, building materials and construction, and network overhead, lower actual data throughput rate.

Technical Specifications

Table A-2. WN604 Technical Specifications

Parameter	NETGEAR Wireless N150 Access Point WN604
802.11g Data Rates	1, 2, 5.5, 11, 12, 18, 24, 36, 38, 54, & 108 Mbps (Auto-rate capable)
802.11ng Data Rates	Data Rates for Channel Width=20MHz and Guard Interval=short (400ms): Best, 7.2 Mbps, 14.4 Mbps, 21.7 Mbps, 28.9 Mbps, 43.3 Mbps, 57.8 Mbps, 65 Mbps, 72.2 Mbps
	Data Rates for Channel Width=20MHz and Guard Interval=long (800ms): Best, 6.5 Mbps, 13 Mbps, 19.5 Mbps, 26 Mbps, 39 Mbps, 52 Mbps, 58.5 Mbps, 65 Mbps
	Data Rates for Channel Width=40MHz and Guard Interval=short: Best, 15 Mbps, 30 Mbps, 45 Mbps, 60 Mbps, 90 Mbps, 120 Mbps, 135 Mbps, 150 Mbps
	Data Rates for Channel Width=40MHz and Guard Interval=long: Best, 13.5 Mbps, 27 Mbps, 40.5 Mbps, 54 Mbps, 81 Mbps, 108Mbps, 121.5 Mbps, 135 Mbps
802.11b/bg/ng Operating Frequencies	2.412 ~ 2.462 GHz (US) 2.457 ~ 2.462 GHz (Spain) 2.412 ~ 2.484 GHz (Japan) 2.457 ~ 2.472 GHz (France) 2.412 ~ 2.472 GHz (Europe ETSI)
802.11 b/bg/ng Encryption	64-bits, 128- and 152-bits WEP, AES, TKIP data encryption
Network Management	Web-based configuration and status monitoring
Maximum Clients	Limited by the amount of wireless network traffic generated by each node; maximum 64 supported.
Status LEDs	Power/Ethernet LAN/Wireless LAN/Wi-Fi /WPS function
Power Adapter	12V DC, 1 A
Electromagnetic Compliance	FCC Part 15 Class B and Class E, CE, and C-TICK
Environmental Specifications	Operating temperature: 0 to 40° C; Storage temperature: -20 to 70° C Operating humidity: 10-90% RH; Storage humidity: 5-95% RH

Appendix B

Related Documents

This appendix provides links to reference documents you can use to gain a more complete understanding of the technologies used in your NETGEAR product.

Document	Link
Internet Networking and TCP/IP Addressing	http://documentation.netgear.com/reference/enu/tcpip/index.htm
Wireless Communications	http://documentation.netgear.com/reference/enu/wireless/index.htm
Preparing a Computer for Network Access	http://documentation.netgear.com/reference/enu/wsdhcp/index.htm
Glossary	http://documentation.netgear.com/reference/enu/glossary/index.htm

Numerics

- 2.4 GHz/5 GHz concurrent *1-2*
- 20 MHz *2-16*
- 20/40 MHz *2-16*
- 40 MHz *2-16*
- 802.11a/b/g/n *1-3*
 - standards compliance *1-2*
- 802.11b/g/n *2-13*
 - default SSID *2-10*
- 802.11e *1-3, 2-17, 5-4*
- 802.11n
 - data encryption option, recommendation *2-3*

A

- access control
 - MAC address filtering *1-3*
 - MAC authentication *3-22*
 - trusted wireless stations *1-3*
- access control list
 - MAC authentication *3-22*
- access point mode
 - security options *3-3*
- access point name *2-5*
- access point, more than one *2-15*
- ACK *1-3*
- activity log *4-8*
- AES
 - 802.11n, recommended for *2-3*
 - with WPA2, with RADIUS *3-16*
 - with WPA2-PSK *3-20*
- aggregation length *5-4*
- aggregation, support for *1-3*
- AID see association ID

- A-MPDU (Aggregation of MAC Protocol Data Units) *5-4*
- antenna
 - 2.4 GHz *1-8*
 - 5 GHz *1-8*
 - accessories *5-11*
 - position *2-2, 2-10*
- AP's PIN *3-5*
- associated stations
 - present in AWSL, only *4-12*
- association ID
- authentication server settings
 - IP address *3-10, 3-11*
 - port number *3-10, 3-11*
 - shared secret *3-11*
- auto or long preamble, support for *1-3*
- Auto UplinkTM *1-4*
- autosensing ethernet, support for *1-3*
- autosensing, LAN interface *1-4*
- available wireless station list (AWSL) *4-12*
- available wireless stations list *3-23*
- AWSL table fields
 - channel *4-12*
 - MAC address *4-12*
 - mode *4-12*
 - rate *4-12*
 - SSID *4-12*
 - state *4-12*
 - status *4-12*
 - type *4-12*
 - wireless network name (SSID) *4-12*

B

- back off *1-3*
- beacon generation, support for *1-3*

beacon interval 5-4

bridge

network authentication 3-3

bridge mode wireless station

wireless point to point bridge 5-6

wireless point-to-multi-point bridge 5-7

BSSID 4-12

C

Category 5 Ethernet cable 1-5

change password 4-6

channel auto

testing connectivity 2-18

channel auto selection 2-18

channel interference 2-18

channel spacing 2-2

channel spacing, recommended 2-15

channel, auto

configuring channel/frequency 2-15

channel, default 2-15

configuration file 4-3

conventions, typographical 1-xi

country/region, configure 2-6

coverage 2-2

coverage area 1-1, 2-9

CSMA/CA 5-3

CSMA/CD (Carrier Sense Multiple Access with Collision Detection) 5-3

CTS (Clear to Send) 5-3

D

data encryption settings

128 bits WEP 3-4

152 bits WEP 3-4

64 bits WEP 3-4

AES 3-4

none 3-4

TKIP 3-4

TKIP + AES 3-4

data rates 802.11bgn 2-15

default access point name 2-6

default channel 2-15, 2-18

default gateway, configure 2-13

default IP address 2-4, 2-12

default password 2-4

default reset button 4-5

default SSID 2-10

default user name 2-4

default wireless access point name 2-10

DHCP

point-to-multi-point bridging 5-11

DHCP client

default setting 2-10

DHCP client, configure 2-12

DHCP client/server

support 1-2

DHCP server

on LAN 2-12

on LAN, assigns IP address 2-10

distributed coordinated function, support for 1-3

documentation 2-5

DTIM (Delivery Traffic Indication Message) interval 5-4

dual band concurrent, use 1-2

dynamic encryption key generation, support 1-2

dynamic IP address, configure 2-10

dynamic per frame rekeying 2-3

E

EDCA (Enhanced Distributed Channel Access) 5-5

Ethernet

RJ-45 port 1-8

ethernet cable, connect 2-10

External Registrar, WPS 3-5

F

factory default settings 4-3

reset button 1-8, 6-4

resetting 6-4

restore 4-4

- table A-1
- firmware
 - upgrade 4-2
- FLASH 4-1
- formats, document 1-xi
- fragmentation 5-4
- fragmentation threshold 5-4
- front panel 1-6
- full-duplex 1-4

H

- half-duplex 1-4
- hidden mode, support for 1-3
- hotspot
 - wireless client security separation 3-13
 - wireless client security separation 3-15, 3-17, 3-18, 3-19, 3-20, 3-21
- how to print, manual 1-xii

I

- interference, channel settings 2-15
- interference, least 2-15
- interference, reduce 2-2, 2-15
- interference, sources 2-2
- IP address
 - configure 2-7, 2-12
- IP settings, configure 2-12

K

- keys, use with WEP 3-4

L

- LAN IP address
 - default 6-3
- latency 2-2
- LED indicators, table of 1-6
- legacy rates 2-3
- line of sight 2-9

- location 2-2, 2-9
- log in 2-11
- logs 4-7, 4-8

M

- MAC address
 - access control list 3-22
 - bridge mode wireless station 5-6
 - wireless point-to-multi-point bridge 5-7
- MAC authentication
 - available wireless stations list 3-23
 - MAC address database, local 3-23
 - MAC address database, RADIUS 3-23
 - trusted wireless stations 3-23
 - turn access control on 3-23
- max users 1-1
- maximum packet size 5-4
- multiple access points
 - placement of 2-2
- multiple input, multiple output (MIMO), support for 1-3
- multi-point bridging
 - extend 5-11
 - extend range 5-11

N

- NetBIOS name 2-6
- Netgear products, compatible 1-4
- network authentication, types of
 - open system 3-3
 - shared key 3-3
 - WPA and WPA2 with RADIUS 3-3
 - WPA with RADIUS 3-3
 - WPA2 with RADIUS 3-3
 - WPA2-PSK 3-3
 - WPA-PSK 3-3
 - WPA-PSK and WPA2-PSK 3-3
- network key
 - with WPA-PSK and WPA2-PSK 3-21
 - WPA-PSK 3-19
- network statistics 4-10
 - fields 4-11
- NTP client, configure 2-8

NTP server, configure 2-8

O

operating modes, supported
point-to-multi-point bridge. 1-2
point-to-point bridge 1-2
wireless access point 1-2

P

package contents 1-5
packet fragmentation, support for 1-3
packet size 5-3
passphrase, use with WEP 3-4, 3-13
password
change 4-6
performance degradation
causes of 2-2
placement 2-2
point-to-multi-point bridge 5-7
configure 5-10
point-to-point bridge 5-6
configure 5-9
point-to-point bridge mode
wireless point-to-multi-point bridge 5-7
power adapter 1-8
power consumption 2-2
preamble type 5-4
preshared key passphrase
WPA-PSK 3-19
primary DNS server, configure 2-13
product registration 1-ii
profile name
bridge mode wireless station 5-6
wireless point-to-multi-point bridge 5-7

Q

QoS queues 5-6
QoS settings 2-17
QoS settings, advanced

AP EDCA parameters 5-5
station EDCA parameters 5-5

R

RADIUS and certificate authentication, support 1-2
RADIUS server, configure 3-9
accounting server 3-11
authentication server 3-10
RADIUS server, configure first 3-2, 3-11
range 1-1
guidelines 2-2
rear panel 1-8
reboot 4-5
reset button, using 6-4
rebooting
losing previous state 4-13
reception 2-2
reduced inter frame spacing, support for 1-3
registering 1-ii
Registrar, WPS 3-5
request to send threshold 5-3
reset button 4-5
reset to factory defaults 4-5
retransmission 1-3
revision history 1-xiii
RIFS
wireless settings 5-4
roaming
multiple wireless access points 4-12
roaming on same subnet, support for 1-3
RTS 5-3
RTS/CTS handshake, support for 1-3

S

Scheduled Wireless 5-1
security profile definition
authentication settings 3-3
broadcast wireless network name (SSID) 3-3
data encryption 3-4
wireless client security separation 3-4

- wireless network name (SSID) 3-2
- security profiles
 - about 3-2
- security profiles, setting up 3-11
- security profile
 - wireless client security separation 3-12
- setup form 3-8
- software upgrade 4-2
- SSID 2-15
 - hidden mode 1-3
- SSID broadcast, disable 3-3
- SSID match
 - verify connectivity 2-10
- SSID, wireless network name 3-2
- standards, supported 1-2
- static IP address 6-3
 - default 2-4
- statistics 4-10
- subnet mask
 - default 6-3
- support 1-ii
- support documentation 2-5
- syslog server
 - setup 4-7
- system information 4-8
 - fields 4-9
- system requirements 1-5

T

- technical specifications A-3
- throughput performance 2-2
- timezone, configure 2-6, 2-8
- timezone, default 2-8
- TKIP
 - data rates, provided by 2-3
 - with WPA, with RADIUS 3-15
 - with WPA-PSK 3-19
- TKIP+AES
 - with WPA and WPA2, with RADIUS 3-18
 - with WPA-PSK + WPA2-PSK 3-21

- transmit power 2-16
- troubleshooting 6-1
 - access point, connecting to 6-3
 - configuring, 6-3
 - LAN activity 6-2
 - power connection 6-1
 - timeout error 6-3
 - wireless Internet connection 6-2
 - wireless LAN activity 1 6-2
- trusted wireless stations list
 - MAC authentication 3-23

U

- unauthorized access, secure from 2-1
- upgradeable firmware, support for 1-3

V

- Voice-over-IP (VoIP) 5-5

W

- WEP
 - data rates, provided by 2-3
- WEP, configure
 - data encryption keys 3-13
 - data encryption strength 3-13
 - network authentication type 3-12
 - wireless client security separation 3-13
- Wi-Fi Multimedia (WMM) 5-4
- Wi-Fi Protected Access (WPA) 2-3
- Wi-Fi Protected Setup (WPS) 3-5
- wired equivalent privacy (WEP) 2-3
- wireless access point
 - software 4-1
- wireless access point name 2-10
- wireless adapter
 - verifying connectivity 2-10
- wireless adapter, settings 2-19
- wireless adapters
 - WPA support, restriction 3-14
 - WPA2 support, restriction 3-16

- wireless bridging and repeating 5-6
- wireless channel
 - changing 2-15, 2-18
- wireless client security separation
 - hotspot setting 3-13
- wireless computer, configuring from 3-14
- wireless connection
 - losing 3-22
- wireless connection, losing 2-19
- wireless connectivity, testing 2-18
- Wireless Multimedia (WMM) 2-17
- Wireless Multimedia (WMM), support for 1-3
- Wireless Multimedia Extension (WME) 5-4
- wireless network name (SSID) 3-12
- wireless point-to-multi-point bridge 5-7
- wireless point-to-point bridge 5-6
- wireless security options
 - restrict access based on MAC address. 2-3
 - turn off broadcast of wireless network name (SSID) 2-3
 - WEP, use 2-3
 - WPA or WPA-PSK, use 2-3
- wireless settings 802.11b/bg/ng, advanced
 - aggregation length 5-4
 - A-MPDU 5-4
 - beacon interval 5-4
 - DTIM interval 5-4
 - fragmentation length 5-4
 - preamble type 5-4
 - RIFS transmission 5-4
 - RTS threshold 5-3
- wireless settings 802.11bgn
 - broadcast wireless network name (SSID) 2-15
 - channel width 2-16
 - channel/frequency 2-15
 - guard interval 2-16
 - MCS index/data rate 2-15
 - output power 2-16
 - turn radio on 2-15
 - wireless mode 2-14
 - wireless network name (SSID) 2-15
- wireless settings, basic 2-9
- wireless sniffer 2-3
- WPA and WPA2 with RADIUS
 - restriction with WPA and WPA2 3-17
- WPA and WPA2 with RADIUS, configure 3-17
 - data encryption 3-18
 - network authentication type 3-18
 - wireless client security separation 3-18
- WPA preshared key passphrase, use with WPA-PSK 3-4
- WPA with RADIUS, configure 3-14
 - data encryption default 3-15
 - network authentication type 3-15
 - wireless client security separation 3-15
 - WPA with RADIUS, restrictions 3-14
- WPA/WPA2
 - use restrictions 3-3
- WPA/WPA2, support for 1-2
- WPA2 with RADIUS, configure 3-16
 - data encryption default 3-16
 - network authentication type 3-16
 - wireless client security separation 3-17
- WPA2-PSK, configure
 - data encryption 3-20
 - network authentication type 3-20
 - preshared key passphrase 3-20
 - restrictions using WPA2 3-20
 - wireless client security separation 3-20
- WPA-PSK and WPA2-PSK preshared key authentication, support 1-2
- WPA-PSK and WPA2-PSK, configure
 - data encryption 3-21
 - network authentication setting 3-21
 - restrictions using WPA/WPA2 3-20
 - wireless client security separation 3-21
 - WPA passphrase (network key) 3-21
- WPA-PSK, configure
 - data encryption 3-19
 - network authentication type 3-19
 - preshared key passphrase 3-19
 - restrictions for WPA 3-19
 - wireless client security separation 3-19
- WPS 3-5
- WPS Client, Add 3-6
- WPS PIN 3-5