

# NETGEAR®

---

## Mobile LTE Broadband 11n Wireless Router MBR1516 User Manual



350 East Plumeria Drive  
San Jose, CA 95134  
USA

August 2012  
202-11098-01  
v1.0

## Mobile LTE Broadband 11n Wireless Router MBR1516

© 2012 NETGEAR, Inc. All rights reserved.

No part of this publication may be reproduced, transmitted, transcribed, stored in a retrieval system, or translated into any language in any form or by any means without the written permission of NETGEAR, Inc.

### Technical Support

Thank you for choosing NETGEAR. To register your product, get the latest product updates, or get support online, visit us at <http://support.netgear.com>.

Phone (US & Canada only): 1-888-NETGEAR

Phone (Other Countries): See Support information card.

### Trademarks

NETGEAR, the NETGEAR logo, and Connect with Innovation are trademarks and/or registered trademarks of NETGEAR, Inc. and/or its subsidiaries in the United States and/or other countries. Information is subject to change without notice. Other brand and product names are registered trademarks or trademarks of their respective holders. © 2012 NETGEAR, Inc. All rights reserved.

### Statement of Conditions

To improve internal design, operational function, and/or reliability, NETGEAR reserves the right to make changes to the products described in this document without notice. NETGEAR does not assume any liability that may occur due to the use, or application of, the product(s) or circuit layout(s) described herein.

# Contents

## Chapter 1 Hardware Setup

Unpack Your Router . . . . .	7
Hardware Features . . . . .	8
Front Panel . . . . .	8
Back Panel . . . . .	10
Label . . . . .	11
Restore Factory Settings . . . . .	11
Insert the SIM Card . . . . .	12
Install Optional External Antennas . . . . .	12
Position Your Router . . . . .	14

## Chapter 2 Getting Started with NETGEAR genie

Router Setup Preparation . . . . .	16
Use Standard TCP/IP Properties for DHCP . . . . .	16
Gather ISP Information . . . . .	16
Wireless Devices and Security Settings . . . . .	16
Types of Logins and Access . . . . .	16
NETGEAR genie Setup . . . . .	17
Use NETGEAR genie after Installation . . . . .	18
Upgrade Router Firmware . . . . .	18
Router Dashboard (Basic Home Screen) . . . . .	19
Add Wireless Devices or Computers to Your Network . . . . .	20
Manual Method . . . . .	20
Wi-Fi Protected Setup (WPS) Method . . . . .	20

## Chapter 3 NETGEAR genie Basic Settings

Internet Setup . . . . .	22
Internet Setup Screen Fields . . . . .	22
Wireless Settings . . . . .	24
Wireless Settings Screen Fields . . . . .	25
Change WPA Security Option and Passphrase . . . . .	26
Attached Devices . . . . .	26
Parental Controls . . . . .	27
SMS Message . . . . .	30
View SMS Messages . . . . .	30
Send SMS Messages . . . . .	31

## Chapter 4 NETGEAR genie Advanced Home

Setup Wizard	33
WPS Wizard	34
Setup Menu	35
Broadband Settings	36
Mobile Broadband Settings	36
WAN Setup	38
Default DMZ Server	39
Change the MTU Size	39
LAN Setup	41
LAN Setup Screen Settings	42
Use the Router as a DHCP Server	42
Address Reservation	43
Quality of Service (QoS) Setup	44

## Chapter 5 Security

Keyword Blocking of HTTP Traffic	50
Block Services (Port Filtering)	51
Schedule Blocking	53
Security Event Email Notifications	54

## Chapter 6 Administration

Router Status	56
Logs	59
Attached Devices	60
Backup Settings	60
Back Up Settings	60
Restore Configuration Settings	60
Erase	61
Set Password	61
Password Recovery	62
Diagnostics	62
Router Upgrade	63
Module Upgrade	64

## Chapter 7 Advanced Settings

SIM Settings	67
SMS Messages	67
Wireless Settings	68
Wireless Repeating	70
Wireless Repeating Function	71
Set Up the Base Station	72
Set Up a Repeater Unit	72
Port Forwarding and Port Triggering	73
Remote Computer Access Basics	73

## Mobile LTE Broadband 11n Wireless Router MBR1516

Port Triggering to Open Incoming Ports . . . . .	75
Port Forwarding to Permit External Host Communications . . . . .	76
How Port Forwarding Differs from Port Triggering . . . . .	77
Set Up Port Forwarding to Local Servers . . . . .	77
Set Up Port Triggering . . . . .	79
Dynamic DNS . . . . .	81
Static Routes . . . . .	82
Remote Management . . . . .	85
Universal Plug and Play . . . . .	86
Traffic Meter . . . . .	87

### Chapter 8 Troubleshooting

Basic Functioning . . . . .	90
Troubleshoot Access to the Router Main Menu . . . . .	92
Troubleshoot the ISP Connection . . . . .	93
Connect to the Internet . . . . .	93
Troubleshoot Internet Browsing . . . . .	95
Troubleshoot a TCP/IP Network Using the Ping Utility . . . . .	95
Test the LAN Path to Your Router . . . . .	95
Test the Path from Your Computer to a Remote Device . . . . .	96
Problems with Date and Time . . . . .	97
Restore the Default Configuration and Password . . . . .	97

### Appendix A Supplemental Information

Factory Default Settings . . . . .	99
Technical Specifications . . . . .	101

### Appendix B Notification of Compliance

### Index

# Hardware Setup

---

# 1

## Getting to know your router

The Mobile LTE Broadband 11n Wireless Router MBR1516 provides you with an easy and secure way to set up a wireless home network with fast access to the Internet over a high-speed 4G wireless (LTE/HSPA+). It lets you block unsafe Internet content and applications, and protects the devices (computers, gaming consoles, and so on) that you connect to your home network.

If you have not already set up your new router using the installation guide that comes in the box, this chapter walks you through the hardware setup. *Chapter 3, NETGEAR genie Basic Settings*, explains how to set up your Internet connection.

This chapter contains the following sections:

- *Unpack Your Router*
- *Hardware Features*
- *Insert the SIM Card*
- *Install Optional External Antennas*
- *Position Your Router*

For more information about the topics covered in this manual, visit the Support website at <http://support.netgear.com>.

## Unpack Your Router

Open the box and remove the router, cables, and installation guide.

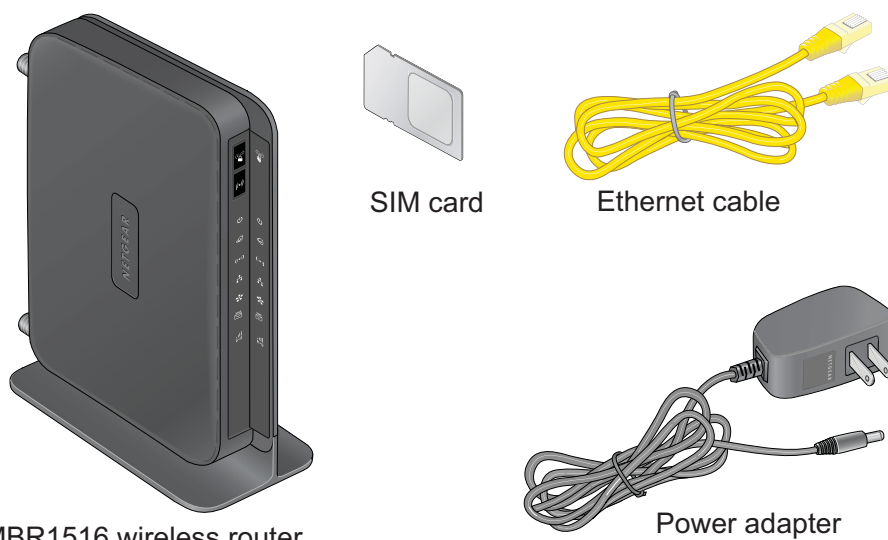

**Figure 1. Check the package contents**

Your box should contain the following items:

- Mobile LTE Broadband 11n Wireless Router MBR1516
- AC power adapter (plug varies by region)
- Category 5 (Cat 5) Ethernet cable
- Installation guide with cabling and router setup instructions

If any parts are incorrect, missing, or damaged, contact your NETGEAR dealer. Keep the carton and original packing materials, in case you need to return the product for repair.

## Hardware Features

Before you cable your router, take a moment to become familiar with the label and the front and back panels. Pay particular attention to the LEDs on the front panel.

### Front Panel

The router front panel contains control buttons and status LEDs. Use the LEDs to verify status and connections.

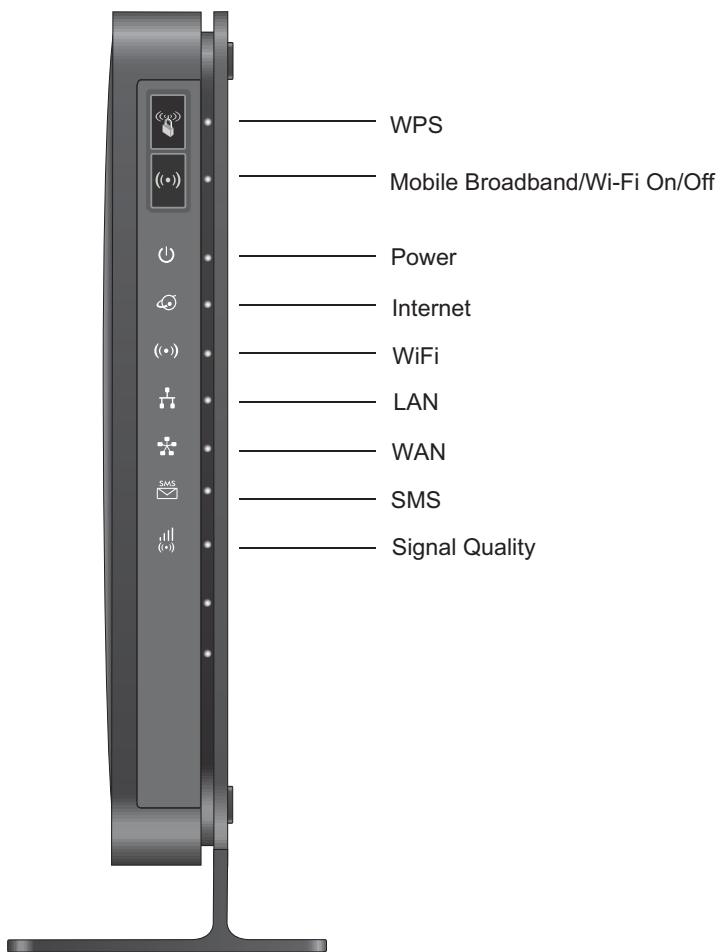

Figure 2. Router, front view



## Mobile LTE Broadband 11n Wireless Router MBR1516

*Table 1* describes each LED and button located on the front panel of the router.

**Table 1. LED Descriptions**









LED	Activity	Description
WPS 		Press the WPS button to open a 2-minute window for the router to connect with other WPS-enabled devices. For more information about this function, see <a href="#">Use Push 'N' Connect (WPS) to Configure Your Wireless Network</a> on page 30.
WiFi 		This button can be used to control the WiFi radio or both the WiFi radio and mobile broadband radio. Use the router interface to select the options. The default is set for WiFi radio only.
Power 	Solid green	The router is turned on and operating normally.
	Solid amber	POST (power-on self-test) in progress.
	Off	Power is not supplied to the router.
Internet Port 	Solid green	There is an Internet session.
	Solid amber	Traffic meter limit has been reached, traffic is blocked.
	Blinking green	Data is being transmitted over the Internet connection.
	Blinking amber	Traffic meter limit has been reached, but traffic not blocked.
	Blinking green and amber	Failover from WAN to Mobile Broadband.
	Off	No Internet connection detected.
Wi-Fi 	Solid blue	The Wi-Fi local port is initialized.
	Blinking blue	Data is being transmitted or received over the Wi-Fi link.
	Off	The wireless access point is turned off.
LAN Ports 	Solid green	The local Ethernet ports have detected wired links with computers.
	Blinking	Data is being transmitted or received.
	Off	No link is detected on these ports.
WAN Port 	Solid green	The Ethernet WAN port has detected an active link.
	Blinking	Data is being transmitted or received.
	Off	No link is detected on these ports.
SMS 	Solid green	SMS messages are waiting.
	Off	There are no unread SMS messages.

Table 1. LED Descriptions

LED	Activity	Description
	Solid blue	Excellent coverage detected.
	Solid green	Good coverage detected.
	Solid amber	Marginal coverage detected.
	Off	No coverage detected.

## Back Panel

The back panel of the router contains port connections.

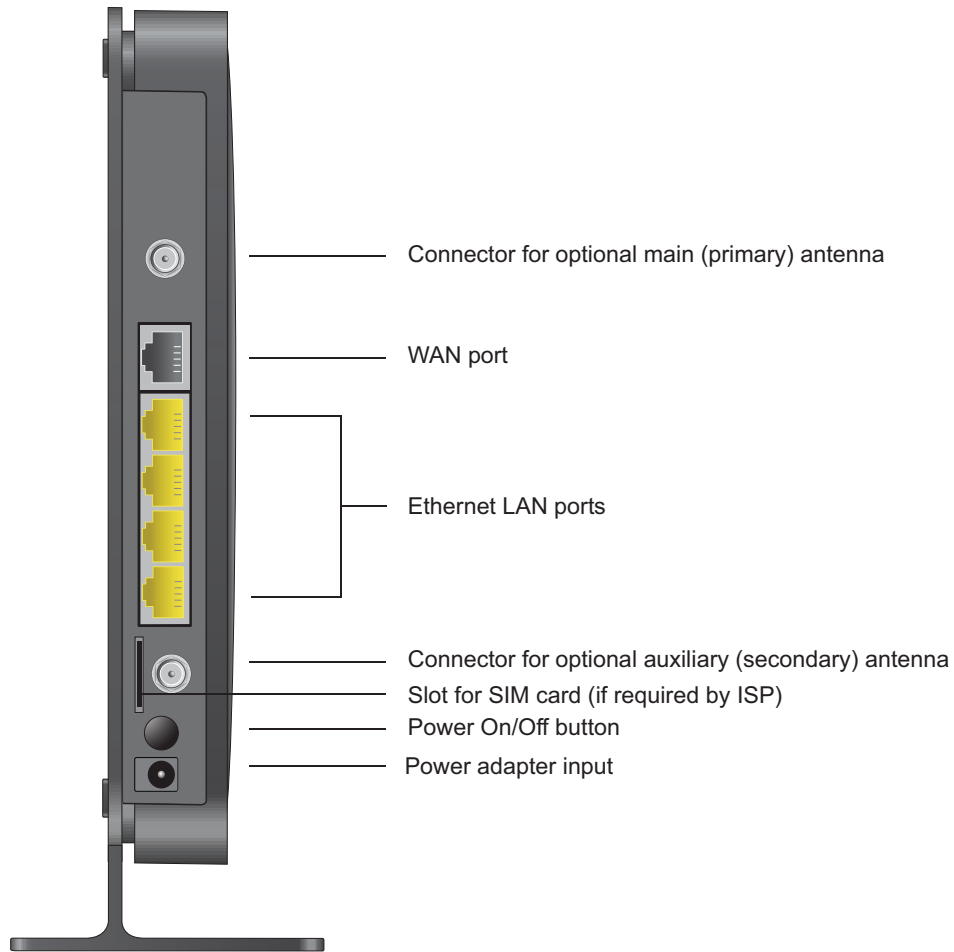

Figure 3. Router, rear view

## Label

The label on the side of the router shows the router's MAC address, serial number, security PIN, IMEI or ESN number, and factory default login information. It also contains the SSID and passphrase that is unique to each router.

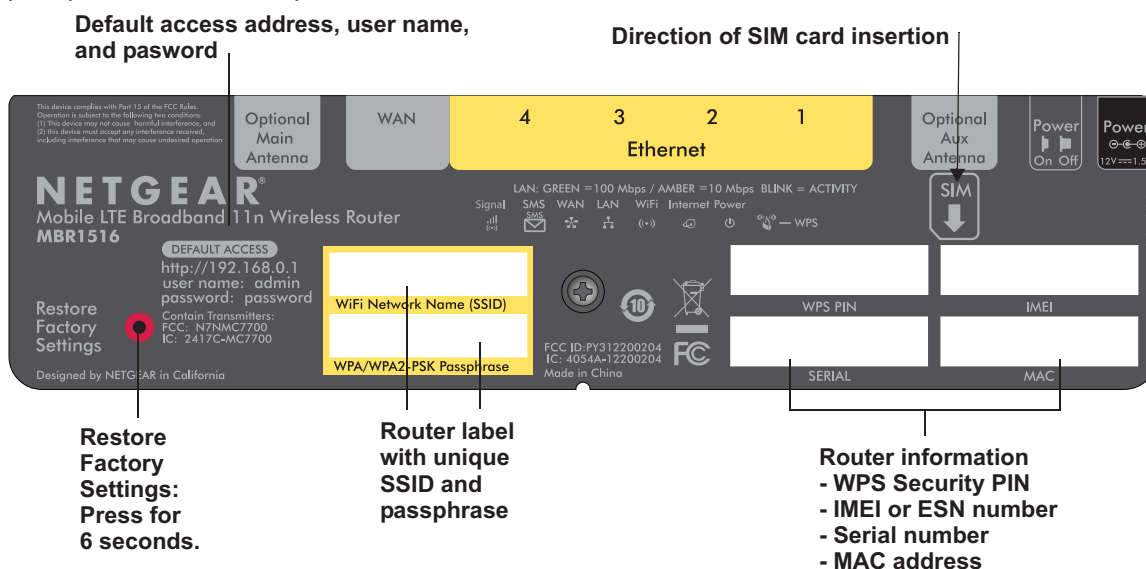

Figure 4. The label shows unique information about your router

## Restore Factory Settings



Locate the small hole outlined in red on the side of the router. Insert a paperclip into the hole and push for 6 seconds. Depressing the reset button causes the LED to blink briefly. After the button is held down for more than 6 seconds, the LED will flash AMBER, and then turn green as the router resets to the factory defaults. See [Factory Default Settings](#) on page 99 for information about restoring factory settings.

## Insert the SIM Card

If your ISP has provided you with a SIM card, inserted it into the SIM card slot on the back of the router. Otherwise, you cannot connect to the Internet.

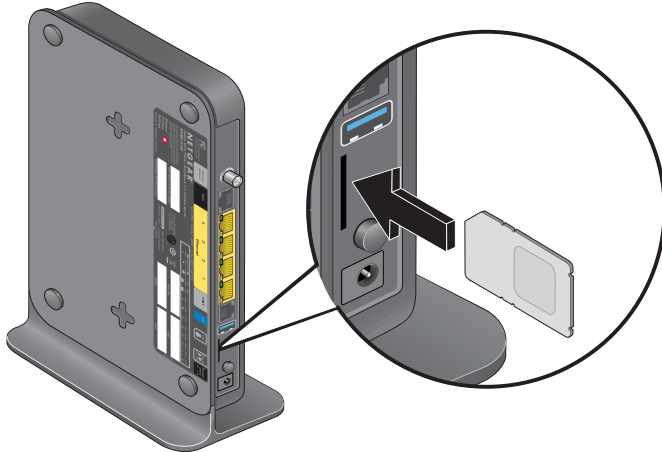

## Install Optional External Antennas

For improved performance, connect an external antenna to the main (primary) antenna port. For best 4G LTE performance, connect two external antennas to provide diversity.

➤ **To install the optional external antennas:**

1. To improve signal strength, purchase optional external antennas and install them on the back of the router.

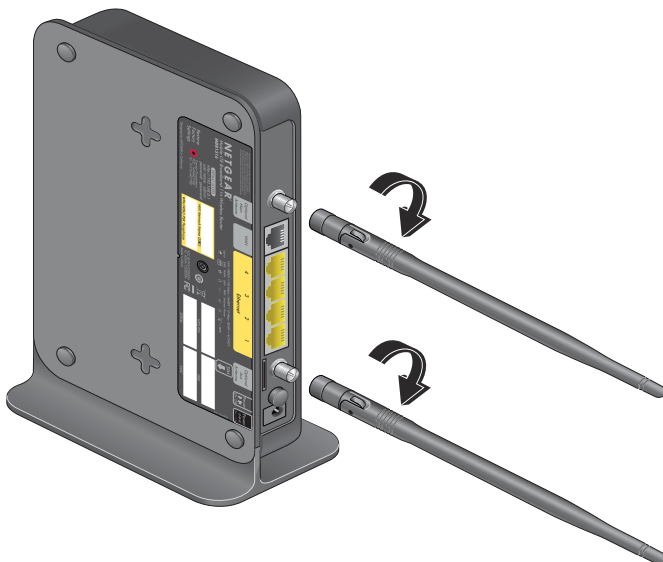

## Mobile LTE Broadband 11n Wireless Router MBR1516

2. Position the antennas so that they are at right angles to each other.



3. After you log in to the router (see [NETGEAR genie Setup](#) on page 17 for more information), clear the **Use Internal Antennas** check box on the Mobile Broadband Setting screen and click **Apply**. See [Mobile Broadband Settings](#) on page 36 for more information about this screen.

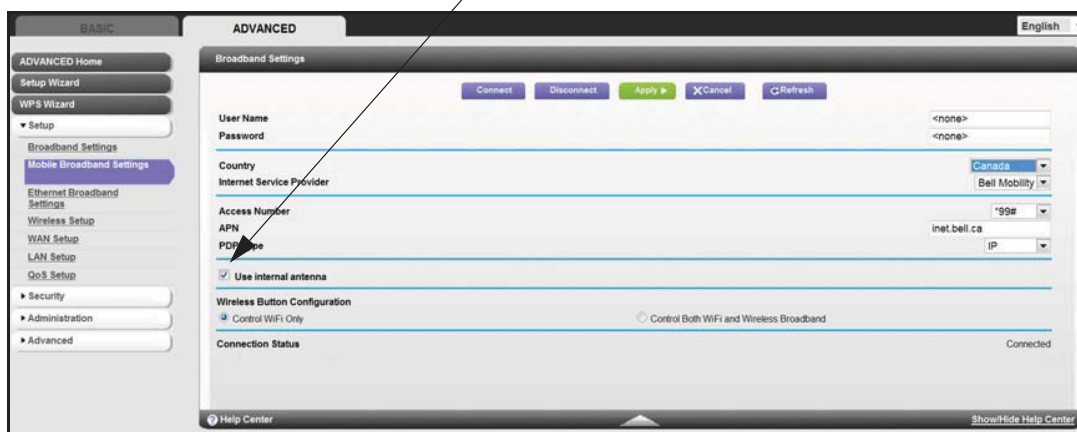

## Position Your Router

The router lets you access your network from virtually anywhere within the operating range of your wireless network. However, the operating distance or range of your wireless connection can vary significantly depending on the physical placement of your router. For example, the thickness and number of walls the wireless signal passes through can limit the range. For best results, place your router:

- Near the center of the area where your computers and other devices operate, and preferably within line of sight to your wireless devices.
- So it is accessible to an AC power outlet and near Ethernet cables for wired computers.
- In an elevated location such as a high shelf, keeping the number of walls and ceilings between the router and your other devices to a minimum.
- Away from electrical devices that are potential sources of interference, such as ceiling fans, home security systems, microwaves, computers, or the base of a cordless phone or 2.4 GHz cordless phone.
- Away from any large metal surfaces, such as a solid metal door or aluminum studs. Large expanses of other materials such as glass, insulated walls, fish tanks, mirrors, brick, and concrete can also affect your wireless signal.

When you use multiple access points, it is better if adjacent access points use different radio frequency channels to reduce interference. The recommended channel spacing between adjacent access points is 5 channels (for example, use Channels 1 and 6, or 6 and 11).

# Getting Started with NETGEAR genie

---

# 2

## Connecting to the router

This chapter explains how to use NETGEAR genie to set up your router after you complete cabling as described in the installation guide and in the previous chapter in this book.

This chapter contains the following sections:

- *Router Setup Preparation*
- *Types of Logins and Access*
- *NETGEAR genie Setup*
- *Use NETGEAR genie after Installation*
- *Upgrade Router Firmware*
- *Router Dashboard (Basic Home Screen)*
- *Add Wireless Devices or Computers to Your Network*

## Router Setup Preparation

You can set up your router with the NETGEAR genie automatically, or you can use the NETGEAR genie menus and screens to set up your router manually. However, before you start the setup process, you need to have your ISP information on hand and make sure the laptops, computers, and other devices in the network have the settings described here.

### Use Standard TCP/IP Properties for DHCP

If you set up your computer to use a static IP address, you need to change the settings so that it uses Dynamic Host Configuration Protocol (DHCP).

### Gather ISP Information

If you have 4G wireless (LTE/HSPA+) broadband service, you might need the following information to set up your router and to check that your Internet configuration is correct. Your Internet service provider (ISP) should have provided you with all of the information needed to connect to the Internet. If you cannot locate this information, ask your ISP to provide it. When your Internet connection is working, you no longer need to launch the ISP's login program on your computer to access the Internet. When you start an Internet application, your router automatically logs you in.

- The ISP configuration information for your 4G wireless (LTE/HSPA+) account
- 4G wireless (LTE/HSPA+) login name and password
- Fixed or static IP address settings (special deployment by ISP; this is rare)

### Wireless Devices and Security Settings

Make sure that the wireless device or computer that you are using supports WPA or WPA2 wireless security, which is the wireless security supported by the router.

## Types of Logins and Access

There are separate types of logins that have different purposes. It is important that you understand the difference so that you know which login to use when.

- **Router login** logs you in to the router interface from NETGEAR genie. See [Use NETGEAR genie after Installation](#) on page 18 for details about this login.
- **ISP login** logs you in to your Internet service. Your service provider has provided you with this login information in a letter or some other way. If you cannot find this login information, contact your service provider.
- **Wireless network key or password.** Your router is preset with a unique wireless network name (SSID) and password for wireless access. This information is on the label located on the bottom of your router.



## NETGEAR genie Setup

NETGEAR genie runs on any device with a web browser. It is the easiest way to set up the router because it automates many of the steps and verifies that those steps have been successfully completed. It takes about 15 minutes to complete.

➤ **To use NETGEAR genie to set up your router:**

1. Turn the router on by pressing the **On/Off** button, if not done yet.
2. Make sure that your device is connected with an Ethernet cable (wired) or wirelessly (with the preset security settings listed on the bottom label) to your router.
3. Launch your Internet browser.
  - If this is the first time you are setting up the Internet connection for your router, the browser automatically goes to <http://www.routerlogin.net>, and the NETGEAR genie screen displays.
  - If you already used the NETGEAR genie, type **<http://www.routerlogin.net>** in the address field for your browser to display the NETGEAR genie screen. See [Use NETGEAR genie after Installation](#) on page 18.
4. Follow the onscreen instructions to complete NETGEAR genie setup. NETGEAR genie guides you through connecting the router to the Internet.

**If the browser cannot display the web page:**

- Make sure that the computer is connected to one of the four LAN Ethernet ports, or wirelessly to the router.
- Make sure that the router is fully up and running. Its wireless LED should turn on.
- Close and re-open the browser to make sure the browser does not cache the previous page.
- Browse to **<http://routerlogin.net>**.
- If the computer is set to a static or fixed IP address (this is uncommon), change it to obtain an IP address automatically from the router.

**If the router does not connect to the Internet:**

1. Review your settings to be sure that you have selected the correct options and typed everything correctly.
2. Contact your ISP to verify that you have the correct configuration information.
3. Read [Chapter 8, Troubleshooting](#). If problems persist, register your NETGEAR product and contact NETGEAR technical support.

## Use NETGEAR genie after Installation

When you first set up your router, NETGEAR genie automatically starts when you launch an Internet browser on a computer that is connected to the router. You can use NETGEAR genie again if you want to view or change settings for the router.

1. Launch your browser from a computer or wireless device that is connected to the router.
2. Type **http://www.routerlogin.net** or **http://www.routerlogin.com**.

The login window displays:



The screenshot shows a login dialog box with a light beige background. It has two input fields: 'User name:' with a dropdown menu showing 'admin' and a small blue arrow icon, and 'Password:' with a text box containing '\*\*\*\*\*'. Below the password field is a checkbox labeled 'Remember my password' which is currently unchecked. At the bottom of the dialog are two buttons: 'OK' and 'Cancel'.

3. Enter **admin** for the router user name and **password** for the router password, both in lowercase letters.

**Note:** The router user name and password are different from the user name and password for logging in to your Internet connection. See [Types of Logins and Access](#) on page 16 for more information.

## Upgrade Router Firmware

When you set up your router and are connected to the Internet, the router automatically checks for you to see if newer firmware is available. If it is, a message is displayed on the top of the screen. See [Router Upgrade](#) on page 63 for more information about upgrading firmware.

Click the message when it shows up, and click **Yes** to upgrade the router with the latest firmware. After the upgrade, the router restarts.



### CAUTION:

Do not try to go online, turn off the router, shut down the computer, or do anything else to the router until the router finishes restarting and the Power LED has stopped blinking for several seconds.

## Router Dashboard (Basic Home Screen)

The router Basic Home screen has a dashboard that lets you see the status of your Internet connection and network at a glance. You can click any of the six sections of the dashboard to view more detailed information. The left column has the menus, and at the top there is an Advanced tab that is used to access additional menus and screens.

**Menus (Click the Advanced tab to view more)**

**Language**

**Dashboard (Click to view details)**

**Help**

**Figure 5. Router Basic Home screen with dashboard, language, and online help**

- **Home.** This dashboard screen displays when you log in to the router.
- **Internet.** Set, update, and check the ISP settings of your router.
- **Wireless.** View or change the wireless settings for your router.
- **Attached Devices.** View the devices connected to your network.
- **Parental Controls.** Download and set up parental controls to prevent objectionable content from reaching your computers.
- **SMS Message.** Send and receive SMS messages.
- **Advanced tab.** Set the router up for unique situations such as when remote access by IP or by domain name from the Internet is needed. See [Chapter 7, Advanced Settings](#). Using this tab requires a solid understanding of networking concepts.
- **Help & Support.** Go to the NETGEAR support site to get information, help, and product documentation. These links work once you have an Internet connection.

## Add Wireless Devices or Computers to Your Network

Choose either the manual or the WPS method to add wireless devices and other equipment to your wireless network.

### Manual Method

➤ **To connect manually:**

1. Open the software that manages your wireless connections on the wireless device (laptop computer, gaming device, iPhone) that you want to connect to your router. This software scans for all wireless networks in your area.
2. Look for your network and select it. If you did not change the name of your network during the setup process, look for the default Wi-Fi network name (SSID) and select it. The default SSID is located on the product label on the bottom of the router.
3. Enter the router password and click **Connect**. The default router passphrase is located on the product label on the bottom of the router.
4. Repeat steps 1–3 to add other wireless devices.

### Wi-Fi Protected Setup (WPS) Method

Wi-Fi Protected Setup (WPS) is a standard for easily adding computers and other devices to a home network while maintaining security. To use WPS, make sure that all wireless devices to be connected to the network are Wi-Fi certified and support WPS. During the connection process, the client gets the security settings from the router so that every device in the network has the same security settings.

➤ **To use WPS to join the wireless network:**

If your wireless device supports WPS (Push 'N' Connect), follow these steps:

1. Press the **WPS** button on the router front panel.
2. Within 2 minutes, press the **WPS** button on your wireless device, or follow the WPS instructions that came with the device. The device is now connected to your router.
3. Repeat steps 1–2 to add other WPS wireless devices.

# NETGEAR genie Basic Settings

# 3

## Your Internet connection and network

This chapter explains the features available from the NETGEAR genie Basic Home screen, shown in the following figure:

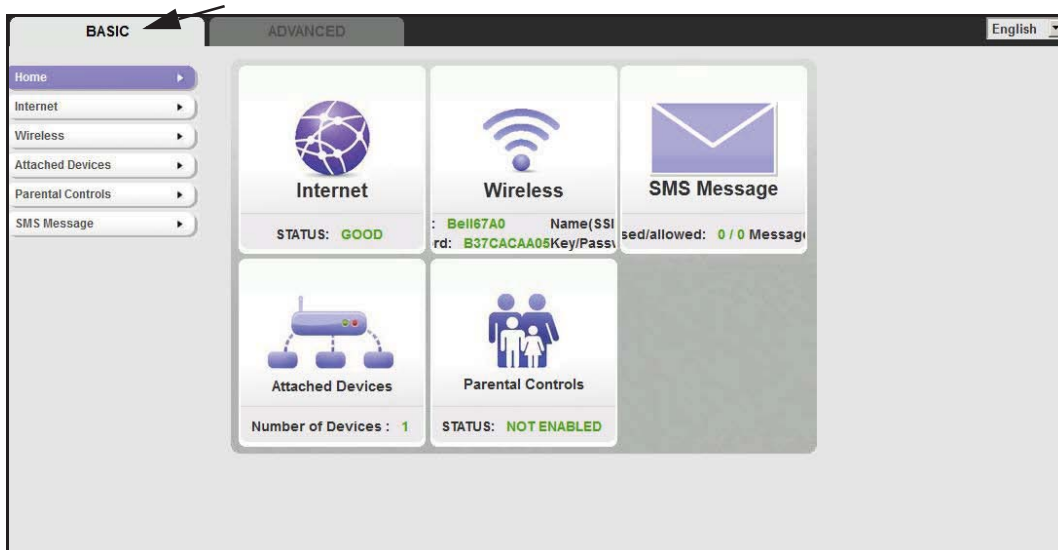

This chapter contains the following sections:

- *Internet Setup*
- *Wireless Settings*
- *Attached Devices*
- *Parental Controls*
- *SMS Message*

## Internet Setup

The Internet Setup screen is where you view or change ISP information.

1. From the Home screen, select **Internet**. The following screen displays:

The fields that display in the Internet Setup screen depend on whether or not your Internet connection requires a login.

- **Yes.** Select the encapsulation method and enter the login name. If you want to change the login time-out, enter a new value in minutes.
  - **No.** Enter the account and domain names, only if needed.
2. Enter the settings for the IP address and DNS server. The default settings usually work fine. If you have problems with your connection, check the ISP settings.
  3. Click **Apply** to save your settings.
  4. Click **Test** to test your Internet connection. If the NETGEAR website does not display within 1 minute, see [Chapter 8, Troubleshooting](#).

## Internet Setup Screen Fields

The following descriptions explain all of the possible fields in the Internet Setup screen. Note that which fields display in this screen depends on whether or not an ISP login is required.

**Does Your ISP Require a Login?** Answer either yes or no.

These fields display when no login is required:

- **Account Name (If required).** Enter the account name provided by your ISP. This might also be called the host name.
- **Domain Name (If required).** Enter the domain name provided by your ISP.

These fields display when your ISP requires a login:

- **Internet Service Provider Encapsulation.** ISP types. The choices are PPPoE, PPTP, or L2TP.
- **Login.** The login name provided by your ISP. This is often an email address.
- **Password.** The password that you use to log in to your ISP.
- **Idle Timeout (In minutes).** If you want to change the login timeout, enter a new value in minutes. This determines how long the router keeps the Internet connection active after there is no Internet activity from the LAN. Entering a value of 0 (zero) means never log out.

#### **Internet IP Address.**

- **Get Dynamically from ISP.** Your ISP uses DHCP to assign your IP address. Your ISP automatically assigns these addresses.
- **Use Static IP Address.** Enter the IP address, IP subnet mask, and the gateway IP address that your ISP assigned. The gateway is the ISP's router to which your router will connect.

**Domain Name Server (DNS) Address.** The DNS server is used to look up site addresses based on their names.

- **Get Automatically from ISP.** Your ISP uses DHCP to assign your DNS servers. Your ISP automatically assigns this address.
- **Use These DNS Servers.** If you know that your ISP does not automatically transmit DNS addresses to the router during login, select this option, and enter the IP address of your ISP's primary DNS server. If a secondary DNS server address is available, enter it also.

**Router MAC Address.** The Ethernet MAC address used by the router on the Internet port. Some ISPs register the MAC address of the network interface card in your computer when your account is first opened. They will then accept traffic only from the MAC address of that computer. This feature allows your router to use your computer's MAC address (this is also called cloning).

- **Use Default Address.** Use the default MAC address.
- **Use Computer MAC Address.** The router will capture and use the MAC address of the computer that you are now using. You have to use the one computer that is allowed by the ISP.
- **Use This MAC Address.** Enter the MAC address that you want to use.

## Wireless Settings

The Wireless Settings screen lets you view or configure the wireless network setup.

The Mobile LTE Broadband 11n Wireless Router comes with preset security. This means that the Wi-Fi network name (SSID), network key (password), and security option (encryption protocol) are preset in the factory. You can find the preset SSID and password on the bottom of the unit.

---

**Note:** The preset SSID and password are uniquely generated for every device to protect and maximize your wireless security.

---

➤ **To view or change basic wireless settings:**

**NETGEAR recommends that you do not change your preset security settings.** If you do decide to change your preset security settings, make a note of the new settings and store it in a safe place where you can easily find it.

If you use a wireless computer to change the wireless network name (SSID) or other wireless security settings, you are disconnected when you click Apply. To avoid this problem, use a computer with a wired connection to access the router.

1. On the Basic Home screen, select **Wireless** to display the Wireless Settings screen.

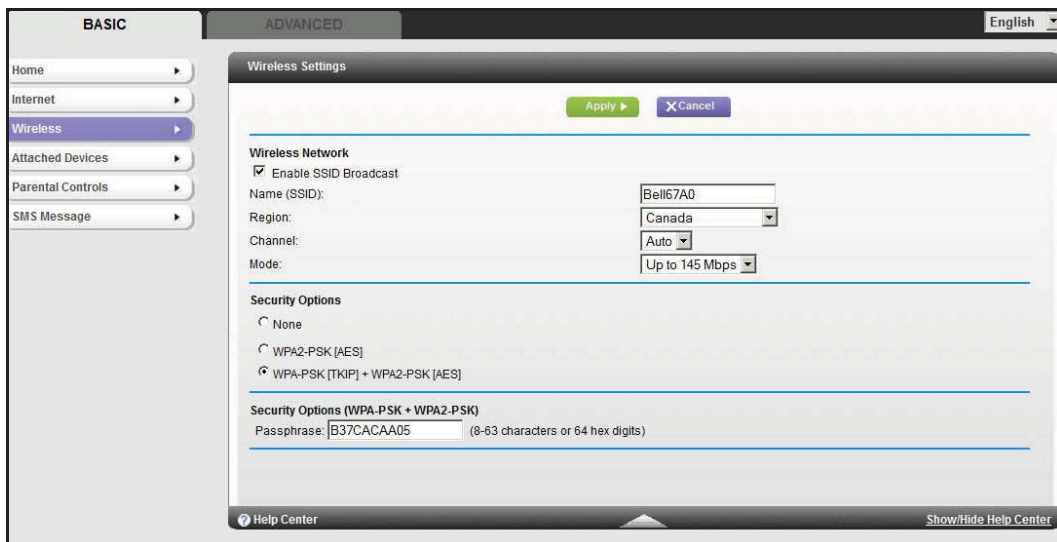

The screen sections, settings, and procedures are explained in the following sections.

2. Make any changes that are needed, and click **Apply** to save your settings.
3. Set up and test your wireless devices and computers to make sure that they can connect wirelessly. If they do not, check the following:



- Is your wireless device or computer connected to your network or another wireless network in your area? Some wireless devices automatically connect to the first open network (without wireless security) that they discover.
- Does your wireless device or computer show up on the Attached Devices screen? If it does, then it is connected to the network.
- If you are not sure what the network name (SSID) or password is, look on the label on the bottom of your router.

## Wireless Settings Screen Fields

### *Region Selection*

The location where the router is used. Select from the countries in the list. Note that in the United States, the region is fixed to United States and is not changeable.

### *Wireless Network (2.4 GHz b/g/n)*

The b/g/n and a/n notation references the 802.11 standards of conformance. For instance, the 2.4 b/g/n conforms to 802.11b, 802.11g, and 802.11n at 2.4 GHz radio frequency.

**Enable Wireless Isolation.** If this check box is selected, then wireless clients (computers or wireless devices) that join the network can use the Internet, but cannot access each other or access Ethernet devices on the network.

**Enable SSID Broadcast.** This setting allows the router to broadcast its SSID so wireless stations can see this wireless name (SSID) in their scanned network lists. This check box is selected by default. To turn off the SSID broadcast, clear the **Allow Broadcast of Name (SSID)** check box, and click **Apply**.

**Name (SSID).** The SSID is also known as the wireless network name. Enter a 32-character (maximum) name in this field. This field is case-sensitive. The default SSID is randomly generated, and **NETGEAR strongly recommends that you do not change this.**

**Channel.** This setting is the wireless channel used by the gateway. Enter a value from 1 through 13. (For products in the North America market, only Channels 1 through 11 can be operated.) Do not change the channel unless you experience interference (shown by lost connections or slow data transfers). If this happens, experiment with different channels to see which is the best.

**Mode.** Up to 217 Mbps is the default and allows 802.11n and 802.11g wireless devices to join the network. g & b supports up to 54 Mbps. The 450 Mbps setting allows 802.11n devices to connect at this speed.

### *Security Options Settings*

The Security Options section of the Wireless Settings screen lets you change the security option and passphrase. Please note that **NETGEAR recommends that you not change the security option or passphrase**, but if you want to change these settings, this section explains how. **Do not disable security.**

## Change WPA Security Option and Passphrase

1. Under Security Options, select the WPA option you want.

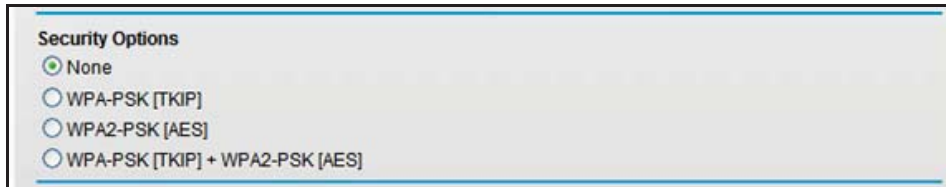

2. In the Passphrase field that displays when you select a WPA security option, enter the network key (passphrase) that you want to use. It is a text string from 8 to 63 characters.

## Attached Devices

You can view all computers or devices that are currently connected to your network here. From the Basic Home screen, select **Attached Devices** to display the following screen:

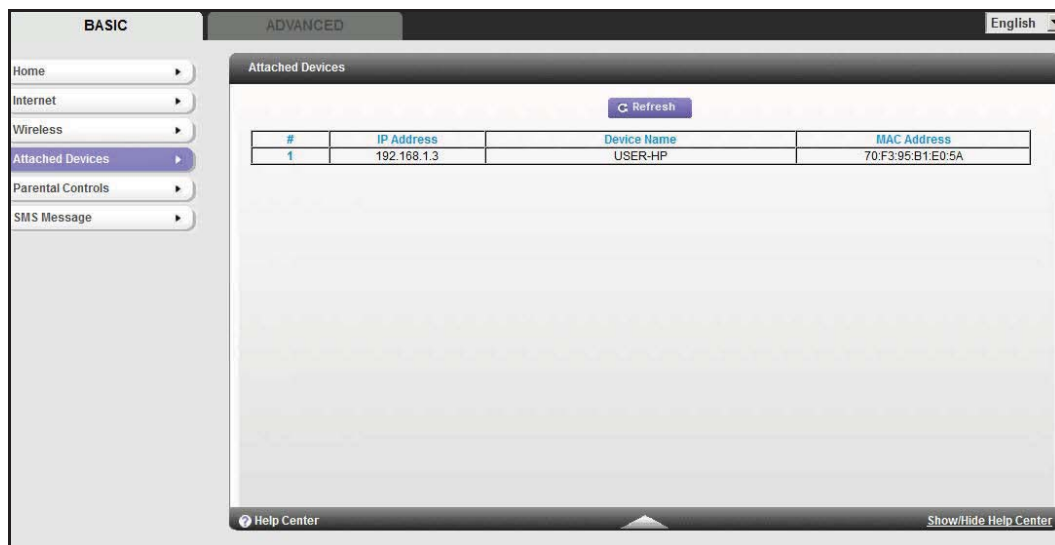

Wired devices are connected to the router with Ethernet cables. Wireless devices have joined the wireless network.

- **#** (number). The order in which the device joined the network.
- **IP Address**. The IP address that the router assigned to this device when it joined the network. Note that this number can change if a device is disconnected and rejoins the network.
- **MAC Address**. The unique MAC address for each device does not change. The MAC address is typically shown on the product label.
- **Device Name**. If the device name is known, it is shown here.

You can click **Refresh** to update this screen.

## Parental Controls

The first time you select Parental Controls from the Basic Home screen, you are automatically directed to the Internet, where you can learn more about Live Parental Controls or download the application. The following screen displays:



The screenshot shows the NETGEAR Parental Controls Center interface. At the top, there is a purple header with the NETGEAR logo and links for Support and Sign in. Below the header, the title "Parental Controls Center" is displayed. A sub-header reads "Use OpenDNS Parental Controls with your router to make the Internet safer for your household." To the left of this text is an image of a router and a laptop. Below the sub-header, there is a "Sign in to your OpenDNS account" section. This section contains two input fields: "Username" and "Password", followed by a "Sign in" button and a link for "Forgot your password?". To the right of the sign-in fields is an "Important Note" box. The note states: "If you have not yet configured the Live Parental Controls feature on your device please do so with the Management Utility found on the CD that came with your router or download it now for Windows or Mac." At the bottom left of the page, there is an OpenDNS logo and the copyright notice "© 2012 OpenDNS".

➤ **To set up Live Parental Controls:**

1. Select **Parental Controls** on the Dashboard screen.
2. Click either the **Windows Users** or **Mac Users** button.
3. Follow the onscreen instructions to download and install the NETGEAR Live Parental Controls Management Utility.

After installation, Live Parental Controls automatically starts.



4. Click **Next**, read the note, and click **Next** again to proceed.

Because Live Parental Controls uses free OpenDNS accounts, you are prompted to log in or create a free account.

### Setting up Live Parental Controls

Welcome, this setup wizard will quickly configure NETGEAR Live Parental Controls Powered by OpenDNS on your NETGEAR router.

In order to use Live Parental Controls, you need a free OpenDNS account. Do you already have one?

Yes, use my existing OpenDNS account.

No, I need to create a free OpenDNS account.

5. Select the radio button that applies to you and click **Next**.
  - If you already have an OpenDNS account, leave the **Yes** radio button selected.
  - If you do not have an OpenDNS account, select the **No** radio button.

If you are creating an account, the following screen displays:

### Create a free OpenDNS account

Username

Password

Confirm Password

Email

Confirm Email

- Fill in the fields and click **Next**.

After you log on or create your account, the filtering level screen displays:

### Live Parental Controls: choose a filtering level for your network

All computers connected to your router will be protected from the content you select below. You can customize your Live Parental Controls later on our website.

**High**  
Protects against all adult-related sites, illegal activity, social networking sites, video sharing sites, phishing attacks and general time-wasters.

**Moderate**  
Protects against all adult-related sites, illegal activity and phishing attacks.

**Low**  
Protects against pornography and phishing attacks.

**Minimal**  
Protects only against phishing attacks.

**None**  
Nothing blocked.

6. Select the radio button for the filtering level that you want and click **Next**.

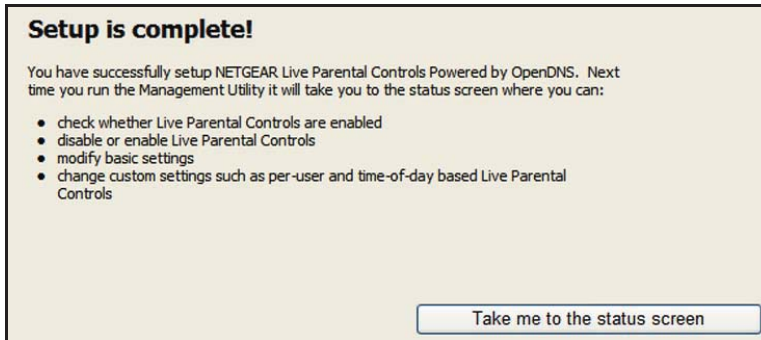

7. Click the **Take me to the status screen** button.

Parental controls are now set up for the router. The Dashboard shows Parental Controls as Enabled.

## SMS Message

Short Message Service (SMS) is a text messaging service for communication systems. The SMS screens enable you to perform the tasks that are explained in the following sections:

- [View SMS Messages](#)
- [Send SMS Messages](#)

### View SMS Messages

New SMS messages are available when the SMS LED on the front panel is solid green.

➤ **To view new SMS messages:**

1. Select **BASIC > SMS Message** to display the following screen:

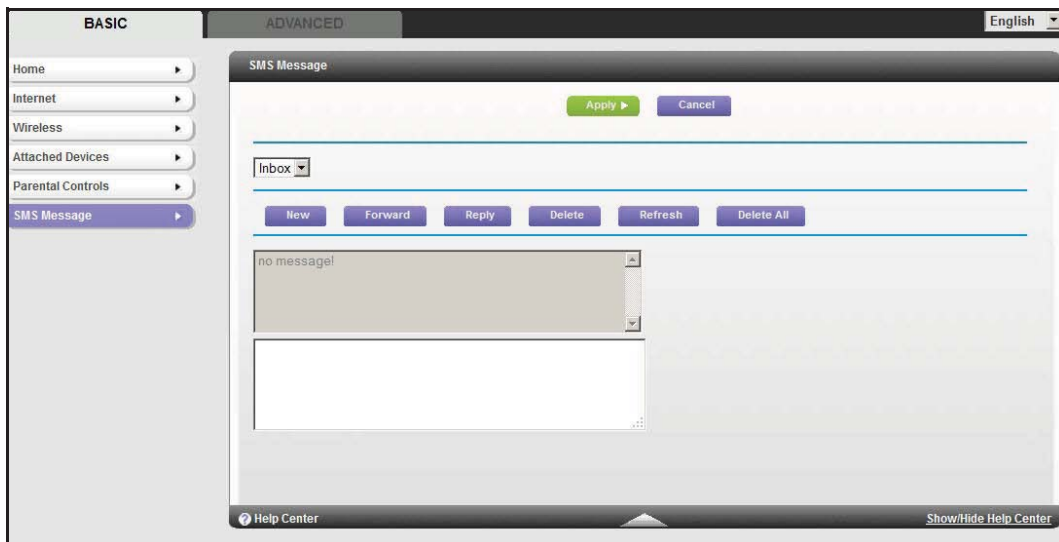

2. Click a particular message to view it.
  - Click **Forward** or **Reply** to forward or reply to the specified message.
  - Click **Delete** to delete the specified SMS message.
3. Otherwise, do one of the following:
  - Click **Refresh** to redisplay all SMS messages from the SIM card.
  - Click **Delete All** to delete all SMS messages from the SIM card
  - Click **New** to open a new message. See [Send SMS Messages](#) on page 31 for more information.

## Send SMS Messages

You can create a new SMS message or send an SMS message over email.

➤ **To send SMS messages:**

1. Select **BASIC > SMS Message** and then **New** to display the following screen:

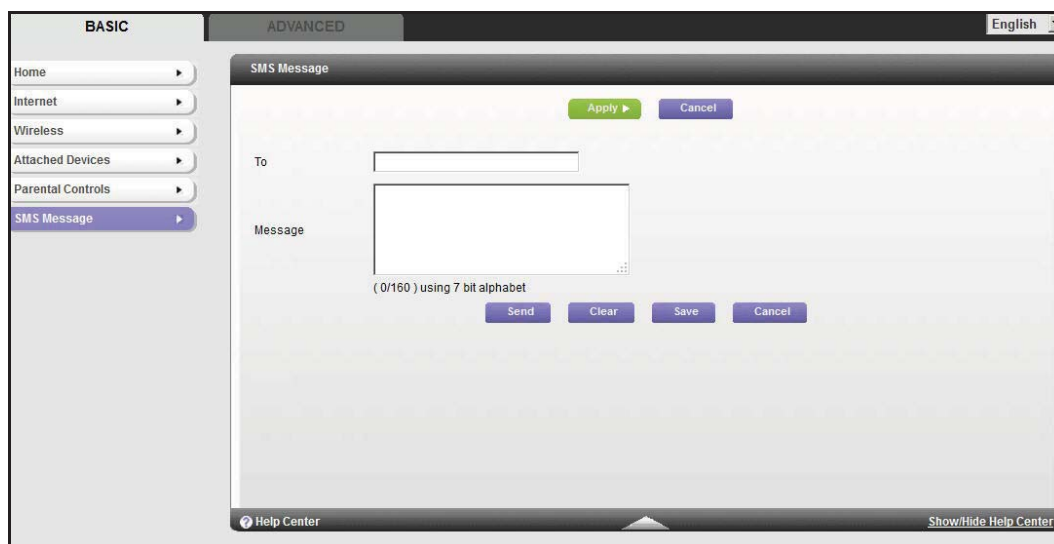
The screenshot shows the Netgear MBR1516 web interface. On the left is a navigation menu with 'BASIC' selected and 'SMS Message' highlighted. The main content area is titled 'SMS Message' and contains a form with a 'To' field, a 'Message' text area, and a character count '(0/160) using 7 bit alphabet'. At the top of the form are 'Apply' and 'Cancel' buttons. At the bottom are 'Send', 'Clear', 'Save', and 'Cancel' buttons. The interface also shows 'Home', 'Internet', 'Wireless', 'Attached Devices', and 'Parental Controls' options in the menu.

2. In the To field, enter the phone number that you want to send your SMS message to, or the email address to send a SMS message over email.

For multitarget messages, you can send a message to multiple phone numbers. Each phone number has to be separated by a comma (,).

3. In the Content field, enter the content of the SMS message. The length of the message is shown at the bottom of the content box.
4. Click **Send** to send the SMS message.

Alternatively, you can also take one of the following actions:

- Click **Clear** to remove the information in the To and Content fields.
- Click **Save** to save message to Draft.
- Click **Cancel** to return to the Inbox without sending the message.

# NETGEAR genie Advanced Home

# 4

## Specifying custom settings

This chapter explains the features available from the NETGEAR genie Advanced Home screen, shown in the following figure:

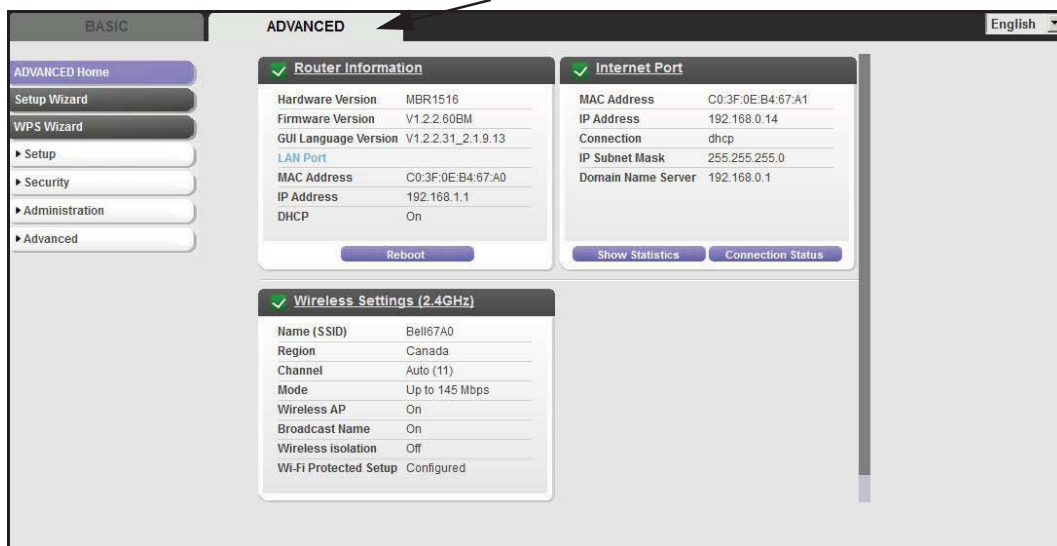

This chapter contains the following sections:

- [Setup Wizard](#)
- [WPS Wizard](#)
- [Setup Menu](#)

Some selections on the Advanced Home screen are described in separate chapters:

- **Security.** See [Chapter 5, Security](#).
- **Administration.** See [Chapter 6, Administration](#).
- **Advanced Setup.** See [Chapter 7, Advanced Settings](#).



## Setup Wizard

The NETGEAR genie installation process is launched the first time you set up the router. After setting up the router the first time, if you want to perform this task again, you can run Setup Wizard from the Advanced tab of the NETGEAR genie.

➤ **To run the Setup Wizard:**

1. Select **ADVANCED > Setup Wizard** to display the following screen:

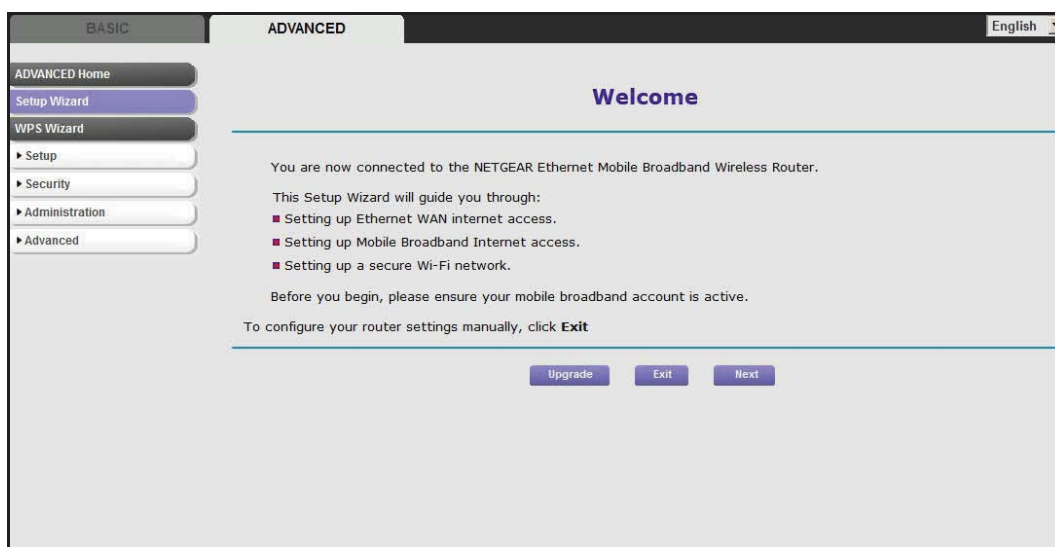

2. Click **Upgrade** to update the firmware (see [Router Upgrade](#) on page 63). Otherwise, click **Next** to continue.
3. Select your broadband settings (see [Broadband Settings](#) on page 36) and click **Next**.

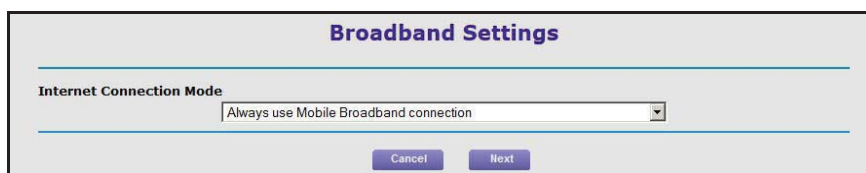

The router provides you with a update progress indication.

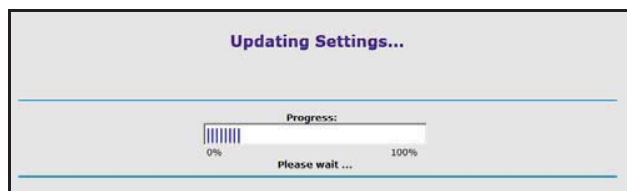

---

**Note:** When you run the Setup Wizard from a WiFi connection, you are logged out when the router reboots.

---

## WPS Wizard

The WPS Wizard helps you add a WPS-capable client device (a wireless device or computer) to your network. On the client device you need to either press its WPS button or locate its WPS PIN.

➤ **To use the WPS Wizard:**

1. Select **ADVANCED > WPS Wizard**.
2. Click **Next**. The following screen lets you select the method for adding the WPS client (a wireless device or computer).

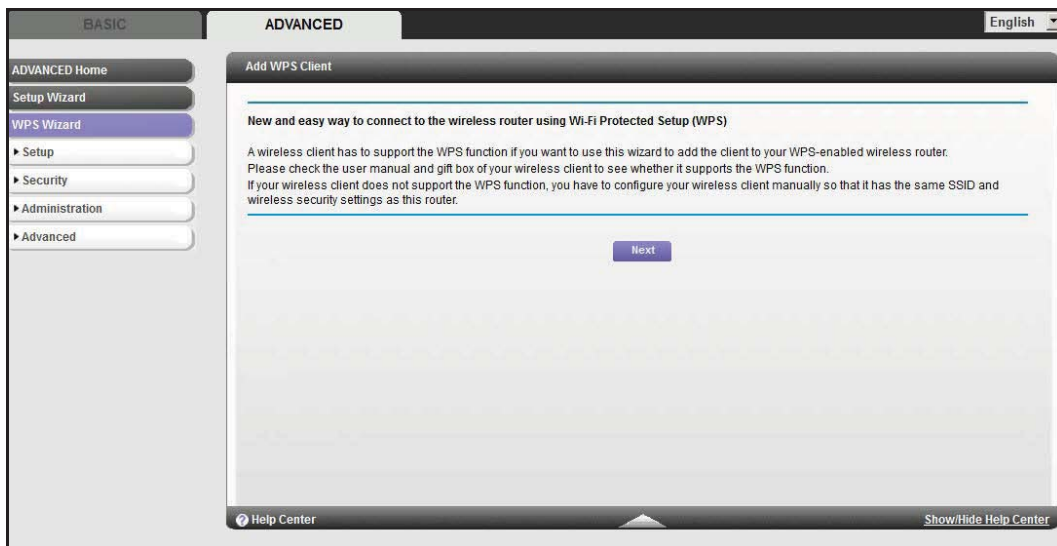

You can use either the push button or PIN method.

3. Select either **Push Button** or **PIN Number**.

- To use the push button method, either click the **WPS** button on this screen, or press the **WPS** button located on the side of the router. Within 2 minutes, go to the wireless client and press its **WPS** button to join the network without entering a password.

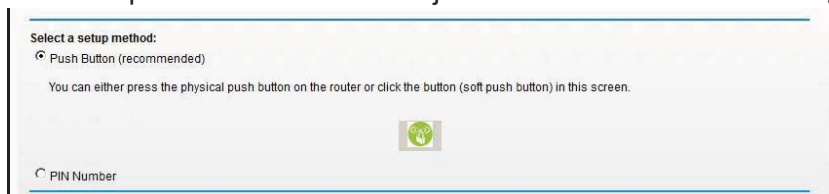

- To use the PIN method, select the **PIN Number** radio button, enter the client security PIN, and click **Next**.

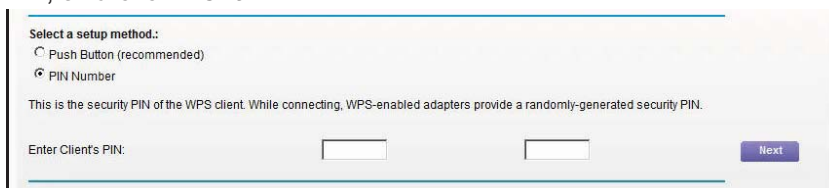

Within 2 minutes, go to the client device and use its WPS software to join the network without entering a password.

The router attempts to add the WPS-capable device. The WPS LED on the front of the router blinks green. When the router establishes a WPS connection, the LED is solid green, and the router WPS screen displays a confirmation message.

4. Repeat Step 2 and Step 3 to add another WPS client to your network.

## Setup Menu

Select **ADVANCED > Setup** to display the Setup menu. The following selections are available:

- **Broadband Settings.** Configure the Internet connection mode of your Mobile LTE Broadband 11n Wireless Router MBR1516. See [Broadband Settings](#) on page 36.
- **Mobile Broadband Settings.** Configure the access to your mobile broadband account. See [Mobile Broadband Settings](#) on page 36.
- **Ethernet Broadband Settings.** This is a shortcut to the same Internet Setup screen that you can access from the dashboard on the Basic Home screen. See [Internet Setup](#) on page 22.
- **Wireless Setup.** This is a shortcut to the same Wireless Settings screen that you can access from the dashboard on the Basic Home screen. See [Wireless Settings](#) on page 24.
- **WAN Setup.** Internet (WAN) setup. See [WAN Setup](#) on page 38.
- **LAN Setup.** Local area network (LAN) setup. See [LAN Setup](#) on page 41.
- **QoS Setup.** Quality of Service (QoS) setup. See [Quality of Service \(QoS\) Setup](#) on page 44.

## Broadband Settings

The Broadband Settings screen lets you select the Internet connection mode of your Mobile LTE Broadband 11n Wireless Router MBR1516.

➤ **To select your Internet connection mode:**

1. Select **ADVANCED > Setup > Broadband Settings** to view the following screen:

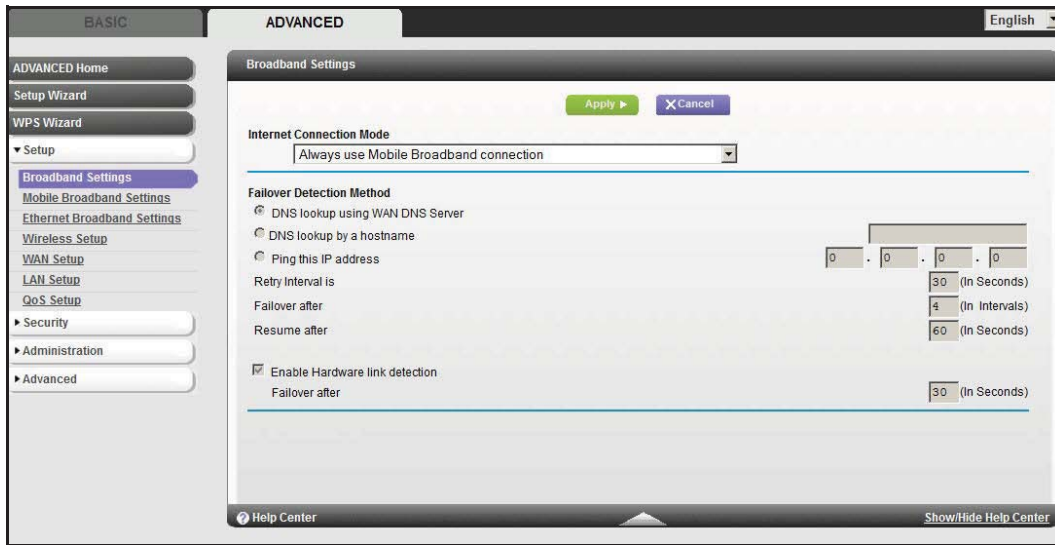

Your Internet connection choices include the following:

- Use Ethernet connection first and if fail use mobile broadband connection
- Always use Mobile Broadband connection
- Always use Ethernet connection

2. Click **Apply** to save your selection.

## Mobile Broadband Settings

The Mobile Broadband Settings screen lets you configure the access to your mobile broadband account.

---

**Note:** To connect to the mobile broadband network requires an active broadband service account. Contact your ISP for your user name, password, and the network name.

---

➤ To configure your mobile broadband account access:

1. Select **ADVANCED > Setup > Mobile Broadband Settings** to view the following screen:

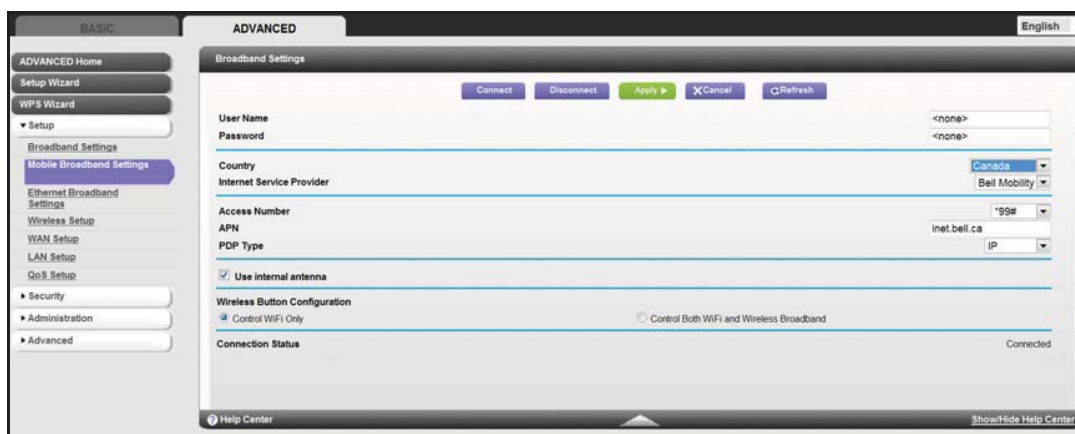

The following settings are provided:

- **User Name.** The account login user name.
  - **Password.** The account password for authentication.
  - **Country.** The country where mobile broadband service is provided.
  - **Internet Service Provider.** The Internet Service Provider of the 3G network.
  - **PIN code.** The PIN code of the SIM card.
  - **APN.** The access point name.
  - **Access Number.** The phone number of the remote site.
  - **PDP Type.** The type of packet data protocol.
  - **Use internal antenna.** The Mobile LTE Broadband 11n Wireless Router MBR1516 uses internal antennas unless you choose to boost reception with external antennas. See [Use external antennas for improved signal strength](#). on page 94.
  - **Wireless Button Configuration.** Choose whether you want the WPS button to control WiFi only or both WiFi and wireless broadband.
  - **Connection Status.** The status of the current WAN port.
2. Click **Apply** to save your settings.
  3. Click **Connect** when you want to connect manually to the network.
  4. Click **Disconnect** when you want to disconnect manually from the current network.

## WAN Setup

The WAN Setup screen lets you configure a DMZ (demilitarized zone) server, change the Maximum Transmit Unit (MTU) size, and enable the router to respond to a ping on the WAN (Internet) port. Select **ADVANCED > Setup > WAN Setup** to view the following screen:

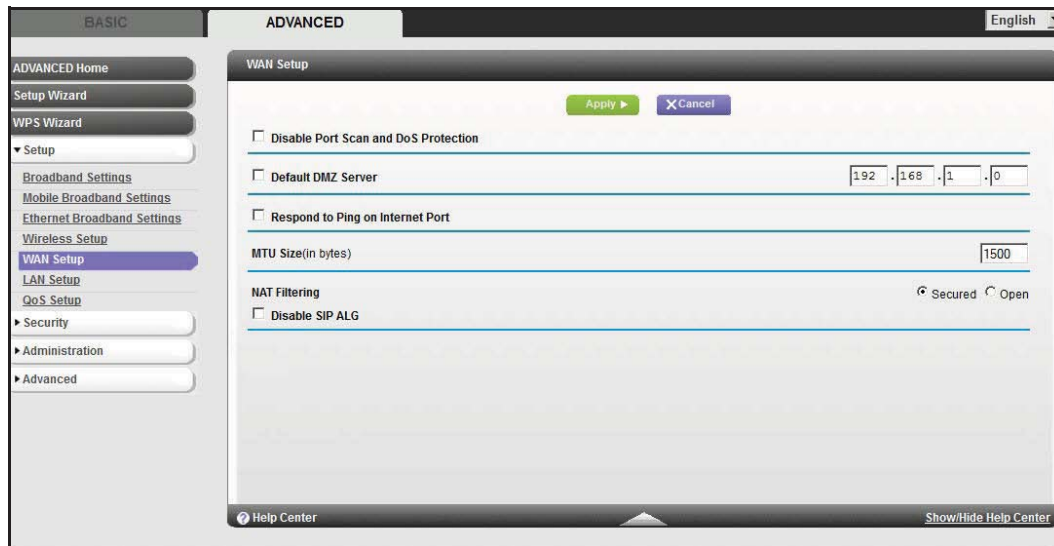

- **Disable Port Scan and DoS Protection.** DoS protection protects your LAN against denial of service attacks such as Syn flood, Smurf Attack, Ping of Death, Teardrop Attack, UDP Flood, ARP Attack, Spoofing ICMP, Null Scan, and many others. This should be disabled only in special circumstances.
- **Default DMZ Server.** This feature is sometimes helpful when you are playing online games or videoconferencing. Be careful when using this feature because it makes the firewall security less effective. See [Default DMZ Server](#) on page 39 for more details.
- **Respond to Ping on Internet Port.** If you want the router to respond to a ping from the Internet, select this check box. Use this only as a diagnostic tool because it allows your router to be discovered. Do not select this check box unless you have a specific reason.
- **MTU Size (in bytes).** The normal MTU (Maximum Transmit Unit) value for most Ethernet networks is 1500 bytes, or 1492 bytes for PPPoE connections. For some ISPs you might need to reduce the MTU. This is rarely required, and should not be done unless you are sure it is necessary for your ISP connection. See [Change the MTU Size](#) on page 39.
- **NAT Filtering.** Network Address Translation (NAT) determines how the router processes inbound traffic. Secured NAT provides a secured firewall to protect the computers on the LAN from attacks from the Internet, but might prevent some Internet games, point-to-point applications, or multimedia applications from functioning. Open NAT provides a much less secured firewall, but allows almost all Internet applications to function.
- **Disable SIP ALG.** Some VoIP applications do not work well with the SIP ALG. Enabling this option to turn off the SIP ALG helps your VoIP devices create and accept calls through the router.

## Default DMZ Server

The default DMZ server feature is helpful when you are using some online games and videoconferencing applications that are incompatible with Network Address Translation (NAT). The router is programmed to recognize some of these applications and to work correctly with them, but there are other applications that might not function well. In some cases, one local computer can run the application correctly if that computer's IP address is entered as the default DMZ server.



### **WARNING:**

**DMZ servers pose a security risk. A computer designated as the default DMZ server loses firewall protection from exploits on the Internet. Once compromised, the DMZ server computer attacks other computers on your network.**

Incoming traffic from the Internet is usually discarded by the router unless the traffic is a response to one of your local computers or a service that you have configured in the Port Forwarding/Port Triggering screen. Instead of discarding this traffic, you can have it forwarded to one computer on your network. This computer is called the default DMZ server.

#### ➤ **To set up a default DMZ server:**

1. On the WAN Setup screen, select the **Default DMZ Server** check box.
2. Type the IP address.
3. Click **Apply**.

## Change the MTU Size

The Maximum Transmission Unit (MTU) is the largest data packet a network device transmits. When one network device communicates across the Internet with another, the data packets travel through many devices along the way. If any device in the data path has a lower MTU setting than the other devices, the data packets have to be split or "fragmented" to accommodate the device with the smallest MTU.

The best MTU setting for NETGEAR equipment is often just the default value, and changing the value might fix one problem but cause another. Leave MTU unchanged unless one of these situations occurs:

- You have problems connecting to your ISP or other Internet service, and the technical support of either the ISP or NETGEAR recommends changing the MTU setting. These web-based applications might require an MTU change:
  - A secure website that will not open, or displays only part of a web page
  - Yahoo email
  - MSN portal
  - America Online's DSL service

- You use VPN and have severe performance problems.
- You used a program to optimize MTU for performance reasons, and now you have connectivity or performance problems.

---

**Note:** An incorrect MTU setting causes Internet communication problems such as the inability to access certain websites, frames within websites, secure login pages, and FTP or POP servers.

---

If you suspect an MTU problem, a common solution is to change the MTU to 1400. If you are willing to experiment, you can gradually reduce the MTU from the maximum value of 1500 until the problem goes away. The following table describes common MTU sizes and applications.

**Table 2. Common MTU Sizes**

MTU	Application
1500	The largest Ethernet packet size and the default value. This is the typical setting for non-PPPoE, non-VPN connections, and is the default value for NETGEAR routers, adapters, and switches.
1492	Used in PPPoE environments.
1472	Maximum size to use for pinging. (Larger packets are fragmented.)
1468	Used in some DHCP environments.
1460	Usable by AOL if you do not have large email attachments, for example.
1436	Used in PPTP environments or with VPN.
1400	Maximum size for AOL DSL.
576	Typical value to connect to dial-up ISPs.

➤ **To change the MTU size:**

1. Select **ADVANCED > Setup > WAN Setup**.
2. In the MTU Size field, enter a new size between 64 and 1500.
3. Click **Apply** to save the settings.



## LAN Setup

The LAN Setup screen allows configuration of LAN IP services such as Dynamic Host Configuration Protocol (DHCP) and Routing Information Protocol (RIP).

The router is shipped preconfigured to use private IP addresses on the LAN side and to act as a DHCP server. The router's default LAN IP configuration is:

- LAN IP address. **192.168.0.1**
- Subnet mask. **255.255.255.0**

These addresses are part of the designated private address range for use in private networks and should be suitable for most applications. If your network has a requirement to use a different IP addressing scheme, you can make those changes in the LAN Setup screen.

---

**Note:** If you change the LAN IP address of the router while connected through the browser, you will be disconnected. You will have to open a new connection to the new IP address and log in again.

---

### ➤ To change the LAN settings:

1. Select **ADVANCED > Setup > LAN Setup** to display the following screen:

2. Enter the settings that you want to customize. These settings are described in [LAN Setup Screen Settings](#) on page 42.
3. Click **Apply** to save your changes.

## LAN Setup Screen Settings

### *LAN TCP/IP Setup*

- **IP Address.** The LAN IP address of the router.
- **IP Subnet Mask.** The LAN subnet mask of the router. Combined with the IP address, the IP subnet mask allows a device to know which other addresses are local to it, and which have to be reached through a gateway or router.
- **RIP Direction.** Router Information Protocol (RIP) allows a router to exchange routing information with other routers. This setting controls how the router sends and receives RIP packets. Both is the default setting. With the Both or Out Only setting, the router broadcasts its routing table periodically. With the Both or In Only setting, the router incorporates the RIP information that it receives.
- **RIP Version.** This controls the format and the broadcasting method of the RIP packets that the router sends. It recognizes both formats when receiving. By default, the RIP function is disabled.

**RIP-1** is universally supported. It is adequate for most networks, unless you have an unusual network setup.

**RIP-2** carries more information. Both RIP-2B and RIP-2M send the routing data in RIP-2 format. RIP-2B uses subnet broadcasting. RIP-2M uses multicasting.

### *Use Router as a DHCP Server*

This check box is usually selected so that the router functions as a Dynamic Host Configuration Protocol (DHCP) server.

- **Starting IP Address.** Specify the start of the range for the pool of IP addresses in the same subnet as the router.
- **Ending IP Address.** Specify the end of the range for the pool of IP addresses in the same subnet as the router.

### *Address Reservation*

When you specify a reserved IP address for a computer on the LAN, that computer receives the same IP address each time it accesses the router's DHCP server. Assign reserved IP addresses to servers that require permanent IP settings.

## Use the Router as a DHCP Server

By default, the router functions as a DHCP server, allowing it to assign IP, DNS server, and default gateway addresses to all computers connected to the router's LAN. The assigned default gateway address is the LAN address of the router. The router assigns IP addresses to the attached computers from a pool of addresses specified in this screen. Each pool address is tested before it is assigned to avoid duplicate addresses on the LAN. For most applications, the default DHCP and TCP/IP settings of the router are satisfactory.

You can specify the pool of IP addresses to be assigned by setting the starting IP address and ending IP address. These addresses should be part of the same IP address subnet as the router's LAN IP address. Using the default addressing scheme, you should define a range between 192.168.1.2 and 192.168.1.254, although you might want to save part of the range for devices with fixed addresses.

The router delivers the following parameters to any LAN device that requests DHCP:

- An IP address from the range you have defined
- Subnet mask
- Gateway IP address (the router's LAN IP address)
- Primary DNS server (if you entered a primary DNS address in the Internet Setup screen; otherwise, the router's LAN IP address)
- Secondary DNS server (if you entered a secondary DNS address in the Internet Setup screen)

To use another device on your network as the DHCP server, or to manually configure the network settings of all of your computers, clear the **Use Router as DHCP Server** check box and click **Apply**. Otherwise, leave this check box selected. If this service is not enabled and no other DHCP server is available on your network, you need to set your computers' IP addresses manually or they will not be able to access the router.

## Address Reservation

When you specify a reserved IP address for a computer on the LAN, that computer always receives the same IP address each time it accesses the router's DHCP server. Reserved IP addresses should be assigned to computers or servers that require permanent IP settings.

### ➤ To reserve an IP address:

1. In the Address Reservation section of the screen, click the **Add** button to display the following screen:

The screenshot shows the 'Address Reservation' configuration window. At the top, there are three buttons: '+ Add' (green), 'X Cancel' (purple), and 'C Refresh' (purple). Below the buttons is a table titled 'Address Reservation Table' with the following data:

#	IP Address	Device Name	MAC Address
1	192.168.1.3	USER-HP	70:f3:95:b1:e0:5a

Below the table, there are three input fields: 'IP Address' (with a dotted decimal mask showing 192.168.1.), 'MAC Address', and 'Device Name'.

2. In the IP Address field, type the IP address to assign to the computer or server. (Choose an IP address from the router's LAN subnet, such as 192.168.1.x.)
3. Type the MAC address of the computer or server.

**Tip:** If the computer is already on your network, you can copy its MAC address from the Attached Devices screen and paste it here.

4. Click **Apply** to enter the reserved address into the table.

The reserved address is not assigned until the next time the computer contacts the router's DHCP server. Reboot the computer, or access its IP configuration and force a DHCP release and renew.

To edit or delete a reserved address entry, select the radio button next to the reserved address you want to edit or delete. Then click **Edit** or **Delete**.

## Quality of Service (QoS) Setup

QoS is an advanced feature that can be used to prioritize some types of traffic ahead of others. The Mobile LTE Broadband 11n Wireless Router can provide QoS prioritization over the wireless link and on the Internet connection. To configure QoS, use the QoS Setup screen.

Select **ADVANCED > Setup > QoS Setup** to display the following screen:

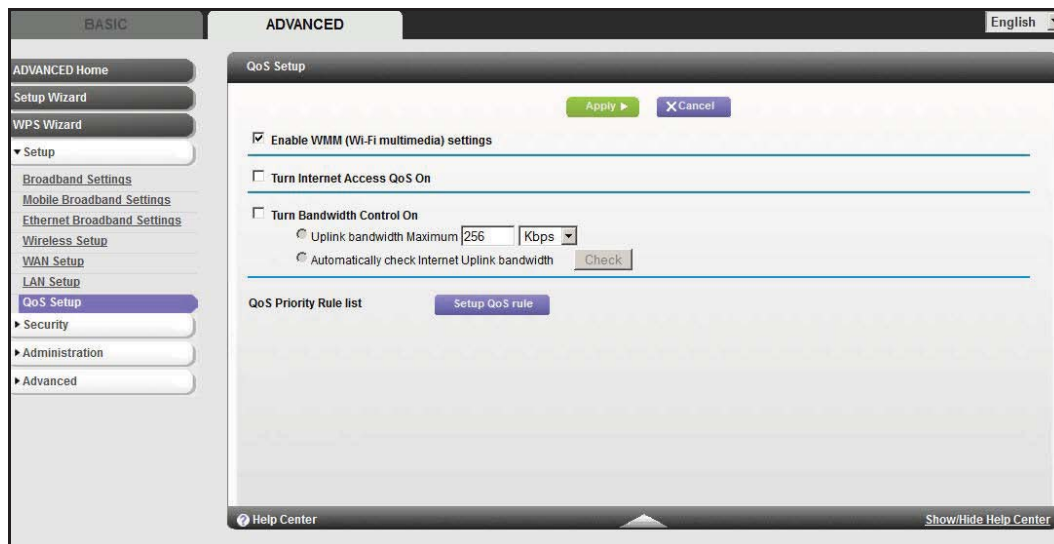

### *Enable WMM QoS for Wireless Multimedia Applications*

WMM (Wireless Multimedia) is a subset of the 802.11e standard. WMM allows wireless traffic to have a range of priorities depending on the type of data. Time-dependent information, such as video and audio, has a higher priority than normal traffic. For WMM to function correctly, wireless clients have to support WMM also.

WMM QoS is enabled by default. You can disable it in the QoS Setup screen by clearing the **Enable WMM** check box and clicking **Apply**.

### *Turn Internet Access QoS On*

Enable this feature for the QoS function to prioritize Internet traffic.

### Manage the QoS Priority Rules

Select **ADVANCED > Setup > QoS Setup > Setup QoS rule** to display the following screen:

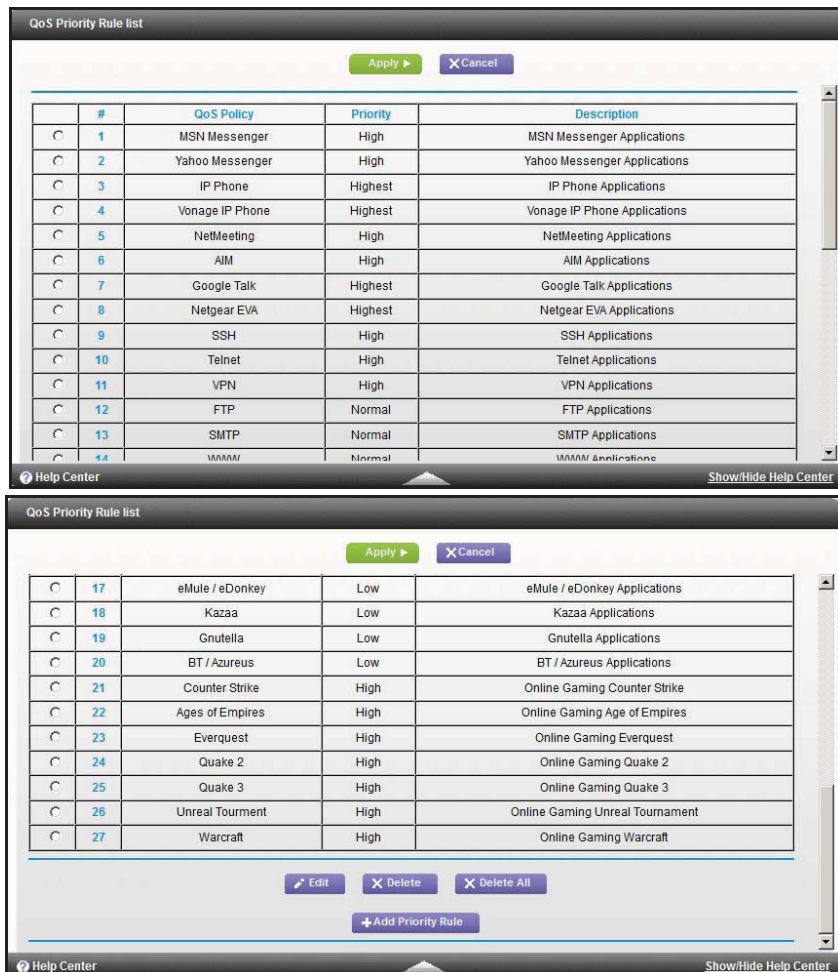

For applications such as online gaming, an Ethernet LAN port, or a specified MAC address that already appear in the list, modify the priority level by selecting it, and then clicking **Edit**. Click **Delete** to erase the priority rule.

You can also define the priority policy for each online game, application, LAN port, or the computer's MAC address by clicking **Add Priority Rule**.

QoS - Priority Rules

Apply Cancel

Priority

QoS Policy for

Priority Category Applications

Applications Add a new application

Priority Normal

Specified Port Range

Connection Type TCP/UDP

Starting Port (1-65535)

Ending Port (1-65535)

### For Applications or Online Gaming

➤ To set up the priority for an application or online gaming:

1. Select **Applications** or **Online Gaming** from the Priority Category list.

QoS - Priority Rules

Apply Cancel

Priority

QoS Policy for

Priority Category Applications

Applications Add a new application

Priority Normal

Specified Port Range

Connection Type TCP/UDP

Starting Port (1-65535)

Ending Port (1-65535)

Help Center Show/Hide Help Center

QoS - Priority Rules

Apply Cancel

Priority

QoS Policy for

Priority Category Online Gaming

Applications Add a new game

Priority Normal

Specified Port Range

Connection Type TCP/UDP

Starting Port (1-65535)

Ending Port (1-65535)

Help Center Show/Hide Help Center

2. Select the Internet application or game from one of the lists.

3. Select the priority level: Highest, High, Normal, or Low.
4. Type the name in the QoS Policy for field for this rule.
5. Click **Apply**.

*For an Ethernet LAN Port*

➤ **To set up the priority for computers connected to a LAN port:**

1. Select **Ethernet LAN Port** from the Priority Category list.

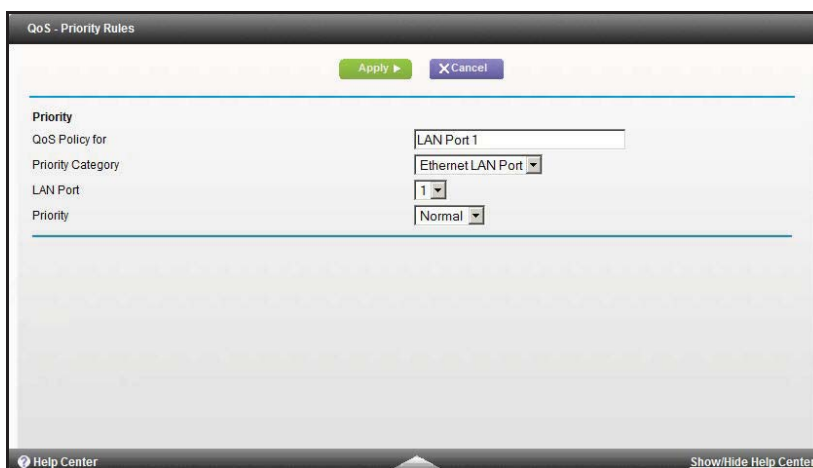

2. Select the number of the LAN port for which you want to specify the priority level.
3. Select the priority level: Highest, High, Normal, or Low.
4. You can also type the name in the QoS Policy for field for this rule.
5. Click **Apply**.

*For a MAC Address*

➤ **To set up the priority for a specified computer through its MAC address:**

1. Select MAC Address from the Priority Category list.

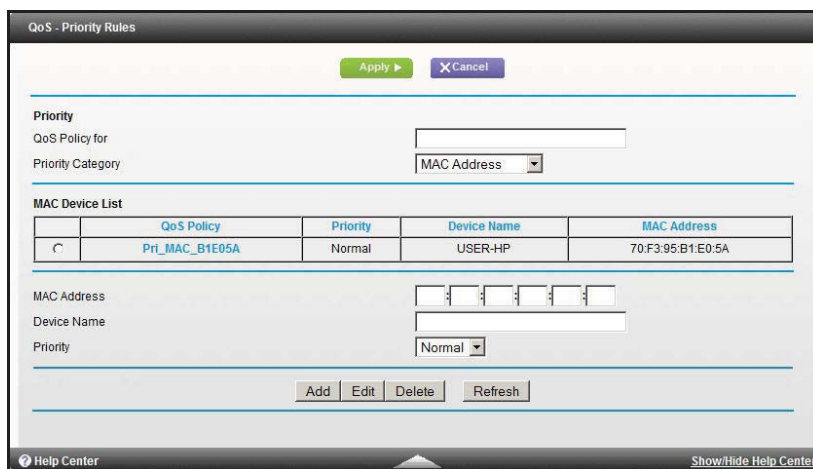

2. Click **Refresh** to update the list of those computers already connected to the router.
3. Select the entry's radio button in the table.
4. Modify the information in the MAC Address and Device Name fields.
5. Select the priority level: Highest, High, Normal, or Low.
6. You can also type the name in the QoS Policy for field for this rule.
7. Click **Edit** or **Add**.
8. Click **Apply**.

### *Editing or Deleting an Existing QoS Policy*

➤ **To edit or delete a QoS policy:**

1. Select **ADVANCED > QoS Setup** to display the QoS Setup screen.
2. Select the radio button next to the QoS policy to be edited or deleted, and do one of the following:
  - Click **Delete** to remove the QoS policy.
  - Click **Edit** to edit the QoS policy. Follow the instructions in the preceding sections to change the policy settings.
3. Click **Apply** in the QoS Setup screen to save your changes.



# 5 Security

---

# 5

## Keeping unwanted content out of your network

This chapter explains how to use the basic firewall features of the router to prevent objectionable content from reaching the computers and other devices connected to your network.

This chapter includes the following sections:

- *Keyword Blocking of HTTP Traffic*
- *Block Services (Port Filtering)*
- *Schedule Blocking*
- *Security Event Email Notifications*

## Keyword Blocking of HTTP Traffic

Use keyword blocking to prevent certain types of HTTP traffic from accessing your network. The blocking can be always or according to a schedule.

1. Select **ADVANCED > Security > Block Sites** to display the following screen:

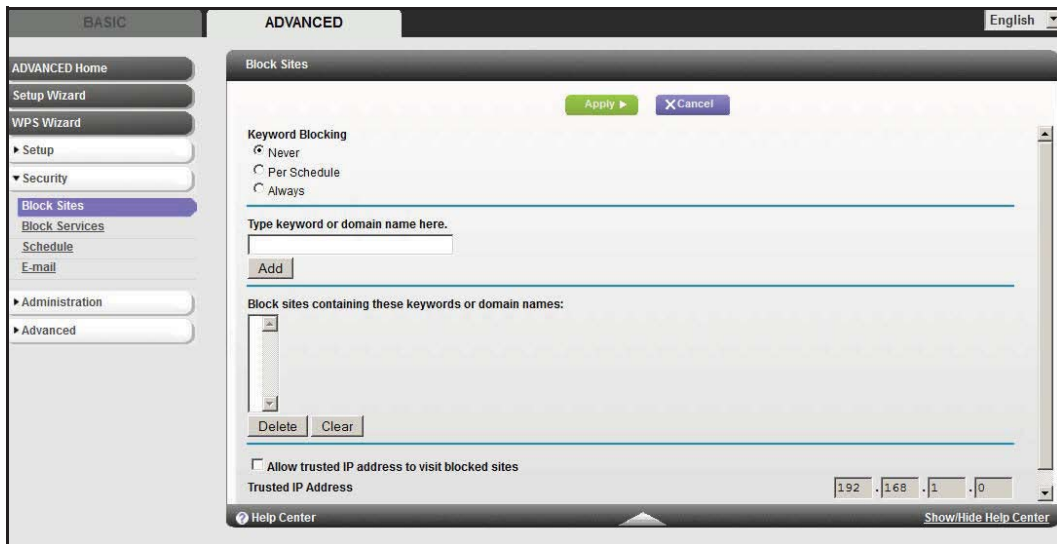

2. Select one of the keyword blocking options:
  - **Per Schedule.** Turn on keyword blocking according to the Schedule screen settings.
  - **Always.** Turn on keyword blocking all the time, independent of the Schedule screen.
3. In the Keyword field, enter a keyword or domain, click **Add Keyword**, and click **Apply**.  
The Keyword list supports up to 32 entries. Here are some sample entries:
  - Specify XXX to block http://www.badstuff.com/xxx.html.
  - Specify .com if you want to allow only sites with domain suffixes such as .edu or .gov.
  - Enter a period (.) to block all Internet browsing access.

➤ **To delete a keyword or domain:**

1. Select the keyword you want to delete from the list.
2. Click **Delete Keyword**, and then **Apply** to save your changes.

➤ **To specify a trusted computer:**

You can exempt one trusted computer from blocking and logging. The computer you exempt has to have a fixed IP address.

1. In the Trusted IP Address field, enter the IP address.
2. Click **Apply** to save your changes.

## Block Services (Port Filtering)

Services are functions performed by server computers at the request of client computers. For example, web servers serve web pages, time servers serve time and date information, and game hosts serve data about other players' moves. When a computer on the Internet sends a request for service to a server computer, the requested service is identified by a service or port number. This number appears as the destination port number in the transmitted IP packets. For example, a packet that is sent with the destination port number 80 is an HTTP (web server) request.

The service numbers for many common protocols are defined by the Internet Engineering Task Force (IETF at <http://www.ietf.org/>) and published in RFC1700, "Assigned Numbers." Service numbers for other applications are typically chosen from the range 1024 to 65535 by the authors of the application. Although the router already holds a list of many service port numbers, you are not limited to these choices. You can often determine port number information by contacting the publisher of the application, by asking user groups or newsgroups, or by searching.

The Block Services screen lets you add and block specific Internet services by computers on your network. This is called service blocking or port filtering. To add a service for blocking, first determine which port number or range of numbers are used by the application.

### ➤ To block services:

1. Select **ADVANCED > Security > Block Services** to display the following screen:

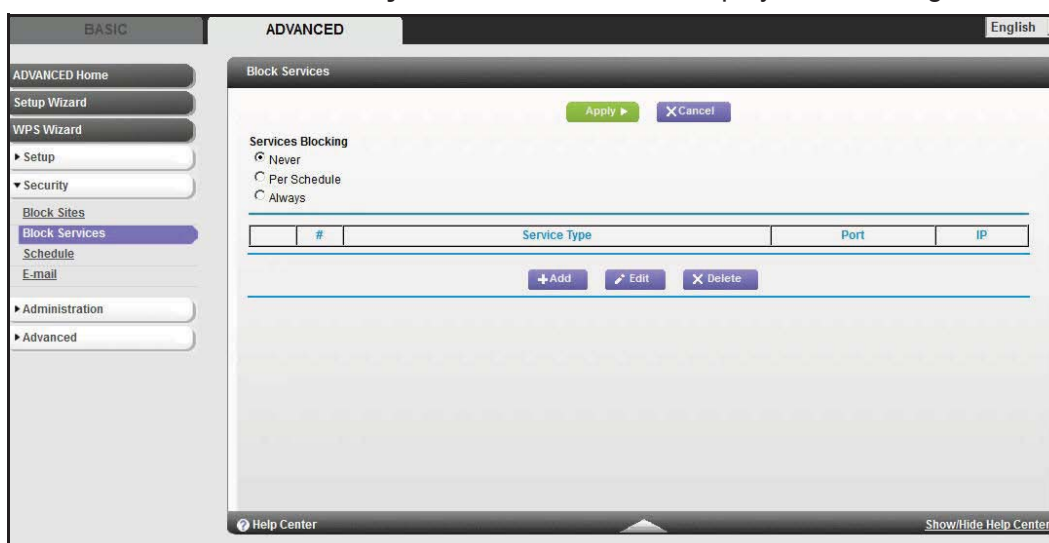

2. Select either **Per Schedule** or **Always** to enable service blocking, and click **Apply**. If you selected **Per Schedule**, specify a time period in the **Schedule** screen as described in [Schedule Blocking](#) on page 53.

3. Click **Add** to add a service. The Block Services Setup screen displays:

The screenshot shows the 'Block Services Setup' interface. At the top, there are 'Apply' and 'Cancel' buttons. The main area contains the following fields:

- Service Type:** A dropdown menu with 'User Defined' selected.
- Protocol:** A dropdown menu with 'TCP' selected.
- Starting Port:** A text input field with '(1~65534)' as a hint.
- Ending Port:** A text input field with '(1~65534)' as a hint.
- Service Type/User Defined:** A text input field.

Below these fields is a section titled 'Filter Services For:' with three radio button options:

- Only This IP Address: followed by four input fields for IP address (192, 168, 1, and an empty field).
- IP Address Range: followed by two sets of four input fields for IP address range (192, 168, 1, empty) and 'to' (192, 168, 1, empty).
- All IP Addresses

At the bottom of the window, there are links for 'Help Center' and 'Show/Hide Help Center'.

4. From the Service Type list, select the application or service to allow or block. The list already displays several common services, but you are not limited to these choices. To add any additional services or applications that do not already appear, select **User Defined**.
5. If you know that the application uses either TCP or UDP, select the appropriate protocol. If you are not sure, select **Both**.
6. Enter the starting and ending port numbers. If the application uses a single port number, enter that number in both fields.
7. Select the radio button for the IP address configuration you want to block, and enter the IP addresses. You can block the specified service for a single computer, a range of computers with consecutive IP addresses, or all computers on your network.
8. Click **Add** to enable your Block Services Setup selections.

## Schedule Blocking

You can specify the days and time that you want to block Internet access.

➤ **To schedule blocking:**

1. Select **ADVANCED > Security > Schedule** to display the following screen:

The screenshot shows the 'Schedule' configuration page in the router's web interface. The interface is divided into two main sections: 'BASIC' and 'ADVANCED'. The 'ADVANCED' section is active, and the 'Schedule' page is displayed. The page has a dark header with 'Apply' and 'Cancel' buttons. The main content area is titled 'Schedule' and contains the following settings:

- Days to Block:** A list of days with checkboxes:  Every Day,  Sunday,  Monday,  Tuesday,  Wednesday,  Thursday,  Friday, and  Saturday.
- Time of day to block:(use 24-hour clock)**
  - All Day
  - Start Blocking: 0 Hour 0 Minute
  - End Blocking: 24 Hour 0 Minute
- Time Zone:** A dropdown menu showing '(GMT-05:00) Bogota, Lima, Quito, Eastern Time (US & Canada)'. Below it is a checked checkbox for 'Automatically adjust for daylight savings time'.

At the bottom of the page, there are links for 'Help Center' and 'Show/Hide Help Center'.

2. Set up the schedule for blocking keywords and services.
  - **Days to Block.** Select days on which you want to apply blocking by selecting the appropriate check boxes, or select **Every Day** to select the check boxes for all days.
  - **Time of Day to Block.** Select a start and end time in 24-hour format, or select **All Day** for 24-hour blocking.
3. Select your time zone from the list. If you use daylight savings time, select the **Automatically adjust for daylight savings time** check box.
4. Click **Apply** to save your settings.

## Security Event Email Notifications

To receive logs and alerts by email, provide your email information in the Email screen, and specify which alerts you want to receive and how often.

➤ **To set up email notifications:**

1. Select **ADVANCED > Security > Email** to display the following screen:

2. To receive email logs and alerts from the router, select the **Turn Email Notification On** check box.
3. In the Your Outgoing Mail Server field, enter the name of your ISP's outgoing (SMTP) mail server (such as mail.myISP.com). You might be able to find this information in the configuration screen of your email program. If you leave this field blank, log and alert messages are not sent by email.
4. Enter the email address to which logs and alerts are sent in the Send to This Email Address field. This email address is also used for the From address. If you leave this field blank, log and alert messages are not sent by email.
5. If your outgoing email server requires authentication, select the **My Mail Server requires authentication** check box. Fill in the User Name and Password fields for the outgoing email server.
6. You can have email alerts sent immediately when someone attempts to visit a blocked site, and you can specify that logs are sent automatically.

If you select the Weekly, Daily, or Hourly option and the log fills up before the specified period, the log is automatically emailed to the specified email address. After the log is sent, the log is cleared from the router's memory. If the router cannot email the log file, the log buffer might fill up. In this case, the router overwrites the log and discards its contents.

7. Click **Apply** to save your settings.

# 6 Administration

---

# 6

## Managing your network

This chapter describes the router settings for administering and maintaining your router and home network. See also [Remote Management](#) on page 85 for information about upgrading or checking the status of your router over the Internet, and [Traffic Meter](#) on page 87 for information about monitoring the volume of Internet traffic passing through your router's Internet port.

This chapter includes the following sections:

- [Router Status](#)
- [Logs](#)
- [Attached Devices](#)
- [Backup Settings](#)
- [Set Password](#)
- [Diagnostics](#)
- [Router Upgrade](#)
- [Module Upgrade](#)

## Router Status

Use the Router Status screen to check the current settings and statistics for your router. This screen shows you the current settings. If something needs to be changed, change it on the relevant screen.

➤ **To view router status and usage information:**

1. Select **ADVANCED > Administration > Router Status** to display the following screen:



The following status information is displayed:

- **Hardware Version.** The router model.
- **Firmware Version.** The version of the router firmware. It changes if you upgrade the router firmware.
- **HSDPA.**
  - **Modem Identity.**
  - **Modem SW version.**
  - **Modem driver version.**
  - **IMSI.**
  - **IMEI.**
  - **Operator.**
  - **Network mode.**
- **WAN Port.** These are the current settings that you set in the Setup Wizard or Broadband Account Settings screens.
  - **Connection Status.** This shows if the router is using a fixed IP address on the WAN. If the value is DHCP Client, the router obtains an IP address dynamically from the ISP.
  - **IP Address.** The IP address being used by the Internet (WAN) port of the router. If no address is shown or the address is 0.0.0, the router cannot connect to the Internet.



## Mobile LTE Broadband 11n Wireless Router MBR1516

- **Protocol.**
  - **IP Subnet Mask.** The subnet mask associated with the Internet IP address.
  - **IP Subnet Mask.** The IP subnet mask being used by the Internet (WAN) port of the router.
  - **Gateway to Address.**
  - **Domain Name Server.** The Domain Name Server addresses being used by the router. A Domain Name Server translates human-language URLs such as [www.netgear.com](http://www.netgear.com) into IP addresses.
  - **LAN Port.** These are the current settings, as set in the LAN IP Setup screen.
    - **MAC Address.** The Media Access Control address. This is the unique physical address being used by the Ethernet (LAN) port of the router.
    - **IP Address.** The IP address being used by the Ethernet (LAN) port of the router. The default is 192.168.0.1.
    - **DHCP Server.** Identifies whether the router's built-in DHCP server is active for the LAN-attached devices.
    - **IP Subnet Mask.** The subnet mask associated with the LAN IP address.
  - **Wireless Port.** These are the current settings, as set in the Wireless Settings screen.
    - **Name (SSID).** The SSID of the router.
    - **Region.** The location (country).
    - **Channel.** The current channel in use.
    - **Wireless AP.** Indicates if the Access Point feature of the Router is enabled or not. If not enabled, the Wireless LED on the front panel will be off.
    - **Broadcast Name.** Indicates if the Router is broadcasting its SSID.
2. Click **Show Statistics** to see router performance statistics such as the number of packets sent and number of packets received for each port.

Show Statistics

System Up Time 01:22:14

Port	Status	TxPkts	RxPkts	Collisions	Tx B/s	Rx B/s	Up Time
WAN	100MFull	922	8930	0	0	123	01:21:43.01:21:45
LAN1	Link Down	--	--	--	--	--	--
LAN2	Link Down	--	--	--	--	--	--
LAN3	Link Down	--	--	--	--	--	--
LAN4	Link Down	--	--	--	--	--	--
WLAN	145M	4004	2987	0	677	62	01:21:57

Poll Interval:  (secs)

- **System Up Time.** The time elapsed since the router was last restarted.
- **Port.** The statistics for the WAN (Internet) and LAN (Ethernet) ports. For each port, the screen displays:
  - **Status.** The link status of the port.
  - **TxPkts.** The number of packets transmitted on this port since reset or manual clear.
  - **RxPkts.** The number of packets received on this port since reset or manual clear.

## Mobile LTE Broadband 11n Wireless Router MBR1516

- **Collisions.** The number of collisions on this port since reset or manual clear.
- **Tx B/s.** The current transmission (outbound) bandwidth used on the WAN and LAN ports.
- **Rx B/s.** The current reception (inbound) bandwidth used on the WAN and LAN ports.
- **Up Time.** The time elapsed since this port acquired the link.
- **Poll Interval.** The interval at which the statistics are updated in this screen.

To change the polling frequency, enter a time in seconds in the Poll Interval field, and click **Set Interval**.

To stop the polling entirely, click **Stop**.

3. Click **Connection Status** to see information about your current connection.

Mobile Broadband Status	
Connection Status	NO SIM Card Detected
Received Signal Quality(in dbm)	0
Bytes Transmitted	112115
Bytes Received	1735113
Tx B/s	0
Rx B/s	110
System Uptime	01:21:17
Connection Duration	01:20:46

Connection Status	
IP Address	192.168.0.14
Subnet Mask	255.255.255.0
Default Gateway	192.168.0.1
DHCP Server	192.168.0.1
DNS Server	192.168.0.1
Lease Obtained	1 days,0 Hours,0 minutes.
Lease Expires	0 days,22 Hours,39 minutes.

Poll Interval:  (secs)

- Mobile Broadband Status.
  - **Connection Status.**
  - **Received Signal Quality (in dbm).**
  - **Bytes Transmitted.**
  - **Bytes Received.**
  - **Tx B/s.**
  - **Rx B/s.**
  - **System Uptime.**
  - **Connection Duration.**
- Connection Status.
  - **IP Address.** The IP address that is assigned to the router.
  - **Subnet Mask.** The subnet mask that is assigned to the router.
  - **Default Gateway.** The IP address for the default gateway that the router communicates with.

## Mobile LTE Broadband 11n Wireless Router MBR1516

- **DHCP Server.** The IP address for the Dynamic Host Configuration Protocol server that provides the TCP/IP configuration for all the computers that are connected to the router.
- **DNS Server.** The IP address of the Domain Name Service server that provides translation of network names to IP addresses.
- **Lease Obtained.** The date and time when the lease was obtained.
- **Lease Expires.** The date and time that the lease expires.

To change the polling frequency, enter a time in seconds in the Poll Interval field, and click **Set Interval**.

To stop the polling entirely, click **Stop**.

The Close Window button closes the Connection Status screen.

## Logs

The log is a detailed record of the websites you have accessed or attempted to access. If you have set up content filtering on the Block Sites screen, the Logs screen shows you when someone on your network tried to access a blocked site. If you have email notification on, you receive these logs in an e-mail message. If you do not have email notification set up, view the logs here.

Select **ADVANCED > Administration > Logs**. The Logs screen displays.

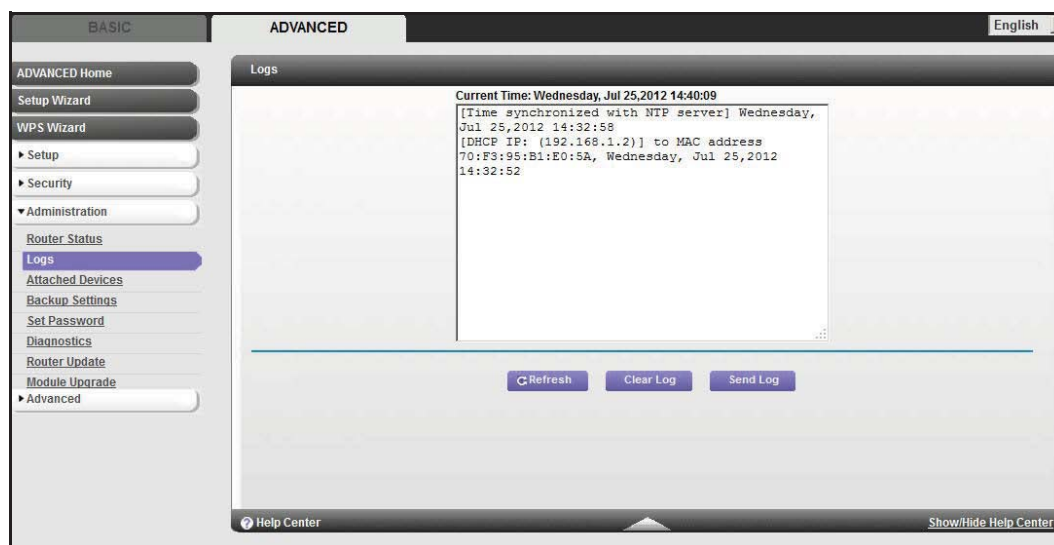

To refresh the log screen, click the **Refresh** button.

To clear the log entries, click the **Clear Log** button.

To email the log immediately, click the **Send Log** button. This feature can be very useful for testing your e-mail settings.

## Attached Devices

See *Attached Devices* on page 26.

## Backup Settings

The configuration settings of the Mobile LTE Broadband 11n Wireless Router are stored within the router in a configuration file. You can back up (save) this file to your computer, restore it, or reset it to the factory default settings.

### Back Up Settings

➤ To back up the router's configuration settings:

1. Select **ADVANCED > Administration > Backup Settings** to display the following screen:

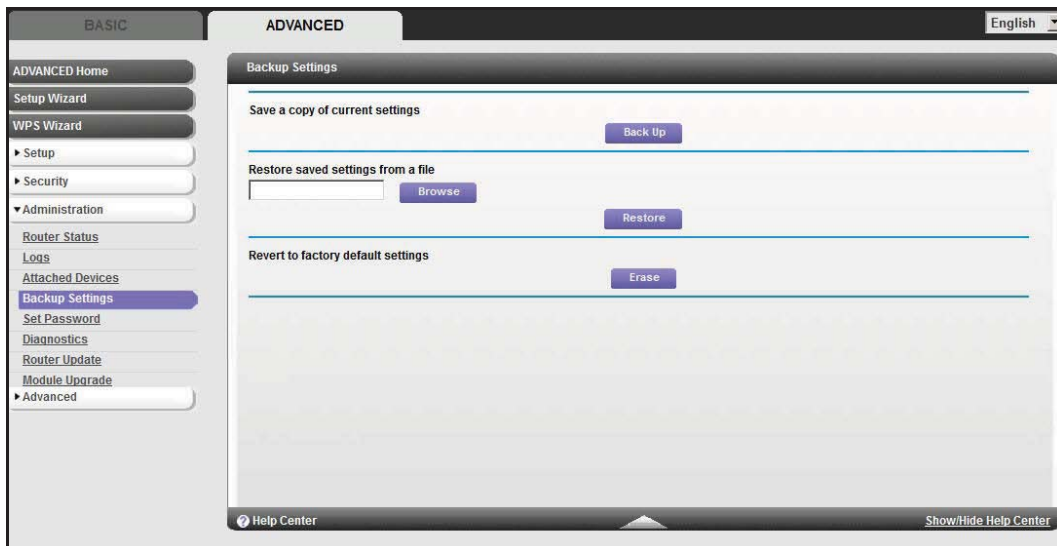

2. Click **Back Up** to save a copy of the current settings.
3. Choose a location to store the .cfg file that is on a computer on your network.

### Restore Configuration Settings

➤ To restore configuration settings that you backed up:

1. Enter the full path to the file on your network, or click the **Browse** button to find the file.
2. When you have located the .cfg file, click the **Restore** button to upload the file to the router.

Upon completion, the router reboots.



**WARNING:**

**Do not interrupt the reboot process.**

## Erase

Under some circumstances (for example, if you move the router to a different network or if you have forgotten the password), you might want to erase the configuration and restore the factory default settings.

You can either use the Restore Factory Settings button on the back of the router (see [Factory Default Settings](#) on page 99), or you can click the **Erase** button in this screen.

Erase sets the user name to admin, the password to password, and the LAN IP address to 192.168.1.1, and enables the router's DHCP.

## Set Password

This feature allows you to change the default password that is used to log in to the router with the user name **admin**.

This is not the same as changing the password for wireless access. The label on the bottom of your router shows your unique wireless network name (SSID) and password for wireless access (see [Label](#) on page 11).

➤ **To set the password for the user name admin:**

1. Select **ADVANCED > Administration > Set Password** to display the following screen:

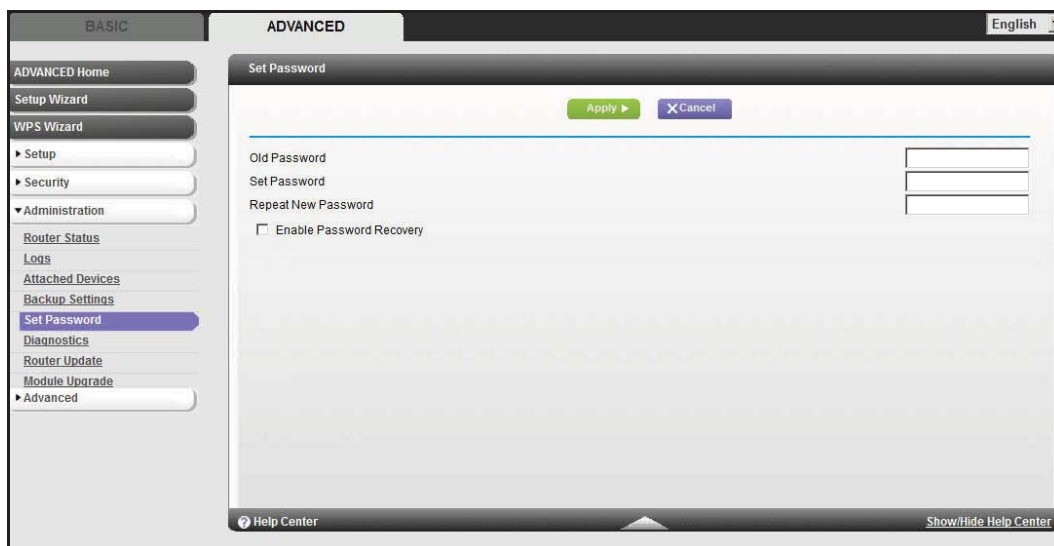

2. Type the old password, and type the new password twice in the fields on this screen.
3. If you want to be able to recover the password, select the **Enable Password Recovery** check box.

4. Click **Apply** so that your changes take effect.

## Password Recovery

NETGEAR recommends that you enable password recovery if you change the password for the router's user name of admin. Then you will have an easy way to recover the password if it is forgotten. This recovery process is supported in Internet Explorer, Firefox, and Chrome browsers, but not in the Safari browser.

- **To set up password recovery:**
  1. Select the **Enable Password Recovery** check box.
  2. Select two security questions, and provide answers to them.
  3. Click **Apply** to save your changes.

When you use your browser to access the router, the login window displays. If password recovery is enabled, when you click Cancel, the password recovery process starts. You can then enter the saved answers to the security questions to recover the password.

## Diagnostics

Use the Diagnostics screen to perform various diagnostics. For normal operation, these tests are not required.

- **To run the diagnostics:**

Select **ADVANCED > Administration > Diagnostics** to display the following screen:

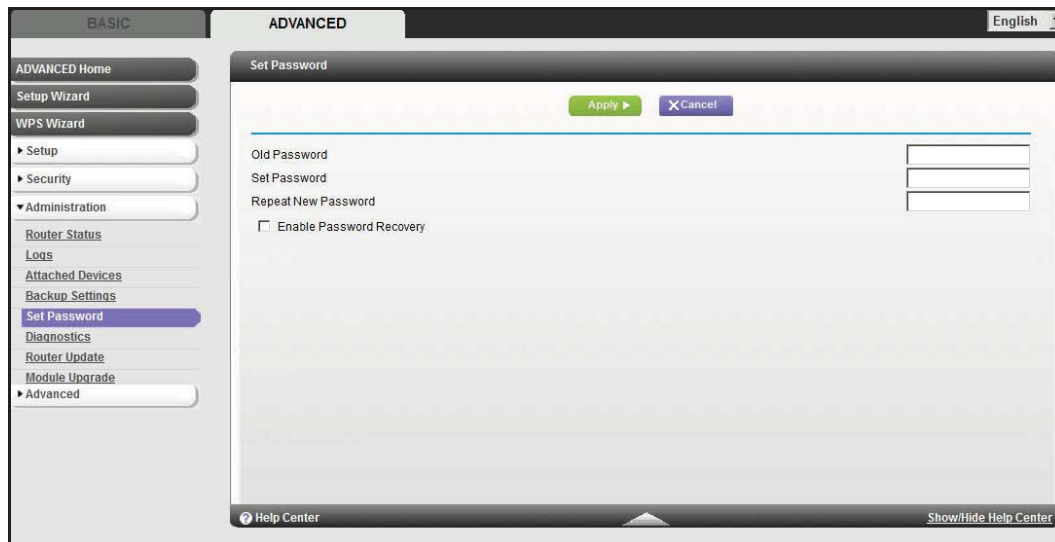

**Ping an IP address.** Use this test to send a ping packet request to the specified IP address. This procedure is often used to test a connection. If the request times out because no reply is received, this result usually means the destination is unreachable. However, some network devices can be configured not to respond to a ping.

**Perform a DNS Lookup.** A DNS (Domain Name Server) converts the Internet name (for example, www.netgear.com) to an IP address. If you need the IP address of a Web, FTP, Mail or other Server on the Internet, you can do a DNS lookup to find the IP address.

**Display the Routing Table.** This operation displays the internal routing table. This information is used by technical support and other staff who understand routing tables.

**Reboot the Router.** Use this button to perform a remote reboot (restart). You can use this if the Router seems to have become unstable or is not operating normally.

---

**Note:** Rebooting will break any existing connections either to the router (such as this one) or through the router (for example, LAN users accessing the Internet). However, connections to the Internet automatically re-established when possible.

---

## Router Upgrade

The router firmware (routing software) is stored in flash memory. You can update the firmware from the Administration menu on the Advanced tab. You might see a message at the top of the NETGEAR genie screens when new firmware is available for your product.

You can use the Check button on the Router Update screen to check and update to the latest firmware for your product if new firmware is available.

➤ **To check for new firmware and update your router:**

1. Select **ADVANCED > Administration > Router Update** to display the following screen:

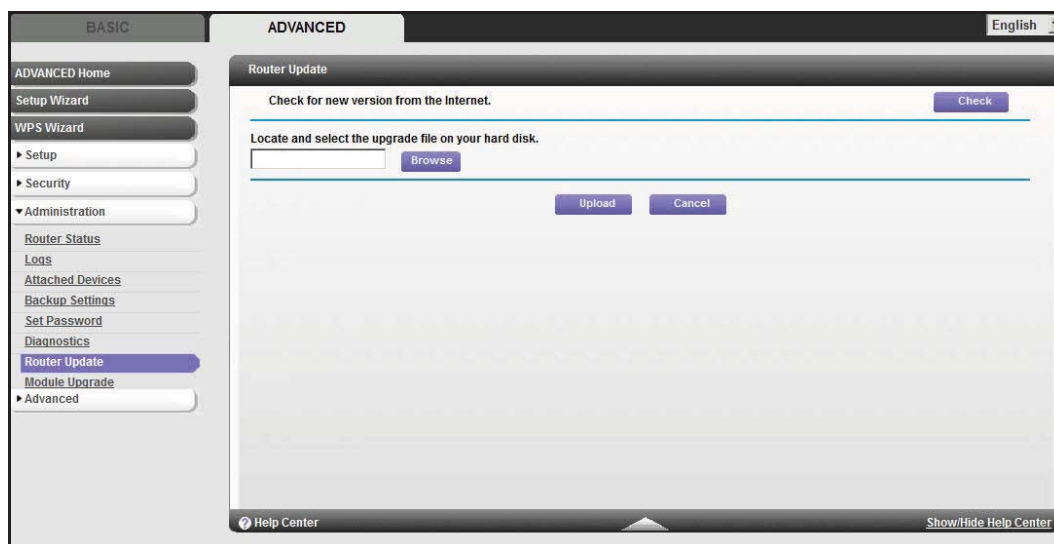

2. Click **Check**.

The router finds new firmware information if any is available.

3. Click **Yes** to update and locate the firmware you downloaded (the file ends in .img).



**WARNING:**

**When uploading firmware to the router, *do not* interrupt the web browser by closing the window, clicking a link, or loading a new page. If the browser is interrupted, it could corrupt the firmware.**

When the upload is complete, your router restarts. The upgrade process typically takes about 1 minute. Read the new firmware release notes to determine whether or not you need to reconfigure the router after upgrading.

## Module Upgrade

The module firmware (broadband mobile software) is stored in flash memory. You can upgrade the firmware from the Administration menu on the Advanced tab. You might see a message at the top of the NETGEAR genie screens when new firmware is available for your product.

You can use the Check button on the Module Upgrade screen to check and update to the latest firmware for your product if new firmware is available.

➤ **To check for new firmware and update your router:**

1. Select **ADVANCED > Administration > Module Upgrade** to display the following screen:

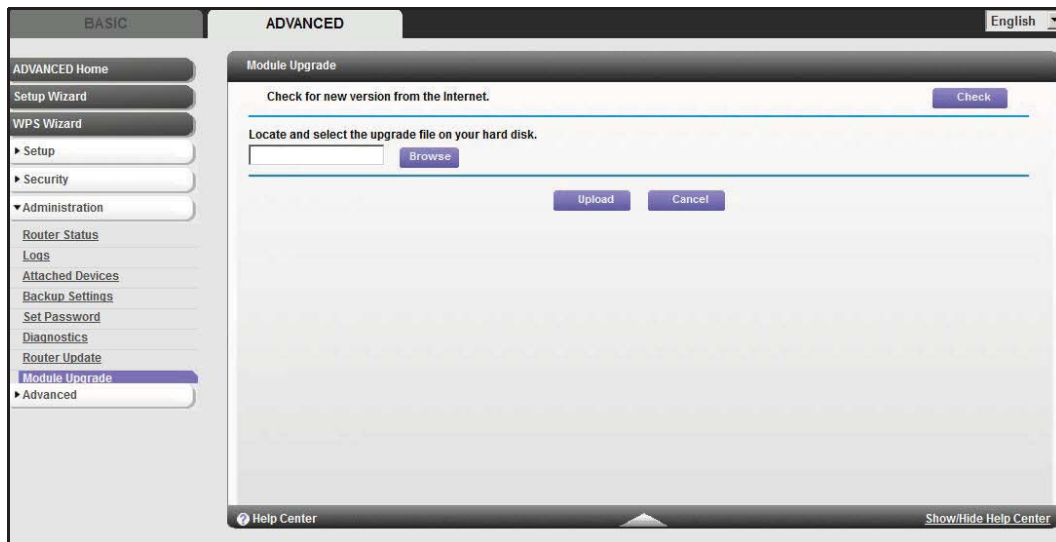

2. Click **Check**.  
The router finds new firmware information if any is available.
3. Click **Yes** to update and locate the firmware you downloaded (the file ends in .img).





**WARNING:**

When uploading firmware to the router, *do not* interrupt the web browser by closing the window, clicking a link, or loading a new page. If the browser is interrupted, it could corrupt the firmware.

When the upload is complete, your router restarts. The upgrade process typically takes about 1 minute. Read the new firmware release notes to determine whether or not you need to reconfigure the router after upgrading.

# Advanced Settings

---

# 7

This chapter describes the advanced features of your router. The information is for users with a solid understanding of networking concepts who want to set the router up for unique situations such as when remote access from the Internet by IP or domain name is needed.

This chapter includes the following sections:

- *SIM Settings*
- *SMS Messages*
- *Wireless Settings*
- *Wireless Repeating*
- *Port Forwarding and Port Triggering*
- *Dynamic DNS*
- *Static Routes*
- *Remote Management*
- *Universal Plug and Play*
- *Traffic Meter*

## SIM Settings

Your ISP provides you with a SIM card so that you can access mobile broadband. Use this screen to change your SIM card settings.

➤ **To change your SIM card settings:**

1. Select **Advanced > Advanced Setup > SIM Settings** to display the following screen:

2. Change your SIM card settings as necessary:
  - **Enabling or Disabling the PIN Code.** Enable or disable the use of the SIM card PIN code.
  - **Changing the PIN Code.** The PIN code prevents the use of the SIM card in an unauthorized device. Also, change the PIN code regularly for security reasons.
3. Click **Apply** so that your changes take effect.

## SMS Messages

See [SMS Message](#) on page 30.

## Wireless Settings

---

**Note:** The wireless router is already configured with the optimum settings. Do not alter these settings unless directed by NETGEAR support. Incorrect settings disable the wireless router.

---

Select **Advanced > Advanced Setup > Wireless Settings** to display the following screen:



The following settings are available in this screen:

**Advanced Wireless Settings.** Do not change these settings unless directed to do so by NETGEAR support.

- **Enable Wireless Router Radio.** You can completely turn off the wireless portion of the wireless router by clearing this check box. Select this check box again to enable the wireless portion of the router. When the wireless radio is disabled, other members of your household can use the router by connecting their computers to the router with an Ethernet cable.

---

**Note:** The Fragmentation Length, CTS/RTS Threshold, and Preamble Mode options are reserved for wireless testing and advanced configuration only. Do not change these settings.

---

- **Enable SSID Broadcast.** This setting enables broadcasting of the SSID.
- **Fragmentation Threshold, CTS/RTS Threshold, and Preamble Mode.** These settings are reserved for wireless testing and advanced configuration only. Do not change these settings.
- **Wireless Signal Strength.** This setting allows adjusting the power of Wi-Fi from 1% (minimum) to 100% (maximum). Enter an integer ranging from 1 to 100 (default) in

this field. Lowering the Wi-Fi power limits the range of Wi-Fi and reduces the Wi-Fi radiation.

**WPS Settings.** You can add WPS devices to your network.

- **Router's PIN.** This is the PIN number you use on a registrar (e.g., from Network Explorer on a Vista Windows PC) to configure the router's wireless settings through WPS. You can also find the PIN on the router's product label.
- **Disable Router's PIN.** You can configure the router's wireless settings or add a wireless client through WPS using the router's PIN only when the PIN is enabled. The router's PIN can be disabled temporarily when the router detects suspicious attempts to break into the router's wireless settings by using the router's PIN through WPS. You can manually enable this function by clearing the check box and clicking the Apply button.
- **Keep Existing Wireless Settings.** This setting shows whether the router is in the WPS configured state. If this option is not selected, adding a new wireless client changes the router's wireless settings to an automatically generated random SSID and security key. In addition, when this option is selected, some external registrars (e.g., Network Explorer on Vista Windows) might not see the router.

Configuring the basic wireless settings from the router's management GUI selects this option automatically.

**Wireless Card Access List.** By default, any wireless computer that is configured with the correct SSID is allowed access to your wireless network. For increased security, restrict access to the wireless network to allow only specific computers based on their MAC addresses. Click the **Set Up Access List** button display the Wireless Card Access List screen. On this screen you can restrict access to your network to specific devices based on their MAC address.

Click **Add** to add wireless devices to your network based on their MAC address.

Click **Apply** to have your changes take effect.

## Wireless Repeating

You can set the Mobile LTE Broadband 11n Wireless Router up to be used as a wireless access point (AP). Doing this enables the router to act as a wireless repeater. A wireless repeater connects to another wireless router as a client where the network to which it connects becomes the ISP service.

Wireless repeating is a type of Wireless Distribution System (WDS). A WDS allows a wireless network to be expanded through multiple access points instead of using a wired backbone to link them. The following figure shows a wireless repeating scenario.

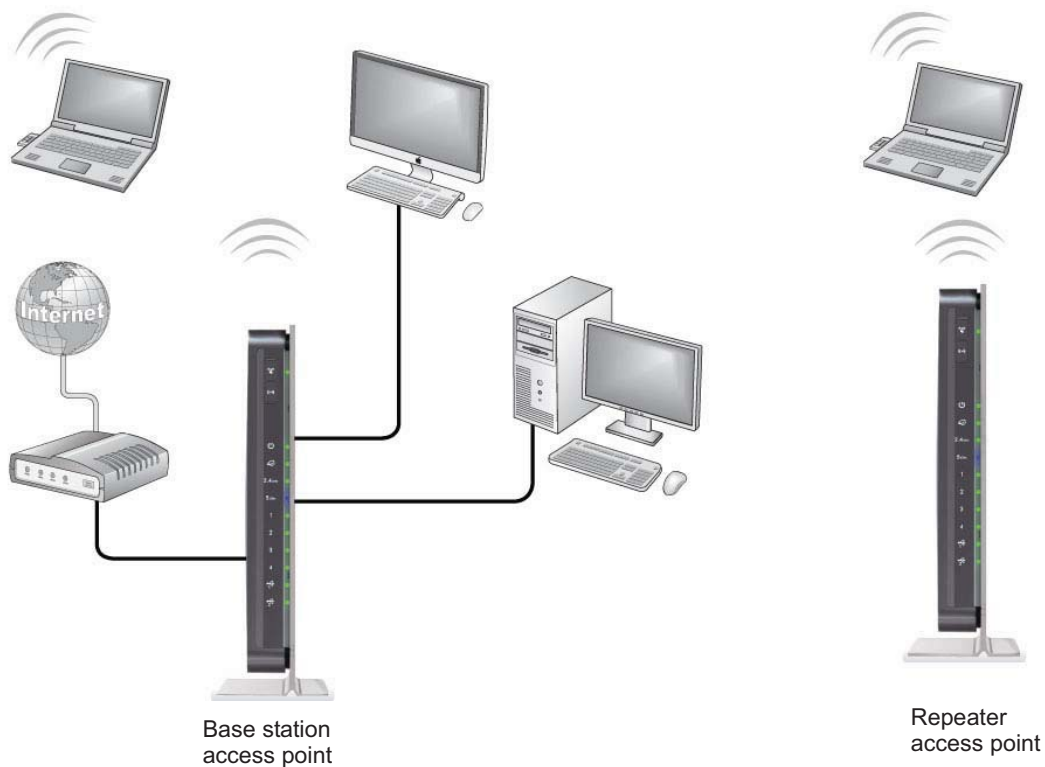

Figure 6. Wireless repeating scenario

---

**Note:** If you use the wireless repeating function, you need to select either **WEP** or **None** as a security option in the Wireless Settings screen. The WEP option displays only if you select the wireless mode **Up to 54 Mbps** in the Wireless Settings screen.

---

**Wireless Base Station.** The router acts as the parent access point, bridging traffic to and from the child repeater access point, as well as handling wireless and wired local computers. To configure this mode, you have to know the MAC addresses of the child repeater access point.

**Wireless Repeater.** The router sends all traffic from its local wireless or wired computers to a remote access point. To configure this mode, you have to know the MAC address of the remote parent access point.

The MBR1516 router is always in dual band concurrent mode, unless you turn off one radio. Be aware that if you enable the wireless repeater in either radio band, the wireless base station or wireless repeater cannot be enabled in the other radio band. However, if you enable the wireless base station in either radio band and use the other radio band as a wireless router or wireless base station, dual band concurrent mode is not affected.

For you to set up a wireless network with WDS, the following conditions have to be met for both access points:

- Both access points have to use the same SSID, wireless channel, and encryption mode.
- Both access points have to be on the same LAN IP subnet. That is, all the access point LAN IP addresses are in the same network.
- All LAN devices (wired and wireless computers) have to be configured to operate in the same LAN network address range as the access points.

## Wireless Repeating Function

Select **Advanced > Advanced Setup > Wireless Repeating** to view or change wireless repeater settings for the router.

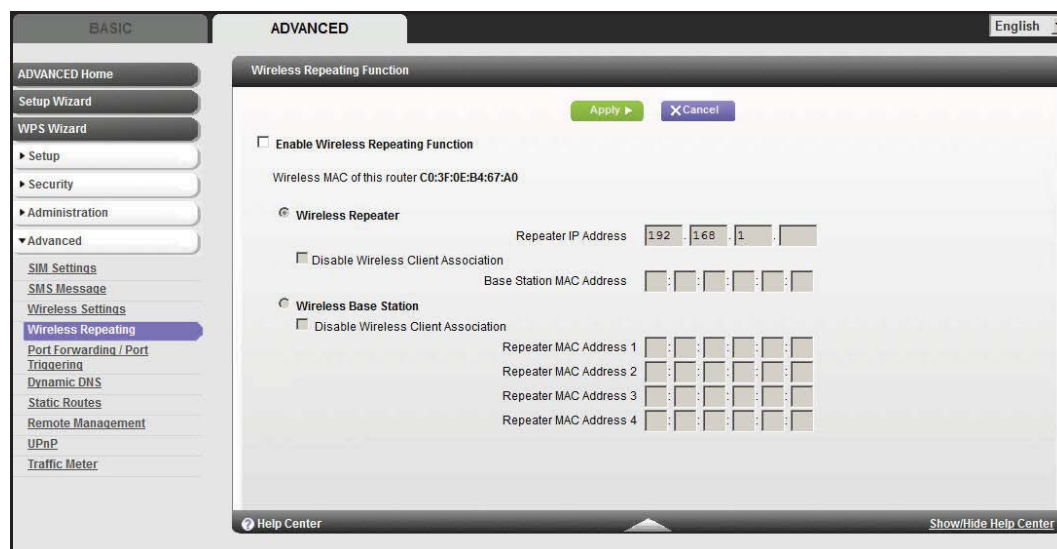

- **Enable Wireless Repeating Function.** Select the check box for the 2.4 GHz or 5 GHz network to use the wireless repeating function.
- **Wireless MAC of this router.** This field displays the MAC address for your router for your reference. You will need to enter this MAC address in the corresponding Wireless Repeating Function screen of the other access point you are using.
- **Wireless Repeater.** If your router is the repeater, select this check box.

**Repeater IP Address.** If your router is the repeater, enter the IP address of the other access point.

**Disable Wireless Client Association.** If your router is the repeater, selecting this check box means that wireless clients cannot associate with it. Only LAN client associations are allowed.

- If you are setting up a point-to-point bridge, select this check box.
- If you want all client traffic to go through the other access point (repeater with wireless client association), leave this check box cleared.

**Base Station MAC Address.** If your router is the repeater, enter the MAC address for the access point that is the base station.

- **Wireless Base Station.** If your router is the base station, select this check box.

**Disable Wireless Client Association.** If your router is the base station, selecting this check box means that wireless clients cannot associate with it. Only LAN client associations are allowed.

**Repeater MAC Address (1 through 4).** If your router is the base station, it can act as the “parent” of up to 4 other access points. Enter the MAC addresses of the other access points in these fields.

## Set Up the Base Station

The wireless repeating function works only in hub and spoke mode. The units cannot be daisy-chained. You have to know the wireless settings for both units. You have to know the MAC address of the remote unit. First, set up the base station, and then set up the repeater.

### ➤ To set up the base station:

1. Set up both units with exactly the same wireless settings (SSID, mode, channel, and security). Note that the wireless security option has to be set to None or WEP.
2. Select **Advanced > Advanced Setup > Wireless Repeating Function** to display the Wireless Repeating Function screen.
3. In the Wireless Repeating Function screen (depending on the frequency you want to use), select the **Enable Wireless Repeating Function** check box and select the **Wireless Base Station** radio button.
4. Enter the MAC address for one or more repeater units.
5. Click **Apply** to save your changes.

## Set Up a Repeater Unit

Use a wired Ethernet connection to set up the repeater unit to avoid conflicts with the wireless connection to the base station.



---

**Note:** If you are using the MBR1516 base station with a non-NETGEAR router as the repeater, you might need to change additional configuration settings. In particular, you should disable the DHCP server function on the wireless repeater AP.

---

➤ **To configure the router as a repeater unit:**

1. Log in to the router that will be the repeater. Select **BASIC > Wireless Settings** and verify that the wireless settings match the base unit exactly. The wireless security option has to be set to **WEP** or **None**.
2. Select **Advanced > Wireless Repeating Function**, and select the **Enable Wireless Repeating Function check box** and the **Wireless Repeater** radio button.
3. Fill in the Repeater IP Address field. This IP address has to be in the same subnet as the base station, but different from the LAN IP address of the base station.
4. Click **Apply** to save your changes.
5. Verify connectivity across the LANs.

A computer on any wireless or wired LAN segment of the router should be able to connect to the Internet or share files and printers with any other wireless or wired computer or server connected to the other access point.

## Port Forwarding and Port Triggering

By default, the router blocks inbound traffic from the Internet to your computers except replies to your outbound traffic. You might need to create exceptions to this rule for these purposes:

- To allow remote computers on the Internet to access a server on your local network.
- To allow certain applications and games to work correctly when their replies are not recognized by your router.

Your router provides two features for creating these exceptions: port forwarding and port triggering. The next sections provide background information to help you understand how port forwarding and port triggering work, and the differences between the two.

### Remote Computer Access Basics

When a computer on your network needs to access a computer on the Internet, your computer sends your router a message containing the source and destination address and process information. Before forwarding your message to the remote computer, your router has to modify the source information and create and track the communication session so that replies can be routed back to your computer.

Here is an example of normal outbound traffic and the resulting inbound responses:

1. You open a browser, and your operating system assigns port number 5678 to this browser session.

2. You type `http://www.example.com` into the URL field, and your computer creates a web page request message with the following address and port information. The request message is sent to your router.

**Source address.** Your computer's IP address.

**Source port number.** 5678, which is the browser session.

**Destination address.** The IP address of `www.example.com`, which your computer finds by asking a DNS server.

**Destination port number.** 80, which is the standard port number for a web server process.

3. Your router creates an entry in its internal session table describing this communication session between your computer and the web server at `www.example.com`. Before sending the web page request message to `www.example.com`, your router stores the original information and then modifies the source information in the request message, performing Network Address Translation (NAT):
  - The source address is replaced with your router's public IP address. This is necessary because your computer uses a private IP address that is not globally unique and cannot be used on the Internet.
  - The source port number is changed to a number chosen by the router, such as 33333. This is necessary because two computers could independently be using the same session number.

Your router then sends this request message through the Internet to the web server at `www.example.com`.

4. The web server at `www.example.com` composes a return message with the requested web page data. The return message contains the following address and port information. The web server then sends this reply message to your router.

**Source address.** The IP address of `www.example.com`.

**Source port number.** 80, which is the standard port number for a web server process.

**Destination address.** The public IP address of your router.

**Destination port number.** 33333.

5. Upon receiving the incoming message, your router checks its session table to determine whether there is an active session for port number 33333. Finding an active session, the router then modifies the message to restore the original address information replaced by NAT. Your router sends this reply message to your computer, which displays the web page from `www.example.com`. The message now contains the following address and port information.

**Source address.** The IP address of `www.example.com`.

**Source port number.** 80, which is the standard port number for a web server process.

**Destination address.** Your computer's IP address.

**Destination port number.** 5678, which is the browser session that made the initial request.

6. When you finish your browser session, your router eventually detects a period of inactivity in the communications. Your router then removes the session information from its session table, and incoming traffic is no longer accepted on port number 33333.

## Port Triggering to Open Incoming Ports

In the preceding example, requests are sent to a remote computer by your router from a particular service port number, and replies from the remote computer to your router are directed to that port number. If the remote server sends a reply back to a different port number, your router does not recognize it and discards it. However, some application servers (such as FTP and IRC servers) send replies back to multiple port numbers. Using the port triggering function of your router, you can tell the router to open additional incoming ports when a particular outgoing port originates a session.

An example is Internet Relay Chat (IRC). Your computer connects to an IRC server at destination port 6667. The IRC server not only responds to your originating source port, but also sends an “identify” message to your computer on port 113. Using port triggering, you can tell the router, “When you initiate a session with destination port 6667, you have to also allow incoming traffic on port 113 to reach the originating computer.” Using steps similar to the preceding example, the following sequence shows the effects of the port triggering rule you have defined:

1. You open an IRC client program to start a chat session on your computer.
2. Your IRC client composes a request message to an IRC server using a destination port number of 6667, the standard port number for an IRC server process. Your computer then sends this request message to your router.
3. Your router creates an entry in its internal session table describing this communication session between your computer and the IRC server. Your router stores the original information, performs Network Address Translation (NAT) on the source address and port, and sends this request message through the Internet to the IRC server.
4. Noting your port triggering rule and having observed the destination port number of 6667, your router creates an additional session entry to send any incoming port 113 traffic to your computer.
5. The IRC server sends a return message to your router using the NAT-assigned source port (as in the previous example, say port 33333) as the destination port. The IRC server also sends an “identify” message to your router with destination port 113.
6. Upon receiving the incoming message to destination port 33333, your router checks its session table to determine whether there is an active session for port number 33333. Finding an active session, the router restores the original address information replaced by NAT and sends this reply message to your computer.
7. Upon receiving the incoming message to destination port 113, your router checks its session table and learns that there is an active session for port 113, associated with your computer. The router replaces the message’s destination IP address with your computer’s IP address and forwards the message to your computer.
8. When you finish your chat session, your router eventually senses a period of inactivity in the communications. The router then removes the session information from its session table, and incoming traffic is no longer accepted on port numbers 33333 or 113.

To configure port triggering, you need to know which inbound ports the application needs. Also, you need to know the number of the outbound port that will trigger the opening of the inbound ports. You can usually determine this information by contacting the publisher of the application or user groups or newsgroups.

---

**Note:** Only one computer at a time can use the triggered application.

---

## Port Forwarding to Permit External Host Communications

In both of the preceding examples, your computer initiates an application session with a server computer on the Internet. However, you might need to allow a client computer on the Internet to initiate a connection to a server computer on your network. Normally, your router ignores any inbound traffic that is not a response to your own outbound traffic. You can configure exceptions to this default rule by using the port forwarding feature.

A typical application of port forwarding can be shown by reversing the client-server relationship from the previous web server example. In this case, a remote computer's browser needs to access a web server running on a computer in your local network. Using port forwarding, you can tell the router, "When you receive incoming traffic on port 80 (the standard port number for a web server process), forward it to the local computer at 192.168.1.123." The following sequence shows the effects of the port forwarding rule you have defined:

1. The user of a remote computer opens a browser and requests a web page from [www.example.com](http://www.example.com), which resolves to the public IP address of your router. The remote computer composes a web page request message with the following destination information:

**Destination address.** The IP address of [www.example.com](http://www.example.com), which is the address of your router.

**Destination port number.** 80, which is the standard port number for a web server process.

The remote computer then sends this request message through the Internet to your router.

2. Your router receives the request message and looks in its rules table for any rules covering the disposition of incoming port 80 traffic. Your port forwarding rule specifies that incoming port 80 traffic should be forwarded to local IP address 192.168.1.123. Therefore, your router modifies the destination information in the request message:

The destination address is replaced with 192.168.1.123.

Your router then sends this request message to your local network.

3. Your web server at 192.168.1.123 receives the request and composes a return message with the requested web page data. Your web server then sends this reply message to your router.

4. Your router performs Network Address Translation (NAT) on the source IP address, and sends this request message through the Internet to the remote computer, which displays the web page from www.example.com.

To configure port forwarding, you need to know which inbound ports the application needs. You usually can determine this information by contacting the publisher of the application or the relevant user groups and newsgroups.

## How Port Forwarding Differs from Port Triggering

The following points summarize the differences between port forwarding and port triggering:

- Port triggering can be used by any computer on your network, although only one computer can use it at a time.
- Port forwarding is configured for a single computer on your network.
- Port triggering does require that you know the computer's IP address in advance. The IP address is captured automatically.
- Port forwarding requires that you specify the computer's IP address during configuration, and the IP address can never change.
- Port triggering requires specific outbound traffic to open the inbound ports, and the triggered ports are closed after a period of no activity.
- Port forwarding is always active and does not need to be triggered.

## Set Up Port Forwarding to Local Servers

Using the port forwarding feature, you can allow certain types of incoming traffic to reach servers on your local network. For example, you might want to make a local web server, FTP server, or game server visible and available to the Internet.

Use the Port Forwarding screen to configure the router to forward specific incoming protocols to computers on your local network. In addition to servers for specific applications, you can also specify a default DMZ server to which all other incoming protocols are forwarded.

Before starting, you need to determine which type of service, application, or game you want to provide, and the local IP address of the computer that will provide the service. The server computer has to always have the same IP address.

### ➤ To set up port forwarding:

**Tip:** To ensure that your server computer always has the same IP address, use the reserved IP address feature of your Mobile LTE Broadband 11n Wireless Router.

1. Select **Advanced Setup > Port Forwarding/Port Triggering** to display the following screen:

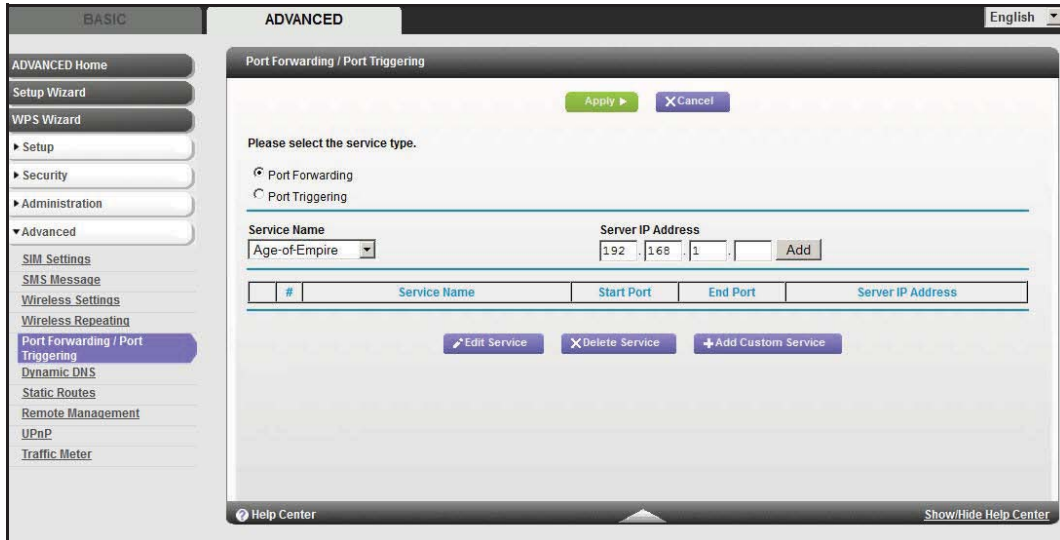

Port Forwarding is selected as the service type.

2. From the Service Name list, select the service or game that you will host on your network. If the service does not appear in the list, see [Add a Custom Service](#) on page 78.
3. In the corresponding Server IP Address field, enter the last digit of the IP address of your local computer that will provide this service.
4. Click **Add**. The service appears in the list in the screen.

### Add a Custom Service

To define a service, game, or application that does not appear in the Service Name list, you have to first determine which port number or range of numbers is used by the application. You can usually determine this information by contacting the publisher of the application or user groups or newsgroups.

➤ **To add a custom service:**

1. Select **Advanced > Advanced Setup > Port Forwarding/Port Triggering**.
2. Select **Port Forwarding** as the service type.
3. Click the **Add Custom Service** button to display the following screen:

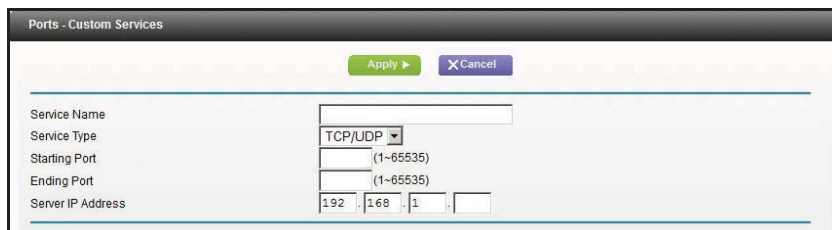

4. In the Service Name field, enter a descriptive name.

5. In the Protocol list, select the protocol. If you are unsure, select **TCP/UDP**.
6. In the Starting Port field, enter the beginning port number.
  - If the application uses a single port, enter the same port number in the Ending Port field.
  - If the application uses a range of ports, enter the ending port number of the range in the Ending Port field.
7. In the Server IP Address field, enter the IP address of your local computer that will provide this service.
8. Click **Apply**. The service appears in the list in the Port Forwarding/Port Triggering screen.

### *Editing or Deleting a Port Forwarding Entry*

➤ **To edit or delete a port forwarding entry:**

1. In the table, select the radio button next to the service name.
2. Click **Edit Service** or **Delete Service**.

### *Application Example: Making a Local Web Server Public*

If you host a web server on your local network, you can use port forwarding to allow web requests from anyone on the Internet to reach your web server.

➤ **To make a local web server public:**

1. Assign your web server either a fixed IP address or a dynamic IP address using DHCP address reservation. In this example, your router will always give your web server an IP address of 192.168.1.33.
2. In the Port Forwarding screen, configure the router to forward the HTTP service to the local address of your web server at **192.168.1.33**. HTTP (port 80) is the standard protocol for web servers.
3. (Optional) Register a host name with a Dynamic DNS service, and configure your router to use the name as described in *Dynamic DNS* on page 81. To access your web server from the Internet, a remote user has to know the IP address that has been assigned by your ISP. However, if you use a Dynamic DNS service, the remote user can reach your server by a user-friendly Internet name, such as mynetgear.dyndns.org.

## **Set Up Port Triggering**

Port triggering is a dynamic extension of port forwarding that is useful in these cases:

- More than one local computer needs port forwarding for the same application (but not simultaneously).
- An application needs to open incoming ports that are different from the outgoing port.

When port triggering is enabled, the router monitors outbound traffic looking for a specified outbound “trigger” port. When the router detects outbound traffic on that port, it remembers the IP address of the local computer that sent the data. The router then temporarily opens the

specified incoming port or ports, and forwards incoming traffic on the triggered ports to the triggering computer.

While port forwarding creates a static mapping of a port number or range to a single local computer, port triggering can dynamically open ports to any computer that needs them and can close the ports when they are no longer needed.

---

**Note:** If you use applications such as multiplayer gaming, peer-to-peer connections, real-time communications such as instant messaging, or remote assistance (a feature in Windows XP), you should also enable Universal Plug and Play (UPnP) according to the instructions in [Universal Plug and Play](#) on page 86.

---

To set up port triggering, you need to know which inbound ports the application needs. Also, you need to know the number of the outbound port that will trigger the opening of the inbound ports. You can usually determine this information by contacting the publisher of the application or user groups or newsgroups.

➤ **To set up port triggering:**

1. Select **Advanced > Advanced Setup > Port Forwarding/Port Triggering**.
2. Select the **Port Triggering** radio button to display the port triggering information.

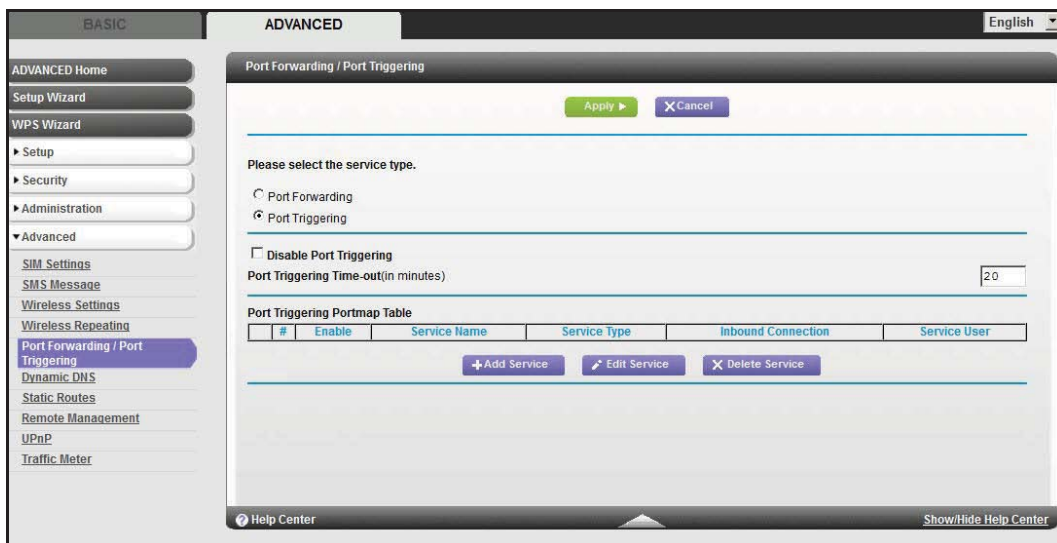

3. Clear the **Disable Port Triggering** check box if it is selected.

**Note:** If the *Disable Port Triggering* check box is selected after you configure port triggering, port triggering is disabled. However, any port triggering configuration information you added to the router is retained even though it is not used.



4. In the Port Triggering Timeout field, enter a value up to 9999 minutes.
5. This value controls the inactivity timer for the designated inbound ports. The inbound ports close when the inactivity time expires. This is required because the router cannot be sure when the application has terminated.
6. Click **Add Service** to display the following screen:

7. In the Service Name field, type a descriptive service name.
8. In the Service User list, select **Any** (the default) to allow this service to be used by any computer on the Internet. Otherwise, select **Single address**, and enter the IP address of one computer to restrict the service to a particular computer.
9. Select the service type, either **TCP** or **UDP** or both (**TCP/UDP**). If you are not sure, select TCP/UDP.
10. In the Triggering Port field, enter the number of the outbound traffic port that will cause the inbound ports to be opened.
11. Enter the inbound connection port information in the Connection Type, Starting Port, and Ending Port fields.
12. Click **Apply**. The service appears in the Port Triggering Portmap table.

## Dynamic DNS

If your Internet service provider (ISP) gave you a permanently assigned IP address, you can register a domain name and have that name linked with your IP address by public Domain Name Servers (DNS). However, if your Internet account uses a dynamically assigned IP address, you do not know in advance what your IP address will be, and the address can change frequently. In this case, you can use a commercial Dynamic DNS service. This type of service lets you register your domain to their IP address and forwards traffic directed at your domain to your frequently changing IP address.

If your ISP assigns a private WAN IP address (such as 192.168.x.x or 10.x.x.x), the Dynamic DNS service will not work because private addresses are not routed on the Internet.

Your router contains a client that can connect to the Dynamic DNS service provided by DynDNS.org. First visit their website at <http://www.dyndns.org> and obtain an account and host name that you configure in the router. Then, whenever your ISP-assigned IP address changes, your router automatically contacts the Dynamic DNS service provider, logs in to your account, and registers your new IP address. If your host name is hostname, for example, you can reach your router at <http://hostname.dyndns.org>.

On the Advanced tab, select **Advanced Setup > Dynamic DNS** to display the following screen:

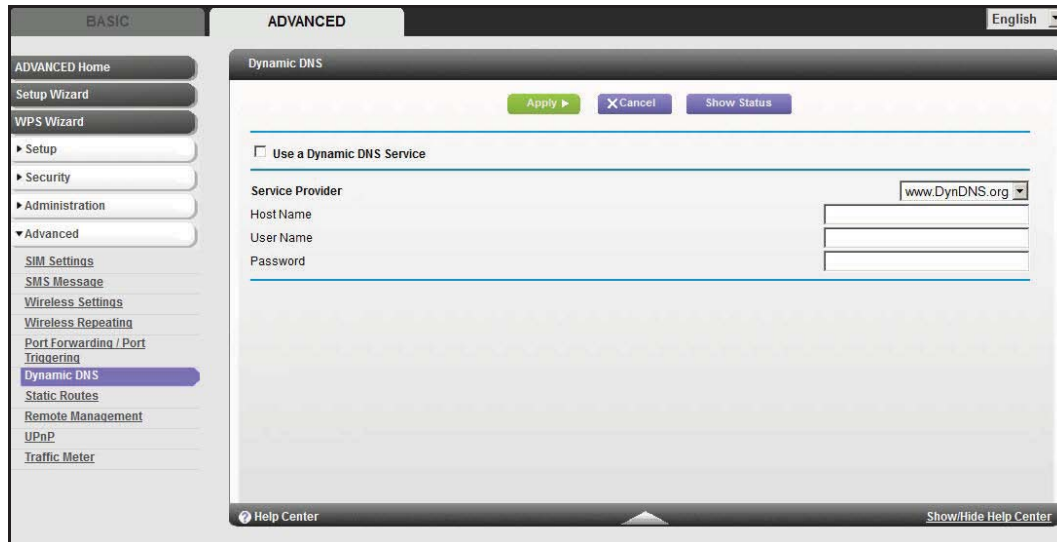

Figure 7. Forward traffic to a changing IP address

➤ **To set up Dynamic DNS:**

1. Register for an account with one of the Dynamic DNS service providers whose names appear in the Service Provider list. For example, for DynDNS.org, select [www.dyndns.org](http://www.dyndns.org).
2. Select the **Use a Dynamic DNS Service** check box.
3. Select the name of your Dynamic DNS service provider.
4. Type the host name (or domain name) that your Dynamic DNS service provider gave you.
5. Type the user name for your Dynamic DNS account. This is the name that you use to log in to your account, not your host name.
6. Type the password (or key) for your Dynamic DNS account.
7. If your Dynamic DNS provider allows the use of wildcards in resolving your URL, you can select the **Use Wildcards** check box to activate this feature.

For example, the wildcard feature causes *\*.yourhost.dyndns.org* to be aliased to the same IP address as yourhost.dyndns.org.

8. Click **Apply** to save your configuration.

## Static Routes

Static routes provide additional routing information to your router. Under usual circumstances, the router has adequate routing information after it has been configured for Internet access, and you do not need to configure additional static routes. You have to configure static routes only for unusual cases such as multiple routers or multiple IP subnets located on your network.

As an example of when a static route is needed, consider the following case:

- Your primary Internet access is through a cable modem to an ISP.
- You have an ISDN router on your home network for connecting to the company where you are employed. This router's address on your LAN is 192.168.1.100.
- Your company's network address is 134.177.0.0.

When you first configured your router, two implicit static routes were created. A default route was created with your ISP as the gateway, and a second static route was created to your local network for all 192.168.1.x addresses. With this configuration, if you attempt to access a device on the 134.177.0.0 network, your router forwards your request to the ISP. The ISP forwards your request to the company where you are employed, and the request is likely to be denied by the company's firewall.

In this case you have to define a static route, telling your router that 134.177.0.0 should be accessed through the ISDN router at 192.168.1.100. In this example:

- The Destination IP Address and IP Subnet Mask fields specify that this static route applies to all 134.177.x.x addresses.
- The Gateway IP Address field specifies that all traffic for these addresses should be forwarded to the ISDN router at 192.168.1.100.
- A metric value of 1 will work since the ISDN router is on the LAN.
- Private is selected only as a precautionary security measure in case RIP is activated.

➤ **To set up a static route:**

1. Select **Advanced > Advanced Setup > Static Routes** to display the following screen:

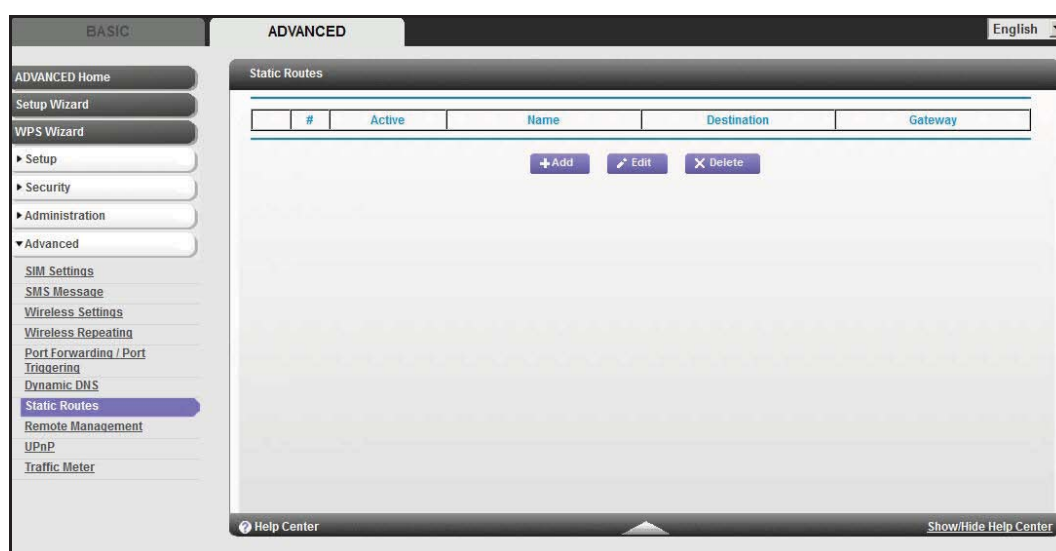

2. Click **Add** to display the following screen:

3. In the Route Name field, type a name for this static route (for identification purposes only.)
4. Select the **Private** check box if you want to limit access to the LAN only. If Private is selected, the static route is not reported in RIP.
5. Select the **Active** check box to make this route effective.
6. Type the destination IP address of the final destination.
7. Type the IP subnet mask for this destination. If the destination is a single host, type **255.255.255.255**.
8. Type the gateway IP address, which has to be a router on the same LAN segment as the Mobile LTE Broadband 11n Wireless Router.
9. Type a number between 1 and 15 as the metric value.  
This value represents the number of routers between your network and the destination. Usually, a setting of 2 or 3 works, but if this is a direct connection, set it to 1.
10. Click **Apply** to add the static route.

## Remote Management

The remote management feature lets you upgrade or check the status of your Mobile LTE Broadband 11n Wireless Router over the Internet.

➤ **To set up remote management:**

1. Select **Advanced > Advanced Setup > Remote Management**.

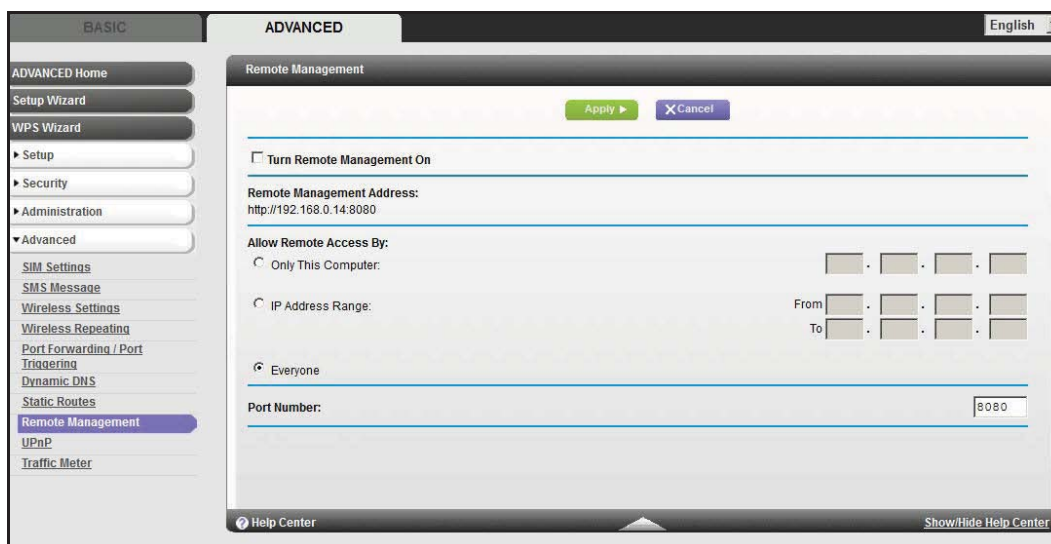

**Note:** Be sure to change the router's default login password to a very secure password. The ideal password should contain no dictionary words from any language and contain uppercase and lowercase letters, numbers, and symbols. It can be up to 30 characters.

2. Select the **Turn Remote Management On** check box.
3. Under Allow Remote Access By, specify the external IP addresses to be allowed to access the router's remote management.

---

**Note:** For enhanced security, restrict access to as few external IP addresses as practical.

---

- To allow access from a single IP address on the Internet, select **Only This Computer**. Enter the IP address that will be allowed access.
  - To allow access from a range of IP addresses on the Internet, select **IP Address Range**. Enter a beginning and ending IP address to define the allowed range.
  - To allow access from any IP address on the Internet, select **Everyone**.
4. Specify the port number for accessing the management interface.

Normal web browser access uses the standard HTTP service port 80. For greater security, enter a custom port number for the remote web management interface. Choose a number between 1024 and 65535, but do not use the number of any common service port. The default is 8080, which is a common alternate for HTTP.

5. Click **Apply** to have your changes take effect.
6. When accessing your router from the Internet, type your router's WAN IP address into your browser's address or location field followed by a colon (:) and the custom port number. For example, if your external address is 134.177.0.123 and you use port number 8080, enter **http://134.177.0.123:8080** in your browser.

## Universal Plug and Play

Universal Plug and Play (UPnP) helps devices, such as Internet appliances and computers, to access the network and connect to other devices as needed. UPnP devices can automatically discover the services from other registered UPnP devices on the network.

---

**Note:** If you use applications such as multiplayer gaming, peer-to-peer connections, or real-time communications such as instant messaging or remote assistance (a feature in Windows XP), you should enable UPnP.

---

### ➤ To turn on Universal Plug and Play:

1. Select **Advanced > Advanced Setup > UPnP**. The UPnP screen displays.

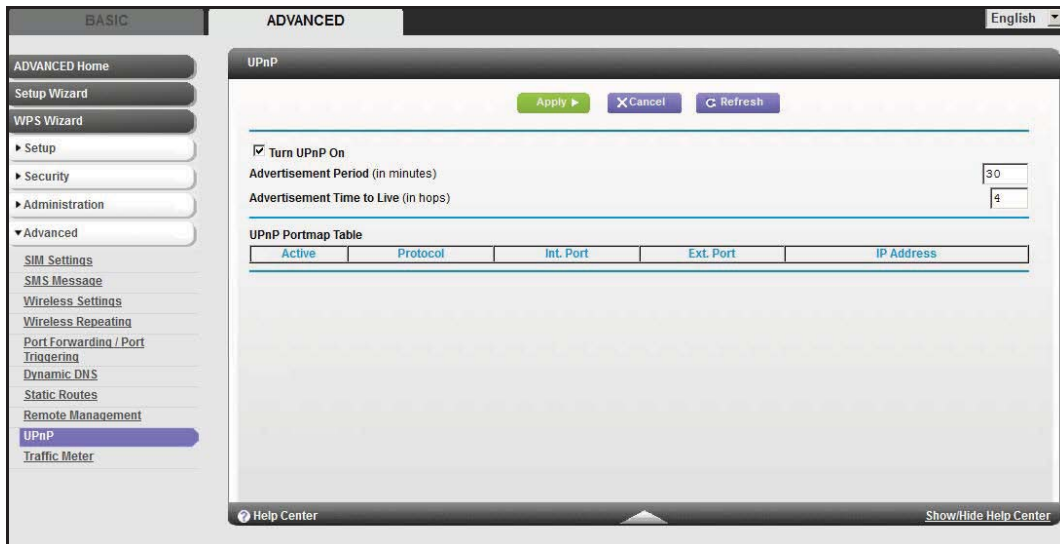

2. The available settings and information in this screen are:

**Turn UPnP On.** UPnP can be enabled or disabled for automatic device configuration. The default setting for UPnP is disabled. If this check box is not selected, the router does not allow any device to automatically control the resources, such as port forwarding (mapping) of the router.

**Advertisement Period.** The advertisement period is how often the router broadcasts its UPnP information. This value can range from 1 to 1440 minutes. The default period is 30 minutes. Shorter durations ensure that control points have current device status at the expense of additional network traffic. Longer durations can compromise the freshness of the device status, but can significantly reduce network traffic.

**Advertisement Time to Live.** The time to live for the advertisement is measured in hops (steps) for each UPnP packet sent. The time to live hop count is the number of steps a broadcast packet is allowed to propagate for each UPnP advertisement before it disappears. The number of hops can range from 1 to 255. The default value for the advertisement time to live is 4 hops, which should be fine for most home networks. If you notice that some devices are not being updated or reached correctly, then it might be necessary to increase this value.

**UPnP Portmap Table.** The UPnP Portmap Table displays the IP address of each UPnP device that is currently accessing the router and which ports (internal and external) that device has opened. The UPnP Portmap Table also displays what type of port is open and whether that port is still active for each IP address.

3. Click **Apply** to save your settings.

## Traffic Meter

Traffic metering allows you to monitor the volume of Internet traffic passing through your router's Internet port. With the Traffic Meter utility, you can set limits for traffic volume, set a monthly limit, and get a live update of traffic usage.

➤ **To monitor Internet traffic:**

1. Click **Advanced > Advanced Setup > Traffic Meter** to display the following screen:

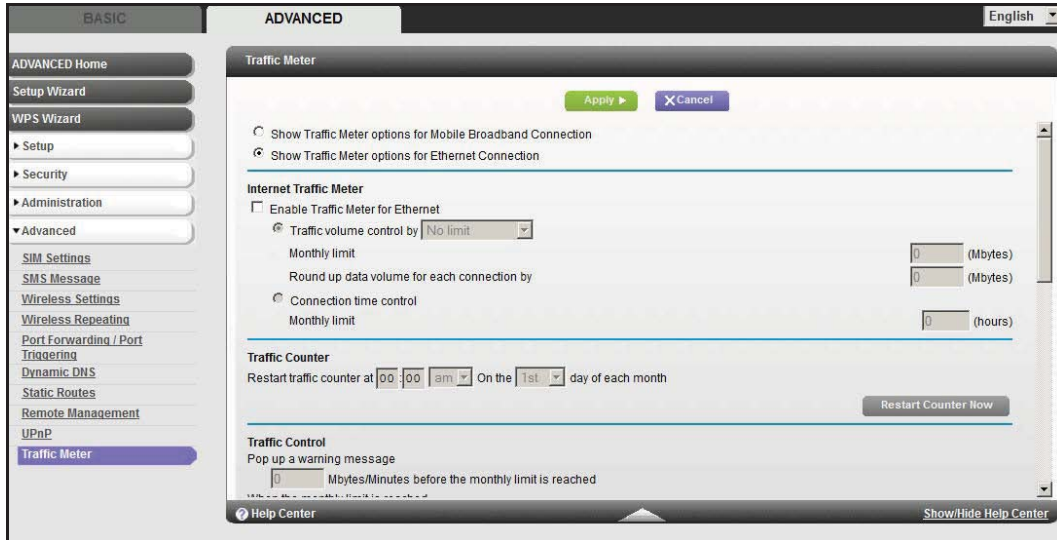

2. To enable the Traffic Meter, select the **Enable Traffic Meter** check box.
3. If you would like to record and restrict the volume of Internet traffic, select the **Traffic volume control by** radio button. You can select one of the following options for controlling the traffic volume:
  - No Limit.** No restriction is applied when the traffic limit is reached.
  - Download only.** The restriction is applied to incoming traffic only.
  - Both Directions.** The restriction is applied to both incoming and outgoing traffic.
4. You can limit the amount of data traffic allowed per month by specifying how many Mbytes per month are allowed or by specifying how many hours of traffic are allowed.
5. Set the Traffic Counter to begin at a specific time and date.
6. Set up Traffic Control to issue a warning message before the monthly limit of Mbytes or hours is reached. You can select one of the following to occur when the limit is attained:
  - The Internet LED flashes green or amber.
  - The Internet connection is disconnected and disabled.
7. Set up Internet Traffic Statistics to monitor the data traffic.
8. Click the **Traffic Status** button to get a live update on Internet traffic status on your router.
9. Click **Apply** to save your settings.



# 8 Troubleshooting

---

# 8

This chapter gives information about troubleshooting your Mobile LTE Broadband 11n Wireless Router. After each problem description, instructions are provided to help you diagnose and solve the problem. For the common problems listed, go to the section indicated.

- Is the router on?  
Go to *Basic Functioning* on page 90.
- Have I connected the router correctly?  
Go to *Basic Functioning* on page 90.
- I can't access the router's configuration with my browser.  
Go to *Troubleshoot Access to the Router Main Menu* on page 92.
- I've configured the router but I can't access the Internet.  
Go to *Troubleshoot the ISP Connection* on page 93.
- I've configured the router but I can't access my local network.  
Go to *Troubleshoot a TCP/IP Network Using the Ping Utility* on page 95.
- How do I set daylight savings time?  
Go to *Problems with Date and Time* on page 97.
- I want to clear the configuration and start over again.  
Go to *Restore the Default Configuration and Password* on page 97.

## Basic Functioning





After you turn on power to the router, the following sequence of events should occur:

1. When power is first applied, verify that the Power LED is on.
2. After approximately a minute, verify that:
  - a. The Power LED is still solid green. An amber light indicates the unit has failed its power-on self-test (POST).
  - b. The Internet Port LED is lit.
  - c. The WiFi LED is lit. The WiFi radio is on by default.
  - d. The LAN Ports LED is lit when any local ports are connected.  
 If a LAN Port LED on the back of the unit is lit, a link has been established to the connected device. If a LAN port is connected to a 100 Mbps device, verify that the port's LED is green. If the port is 10 Mbps, the LED is amber.
  - e. The WAN Port LED is lit when the router is connected to a wired modem.
  - f. The Signal Quality LED is lit when the router has detected a mobile broadband signal.

If any of these conditions does not occur, refer to the following table.

LED		Action
Power 	Power LED is off.	<ul style="list-style-type: none"> <li>• Make sure the power cord is correctly connected to your router, and that the power supply adapter is correctly connected to a functioning power outlet.</li> <li>• Check that you are using the power adapter supplied by NETGEAR for this product.</li> <li>• If the error persists, you might have a hardware problem and should contact technical support.</li> </ul>
	Power LED is amber.	There is a fault within the router. Try to clear the fault as follows: <ul style="list-style-type: none"> <li>• Cycle the power to see if the router recovers.</li> <li>• Clear the router's configuration to factory defaults. This sets the router's IP address to <a href="http://www.routerlogin.net">www.routerlogin.net</a>. This procedure is explained in <a href="#">Restore the Default Configuration and Password</a> on page 97.</li> </ul> If the error persists, you might have a hardware problem and should contact technical support.

## Mobile LTE Broadband 11n Wireless Router MBR1516

LED		Action
Internet Port 	Internet Port LED is off.	Be sure the SIM card you received is in the router. SIM cards from other devices will not function in the router, and this SIM card will not function in other devices.
	Internet Port LED is amber.	The router cannot connect to the Internet. Check the Internet connection option being used. <ul style="list-style-type: none"> <li>For the mobile broadband connection option, check the Signal Quality LEDs.</li> <li>For the Ethernet connection option, check the WAN Port LED.</li> </ul>
	Internet Port LED is blinking amber and green.	The traffic meter feature is enabled, and the limit set has been reached.
WiFi 	WiFi LED is off.	The WiFi radio has been turned off. If you want a WiFi connection with the router, press the <b>WiFi</b> button to turn the WiFi radio back on.
	WiFi LED is not blinking.	If this LED does not blink when you are attempting to send data over the WiFi link, log in to the router menu using the Ethernet LAN connection, and check your router's wireless (WiFi) configuration.
LAN Ports 	LAN Ports LED is off.	If this LED does not light when an Ethernet connection is made, check the following: <ul style="list-style-type: none"> <li>Make sure that the Ethernet cable connections are secure at the router and at the hub or workstation.</li> <li>Make sure that power is turned on to the connected hub or workstation.</li> </ul>
WAN Port 	WAN Port LED is off.	If this LED does not light when an Ethernet connection is made using the Ethernet connection option, check the following: <ul style="list-style-type: none"> <li>Make sure that the Ethernet cable connections are secure at the router and at the modem.</li> <li>Make sure that power is turned on to the modem.</li> </ul>
Signal Quality 	Signal Quality LED is off.	If this LED does not light when the mobile broadband connection option is used, check the following: <ul style="list-style-type: none"> <li>Check with your ISP to ensure that there is good coverage in the area.</li> <li>Ensure that your mobile broadband account is active.</li> <li>Ensure that the SIM card is inserted correctly into the router.</li> <li>Locate the router near the window or other area of the building. Make sure that one of the Signal Quality LEDs is lit, indicating that there is mobile broadband coverage with the router.</li> <li>Log in to the router menu and check the Internet configuration. Check that the user name, password, and APN with ISP are set correctly. If you use a PIN to connect to the Internet, make sure it is entered correctly.</li> </ul>

## Troubleshoot Access to the Router Main Menu

If you are unable to access the router main menu from a computer on your local network, check the following:

- If you are using an Ethernet-connected computer, check the Ethernet connection between the computer and the router as described in the previous section.
- Make sure your computer's IP address is on the same subnet as the router. If you are using the recommended addressing scheme, your computer's address should be in the range of 192.168.0.2 to 192.168.0.254.

---

**Note:** If your computer's IP address is shown as 169.254.x.x:  
Recent versions of Windows and MacOS generate and assign an IP address if the computer cannot reach a DHCP server. These autogenerated addresses are in the range of 169.254.x.x. If your IP address is in this range, check the connection from the computer to the router, and reboot your computer.

---

- If your router's IP address was changed and you do not know the current IP address, clear the router's configuration to factory defaults. This will set the router's IP address to [www.routerlogin.net](http://www.routerlogin.net). This procedure is explained in [Restore the Default Configuration and Password](#) on page 97.
- Make sure that your browser has Java, JavaScript, or ActiveX enabled. If you are using Internet Explorer, click **Refresh** to be sure that the Java applet is loaded.
- Try quitting the browser and launching it again.
- Make sure that you are using the correct login information. The factory default login name is **admin**, and the password is **password**. Make sure that Caps Lock is off when entering this information.

If the router does not save changes you have made in the web management interface, check the following:

- When entering configuration settings, be sure to click the **Apply** button before moving to another screen or tab, or your changes are lost.
- Click the **Refresh** or **Reload** button in the web browser. The changes might have occurred, but the web browser might be caching the old configuration.

## Troubleshoot the ISP Connection

Check these possible sources of trouble if you are having difficulty connecting to or browsing the Internet.

### Connect to the Internet

If unable to connect to Internet, check the following:

1. The Internet account is active.

If your ISP has provided you with a SIM card and you have not inserted it into the SIM card slot on the back of the router yet, do so now.

2. Wireless broadband coverage is available where the unit is located.
3. Access the router main menu to verify that the broadband settings are correct. Check with your ISP if you are unsure.
4. Check the location of the router.
  - a. Move the router closer to a window for better access to the Internet signal. A non-lighted Signal Quality LED indicates no coverage.
  - b. Maintain recommended minimum distances between NETGEAR equipment and household appliances to reduce interference.

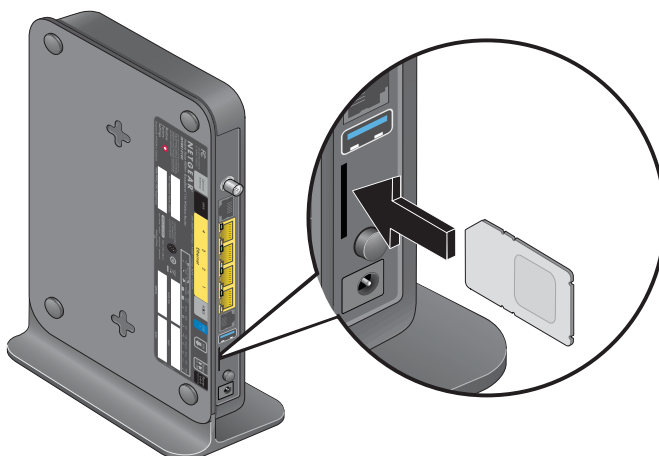

## Mobile LTE Broadband 11n Wireless Router MBR1516

5. Use external antennas for improved signal strength.

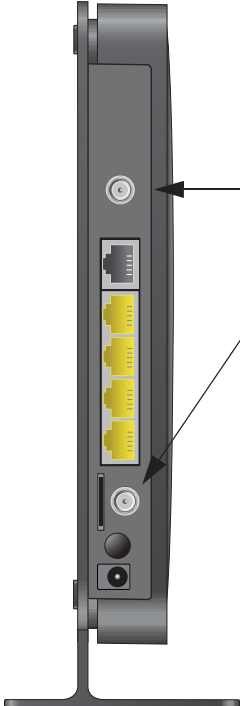

Connectors on back panel for optional external antennas

- a. Install external antennas.  
(The external antennas are an optional accessory that you can purchase.)
- b. Clear the **Use internal antenna** check box on the Mobile Broadband Settings screen, and then click **Apply**.
- c. Click **Connect** to connect to the Internet.

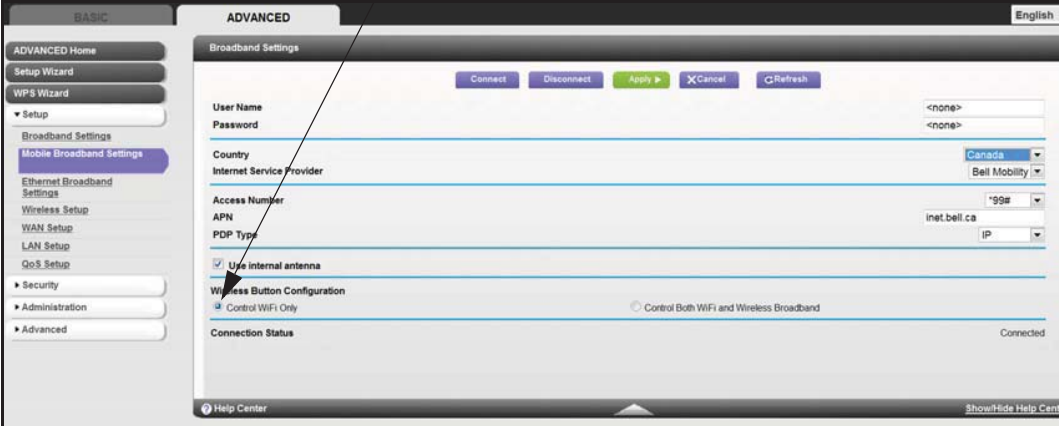

The screenshot shows the 'ADVANCED' tab of the router's web interface, specifically the 'Broadband Settings' page. The 'Use internal antenna' checkbox is checked. The 'Connection Status' is 'Connected'. The page includes fields for User Name, Password, Country (Canada), Internet Service Provider (Bell Mobility), Access Number (\*99#), APN (inet.bell.ca), and PDP Type (IP). Buttons for Connect, Disconnect, Apply, Cancel, and Refresh are visible at the top of the settings area.

## Troubleshoot Internet Browsing

If your router can obtain an IP address but your computer is unable to load any web pages from the Internet:

- The traffic meter is enabled, and the limit might have been reached.  
By configuring the traffic meter not to block, you can resume Internet access. If you have a usage limit, your ISP might charge you for the overage.
- Your computer might not recognize any DNS server addresses.  
A DNS server is a host on the Internet that translates Internet names (such as www addresses) to numeric IP addresses. Typically your ISP provides the addresses of one or two DNS servers for your use. If you entered a DNS address during the router's configuration, reboot your computer and verify the DNS address. Alternatively, you can configure your computer manually with DNS addresses, as explained in your operating system documentation.
- Your computer might not have the router configured as its TCP/IP router.  
If your computer obtains its information from the router by DHCP, reboot the computer, and verify the router address.

## Troubleshoot a TCP/IP Network Using the Ping Utility

Most TCP/IP terminal devices and routers contain a ping utility that sends an echo request packet to the designated device. The device then responds with an echo reply. You can easily troubleshoot a TCP/IP network by using the ping utility in your computer.

### Test the LAN Path to Your Router

You can ping the router from your computer to verify that the LAN path to your router is set up correctly.

➤ **To ping the router from a PC running Windows 95 or later:**

1. From the Windows toolbar, click the **Start** button, and select **Run**.
2. In the field provided, type **ping** followed by the IP address of the router, as in this example:  
`ping www.routerlogin.net`
3. Click **OK**.

You should see a message like this one:

```
Pinging <IP address> with 32 bytes of data
```

If the path is working, you see this message:

```
Reply from < IP address >: bytes=32 time=NN ms TTL=xxx
```

If the path is not working, you see this message:

Request timed out

If the path is not working correctly, you could have one of the following problems:

- Wrong physical connections
  - Make sure that the LAN Ports LED is on. If the LED is off, follow the instructions in *Connect to the Internet* on page 93.
  - Check that the corresponding link LEDs are on for your network interface card and for the hub ports (if any) that are connected to your workstation and router.
- Wrong network configuration
  - Verify that the Ethernet card driver software and TCP/IP software are both installed and configured on your computer or workstation.
  - Verify that the IP address for your router and your workstation are correct and that the addresses are on the same subnet.

## Test the Path from Your Computer to a Remote Device

After verifying that the LAN path works correctly, test the path from your computer to a remote device.

### ➤ To test the path:

1. From the Windows toolbar, click the **Start** button, and select **Run**.
2. In the Windows Run window, type:

```
ping -n 10 IP address
```

where *IP address* is the IP address of a remote device such as your ISP's DNS server.

If the path is functioning correctly, replies as in the previous section are displayed. If you do not receive replies:

- Check that your computer has the IP address of your router listed as the default router. If the IP configuration of your computer is assigned by DHCP, this information is not visible in your computer's Network Control Panel. Verify that the IP address of the router is listed as the default router.
- Make sure that the network address of your computer (the portion of the IP address specified by the netmask) is different from the network address of the remote device.
- Check that your cable or DSL modem is connected and functioning.
- If your ISP assigned a host name to your computer, enter that host name as the account name in the Basic Settings screen.
- Your ISP could be rejecting the Ethernet MAC addresses of all but one of your computers. Many broadband ISPs restrict access by allowing only traffic from the MAC address of your broadband modem, but some ISPs additionally restrict access to the MAC address of a single computer connected to that modem. If this is the case, you need to configure your router to clone or spoof the MAC address from the authorized computer.



## Problems with Date and Time

The Email screen displays the current date and time of day. The Mobile LTE Broadband 11n Wireless Router uses the Network Time Protocol (NTP) to obtain the current time from one of several network time servers on the Internet. Each entry in the log is stamped with the date and time of day. Problems with the date and time function can include the following:

- Date shown is January 1, 2000.  
Cause: The router has not yet successfully reached a network time server. Check that your Internet access settings are configured correctly. If you have just completed configuring the router, wait at least 5 minutes, and check the date and time again.
- Time is off by one hour.  
Cause: The router does not automatically sense daylight savings time. On the E-mail screen, select or clear the **Automatically adjust for Daylight Savings Time** check box.

## Restore the Default Configuration and Password

This section explains how to restore the factory default configuration settings, changing the router's admin password to **password** and the IP address to **www.routerlogin.net**. You can erase the current configuration and restore factory defaults in two ways:

- Use the Erase feature (see [Erase](#) on page 61).
- Press the **Restore Factory Settings** button on the bottom of the router for 6 seconds. Use this method for cases when the administration password or IP address is not known.

The factory default settings are shown in [Factory Default Settings](#) on page 99.

# A Supplemental Information

---



This appendix provides the following information:

- *Factory Default Settings*
- *Technical Specifications*

## Factory Default Settings

Use the Restore Factory Settings button located on the bottom of your router to reset all settings to their original factory default settings. This is called a hard reset. To perform a hard reset, press and hold the **Restore Factory Settings** button for 6 seconds. Your router will return to the factory configuration settings that are shown in the following table.

Feature		Default behavior
Router login	User login URL	http://www.routerlogin.net or http://www.routerlogin.com
	User name (case-sensitive)	admin
	Login password (case-sensitive)	password
Internet connection	WAN MAC address	Use default address
	WAN MTU size	1500
	Port speed	AutoSense
Local network (LAN)	LAN IP	www.routerlogin.net
	Subnet mask	255.255.255.0
	RIP direction	None
	RIP version	Disabled
	RIP authentication	None
	DHCP server	Enabled
	DHCP starting IP address	192.168.0.2
	DHCP ending IP address	192.168.0.254
	DMZ	Disabled
	Time zone	PST for North America
	Daylight savings time adjustment	Enabled
Firewall	Inbound communication from the Internet	Disabled (except traffic on port 80, the HTTP port)
	Outbound communication to the Internet)	Enabled (all)
	Source MAC filtering	Disabled

## Mobile LTE Broadband 11n Wireless Router MBR1516

Feature (continued)		Default behavior (continued)
Mobile broadband	Internet service provider	Bell Mobility
	APN	inet.bell.ca
	Access Number	*99#
	PDP Type	IP
	User Name	None required
WiFi	Wireless communication	Enabled
	SSID name	See label on the bottom of router
	Security	WPA-PSK/WPA2-PSK mixed mode
	Broadcast SSID	Enabled
	Transmission speed	Auto (Maximum wireless signal rate derived from IEEE Standard 802.11 specifications. Actual throughput will vary. Network conditions and environmental factors, including volume of network traffic, building materials and construction, and network overhead, lower actual data throughput rate.)
	Country/region	Canada
	RF channel	Auto
	Operating mode	Up to 145 Mbps
	Data rate	Best
	Output power	Full
	Access point	Enabled
	Authentication type	Open system
	Wireless Card Access List	All wireless stations allowed

## Technical Specifications

Technical specifications	
Network protocol and standards compatibility	TCP/IP, DHCP
Power adapter	<ul style="list-style-type: none"> <li>North America: 120V AC, 60 Hz, input</li> <li>12V DC @ 2.5A output</li> </ul>
Physical specifications	<ul style="list-style-type: none"> <li>Dimensions: 6.8 in. x 5.03 in. x 1.28 in. (173 mm x 128 mm x 33 mm)</li> <li>Weight: 0.65 lbs without the stand (0.29 kg)</li> </ul>
Environmental specifications	<ul style="list-style-type: none"> <li>Operating temperature: 0° to 40°C (32° to 104°F)</li> <li>Operating humidity: 90% maximum relative humidity, noncondensing</li> </ul>
Electromagnetic emissions	FCC Part 15 Class B; IC; EN 55 022 (CISPR 22), Class B
Interface specifications	<ul style="list-style-type: none"> <li>LAN: 10BASE-T or 100BASE-Tx, RJ-45</li> <li>WAN: 10BASE-T or 100BASE-TX, RJ-45</li> </ul>
Antenna connection (optional)	<ul style="list-style-type: none"> <li>SMA connector</li> </ul>

# Notification of Compliance



## NETGEAR Wireless Routers, Gateways, APs

### Regulatory Compliance Information

Note: This section includes user requirements for operating this product in accordance with National laws for usage of radio spectrum and operation of radio devices. Failure of the end-user to comply with the applicable requirements may result in unlawful operation and adverse action against the end-user by the applicable National regulatory authority.

Note: This product's firmware limits operation to only the channels allowed in a particular Region or Country. Therefore, all options described in this user's guide may not be available in your version of the product.

### Europe – EU Declaration of Conformity



Marking by the above symbol indicates compliance with the Essential Requirements of the R&TTE Directive of the European Union (1999/5/EC). This equipment meets the following conformance standards:

EN300 328 (2.4Ghz), EN301 489-17 EN60950-1

For complete DoC, visit the NETGEAR EU Declarations of Conformity website at:

[http://support.netgear.com/app/answers/detail/a\\_id/11621](http://support.netgear.com/app/answers/detail/a_id/11621)

### EDOC in Languages of the European Community

Language	Statement
Cesky [Czech]	<i>NETGEAR Inc.</i> tímto prohlašuje, že tento Radiolan je ve shode se základními požadavky a dalšími příslušnými ustanoveními směrnice 1999/5/ES.
Dansk [Danish]	Undertegnede <i>NETGEAR Inc.</i> erklærer herved, at følgende udstyr Radiolan overholder de væsentlige krav og øvrige relevante krav i direktiv 1999/5/EF.
Deutsch [German]	Hiermit erkläre <i>NETGEAR Inc.</i> , dass sich das Gerät Radiolan in Übereinstimmung mit den grundlegenden Anforderungen und den übrigen einschlägigen Bestimmungen der Richtlinie 1999/5/EG befindet.
Eesti [Estonian]	Käesolevaga kinnitab <i>NETGEAR Inc.</i> seadme Radiolan vastavust direktiivi 1999/5/EÜ põhinõuetele ja nimetatud direktiivist tulenevatele teistele asjakohastele sätetele.
English	Hereby, <i>NETGEAR Inc.</i> , declares that this Radiolan is in compliance with the essential requirements and other relevant provisions of Directive 1999/5/EC.

## Mobile LTE Broadband 11n Wireless Router MBR1516

Language	Statement
Español [Spanish]	Por medio de la presente <i>NETGEAR Inc.</i> declara que el Radiolan cumple con los requisitos esenciales y cualesquiera otras disposiciones aplicables o exigibles de la Directiva 1999/5/CE.
Ελληνική [Greek]	ΜΕ ΤΗΝ ΠΑΡΟΥΣΑ <i>NETGEAR Inc.</i> ΔΗΛΩΝΕΙ ΟΤΙ Radiolan ΣΥΜΜΟΡΦΩΝΕΤΑΙ ΠΡΟΣ ΤΙΣ ΟΥΣΙΩΔΕΙΣ ΑΠΑΙΤΗΣΕΙΣ ΚΑΙ ΤΙΣ ΛΟΙΠΕΣ ΣΧΕΤΙΚΕΣ ΔΙΑΤΑΞΕΙΣ ΤΗΣ ΟΔΗΓΙΑΣ 1999/5/ΕΚ.
Français [French]	Par la présente <i>NETGEAR Inc.</i> déclare que l'appareil Radiolan est conforme aux exigences essentielles et aux autres dispositions pertinentes de la directive 1999/5/CE.
Italiano [Italian]	Con la presente <i>NETGEAR Inc.</i> dichiara che questo Radiolan è conforme ai requisiti essenziali ed alle altre disposizioni pertinenti stabilite dalla direttiva 1999/5/CE.
Latviski [Latvian]	Ar šo <i>NETGEAR Inc.</i> deklarē, ka Radiolan atbilst Direktīvas 1999/5/EK būtiskajām prasībām un citiem ar to saistītajiem noteikumiem.
Lietuvių [Lithuanian]	Šiuo <i>NETGEAR Inc.</i> deklaruoja, kad šis Radiolan atitinka esminius reikalavimus ir kitas 1999/5/EB Direktyvos nuostatas.
Nederlands [Dutch]	Hierbij verklaart <i>NETGEAR Inc.</i> dat het toestel Radiolan in overeenstemming is met de essentiële eisen en de andere relevante bepalingen van richtlijn 1999/5/EG.
Malti [Maltese]	Hawnhekk, <i>NETGEAR Inc.</i> , jiddikjara li dan Radiolan jikkonforma mal-htigijiet essenzjali u ma provvedimenti oħrajn relevanti li hemm fid-Dirrettiva 1999/5/EC.
Magyar [Hungarian]	Alulírott, <i>NETGEAR Inc.</i> nyilatkozom, hogy a Radiolan megfelel a vonatkozó alapvető követelményeknek és az 1999/5/EC irányelv egyéb előírásainak.
Polski [Polish]	Niniejszym <i>NETGEAR Inc.</i> oświadcza, że Radiolan jest zgodny z zasadniczymi wymogami oraz pozostałymi stosownymi postanowieniami Dyrektywy 1999/5/EC.
Português [Portuguese]	<i>NETGEAR Inc.</i> declara que este Radiolan está conforme com os requisitos essenciais e outras disposições da Directiva 1999/5/CE.
Slovensko [Slovenian]	<i>NETGEAR Inc.</i> izjavlja, da je ta Radiolan v skladu z bistvenimi zahtevami in ostalimi relevantnimi določili direktive 1999/5/ES.
Slovensky [Slovak]	<i>NETGEAR Inc.</i> týmto vyhlasuje, že Radiolan spĺňa základné požiadavky a všetky príslušné ustanovenia Smernice 1999/5/ES.
Suomi [Finnish]	<i>NETGEAR Inc.</i> vakuuttaa täten että Radiolan tyyppinen laite on direktiivin 1999/5/EY oleellisten vaatimusten ja sitä koskevien direktiivin muiden ehtojen mukainen.
Svenska [Swedish]	Härmed intygar <i>NETGEAR Inc.</i> att denna Radiolan står i överensstämmelse med de väsentliga egenskapskrav och övriga relevanta bestämmelser som framgår av direktiv 1999/5/EG.

## Mobile LTE Broadband 11n Wireless Router MBR1516

Language	Statement
Íslenska [Icelandic]	Hér með lýsir <i>NETGEAR Inc.</i> yfir því að Radiolan er í samræmi við grunnkröfur og aðrar kröfur, sem gerðar eru í tilskipun 1999/5/EC.
Norsk [Norwegian]	<i>NETGEAR Inc.</i> erklærer herved at utstyret <i>Radiolan</i> er i samsvar med de grunnleggende krav og øvrige relevante krav i direktiv 1999/5/EF.

This device is a 2.4 GHz wideband transmission system (transceiver), intended for use in all EU member states and EFTA countries, except in France and Italy where restrictive use applies.

In Italy the end-user should apply for a license at the national spectrum authorities in order to obtain authorization to use the device for setting up outdoor radio links and/or for supplying public access to telecommunications and/or network services.

This device may not be used for setting up outdoor radio links in France and in some areas the RF output power may be limited to 10 mW EIRP in the frequency range of 2454 - 2483.5 MHz. For detailed information the end-user should contact the national spectrum authority in France.

### FCC Requirements for Operation in the United States

#### FCC Information to User

This product does not contain any user serviceable components and is to be used with approved antennas only. Any product changes or modifications will invalidate all applicable regulatory certifications and approvals.

#### FCC Guidelines for Human Exposure

This equipment complies with FCC radiation exposure limits set forth for an uncontrolled environment. This equipment should be installed and operated with minimum distance of 35 cm between the radiator and your body. This transmitter must not be co-located or operating in conjunction with any other antenna or transmitter.

#### FCC Declaration of Conformity

We, NETGEAR, Inc., 350 East Plumeria Drive, San Jose, CA 95134, declare under our sole responsibility that the Mobile LTE Broadband 11n Wireless Router MBR1516 complies with Part 15 Subpart B of FCC CFR47 Rules. Operation is subject to the following two conditions:

- This device may not cause harmful interference, and
- This device must accept any interference received, including interference that may cause undesired operation.

#### FCC Radio Frequency Interference Warnings & Instructions

This equipment has been tested and found to comply with the limits for a Class B digital device, pursuant to Part 15 of the FCC Rules. These limits are designed to provide reasonable protection against harmful interference in a residential installation. This equipment uses and can radiate radio frequency energy and, if not installed and used in accordance with the instructions, may cause harmful interference to radio communications. However, there is no guarantee that interference will not occur in a particular installation. If this equipment does cause harmful interference to radio or television reception, which can be determined by turning the equipment off and on, the user is encouraged to try to correct the interference by one or more of the following methods:

- Reorient or relocate the receiving antenna.
- Increase the separation between the equipment and the receiver.
- Connect the equipment into an electrical outlet on a circuit different from that which the radio receiver is connected.
- Consult the dealer or an experienced radio/TV technician for help.

#### FCC Caution

- Any changes or modifications not expressly approved by the party responsible for compliance could void the user's authority to operate this equipment.



## Mobile LTE Broadband 11n Wireless Router MBR1516

- This device complies with Part 15 of the FCC Rules. Operation is subject to the following two conditions: (1) This device may not cause harmful interference, and (2) this device must accept any interference received, including interference that may cause undesired operation.
- For product available in the USA market, only channel 1~11 can be operated. Selection of other channels is not possible.
- This device and its antenna(s) must not be co-located or operation in conjunction with any other antenna or transmitter.

### Canadian Department of Communications Radio Interference Regulations

This digital apparatus (Mobile LTE Broadband 11n Wireless Router MBR1516) does not exceed the Class B limits for radio-noise emissions from digital apparatus as set out in the Radio Interference Regulations of the Canadian Department of Communications.

This Class [B] digital apparatus complies with Canadian ICES-003.

Cet appareil numérique de la classe [B] est conforme à la norme NMB-003 du Canada

### Industry Canada

This device complies with RSS-210 of the Industry Canada Rules. Operation is subject to the following two conditions: (1) This device may not cause harmful interference, and (2) this device must accept any interference received, including interference that may cause undesired operation.

### IMPORTANT NOTE: Radiation Exposure Statement:

This equipment complies with IC radiation exposure limits set forth for an uncontrolled environment. This equipment should be installed and operated with minimum distance 35cm between the radiator & your body.

### Caution:

Ce dispositif est conforme à la norme CNR-210 d'Industrie Canada applicable aux appareils radio exempts de licence. Son fonctionnement est sujet aux deux conditions suivantes: (1) le dispositif ne doit pas produire de brouillage préjudiciable, et (2) ce dispositif doit accepter tout brouillage reçu, y compris un brouillage susceptible de provoquer un fonctionnement indésirable.

### NOTE IMPORTANTE: Déclaration d'exposition aux radiations:

Cet équipement est conforme aux limites d'exposition aux rayonnements IC établies pour un environnement non contrôlé. Cet équipement doit être installé et utilisé avec un minimum de 35 cm de distance entre la source de rayonnement et votre corps.

For product available in the USA/Canada market, only channel 1~11 can be operated. Selection of other channels is not possible.<sup>†</sup>

*Pour les produits disponibles aux États-Unis / Canada du marché, seul le canal 1 à 11 peuvent être exploités. Sélection d'autres canaux n'est pas possible.<sup>†</sup>*

This device and its antenna(s) must not be co-located or operation in conjunction with any other antenna or transmitter.<sup>†</sup>

*Cet appareil et son antenne (s) ne doit pas être co-localisés ou fonctionner en association avec une autre antenne ou transmetteur.<sup>†</sup>*

## Mobile LTE Broadband 11n Wireless Router MBR1516

### Interference Reduction Table

The table below shows the Recommended Minimum Distance between NETGEAR equipment and household appliances to reduce interference (in feet and meters).

Household Appliance	Recommended Minimum Distance (in feet and meters)
Microwave ovens	30 feet / 9 meters
Baby Monitor - Analog	20 feet / 6 meters
Baby Monitor - Digital	40 feet / 12 meters
Cordless phone - Analog	20 feet / 6 meters
Cordless phone - Digital	30 feet / 9 meters
Bluetooth devices	20 feet / 6 meters
ZigBee	20 feet / 6 meters

# Index

## A

- access
  - remote **85**
  - viewing logs **59**
- access points **70**
- accessing remote computer **73**
- adding
  - custom service **78**
- address reservation **43**
- advertisement period **87**
- alerts, emailing **54**
- attached devices **26**
- authentication, required by mail server **54**
- automatic firmware checking **63, 64**

## B

- backing up configuration **60**
- base station, setting up **72**
- blocking
  - inbound traffic **73**
  - keywords **50**
  - services **51**
  - sites **50**
- box contents **7**
- broadband settings **36**

## C

- compliance **102**
- configuration file **60**
- configuring
  - DMZ server **39**
  - Dynamic DNS **82**
  - NAT **38**
  - port forwarding **77**
  - port triggering **79**
  - repeater unit **73**
  - user-defined services **51**
- connecting wirelessly **14**
- control buttons **8**
- country setting **33**
- CTS/RTS Threshold **68**

- custom service (port forwarding) **78**

## D

- dashboard **19**
- data packets, fragmented **39**
- date and time **97**
- daylight savings time **97**
- default DMZ server **39**
- default factory settings, restoring **61**
- default gateway **58**
- deleting
  - configuration **61**
  - keywords **50**
- denial of service (DoS) protection **49**
- devices, attached **26**
- DHCP server **42, 59**
- DHCP setting **56**
- DMZ server **39**
- DNS servers **74**
- Domain Name Server (DNS) addresses **23, 57**
- Dynamic DNS **81**
- DynDNS.org **81**

## E

- email notices **54**
- erasing configuration **61**

## F

- factory default settings, restoring **61**
- factory defaults **11**
- firmware version **56**
- firmware, upgrading **18, 63, 64**
- fragmentation length **68**
- fragmented data packets **39**
- front panel **90**

## G

- gateway IP address **23**
- genie, NETGEAR **17**

## H

host name [22](#)  
host, trusted [50](#)

## I

inbound traffic, allowing or blocking [73](#)  
installing NETGEAR genie [17](#)  
installing with the Setup Wizard [33](#)  
Internet connection  
    setting up [22](#)  
internet port LED [9](#), [91](#)  
Internet Relay Chat (IRC) [75](#)  
Internet service provider (ISP)  
    account information [16](#)  
    Internet Setup screen [22](#)  
    login [16](#)  
Internet services, blocking access [51](#)  
Internet Setup screen [22](#)  
interval, poll [58](#)  
IP addresses  
    auto-generated [92](#)  
    current [56](#)  
    DHCP [16](#)  
    dynamic [81](#)  
    reserved [43](#)  
IP subnet mask [57](#)

## K

keywords [50](#)

## L

LAN setup [41](#)  
language setting [33](#)  
lease, DHCP [59](#)  
LED descriptions [9](#)  
local servers, port forwarding to [77](#)  
logging in [16](#), [18](#)  
logs  
    emailing [54](#)  
    viewing [59](#)

## M

MAC address [96](#)  
mail server, outgoing [54](#)  
maintenance settings [55](#)  
managing router remotely [85](#)  
menus, described [19](#)

metric value [84](#)  
mobile broadband settings [36](#)  
MTU size [39](#)  
multicasting [42](#)

## N

NAT (Network Address Translation) [38](#), [39](#), [74](#)  
NETGEAR genie [17](#)  
Network Time Protocol (NTP) [97](#)

## O

outgoing mail server [54](#)

## P

packets, fragmented [39](#)  
Parental Controls [27](#)  
passphrases  
    changing [26](#)  
password  
    restoring [97](#)  
password recovery, admin [62](#)  
poll interval [58](#)  
port filtering [51](#)  
port forwarding [73](#), [76](#), [77](#)  
port numbers [51](#)  
port status [57](#)  
port triggering [73](#), [75](#), [77](#), [79](#)  
ports  
    LAN [9](#), [91](#)  
    WAN [9](#), [91](#)  
positioning the router [14](#)  
power LED [9](#), [90](#)  
Preamble mode [68](#)  
preset security  
    about [24](#)  
    passphrase [26](#)  
primary DNS addresses [23](#)  
prioritizing traffic [44](#)  
Push 'N' Connect [20](#)

## Q

QoS (Quality of Service) [44](#)

## R

radio, wireless [68](#)  
range of wireless connections [14](#)

- recovering admin password **62**
- remote management **85**
- repeater units **72**
- reserved IP addresses **43**
- restore factory defaults **11**
- restoring
  - configuration file **60**
  - default factory settings **61**
- router interface, described **19**
- router status, viewing **56**

## S

- scheduling keyword and service blocking **53**
- secondary DNS **23**
- security **24**
  - firewall settings **49**
- security PIN **34**
- sending logs by email **54**
- services, blocking **51**
- Setup Wizard **33**
- signal quality **10, 91**
- sites, blocking **50**
- SMS (Short Message Service), configuring **31**
- SMS LED **9**
- SMTP server **54**
- SSID, described **25**
- static routes **82**
- status LEDs **8, 90**
- status, router, viewing **56**
- subnet mask **57**
- system up time **57**

## T

- TCP/IP network, troubleshooting **95**
- technical support **2**
- time of day **97**
- time to live, advertisement **87**
- time-out, port triggering **81**
- trademarks **2**
- traffic metering **87**
- troubleshooting **89**
- trusted host **50**

## U

- Universal Plug and Play (UPnP) **86**
- up time, system **57**
- upgrading firmware **18, 63, 64**

- user-defined services **51**

## V

- viewing
  - logs **59**
  - router status **56**

## W

- WAN port LED **9, 91**
- WAN setup **38**
- Wi-Fi
  - LED **9**
- WiFi
  - button **9, 91**
- Wi-Fi Protected Setup (WPS) **20, 34**
  - devices, adding **20**
- wireless channel **25**
- wireless connections **14**
- wireless devices, adding to the network **20**
- Wireless Distribution System (WDS) **70, 71**
- wireless mode **25**
- wireless network name (SSID)
  - broadcast **25**
  - described **25**
- wireless network settings **25**
- wireless radio **68**
- wireless repeating **70, 71**
  - base station **72**
  - repeater unit **72**
- wireless settings **24**
  - SSID broadcast **25**
- WMM (Wi-Fi Multimedia) **44**
- WPS
  - 9**
- WPS button **20**