

Digital Paper System

Quick Start Guide



**Help Guide (online manual)**  
This Quick Start Guide explains how to use the device for the first time and gives safety precautions. For further details, refer to the online Help Guide:

<http://www.sony.net/dpt-rp1/help>



DPT-CP1

© 2017 Sony Corporation / Printed in China

Owner's Record

The model and serial number are located at the rear of the device. Record the serial number in the space provided below. Refer to these numbers whenever you contact your Sony dealer regarding this product.  
Model No. DPT-CP1  
Serial No. \_\_\_\_\_

Getting Started

Checking the supplied items

Check the following items are present.

- Digital Paper device (1)
- Stylus (1)
- Replacement tips
  - Felt (gray) (1)
  - POM (black) (2)
- Tip puller (1)
- USB cable (1)
- Quick Start Guide (this document) (1)
- Warranty (1)

Tip

For approved accessories, refer to the following Digital Paper product page:  
<https://www.sony.com/electronics/mobile-tablets>

Initial setup

Set up the Digital Paper device (hereafter referred to as "the device") and your computer according to the instructions displayed.

- 1 Turn on the device.
- 2 Set a stylus according to the instructions on the screen.
- 3 Turn on the computer and connect to the Internet.
- 4 Download Digital Paper App from the following site and install on the computer.  
<http://www.sony.net/dpapp>  
Digital Paper App is required to transfer documents (PDF files).
- 5 Start Digital Paper App and connect the supplied USB cable to the micro USB connector of the device and the USB connector of the computer.
- 6 Set the computer according to the instructions displayed by Digital Paper App.  
Documents can be transferred only between the device and the computer.
- 7 Update the app software if a software update is advised.

Note

Wi-Fi is used only for transferring documents between the device and the computer. The device cannot display Internet content.

Charging the device and stylus

- 1 Turn on the computer.
- 2 Connect the supplied USB cable to the micro USB connector of the device or stylus and the USB connector of the computer.

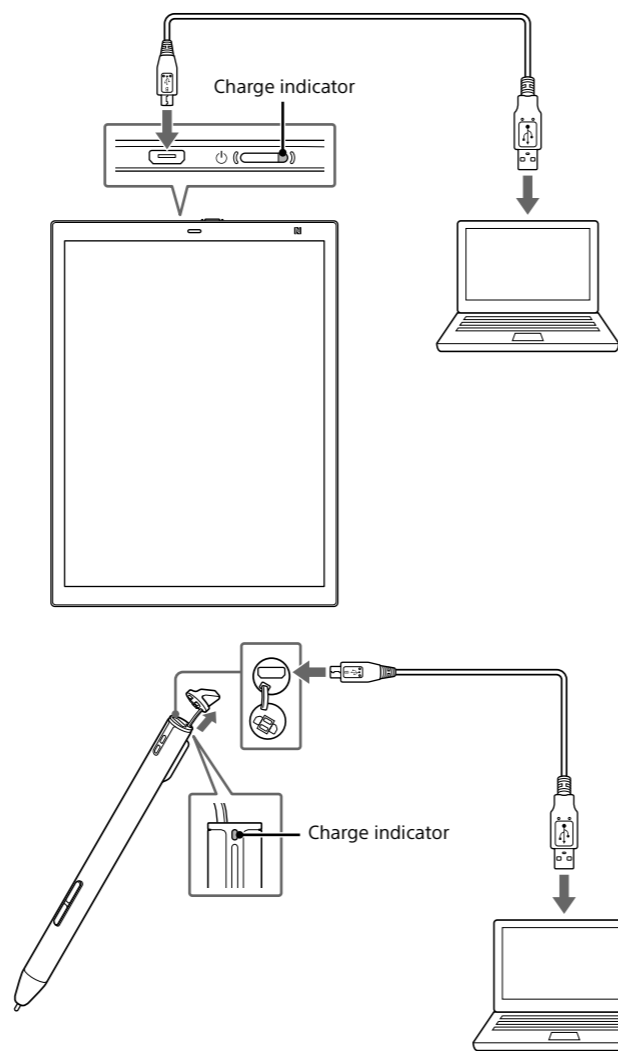

Notes

- Charge the device and stylus within the recommended temperature range of 5 °C to 35 °C (41 °F to 95 °F). If the room is too hot or cold, disconnect the USB cable, adjust the room temperature accordingly, then reconnect the USB cable to charge.
- The device and stylus will not charge if your computer is turned off, enters sleep mode, standby mode or hibernation mode.

Tip

The Charge indicator lights up in red while charging.

Parts and controls

Digital Paper device

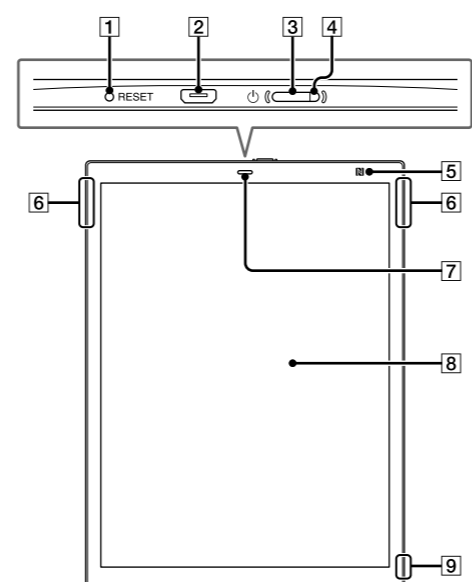

- |                       |                                   |
|-----------------------|-----------------------------------|
| 1 RESET button        | 6 Magnet (for holding the stylus) |
| 2 Micro USB connector | 7 (home) button                   |
| 3 (power) button      | 8 Touchscreen                     |
| 4 Charge indicator    | 9 Strap hole                      |
| 5 (N-Mark)            |                                   |

Stylus

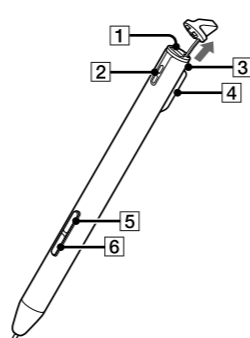

- |                       |                                  |
|-----------------------|----------------------------------|
| 1 Micro USB connector | 4 Part for holding to the device |
| 2 Strap hole          | 5 Highlight button               |
| 3 Charge indicator    | 6 Eraser button                  |

Troubleshooting

The following information will help you remedy problems if you cannot operate the device.

- 1 Charge the device and the stylus.
- 2 Reset the device.  
Press the RESET button with a plastic toothpick, clip, etc.  
Press the (power) button to restart the device.

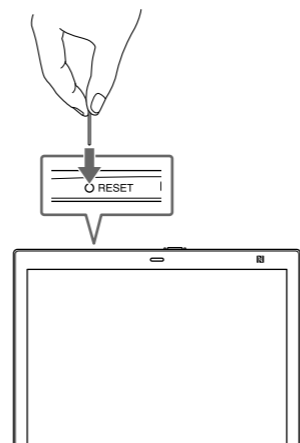

Notes

- Content handwritten within documents, created notes, and settings may be deleted when the device is reset.
- Do not press the RESET button with a fragile object (pencil lead, etc.).

How to use the system and the support site

For more detailed information on using the Digital Paper System, see <http://www.sony.com/digitalpapersupport>

If you cannot recover the device

Consult the Sony Support Center and provide the following information.

- Model name (specified on the back panel)
- Serial number (specified on the back panel)
- Purchase date

Replacing the stylus tip

The stylus tip may wear out through use. It is recommended to replace the tip when it becomes shorter than 1.5 mm (1/16 in). Replacement tips and a tip puller are supplied with the device.

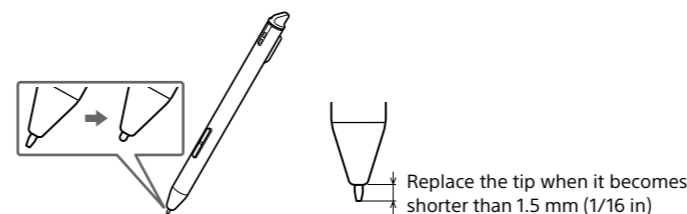

- 1 Pinch the tip with the supplied tip puller, then pull it out straight.

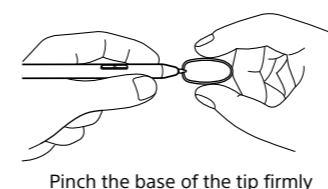

- 2 Check the orientation of the replacement tip, pinch it with the tip puller, then push it straight into the stylus.

- 3 Push the tip firmly with your finger.

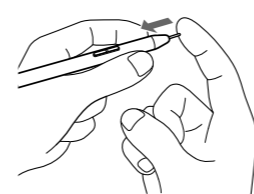

Notes

- Keep out of reach of children, as the tip may be swallowed. In case the tip is swallowed, please consult your doctor.
- Pressing on the tip with excessive pressure will wear it out more quickly.

Tips

- Replace the stylus tip periodically to prevent damage to the device and maintain consistent operation.
- If the stylus tip is lost, contact the Sony Support Center.

Important Information

Safety

Do not expose the battery to fire or heat.

Do not disassemble the battery.

It may cause electric shock. Do not remove the battery yourself. For battery replacement, internal checking or repair, consult the Sony Support Center.

Do not charge the device near fire, heat, or leave it in hot sunlight.

Do not leave coins, keys, jewelry, etc., near the USB connector or USB cable.

Do not use the device while moving.

Do not operate the device or watch the display while driving a vehicle, riding a motor cycle, walking, etc.

Do not use the device where it may distract you from danger; for example at a railroad crossing, road, construction site, etc.

Be careful not to allow liquid or a foreign object to get into the device, as doing so may cause electric shock or fire. If liquid or a foreign object gets into the device, consult the Sony Support Center.

Keep out of reach of children.

The stylus or replacement tip may be accidentally swallowed. If the battery is swallowed, consult a doctor immediately. It may cause choking or damage the stomach.

Never subject the device to high temperature.

Never subject the device to extremes of light, high temperature (more than 60 °C (140°F)), moisture or vibration. For example, if the device is left in a car parked in the sun, excessive heat buildup may result in deformation of the device casing, or other malfunction.

Do not cover the device with a blanket when turned on. The device may overheat and deform or catch fire.

If you feel discomfort while using the device, stop using it.

Do not leave the device on an unstable surface.

Do not leave the device on an unstable or sloping surface. Do not stand the device upright, or turn it upside down. The device may drop or be damaged.

The device screen is delicate.

If heavy weight or force is applied, the screen may be damaged.

Precautions

Safety

Handling the device

- If the device causes interference to radio or television reception, turn the device off and move it away from the radio or television.
- Refrain from using the device in an aircraft according to the in-flight announcements during taking off or landing.
- When you put the device into a bag, make sure no objects with sharp or hard edges come into direct contact with the device.
- Do not drop, or put any heavy object on top of the device or apply a strong shock to the device. It may cause a malfunction or damage.
- Never subject the device to extremes of light, temperature, moisture or vibration.
- If part of the device that generates heat contacts your skin for a prolonged period, you may suffer burn symptoms, such as redness, swelling, even if the temperature is moderate. Avoid prolonged contact, especially if you have sensitive skin.
- Do not leave the device on an unstable surface.
- Do not poke people with the supplied stylus.
- Do not treat or use the supplied stylus roughly, such as bending it, or scratching the touchscreen with it.
- Use the supplied stylus only for touchscreen operations.
- Do not use the stylus if it is damaged or deformed.
- Do not subject the stylus to shock or vibration.
- Do not apply any excessive pressure to the stylus tip and stylus button during operation.
- Do not keep the stylus tip pressed while the stylus is not in use.
- Do not leave the stylus on the touchscreen. It wastes battery charge of the device and stylus.
- If an object is placed on the touchscreen, it may cause a malfunction. When not in use, leave the device in sleep mode, or turn it off.
- When using the device another country/region, it is your responsibility to ensure that it is used in compliance with the following specifications:
  - AC voltage
  - Wireless products regulations
  - Other safety regulations or requirements
- Be sure not to short-circuit the terminals of the device with metallic objects.
- Never leave the device exposed to high temperature, such as in a car parked in the sun or under direct sunlight.
- As the device uses magnets, it may affect medical equipment such as a cardiac pacemaker, defibrillator, or programmable shunt valve. Do not put the device close to medical equipment or people using medical equipment. If you use medical equipment and feel anxious, consult your doctor before you use the device.

Avoiding water and moisture

- If the unit is suddenly taken from a cold to a warm location, or if ambient temperature suddenly rises, moisture may form on the outer surface of the unit and/or inside of the unit. This is known as condensation. If condensation occurs, turn off the unit and wait until the condensation clears before operating the unit. Operating the unit while condensation is present may damage the unit.
  - The device is not waterproof. Remember to follow the precautions below.
    - Be careful not to drop the device into a sink or other container filled with water.
    - Do not use the device in humid locations or bad weather, such as in the rain or snow.
    - Do not get the device wet.
- If you touch the device with wet hands, or put it in a damp article of clothing, the device may get wet and this may cause a malfunction.

Charging the device

- Heat may build up in the device while charging, or if it is used for an extended period of time.
- Use the supplied USB cable only. Do not use any other USB cable.
- Never wrap the device in anything when it is being charged. Heat build-up in the device may cause malfunction or damage.
- If the battery lasts only half the normal time even after being fully charged, it may be reaching the end of its life.

Cleaning the device

- Clean the device with a soft cloth, such as a cleaning cloth for eyeglasses. Make sure that there is no dust or dirt on the soft cloth, as the device may be damaged.
- Do not use any type of abrasive pad, scouring powder or solvent, such as alcohol or benzene, as it may mar the finish of the case.
- Wipe the stylus with a dry cloth when it gets dirty. Tapping or dragging on the touchscreen using a dirty stylus may damage the surface.
- Be sure to keep the device away from water or spills.

Regulatory information

This device displays the information below.

- The Declaration of Conformity (DoC) logo and the FCC Identifier (FCC ID) based on the FCC Rules
- The VCCI mark based on RULES FOR VOLUNTARY CONTROL MEASURES
- The marks and registration numbers of the radio wave and radio communication acts

You can display these marks or registration numbers.

Press the (home) button, then tap [Settings] - [Regulatory Information].

If you cannot display the marks or registration numbers due to a malfunction, contact the Sony Support Center.

End User License Agreement

- You can display the End User License Agreement from the [Settings].  
Press the (home) button, then tap [Settings] ▶ [System Information] ▶ [End User License Agreement].

Display

- The display is made of plastic film to be thin and lightweight. When the device is illuminated, distortion of the plastic film may occur. This is not a malfunction.
- Do not apply excessive pressure to the touchscreen. The color or brightness may become uneven and may cause the device to malfunction.
- When using the device in a cold environment, the screen may change at a slower speed. This is not a malfunction.

## Security

You can lock the screen lock on the device. When the screen lock is on, entering the lock password will be required when the device is turned on or the device is woken from sleep mode.

To set the lock password, press the  (home) button, then tap [Settings] ▶ [Screen Lock] ▶ [Screen Lock] ▶ [Enable]. The lock password should be between 4 to 20 alphanumeric characters and symbols.

– Do not create a lock password that other people could easily guess. Change your password periodically.

– Be sure to remember your lock password. If you forget your lock password, contact the Sony Support Center. The device may be unlocked. However, all documents stored on the device will be deleted.

– When the device is woken from sleep mode, you can unlock the screen lock with the FeliCa card, cellular phone that supports FeliCa, smartphone and so on. For details, refer to the Help Guide.

## Wi-Fi connectivity

- The Wireless LAN functionality has passed Wi-Fi certification and complies with the interoperability specifications established by WFA (Wi-Fi Alliance).

## Wireless feature

- Turn off the wireless feature of the device when you are in a location where radio communications are prohibited. You must obtain permission from the appropriate authorities before enabling the wireless feature in such places.
- Turn off the wireless feature in health care facilities where any regulations posted in such areas instruct you to do so. Hospitals or health care facilities may be using equipment that could be affected by radio frequency (RF) energy which is generated by wireless communication.
- Do not use your device near medical equipment without first obtaining permission to do so.
- General notes on using the Wi-Fi (Wireless LAN) function. In some countries or regions, use of Wi-Fi products may be restricted by the local regulations (e.g. limited number of channels).
- Depending on the operating environment, unauthorized third parties on the network may be able to access the unit. When connecting the unit to the network, be sure to confirm that the network is protected securely.
- Communication content may be unknowingly intercepted by unauthorized third parties in the vicinity of the signals. When using wireless LAN communication, implement security measures properly to protect the communication content.

## Usage environment of NFC

If the device is placed on a metal desk, it may not function properly, such as failing to communicate with the FeliCa card or devices that support FeliCa. In this case, keep a few centimeters between the device and the metal desk.

## Applications on the device

Disclaimer: In no event will SONY be liable for any financial damage, or loss of profits, including claims made by third parties, arising out of the use of the software supplied with this device.

Sony is not responsible for incomplete recording/downloading or damaged data due to problems of the device or computer.

- Copyright laws prohibit reproducing the software or the manual accompanying it in whole or in part, or renting the software without the permission of the copyright holder.
- Due to continued efforts to improve quality, software specifications may be changed without notice.
- Operation of this device with software other than that provided is not covered by the warranty.
- Depending on the types of the text and characters, the text shown on the device may not be displayed properly. This is due to:
  - The capacity of the device.
  - The device is not functioning normally.
  - Content information is written in a language or character that is not supported by the device.
- We do not guarantee all languages will be able to be displayed properly on your device.
- User-created characters and some special characters may not be displayed.

## Touchscreen

- Do not press the screen or screen frame strongly or rub the screen. When operating the device, touch it softly.
- You can use the stylus while resting your hands on the touchscreen. When the stylus is near the touchscreen, the finger operation is inactive.

## RECYCLING LITHIUM-ION BATTERIES

For the customers in the USA and Canada

RECYCLING LITHIUM-ION BATTERIES

Lithium-Ion batteries are recyclable.

You can help preserve our environment by returning your used rechargeable batteries to the collection and recycling location nearest you.

For more information regarding recycling of rechargeable batteries, visit

[www.sony.com/electronics/eco/environmental-management](http://www.sony.com/electronics/eco/environmental-management)

Caution: Do not handle damaged or leaking Lithium-Ion batteries

## The device Disposal Reference

The built-in rechargeable battery of the device is recyclable. Do not remove the battery yourself; consult the Sony Support Center.

### For the customers in the U.S.A.

This equipment has been tested and found to comply with the limits for a Class B digital device, pursuant to part 15 of the FCC Rules. These limits are designed to provide reasonable protection against harmful interference in a residential installation. This equipment generates, uses and can radiate radio frequency energy and, if not installed and used in accordance with the instructions, may cause harmful interference to radio communications. However, there is no guarantee that interference will not occur in a particular installation. If this equipment does cause harmful interference to radio or television reception, which can be determined by turning the equipment off and on, the user is encouraged to try to correct the interference by one or more of the following measures:

- Reorient or relocate the receiving antenna.
- Increase the separation between the equipment and receiver.
- Connect the equipment into an outlet on a circuit different from that to which the receiver is connected.
- Consult the dealer or an experienced radio/TV technician for help.

This DPT-CP1 has been tested and meets the FCC RF exposure guidelines when used with the Sony Corporation accessories supplied or designated for this product. Use of other accessories may not ensure compliance with FCC RF exposure guidelines.

**Changes or modifications not expressly approved by the party responsible for compliance could void the user's authority to operate the equipment.**

If you have any questions about this product, you may call: Sony Customer Information Service Center 1-800-222-7669 or <http://www.sony.com/>

## Declaration of Conformity

Trade Name	: SONY
Model	: DPT-CP1
Responsible party	: Sony Electronics Inc.
Address	: 16535 Via Esprillo, San Diego, CA 92127 U.S.A.
Telephone Number	: 858-942-2230

**This device complies with part 15 of the FCC Rules. Operation is subject to the following two conditions: (1) This device may not cause harmful interference, and (2) this device must accept any interference received, including interference that may cause undesired operation.**

### FCC Radiation Exposure Statement

**The available scientific evidence does not show that any health problems are associated with using low power wireless devices. There is no proof, however, that these low power wireless devices are absolutely safe. Low power Wireless devices emit low levels of radio frequency energy (RF) in the microwave range while being used. Whereas high levels of RF can produce health effects (by heating tissue), exposure of low-level RF that does not produce heating effects causes no known adverse health effects. Many studies of low-level RF exposures have not found any biological effects. Some studies have suggested that some biological effects might occur, but such findings have not been confirmed by additional research. DPT-CP1 has been tested and found to comply with FCC radiation exposure limits set forth for an uncontrolled environment and meets the FCC radio frequency (RF) Exposure Guidelines.**

In order to comply with FCC radio-frequency radiation exposure guidelines for an uncontrolled exposure, **this device and its antenna must not be co-located or operating in conjunction with any other antenna or transmitter.**

### For the customers in the U.S.A.

**SONY LIMITED WARRANTY** - Please visit <http://www.sony.com/psa/warranty> for important information and complete terms and conditions of Sony's limited warranty applicable to this product.

### For the customers in Canada

**SONY LIMITED WARRANTY** - Please visit <http://www.sonybiz.ca/pro/lang/en/ca/article/resources-warranty> for important information and complete terms and conditions of Sony's limited warranty applicable to this product.

### For the customers in Europe

Sony Professional Solutions Europe - Standard Warranty and Exceptions on Standard Warranty. Please visit <http://www.pro.sony.eu/warranty> for important information and complete terms and conditions.

### For the customers in Korea

**SONY LIMITED WARRANTY** - Please visit <http://bpeng.sony.co.kr/handler/BPAS-Start> for important information and complete terms and conditions of Sony's limited warranty applicable to this product.

## No guarantee for data

Sony is not responsible for damaged (or deleted) data due to any problem with the device or computer.

### Notes

- Always make a test recording, and verify that it was recorded successfully.  
SONY WILL NOT BE LIABLE FOR DAMAGES OF ANY KIND INCLUDING, BUT NOT LIMITED TO, COMPENSATION OR REIMBURSEMENT ON ACCOUNT OF FAILURE OF THIS UNIT TO RECORD CONTENT OF ANY TYPE.
- Always verify that the unit is operating properly before use.  
SONY WILL NOT BE LIABLE FOR DAMAGES OF ANY KIND INCLUDING, BUT NOT LIMITED TO, COMPENSATION OR REIMBURSEMENT ON ACCOUNT OF THE LOSS OF PRESENT OR PROSPECTIVE PROFITS DUE TO FAILURE OF THIS UNIT, EITHER DURING THE WARRANTY PERIOD OR AFTER EXPIRATION OF THE WARRANTY, OR FOR ANY OTHER REASON WHATSOEVER.
- SONY WILL NOT BE LIABLE FOR CLAIMS OF ANY KIND MADE BY USERS OF THIS UNIT OR MADE BY THIRD PARTIES.
- SONY WILL NOT BE LIABLE FOR THE LOSS, REPAIR, OR REPRODUCTION OF ANY DATA RECORDED ON THE INTERNAL STORAGE SYSTEM.
- SONY WILL NOT BE LIABLE FOR THE TERMINATION OR DISCONTINUATION OF ANY SERVICES RELATED TO THIS UNIT THAT MAY RESULT DUE TO CIRCUMSTANCES OF ANY KIND.

## Backup

Sony recommends that you make a backup of the contents of the device in case of operation error or data corruption.

## Legal Notice

Copyright laws prohibit copying the data of this product or the contents of this manual (illustrations, related documents, etc.) in whole or in part without the permission of the copyright holder. Additionally, use of the data of this product or the contents of this manual is not allowed without Sony's permission except for personal use.

- Sony, the Sony logo are either trademarks or registered trademarks of Sony Corporation.
- Microsoft and Windows are trademarks or registered trademarks of Microsoft Corporation in the United States and / or other countries.
- Macintosh and Mac OS are trademarks of Apple Inc., registered in the U.S. and other countries.
- This DPT-CP1 contains Adobe Reader Mobile software under license from Adobe Systems Incorporated, Copyright © 1995-2011 Adobe Systems Incorporated. All rights reserved. Adobe and Reader are trademarks of Adobe Systems Incorporated.
- This product includes software developed by the OpenSSL Project for use in the OpenSSL Toolkit. (<http://www.openssl.org/>) Copyright © 1998-2011 The OpenSSL Project. All rights reserved.
- Wi-Fi, the Wi-Fi CERTIFIED logo, WPA, WPA2 and Wi-Fi Protected Setup are trademarks or registered trademarks of Wi-Fi Alliance.
- Foxit PDF SDK Copyright © 2013, Foxit Corporation [www.foxitsoftware.com](http://www.foxitsoftware.com), All rights reserved.
- Portions of this software are Copyright © 2005 The FreeType Project ([www.freetype.org](http://www.freetype.org)). All rights reserved.
- This software is based in part on the work of the Independent JPEG Group.
- The N-Mark is a trademark or registered trademark of NFC Forum, Inc. in the United States and in other countries.
- FeliCa is a trademark of Sony Corporation.

All other system names and product names appearing in this document are the registered trademarks or trademarks of their respective owners.

Further, the trademark™ and registered trademark® symbols are not indicated throughout this document.

## Specifications

### Model

DPT-CP1

### Basic information

Display	262 mm (10.3 in) diagonal electrophoretic display 1404 × 1872 pixel, 16-level gray scale
Touchscreen	Projected capacitive touchscreen capable of pen input
Internal memory capacity (for data storage)/User available capacity	16 GB/Approx. 11 GB
Interface	Micro USB connector

### Power source

Battery	Built-in rechargeable battery
Operating/Charging temperature	5 °C to 35 °C (41 °F to 95 °F)

### Dimensions/Mass

Dimensions (w/h/d)	Approx. 174.2 mm × 243.5 mm × 5.9 mm (6 7/8 in × 9 5/8 in × 1/4 in)
Mass (including battery)	Approx. 240 g (8.5 oz)

### Stylus

Battery	Built-in rechargeable battery
Operating/Charging temperature	5 °C to 35 °C (41 °F to 95 °F)

Design and specifications are subject to change without notice.

## Supported File Types

The following files can be transferred between the device and the computer. However, depending on the file size and format, it may not be possible to view some data. File extensions are shown in parentheses below.

## Documents

- PDF files (.pdf)\*

\* Compliant with PDF 1.7 specifications. The device does not support PDFs with extended features of Adobe extension level 1-8.