



OWNER'S MANUAL

Please read and understand all precautions prior to use.

Model / Modéle No.: G21H2RR (Remote), GF60609RR (Car)

Thank you for choosing a premium New Bright product.

USA & Canada
30-Day Limited Warranty

New Bright Industries warrants to the original purchaser that this product will be free of defects in materials and workmanship for thirty (30) days from the date of purchase. In the event of such defect within the warranty period, New Bright will repair or replace the product at our sole discretion. This warranty does not cover damage resulting from unauthorized modifications, accident, misuse, or abuse.

Should your item have a defect covered under this warranty, first call the toll free number listed below. Most problems can be resolved in this manner. If necessary, you will be issued a Return Authorization (RA) number and instructions on how to obtain a Product Return Form. The Product Return Form is to be used when returning a product to us (postage pre-paid and insured by the consumer).

When returning a defective product, please package the product, the Product Return Form and a copy of the dated sales receipt as proof of purchase. Be sure to mark the RA number on the Product Return Form. If the product is returned without a dated sales receipt, it will be excluded from coverage under this warranty. Please allow 4 to 6 weeks for delivery of repaired or replacement vehicles (depending on your location).

New Bright Industries' liability for defects in materials and workmanship under this warranty shall be limited to repair or replacement at our sole discretion. In no event shall we be responsible for incidental, consequential or contingent damages (except in those states that do not allow this exclusion or limitation).

Valid only in the USA & Canada.

Contact New Bright Industries Customer Service Toll Free at:
1-877-NBI-TOYS
(1-877-624-8697)
Monday through Friday, 8:00 AM to 5:00 PM Eastern Time

L575112846/JN120-16

COMPONENT CHECKLIST

- 1 R/C Vehicle
- 1 Controller
- 2 AA Batteries (located inside controller)
- 1 Rolling Cooler
- 3 Sticker Sheets

DEMO WIRE

This vehicle is shipped with a demo wire which runs from the transmitter to the vehicle chassis. The wire is for package demonstration only and should be removed and discarded. To remove wire, grasp firmly and pull.

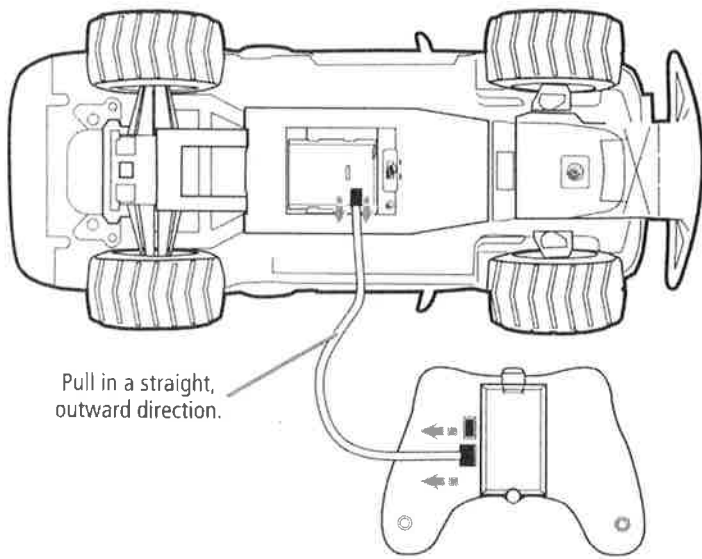

Remove and discard the demo wire which runs from the vehicle to the controller.

Battery Requirements (Included):

- Transmitter – 2 "AA" batteries
- Vehicle – 1 9.6V Internal Lithium-ion battery (non-replaceable)

TRANSMITTER BATTERIES

Batteries come pre-installed in this transmitter. To ensure the batteries remain fresh, there is a protective tab that must be removed prior to use.

1. Open battery compartment cover on transmitter by sliding it in the direction indicated by the arrow. Locate and remove protective plastic tab. The tab can be discarded.
2. To replace old batteries, open the compartment as described above.
Insert 2 "AA" size batteries. Make sure the positive (+) and negative (-) markings on the batteries match up to the ones inside the Battery Compartment.
3. Replace the Battery Compartment Cover making certain that the Compartment tab has "snapped" into the locked position.

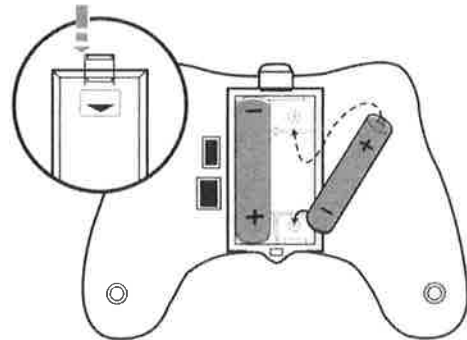

Note: When replacing Transmitter batteries:

- Do not mix old and new batteries.
- Do not mix alkaline, standard or rechargeable batteries.
- Use alkaline batteries only.

This transmitter is equipped with 2.4GHz technology which allows up to 6 vehicles to be used at the same time. To sync transmitter and vehicle, follow these steps:

1. Install batteries in Transmitter.
2. Turn on Vehicle.
3. Keep Transmitter in close proximity to vehicle.
4. The Transmitter will sync automatically with the Vehicle.

CHARGING THE VEHICLE BATTERY

This vehicle is equipped with an internal Lithium-Ion battery that is recharged via USB.

ON/OFF Switch must be in the OFF position prior to charging.

1. Locate the Charging Cord Compartment Cover on the underside of vehicle.
2. Remove USB cable from the Storage Compartment. (Use care when extending cord as it is attached to inside internal battery). Cord can be plugged into any computer or USB outlet brick (not included).
3. Insert the USB connector into a computer or other USB power source.
4. While charging, the Charging Status Light under the vehicle will be on. Once fully charged the light will turn off. Charging is completed in approximately 2-3 hours (when charging from a computer).
5. After charging is complete, store the USB cord in the Charging Cord Compartment. Replace the Compartment cover.

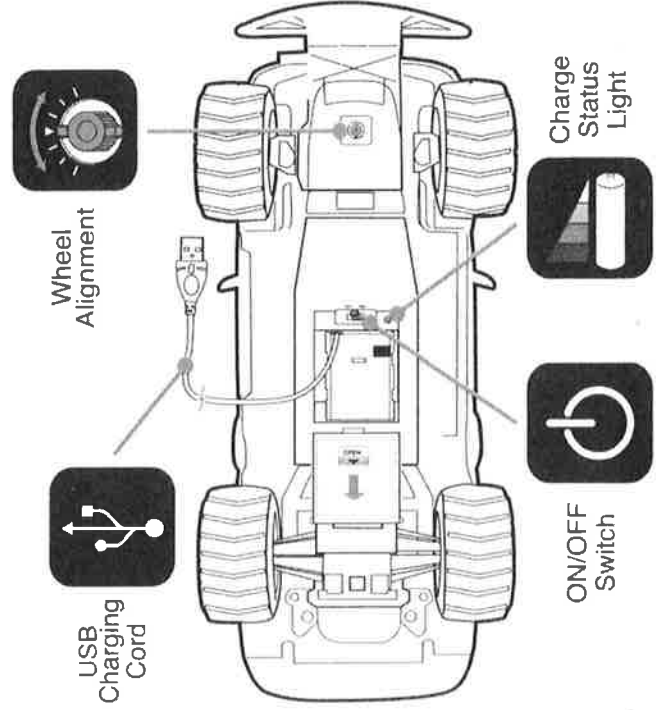

VEHICLE OPERATION

Features Operated by the controller:

DRIVING

- Move Left joystick up to move the vehicle FORWARD.
- Move Left joystick down to move the vehicle in REVERSE.
- Move Right joystick left or right to move vehicle LEFT or RIGHT.

This vehicle has working headlights.

- When driving forward or reverse the headlights will turn on.

This vehicle has sounds. In sound mode the sounds will continue until START/MUTE button is pressed or vehicle is turned off.

- Press HORN button on controller to hear horn sound.
- Press START/MUTE button on controller to hear engine sounds.
- Press START/MUTE button again to stop/mute sounds.

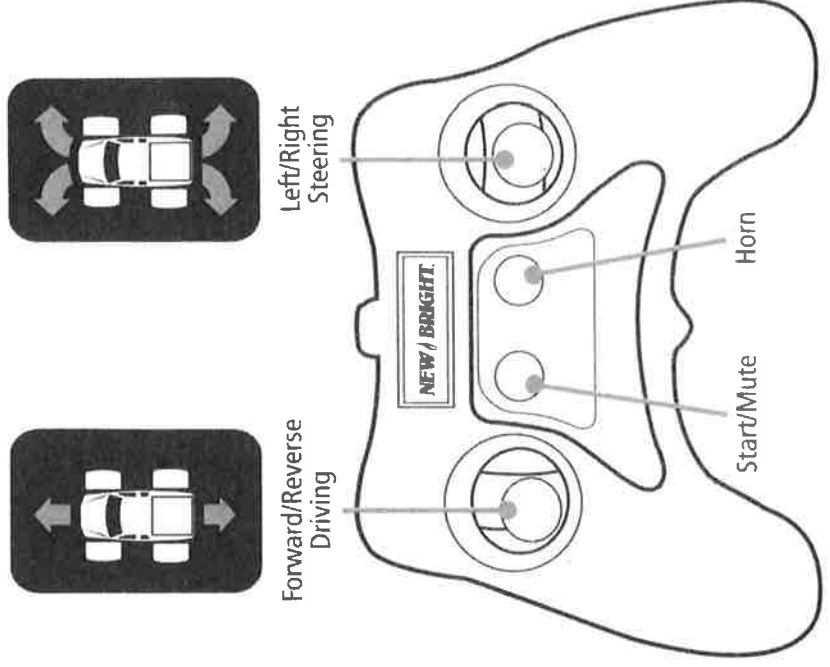

NOTE: This equipment has been tested and found to comply with the limits for a Class B digital device, pursuant to Part 15 of the FCC Rules. These limits are designed to provide reasonable protection against harmful interference in a residential installation. This equipment generates, uses and can radiate radio frequency energy and, if not installed and used in accordance with the instructions, may cause harmful interference to radio communications. However, there is no guarantee that interference will not occur in a particular installation. If this equipment does cause harmful interference to radio or television reception, which can be determined by turning the equipment off and on, the user is encouraged to try to correct the interference by one or more of the following measures:

- Reorient or relocate the receiving antenna.
- Increase the separation between the equipment and receiver.
- Connect the equipment into an outlet on a circuit different from that to which the receiver is connected.
- Consult the dealer or an experienced radio/TV technician for help.

FCC CAUTION:

Changes or modification not expressly approved by the party responsible for compliance could void the user's authority to operate the equipment.

FCC



JN332-03

RSS Statement

This device complies with Industry Canada licence-exempt RSS standard(s). Operation is subject to the following two conditions: (1) this device may not cause interference, and (2) this device must accept any interference, including interference that may cause undesired operation of the device.

Le présent appareil est conforme aux CNR d'Industrie Canada applicables aux appareils radio exempts de licence. L'exploitation est autorisée aux deux conditions suivantes : (1) l'appareil ne doit pas produire de brouillage, et (2) l'utilisateur de l'appareil doit accepter tout brouillage radioélectrique subi, même si le brouillage est susceptible d'en compromettre le fonctionnement.

PROPER USE

Precautions and Care



Wipe body with a soft rag or cloth.



Do not use chemicals or water to clean



Brush areas where dirt gets trapped.

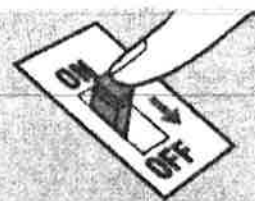

Switch vehicle OFF when not in use.



DO NOT LEAVE OUT IN THE SUN



DO NOT DRIVE ON SAND



DO NOT RUN INTO HARD OBJECTS



DO NOT USE ON LONG CARPET



DO NOT GET WET

CAUTION!

Do not recharge Battery Pack if it is hot or warm to the touch. Allow Battery Pack to cool before recharging. Recharging a hot or warm Battery Pack will shorten the life of the Pack.

Do not recharge a Battery Pack if it appears to be damaged or leaking.

Always unplug Adapter and Balance Charger when not in use.

Always remove Battery Pack from Battery Housing when not in use.

Do not dispose batteries in fire. Leakage, explosion and personal injury may occur.

Dispose of Lithium Ion Battery Pack properly.

Do not attempt to disassemble Adapter, Balance Charger or Battery Pack.

Do not use Adapter or Balance Charger for any use other than instructed in this booklet.

Only an adult should charge Batteries.

Do not attempt jumps or tricks with this vehicle.