

CAUTION-ELECTRICALLY OPERATED PRODUCT:
NOT RECOMMENDED FOR CHILDREN UNDER 8 YEARS OF AGE. AS WITH ALL ELECTRIC PRODUCTS, PRECAUTIONS SHOULD BE OBSERVED DURING HANDLING AND USE TO PREVENT ELECTRIC SHOCK.
INPUT: 120V AC 60Hz 10W. OUTPUT: 14.4V DC 500mA.



OWNER'S MANUAL

Please read and understand all precautions prior to use.

Model / Modèle No GFBLH01 (Remote), GFBLR01 (Car)

Thank you for choosing a premium New Bright product.

USA & Canada
30-Day Limited Warranty

New Bright Industries warrants to the original purchaser that this product will be free of defects in materials and workmanship for thirty (30) days from the date of purchase. In the event of such defect within the warranty period, New Bright will repair or replace the product at our sole discretion. This warranty does not cover damage resulting from unauthorized modifications, accident, misuse, or abuse.

Should your item have a defect covered under this warranty, first call the toll free number listed below. Most problems can be resolved in this manner. If necessary, you will be issued a Return Authorization (RA) number and instructions on how to obtain a Product Return Form. The Product Return Form is to be used when returning a product to us (postage pre-paid and insured by the consumer).

When returning a defective product, please package the product, the Product Return Form and a copy of the dated sales receipt as proof of purchase. Be sure to mark the RA number on the Product Return Form. If the product is returned without a dated sales receipt, it will be excluded from coverage under this warranty. Please allow 4 to 6 weeks for delivery of repaired or replacement vehicles (depending on your location).

New Bright Industries' liability for defects in materials and workmanship under this warranty shall be limited to repair or replacement at our sole discretion. In no event shall we be responsible for incidental, consequential or contingent damages (except in those states that do not allow this exclusion or limitation).

Valid only in the USA & Canada.

Contact New Bright Industries Customer Service Toll Free at:

1-877-NBI-TOYS

(1-877-624-8697)

Monday through Friday, 8:00 AM to 5:00 PM Eastern Time

L575112846/JN120-16

CONTENTS

Component Checklist

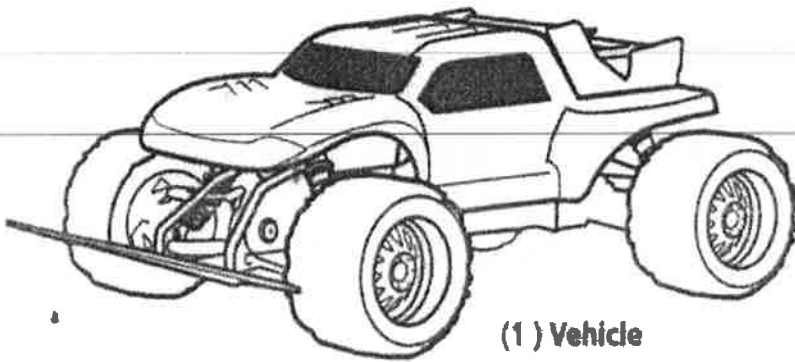

(1) Vehicle



(2) "AA" Batteries

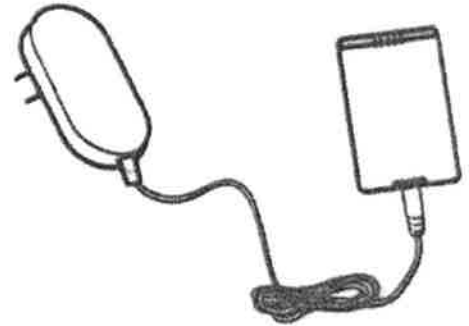

(1) Balance Charger
& (1) Adapter



(4) Extra Body Pins

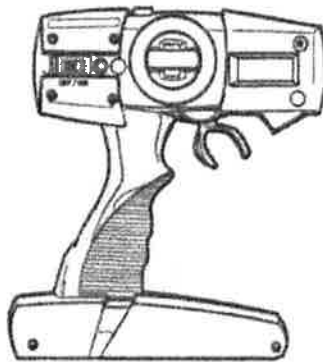

(1) 2.4GHz Transmitter

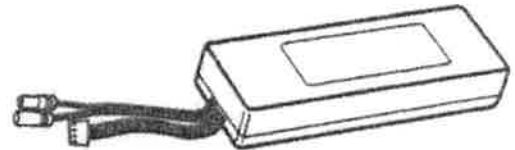

(1) 9.6V Lithium Battery

Body Shell Removal

Locate the 4 body pins on top of vehicle body.
Pull pins as shown and set aside.

Lift and remove body shell.

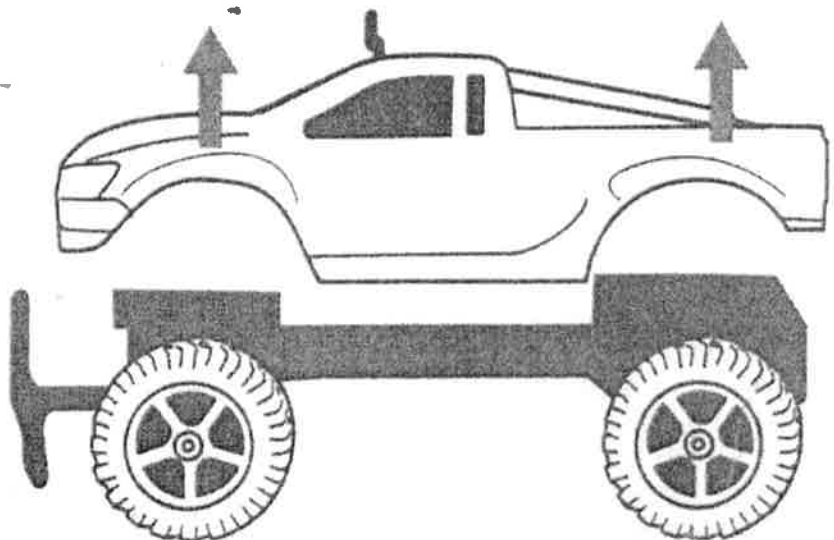
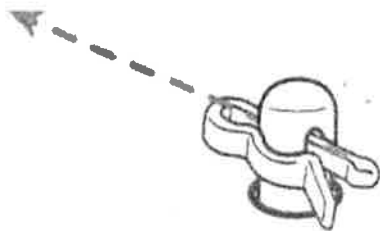

Features

Below is an illustration of the vehicle chassis with the body shell removed. Familiarize yourself with the features and functions of this vehicle.

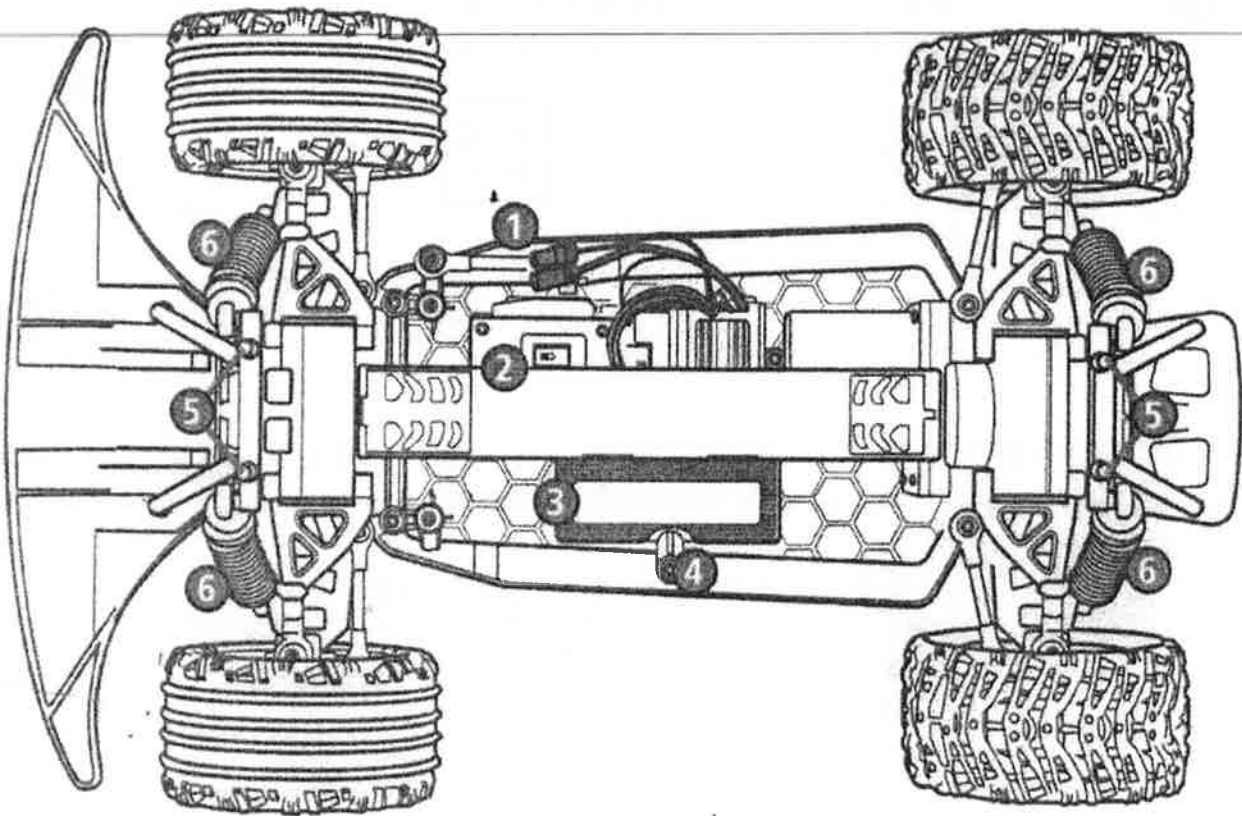

- ① Chassis Connectors
- ② ON/OFF Switch
- ③ Battery Housing
- ④ Battery Housing Lock
- ⑤ Body Support Posts
- ⑥ Adjustable Spring Suspension

To adjust the spring suspension, locate the 4 adjustable spring shocks above each wheel. Twist the top, threaded portion of the spring to tighten or loosen the suspension as shown below.



Tighten for Less Shock Absorption
For driving on a smooth and flat surfaces. Tighten the spring by twisting in a clock-wise motion.



Loosen for More Shock Absorption
For driving on a rough and bumpy surfaces. Loosen the spring by twisting in a counter clock-wise motion.

TRANSMITTER

Battery Installation

1. Locate the battery compartment on the underside of the transmitter.
2. Insert 2 "AA" size batteries. Make sure the positive (+) and negative (-) markings on the batteries match up to the ones inside the Battery Compartment.
3. Replace the Battery Compartment Cover making certain that the Compartment tab has "snapped" into the locked position.

Note: When replacing batteries:

Use alkaline batteries only.

Do not mix old and new batteries.

Do not mix alkaline, standard or rechargeable batteries.

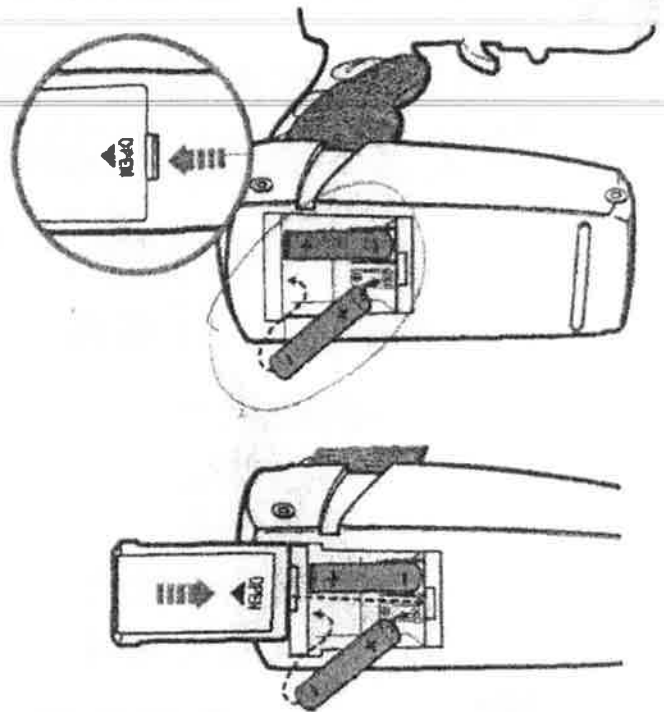

Functions

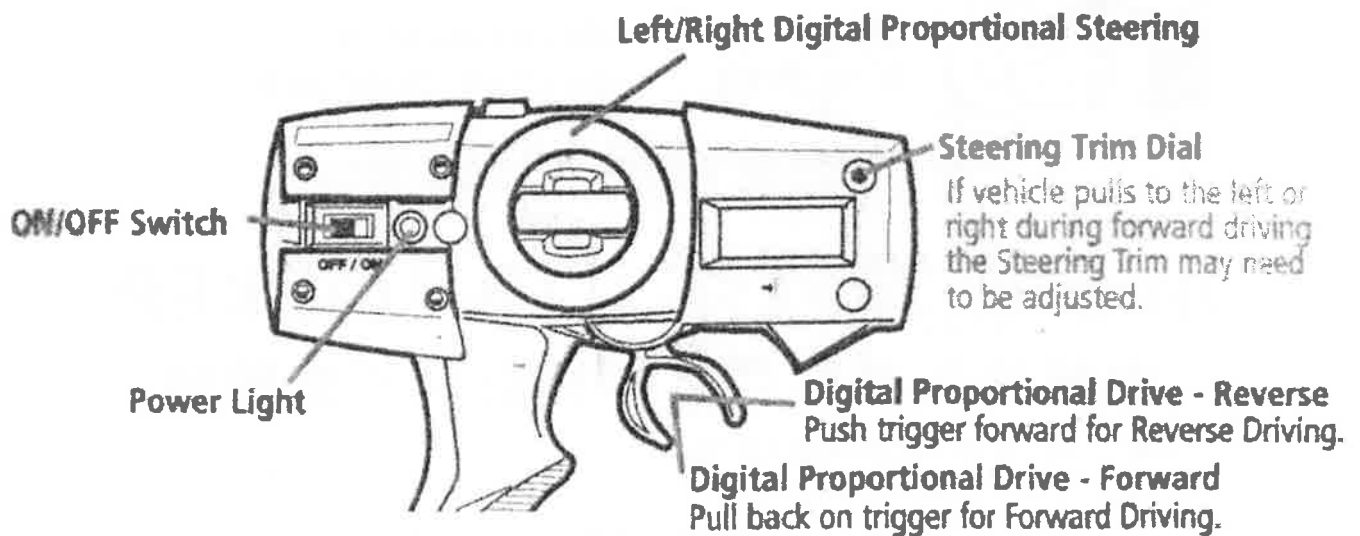

Syncing

This transmitter is equipped with 2.4GHz technology which allows up to 12 vehicles to be raced at the same time.

Once vehicle and transmitter batteries have been correctly installed and vehicle ON/OFF Switch is in the ON position, the transmitter will automatically sync with the vehicle.

BATTERY

Charging

IMPORTANT!

The included 9.6V Lithium battery pack is only **PARTIALLY CHARGED** prior to shipment and it is recommended the battery be fully charged before first use.

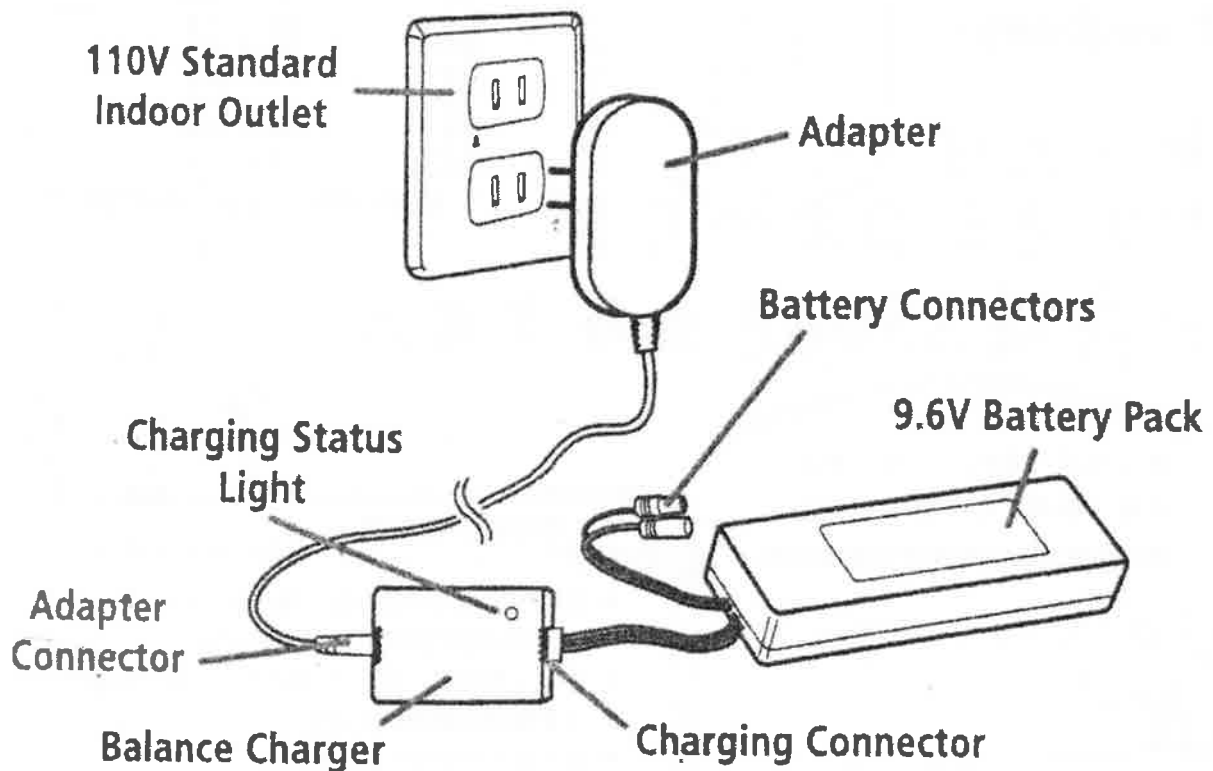

1. Connect the Adapter and Battery Pack to the Balance Charger as shown above.
2. Plug the Adapter into a standard indoor electrical outlet.
3. Allow battery to charge for 3-4 Hours. Charging Status Light will be solid red while battery is charging. When charging is complete, light will turn off. A blinking light indicates there is an error in charging the battery.
4. Charge will last approximately 15 minutes depending on terrain and driving style.

IMPORTANT: It is normal for the battery pack to become warm after charging and/or use. Be sure to allow the battery pack to cool before using or recharging. Recharging a warm battery pack will greatly reduce the battery life.

ATTENTION PARENTS:

- The Transformer, Balance Charger & Battery Pack need to be periodically examined for potential hazards. Any potentially hazardous parts need to be repaired or replaced.

Installing the Battery

1. Remove Body Shell as shown in Section 1.
2. Be certain the vehicle ON/OFF Switch is in the OFF position.
3. Locate the Battery Housing Lock and turn 90° to unlock.
4. Flip open the Battery Housing.

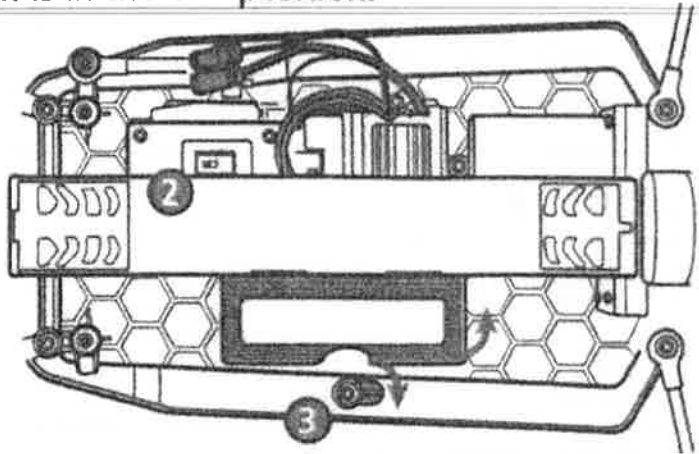
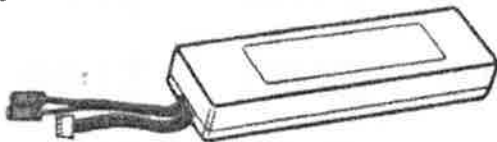

5. Position the Battery Pack within the Battery Housing with the connection wires pointing in the direction shown.
6. Close Battery Housing and turn the Battery Housing Lock to the locked position.
7. Thread Battery connection wires under chassis as shown to keep them protected.
8. Connect the Battery Connectors to the Chassis Connectors.

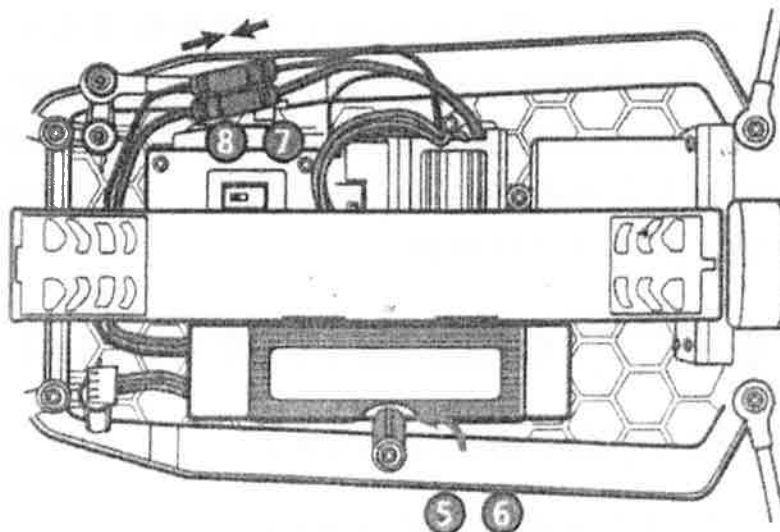

CAUTION:
When charging, disconnect the Battery Connectors from the Chassis Connectors.

9. Move vehicle ON/OFF switch to ON position.
10. Replace Body Shell and secure with pins.

NOTE: This equipment has been tested and found to comply with the limits for a Class B digital device, pursuant to Part 15 of the FCC Rules. These limits are designed to provide reasonable protection against harmful interference in a residential installation. This equipment generates, uses and can radiate radio frequency energy and, if not installed and used in accordance with the instructions, may cause harmful interference to radio communications. However, there is no guarantee that interference will not occur in a particular installation. If this equipment does cause harmful interference to radio or television reception, which can be determined by turning the equipment off and on, the user is encouraged to try to correct the interference by one or more of the following measures:

- Reorient or relocate the receiving antenna.
- Increase the separation between the equipment and receiver.
- Connect the equipment into an outlet on a circuit different from that to which the receiver is connected.
- Consult the dealer or an experienced radio/TV technician for help.

FCC CAUTION:

Changes or modification not expressly approved by the party responsible for compliance could void the user's authority to operate the equipment.

FCC



RSS Statement

This device complies with Industry Canada licence-exempt RSS standard(s). Operation is subject to the following two conditions: (1) this device may not cause interference, and (2) this device must accept any interference, including interference that may cause undesired operation of the device.

Le présent appareil est conforme aux CNR d'Industrie Canada applicables aux appareils radio exempts de licence. L'exploitation est autorisée aux deux conditions suivantes : (1) l'appareil ne doit pas produire de brouillage, et (2) l'utilisateur de l'appareil doit accepter tout brouillage radioélectrique subi, même si le brouillage est susceptible d'en compromettre le fonctionnement.

PROPER USE

Precautions and Care

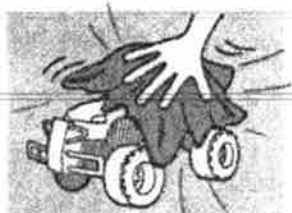

Wipe body with a soft rag or cloth.

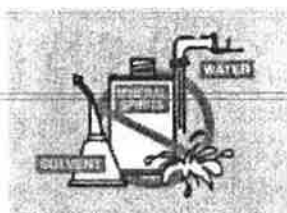

Do not use chemicals or water to clean

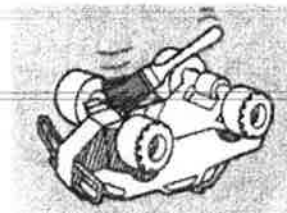

Brush areas where dirt gets trapped.

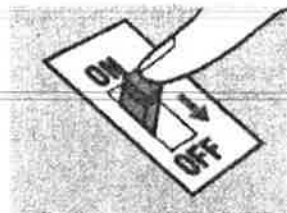

Switch vehicle OFF when not in use.



DO NOT LEAVE OUT IN THE SUN



DO NOT DRIVE ON SAND



DO NOT RUN INTO HARD OBJECTS



DO NOT USE ON LONG CARPET



DO NOT GET WET

CAUTION!

Do not recharge Battery Pack if it is hot or warm to the touch. Allow Battery Pack to cool before recharging. Recharging a hot or warm Battery Pack will shorten the life of the Pack.

Do not recharge a Battery Pack if it appears to be damaged or leaking.

Always unplug Adapter and Balance Charger when not in use.

Always remove Battery Pack from Battery Housing when not in use.

Do not dispose batteries in fire. Leakage, explosion and personal injury may occur.

Dispose of Lithium Ion Battery Pack properly.

Do not attempt to disassemble Adapter, Balance Charger or Battery Pack.

Do not use Adapter or Balance Charger for any use other than instructed in this booklet.

Only an adult should charge Batteries.

Do not attempt jumps or tricks with this vehicle.

SUPPORT

Trouble Shooting

Problem - Vehicle does not move or moves slowly.

- Has the Battery Pack been installed in the vehicle?
- Has the rechargeable Battery Pack been fully charged?
- Are the metal contact tabs touching, rusty or dirty in the connectors?
- Make certain there are fresh alkaline batteries in the transmitter and that they have been installed in the correct position.
- Are the (+) and (-) markings on the alkaline batteries in the same position as the (+) and (-) markings in the Transmitter Battery Compartment?
- Make certain that the vehicle ON/OFF switch is in the "ON" position.

Problem - Vehicle moves by itself or exhibits reduced range from the transmitter.

- Make certain there is no outside radio interference in your area. The best way to test this is to take the vehicle as far away from radio towers, electrical lines or tall buildings as possible to ensure no further radio interference will occur.

Proper Use

Precautions and Care



Switch vehicle OFF
when not in use.

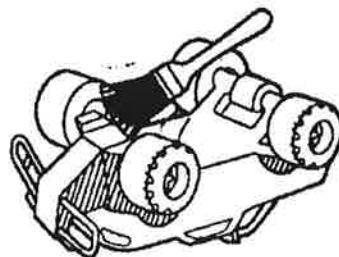

Brush areas where
dirt gets trapped.



Wipe body with a
soft rag or cloth.

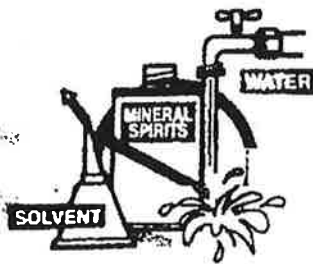

Do not use chemicals
or water to clean