

MODEL: PMP-3850

**2.4GHZ CORDLESS TELEPHONE
WITH CALL WAITING CALLER ID**

INSTALLATION AND OPERATING GUIDE

IMPORTANT: To receive Caller ID information on incoming telephone calls, you must subscribe to the Caller ID service provided by your local telephone company; there is a fee for this service and it may not be available in all areas.

PMP-3850 TABLE OF CONTENTS

Important Safety Instructions	2	Changing the Flash Time.....	25
FCC Regulations	3-4	Changing the Pause Time.....	26
Battery Cautionary Instructions	5	Programming One-Touch	
PMP-3850 Parts Checklist	6	Voice Mail Dialing.....	26
Location of Controls and Features ...7-11		Deleting Message Waiting	
Handset	7-8	Indication.....	27
Base	9-10	Speed Dialing	28-32
LCD Display	11	Storing Phone Numbers.....	28
Choosing a Location	12	Letter Table.....	29
Telephone Setup	13-15	Viewing the Phone Book.....	29
Connecting the Base	13	Making Calls From the Phone	
Wall Mounting	14	Book.....	30
Tone/Pulse Switch	15	Editing a Stored Number.....	30
Handset Volume	15	Deleting a Stored Number.....	31
Battery Installation	16	Deleting All Stored number	31
Battery Duration	16	Preferred Calls.....	32
When the Battery Needs Charging	16	Blocked Calls.....	32
When to Purchase a New		Caller ID	33-37
Battery Pack	16	When You Receive a Call	33
Headset and Data Jack	17	Viewing the Caller ID List	33
The Data Jack	17	Caller ID Displays	34
The Headset Jack.....	17	Caller ID with Call Waiting Service	35
Belt-Clip	17	Storing Caller ID Records	35
Basic Displays	18	Deleting Caller ID Records	36
Basic Operation	19-20	Returning Caller ID Calls	37
Making Calls	19	Message Waiting	38
Receiving Calls.....	19	Using One-Touch Voice Mail Dialing	38
Redialing	20	New Call Light	38
Additional Options	20	Other Features	39
Settings	21-27	Using the Handset Finder (PAGE)	39
Handset Settings.....	21-22	Out-of-Range Warning	39
Changing the Language.....	22	Channel Changing	39
Silent On or Off.....	23	Care and Maintenance	40
Setting the Time and Date.....	23	Troubleshooting	41
Setting the Ringer Level.....	24	Glossary	42
Adjusting the Contrast.....	24	Warranty	43-44
Setting the PBX Number.....	25	Wall Mount Template	45
		Battery Order Form	46

ORDER FORM

(This is your mailing label)

From:

TT SYSTEMS LLC
7 Odell Plaza
Yonkers, NY 10701

To order a replacement battery pack for the PMP-3850 cordless telephone, please mail this order form to the licensee for this product.

TT SYSTEMS LLC
7 Odell Plaza
Yonkers, NY 10701

Ni-MH Battery Packs are \$14.95 each

Please enclose a check or money order made out to **TT SYSTEM LLC** for the respective amount. Shipping and handling is included in the price.
Please ship order to:

To:

TT SYSTEMS LLC
7 Odell Plaza
Yonkers, NY 10701

Name: _____

Company: _____

Address: _____

City: _____ State: _____ Zip: _____

WALL MOUNT TEMPLATE

Place this template on the wall. The location of the screws is indicated by the centers of the crossed lines.

Fasten the screws leaving 3/16" of the screw extending from the wall.

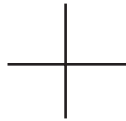

2 3/4"

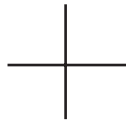

Remove This Page to Mark Wall

Screws needed for wall mounting:



Expansion Anchor



#6 or #8 Pan Head Self Tapping Screw

IMPORTANT SAFETY INSTRUCTIONS



This symbol is to alert you to important operating or servicing instructions that may appear in the user's manual. Always follow basic safety precautions when using this product to reduce the risk of injury, fire, or electrical shock.

When using this product, basic safety precautions should always be followed to reduce the risk of fire, electric shock and injury to persons, including the following:

1. Read and understand all instructions.
2. Follow all warnings and instructions marked on the product.
3. Use only with class 2 power source DC 9V 300mA.
4. Unplug this product from the wall outlet before cleaning. Do not use liquid cleaners or aerosol cleaners. Use a damp cloth for cleaning.
5. Do not use this product near water; for example, near a bathtub, wash bowl, kitchen sink or laundry tub, in a wet basement or near a swimming pool.
6. Do not place this product on an unstable cart, stand, or table. The product may fall, causing serious damage to the product.
7. Slots and openings in the cabinet back or bottom are provided for ventilation. To protect it from overheating, these openings must not be blocked or covered. The openings should never be blocked by placing the product on the bed, sofa, rug, or other similar surface. This product should never be placed near or over a radiator or heat register. This product should not be placed in an enclosed environment unless proper ventilation is provided.
8. Do not allow anything to rest on the power cord. Do not locate this product where the cord will be abused by animals or persons walking on it.
9. Do not overload wall outlets and extension cords as this can result in risk of fire or electrical shock.
10. Never push objects of any kind into this product through cabinet slots as they may touch dangerous voltage points or short out parts that could result in a risk of fire or electrical shock. Never spill liquid of any kind on the product.
11. To reduce the risk of electrical shock, do not disassemble this product. Instead take it to a qualified service person when service or repair work is required. Opening or removing covers may expose you to dangerous voltages or other risks. Incorrect reassembly can cause electrical shock when the appliance is subsequently used.
12. Unplug all cords and refer servicing to qualified service personnel under the following conditions:
 - A. When the power supply cord or plug is damaged or frayed.
 - B. If liquid has been spilled into the product.
 - C. If the product has been exposed to rain or water.
 - D. If the product does not operate normally by following the operating instructions. Adjust only those controls covered in the operating instructions. Improper adjustment of other controls may result in damage and require work by a qualified technician to restore the product to normal operation.
13. Avoid using a telephone (other than a cordless type) during an electrical storm. There may be a remote risk of electric shock from lightning.
14. Do not use a telephone to report a gas leak in the vicinity of the leak.

IF YOUR PRODUCT UTILIZES BATTERIES, THE FOLLOWING ADDITIONAL PRECAUTIONS SHOULD BE OBSERVED:

1. Use only the type and size of batteries specified in the users manual.
2. Do not dispose of batteries in a fire; the cells may explode. Check with local codes for possible special disposal locations.
3. Do not open or mutilate the batteries. Released electrolyte is corrosive and may cause damage to the eyes or skin. It may be toxic if swallowed.
4. Exercise care in handling batteries in order not to short the battery with conducting materials such as rings, bracelets and keys. The battery or conductor may overheat and cause burns.
5. Do not attempt to recharge the batteries with or identified for use with this product. The batteries may leak corrosive electrolyte or explode.
6. Do not attempt to rejuvenate the batteries provided with or identified for use with this product by heating them. Sudden release of the battery electrolyte may occur causing burns or irritation to eyes or skin.
7. When replacing batteries, all batteries should be replaced at the same time. Mixing fresh and discharged batteries could increase internal cell pressure and rupture the discharged batteries.
8. When inserting the batteries into this product, the proper polarity or direction must be observed. Reverse insertion of batteries can cause charging, which may result in leakage or explosion.
9. Remove the batteries from this product if the product will not be used for a long period of time (several months or more) since during this time the batteries could leak, damaging the product.
10. Discard "dead" batteries as soon as possible since they are more likely to leak in a product.
11. Do not store this product, or the batteries provided with or for identified use with this product, in high temperature areas.
12. If your product uses a rechargeable battery, charge the battery(ies) only in accordance with the instructions and limitation specified in the User Manual.

SAVE THESE INSTRUCTIONS

FCC REGULATIONS

Modifying or tampering with the telephone's internal components can cause a malfunction and might invalidate the telephone's warranty and void your FCC authorization to operate it. If the trouble is harming the telephone lines, the telephone company might ask you to disconnect the telephone until you have resolved the problem.

As it complies with Part 68 of the FCC rules, your unit has been registered with the FCC. The FCC requires us to provide you with the following information:

1. Connection and use with the nationwide telephone network:
The FCC requires that you connect to a nationwide telephone network through a modular telephone outlet which is Part 68 compliant.
This equipment may not be used on coin service provided by the telephone company.
Connection to party lines is subject to state tariffs. Check with your local telephone company.
2. Notification to the telephone company:
FCC rules require that upon request you provide the following information to the phone company.
 - A. The line (telephone number) to which you will connect the telephone equipment, and
 - B. The FCC Registration Number and Ringer Equivalence Number (REN). These numbers are found on the back or bottom of your telephone equipment.The REN is useful to determine the quantity of devices you may connect to your telephone line and still have all of those devices ring when your telephone number is called. In most, but not all areas, the sum of all RENs should be 5 or less. To determine the number of devices permitted in your area, contact your local telephone company.
3. Repair instructions:
If it is determined that your telephone equipment is malfunctioning, the FCC requires that it not be used and be unplugged from the modular outlet until the problem has been corrected. Repairs to this telephone equipment can be made only by the manufacturer or its authorized agents, or by others who may be authorized by the FCC. Unauthorized repairs void registration and warranty.
4. Rights of the telephone company:
If your product is causing harm to the telephone network, the telephone company may temporarily discontinue your service. If possible, they will notify you in advance. But if advance notice isn't practical, you will be notified as soon as possible. You will be given the opportunity to correct the problem, and you will be informed of your right to file a complaint with the FCC. Your telephone company may make changes in its facilities, equipment, operations or procedures that could affect the proper functioning of your telephone equipment. If such changes are planned, you will be notified in advance.
5. This product is compatible with inductively coupled hearing aids.
Note: This applies only if this product is equipped with a corded or cordless handset.
6. Programming/testing emergency numbers:
When programming emergency numbers and/or making test calls to emergency numbers
 - A. Remain on the line and briefly explain to the dispatcher the reason for the call before hanging up.
 - B. Perform such activities in the off-peak hours, such as early morning or late evening.

WARRANTY

- Some states do not allow limitations on how long an implied warranty lasts and/or do not allow the exclusions or limitations of incidental or consequential damages, so the above limitations or exclusions may not apply to you.
- TT Systems shall not be liable for any special or consequential damages or for loss or expense directly or indirectly arising from use of the products or in inability to use them either separately or in combination with other equipment or product accessories or from any other cause.
- TT Systems reserves the right to make changes in the design of the PMP-3850 and to make additions or improvements to the PMP-3850 without incurring any obligation to modify any PMP-3850 previously sold.

WARRANTY

TT Systems One Year Limited Warranty within the United States

1. What does the limited warranty cover?

TT Systems LLC warrants that the PMP-3850 sold by TT Systems within the continental limits of the United States, Hawaii and Alaska are free from defects in materials and workmanship under normal use for one year. This warranty is only applicable to the original purchaser of the PMP-3850, when accompanied by a sales receipt stating the date of the purchase and the name of the company from which it was purchased. This warranty is in lieu of and excludes all other warranties, expressed or implied, including any implied warranty of merchantability or fitness, and of any other obligation on the part of TT Systems.

2. What will TT Systems do when I send in my unit?

At our discretion, repair or replace the PMP-3850.

3. How do I send my unit, in or out of warranty?

- Properly pack your unit. Include any cables and accessories that were originally provided with the product. We recommend using the original carton and packing materials.
- Include in the package a copy of the sales receipt or other evidence of date of original purchase (if the unit was purchased within the last year).
- Print your name, address and phone number, along with a description of the problem, and include this in the package.
- Include payment for any service or repair not covered by the warranty, as determined by TT Systems. Contact a customer service representative at 1-800-592-1336 or tech@ttsystems.com to find out what payment is necessary.
- Ship the unit via UPS insured or equivalent to:

**TT Systems LLC
4 Executive Plaza
Yonkers NY 10701**

If you have not received your returned unit within 3-4 weeks, you may call 1-914-968-2100 regarding the status of your return.

4. What does not the warranty cover?

- Damage from misuse, neglect, or acts of nature (lightning, floods, power surges, etc).
- Products that may have been repaired or altered by persons not expressly approved by TT Systems.
- Products purchased outside the USA.
- Products purchased more than 12 months from the current date.
- Products which are not accompanied by a valid proof of purchase.

5. The legal information:

- There is no informal dispute settlement mechanism available.
- This warranty gives you specific legal rights, and you may also have other rights, which vary from state to state.

FCC REGULATIONS CONTINUED

INTERFERENCE INFORMATION: PART 15 OF FCC RULES

Some telephone equipment generates and uses radio frequency energy which if not properly installed, may cause interference to radio and television reception.

This unit has been tested and found to comply with the limits for a Class B computing device in accordance with the specifications in subpart J of Part 15 of the FCC rules. These specifications are designed to provide reasonable protection against such interference in a residential installation. However, there is no guarantee that interference will not occur in a particular installation.

If this equipment does cause interference to radio or television reception, when it's in use, the user is encouraged to try to correct the interference by one or more of the following measures:

- A. Where it can be done safely, reorient the radio or TV receiving antenna.
- B. To the extent possible, relocate the television, radio, or other receiver with respect to the telephone equipment.
- C. If your telephone product runs on AC power, plug your product into an AC outlet that's not on the same circuit as the one used by the radio or television.

BATTERY CAUTIONARY INSTRUCTIONS

BATTERIES: CAUTION

To reduce the risk of fire or injury to persons, read and follow these instructions:

For the cordless handset, use only a 3.6V600mAh GP60AAA3BX Nickel Metal Hydride (Ni-MH) cordless telephone battery pack (included).

Do not dispose of the batteries in a fire. The cells may explode. Check with local codes for possible special disposal instructions.

Do not open or mutilate the batteries. Released electrolyte is corrosive and may cause damage to the eyes or skin. It may be toxic if swallowed.

Exercise care in handling batteries in order not to short the battery with conducting materials such as rings, bracelets, and keys. The battery or conductor may overheat and cause burns.

Do not attempt to rejuvenate the batteries identified for use with this product by heating them. Sudden release of the battery electrolyte may occur causing burns or irritation to eyes or skin.

When inserting batteries into this product, the proper polarity or direction must be observed. Reverse insertion of batteries can cause charging, and that may result in leakage or explosion.

Remove the batteries from this product if the product will not be used for a long period of time (several months or more) since during this time the battery could leak in the product.

Do not store this product, or the batteries identified for use with this product, in high temperature areas. Batteries that are stored in a freezer or refrigerator for the purpose of extending shelf life should be protected from condensation during storage and defrosting.

Batteries should be stabilized at room temperature prior to use after cold storage.



The EPA certified RBRC® Battery Recycling Seal on the nickel-metal hydride (Ni-MH) battery indicates TT Systems LLC is voluntarily participating in an industry program to collect and recycle these batteries at the end of their useful life, when taken out of service in the United States or Canada. The RBRC® program provides a convenient alternative to placing used Ni-MH batteries into the trash or the municipal waste stream, which may be illegal in your area. Please call 1-800-8-BATTERY for information on Ni-MH battery recycling and disposal bans/restrictions in your area. TT Systems LLC's involvement in this program is part of our commitment to preserving our environment and conserving our natural resources.

GLOSSARY

Useful Features and Terms

PBX (Private Branch Exchange) -- A small, central, privately owned, switching telephone system where a digit (like 9) must be dialed first in order to access an outside line.

Calendar/Clock---- Visual display of date, day and time.

Caller ID-- Enables users to view name and number of callers. Contact your local telephone company to subscribe to Caller ID Service.

Caller ID Log--- Stores up to 80 Caller ID entries.

Call Timer--- Allows timing of phone conversations.

Data/FAX Port--- Allows connection of a PC or FAX machine directly into the phone versus a wall outlet.

Dial from Display One-button dialing from the Caller ID log.

Display The Liquid Crystal Display (LCD) shows clock and calendar, number dialed, low battery indicator, Caller ID information and call timer.

Flash A signal sent by the phone to the local telephone company supporting services such as call waiting.

Message Waiting Indicator --- A visual indicator that there are new messages in your voice mail box. Requires FSK signaling by phone company. Contact your local telephone company to subscribe to Voice Mail Service.

New Calls Indicator ---- A visual indicator that new calls have been received.

Redial --- Performs single button dialing of last number dialed.

Ring Lever Control --- Permits adjustment of the ring volume level.

Speed Dialing ---- Allows programming of frequently dialed numbers so that they can be dialed with the two touch speed dial button (40 entries).

Tone/Pulse Option--- Enables you to switch from pulse (rotary) to tone dialing.

Volume Level Control ---- Permits volume adjustment of the handset and headset during a conversation.

FSK type Signaling --- A signal used to turn on and off the message waiting indicator, can be sent by the telephone company with a ringing signal or without.

TROUBLESHOOTING

No dial tone/phone will not dial out.

- Check that the AC power adapter is plugged into a working AC power outlet.
- Check all telephone cord connections or try another wall jack.
- Do a basic reset of the phone: Disconnect the phone from the wall and remove the battery. Leave for 30 minutes and then re-install as instructed by the manual.

All the display segments stay on when the handset is in the base.

- Verify that the battery is properly installed.
- Remove the battery and clean the battery contacts using a pencil eraser.

Can't hear the ring signal.

- Check the ring volume controls; at the lowest level the ring may not be heard.

While on a call, you hear another call on the line or experience radio frequency interference.

- Switch channels to a clear channel.
- Check the wiring for bad connections.
- Do not use this phone within 20 feet of a working microwave. The microwave produces frequencies in this range which may cause interference. This interference is normal for all 2.4GHz phones and should not be considered a product defect.

The caller's name and/or phone number does not appear on the display.

- Make sure you have subscribed to Caller ID service (from local telephone company).
- Caller ID service may not work when the phone is connected to a Private Branch Exchange (PBX).
- The caller has requested that their phone number be suppressed from Caller ID service, or caller ID service is not available in their area. **"Private"** or **"Unavailable"** will appear on the display.
- You answered the call before Caller ID data was displayed, which usually occurs after the first ring.

New Call/Message Waiting Indicator doesn't work properly.

- Make sure you have subscribed to voice mail compatible with "FSK" type signaling (check with your local phone company). Verify that both the "On" and "Off" signals are activated. If your voice mail product from the local phone company does not support "FSK" signaling, you may use this feature as a New Call Indicator only.

Can't receive or make phone calls.

- Make sure the phone is set to the correct type of service, either Tone or Pulse.

PMP-3850 PARTS CHECKLIST



1. Handset

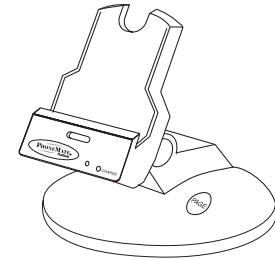

2. Base

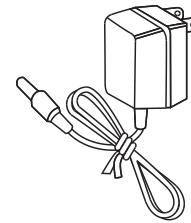

3. AC power adapter

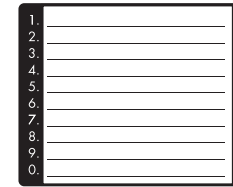

4. 10-number memory card



5. 5.7-foot line cord for desk use



6. Short line cord for wall installation

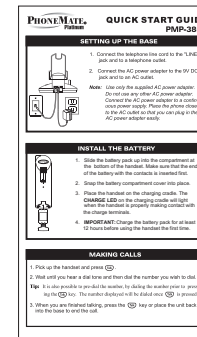

7. Quick start card



8. Belt-clip



9. Ni-MH battery pack

LOCATION OF CONTROLS AND FEATURES

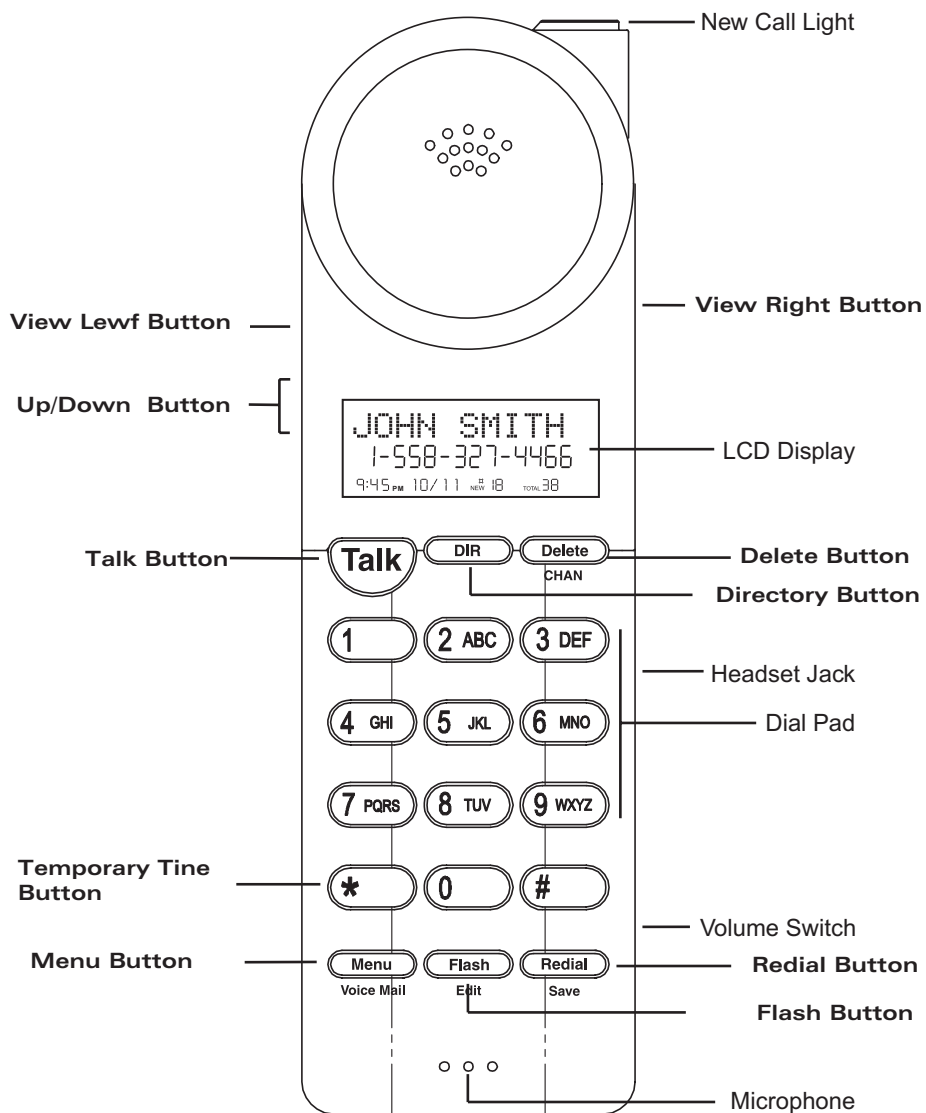

CARE AND MAINTENANCE

Your PMP-3850 telephone has been designed to give years of trouble-free service. It is a sensitive electronic instrument. To assure its longevity, please read the following maintenance instructions.

1. Keep the PMP-3850 away from heat as high temperatures can shorten the life of the electrical components and distort or melt its plastic parts.
2. The PMP-3850 should be kept free of dust and moisture. If it gets wet, wipe it dry immediately. Liquids can contain minerals that can corrode electronic circuits.
3. Handle your PMP-3850 gently and carefully. Dropping it can cause serious damage to circuitry, or the plastic case, which may result in malfunction.
4. Do not use any type of chemical or any abrasive powder to clean the cabinet. Use only mild detergents on a soft, damp cloth to clean the PMP-3850 telephone.
5. The PMP-3850 has built-in surge protection circuits that meet or exceed FCC requirements. However, an incident such as a lightning strike at or near the telephone lines, could cause serious damage.
6. If the PMP-3850 is installed in an area with frequent or severe electrical storms, it is suggested that the telephone be disconnected during these storms or that additional surge suppression equipment be added to the installation.
7. In the case of trouble with the telephone, do not attempt to repair the telephone yourself. It is the responsibility of users requiring service to report the need for service to our Service Department. They will make the necessary arrangements for repair or replacement.
8. If you should have any questions about the operation of your PMP-3850 telephone, please call our Service Department at **1-800-592-1336**. Or you may contact TT Systems LLC for technical assistance via our Internet Web site: www.ttsystems.com or e-mail: tech@ttsystems.com.
9. Please register your product online at www.ttsystems.com/CustomerSupport/RegOnline.asp

OTHER FEATURES

Using the Handset Finder (PAGE)

1. Press **PAGE** on the base and the phone will beep.



If the handset is within range, it will beep until a key is pressed.

2. Press any key on the handset, or place the handset in the base to stop the page/find feature.

Out-of-Range Warning

If you venture too far from the base, the handset will beep. Reverse your direction to re-establish connection with the base or the call will be dropped. When the base detects that the handset has been out of range for 20 continuous seconds it will release the engaged line.

Channel Changing

If you are experiencing interference during a telephone call, press the **Delete** /CHAN key. The PMP-3850 will scan up to 50 channels and select the clearest one to provide the best possible reception.

LOCATION OF CONTROLS AND FEATURES

Talk **Talk**

The **Talk** key is used to access the telephone line or end a call.

Directory Key **DIR**

Use **DIR** to program and retrieve the numbers in the speed dial directory.

Delete Key **Delete** /CHAN

When viewing or editing menus and logs, the **Delete** key is used to erase digits on the display, and single or multiple entries from the phone book and Caller ID directories. The **Delete** /CHAN key, when pressed while the phone is off-hook, will scan up to 40 channels and select the clearest one to provide the best possible reception.

Dial Pad

Numeric keys are used in the conventional manner for dialing.

Up/Down Key **▲▼**

The **▲▼** key let you scroll through menus and logs. Also used to access Caller ID information stored in memory.

Redial Key **Redial** /SAVE

When the phone is idle or off-hook, press **Redial** to redial the last number dialed. The **Redial** /SAVE key is used to save numbers into the phone book and other settings. It is also used to insert a programmable pause into a number stored in the phone book.

Flash Key **Flash** /EDIT

The **Flash** /EDIT key is used to access telephone company services, like call waiting. It is also used to create and edit phone book entries.

Menu Key **Menu** /VOICE MAIL

The **Menu** key is used to access the handset settings. The **Menu** /VOICE MAIL key can also be programmed to do one-touch dialing of a single number, such as your voice mail service number.

Temporary Tone Key *****

If the base is set to pulse dialing, pressing ***** causes subsequent digits to be dialed out using tone until the line is put back on hook.

View Left Key **◀** and View Right Key **▶**

Use **◀** to view the left part of the display and move the cursor left when editing. Use **▶** to view the right part of the display and move the cursor right when editing.

Headset Jack

Allows using a headset with a standard 2.5mm plug for hands-free convenience.

Volume Switch (Hi/MID/LOW)

Adjust the switch to select the receiver volume between HI, MID, and LOW.

LOCATION OF CONTROLS AND FEATURES

Base

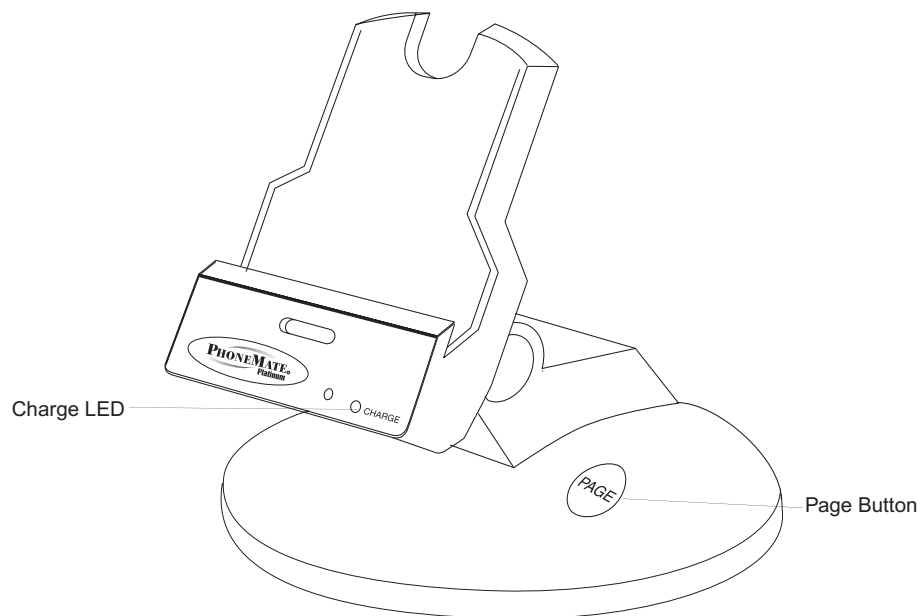

Page - Used to initiate a handset page .

Charge LED - Lights when the handset is on the cradle being charged. Lights when the handset is in use . Flashes when the phone is ringing.

MESSAGE WAITING

If you subscribe to voice mail from the telephone company and if there are voice messages that have been left in your voice mailbox, the display will show "MSG WAITING."



Note: This function requires voice mail subscription from the local telephone company. Furthermore, the local phone company must provide a type of voice mail signaling called "FSK " (Frequency Shift Key). Not all telephone companies have the visual message waiting feature available. Please contact your local telephone company to check if this is available in your area.

Tip: If you wish to delete the "Message Waiting" message, delete them as described in the handset settings section "Deleting the Message Waiting Indication" (see page 27).

Using the One-Touch Voice Mail Dialing

When the setting is programmed in the options menu (see "Programming One-Touch Voice Mail Dialing" on page 26) you can dial out a programmed number at the touch of a button. This feature is specifically designed to easily check voice mail when you have that service through your telephone company.

1. Press **(Talk)** to access the telephone line.
2. Press **(Menu)** /VOICE MAIL.
3. The phone will begin dialing the number.

New Call Light

When you receive a Caller ID message, voice mail message, or when the phone is ringing, the New Call light will flash accordingly.

- For Caller ID, the New Call light will flash to indicate that you have a new Caller ID call stored in memory.
- When you have a voice message waiting the New Call light will flash at a slow rate.

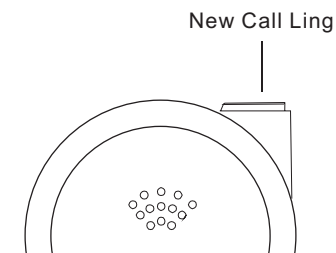

CALLER ID

Returning Caller ID Calls

You can return calls by using the Caller ID callback feature.

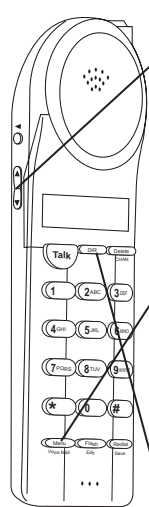
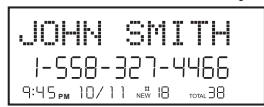
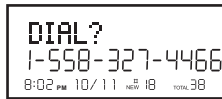
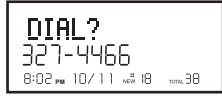
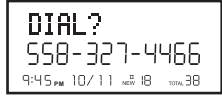
- 
1. Use the ▲▼ to scroll to the call record you wish to call back.

 2. If the number displayed is not correct (needing 7, 10, or 11 digits), use the **Menu** key to toggle the number to display the correct number of digits to be dialed.

Press **Menu**

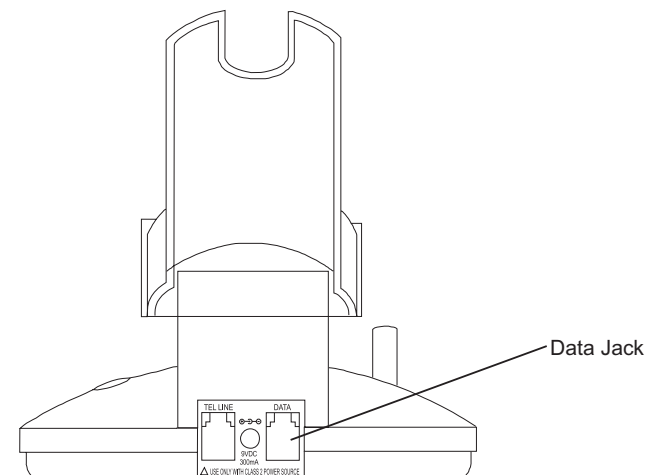
Press **Menu**

 3. Press **Talk** to dial out the displayed number.
 4. Press **DIR** to cancel dialing.
 5. To end the call, press **Talk**, or place the handset back in the base.

LOCATION OF CONTROLS AND FEATURES

Base Back View



Data jack

Used for connecting a computer or fax machine.

Base Bottom View

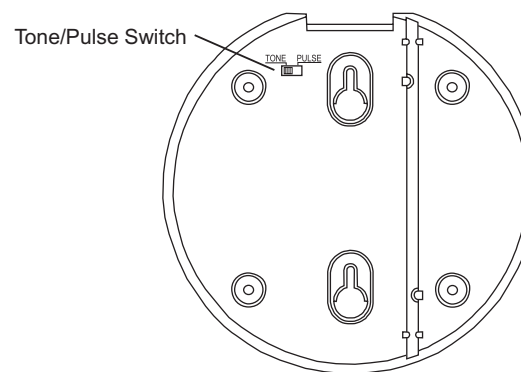

Tone/Pulse Switch

Used to set the dialing method for tone or pulse dialing.

LOCATION OF CONTROLS AND FEATURES

LCD Display

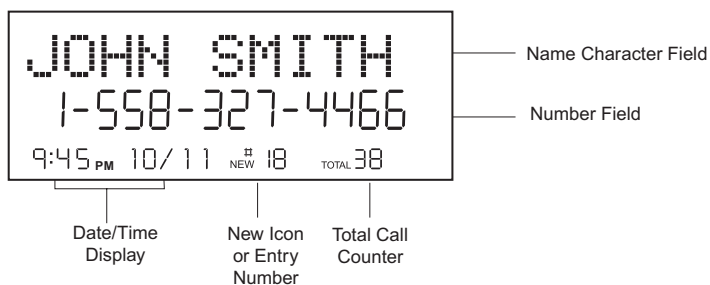

Name Character Field

Displays caller's name and operational menus.

Number Field

The number field will display numbers when dialing, viewing Caller ID, and when viewing the phonebook.

Date/Time Display

Shows the date and time of Caller ID calls or current date & time when idle.

NEW Icon

When in idle mode, the **NEW** call icon will flash slowly when a new Caller ID call has been received. The number of new caller ID calls is listed next to the icon.

Entry Number

When in any of the menus, a number is listed here. This number indicates the place in the list, such as the 18th caller ID entry.

RPT

When viewing caller ID entries, the **RPT** icon indicates that the same Caller ID number has called more than one time since Caller ID memory has last been reviewed.

Total Call Counter

The Total Call Counter will show the total number of Caller ID messages received, the total number of phone numbers stored in the phone book, etc., depending on the display mode.

CALLER ID

Deleting Caller ID Records

When viewing the Caller ID information you can delete a single call record or all the call records.

To Delete a Single Record

1. Use ▲▼ to scroll to the call record you wish to delete.

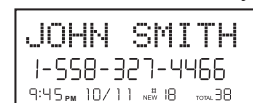
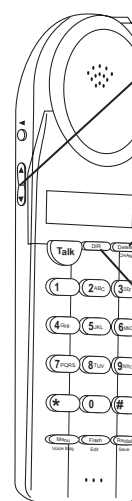

2. Press **Delete**.



3. To delete the record press **Delete**. The display will show next records.

4. Press **DIR** to exit the Caller ID log.

To Delete All Records

1. Press ▲ or ▼.

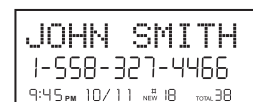
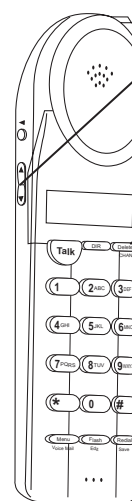

2. Press and hold **Delete**.



3. To delete all the Caller ID records press **Delete**. The display will show "NO DATA" and then return to the idle display.

CALLER ID

Caller ID with Call Waiting Service

In order to use the "Call Waiting Caller ID" service you must subscribe to a telephone company that offers Caller ID service combined with "call waiting" service.

When a new call comes in while you are talking, you will hear a notification beep from the handset and the volume is momentarily muted. The new caller's name and phone number, if available, appears on the display.

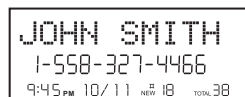

1. When you receive a "call waiting" call and you want to connect the call, press F. The active call will be placed on hold and the new call will be active.
2. Press F to alternate between calls.
3. Press T to end the call or place the handset back on the base.

Storing Caller ID Records

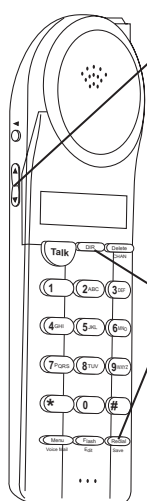

1. Use ▲▼ to scroll to the call record you wish to store into the phone book.
2. Press and hold **(Redial)** /SAVE.
3. If you wish to edit the newly stored number, edit it in the phone book (page 30, Editing a Stored Number).
4. Press **(DIR)** to return to the idle display.

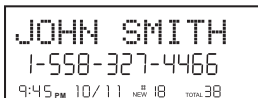

Note: When numbers are stored into the phone book, a 1 is inserted in front of the number. If you must dial a 10-digit number for local calls, you must edit the number to exclude that digit to dial out correctly.

CHOOSING A LOCATION

Do the following:

- Choose the best location
- Connect the phone
- Choose the dialing mode

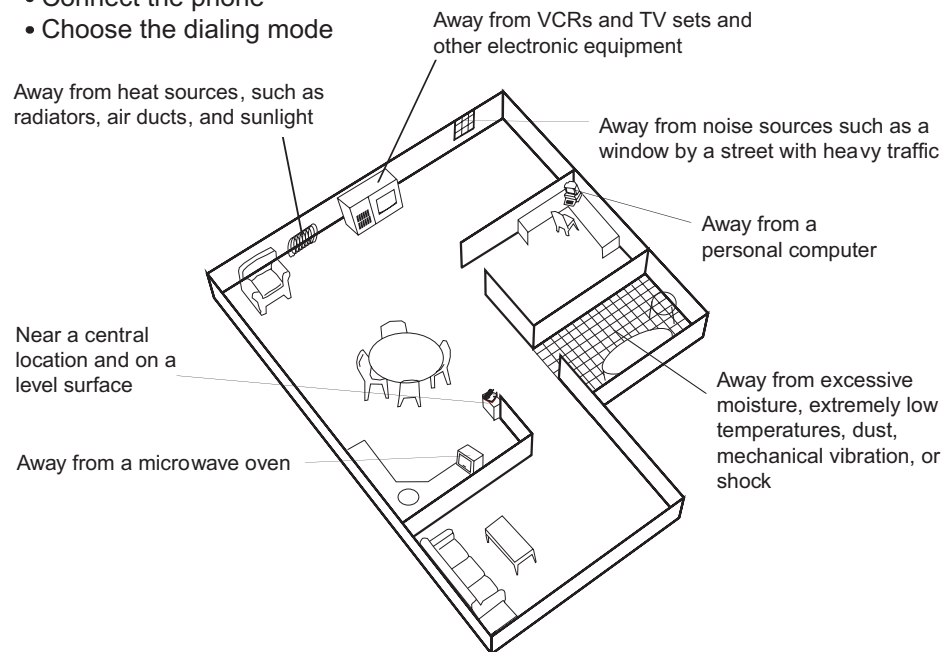

Where you place the phone affects the reception quality of the handset:

Away from another cordless telephone

Place the base near an AC electrical outlet and near telephone line jack

Place the base away from metal walls and metal file cabinets

CAUTION: The cordless telephone operates at a frequency that may cause interference to nearby TVs and VCRs; the base phone should not be placed near, or on top of a TV or VCR. If interference is experienced, moving the cordless telephone farther away from the TV or VCR will often reduce or eliminate the interference.

Note: While the 2.4GHz frequency is inherently clearer, we suggest that you do not use this phone within 20 feet of a working microwave. The microwave produces frequencies in this range which may cause interference. This interference is normal for all 2.4GHz phones and should not be considered a product defect.

TELEPHONE SETUP

Connecting the Base

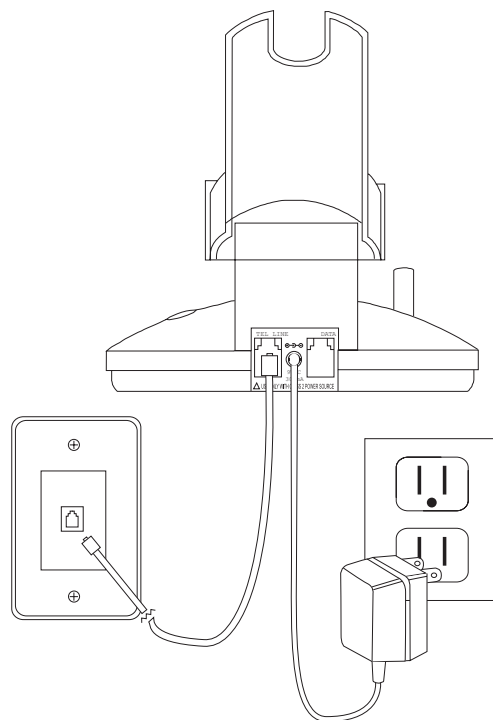

1. Connect the telephone line cord to the **"LINE"** jack and to a telephone outlet.
2. Connect the AC power adapter to the 9V DC jack and to an AC outlet.

Note: Use only the supplied AC power adapter. Do not use any other AC power adapter. Connect the AC power adapter to a continuous power supply. Place the phone close to the AC outlet so that you can plug in the AC power adapter easily.

Tip: If your telephone outlet is not modular, contact your telephone company for assistance.

CALLER ID

Caller ID Displays

JOHN SMITH
1-558-327-4466
9:45 PM 10/11 MON 18 100% 38

Display shows name and number, time and date of the call.

1-558-327-4466
9:45 PM 10/11 MON 18 100% 38

Display shows number-only service.

PRIVATE

10:34 AM 12/25 #40

"PRIVATE" will be shown when a call is received from a blocked number. For privacy reasons, some states allow callers the option to prevent their telephone data from being displayed on the other party's Caller ID display.

DATA ERROR

9:01 AM 12/25 #42 100% 38

Display shows when the Caller ID information was received incorrectly or only part of the data was received.

Note: When an error is received, none of the data from this call is saved in memory.

MSG WAITING

8:02 AM 12/25 #40 100% 39

Display shows when a voice mail message has been received and is stored by message waiting service provided by the phone company.

NO DATA

9:01 AM 12/25 #40 100% 38

This is displayed when ▲ or ▼ is pressed and there is no Caller ID data stored.

CALLER ID

Caller ID allows the caller's name and phone number to be shown on the display before you answer the call. In order to use this feature you must first subscribe to Caller ID service with your telephone company.

When You Receive a Call

1. When the telephone rings, the caller's name and phone number appears on the display.
2. The new Caller ID record includes the name and number of the caller and the time and date the record is received. The New Call light will flash to indicate that you have a new Caller ID call stored in memory.

Note: When the Caller ID information is received, it is stored in memory so that this information can be recalled for later use. Up to 80 Caller ID calls can be stored.



JOHN SMITH
1-558-327-4466
9:45 PM 10/11 NEW 18 TOTAL 38

Viewing the Caller ID List

This phone automatically stores the last 80 calls received. If a call is received from the same number more than once since the records were last viewed, no new entry is made, but the repeat call icon ("RPT") is displayed.

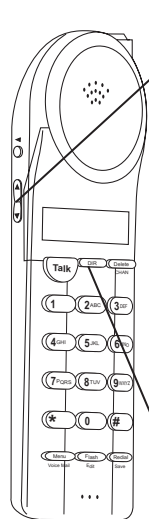

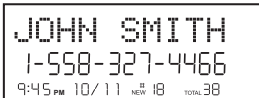
1. With the handset idle press ▲ or ▼ .
 2. Any unviewed (new) calls will be displayed first. The most recent call will be displayed. The information on the call will be displayed with the name, number, date, and time that the call was received.
- 
- JOHN SMITH
1-558-327-4466
9:45 PM 10/11 NEW 18 TOTAL 38
3. To scroll to the next call, press ▲ or ▼ . The ▼ will go through the calls from the last call received to the first. The ▲ will allow you to view the calls from the first call received to the last.
 4. If the name or number is more than 11 characters, press the ► or ◀ button to view the rest of the display (as indicated by the arrows in the top line of the display).

5. Press **DIR** to return to the idle display.

TELEPHONE SETUP

Wall Mounting

The PMP-3850 telephone may be installed onto two screws (not included) fastened into the wall. When installing screws into plasterboard walls, use wall anchors (not included) to ensure that the screws remain secure. Insert the screws into the wall leaving 3/16" of each screw extending out from the wall. See the wall mount template on page 45 to properly space the screws in the wall for mounting. The PMP-3850 is not compatible with mounting on a standard telephone wall plate.

Wall Mounting Instructions:

1. Remove the handset from the base.
2. Turn the base over so the underside of the base faces you.
3. Adjust the base to the wall mount position.
4. Plug the supplied 7-foot telephone cord into the **LINE** jack on the telephone.
5. Connect the telephone line cord to the wall jack.
6. Insert the AC adapter into the **9V DC** jack on the top of the base .
7. Run the cables down through the cable channel to allow for flush wall mounting.
8. Slip the telephone base onto the wall, lining up the wall mounting holes over the screws. Slide the telephone base down so it is firmly in place.
9. Return the handset to the telephone base .
10. Plug the other end of the AC adapter into the AC outlet.

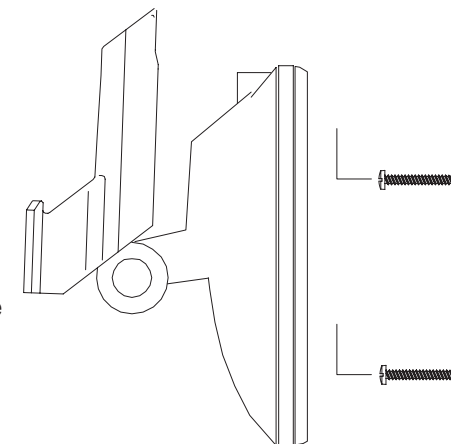

TELEPHONE SETUP

Tone/Pulse Switch

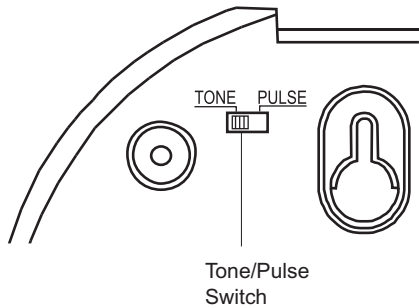

1. Choose the correct dialing mode.
2. Select the dialing mode Tone or Pulse by setting the switch on the bottom of the base unit.

Note: Changes to the switch position during a call do not take effect until the call has ended.

Tip: If you are unsure of the proper dialing mode, make a trial call with the dial mode setting to **TONE**. If the call connects, leave the switch as is (**TONE** mode), otherwise, set to **PULSE**.

NOTE: Pulse dialing works for direct dialing and redialing only, not for memory dialing.

Handset Volume

Adjust the receiver volume of the handset using the volume control switch on the right side of the handset.

Note: Ringer options can be selected on the handset when programming setup functions (see page 22).

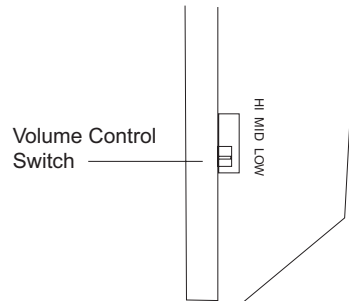

SPEED DIALING

Preferred Calls

You can assign stored numbers as preferred calls. When an incoming call is matched to a stored number designated as preferred, the phone will generate a special ring sound after caller ID information is received. To mark a phone book entry as preferred, add a "#" mark at the beginning of the name during programming or editing.

#JOHN SMITH 1-558-327-4466 <small>8:02" 12/25 #5 vsm JS</small>

Blocked Calls

If you do not want to have the phone ring when a specific number calls, you can store that number in the phone book and assigned it as blocked. When an incoming call is matched to a stored number designated as blocked, the phone will not ring after caller ID information is received. To mark a phone book entry as blocked add a "*" mark at the beginning of the name during programming or editing.

*JOHN SMITH 1-558-327-4466 <small>8:02" 12/25 #5 vsm JS</small>

SPEED DIALING

Deleting a Stored Number

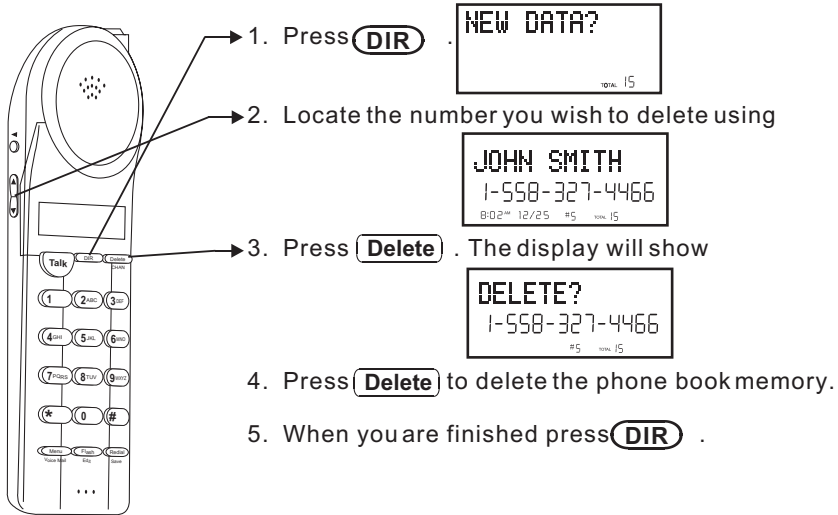

Deleting All Stored number

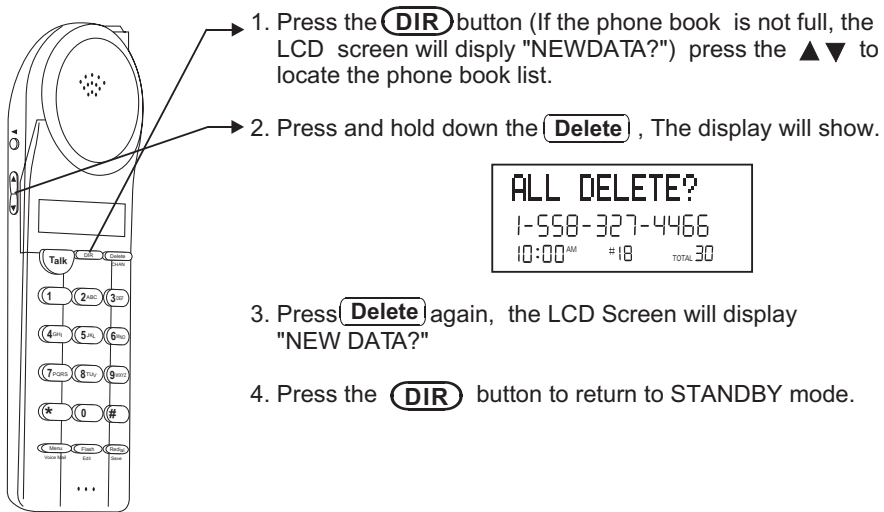

TELEPHONE SETUP

To install the cordless Ni-MH handset battery pack:

- Slide the battery pack up into the compartment at the bottom of the handset. Make sure that the end of the battery with the contacts is inserted first.
- Snap the battery compartment cover into place.
- Place the handset on the charging cradle.
- Once you have installed the battery pack and placed the handset on the cradle you will hear a tone indicating the handset has connected with the charging contacts and will successfully charge.
- IMPORTANT:** Charge the battery pack for at least 12 hours before using the handset the first time.
- The **IN USE/CHARGE** LED on the charging cradle will light when the handset is properly making contact with the charge terminals.

Battery Duration

A fully charged battery lasts for approximately:
 4 hours when you use the handset continuously (talk time).
 5 days when the handset is not in use (standby).

When the Battery Needs Charging

The phone will beep.
 The display will show the Low Battery icon.



When to Purchase a New Battery Pack

If the battery lasts only a few minutes even after a full charge, the usable life of the battery has expired and needs to be replaced. Replacement batteries can be purchased directly from <https://www.ttscsystems.com/ShoppingCart/shoponline2.asp>, or you can contact TT Systems LLC customer support center at 1-800-592-1336 for information about how to order a new battery.

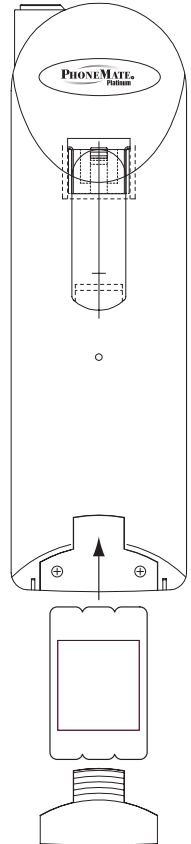

HEADSET AND DATA JACK

The Data Jack

The jack located on the side of the telephone labeled "DATA" is a convenience jack. It is useful for connecting a fax machine or modem when there is no telephone jack available for that device.

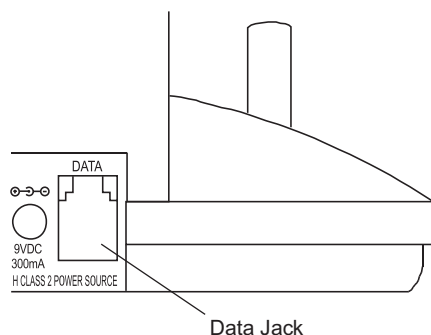

Data Jack

The Headset Jack

The headset jack is located on the side of the handset and is a standard 2.5mm plug. Simply plug the headset (not included) into the jack and the headset will be active.

Note: When the headset is plugged into the telephone, the microphone and earpiece on the handset are not active.

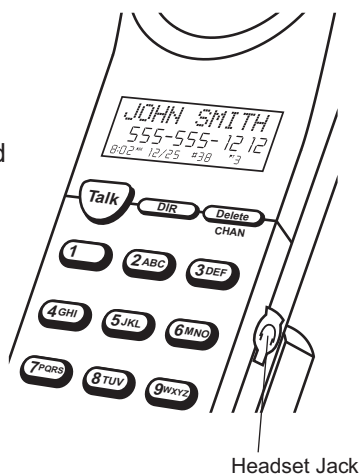

Headset Jack

Belt-Clip

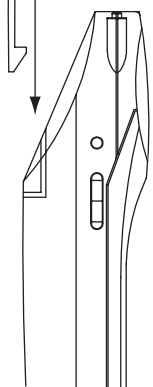

Belt-Clip

Be sure to remove the belt-clip filler cap prior to installing the belt-clip. Install the belt-clip as shown.

To remove the belt-clip, squeeze the release at the top of the clip where it attaches to the phone, and gently pull the clip up and out of the handset.

SPEED DIALING

Making Calls From the Phone Book

- To make a call from the phone book, press **DIR**.
- Use **▲▼** to locate the exact number you wish to dial.
- Push **Talk**. The display will show the directory name, and begin dialing the number.
- When you are finished with your call, press **Talk**, or place the handset back on the base.

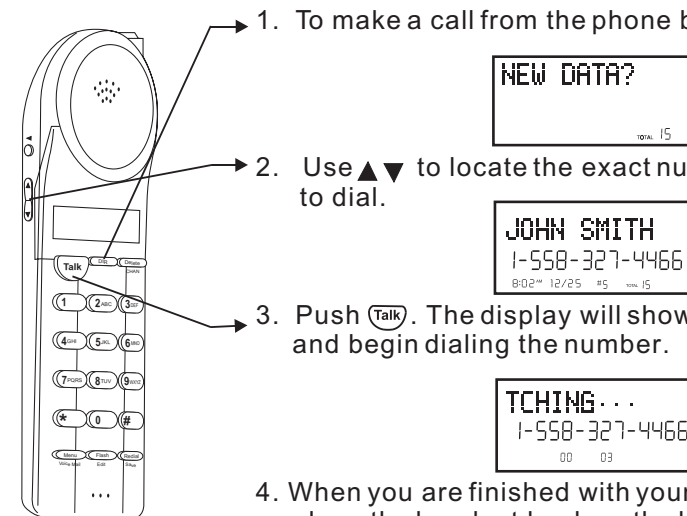

Editing a Stored Number

- Press **DIR**.
- Locate the number you wish to edit.
- Press **Flash** /EDIT. The entry will display with a flashing prompt over the first character.
- Move the cursor to the section you wish to edit using the **▲▼, ◀▶** keys. Characters or numbers will be inserted in front of the cursor.
- To erase a character or digit, press the **Delete** key.
- When the entry is edited as you desire press and hold **Redial** /SAVE to store the edited entry.

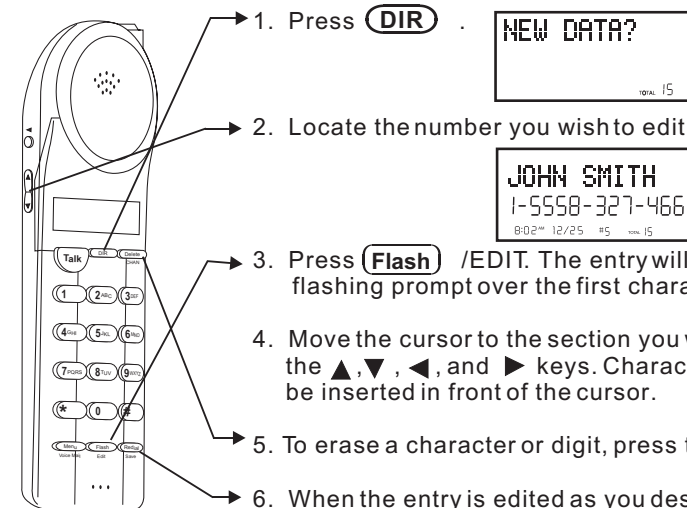

SPEED DIALING

Letter Table

Key	1th Press	2th Press	3th Press	4th Press	5th Press	6th Press	7th Press	8th Press	9th Press
1	Space	1	&	'	()	.	Space	1
2	A	B	C	a	b	c	2	A	B
3	D	E	F	d	e	f	3	D	E
4	G	H	I	g	h	i	4	G	G
5	J	K	L	j	k	l	5	J	K
6	M	N	O	m	n	o	6	M	N
7	P	Q	R	S	p	q	r	s	7
8	T	U	V	t	u	v	8	T	U
9	W	X	Y	Z	w	x	y	z	9
0	0	0	0	0	0	0	0	0	0

Viewing the Phone Book

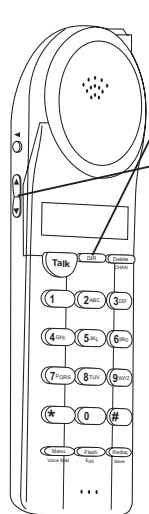

1. Press **DIR** to enter the phone book.

```
NEW DATA?
TOTAL 15
```

2. Use ▲▼ to locate the exact number you wish to view.

```
JOHN SMITH
1-558-327-4466
8:02 AM 12/25 #5 TOTAL 15
```

3. If the name or number is more than 11 characters, press the ► or ◀ button to view the rest of the display (as indicated by the arrows in the top line of the display).

```
JOHN SMITH
1-558-327-4466
8:02 AM 12/25 #5 TOTAL 15
```

4. Press **DIR** to exit the phone book, or let the phone book time out.

BASIC DISPLAYS

Handset Idle (after time is set)

```
10:02 AM 10/11 NEW 0 TOTAL 11
```

New CID Received

```
NEW CALL: 03
10:11 AM 10/12 NEW 3 TOTAL 39
```

Line Ringing

```
RING
9:45 AM 10/11 NEW 0 TOTAL 11
```

Message Waiting

```
MSG WAITING
8:02 AM 12/25 NEW 0 TOTAL 39
```

Off-hook

```
CALLS
TALKING...
9:45 AM 10/11 0 21
```

Call Timer

```
CALLS
1-558-327-4466
10:45 AM 10/11 1 14
```

BASIC OPERATION

Making Calls

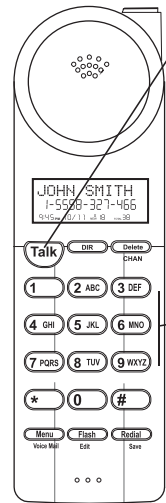

1. Pick up the handset and press **Talk**.

WAITING
9:45 PM 10/11 NEW 18 TOTAL 38

TALKING...
9:45 AM 10/11 0 21

2. Wait until you hear a dial tone and then dial the number you wish to dial. The call timer will begin.

Tip: It is also possible to pre-dial the number, by dialing the number prior to pressing the **Talk** key. The number displayed will be dialed once **Talk** is pressed.

3. When you are finished talking, press the **Talk** key or place the unit back into the base to end the call.

Receiving Calls

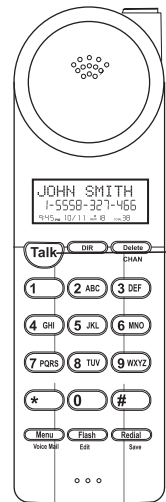

When you hear the phone ring:

1. The display will show "RING". If you have Caller ID, the display will show the Caller ID information after the first ring.

RING
9:45 AM 10/11 NEW 0 TOTAL 11

2. With the handset off the base, push **Talk**. The call timer will start.

3. When you are finished, push **Talk** or place the handset back on the base.

SPEED DIALING

The PMP-3850 will store up to 64 speed dial numbers in alphabetical order. No duplicate numbers can be stored.

Storing Phone Numbers

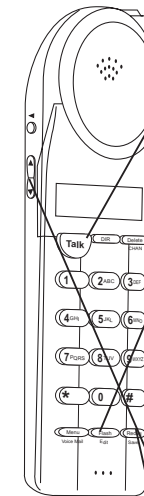

1. With the handset in the idle state, press **Talk**.

NEW DATA?
TOTAL 15

2. Press **Flash** /EDIT to create a new phone book entry.

JOHN SM
8:02 AM 12/25 NEW 0 TOTAL 15

3. Enter the name you wish to store using the dial pad to enter the letters (up to 16 letters). See the following letter table for how to program the letters using the number pad. To move the cursor to the right, such as to enter a new letter, push **▶**.

Example: For **JOHN SMITH** dial this sequence:

5	666	44	66	1	7	6	444	8	44
J	0	H	N	space	S	M	I	T	H

4. Press **▼**, and dial the number you wish to store (up to 16 digits). Press **Redial** to insert a dialing pause into the number.

JOHN SMITH
18885
8:02 AM 12/25 NEW 0 TOTAL 15

5. Press and hold **Redial** /SAVE when finished to store the number into memory.

Note: If you mis-type entering the phone number, you can move through the number and edit it by pressing **◀** or **▶**. To delete a character or number inside the cursor, press the **Delete** key.

SETTINGS

Deleting Message Waiting Indication

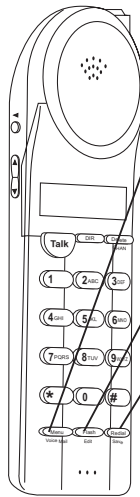

1. Press and hold the **(Menu)** key to enter the menu.
2. Press **0** to go to the message waiting programming option.
3. Press **(Flash)** /EDIT to reset the message waiting indication.
4. Press and hold **(Redial)** /SAVE to delete the indication. A long beep will sound to confirm.
5. Continue with programming or press **(Menu)** to return to the idle screen.

BASIC OPERATION

Redialing

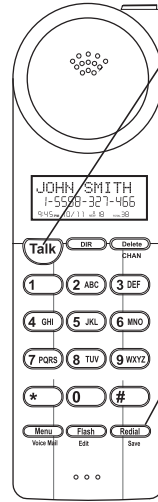

1. press **(Talk)** .



2. Wait until you hear the dial tone and then press **(Redial)** to redial the number last dialed .

Additional Options

To:	Do This:
Adjust the volume in the earpiece	Adjust the volume control switch on the right side of the handset to the desired volume level.
Switch to temporary tone dialing	Press the (*) key after the phone is in use. The phone will remain in tone dialing mode for the duration of the call.
Receive a call waiting call	Press (Flash) to go to the new caller. Press (Flash) again to go back to the original caller.

SETTINGS

Handset Settings

You can change the setting on the handset in the options menu. Access the options menu by pressing and holding the **(Menu)** key.

There are 10 settings in the options menu which can be changed. You can scroll through the option menu in the listed order by pressing the **▲▼** key. Settings can be reached directly by pressing that number on the keypad.

To edit a setting, press the **(Flash)** /EDIT key, use the **▲▼** key to toggle between the setting options, and then press and hold **(Redial)** /SAVE to save changes. You can continue programming options by using the dial pad keys or the **▲▼** key to go to a new setting. Press **(Menu)** to exit the options menu.

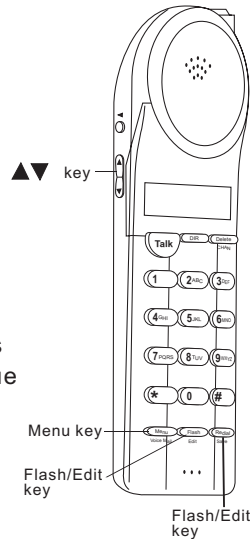

Key Function

- 1 **Language:** Change the language that appears on the display. Choose between English, French, and Spanish.
- 2 **Silent On/Off:** Turn the first ring of the phone off so that it does not ring until caller ID information has been displayed. Particularly useful when using the priority and blocked call features or the private and unavailable ring settings.
- 3 **Time Set:** Change the time and date.
- 4 **Ring Hi/Low/Off:** Change the volume of the ringer on the handset or turn the ringer off.
- 5 **Contrast:** Adjust the brightness of the display for optimum viewing.
- 6 **PBX Number:** Determines if a "PBX Number" is used before an outgoing number is dialed. Select a number (0-9) which is necessary to dial out when using a switchboard system, and the phone will automatically dial the PBX number and a pause before any speed dial or caller ID callback number. Default setting is "Off".
- 7 **Flash Time:** Allows you to adjust the flash time to accommodate the phone service in your area.

SETTINGS

Changing the Pause Time

1. Press and hold the **(Menu)** key to enter the menu.
2. Press **(8 TUV)** to go to the pause time programming option.

PAUSE TIME
2
#8 10:11
3. Press **(Flash)** /EDIT to change the setting. "2" will begin flashing.
4. Use the **▲▼** key to select the desired dialing delay.
5. When the setting you desire is displayed, press and hold **(Redial)** /SAVE to save the setting. A long beep will sound to confirm the setting has been saved.
6. Continue with programming or press **(Menu)** to return to the idle screen.

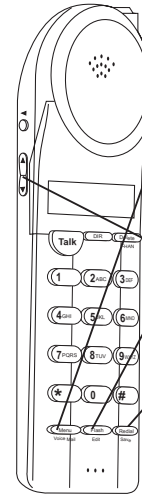

Programming One-Touch Voice Mail Dialing

1. Press and hold the **(Menu)** key to enter the menu.
2. Press **(9 WXYZ)** to go to the auto answer programming option.

VOICE MAIL
#9 10:11
3. Press **(Flash)** /EDIT to enter your voice mail speed dial number.
4. Use the dial pad to enter the phone number used to access your voice mail messages (up to 16 digits). Press **(Redial)** to insert a dialing pause.
5. When the phone number you desire is displayed, press and hold **(Redial)** /SAVE to save the setting. A long beep will sound to confirm the number has been saved.
6. Continue with programming or press **(Menu)** to return to the idle screen.

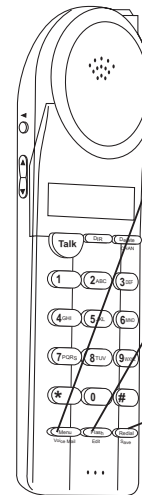

SETTINGS

Setting the PBX Number

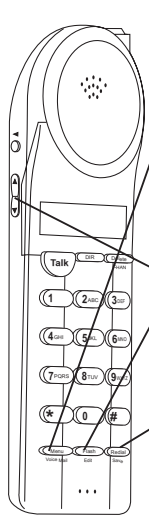
- 
1. Press and hold the **Menu** key to enter the menu.
 2. Press **6 MNO** to go to the PBX number programming option.

PBX NO.
 OFF
 #6 TOTAL 11
 3. Press **Flash** /EDIT to change the setting. "OFF" will begin flashing.
 4. Use the **▲▼** key to customize the digit to match your PBX system. When not connected to a PBX, the phone will only function normally when set to "OFF".
 5. When the setting you desire is displayed, press and hold **Redial** /SAVE to save the setting. A long beep will sound to confirm the setting has been saved.
 6. Continue with programming or press **Menu** to return to the idle screen.

Changing the Flash Time

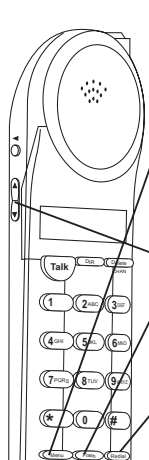
- 
1. Press and hold the **Menu** key to enter the menu.
 2. Press **7 PQRS** to go to the flash time programming option.

FLASH TIME
 600
 #7 TOTAL 11
 3. Press **Flash** /EDIT to change the setting. "600" will begin flashing.
 4. Use the **▲▼** key to select the desired dialing delay.
 5. When the setting you desire is displayed, press and hold **Redial** /SAVE to save the setting. A long beep will sound to confirm the setting has been saved.
 6. Continue with programming or press **Menu** to return to the idle screen.

Note: The standard and default flash time setting is 600msec. This is the setting you should use to access standard telephone services such as call waiting. This setting is adjustable to allow for PBX and other special uses.

SETTINGS

Key Function

- 8 TUV** **Pause Time:** Allows you to adjust the number of seconds that a pause lasts such as during programmed pauses in your speed dial numbers or after your PBX number is dialed.
- 9 WXYZ** **Voice Mail:** The programmed one-touch number designed to enable easy access to voice mail service provided by your telephone company.
- 0** **MSG Waiting Delete:** Clears any current message waiting indication.

Note: At any time during options programming you can quit and the settings that you have changed will be saved. Press **Menu** to quit the options menu or let the options programming time out by not pressing any keys for 20 seconds.

Changing the Language

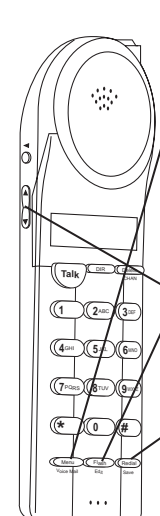
- 
1. Press and hold the **Menu** key to enter the menu.
 2. Press **1** to go to the language programming option.

ENGLISH
 #2 TOTAL 11
 3. Press **Flash** /EDIT to change the setting. "ENGLISH" will begin flashing.
 4. Use the **▲▼** key to toggle between ENGLISH, ESPANOL, and FRANCAIS.
 5. When the setting you desire is displayed, press and hold **Redial** /SAVE to save the setting. A long beep will sound to confirm the setting has been saved.
 6. Continue with programming or press **Menu** to return to the idle screen.

SETTINGS

Silent On or Off

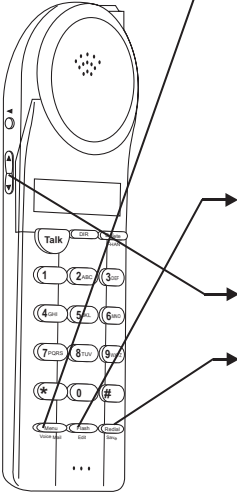
- 
1. Press and hold the **Menu** key to enter the menu.
 2. Press **2 ABC** to go to the silent programming option.
- SILENT**
OFF
#3 TOTAL 11
3. Press **Flash** /EDIT to change the setting. "On" will begin flashing.
 4. Use the **▲▼** key to toggle between On and Off.
 5. When the setting you desire is displayed, press and hold **Redial** /SAVE to save the setting. A long beep will sound to confirm the setting has been saved.
 6. Continue with programming or press **Menu** to return to the idle screen.

Setting the Time and Date

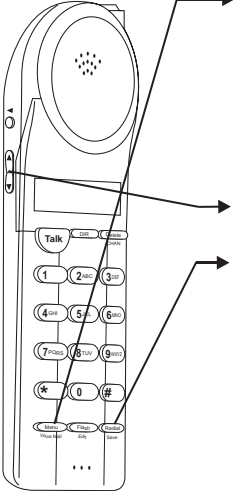
- 
1. Press and hold the **Menu** key to enter the menu.
 2. Press **3 DEF** to go to the time set programming option.
- TIME SET**
8:02^{AM} 12/25 #4 TOTAL 11
3. Press **Flash** /EDIT to change the setting. The month will begin flashing.
 4. Press the **▲▼** key to enter the month, date, hour and minute to move cursor, Press the **▶** key or the **◀** key.
 5. When the setting you desire is displayed, press and hold **Redial** /SAVE to save the setting. A long beep will sound and you are returned to the options menu.
 6. Continue with programming or press **Menu** to return to the idle screen.

SETTINGS

Setting the Ringer Level

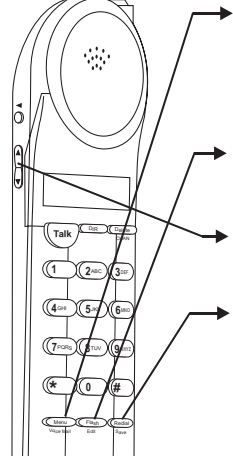
- 
1. Press and hold the **Menu** key to enter the menu.
- RING:HI**
#1 TOTAL 11
2. Press **Flash** /EDIT to change the setting. "HI" will begin flashing.
 3. Use the **▲▼** key to toggle between HI, LOW, and OFF.
 4. When the setting you desire is displayed, press and hold **Redial** /SAVE to save the setting. A long beep will sound to confirm the setting has been saved.
 5. Continue with programming or press **Menu** to return to the idle screen.

Adjusting the Contrast

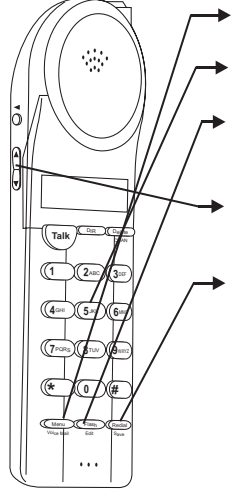
- 
1. Press and hold the **Menu** key to enter the menu.
 2. Press **5 JKL** to go to the contrast programming option.
- CONTRAST**
3
#5 TOTAL 11
3. Press **Flash** /EDIT to change the setting. "3" will begin flashing.
 4. Use the **▲▼** key to toggle between the three levels of contrast.
 5. When the setting you desire is displayed, press and hold **Redial** /SAVE to save the setting. A long beep will sound to confirm the setting has been saved.
 6. Continue with programming or press **Menu** to return to the idle screen.