

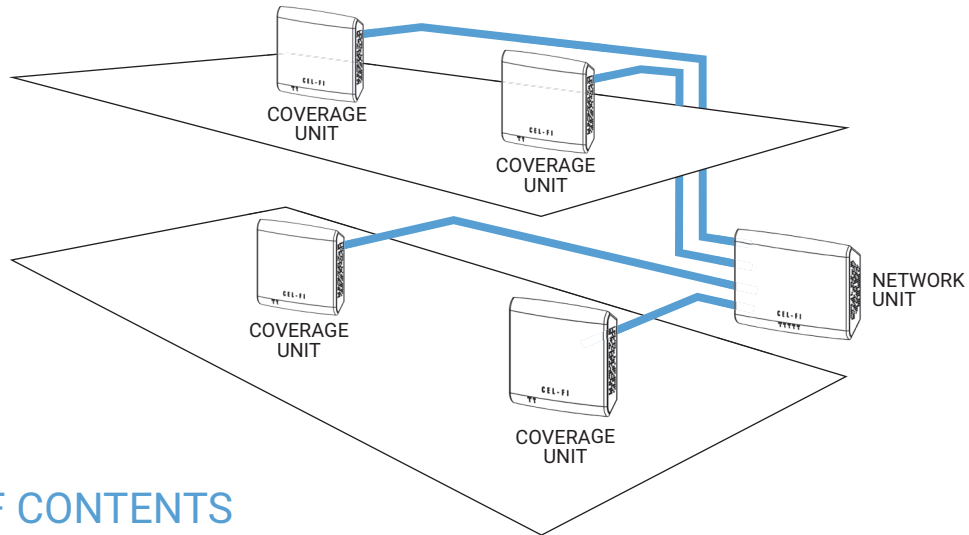

Cel-Fi QUATRA

Networked Smart Booster™

Cellular Coverage for your Business



■ TABLE OF CONTENTS

INTRODUCTION: Cel-Fi QUATRA	2
CONFIGURATIONS: Cel-Fi QUATRA System	2
OVERVIEW	3
PLANNING	3
Decide on the System Configuration	3
Plan NU Placement based upon System Configuration	4
Plan CU Placements	5
Plan Cabling	6
System Installation	7
STEP 1 – Record QUATRA serial numbers	7
STEP 2 – Mount QUATRA Hardware	7
STEP 3 – Route and connect all Cat 5e (or better).....	8
STEP 4 – Power the Network Unit and Commission the system	9
TRUBLESHOOTING:	
Quatra	11
Accessories	12
SPECIFICATIONS	12
TERMINOLOGY	13
FCC STATEMENT	13
WARRANTY	13

■ INTRODUCTION: Cel-Fi Quatra

Cel-Fi QUATRA is a simple to install 3G/4G/LTE enterprise class Networked Smart Booster™. A single system is comprised of one Network Unit (NU) and up to four Coverage Units (CU). The NU accepts Donor signals from either the outside cellular network or a locally installed Small Cell, and passes that service over Cat 5e (or better) cabling to CUs mounted where cellular service is needed.

The CUs contain their own transmit amplifiers and are powered from the NU through Power over Ethernet (PoE). This allows for flexible placement of the CU's since AC power at the site of each CU is not required.

With four (4) Coverage Units, a combined in-building coverage range of up to 50,000 ft² per system can be achieved. For larger coverage area, multiple QUATRA systems may be used.

Cel-Fi QUATRA systems are self-configuring and can be fully managed from Nextivity's WAVE Portal. Status notifications and alarms are fully customizable.

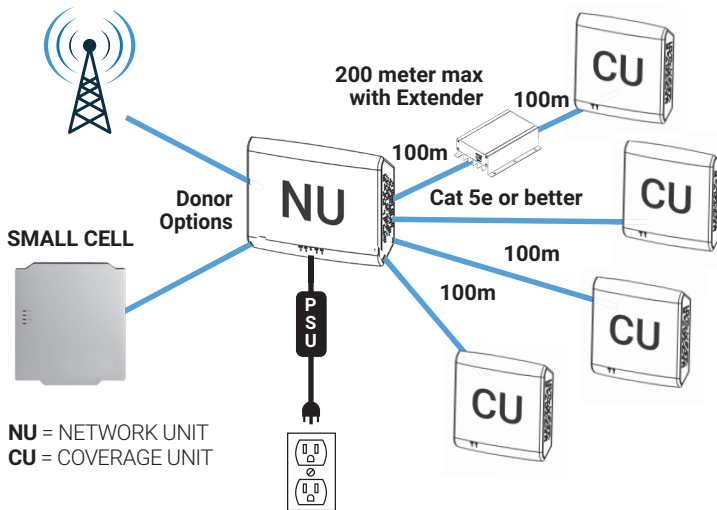

COVERAGE UNITS (CU)

- Up to four (4) per NU
- Power over Ethernet
- Built-in or External antennas
- Horizontal ceiling or vertical wall mountable
- Mounting Kit included

NETWORK UNIT (NU)

- Built-in or external donor antennas
- Accepts Small Cell donor inputs (to one or more QUATRA systems)
- Powers entire system
- Self-configuring
- Mounting Kit included
- Enterprise management

IMPORTANT

 We recommend watching the QUATRA videos on www.Cel-Fi.com as a quick way to learn about the system and how to install it.

■ CONFIGURATIONS (MODE): Cel-Fi QUATRA System

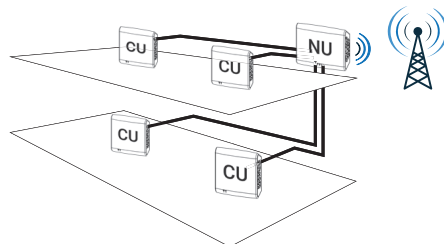

Off-Air Donor using Internal Antennas

BEST FOR: Basic install if an excellent donor signal exists somewhere inside the building, and coverage in a remote area is the main problem.

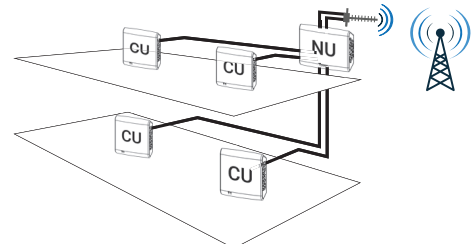

Off-Air Donor using External Antennas

BEST FOR: Most off-air installations. This is the recommended use case of an off-air QUATRA system.

Small Cell Donor

BEST FOR: Large scale deployments to add dedicated local capacity or to resolve interference issues. Use this configuration when connecting a small cell to one or more QUATRA systems.

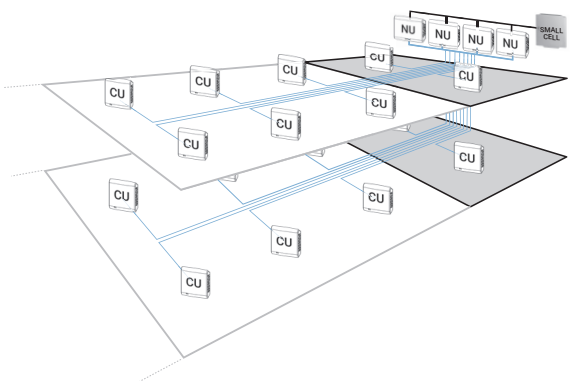

OVERVIEW



PLANNING

Decide on your configuration and where QUATRA components will go, including NU to CU interconnect cables to make sure their lengths do not exceed 100 meters per CU (200m with QRE – QUATRA Range Extender).

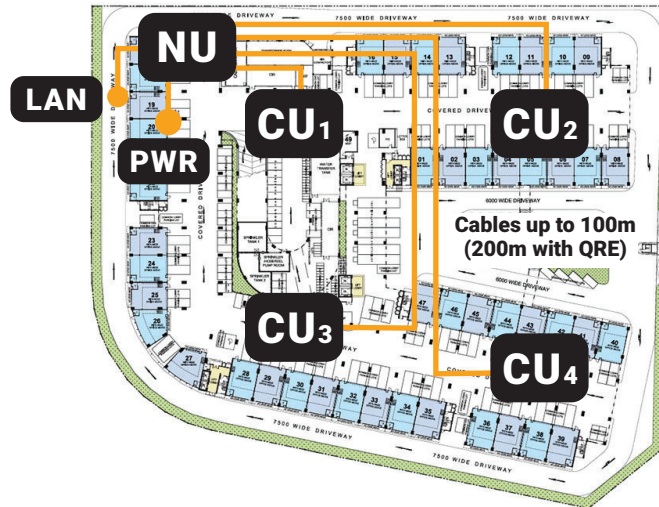

Decide on the System Configuration (Mode)

Use the table below to determine the recommended donor input configuration for your installation site. Off-Air donor refers to the use of antennas to receive and redistribute the outdoor macro network service where you need it indoors. Small Cell donor refers to the use of a dedicated small cell device (usually available through your operator) as the network signal source.

	Existing Service using your phone (bars of signal)	
Coverage Need	Weak Cellular service (0-2 bars), reliable calls where signal exists.	Signal exists but calls unreliable, or available small cell does not cover all required areas.
20,000 ft² many walled rooms	Off-Air input	Small Cell input
≤ 50,000 ft² open area	Off-Air input	Small Cell input (may need >1 QUATRA)
≥ 50,000 to 200,000 ft²	Small Cell input to multiple QUATRAs	Small Cell input to multiple QUATRAs

Table 1 – Recommended Donor Source

When amplifying the existing outdoor network, service is being shared with other users on the macro network (your outside cellular experience should become your inside cellular experience). When using a dedicated small cell input, capacity is being added to the operator’s network at your install site which also helps resolve capacity or interference problems.

NU Placement based upon System Configuration

Off-Air Donor

To meet regulatory compliance and to assure optimum performance, the approved Cel-Fi External Antenna must be used (refer to Legal Insert for a list of approved antennas). The WAVE Portal is used to simplify this step. For applications in rural areas, the internal antennas of the NU may be used.

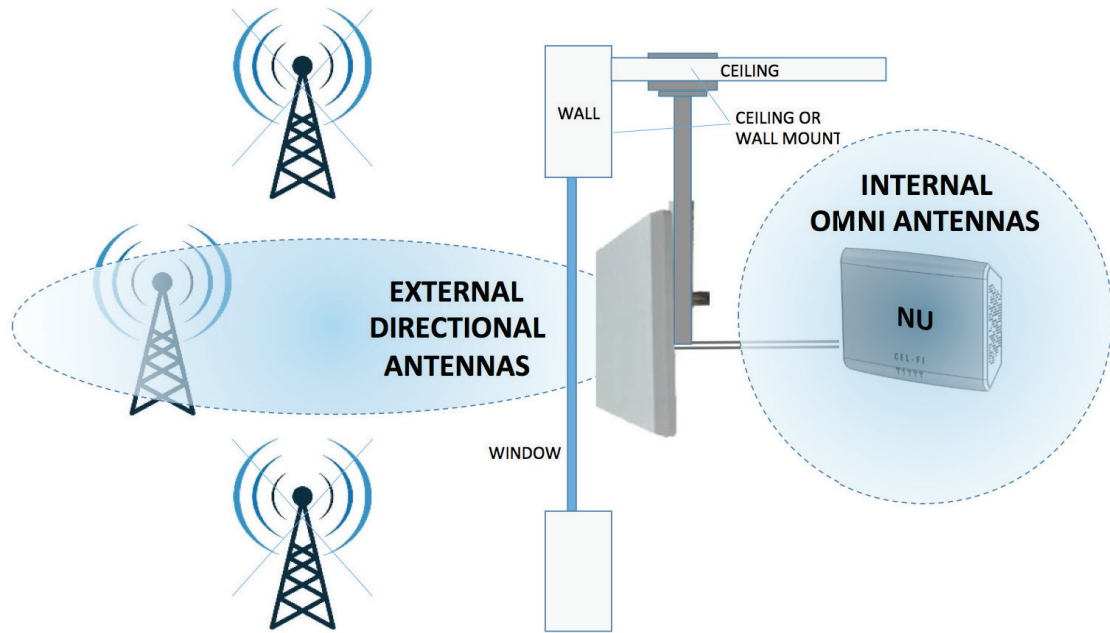

For best results, test donor signal locations during normal peak usage hours.

1. Determine best existing Off-Air signal location in the building (using phone signal bars), usually near windows.
 - a. OPTION: Run a few speed tests on a phone at each location. Higher data rates indicate better signal quality.
 - b. ADVANCED: Evaluate signal quality parameters (LTE: RSRQ and SINR/CINR; WCDMA: Ec/Io or CQI).

QUALITY INDICATORS	POOR	BEST(MAX)
LTE RSRQ dB	<-15	-3
LTE SINR dB	<0	+30
LTE CQI	0	15
WCDMA Ec/Io dB	<-16	-3
WCDMA CQI	0	30

2. NU Internal antennas are sufficient if signal quality is good. If signal quality is poor, use an external antenna.
3. NOTE: The approved external antenna supplied by Nextivity is intended for indoor use. If the antenna is to be mounted outdoors, the installer is responsible for proper lightning surge protection and cable weatherproofing (sold separately).

TIPS FOR NU PLACEMENT



- Plan to mount the NU within reach of an AC outlet.
- Plan cabling from the NUs to the CUs (use existing unused LAN distribution cables from a central patch panel, or plan to run new cables).
- If using internal NU antennas, it is best to not run or coil the cabling immediately behind the NU to avoid effects of metal close to the antennas.

Small Cell Donor:

This configuration connects one or more NUs directly to a small cell through a Small Cell Interface (SCIF) for signal distribution. Plan to mount both the small cell, SCIF and NU next to each other, and where there is easy access to LAN cabling and routing (such as an IT closet with pre-existing LAN patch panels).

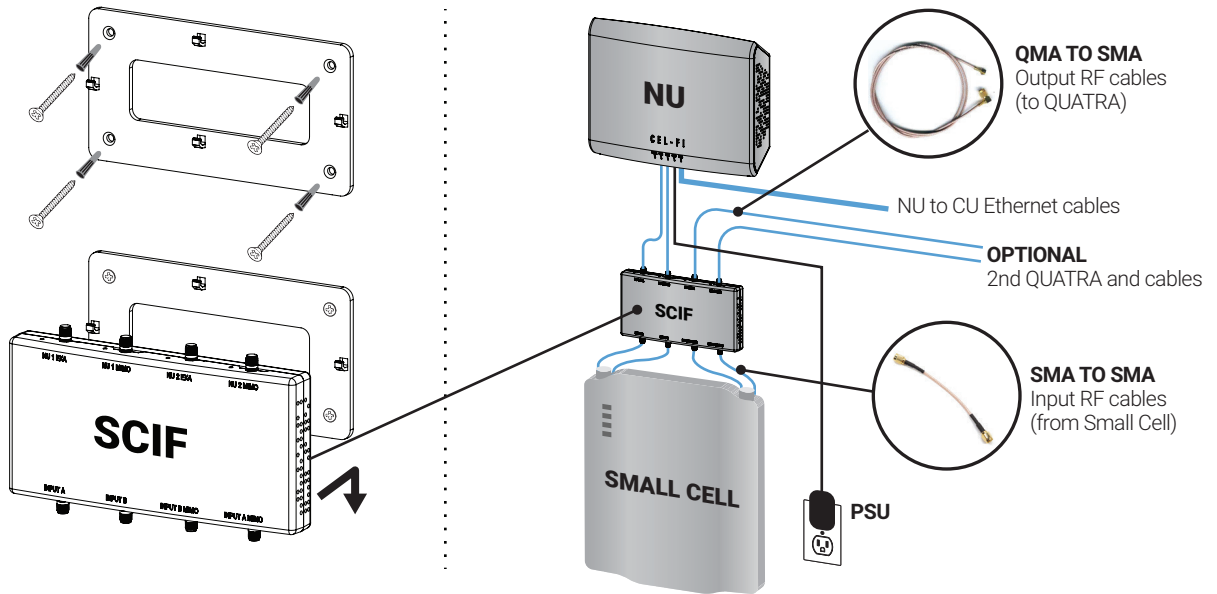

IMPORTANT



To prevent damage or out of specification operation, a QUATRA Small Cell Interface (SCIF) must be used when connecting QUATRA systems to a small cell.
The actual cabling between the small cell and QUATRA is described in the installation section of this guide.

Cabling Between the Small Cell and QUATRA

The QUATRA Small Cell Interface (SCIF) shown above contains the proper amount of signal attenuation and port isolation needed when connecting up to four (4) small cell RF ports to the RF ports of one or two QUATRA NUs. Choose the small cell to match the overall capacity you need and match the QUATRA system size to achieve the coverage you need. If more than two (2) QUATRA systems are to be used, contact your supplier or www.cel-fi.com/quatra for more information.

Installation Considerations for NUs and SCIF:

- Plan to mount all NUs and the small cell in the same location so they may be properly interconnected using the SCIF.
- The SCIF should be mounted above the Small Cell within reach of the Input RF cables.
- Make sure there is a suitable power outlet within reach of the NU power supply.
- Make sure there is room to route CU, LAN, power, and optional RF cables.
- Allow adequate ventilation.
- Do not place the NU close to other transmitting antennas.
- NU Faceplate LEDs should be clearly visible.

CU Placements

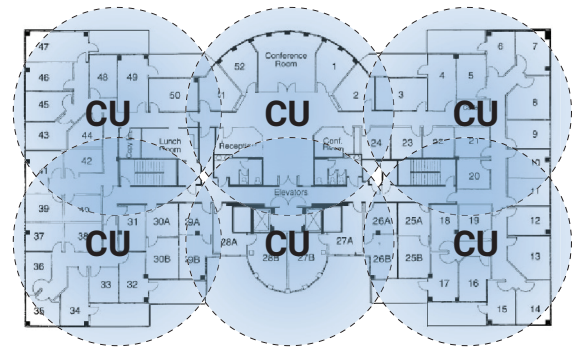
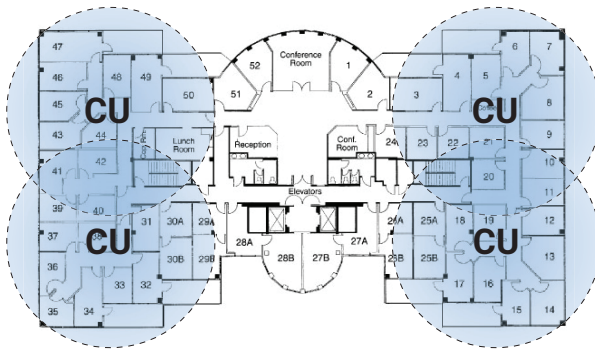

OPTIONAL: QUATRA Range Extender (QRE)

Off-Air Donor Coverage Units Where Needed

For Off-Air installs, mount Coverage Units where the macro network does not reach. Example, if a 100,000 ft² warehouse only lacks service in a few locations, then only use CUs in those locations.

Small Cell Donor Contiguous Coverage Units

For Small Cell donor configurations, mount the CUs to create continual coverage to ensure all areas benefit from the added small cell capacity.

Approximate Service Area (Coverage Unit)	Approximate Coverage Radius (Isolated Coverage Unit)	Distance Between Coverage Units (Contiguous Coverage)
Open areas (warehouse, parking structure)	33 meters	50 meters
Open office plan (cubicles)	21 meters	32 meters
Closed office plan (framed walls)	14 meters	21 meters
Closed room plan (masonry walls)	11 meters	16 meters

Table 2 – General CU coverage estimates

TIPS FOR CU PLACEMENT



- For best performance, mount the CU in an elevated position in open space.
- CU faceplate LEDs should be clearly visible.
- Off-Air Only: For maximum CU transmit power, do not mount CUs close to the NU antenna or the CU may reduce its transmit power to prevent RF feedback.

OPTIONAL: CU External Antennas

CUs contain internal omnidirectional MIMO antennas, and they are also equipped with external antenna ports in the event that directional antennas are desired, or if the signal needs to be split to feed multiple service antennas (splitter and cable losses will result in lower transmit power at the service antennas).

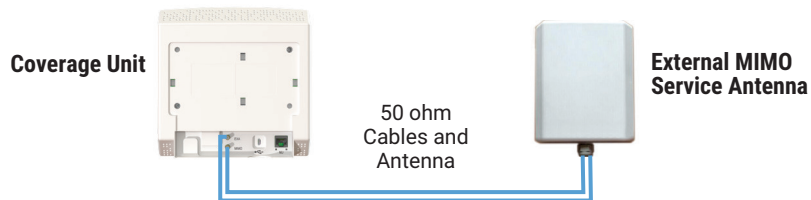

If external antennas are desired, place and mount the external antennas according to the antenna manufacturer's instructions and connect to the RF ports on the back of the Coverage Unit.

IMPORTANT



Ask your QUATRA supplier about antenna cables.

Cabling

QUATRA Cabling considerations

NU Power

- The NU should be located within reach of an AC power output.

NU LAN Management port (located on back of NU)

- The NU LAN port connects QUATRA to WAVE Portal through your LAN/ISP.

NU to CU cables

- Cat 5e (or better) must be used.
- These cables must not exceed 100 meters in length (unless a QUATRA Range Extender is used – see below).
- These cables must be dedicated to each CU.
- Passive cable interconnects may be used when routing the cables (such as a punch-down block or patch panel).
- Active Ethernet LAN hardware may not be used because QUATRA uses proprietary signaling.

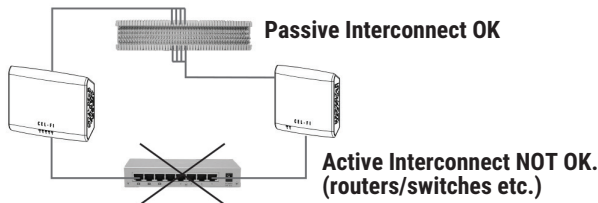
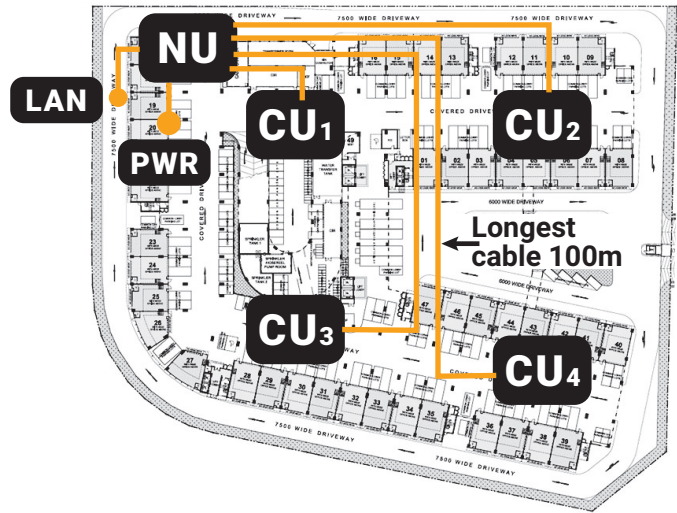

IMPORTANT

 **NU to CU Ethernet cables must be dedicated (proprietary data link)! The system will not function if common shared LAN resources are used (routers, switches etc).**

OPTIONAL: QUATRA Range Extender (QRE)

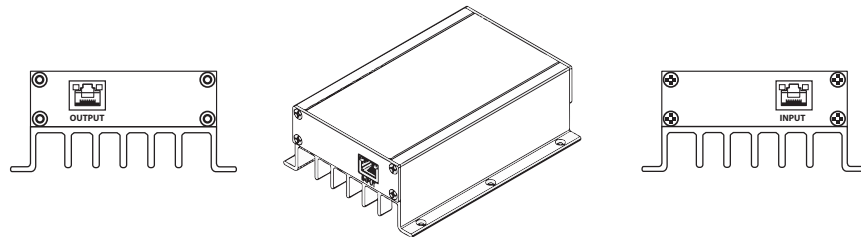

For NU to CU cable lengths exceeding 100m, a QRE may be used to extend cables up to 200m.

- Only one QRE may be used per CU.
- The QRE is powered by the cable from the NU (no local power source is needed).
- Install the QRE in accordance with the QRE User Manual.

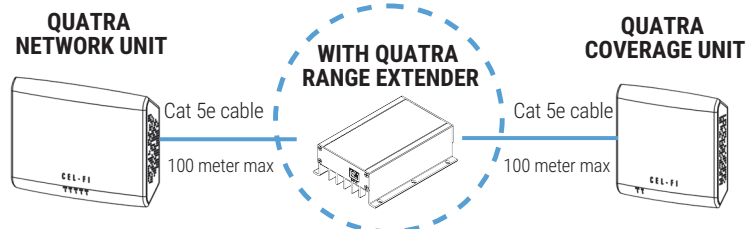

■ SYSTEM INSTALLATION

STEP 1: Record QUATRA NU and CU serial numbers by location

The QUATRA Management tools will reference the NUs and CUs by serial number during commissioning, and allow the assignment of personalized names to each unit.

STEP 2: Mount QUATRA Hardware

WALL MOUNT

Network Unit or Coverage Unit

Mark screw holes on plastic mount (A) onto wall. OPTIONAL: Trace rectangular area (B) if you are planning to run the cables through the wall.

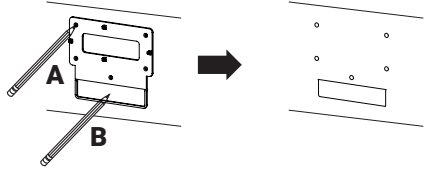

Drill holes into wall. Use a hammer to insert dry wall anchors. OPTIONAL: Cut rectangular area for cables with a dry wall saw.

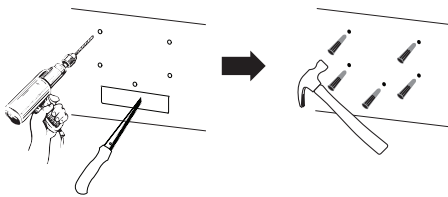

Attach the plastic mount to the wall with drywall screws. OPTIONAL: Route cables through wall cutout.

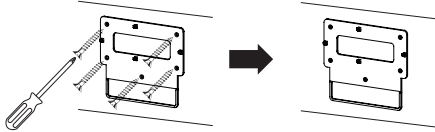

Plug cables into BACK side of unit and place BACK side of unit against plastic mount. Align the four holes over the four hooks and press downward until unit snaps into place.

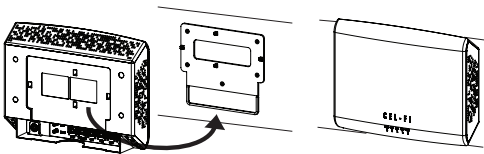

Network Unit Metal Stand-off Brackets

Temporarily attach metal brackets to plastic mount with machine screws. Mark screw holes on metal brackets onto wall.

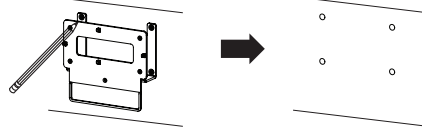

Drill holes into wall. Use a hammer to insert dry wall anchors.

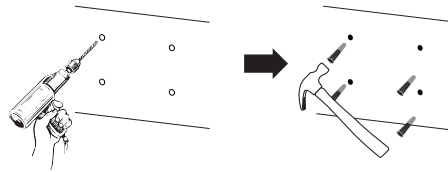

Attach the metal brackets to the wall with drywall screws.

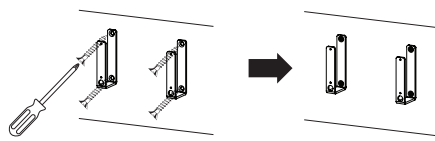

Attach the plastic mount to the metal brackets with machine screws.

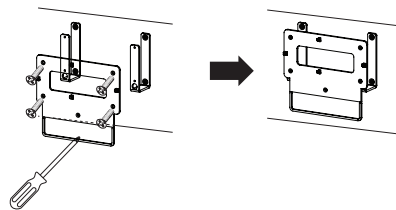

Plug cables into BACK side of unit and place BACK side of unit against plastic mount. Align the four holes over the four hooks and press downward until unit snaps into place.

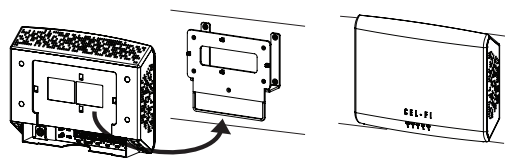

CEILING MOUNT

Coverage Unit Ceiling Tile Mount

Attach plastic mount on to the FRONT side of the ceiling tile with screws. The screw ends will be exposed on BACK side of ceiling tile. Attach metal plate on to the BACK side of the ceiling tile using the exposed screws.

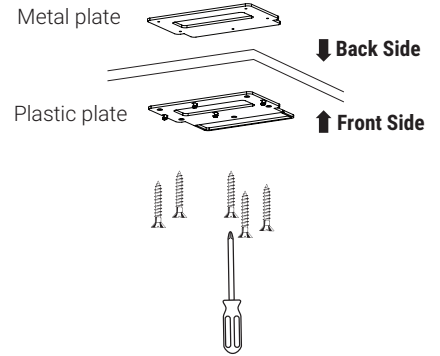

IMPORTANT



Do not overtighten the plastic mount screws.

Plug cables into BACK side of unit and place BACK side of unit against plastic mount. Align the four holes over the four hooks and press downward until unit snaps into place.

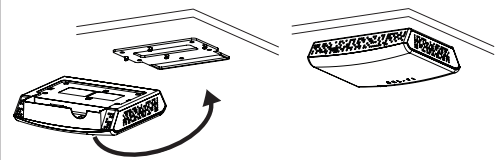

Accessories

For accessory installation, please refer to the instructions included with the accessory.

STEP 3: Route and connect all Cat 5e (or better) cables

NU to CU Cabling

Connect CUs in order CU1, CU2... (recommended)

If unsure of CU placement, leave extra cable to allow for CU relocating.

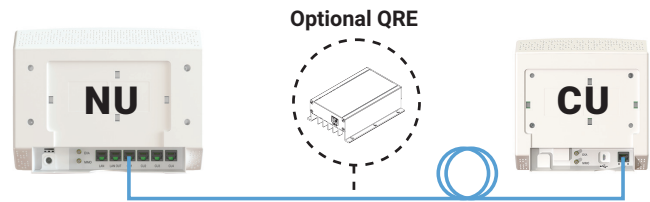

IMPORTANT

 **Do not power up the Network Unit at this time.**

LAN Cables are not provided with unit. End-use installer must choose correct LAN / PoE cables. The LAN cable must be as per requirements of CEC / NEC.

NU Management Connections

If multiple NUs are used for a Site, it is recommend to daisy chain the NU management ports (OUTPUT-LAN-OUTPUT-LAN...), or connect all NU LAN ports to the same LAN Subnet.

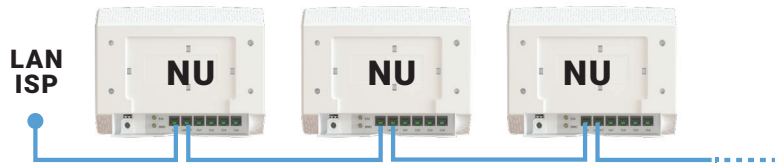

IMPORTANT

 **Remember to set Mode when commissioning the Unit. Choices are: Internal Antenna, External Antenna, or Small Cell.**

STEP 4: Power the Network Unit and Commission the system

IMPORTANT

 **1) If using a Small Cell, complete Small Cell commissioning before powering up.**
2) QUATRA commissioning using QMT or the WAVE portal is required for operation.

- Once a donor signal is available to the NU (Off-Air or Small Cell), plug in the NU power supply.
- Download and launch the QUATRA Management Tool (QMT) app from Google Play or the Apple App Store.

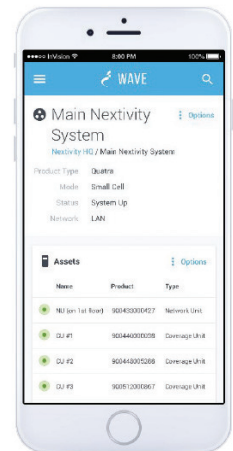

- Follow the on-screen prompts to connect to the QUATRA system over Bluetooth and complete the guided Commissioning steps (you must be within Bluetooth range of an NU or CU).
- Once Commissioning is completed, your QUATRA system should be providing service (the NU and CU front panel LEDs should be solid Green). If an LED is blinking green, wait for setup to complete. If any red LED indications persist, see Troubleshooting.

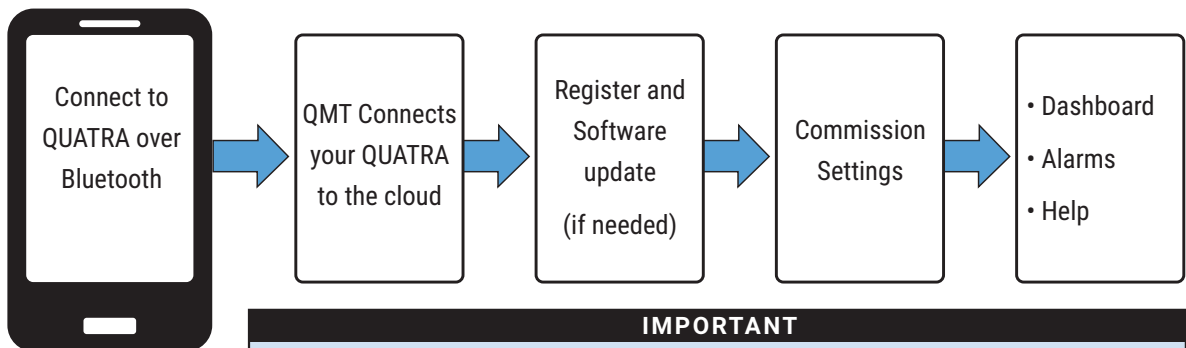





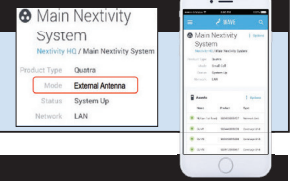

IMPORTANT

 **• Make sure that Mode is properly set to Internal Antenna, External Antenna, or Small Cell using QMT or WAVE Portal.**
• Make sure donor signal source is operational before powering up QUATRA.
• If any alarms, see Troubleshooting below.

IMPORTANT

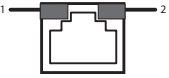
For detailed diagnostics, use the QMT app or the WAVE Portal



LED	ISSUE	TRY
 SOLID RED	Network Unit error.	Reset the Network Unit by unplugging the power supply, wait 5 seconds, then plug it back in. Verify Network Unit software is up to date (using QMT or cloud portal). If the problem persists, return Network Unit for service.
	Network Unit overheating.	Make sure that the vents (the small openings in the plastic housing) on the units are not blocked. Move the unit to a cooler area. The system will start working normally when it cools down.
	Coverage Unit (CU) Error	Reset the Coverage Unit by unplugging it and then plugging it back in. Verify Coverage Unit software is up to date (using QMT or cloud portal). Make sure that the LAN cabling to each Coverage Unit is dedicated (not combined with other active LAN hardware such as routers and switches). Passive connectors may be used (i.e. punch-down blocks) but the maximum cable distance may be reduced. If a QUATRA Range Extender is used to lengthen the 100 meter maximum Network Unit to Coverage Unit Ethernet distance, make sure only a single QUATRA Range Extender (QRE) is used per Coverage Unit. QRE is proprietary and other extenders will not work. See QRE Troubleshooting. Uninstall Coverage Unit and plug it into back of Network Unit with a short Ethernet cable that is known to work. If the Coverage Unit works properly, troubleshoot the original Ethernet cable (or QRE if used). If the problem persists, return Coverage Unit for service.
	Coverage Unit overheating.	Make sure that the vents (the small openings in the plastic housing) on the units are not blocked. Move the unit to a cooler area. The system will start working normally when it cools down.
 BLINKING RED	Donor power below minimum Threshold.	Insufficient Donor Signal. If internal antennas used for Network Unit, relocate Network Unit where signals exist or add and Enable external antennas in Settings. If external antennas or Small Cell donor signal used, verify external antennas Enabled in Settings and check coaxial feeds and connectors to Network Unit.
	Registration required.	Product Registration is required for your system to operate. Please follow the registration instructions using QMT or the WAVE portal.
	System disabled.	The system has been remotely disabled. Please check for a notification message and contact your Operator or Vendor.
 All RJ45 port LEDs flash off repeatedly	Input signal too strong.	The Network Unit is receiving too strong a donor signal and may operate with reduced gain or may switch to internal antennas to protect itself (the signal source could be any Operator's cell tower if close enough, or it could be another indoor cellular solution in close proximity to the Network Unit donor antennas). If internal antennas used, move the Network Unit to another location. You might need to move your system to the other side of your building. If external antennas used, move or re-aim the external antennas away from the strong cellular signal source. If a Small Cell donor is used, make sure the coaxial connections to the Small Cell have the supplied attenuators installed.
	Location Lock – Registration Required	Your system has been moved from its previous Registration location. Please reregister your system at its new location using QMT or the WAVE portal, or move the system back to its original location.
 QMT/WAVE	Port keeps resetting	A Coverage Unit LAN cable may be shorted. Unplug all Coverage Units, power cycle the system, and plug Coverage Unit cables back in one at a time to check where fault occurs (fault could be in cabling, a QUATRA Range Extender, or a Coverage Unit). If QUATRA Range Extenders are used, verify that LAN cable length on either side of the Extenders does not exceed 100 meters. If none of the above works, try another power supply. If none of the above works, try another Network Unit.
	Management Connection Error	Verify that a live LAN Ethernet cable is connected to the Network Unit LAN port (not the LAN OUT port which is used to daisy-chain to another Network Unit LAN port). Check LAN firewall settings to the cloud (contact your IT Administrator). Verify system performance and WAVE cloud portal connectivity using QMT (QMT must have an active internet connection).
 BLINKING GREEN	Setup in progress	Wait. System is in a setup state, which usually takes a few minutes but can take up to thirty (30) minutes if scanning for new channels in all bands.
 SOLID GREEN	Phones have signal but can't make calls	If using a Small Cell donor, make sure the small cell is commissioned and transmitting. Make test calls using just the Small Cell signal to verify its operation. Verify handset settings and compatibility against boosted channel bands and 3G/4G technologies. Advanced: Cellular connection problems are usually indicated by poor signal quality (3G:Ec/Io and CQI, LTE: RSRQ and SINR). Using a Small Cell can help eliminate Capacity and Interference problems that may be experienced from Off-Air donor signals.

■ Troubleshooting: Accessories

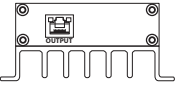
LED	ISSUE	TRY
QRE – ALL LEDs FLASHING		Unplug the INPUT cable, wait 5 seconds, and plug it back in. If the condition persists the unit needs to be replaced.
Any RJ45 green LED is off between NU/QRE/CU	Link is down	CU is not connected or cannot be seen. Check QRE to CU cable and/or CU. CU may be checked by plugging directly to back of NU or QRE Output with LAN test cable. Check NU – QRE – CU cables lengths (must not exceed 100 meters each, and use of patch panels may reduce maximum length).

■ Specifications

Supported Bands	2, 4, 5, 12
WCDMA Bandwidth per Band	3.84, 5, 10, 15, 20 MHz contiguous UMTS/HSPA channels
LTE Bandwidth per Band	5, 10, 15, 20 MHz contiguous (up to band max)
Channel Selection	Full Auto with self-learn Scan
Downlink TX Power max (conducted)	10dBm/5MHz (16dBm per band per antenna, 19dBm per band)
Uplink TX power max (conducted)	22dBm per band per antenna, 25dBm total per band
Max boost bandwidth (all channel)	75MHz
Maximum System Gain	100dB
System Gain dynamic range	0-100dB (real time echo controlled)
Internal MIMO antenna gains	0-2dBi (band dependent) V-H polarization
External RF connections	50 ohm QMA female Quick-Connect
Ethernet ports	Shielded Fast Ethernet ports (RJ45)
Maximum NU-CU cable length	100 meter (200 meter with QUATRA Range Extender accessory)
NU-CU LAN cabling	Cat 5e or better
Bluetooth (NU and CU)	Bluetooth Low Energy (BLE) v4.1.2
User Interface	Red/Green LEDs, QMT Smartphone App, WAVE Cloud Portal
Input Power (NU only)	54 VDC @ 2.22 Amp via external supply (51.3 to 56.7 VDC tolerance).
External Power Supply (NU only)	100 to 240 VAC, 47 – 63Hz.
Cooling	Natural convection
Network Unit dimensions	264mm (W) x 185mm (H) x 62mm (D)
Coverage Unit dimensions	225mm (W) x 185mm (H) x 36.5mm (D)
Network Unit weight	1.2 kg (40.8 oz.)
Coverage Unit weight	0.83 kg (29.2 oz.)
Operating temperature	0° to 40°C
Storage temperature	-25° to 60°C
Relative humidity	0% to 95%, noncondensing
IP Rating	IP20
Compliance	RoHS II 2011/65/EU 3GPP TS 25.143 Rel.10 3GPP TS 36.143 Rel.10 FCC Part 15, 20, 22, 24, 27 UL STD 62368-1 CSA STD C22.2 No. 62368-1 Bluetooth BQB

■ Terminology

Attenuator	An electronic device that reduces the amplitude of a signal.
Cel-Fi	An Operator specific Smart Signal Booster® that combines higher signal gain with network protection features.
Coverage Unit (CU)	The Cel-Fi unit that broadcasts cellular service where coverage is needed (Service signal).
Donor Antenna	Receives and transmits signals with the existing cellular network.
External Antenna	Antennas external to a device and connected with RF cables.
Gain, or System Gain	The amount of amplification that may be applied to the source signal.
iBwave	A solutions planner that allows you to perform complete RF distribution designs with hardware such as Cel-Fi products.
Interference	Locations usually between multiple cell sites that may be interfering with each other and reducing network capacity.
Isolation	Separating donor-service antennas to limit feedback potential.
MIMO	Multiple-Input Multiple-Output antenna scheme that improves capacity. QUATRA is a 2x2 MIMO system, using two antennas per NU or CU.
Network Unit (NU)	The Cel-Fi unit that connects to the existing cellular network (Donor signal).
Pilot Pollution	See Interference.
PoE (Power over Ethernet)	To pass electrical power along with data on Ethernet cabling.
QMA connector	A spring loaded quick connect small-size RF connector used to join coaxial cables.
QMT (QUATRA Management Tool)	A Smartphone App and cloud-based management system that allows local and remote management of QUATRA systems.
QRE (QUATRA Range Extender)	Allows QUATRA NU to CU interconnect cable lengths to 200m.
Service Antenna	Receives and transmits signals amongst local user devices (phones/tablets etc).
SMA Connector	A common small (Sub-Miniature A) 50 ohm RF cable connector.
Small Cell	Low-powered cellular radio access node.
Splitter (Divider/Combiner)	Splits a single coaxial cable to/from multiple cables.
WAVE	A cloud portal system for managing Cel-Fi systems.

■ FCC

(Applicable in the USA only)

This is a CONSUMER device.

BEFORE USE, you MUST REGISTER THIS DEVICE with your wireless provider and have your provider's consent. Most wireless providers consent to the use of signal boosters. Some providers may not consent to the use of this device on their network. If you are unsure, contact your provider.

You **MUST** operate this device with approved antennas and cables as specified by the manufacturer. Antennas **MUST** be installed at least 20 cm (8 inches) from any person.

You **MUST** cease operating this device immediately if requested by the **FCC** or a licensed wireless service provider.

WARNING. E911 location information may not be provided or may be inaccurate for calls served by using this device.

■ ADDITIONAL INFORMATION

To learn more about QUATRA and how to maximize performance in varying network situations, please visit our Tech Bulletin/White Paper section at www.Cel-Fi.com/quatra.

Warranty

For warranty information please visit us at www.Cel-Fi.com