

User Manual for 4 Channel Transmitter

TS401 2.4GHz



radiopost

■ General Information

Thank you for purchasing the Radiopost TS401 2.4GHz. The unique features of this product are introduced in this manual. Please read the instruction manual carefully and thoroughly for optimal enjoyment and control.

This RC system operates with a direct connection between the transmitter and its receiver, using a 2.4GHz digital frequency band. As others transmitters may use various frequencies or a crystal type FM band, Radiopost's TS401 2.4GHz system is free from interference to respond more quickly and accurately.

Radiopost TS401 2.4GHz is designed for all kinds of RC cars and boats. Whether it is on-road or off-road, at a pond or lake, Radiopost's products are made for various RC hobbyists. From beginners to experts, Radiopost wishes you the best as you set forth into the RC world with our specialized products.



Caution

- ▶ TS401 2.4GHz is a high powered RC system. Please check the maximum coverage distance and operation range for your safety.
- ▶ The 2.4GHz is an ISM band that can be used for devices or equipments other than RC hobby models. The use of different products in the same 2.4GHz bandwidth may cause frequency interferences among the products. So, before you start, check to see if the servos move properly and other connections, by performing a test run from the furthest distance possible.
- ▶ As various manufacturers and products may have different 2.4GHz technology, only the Radiopost receivers bind with the TS401.

■ Compliance Information Statement (for U.S.A.)

This device, trade name Radiopost, model number TS401, complies with part 15 of the FCC Rules. Operation is subject to the following two conditions:

- (1) This device may not cause harmful interference.
- (2) This device must accept any interference received, including interference that may cause undesired operation.

☞ It is prohibited to copy a part of or the whole of this manual.

☞ The contents of the manual may change without prior notice.

☞ If there are mistakes or missing parts in this manual, please contact us.

☞ In some cases, the manufacturer does not take responsibilities for the results which are brought upon by the customers.

■ Safety

- Before using the TS401 2.4GHz system, please carefully and thoroughly read this manual in order to use your RC system safely.
- Use this product in a safe manner, observing all safety precautions at all times.
- Please follow and observe all additional rules at the place of operation as suggested (i.e. race tracks, lakes, etc.) or wherever you use the RC system.
- If the RC model is not running properly, please immediately stop all controls. Do not run the RC model before completely fixing the problems.
- The RC model you use may cause injuries or damages. Please always be careful when running the RC system and models.
- Water or moisture may cause malfunctions to the system. Please keep the RC system away from water and moisture.
- For the RC boat, please install the receiver and servo in the waterproof box.
- If you are a beginner to the RC hobby, we strongly recommend that you seek the advice of experts who can assist you or contact your local RC hobby shop.

■ Precautions & Warnings

■ Precautions in Application, Export and Modification

- ▶ (Application) Do not use the transmitter for non-RC models. This product is not designed and intended for use in any application other than the radio control models for hobby and recreational purposes.
- ▶ (Export precautions) When this product is exported from the country of manufacturer, its use is to be approved by the laws governing the country of destination for the devices emitting radio frequency. If this product is then re-exported to other countries, it may be subject to restrictions on such export. Prior approval of the appropriate government authorities may be required. If you have purchased this product from an exporter outside your country and not an authorized Radiopost

distributors or dealer in your country, please immediately contact the seller to determine if such export regulations have been met. Use of this product with other than models may be restricted by the export and trade control regulations and an application for export approval must be submitted.

- ▶ (Modifications, Adjustment and Replacement of Parts) Radiopost is not responsible for the unauthorized modification, adjustment and replacement of parts on this product. Any such changes may void any or all warranties associated with this product.

■ Precautions for the Transmitter

- ▶ To start, first switch on the transmitter and secondly, the receiver. After using the RC Model, please switch off the receiver first and then the transmitter. Reversing the order of powering on and off may cause critical damages to the devices or persons.
- ▶ Please check if the batteries for transmitter and receiver are fully charged before starting.
- ▶ The antenna for Radiopost's transmitter TS450 2.4GHz is built-in the product (Internal). The antenna is located underneath the front top section, above the power switch of the transmitter. Be careful not to cover this part of transmitter, as it may cause weak signal output if covered.

■ Precautions for the Receiver

- ▶ The receiver antenna is made of coaxial cable that consists of a covered part and naked wire part. The naked wire is used to receive the radio wave. Be careful not to bend the naked part of the wire, as it also may weaken the signal quality of the receiver.
- ▶ An antenna cable is very delicate. Please handle it with care.
- ▶ Do not forcibly pull the antenna cable.
- ▶ Do not cut or link the antenna cable with other wires.

- ▶ Covered part of the antenna may be slightly made into a smooth curve. But do not fully bend it repeatedly or too sharply, which may cause unexpected problems with the antenna.
- ▶ The antenna must be installed in the plastic tube or antenna pipe to stand upright according to the RC model assembly instruction. It is highly recommended to mount the antenna of receiver away from the motor, the battery and the speed controller.
- ▶ If the connector of receiver shakes, an unexpected outcome may occur during controlling. Please check if the receiver, the servo and the switch connectors are firmly attached to the model.
- ▶ The receiver is sensitive to vibrations, impacts and humidity. Please take appropriate measures for the receiver to be kept away vibration, impact and humidity. If not, malfunctions or other problems may occur.
- ▶ When mounting the receiver, avoid any contact with carbon or metal chassis.
- ▶ The contact between metal components mounted on the product may cause electrical noise and may cause malfunctions and decrease the receiver's performance.
- ▶ The manufacturer is not responsible for the damages caused by the use of parts other than Radiopost's genuine components.



Warning

- ▶ Do not drive the models on rainy days, on damp or humid days and or at night. If the product(s) come in contact with water, malfunctions may occur to the transmitter and the model and may cause the systems be out of control.



Warning

- ▶ Use five AA-size dry cell batteries, five AA-size rechargeable batteries, or its equivalents only. Batteries other than specified above may cause serious damages on your TS401. Misuse of battery may void warranty.

Table of Contents

- **General Information**
- **Safety**
- **Precautions & Warnings**

1. Before Using

- 1.1 Features
- 1.2 Parts and Accessories
- 1.3 Nomenclature
- 1.4 Welcome Screen
 - 1.4.1 Vertical View
 - 1.4.2 Horizontal View

2. Personal Adaptation

- 2.1 How to Remove and Attach the Adapter for Wheel Extension
- 2.2 How to Change the Wheel Angle
- 2.3 How to Change the Wheel Position for the Left-handed Use

3. Functions and Description of Buttons

- 3.1 Edit Buttons
- 3.2 Trim Buttons
- 3.3 Dial Buttons
- 3.4 Push Switches

4. Function Map (Quick Menu/All Menu)

- 4.1 Quick Menu
- 4.2 All Menu

5. Description of Functions

- 5.1 Model
 - 5.1.1 Model Select
 - 5.1.2 Model Name
 - 5.1.3 Model Copy
 - 5.1.4 Model Reset
- 5.2 Subtrim
- 5.3 Dual Rate
- 5.4 EPA 1
- 5.5 EPA 2
- 5.6 Exponential
 - 5.6.1 Steer Exponential
 - 5.6.2 Throttle EXP

- 5.7 Reverse
- 5.8 Bind Receiver
- 5.9 Selection of Switch
 - 5.9.1 Push Switch
 - 5.9.2 Dial Switch
 - 5.9.3 Trim Switch
- 5.10 Speed
 - 5.10.1 Steer Speed
 - 5.10.2 Throttle Speed
- 5.11 Brake
- 5.12 Monitor
- 5.13 Adjust
- 5.14 Timer
- 5.15 LAP List
- 5.16 Edit Banner
- 5.17 System
- 5.18 Advanced
 - 5.18.1 Throttle Mode
 - 5.18.2 ABS
 - 5.18.3 TH-Acceleration
 - 5.18.4 AT-Start
 - 5.18.5 Idle-Up
 - 5.18.6 ATL
 - 5.18.7 AUX CH Position
 - 5.18.8 Boat Mode
 - 5.18.9 Prog Mix

- **Troubleshooting Guide**
- **Abbreviation**
- **Warranty**
- **Contact**

1. Before Using

1.1 Features

■ **2.4GHz radio communication system**

Frequency channel setting unnecessary and channel shifting takes place within the 2.4GHz band automatically. This system minimizes the interference from other 2.4GHz systems by using DSSS that has high signal transmission rate.

■ **Model memory for 20 models**

The model names can use letters, numbers and symbols so that logical names may be used.

■ **Two menu mode**

The menu is consist of 2 sub-menus – Quick menu and 8 Icons' menu – so that quickly and easily call the functions.

■ **Brake Mixing**

Brake mixing of the front and rear wheels can be adjusted independently.

■ **A.B.S system**

A.B,S function applies the brakes that gasoline engine cars do not lose their grip on the road even when braking at corners.

■ **ACCEL**

Gasoline engine cars have a time lag before the clutch and brakes become effective. The ACCEL function reduces this time lag.

■ **Throttle speed**

Sudden trigger operation on a slippery road surface will cause the wheel to spin and the model not to accelerate smoothly. By using the throttle speed function, operation can be performed smoothly and easily. It also suppresses battery consumption.

■ **Left-handed support**

The left and right installation direction of the wheel section can be reversed.

■ **Racing timer**

The racing timer can record total time and average lap time.
The race time and audible alarm can be set.

■ **Tension adjustment function**

The tension of the steering wheel & throttle trigger springs can be adjusted from the outside.

■ **Color LCD**

LCD can be adjusted with favorite color among blue, brown, green and background can be adjusted black or white.

■ **Rubber grip handle**

Rubber grip handle is designed for comfortable grip and control.

■ **Internal antenna**

The built-in antenna is applied for the convenience to carry around and cannot be broken.

1.2 Parts and Accessories

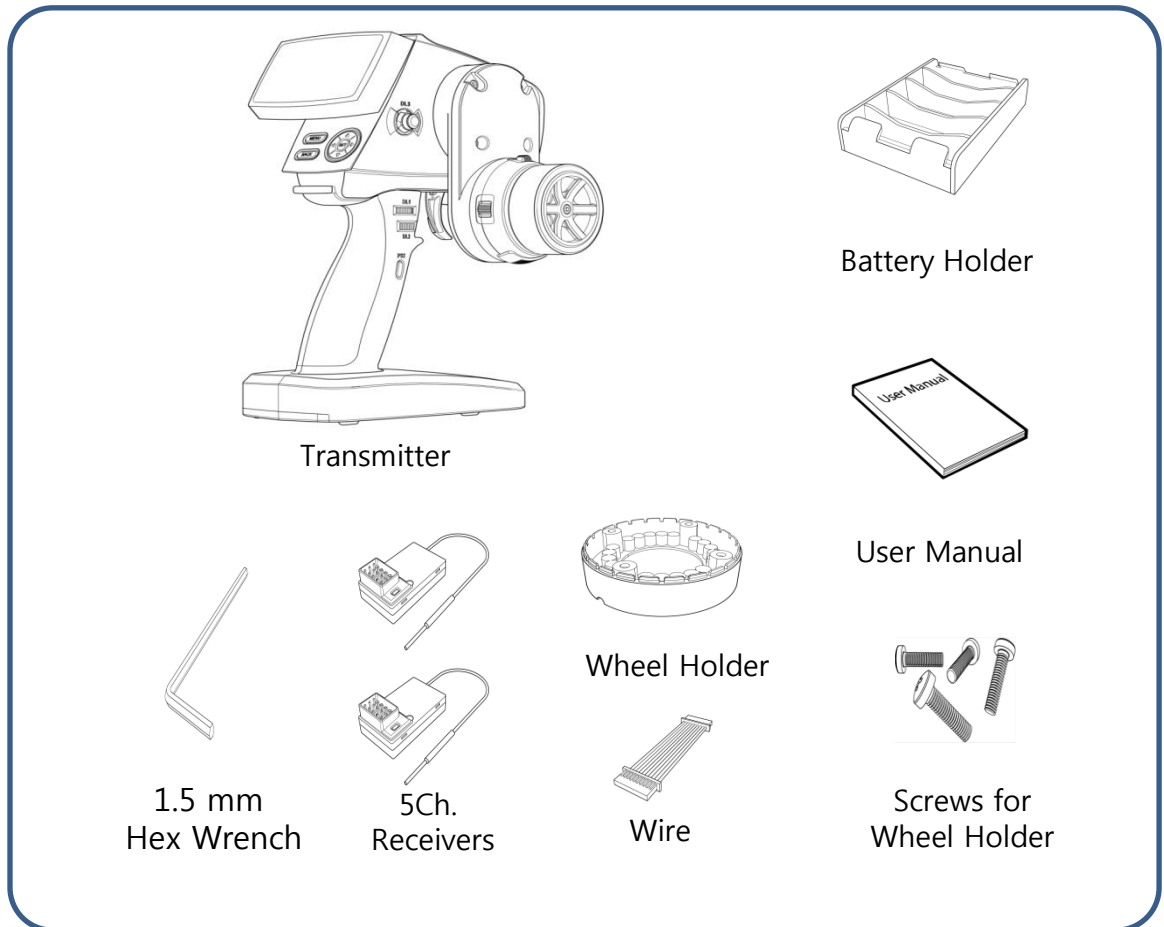

No.	Name	Description	Q'ty	Remarks
1	TS401 Transmitter	4Ch. Surface Transmitter	1	
2	RP24RS5D Receiver	5Ch. Receiver	2	
3	Battery Holder	Holder for AA Battery	1	
4	Wheel Holder	Holder for Wheel Set	1	
5	Wire	Wire Used with Wheel Set	1	
6	Screw	Screws for Wheel Holder	4	
7	Hex Wrench	Used for Personal Adaptation	1	
8	User Manual	User Guide for TS401	1	

1.3 Nomenclature

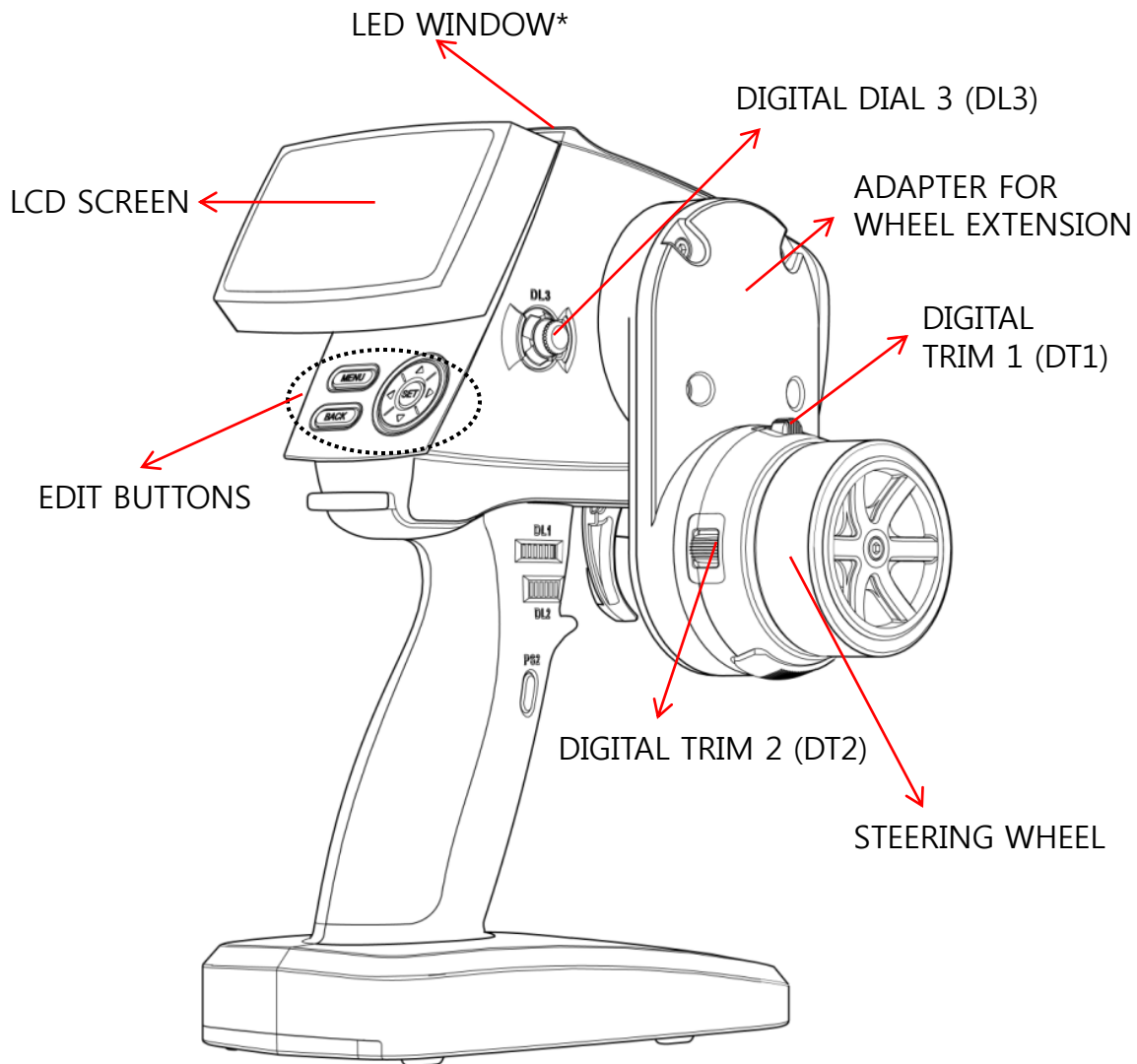

<LED Colors>

- RED: Lights if RF is turned off.
- GREEN: Lights if a receiver is bound.
- WHITE: Blinks if a receiver is not bound.
- ORANGE: Blinks if mixing is applied.

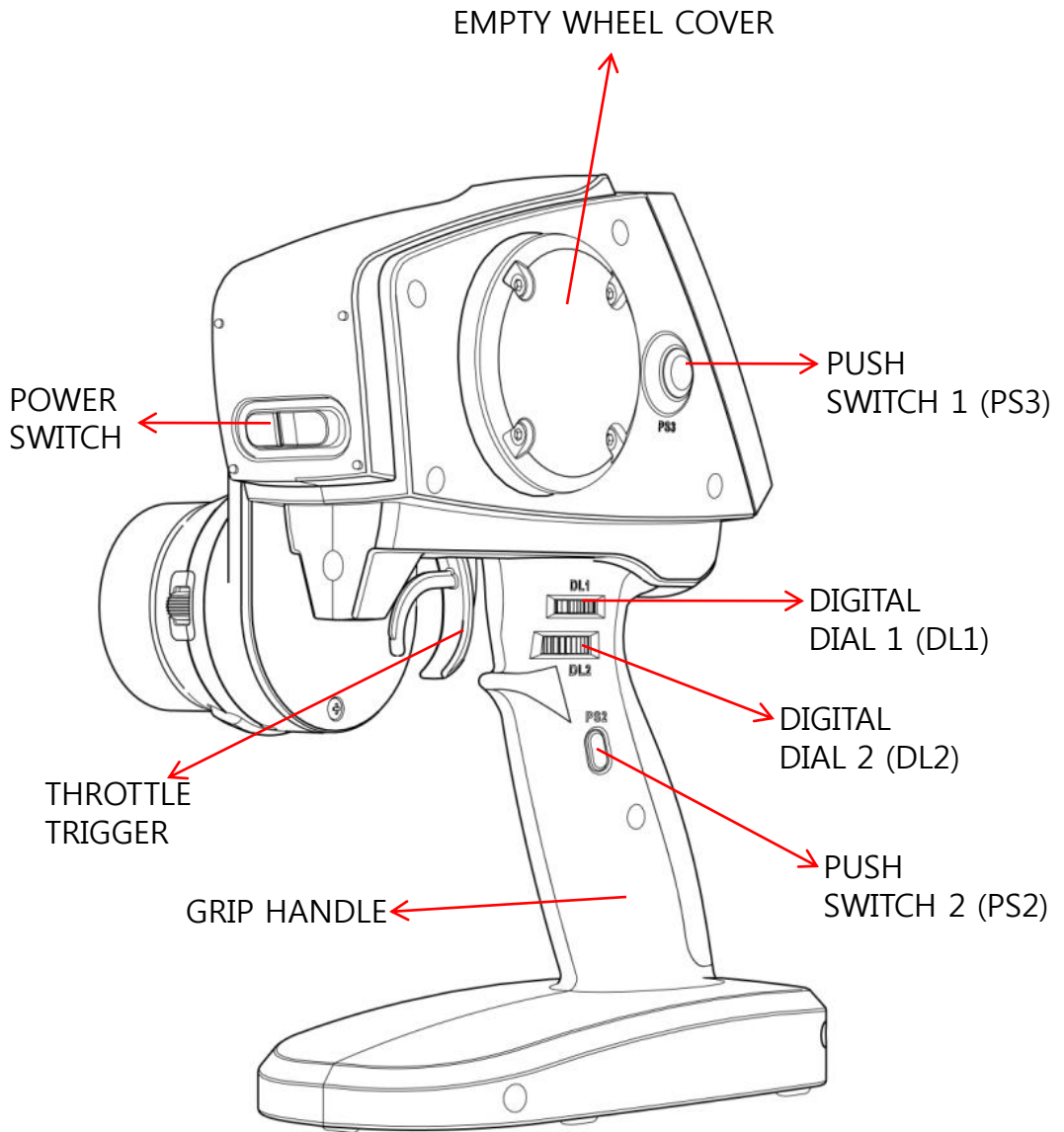

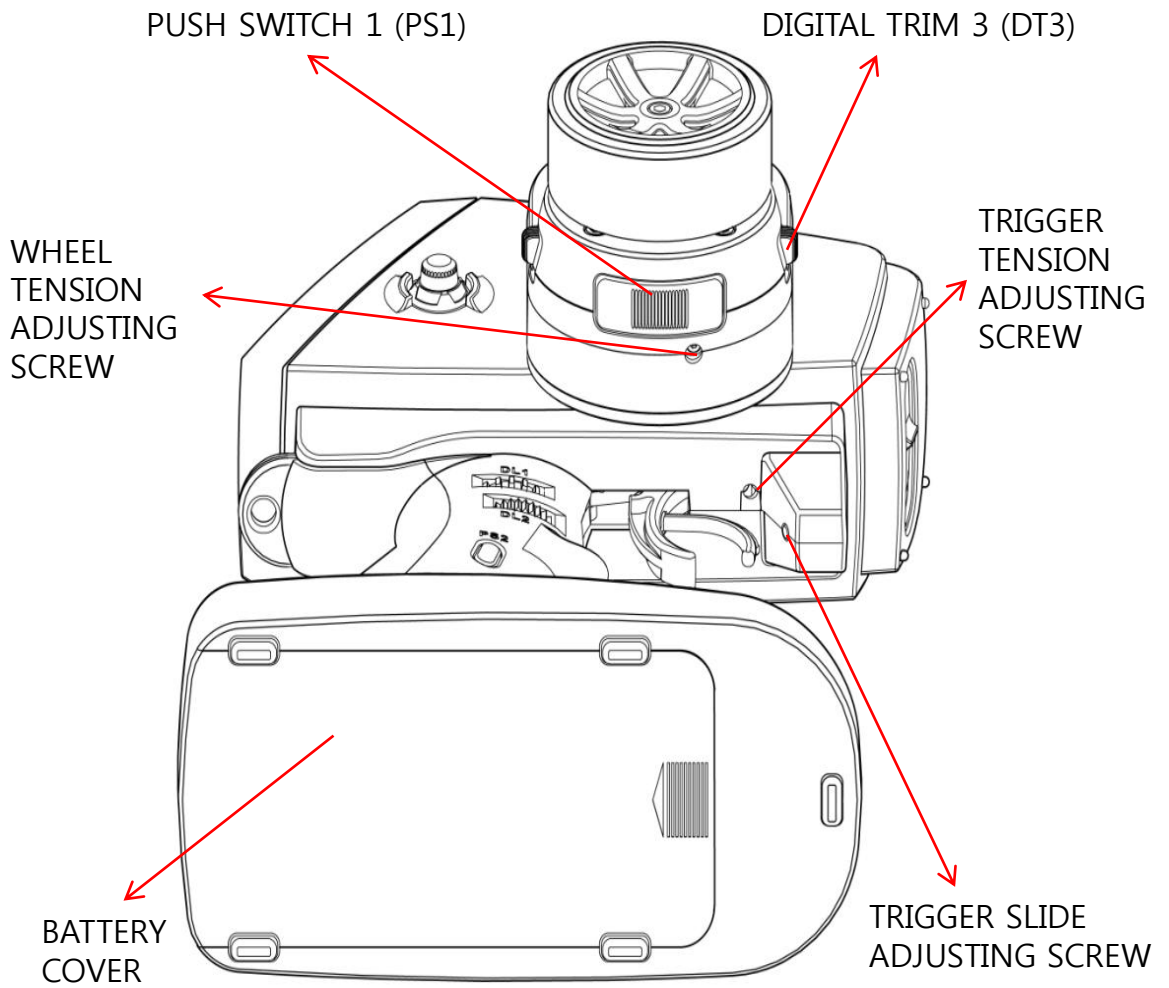

1.4 Welcome Screen

1.4.1 Vertical View

1) Normal Option Screen

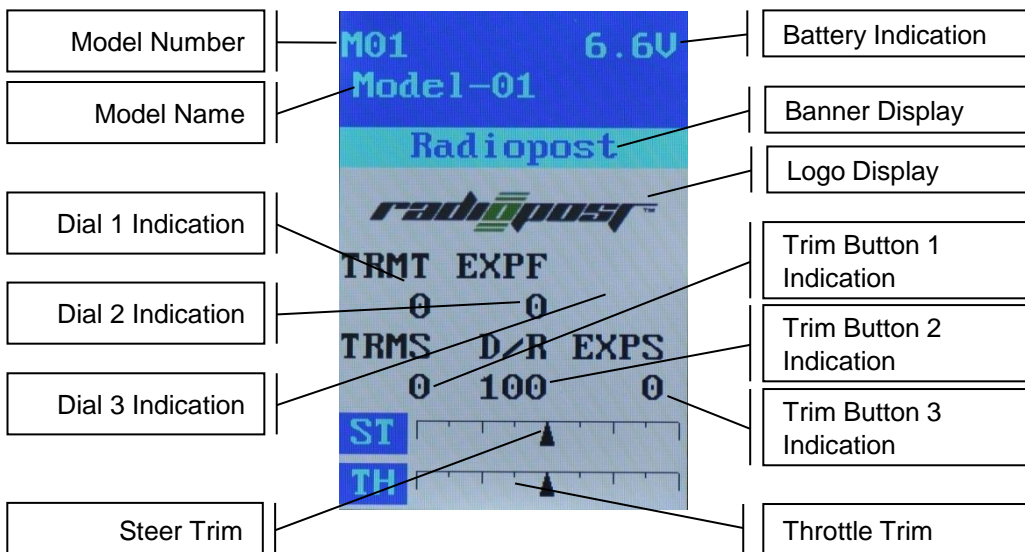

2) Time Option Screen

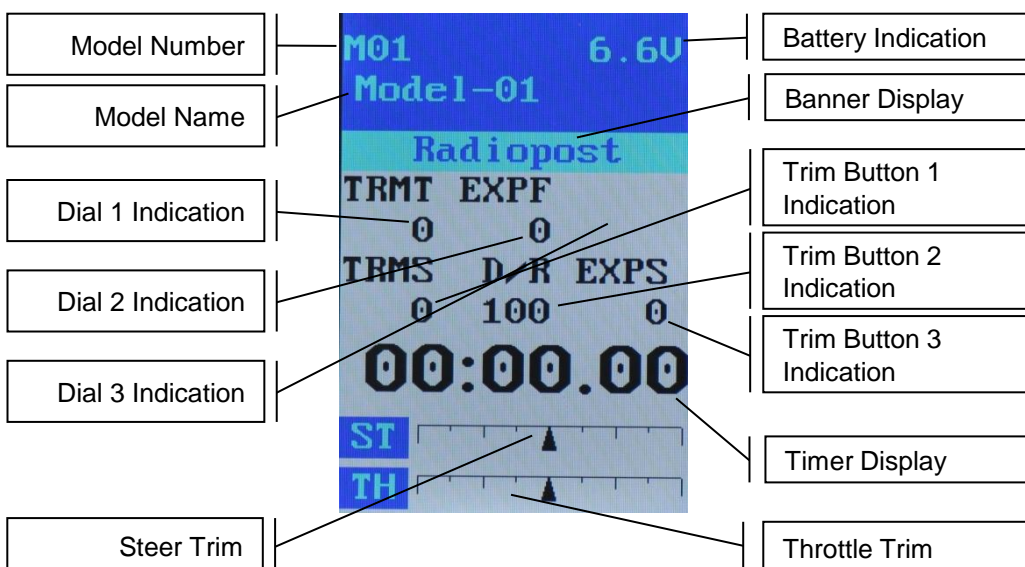

1.4.2 Horizontal View

1) Normal Option Screen

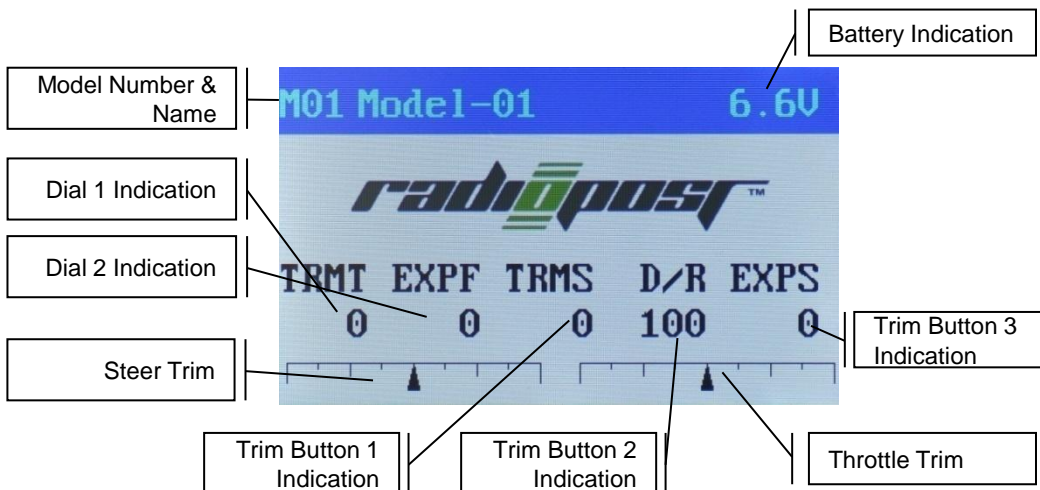

2) Time Option Screen

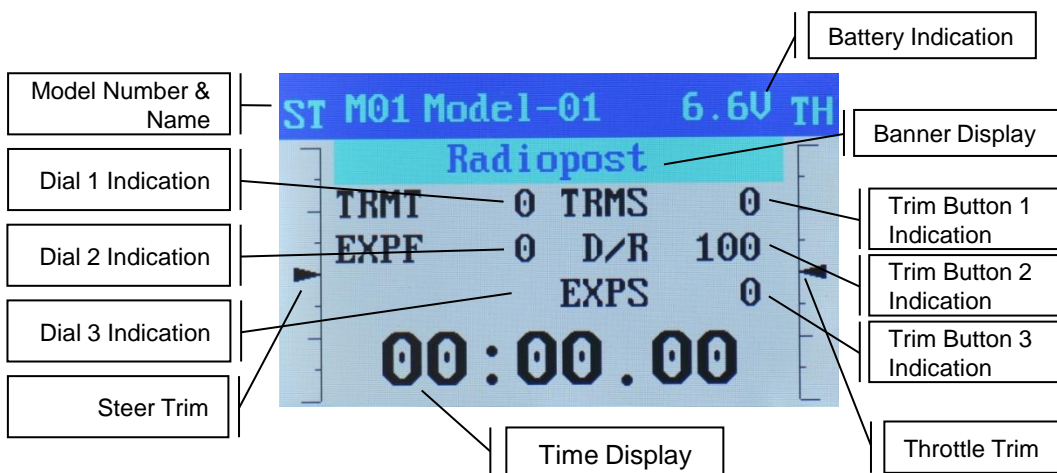

2. Personal Adaptation

Caution

TS401 2.4GHz can be adapted according to the user's preference. Be sure to POWER OFF before making any changes or preference setting.

2.1 How to Remove and Attach the Adapter for Wheel Extension

The wheel position of TS401 can be changed using the adapter for wheel extension. The adapter is assembled on the transmitter as a factory setup.

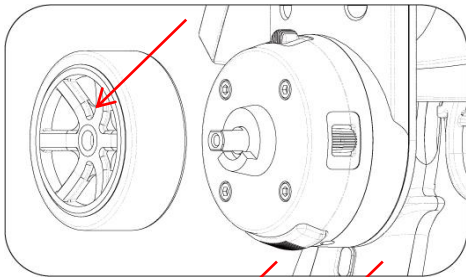

1. Detach the wheel by first taking off the screw at the center of steering wheel using the hex wrench.

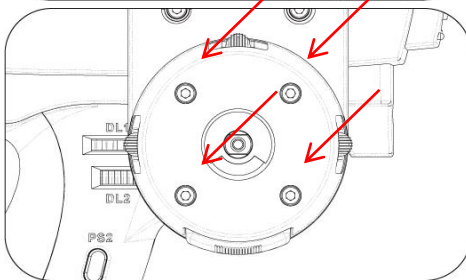

2. Take off the 4 screws on the wheel set.

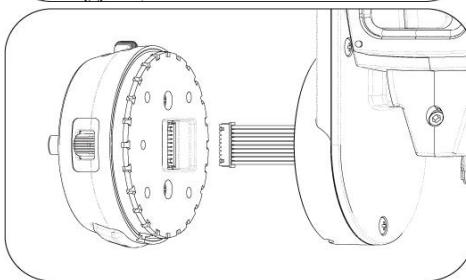

3. Separate the wheel set from the adapter and disconnect the wire.

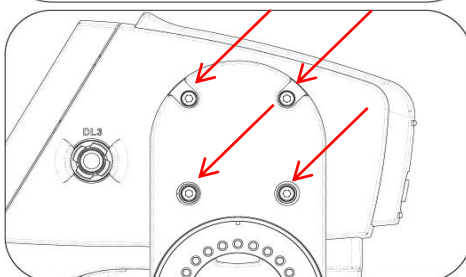

4. Take off the 4 screws on the adapter neck.

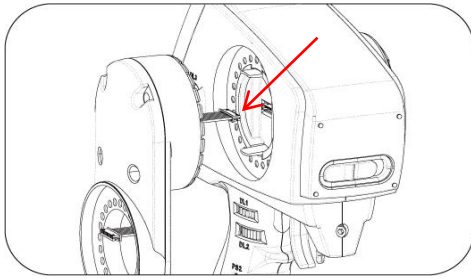

5. Detach the adapter from the transmitter body and disconnect the wire.

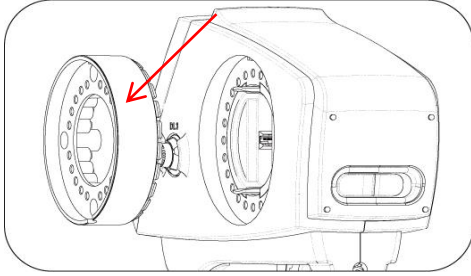

6. Attach the wheel holder separately provided.

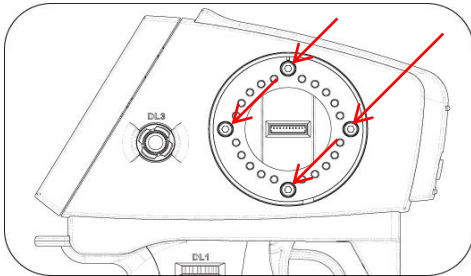

7. Screw in the 4 screws on the wheel holder. These screws are separately provided.

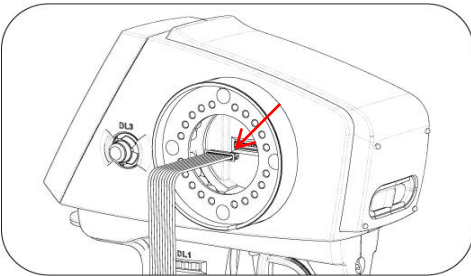

8. Plug in the wire to the transmitter body. Use the wire which is provided separately.

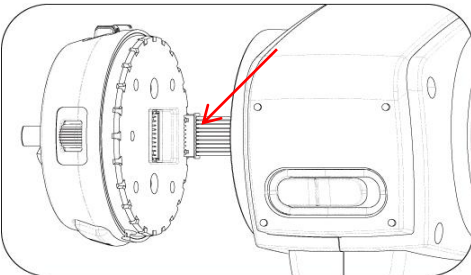

9. Plug in the other end of wire to wheel set.

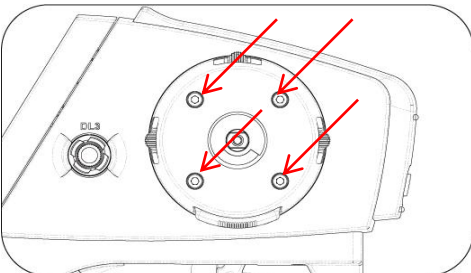

10. Screw in the 4 screws on the wheel set. Use the screws which were taken off in the Step 2.

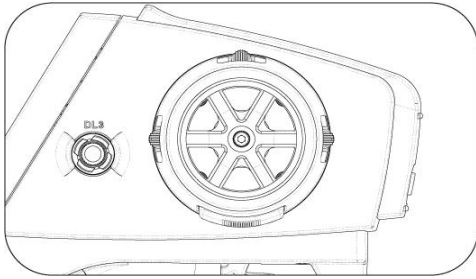

11. Assemble the wheel by driving the center screw.

2.2 How to Change the Wheel Angle

The wheel angle of TS401 with the adapter for wheel extension assembled can be modified for the user's preference.

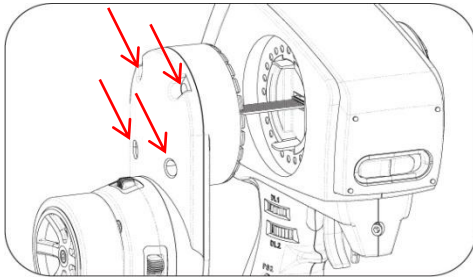

1. Take off the 4 screws on the adapter neck.

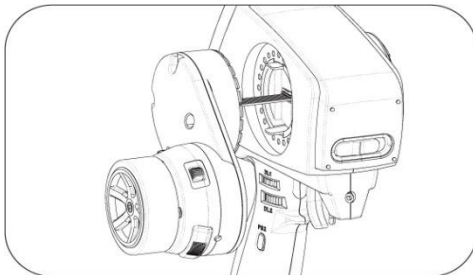

2. Pull the adapter softly and adjust the wheel angle to the desired direction. The angle can be adjusted by every 15°.

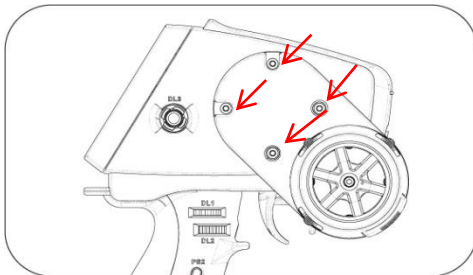

3. Mount the adapter to the transmitter body keeping the adjusted angle and drive the 4 screws on the adapter neck.

2.3 How to Change the Wheel Position for the Left-handed Use

The default set of TS401 wheel is for the right-handed use. The wheel position can be easily modified for the left-handed persons.

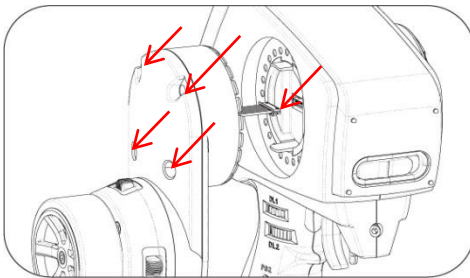

1. Take off the 4 screws on the adapter neck and disconnect the wire.

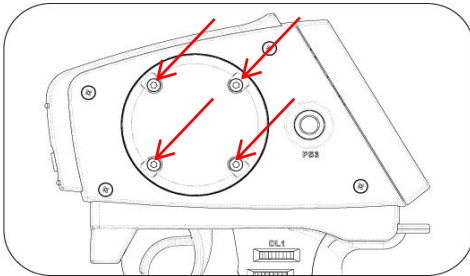

2. Detach the empty wheel cover on the left side of transmitter by taking off the 4 screws and attach it to the right side.

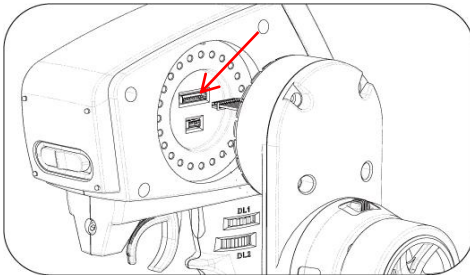

3. Connect the wire to the transmitter body.

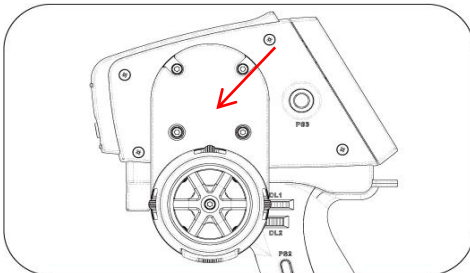

4. Connect the adapter for wheel extension by driving the 4 screws.

<Note>

To remove the adapter from the wheel position, refer to the steps in 2.1 (How to remove and attach the adapter for wheel extension).

3. Functions and Description of Buttons

3.1 Edit Buttons

There are 7 Edit Buttons such as Navigation (**UP** and **DOWN/ Left** and **RIGHT** and **SET**), **MENU** and **BACK**. Edit Buttons have two type of Modes: Normal or Edit. Normal Mode is for selecting items, and Edit Mode is for saving the edited values.

Button Name	Description
MENU	<ul style="list-style-type: none"> ▪ In the welcome screen, the MENU is used to move to the menu ▪ In the edit mode, the MENU is used to change the edited value to the default value.
BACK	<ul style="list-style-type: none"> ▪ The BACK is used to move to previous step in the menu. ▪ In the edit mode, the BACK is used to move to the normal mode without saving.
UP	<ul style="list-style-type: none"> ▪ In the normal mode, the UP is used to move to the upper step. ▪ In the edit mode, the UP is used to increase the edit value.
DOWN	<ul style="list-style-type: none"> ▪ In the normal mode, the DOWN is used to move to the sub-step. ▪ In the edit mode, the DOWN is used to decrease the edit value.
LEFT	<ul style="list-style-type: none"> ▪ In the normal mode, the LEFT is used to move to the left item. ▪ In the edit mode, the LEFT is used to decrease the edit value.
RIGHT	<ul style="list-style-type: none"> ▪ In the normal mode, the RIGHT is used to move to the right item. ▪ In the edit mode, the RIGHT is used to increase the edit value.
SET	<ul style="list-style-type: none"> ▪ In the welcome screen, the SET is used to move to the Menu. ▪ In the edit mode, the SET is used to change the edit value to the default value.

3.2 Trim Buttons

There are 3 Trim Buttons such as **DT1**, **DT2** and **DT3**.

Button Name	Description
DT1	<ul style="list-style-type: none"> ▪ Press the DT1 to the left direction to decrease the setting value of the allocated function. ▪ Press the DT1 to the right direction to increase the setting value of the allocated function.
DT2	<ul style="list-style-type: none"> ▪ Press the DT2 to the left direction to decrease the setting value of the allocated function. ▪ Press the DT2 to the right direction to increase the setting value of the allocated function.
DT3	<ul style="list-style-type: none"> ▪ Press the DT3 to the left direction to decrease the setting value of the allocated function. ▪ Press the DT3 to the right direction to increase the setting value of the allocated function.

3.3 Dial Buttons

There are 3 Dial buttons such as **Dial 1**, **Dial 2** and **Dial 3**.

Button Name	Description
Dial 1	<ul style="list-style-type: none"> ▪ Turn the Dial 1 left to decrease the setting value of the allocated function. ▪ Turn the Dial 1 right to increase the setting value of the allocated function.
Dial 2	<ul style="list-style-type: none"> ▪ Turn the Dial 2 left to decrease the setting value of the allocated function. ▪ Turn the Dial 2 right to increase the setting value of the allocated function..
Dial 3	<ul style="list-style-type: none"> ▪ Turn the Dial 3 left to decrease the setting value of the allocated function. ▪ Turn the Dial 3 right to increase the setting value of the allocated function.

3.4 Push Switches

There are 3 Push Switch such as **PS1**, **PS2** and **PS3**.

Switch Name	Description
PS1	Press the PS1 to activate the allocated function of the switch.
PS2	Press the PS2 to activate the allocated function of the switch..
PS3	Press the PS3 to activate the allocated function of the switch. PS3 has On status and Off status.

4. Function Map (Quick Menu/All Menu)

4.1 Quick Menu

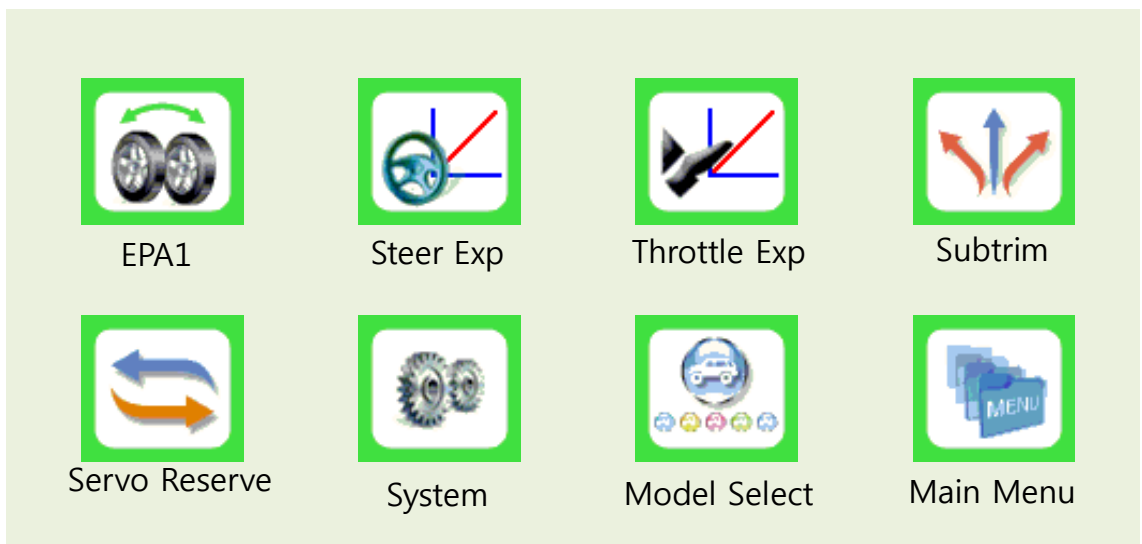

4.2 All Menu

Top	Depth 1	Depth 2
Menu	Model	Model Select
		Model Name
		Model Copy
		Model Reset
	Subtrim	
	Dual Rate	
	EPA 1	
	EPA 2	
	Exponential	Steer Exponential
		Throttle EXP
	Reverse	
	Bind Receiver	
	Switch Select	Switch
		Dial
		Trim Switch
	Speed	Steer Speed
		Throttle Speed
	Brake	
	Monitor	
	Adjust	
	Timer	
	Lap List	
	Edit Banner	
	System	
	Advanced	Throttle Mode
		ABS
		TH-Acceleration
AT-Start		
Idle-Up		
ATL		
AUX CH Position		
Boat Mode		
Prog Mix		

5. Description of Functions

5.1 Model

5.1.1 Model Select

Transmitter can save up 20 different models. Select your model(s) in the menu displayed below.

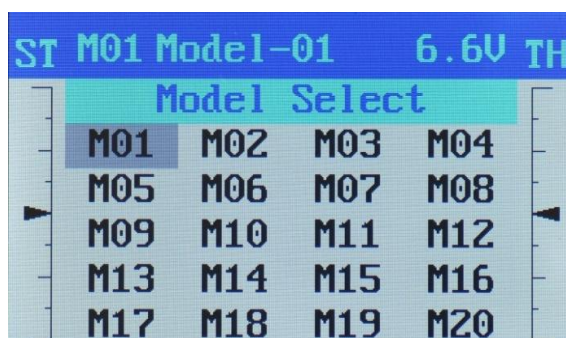

■ How to Set

Move to the model number by using the directional (**LEFT/ RIGHT/ UP/DOWN**). Press the **SET** to select the model.

5.1.2 Model Name

Use the "Model Name" function to change the model name. The model name can be created with a maximum of 20 characters including capital and lower case letters, numbers and symbols. (!"#\$\$%&'()*+,-./:;<=>?[W]^_`{|}~).

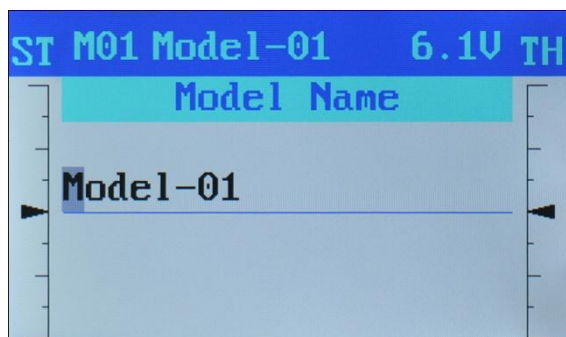

■ How to Set

Move to the location you want to change by using the **LEFT** and the **RIGHT**. Press the **SET** to display the text box (the cursor will automatically move to your selection).

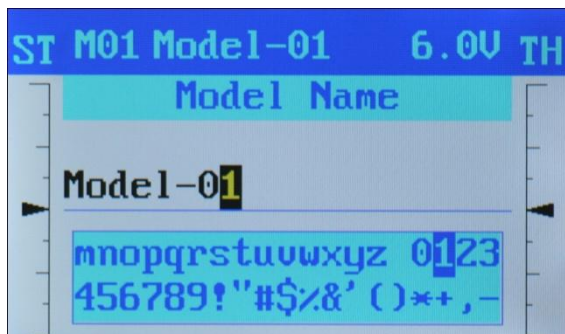

Use the directional (**LEFT/RIGHT/UP/DOWN**) to select a character and press the **SET** to confirm. Repeat to change other characters as needed.

5.1.3 Model Copy

Use the Model Copy function to copy the data value of your selected model onto another model.

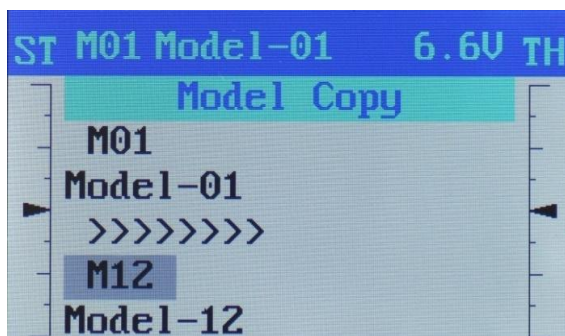

■ How to Set

Select the model you want to copy in the "Model Select" menu. Use the **UP/DOWN** to select the designated model. Press the **SET** and the designated model will be copied and moved to the previous menu.

Select the "Yes" and press the **SET** to initialize the current model's input values (DR, ATL, EPA, ST-EXP, TH-EXP, Brake, etc.) to the default value.

5.1.4 Model Reset

Use the "Model Reset" to initialize the current model's input values (DR, ATL, EPA, ST-EXP, TH-EXP, Brake, etc.).

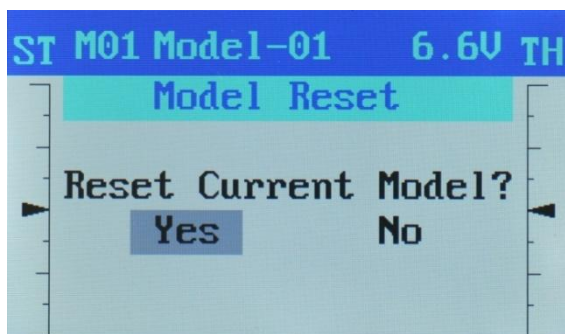

■ How to Set

Select the model you want to reset in "Model Select" menu by selecting the "Model Reset" menu. Select "Yes" and press **SET** to reset current model's input value to the default value.

5.2 Subtrim

In case the control arm of the servo is not neutral or centered, use the "Subtrim" to adjust the servo horn left or right to make it centered.

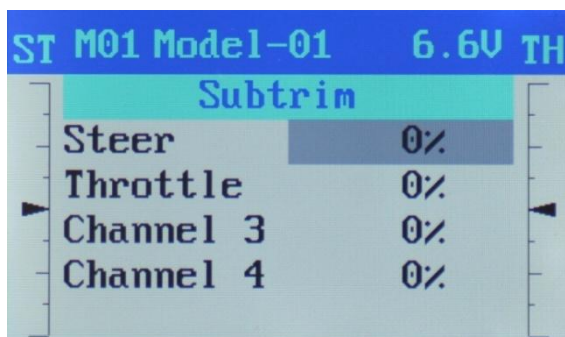

Adjust the Servo movement with the Steer channel so that the steering can be in a neutral position. The available setting range is from L 100%(left) to R 100% (right). Use the "Throttle channel" to make the servo control the engine throttle at neutral. The available setting range is from F 100% (accelerator) to B 100% (brake). The aux channels (channel 3 and 4) have the available settings ranging from -100% to 100%. The default value is 0%.

■ How to Set

Use the **UP/DOWN** to move to the preferred channel, then press the **SET**. Change the trim value with **LEFT** and **RIGHT**. Adjust subtrim value to center the servo at the neutral position. After the adjustment, press the **SET** to save the changed value.

5.3 Dual Rate

Adjust the maximum end point of the steer servo. The dual rate is allocated in the Dial Switch No. 1 on the grip handle. Other Dial Switches (No. 2 or No. 3) are also able to allocate the angle value.

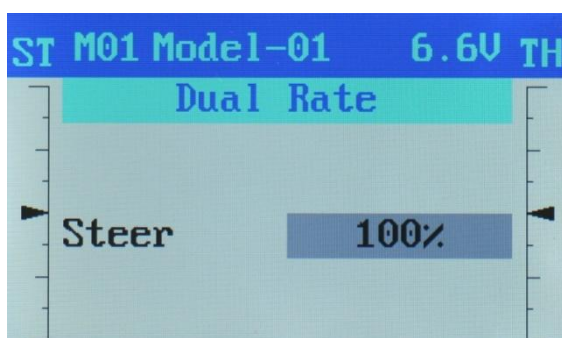

■ How to Set

Press the **SET**, then change the value with the **LEFT** or **RIGHT**. Press the **SET** to save the changed value. Steer dual rate has an adjustable range from 0% to 100%. Default value is 100%.

5.4 EPA 1

Use EPA 1 to set the maximum end point of Steer channel and Throttle channel.

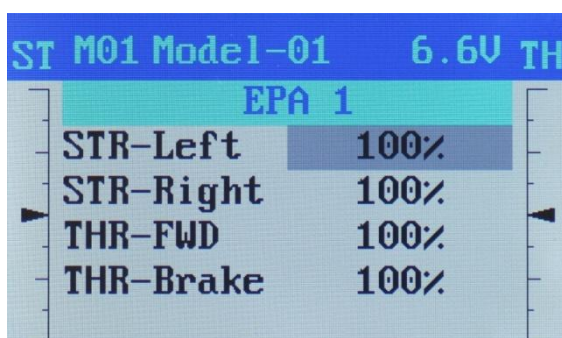

Use the "STR-LEFT" to set the maximum left end point of steer channel.
Use the "STR-RIGHT" to set the maximum right end point of steer channel.
Use the "THR-FWD" to set the maximum end point toward the forward direction of throttle channel.
Use the "THR-BRAKE" to set the maximum end point toward the brake direction of throttle channel.
The maximum end point has adjustable range from 50% to 120%, and the default value is 100%.

■ How to Set

Use the **UP/DOWN** to move preferred channel and press the **SET**.
Change trim value with the **LEFT** and the **RIGHT**. After adjustment, press the **SET** to save the changed value.

5.5 EPA 2

Set the maximum end point of the aux channels (CH3, CH4).

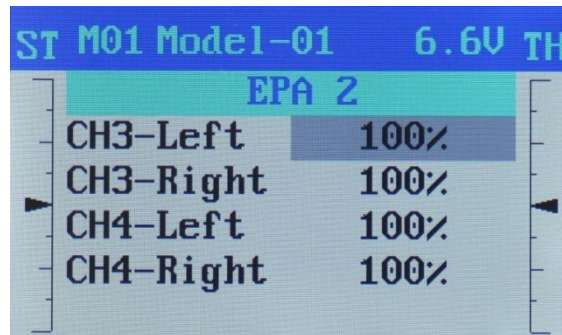

Use the "CH3-LEFT" to set the maximum left end point of 3rd channel.
Use the "CH3-RIGHT" to set the maximum right end point of 3rd channel.
Use the "CH4-LEFT" to set the maximum left end point of 4th channel.
Use the "CH4-RIGHT" to set the maximum right end point of 4th channel.
The maximum end point has an adjustable range from 50% to 120% and default value is 100%.

■ How to Set

Use **UP/DOWN** to move to preferred channel, then press **SET**. Change trim value with **LEFT** and **RIGHT**.

After adjustment, press **SET** to save the changed value.

5.6 Exponential

5.6.1 Steer Exponential

Use the "Steer Exponential" to adjust the movement in neutral. If the steer exponential value is less than "0", the response of control will be slower.

In contrast, if the steer exponential value is greater than "0", the response of control will be faster.

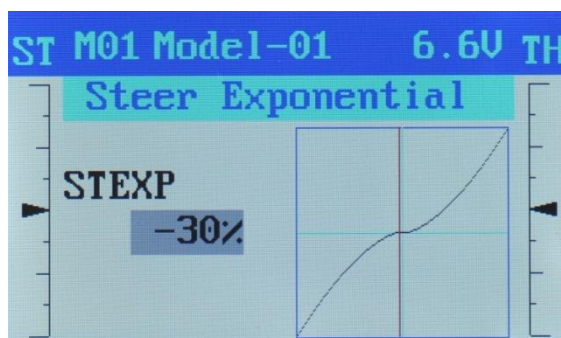

The Exponential value has an adjustable range from -100% to 100% and default value is 0%.

■ How to Set

Press the **SET** and change the exponential value with the **LEFT** and **RIGHT**. If the graph has preferred curve, press the **SET** to save the adjusted value. The movement of steer would be changed according to the curve setting value.

5.6.2 Throttle EXP

Use the Throttle EXP to adjust the movement of throttle (Accelerator/ Brake) channel. The direction of accelerator and brake is separately adjustable. The channel movement of accelerator direction is adjustable as following 3 types.

- EXP: Adjust the sensitivity of movement in neutral by using exponential curve.
- VTR: Put the curve point between the neutral point and the highest throttle point to move in a different straight line before and after the curve point.
- CRV: There are 3 designated curve points between the neutral point and the highest point. (0~25%, 25~50%, 50~75%, 75~100%). Set different movements between the curve points.

Brake direction is available to adjust by using the EXP only. If the EXP value is less than "0", the response of control in neutral would be slower. In contrary, the EXP value is greater than "0", the response of control in neutral would be faster.

■ How to Set

- EXP: Select EXP by pressing the **SET** on TYPE. Press the **DOWN** to move to FWD.
- FWD: Press the **SET** on FWD and set the EXP values by using the **LEFT** and **RIGHT**, After adjustment, press the **SET** once more to save the changed value. EXP value has adjustable range between -100~100%, and default value is 0%.
- BRK: Press the **DOWN** to move to BRK. Press the **SET** on the "BRK" and set the "EXP" value by using the **LEFT** and the **RIGHT**. After adjustment, press the **SET** once again to save the changed Value. The EXP value has an adjustable range between -100~100% and default value is 0%.

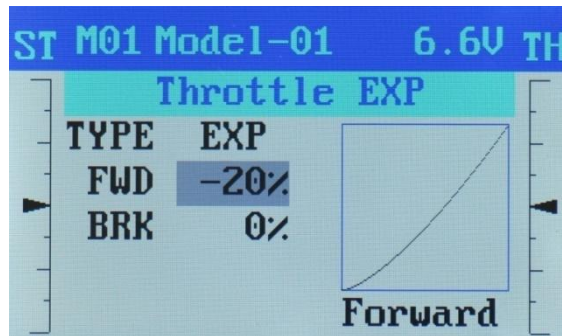

- VTR: Press the **SET** on TYPE and select VTR. Press the **DOWN** to move to FWD.
- FWD: Press the **SET** on FWD, and set the trigger point value by using **LEFT** and **RIGHT**. Press the **SET** to save the changed value.
- TGP: Press **DOWN** to move to TGP. Press the **SET** on TGP, and move the trigger point by using the **LEFT** and the **RIGHT**. After adjustment, press the **SET** once again to save the changed value.
- BRK: The setting method of Brake direction is same with that of EXP brake direction. Please refer to the setting method of EXP brake direction.

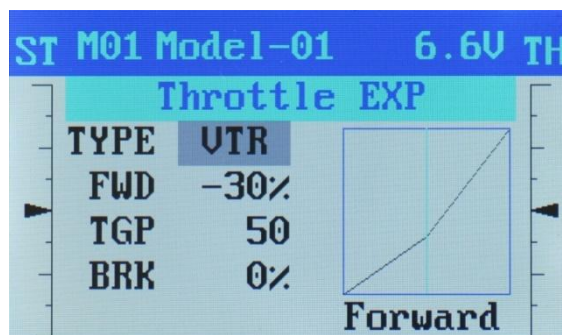

- CRV: Press the **SET** on TYPE and select CRV. Press the **DOWN** to move to FWD.

Set FWD for each 3 (1,2,3) trigger points. Press the **SET** on "1:" and adjust the value by using the **LEFT** and **RIGHT**. After adjustment, press the **SET** to save the adjusted value. Press the **DOWN** to move to "2:" and "3:" Setting methods of "2:" and "3:" are the same as "1:".

The setting method of the Brake direction is the same as the EXP brake direction. Please refer to the setting method of EXP brake direction.

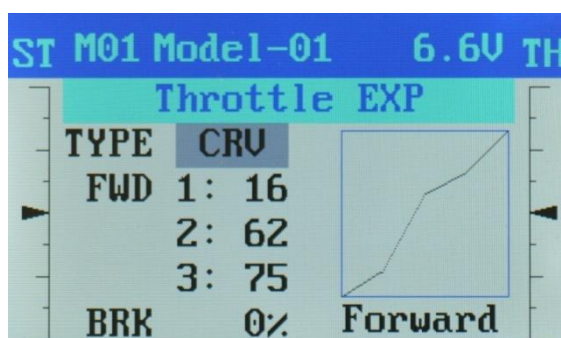

5.7 Reverse

Use Reverse in case that the movement of each channel servo is reversed. If the movement is in the right direction, set the value as "Normal" (default value), and if the movement is in the opposite direction, set the value as "Reverse". The default value is Normal.

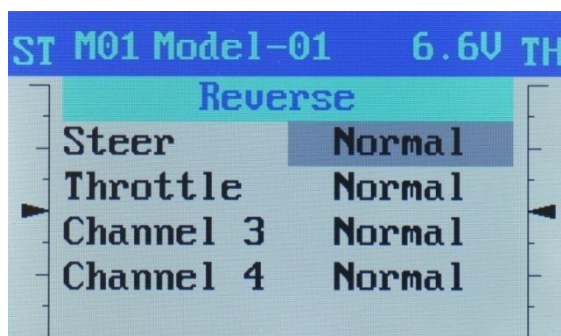

Move to the preferred channel by using the **UP/DOWN** and press the **SET**. Press the **LEFT** or **RIGHT** to select Normal or Reverse. Press the **SET** to save the adjusted value.

5.8 Bind Receiver

This function is used to bind a new receiver to the transmitter.

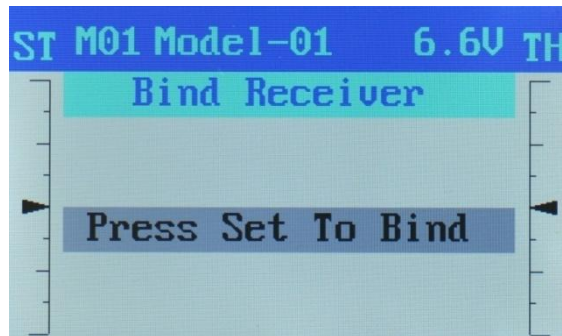

■ How to Set

Turn on the power to receiver, press and hold down the ID button of the receiver until it goes into binding mode. Press the **SET** on the transmitter to go into binding mode with the message "Wait until Bound" is displayed on the LCD screen.

When the transmitter and receiver successfully bind, the message "Successfully Bound" is displayed on the screen. If the transmitter and the receiver fail to bind, the message "Failed to Bind" is displayed on the screen. In case that a failure occurs, wait a short period of time before attempting to bind again.

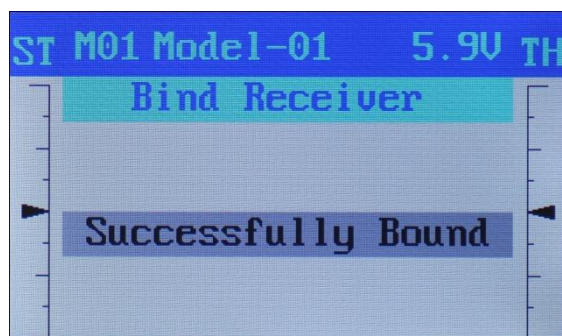
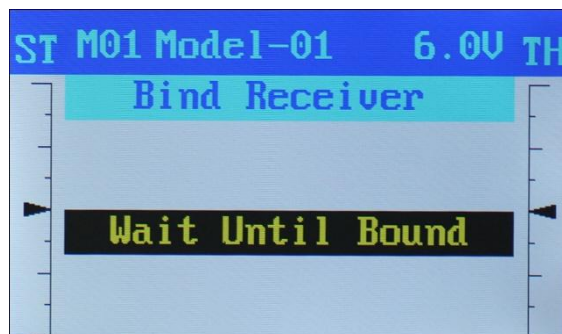

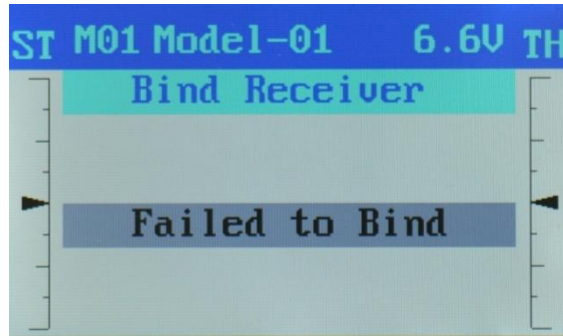

 **Caution**

If the RF transmitter is set as OFF, the transmitter does not go into the binding mode with the message "Enable RF First" displayed on the screen. In this case, go to the System Menu and set the Radio TX as On for binding.

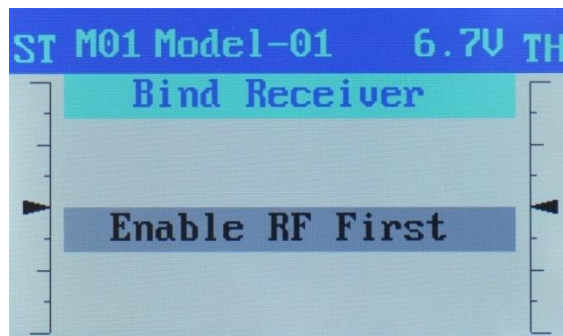

5.9 Selection of Switch

5.9.1 Push Switch

There are 3 push switches on the transmitter: **PS1**, **PS2** and **PS3**. The functions shown in the below table can be assigned to each push switch. The default setting of push switches is OFF.

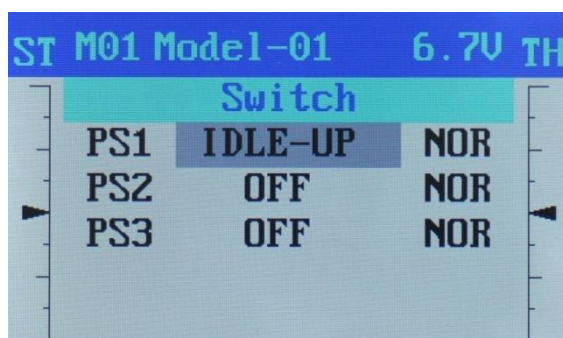

The table shows the functions that can be assigned to the push switches.

Item	Functions
OFF	Not Assigned
PRESET	Enables Auto Start
NT-BRAKE	Enables Neutral Brake
ABS.CH2	Enables ABS over Channel 2
ABS.CH3/4	Enables ABS over Channel 3/4
IDLE-UP	Enables Idleup
PROG MIX1	Enables Program Mix 1
PROG MIX2	Enables Program Mix 2
CH3	Channel 3 Value
CH4	Channel 4 Value
LAP START	Starts Timer
LAP RESET	Resets Timer

■ How to Set

In order to assign a function to PS1, press the **SET** and move to the preferred function using the **LEFT** and **RIGHT** and press the **SET** again.

Move to the right side of screen by pressing the **RIGHT** to set the motion types between Normal and Alternative.

How to assign functions to PS2 and PS3 is same as that to PS1. But note that PS3 has a Normal motion and Reverse motion.

5.9.2 Dial Switch

There are 3 dial switches on the transmitter: DL1, DL2 and DL3. These functions shown in the table below can be assigned to each dial switch. The default setting of DL1 is TRMT, DL2 is EXPF and DL3 is OFF.

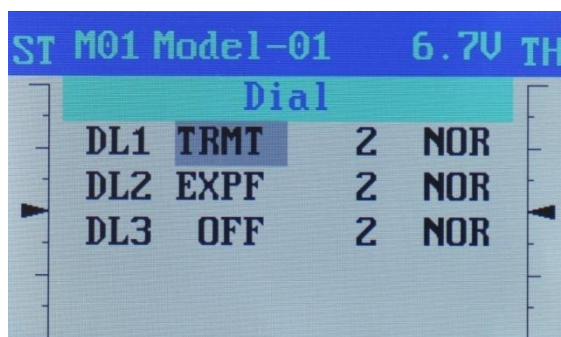

The following table shows the functions that can be assigned to the dial switches.

Item	Functions
OFF	Not Assigned
D/R	Steer Dual Rate
ATL	ATL
EXPS	Steer Exponential
EXPF	Throttle Exponential (Forward side)
EXPB	Throttle Exponential (Brake side)
EXP3	Brake Exponential for Channel 3
EXP4	Brake Exponential for Channel 4
SPTn	Steer Speed (Turn side)
SPRn	Steer Speed (Return side)
AB.P	ABS function (Return amount)
ABSD	ABS function (Delay)
CYCL	ABS function (cycle speed)
ACCF	Throttle acceleration (Forward side)
ACCB	Throttle acceleration (Brake side)
THS1	Throttle speed (All/Low)
THS2	Throttle speed (MID)
THS3	Throttle speed (High)
TRMS	Steer Trim
TRMT	Throttle Trim
3CH	Channel 3
4CH	Channel 4

Item	Functions
SBT1	Sub trim (CH1)
SBT2	Sub trim (CH2)
SBT3	Sub trim (CH3)
SBT4	Sub trim (CH4)
IDLE	Idleup
TL13	Tilt Mixing (1→3)
TL31	Tilt Mixing (3→1)
PM1A	Program Mix 1 (LEFT/FWRD/UP sides)
PM1B	Program Mix 1 (RIGHT/BRAKE/DOWN sides)
PM2A	Program Mix 2 (LEFT/FWRD/UP sides)
PM2B	Program Mix 2 (RIGHT/BRAKE/DOWN sides)
B3RT	Channel 3 brake mixing rate
B30	Channel 3 brake mixing delay
B3AP	Channel 3 brake mixing ABS return amount
B3AD	Channel 3 brake mixing ABS delay
B4RT	Channel 4 brake mixing rate
B40	Channel 4 brake mixing delay
B4AP	Channel 4 brake mixing ABS return amount
B4AD	Channel 4 brake mixing ABS delay
B34RT	Brake mixing rate for both channel 3 and channel 4

■ How to Set

In order to assign a function to DL1, press the **SET** and move to the preferred function using the **LEFT** and **RIGHT**. Press the **SET** to save the selected function.

Move to the right side of screen by pressing the **RIGHT** to set the change unit per click. The default value of clicks is set at 2, which means that one click of the switch increases or decreases the relevant value by 2.

Move to the right side of screen by pressing the **RIGHT** to set the motion direction of dial between Normal and Reverse. The default setting of dial direction is Normal.

To assign functions, setting the change unit per dial click and setting the motion direction for DL2 and DL3 are the same as mentioned for DL1.

5.9.3 Trim Switch

There are 3 digital trim switches on the transmitter: **DT1**, **DT2** and **DT3**. The preferred functions can be assigned to each trim switch. The default setting of **DT1** is TRMS, **DT2** is D/R and **DT3** is EXPS.

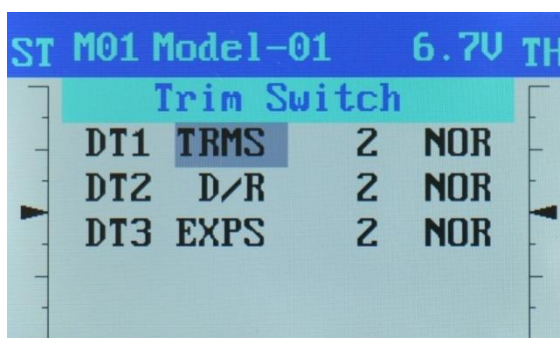

Trim Switch			
DT1	TRMS	2	NOR
DT2	D/R	2	NOR
DT3	EXPS	2	NOR

All the functions for the dial switches as shown in the table of the Dial Switch section can be assigned to the trim switches.

■ How to Set

In order to assign a function to **DT1**, press the **SET**, move to the preferred function using the **LEFT** and the **RIGHT** and the press the **SET** to save the selected function.

Move to the right side of screen by pressing the **RIGHT** to set the change unit per pressing.

The default value of change per click is 2, which means that one press of the trim switch increases or decreases the relevant value by 2.

Move to the right side of screen by pressing the **RIGHT** to set the motion direction of trim switch between Normal and Reverse. The default setting of motion direction is Normal.

How to assign functions, how to set the change unit per pressing and how to set the motion direction for **DT2** and **DT3** are same as those for **DT1**.

5.10 Speed

5.10.1 Steer Speed

Abrupt steering may cause excessive or insufficient rotation of vehicle and possibly cause deceleration. To prevent unexpected results, it is suggested to adjust the reaction speed of the steering.

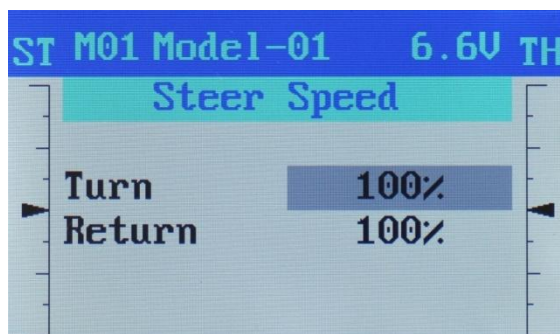

■ How to Set

Select whether to adjust the value of start turn direction or to adjust the value of rotation return direction, and then press the **SET**. Use the **LEFT** and the **RIGHT** to change the value. Press the **SET** to save the adjusted value. Delay occurs to the movement of steering according to the set value.

5.10.2 Throttle Speed

In case of sudden start on a slippery road, the acceleration may not be as smooth due to lack of traction of the vehicles wheels. The start can be smoother and the power consumption may be reduced if you use this Throttle Speed function. The speed can be adjusted in 3 ranges.

● Speed 1

Speed is set as the whole direction of throttle acceleration is one range.

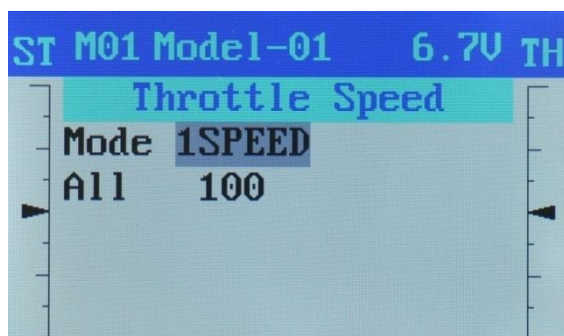

■ How to Set

Select Speed 1 in the Mode. Move to All by using the **DOWN** and press the **SET**. The value can be changed using the **LEFT** and the **RIGHT**. After finishing the adjustment, press the **SET** to save the changed value. The speed changes according to the setting value of throttle.

● Speed 2

Speed is set as the direction of throttle acceleration is divided into the low range and the high range on the basis of a trigger point.

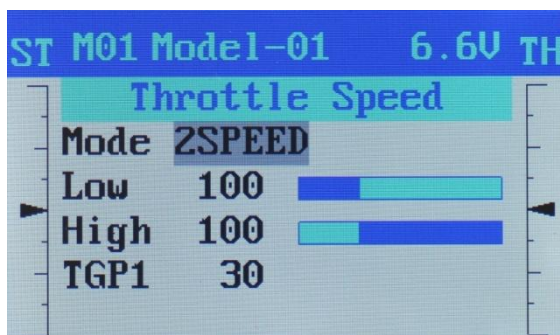

■ How to Set

Select Speed 2 in the Mode. Move to Low using the **DOWN** and press the **SET**. Change the value in the Low range using the **LEFT** and the **RIGHT**. After finishing the adjustment, press the **SET** to save the changed value. The speed in the Low range of throttle changes according to the setting value.

Move to High using the **DOWN** and press the **SET**. Change the value in the High range using the **LEFT** and the **RIGHT**. After finishing the adjustment, press the **SET** to save the changed value. The speed in the High range of throttle changed according to the setting value.

Move to TGP 1 using **DOWN** and press the **SET**. Change the value of the boundary point between the Low range and the High range. After finishing the adjustment, press the **SET** to save the changed value.

● Speed 3

Speed is set as the direction of throttle acceleration is divided into the low range, the mid range and the high range on the basis of two trigger points.

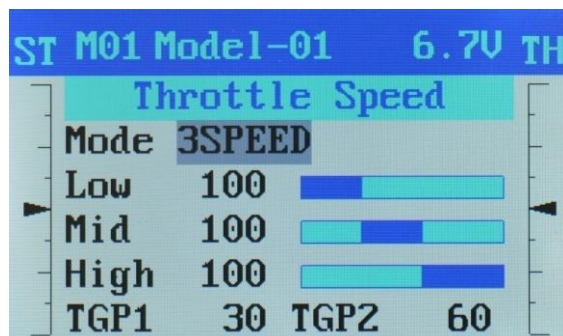

■ How to Set

Select Speed 3 in the Mode. Move to Low using the **DOWN** and press the **SET**. Change the value in the Low range using the **LEFT** and **RIGHT**. After finishing the adjustment, press the **SET** to save the changed value. The speed in the Low range of throttle changes according to the setting value.

Move to MID using the **DOWN** and press the **SET**. Change the value in the MID range using the **LEFT** and **RIGHT**. After finishing the adjustment, press the **SET** to save the changed value. The speed in the MID range of throttle changes according to the setting value.

Move to High using the **DOWN** and press the **SET**. Change the value in the High range using the **LEFT** and **RIGHT**. After finishing the adjustment, press the **SET** to save the changed value. The speed in the High range of throttle changes according to the setting value.

Move to TGP 1 using **DOWN** and press the **SET**. Change the value of the boundary point between the Low range and the MID range. After finishing the adjustment, press the **SET** to save the changed value. Move to TGP 2 using the **DOWN** and press the **SET**. Change the value of the boundary point between MID range and the High range. After finishing the adjustment, press the **SET** to save the changed value.

5.11 Brake

This function is used to operate the brake system of front wheels and the brake system of rear wheels separately. The brake of rear wheels can be connected to the Ch. 2 and the brake of front wheels can be connected to the Ch. 3 or Ch. 4. Brake mixing can be applied to Ch. 3 and Ch. 4 respectively. If the mixing function is inhibited (INH), the value setting cannot be done and will be blocked by the mark '----'.

ST M01 Model-01		6.7V TH	
Brake			
	CH3	CH4	
Mode	INH	INH	
Rate-Each	----	----	
Rate-Comm	----		
Brake-EXP	----	----	

■ How to Set

The default setting for this function is INH. Move to the channel to be set using the **LEFT** and the **RIGHT** in the Mode. Press the **SET** to change the mode into ACT using the **RIGHT** and press the **SET** again to activate the selected channel. The figure below shows that Ch. 3 is activated.

ST M01 Model-01		6.6V TH	
Brake			
	CH3	CH4	
Mode	ACT	INH	
Rate-Each	100	----	
Rate-Comm	100		
Brake-EXP	0	----	

Move to the RATE-EACH using the **DOWN** to set the mixing ratio. The range of mixing ratio is 0 to 100. The default value is 100.

Move to the RATE-COM using the **DOWN** to set the mixing ratio. The range of mixing ratio is 0 to 100. The default value is 100. As the RATE-COM setting affects Ch. 4, it is used to apply the brake mixing ratio both to Ch. 3 and Ch. 4.

Move to the Brake-EXP using the **DOWN** to set the exponential value. The range of exponential value is -100 to 100. The default value is 0. When the value is negative (-), the motion around the neutral position becomes dull. When the value is positive (+), the motion around the neutral position becomes sensitive.

ST M01 Model-01		6.7V TH	
Brake			
	CH3	CH4	
Brake-DLY	0	---	
STM-Left	100	---	
STM-Right	100	---	

Move to the Brake-DLY in the next page by pressing the **DOWN** on Brake-EXP. Press the **SET** on Brake-DLY to set the brake delay time. The brake delay time can be set to the front or rear brake.

Move to the STM-LEFT using the **DOWN** to set the steering mixing value. It is to set the change the mixing value ratio when the steering wheel is turned toward the left. The range of mixing ratio is 0 to 100. The default value is 100.

Move to the STM-RIGHT using the **DOWN** to set the steering mixing value. It is to set the change the mixing value ratio when the steering wheel is turned toward the right. The range of mixing ratio is 0 to 100. The default value is 100.

ST M01 Model-01		6.6V TH	
Brake			
	CH3	CH4	
ABS-Mode	INH	---	
ABS-ABP	---	---	
ABS-DLY	---	---	

Move to ABS-Mode in the next page by pressing the **DOWN** on the STM-RIGHT. The default setting of ABS-Mode is INH. In the INH state, the mixing value cannot be set because the slot for value setting is blocked by the mark '---'. In order to activate the ABS-Mode, change INH to ACT first.

ST M01 Model-01		6.7V TH	
Brake			
	CH3	CH4	
ABS-Mode	ACT	---	
ABS-ABP	50	---	
ABS-DLY	0	---	
	(Off)		

Move to the ABS-ABP using the **DOWN** to set the brake return amount value. The value range is 0 to 100. The default value is 50. When the value is 0, no brake return is carried out, which means ABS function does not work. When the value is 50, the brake return is carried out to the 50% position of trigger point. When the value is 100, the brake servo performs the brake return to the neutral position.

Move to the ABS-DLY using the **DOWN** to set the brake delay time value. The value range is 0 to 100. The default value is 100. When the value is 0, there is no brake delay. When the value is 50, ABS brake starts around 0.75 second after the brake is on. When the value is 100, ABS brake starts around 1.5 seconds after the brake is on.

5.12 Monitor

This function is to display the position of servo which is detected by the transmitter. The 4 channels are displayed in order. Ch.1 is for steering, Ch.2 is for throttle, and Ch.3 and Ch.4 are in reserve.

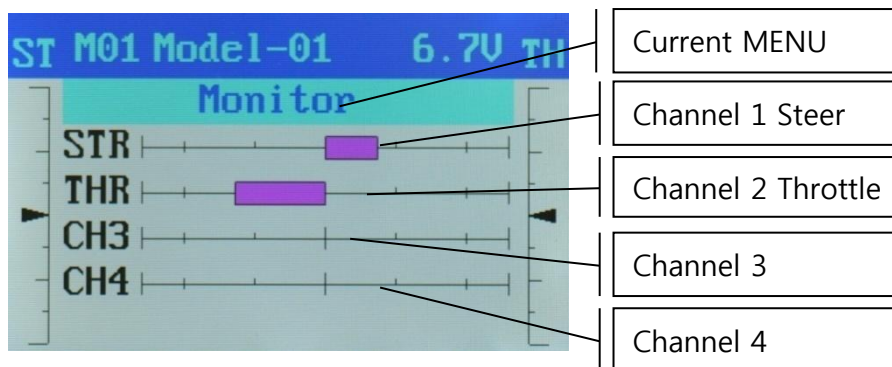

5.13 Adjust

In case that the steering and the throttle weaken or their neutral values go wrong due to some mechanical issues, the motions can be calibrated by resetting the neutral position, minimum value and maximum value using this adjustment function. The setting items for adjustment are Steer and Throttle.

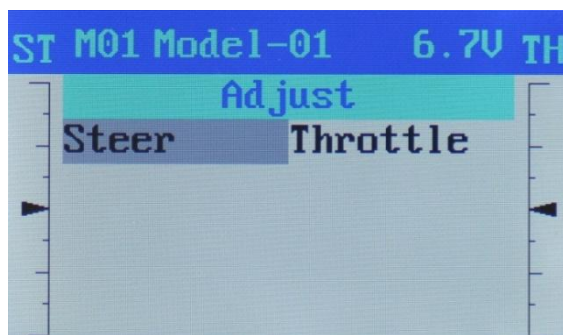

■ How to Set

Select Steer. Put the steering wheel on the neutral position and press the **SET**.

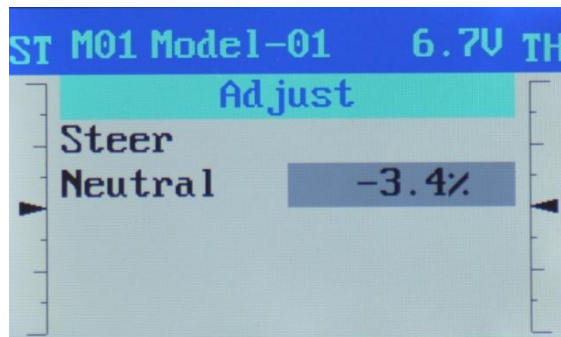

Turn the steering wheel to the left end and to the right end to make the maximum values recognized.

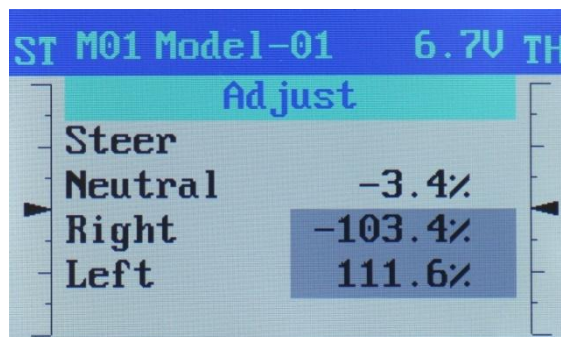

Press the **SET** to save the neutral position value, the left maximum value and the right maximum value.

Select Throttle using the **RIGHT**. Put the throttle on the neutral position and press the **SET**.

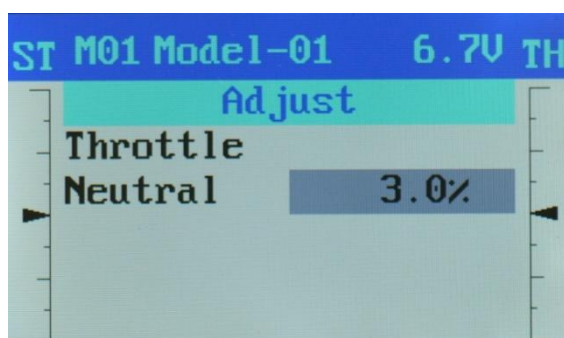

Move the throttle to the forward end and to the backward end to make the maximum values recognized.

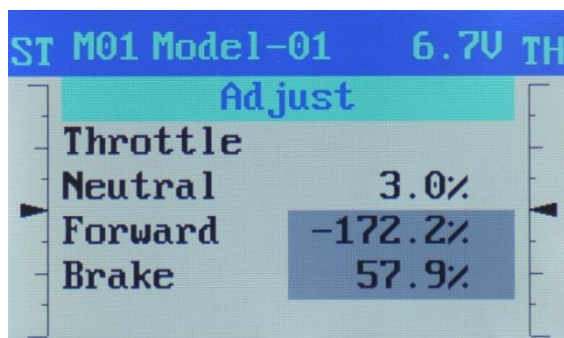

Press the **SET** to save the neutral position value, the Forward maximum value and the Brake maximum value.

5.14 Timer

4 different types of timer are available. (UP, DOWN, LAP, LAP Navigate)

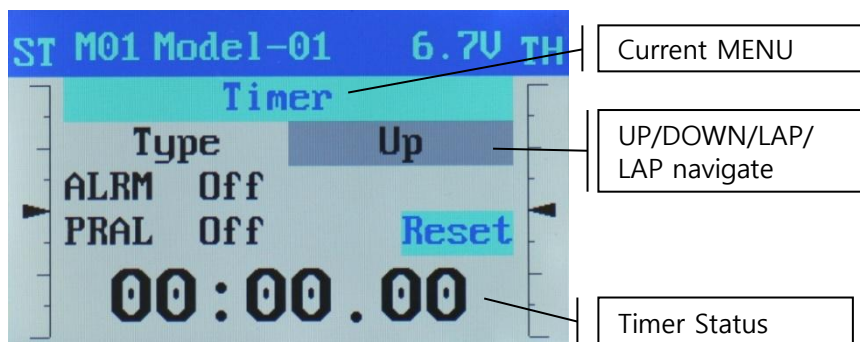

Select TYPE first and select the type of timer using the **UP/DOWN**.

Timer has 3 kinds of mode.

- RESET: The timer value is "0" which means timer is not activated.
- RUN : The timer is activated.
- STOP : the timer is suspended for a while. In this case, the timer value may not be "0".

● UP Timer

The timer's range is 0 to 99.9999 minutes.

Alarms can be set in 1 minute increments.

Pre-alarms can be set in 1 second increments.

When the timer reaches the set alarm time, alarm sound is made.

When a pre-alarm is set, the warning sound beeps for the set pre-alarm period before the timer reaches the set alarm time.

When the timer reaches the set alarm time, alarm sound is made.

If the user does not stop the timer even after alarm sound has been made, the warning sound beeps every one minute.

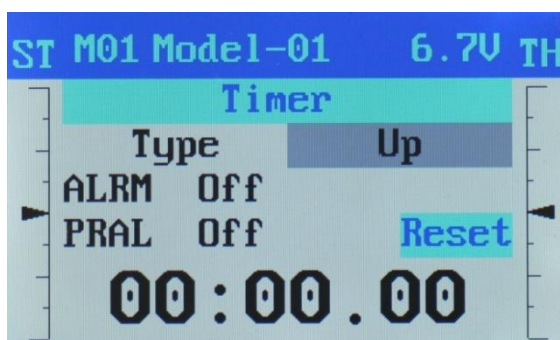

■ How to Set the Timer

Move to TYPE using the **UP/DOWN** and press the **SET**. Then, select UP and press the **SET**.

Move to ALRM using the **DOWN** and press the **SET**. Set the alarm time and press the **SET**.

The alarms can be set in 1 minute increments up to 99 minutes.
(e.g. OFF/1min./2min.~99min.)

Move to PRAL using the **DOWN** and press the **SET**. Set the pre-alarm and press the **SET**.

The pre-alarms can be set in 1 second increments up to 99 seconds.
(e.g. OFF/1sec./2sec.~99sec.)

● FUEL DOWN Timer

The time on the timer is decreased from the set alarm time to "0".

When the timer reaches "0", the alarm sound is made.

If the user does not stop the timer, the time continues to decrease.

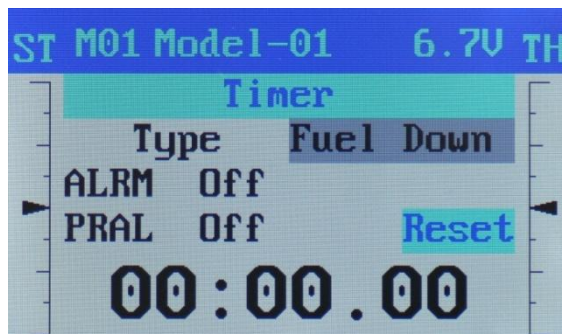

■ **How to Set the Timer** (Same with that of UP Timer)

Move to TYPE using the **UP/DOWN** and press the **SET**. Then, select PUEL Down and press the **SET**.

Move to ALRM using the **DOWN** and press the **SET**. Set the alarm time and press the **SET**.

The alarms can be set in 1 minute increments up to 99 minutes. (e.g. OFF/1min./2min.~99min.)

Move to PRAL using the **DOWN** and press the **SET**. Set the pre-alarm and press the **SET**.

The pre-alarms can be set in 1 second increments up to 99 seconds. (e.g. OFF/1sec./2sec.~99sec.)

● **LAP**

It is to record the LAP Time which is taken in driving the track one time. When pressing the switch, the time from the switch set point to the present. LAP TIME can be checked in the LAP List of Menu.

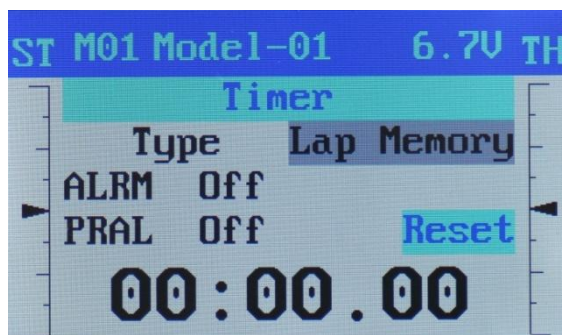

● LAP Navigate

Warning sound beeps on every set time.

The time range of warning sound can be selected from 1 second to 99 seconds in the NAVI menu.

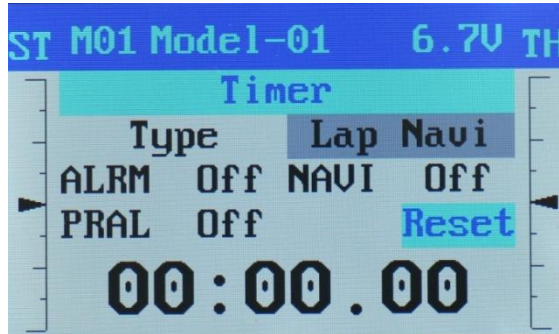

5.15 LAP List

LAP TIME can be checked.

Up to 100 LAP TIMES can be saved.

The LAP TIME up to 99 seconds can be saved in 0.01 second increments.

When pressing the **SET**, the currently selected LAP TIME is initialized to 0.00 second.

When pressing the **MENU**, all LAP TIMES are initialized to 0.00 second regardless the currently selected LAP TIME.

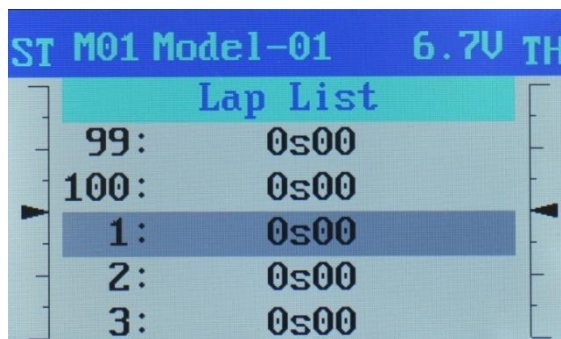

5.16 Edit Banner

The user can edit the top line banner on the welcome screen. Using capital or lower case letters and other marks (!"#\$\$%&'()*+,-./:;<=>?[W]^_`{|}~), 15 characters in maximum can be input. The default banner is Radiopost.

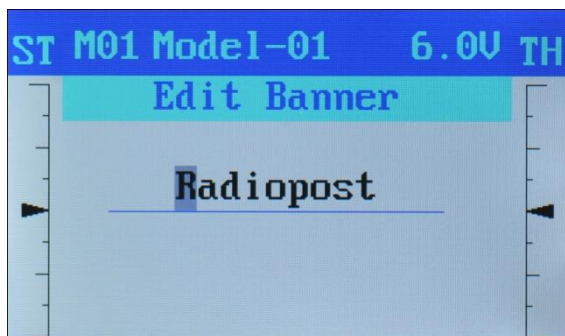

■ How to Set

Move to the place to be changed using the **LEFT** and the **RIGHT**. Press the **SET** to display the character box and use the navigation keys to move to different letters symbols in the cursor box.



Move to the character to be input using the direction buttons (**LEFT/RIGHT/UP/DOWN**) and press the **SET**. Change the other characters in the other positions in the same way.

5.17 System

The user can modify this System setting. The below table is the list of items which can be changed.

Item	Setting Values	Default Value
LCD backlight	Always On/30 sec./1 min./5 min.	1 min.
Buzzer	On/Off	On
Color	Blue/Blue2/Brown/Brown2/Green/Green2	Blue
Auto-Alert	Off/ 5Min/10Min/15Min/20Min	10MIN
Long Key Steps	1~100	2
Screen	Normal/Normal2/Timer/Timer2	Normal
Low Batt	4.1V~7.0V	4.5V
Radio Tx	On/Off	On

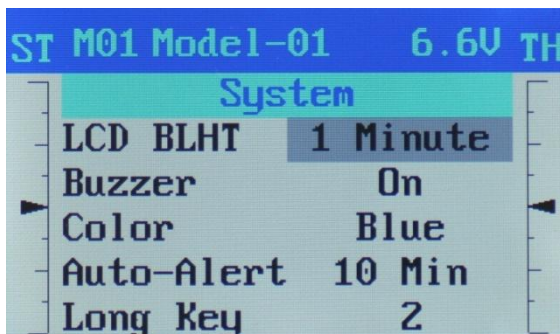

● LCD Backlight

This function is used to reduce battery consumption. If the user does not press the EDIT button for a specified period, the power of LCD screen turns off.

Setting Values	Description
Always On	The LCD screen is always on.
30 Seconds	Turned off after 30 seconds.
1 Minute	Turned off after 1 minute.
2 Minutes	Turned off after 2 minutes.
5 Minutes	Turned off after 5 minutes.

● Buzzer

This function is used to turn the buzzer sound on or off. It is useful when the user prefers to keep the buzzer silent. However, the alarm timer, the low battery warning and the auto-alert sounds are defaulted as "on" regardless of the user's discretion.

Setting Values	Description
On	The buzzer sounds.
Off	The buzzer does not sound.

● Color

Setting Values	Description
BLUE	The primary color is blue and the ground color is white.
BLUE2	The primary color is blue and the ground color is black.
BROWN	The primary color is brown and the ground color is white.
BROWN 2	The primary color is brown and the ground color is black.
GREEN	The primary color is green and the ground color is white.
GREEN2	The primary color is green and the ground color is black.

● Auto-Alert

This function creates a warning sound to let the user know that the transmitter has been idle with the power on.

Setting Values	Description
Off	No warning sound.
5 Minutes	Warning sound after 5 minutes.
10 Minutes	Warning sound after 10 minutes.
15 Minutes	Warning sound after 15 minutes.
20 Minutes	Warning sound after 20 minutes.

● Long Key

When the user presses the Edit buttons (**LEFT/RIGHT/UP/DOWN**) to change the setting values in the Menu, this function allows the user to change a unit to a larger or smaller value in increments of one, but may be edited to two, three, etc.

For example, if the LONG KEY STEP is 2, the setting value changes by 1 at first and then by 2 while the user keeps on pressing the **LEFT**. The setting range is 1 to 100. The default value is 2.

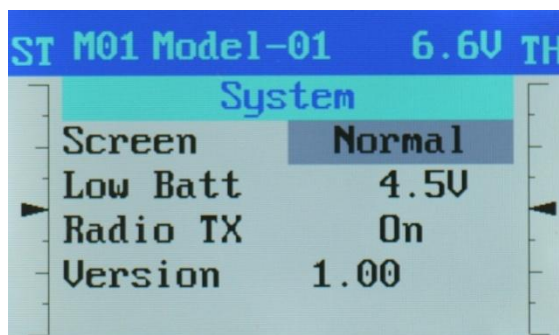

● Screen

Setting Values	Description
Normal	Basic welcome screen with the logo.
Normal 2	Basic welcome screen with the logo on which the box-type trim bar is applied.
Timer	Basic welcome screen with the timer.
Timer 2	Basic welcome screen with the timer on which the box-type trim bar is applied.

● Low Batt.

The function is used to set the voltage value at which the low battery warning is issued.

● Radio TX

This function sets the transmitter to send RF or not. If it is set as OFF, the transmitter does not send any data to the receiver.

Setting Values	Description
On	Power is on to the RF part, the data are transmitted.
Off	Power is off to the RF part, the data are not transmitted.

5.18 Advanced

5.18.1 Throttle Mode

The user needs to assign this function to a switch first. Set the neutral positions of accelerator and brake and adjust the ratio of accelerator and brake.

■ How to Set

Press the **SET** on NT-Brake. Set the neutral ratio of brake using the **LEFT** and the **RIGHT** and press the **SET**.

There are two kinds of Mode; 50:50 and 70:30, which show the ratio of the accelerator direction (FORWARD) to the brake direction (Reverse). FWD5/BRK5 means 50% for the accelerator direction and 50% for the brake direction. FWD7/BRK3 means 70% for the accelerator direction and 30% for the brake direction.

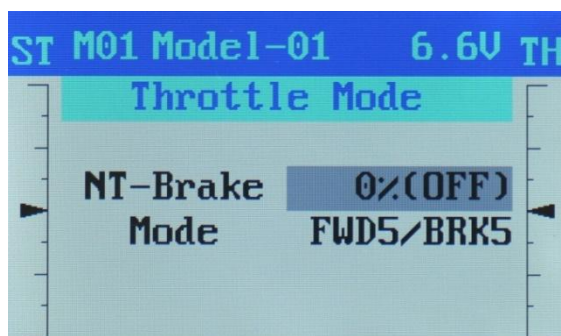

Setting Values	Description
On	Power is on to the RF part, the data are transmitted.
Off	Power is off to the RF part, the data are not transmitted.

5.18.2 ABS

While cornering with brake on, the vehicle may be push and lose traction. Such pushing can be prevented using ABS function.

ST M01 Model-01		6.6V TH	
ABS			
Mode	INH (Off)		
ABP	50	TGP	30
DLY	0	DTY	0
CYC	10	STM	0

■ How to Set

This function is initially inhibited (INH). Press the **SET** on Mode and then press the **RIGHT** to change the value to ACT. Press the **SET** again to activate the function.

Move to ABP using the **DOWN** to set the brake return amount value. The range of value is 0 to 100. The default value is 50. When the value is 0, the brake return does not work. (In other words, the ABS function does not work.) When the value is 50, the brake return works to the 50% position of trigger point. When the value is 100, the brake servo causes the brake return to the neutral position.

Move to DLY using the **DOWN** to delay for ABS. ABS starts operating after a specified time is passed if DLY is set. The range of DLY value is 0 to 100. The default value is 0. If the value is 0, there is no delay. If the value is 50, the delay is about 0.75 seconds. If the value is 100, the delay is about 1.5 seconds.

Move to CYC using the **DOWN** to set the brake pulse speed value. The smaller value is, the faster pulse is. The range of CYC value is 1 to 30. The default value is 10.

Move to TGP using the **RIGHT** and **UP** to set the trigger point. The range of TGP value is 10 to 100 and the default value is 10. The value is the percentage meaning that the end point of the trigger is 100%.

Move to DTY using the **DOWN** to set the brake pulse duty value. Duty is the ratio between the brake-on time and brake-off time. DTY value can one of -3, -2, -1, 0, 1, 2, 3. The smaller value is, the longer the brake-on time is.

Move to STM using the **DOWN** to set the steer mix value. STM can be ranged N10~N100, 0, E10~E100. If the value is 0, ABS operates without regard to steer position. If the value is N30, ABS operates if steer is positioned in neutral point or inside 30% of steer end point. If the value is E30, ABS operates if steer is positioned outside 30% of steer end point. The default value is 0.

5.18.3 TH-Acceleration

This function is used when the maximum throttle is required. If throttle trigger is moved slightly from its neutral point, the throttle will be set to the specified value so that the maximum power can be applied.

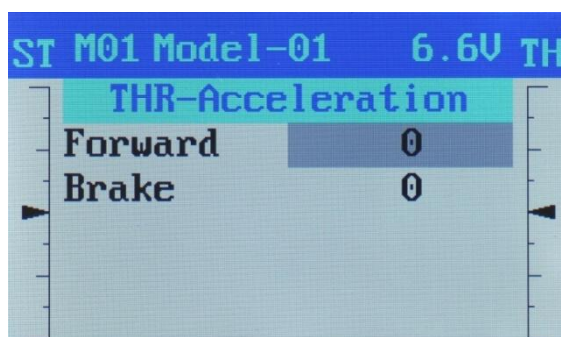

■ How to Set

Press **SET** to edit the value when the cursor is placed in Forward. Modify the value as desired using **LEFT** and **RIGHT**.

Press **DOWN** to move to Brake. when the cursor is placed in Forward. Modify the value as desired using **LEFT** and **RIGHT**.

Move to Brake using the **DOWN** to set the brake side acceleration value. Use **LEFT** and **RIGHT** to modify the value. If Brake is modified to the desired value, press **SET** again to save the value.

If the Brake is mixed to the 3rd channel and 4th channel, throttle acceleration can be applied to them separately and it works independently according to the set values.

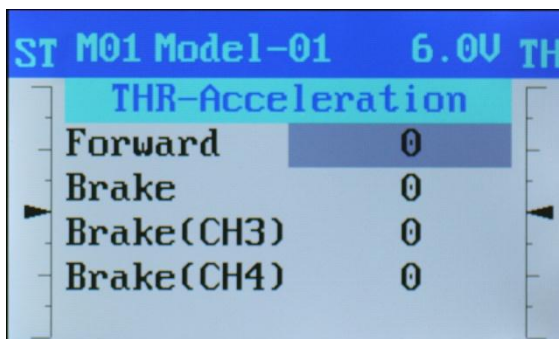

5.18.4 AT-Start

If the road is slippery and the throttle trigger is pulled abruptly, the car will spin with no traction. Using AT-Start function, the acceleration can be slowed down so that the car spins smoothly on the road.

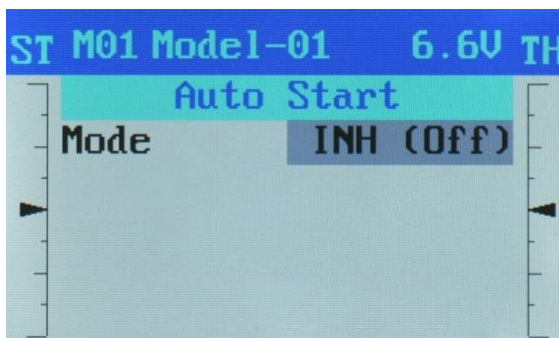

■ How to Set

Press the **SET** when placed in Mode, and use **RIGHT** to select AT&SW. Press the **SET** again to activate the function.

Move to Preset using the **DOWN**. Preset can be the values of 0, B1~B100, F1~F100. B means brake side and F means forward side. The default is 0.

Move to TGP using the **DOWN**. TGP can be the values ranging from 5 to 95. The default is 5.

Move to ATS using the **DOWN**. ATS is set to OFF in the beginning. Press **SET** and modify the value to Ready. Start function will operate if the throttle trigger is moved to the TGP point or above.

Caution

ATS will go back to Off state if start function is operated by throttle movement. In case that this function is required in next start, user needs to set ATS to Ready again.

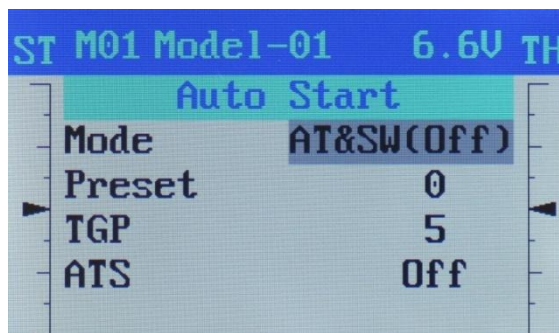

How to Set

Press **SET** when placed in Mode, and use **RIGHT** to select AT. Press **SET** again to activate the function.

Move to Preset using the **DOWN**. Preset can be the values of 0, B1~B100, F1~F100. B means brake side and F means forward side. The default is 0.

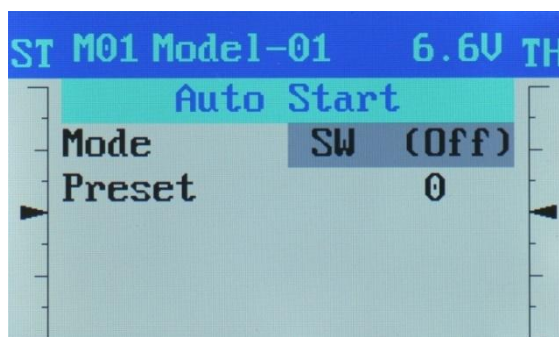

5.18.5 Idle-Up

This function is used if GP car is used and idling RPM of the engine needs to be controlled. It can be useful in starting the engines with moderately high RPM. The push switch can be applied for idle-up.

It moves the neutral point to either acceleration or brake side so as to manage the idling RPM of the engine.

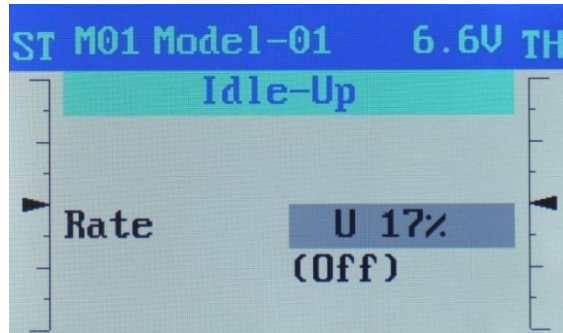

■ How to Set

Press **SET**, and use the **LEFT** and/or the **RIGHT** to modify the values. Press **SET** again to save the value. The value can be modified to 100 toward the up side and to 100 toward the down side. The default is 0, which means the neutral point.

5.18.6 ATL

It limits the end point of brake side for throttle movement. This value can be assigned to the dial switches. (see How to set Dial Switch).

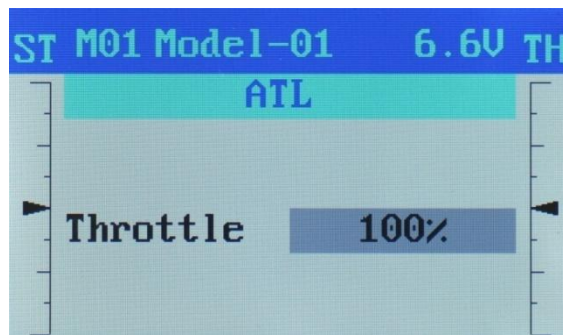

■ How to Set

Press the **SET**, and use the **LEFT** and/or the **RIGHT** to modify the values. Press the **SET** again to save the value. The value can be modified from 0% to 100%. The default is 100%.

5.18.7 AUX CH Position

It is used to change the position of auxiliary channels. (the 3rd channel and the 4th channel.) Auxiliary channels can be assigned to the Dial Switches or Trim switches for instant change.

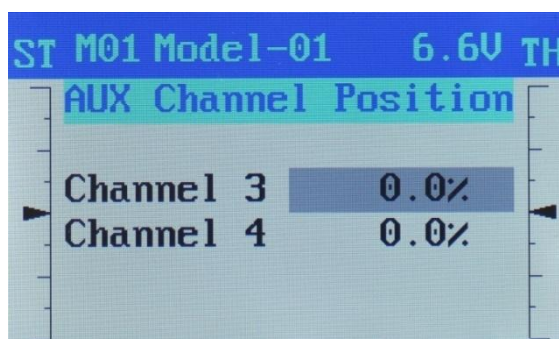

■ How to Set

Move to the channel which is desired to change the position. Press the **SET** and change the position value. The value is the percentage ranging from -100% to 100%, and it can be controlled with resolution of 0.1%. Press the **LEFT** to decrease the value by 0.1%. Press the **RIGHT** to increase the value by 0.1%. Press the **DOWN** to decrease the value by 1%. Press the **UP** to increase the value by 1%. The default is 0%.

5.18.8 Boat Mode

Boat does not include move backward, thus the whole range of -100%~+100% can be used as forward movement. If TRG-BRK is set to Cut Off, all range of the receiver output will be used for acceleration.

Tilt Mixing is used to mix the 1st channel (typically, rudder channel) and 3rd channel.

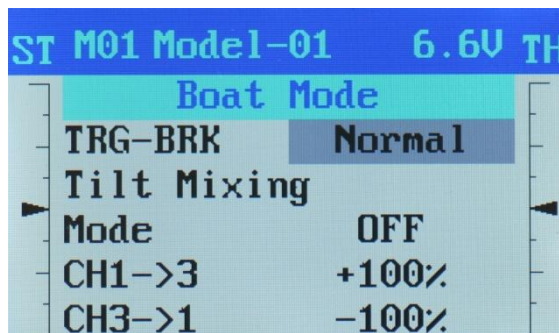

■ How to Set

Press the **SET** when placed in TRG-BRK, and use the **RIGHT** to modify it to Cut Off. Press the **SET** again to save it.

Move to Mode using the **DOWN**. Press the **SET** and use the **RIGHT** to change it to On. Press the **SET** again to activate the function.

Move to CH1->3 using the **DOWN**. Use the **LEFT** and the **RIGHT** to modify the rate. Press the **SET** again to save the modified value. The value is in the range from -100% to 100%. The default is 100%.

Move to Ch 3 → 1 using the **DOWN**. Use the **LEFT** and the **RIGHT** to modify the rate. Press the **SET** again to save the modified value. The value is in the range from -100% to 100%. The default is 100%.

5.18.9 Prog Mix

It is used to mix one channel to the other channel. Two mixing is available and each can be programmable independently and work independently.

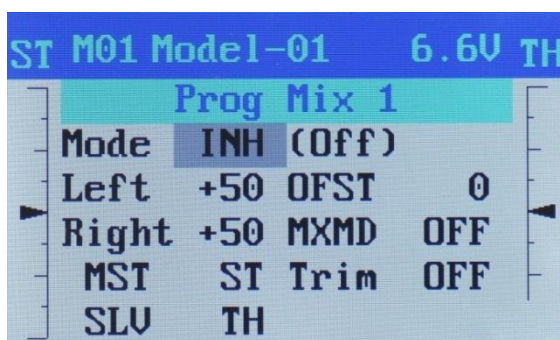

■ How to Set

Press the **SET** when being placed in the Mode, and use the **RIGHT** to select ACT. Press the **SET** again to save the activation.

Move to MST by pressing the **DOWN** twice. Press the **SET** and select the master channel using the **LEFT** and the **RIGHT**. Press the **SET** again to save the master channel.

Move to MST using the **DOWN** twice. Press the **SET** and select the slave channel using the **LEFT** and the **RIGHT**. Press the **SET** again to save the slave channel.

Move to the Left (Or FWRD) by pressing the **UP** three times. Press the **SET** and use the **LEFT** and the **RIGHT** to modify the mix rate. Press the **SET** again to save the rate. Mix rate is the range between -10 and 120. The default is 50.

Move to the Right (Or BRAK) by pressing the **DOWN** three times. Press the **SET** and use the **LEFT** and the **RIGHT** to modify the mix rate. Press the **SET** again to save the rate. Mix rate is the range between -10 and 120. The default is 50.

Move to OFST by pressing the **UP** and the **RIGHT**. Press the **SET** and use the **LEFT** and the **RIGHT** to modify the offset. Press the **SET** again to save the offset. Offset is the range between -100 and 100. The default is 0.

Move to MXMD using the **DOWN**. Press the **SET** and use the **LEFT** and the **RIGHT** to select OFF and MIX. Press the **SET** again to save the selection. If MIX is selected, mixing is applied after master channel's function is applied. If OFF is selected, mixing is applied before master channel's function is applied.

Move to MXMD using the **DOWN**. Press the **SET** and use the **LEFT** and the **RIGHT** to select OFF and ON. Press the **SET** again to save the selection. If ON is selected, mixing is applied after master channel's trim is applied. If OFF is selected, mixing is applied before master channel's trim is applied.

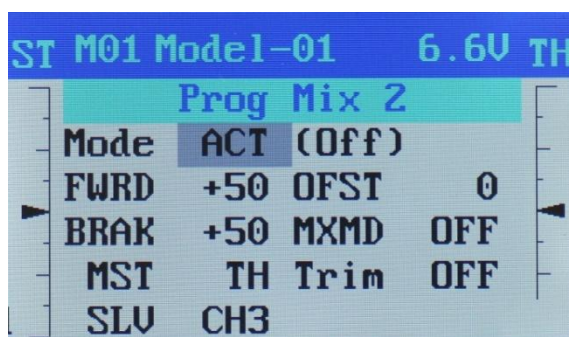

ST M01 Model-01 6.6V TH			
Prog Mix 2			
Mode	ACT	(Off)	
FWRD	+50	OFST	0
BRAK	+50	MXMD	OFF
MST	TH	Trim	OFF
SLV	CH3		

■ System Specifications

Transmitter		Receiver	
Model	TS401	Model	RP24RS5D
Frequency	2.4GHz Band DSSS	Frequency	2.4GHz Band DSSS
Operating Voltage	6V	Operating Voltage	4.6V ~ 12.6V
Power Supply	5AA Alkaline Dry Cell DC 7.2V	Weight	7.5g
Weight	646g		

■ Troubleshooting Guide

Troubles		Causes	Troubleshooting
Unable to transmit the radio.		No battery or not enough voltage.	Charge the battery.
Alarm does not stop.	Alarm sounds continuously.	Low voltage of battery.	Charge the battery.
	Alarm sounds at regular intervals.	The interval timer is "ON".	Turn "OFF" the interval.
No sound when pressing keys.		The buzzer option is set as "OFF".	Turn the Buzzer setting "ON" in the system menu.
Servos move slowly.		The value set in the speed menu is too low/small.	Change the speed setting value to the default or higher value.
		Low battery.	Check the battery.
		Linkage is too tight.	Free the linkage from binding.
Although the settings for the left and the right are same, the steering angles are different.		Trim or Subtrim is not in the neutral position.	Edit the trim and subtrim.
Servo does not move to the end of the range.		D-rate and EPA setting values are too high.	Reset the linkage on the servo.
Servo is not able to be controlled by the trim switch.		Trim is out of operation range.	Set trim as zero "0", and put the servo horn and linkage in the neutral position.
Lap-timer and Interval timer do not work.		Timer is set as "OFF".	Set the timer as "ON".
LED is blinking white or red.		White=Transmitter and receiver are not bound properly.	Repeat the bind process again.
		Red=Connection Lost.	
Transmitter and receiver do not bind.		Binding button of the receiver has been pressed for too long.	Press the button key on the binding menu immediately after pressing the binding button.

■ Abbreviation

Abbreviation	Meaning
NT-BRAKE	Neutral Brake
ABS	Anti-Lock Brake System
PROG MIX	Programmable Mix
D/R	Dual Rate
EXPS	Steer Exponential
EXPF	Throttle Exponential (Forward side)
EXPB	Throttle Exponential (Brake side)
EXP3	Brake Exponential for Channel 3
EXP4	Brake Exponential for Channel 4
SPTn	Steer Speed (Turn side)
SPRn	Steer Speed (Return side)
AB.P	ABS function (Return amount)
ABSD	ABS function (Delay)
CYCL	ABS function (cycle speed)
ACCF	Throttle acceleration (Forward side)
ACCB	Throttle acceleration (Brake side)
THS1	Throttle speed (All/Low)
THS2	Throttle speed (MID)
THS3	Throttle speed (High)
TRMS	Steer Trim
TRMT	Throttle Trim
3CH	Channel 3
4CH	Channel 4
SBT1	Sub trim (CH1)
SBT2	Sub trim (CH2)
SBT3	Sub trim (CH3)
SBT4	Sub trim (CH4)
IDLE	Idle-up
TL13	Tilt Mixing (1→3)
TL31	Tilt Mixing (3→1)
PM1A	Program Mix 1 (LEFT/FWRD/UP sides)
PM1B	Program Mix 1 (RIGHT/BRAKE/DOWN sides)
PM2A	Program Mix 2 (LEFT/FWRD/UP sides)
PM2B	Program Mix 2 (RIGHT/BRAKE/DOWN sides)
B3RT	Channel 3 brake mixing rate
B3DL	Channel 3 brake mixing delay
B3AP	Channel 3 brake mixing ABS return amount
B3AD	Channel 3 brake mixing ABS delay
B4RT	Channel 4 brake mixing rate
B4DL	Channel 4 brake mixing delay
B4AP	Channel 4 brake mixing ABS return amount
B4AD	Channel 4 brake mixing ABS delay
B34RT	brake mixing rate for both channel 3 and channel 4



■ Warranty

1 YEAR LIMITED WARRANTY

Warranty Period

Radiopost Inc. (Radiopost RC) warrants that the Products purchased (the "Product") will be free from defects in materials and workmanship for a period of 1 year from the date of purchase by the Purchaser.

Limited Warranty

(a) This warranty is limited to the original Purchaser ("Purchaser") and is not transferable. REPAIR OR REPLACEMENT AS PROVIDED UNDER THIS WARRANTY IS THE EXCLUSIVE REMEDY OF THE PURCHASER. This warranty covers only those Products purchased from an authorized Radiopost dealer located in the US & Canada. Third party transactions are not covered by this warranty. Proof of purchase is required for warranty claims. Further, Radiopost reserves the right to change or modify this warranty without notice and disclaims all other warranties, express or implied.

(b) Limitations- RADIOPOST MAKES NO WARRANTY OR REPRESENTATION, EXPRESS OR IMPLIED, ABOUT NON-INFRINGEMENT, MERCHANTABILITY OR FITNESS FOR A PARTICULAR PURPOSE OF THE PRODUCT. THE PURCHASER ACKNOWLEDGES THAT THEY ALONE HAVE DETERMINED THAT THE PRODUCT WILL SUITABLY MEET THE REQUIREMENTS OF THE PURCHASERS INTENDED USE.

(c) Purchaser Remedy- Radiopost's sole obligation hereunder shall be that Radiopost will, at its option, (i) repair or (ii) replace, any Product determined by Radiopost to be defective. In the event of a defect, these are the Purchaser's exclusive remedies. Radiopost reserves the right to inspect any and all equipment involved in a warranty claim. Repair or replacement decisions are at the sole discretion of Radiopost. This warranty does not cover cosmetic damage or damage due to acts of God, accident, misuse, abuse, negligence, commercial use, or modification of or to any part of the Product. This warranty does not cover damage due to Improper installation, operation, maintenance, or attempted repair by anyone other than Radiopost. Return of any goods by Purchaser must be approved in writing by Radiopost before shipment.

Damage Limits:

RADIOPOST SHALL NOT BE LIABLE FOR SPECIAL, INDIRECT OR CONSEQUENTIAL DAMAGES, LOSS OF PROFITS OR PRODUCTION OR COMMERCIAL LOSS IN ANY WAY CONNECTED WITH THE PRODUCT, WHETHER SUCH CLAIM IS BASED IN CONTRACT, WARRANTY, NEGLIGENCE, OR STRICT LIABILITY. Further, in no event shall the liability of Radiopost exceed the individual price of the Product on which liability is asserted. As Radiopost has no control over use, setup, final assembly, modification or misuse, no liability shall be assumed nor accepted for any resulting damage or injury. By the act of use, setup or assembly, the user accepts all resulting liability. If you as the Purchaser or user are not prepared to accept the liability associated with the use of this Product, you are advised to return this Product immediately in new and unused condition to the place of purchase, please contact your dealer for specific return policies.



RETURN POLICY (RMA)

Safety Precautions:

This is a sophisticated hobby Product and must be operated with caution, as some prerequisite knowledge of mechanical abilities may be required. It must be operated with caution and common sense and requires some basic mechanical ability. Failure to operate this Product in a safe and responsible manner could result in injury or damage to the Product or other property. This Product is not intended for use by children without direct adult supervision. The Product manual contains instructions for safety, operation and maintenance. It is essential to read and follow all the instructions and warnings in the manual, prior to assembly, setup or use, in order to operate correctly and avoid damage or injury.

Questions, Assistance, and Repairs:

Contact your local dealer for assistance or you may reach our customer/product support at 1.888.947.5551 or service@radiopost.com.

Inspection or Repairs

If this Product needs to be inspected or repaired, please call for a Return Merchandise Authorization (RMA). Pack the Product securely using a shipping carton. Please note that original boxes may be included, but are not designed to withstand the rigors of shipping without additional protection. Ship via a carrier that provides tracking and insurance for lost or damaged parcels, as **Radiopost is not responsible for merchandise until it arrives and is accepted at our facility.**

If you do not have internet access, please include a letter with your complete name, street address, email address and phone number where you can be reached during business days, your RMA number, a list of the included items, method of payment for any non-warranty expenses and brief summary of the problem. Your original sales receipt must also be included for warranty consideration. Be sure your name, address and RMA number are clearly written on the outside of the shipping carton.

Warranty Inspection and Repairs

To receive warranty service, you must include your original sales receipt verifying the proof-of-purchase date. Provided warranty conditions have been met, your product will be repaired or replaced free of charge.

Repair or replacement decisions are at the sole discretion of Radiopost Inc.

Federal Communication Commission Interference Statement

This equipment has been tested and found to comply with the limits for a Class B digital device, pursuant to Part 15 of the FCC Rules. These limits are designed to provide reasonable protection against harmful interference in a residential installation. This equipment generates, uses and can radiate radio frequency energy and, if not installed and used in accordance with the instructions, may cause harmful interference to radio communications. However, there is no guarantee that interference will not occur in a particular installation. If this equipment does cause harmful interference to radio or television reception, which can be determined by turning the equipment off and on, the user is encouraged to try to correct the interference by one of the following measures:

- Reorient or relocate the receiving antenna.
- Increase the separation between the equipment and receiver.
- Connect the equipment into an outlet on a circuit different from that to which the receiver is connected.
- Consult the dealer or an experienced radio/TV technician for help.

IMPORTANT NOTE:

FCC RF Radiation Exposure Statement:

This equipment complies with FCC RF radiation exposure limits set forth for an uncontrolled environment. This equipment should be installed and operated with a minimum distance of 20 centimeters between the radiator and your body. This transmitter must not be co-located or operating in conjunction with any other antenna or transmitter.

NOTE: THE MANUFACTURER IS NOT RESPONSIBLE FOR ANY RADIO OR TV INTERFERENCE CAUSED BY UNAUTHORIZED MODIFICATIONS TO THIS EQUIPMENT. SUCH MODIFICATIONS COULD VOID THE USER'S AUTHORITY TO OPERATE THE EQUIPMENT.



■ Contact

Radiopost, Inc.

26445 Rancho Parkway South. Suite B
Lake Forest, CA 92630 USA

T. 949.273.8282 / 888.947.5551

F. 949.273.8285 / 888.947.5557

www.radiopost.com

