

Table of Contents

<u>FCC Warning</u>	3
<u>Mechanical Assembly</u>	4
<u>Front Box</u>	4
<u>Gland</u>	5
<u>PCB Assembly</u>	6
<u>PCB Cover</u>	7
<u>Label</u>	8
<u>Antenna</u>	9
<u>Mounting</u>	10
<u>AC Cable</u>	11
<u>Top Cover</u>	12
<u>Final Assembly</u>	13
<u>Field Installation</u>	14
<u>General Instructions</u>	14
<u>Installation Steps</u>	14

	DRAW NO.: DC00019-001		
	DESCRIPTION: FINAL ASSEMBLY REPEATER RX-TX	REV A	SH. <u> 2 </u> OF <u> 19 </u>

FCC Warning

FCC Warning

Modifications not expressly approved by the manufacturer could void the user authority to operate the equipment under FCC Rules.

	DRAW NO.: DC00019-001		
	DESCRIPTION: FINAL ASSEMBLY REPEATER RX-TX	REV A	SH. _3_ OF _19_

Mechanical Assembly

Front Box

Attach **standoffs** with **plain washer**, **nut** and **spring washer** to the lower **board**.

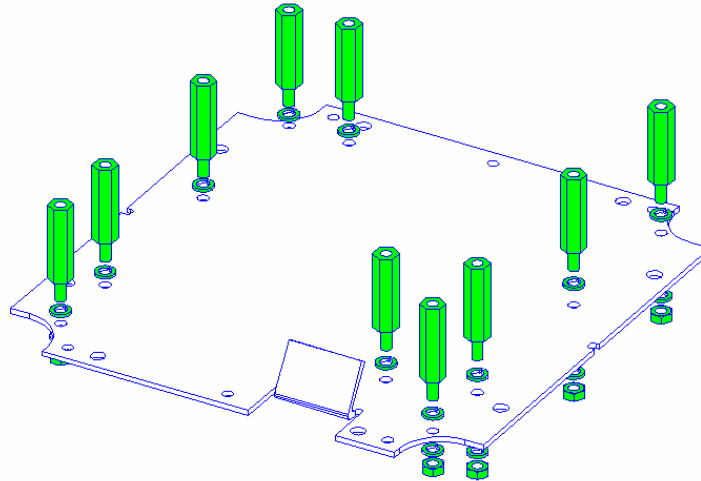

Attach the lower **board** into the **front box** and assemble **screws**.

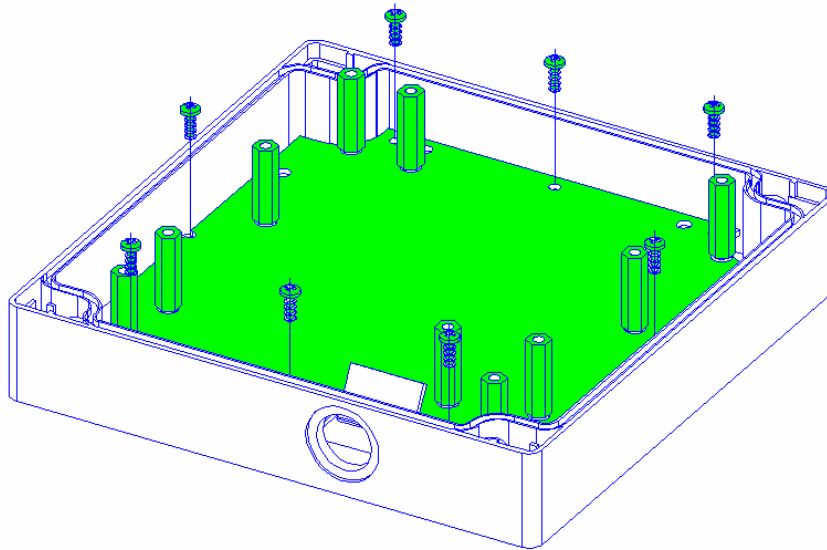

	DRAW NO.: DC00019-001		
	DESCRIPTION: FINAL ASSEMBLY REPEATER RX-TX	REV A	SH. _4_ OF _19_

Gland

Assemble **gland** with **nut** and **washer**.

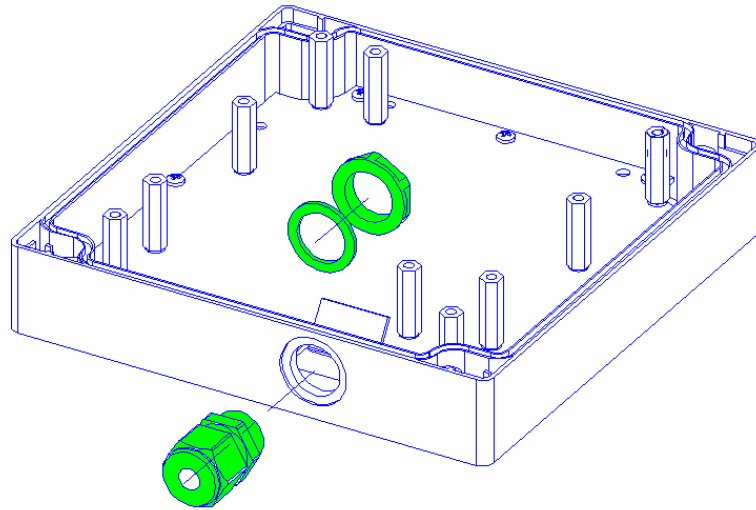

	DRAW NO.: DC00019-001		
	DESCRIPTION: FINAL ASSEMBLY REPEATER RX-TX	REV A	SH. <u>_5_</u> OF <u>_19_</u>

PCB Assembly

Assemble the **PCB** into the **front box** and hold it with **standoffs, screws,** and **washers**.

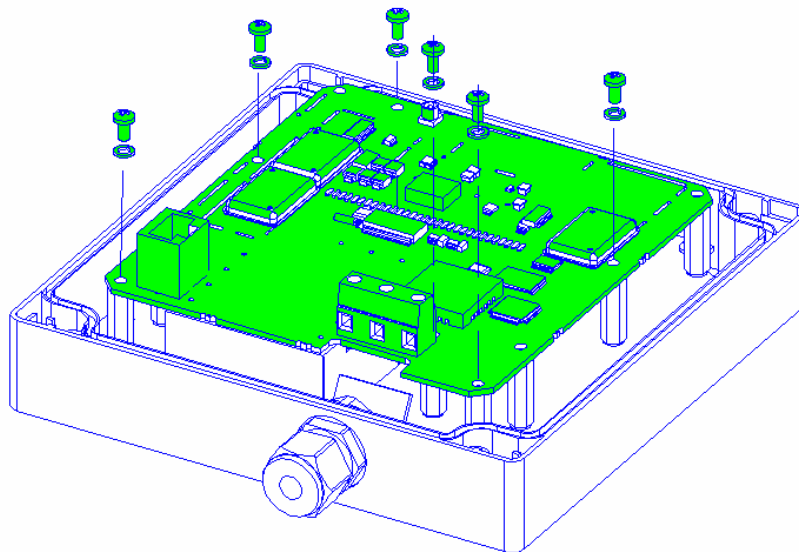
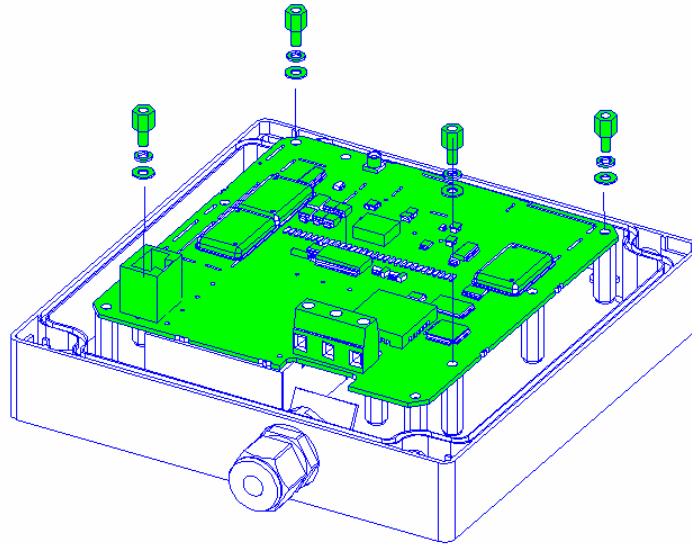

	DRAW NO.: DC00019-001		
	DESCRIPTION: FINAL ASSEMBLY REPEATER RX-TX	REV A	SH. <u>_6_</u> OF <u>_19_</u>

PCB Cover

Place the **RF shield** above **PCB** and assemble **screws** and **washers**.

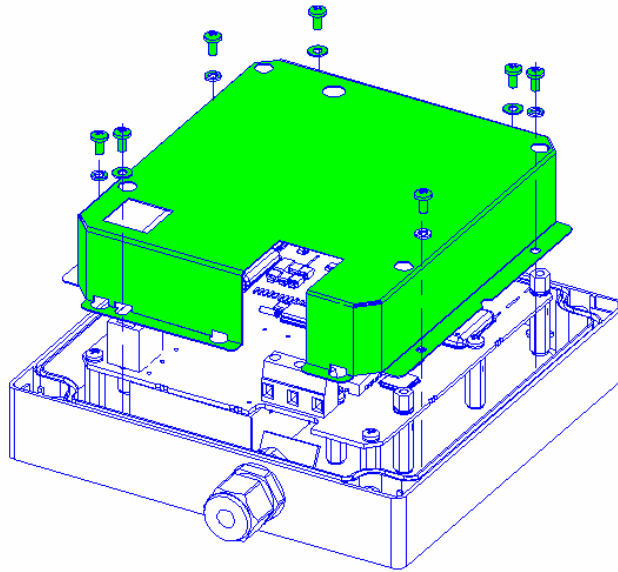

	DRAW NO.: DC00019-001		
	DESCRIPTION: FINAL ASSEMBLY REPEATER RX-TX	REV A	SH. _7_ OF _19_

Label

Place **warning label** on top of the **RF shield**.

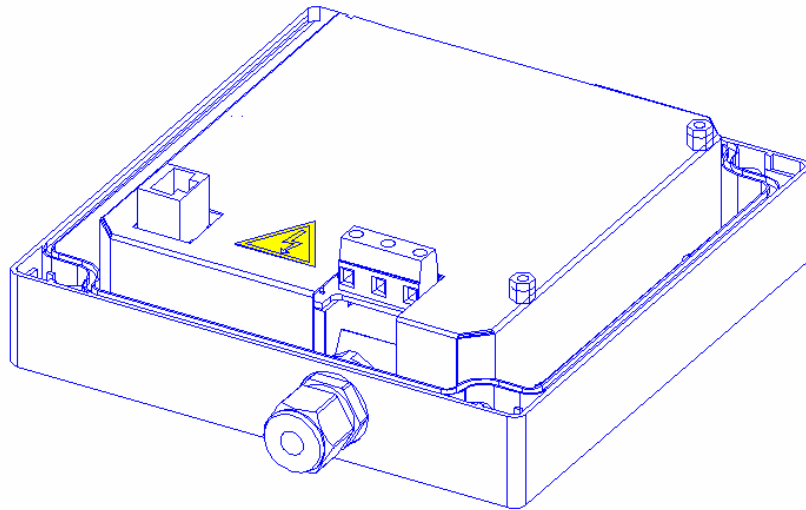

	DRAW NO.: DC00019-001		
	DESCRIPTION: FINAL ASSEMBLY REPEATER RX-TX	REV A	SH. <u>_8_</u> OF <u>_19_</u>

Antenna

Place the **antenna** and assemble **plastic screws**.

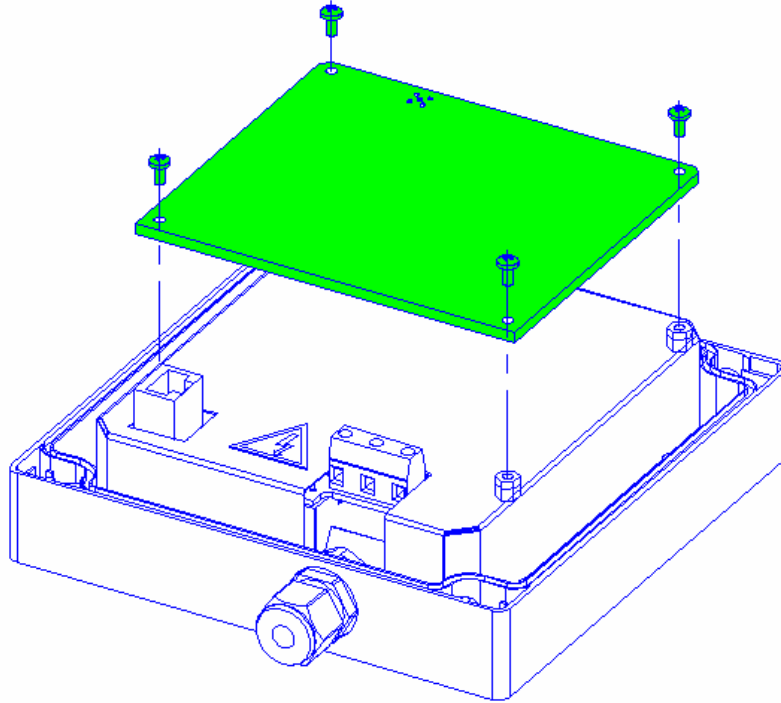

	DRAW NO.: DC00019-001		
	DESCRIPTION: FINAL ASSEMBLY REPEATER RX-TX	REV A	SH. <u>_9_</u> OF <u>_19_</u>

Mounting

Place the **bracket** and tighten with **screws**.

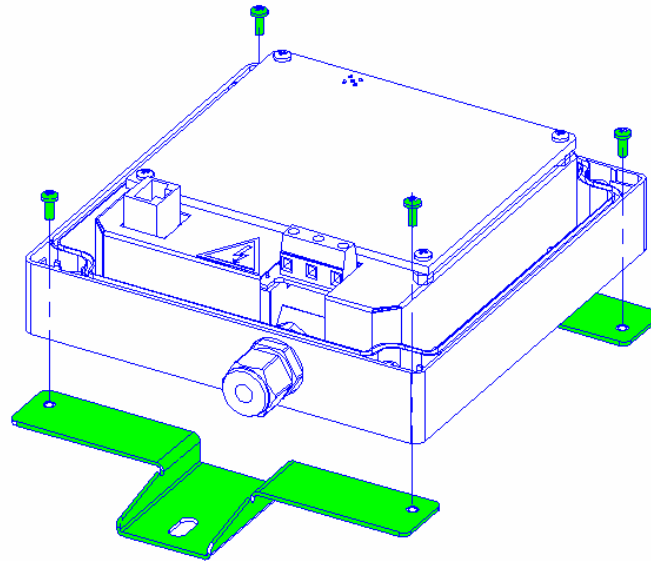

	DRAW NO.: DC00019-001		
	DESCRIPTION: FINAL ASSEMBLY REPEATER RX-TX	REV A	SH. _10_ OF _19_

AC Cable

place the **AC cable** into the **front box**

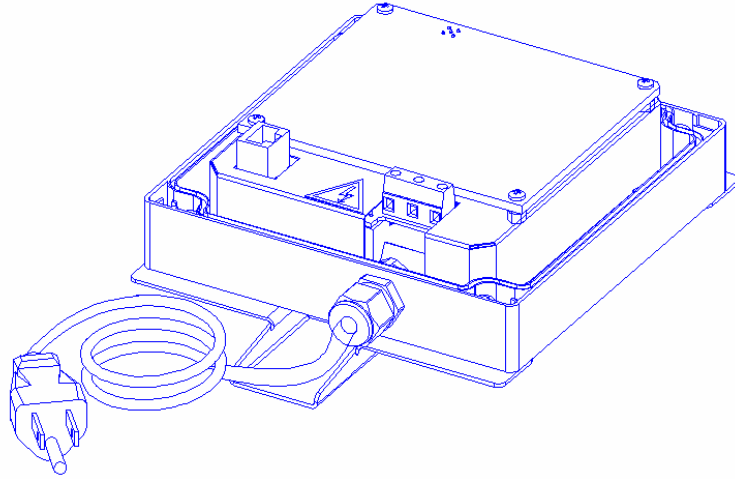

Assemble **AC cable** with screws

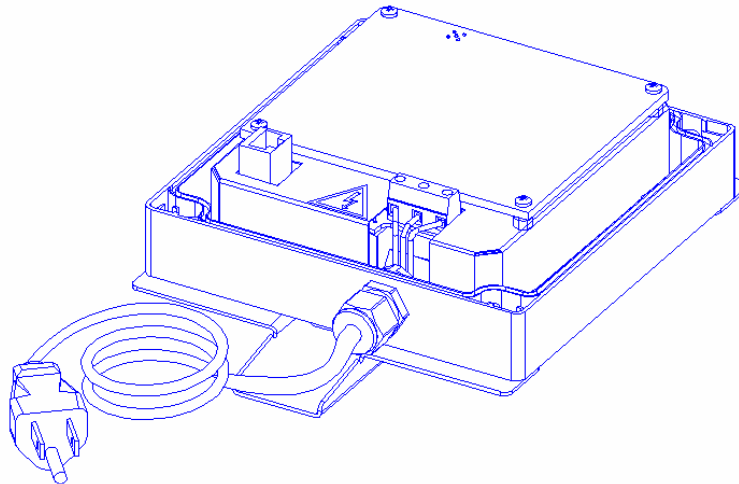

	DRAW NO.: DC00019-001		
	DESCRIPTION: FINAL ASSEMBLY REPEATER RX-TX	REV A	SH. _11_ OF _19_

Top Cover

Place the **top cover** on the **front box** and assemble **screws**.

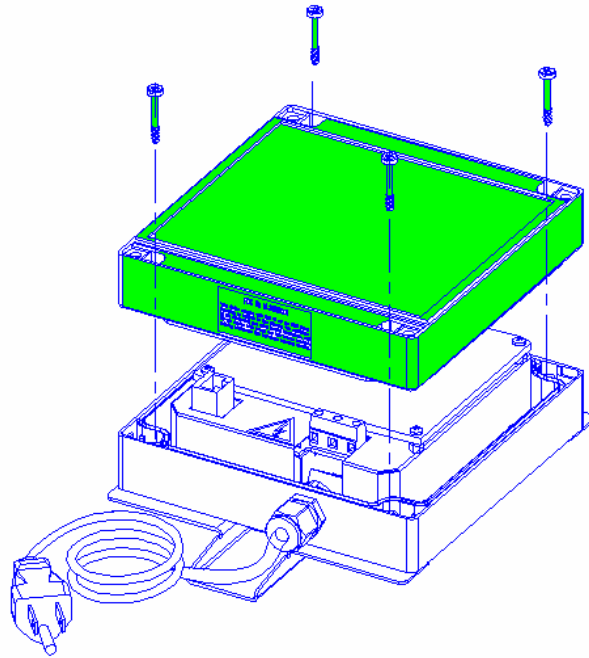

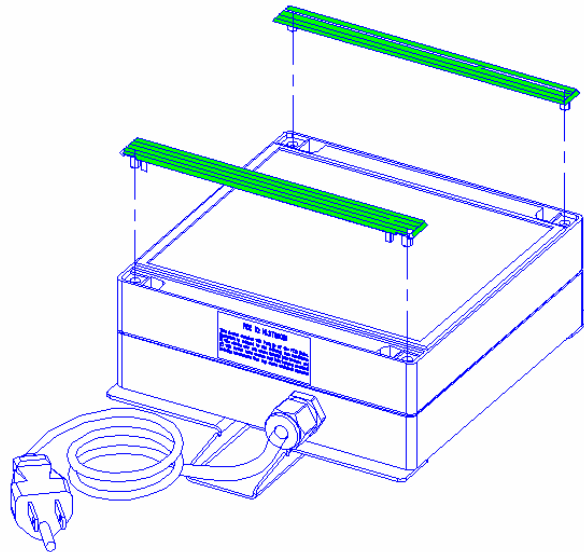

Sealed the **top cover** with **strips**.

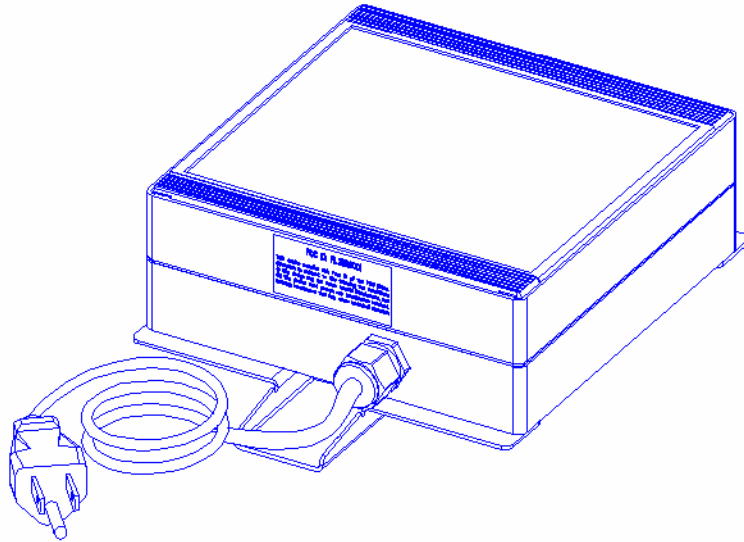

	DRAW NO.: DC00019-001		
	DESCRIPTION: FINAL ASSEMBLY REPEATER RX-TX	REV A	SH. _12_ OF _19_

Final Assembly



	DRAW NO.: DC00019-001		
	DESCRIPTION: FINAL ASSEMBLY REPEATER RX-TX	REV A	SH. _13_ OF _19_

Field Installation

General Instructions

The NTR must be installed at least 3 meters above the floor. Select the installation location in where no moving/mobile nor static objects would exist or enter into within 2 meters of the NTR surrounding, excluding the wall or pipe where the NTR is installed on.

Installation Steps

Locate installation place, on a roof of a dominate building in the area where the NTR services are required.



	DRAW NO.: DC00019-001		
	DESCRIPTION: FINAL ASSEMBLY REPEATER RX-TX	REV A	SH. _14_ OF _19_

Mark 2 point for drilling.



	DRAW NO.: DC00019-001		
	DESCRIPTION: FINAL ASSEMBLY REPEATER RX-TX	REV A	SH. _15_ OF _19_

drill 2 holes.



	DRAW NO.: DC00019-001		
	DESCRIPTION: FINAL ASSEMBLY REPEATER RX-TX	REV A	SH. _16_ OF _19_

assemble screw-holders.



	DRAW NO.: DC00019-001		
	DESCRIPTION: FINAL ASSEMBLY REPEATER RX-TX	REV A	SH. _17_ OF _19_

Assemble 2 screws.



	DRAW NO.: DC00019-001		
	DESCRIPTION: FINAL ASSEMBLY REPEATER RX-TX	REV A	SH. _18_ OF _19_

NTR Final installation



	DRAW NO.: DC00019-001		
	DESCRIPTION: FINAL ASSEMBLY REPEATER RX-TX	REV A	SH. _19_ OF _19_