



## Table of Contents

<b><u>FCC Warning</u></b> .....	3
<b><u>Mechanical Assembly</u></b> .....	4
Front Box .....	4
Gland .....	5
PCB Assembly.....	6
PCB Cover.....	7
Label .....	8
Antenna .....	9
Mounting .....	10
AC Cable .....	11
Top Cover .....	12
Final Assembly .....	13
<b><u>Field Installation</u></b> .....	14
General Instructions.....	14
Installation Steps .....	14

	<b>DRAW NO.:</b> DC00019-001		
	<b>DESCRIPTION:</b>  FINAL ASSEMBLY REPEATER RX-TX	<b>REV</b>  A	SH. <u>  2  </u> OF <u>  19  </u>

## FCC Warning

### FCC Warning

Modifications not expressly approved by the manufacturer could void the user authority to operate the equipment under FCC Rules.

In order to comply with FCC RF Exposure requirements, the NTR unit must be installed in such a way that there is a 2 meters separation distance between it and all persons during normal operation.

The installer must maintain 2 meters separation distance from the NTR when the device is operational.

	<b>DRAW NO.:</b> DC00019-001		
	<b>DESCRIPTION:</b>  FINAL ASSEMBLY REPEATER RX-TX	<b>REV</b>  A	SH. <u>  3  </u> OF <u> 19 </u>

## Mechanical Assembly

### Front Box

Attach **standoffs** with **plain washer**, **nut** and **spring washer** to the lower **board**.

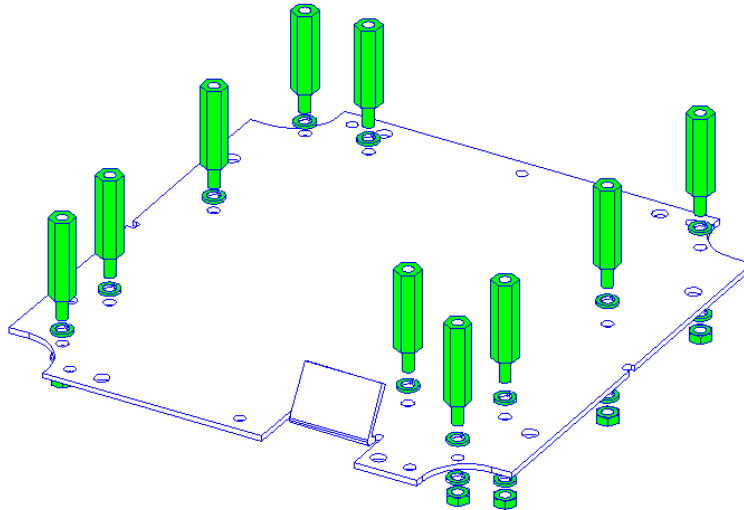

Attach the lower **board** into the **front box** and assemble **screws**.

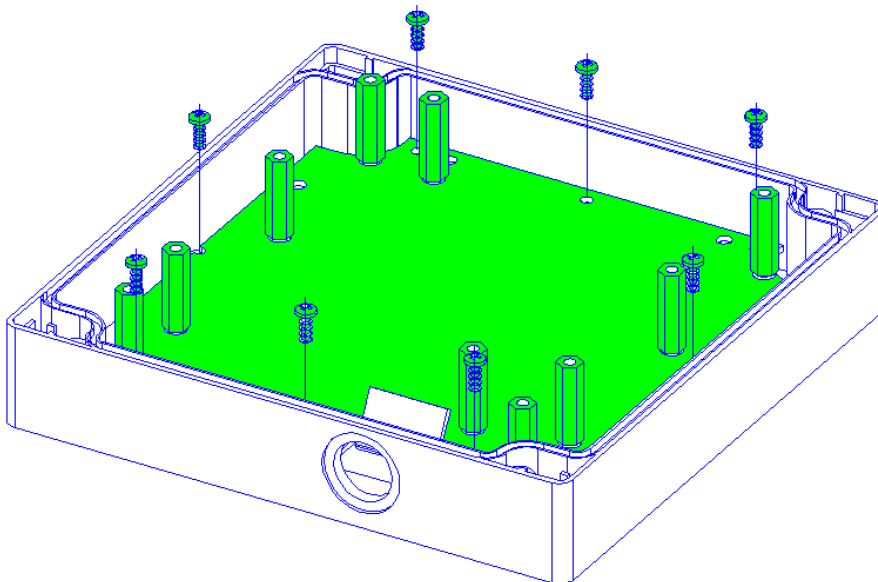

	<b>DRAW NO.:</b> DC00019-001		
	<b>DESCRIPTION:</b>  FINAL ASSEMBLY REPEATER RX-TX	<b>REV</b>  A	SH. <u>_4_</u> OF <u>_19_</u>

# Gland

Assemble **gland** with **nut** and **washer**.

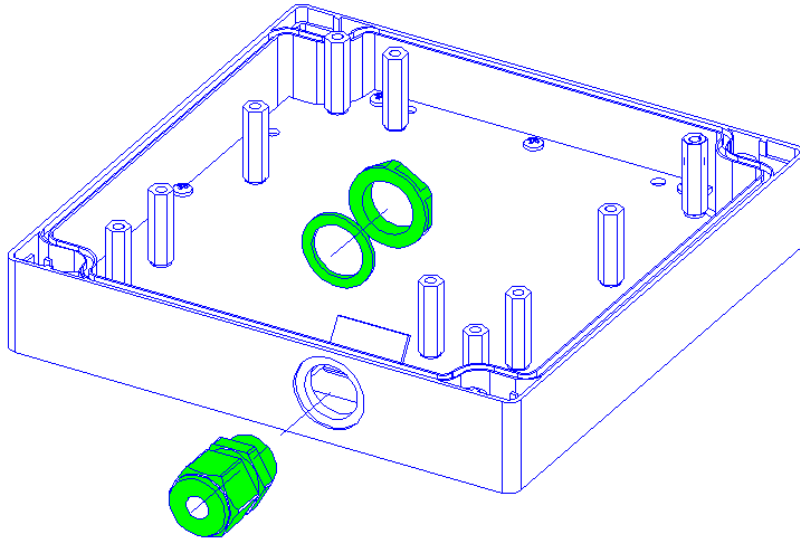

	<b>DRAW NO.:</b> DC00019-001		
	<b>DESCRIPTION:</b> FINAL ASSEMBLY REPEATER RX-TX	<b>REV</b> A	SH. <u>5</u> OF <u>19</u>

## PCB Assembly

Assemble the **PCB** into the **front box** and hold it with **standoffs**, **screws**, and **washers**.

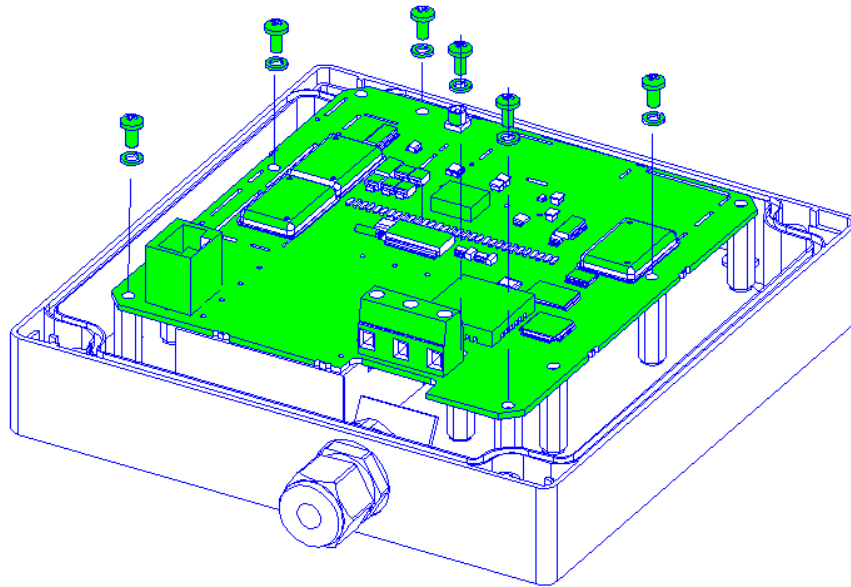
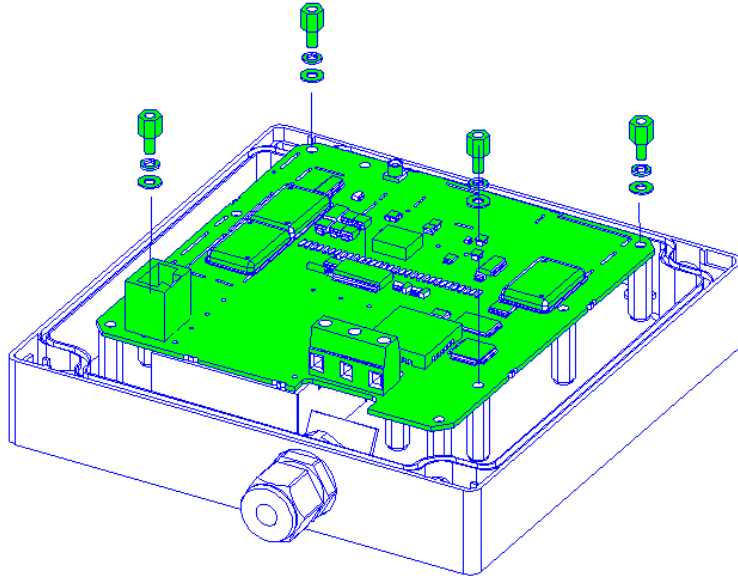

	<b>DRAW NO.:</b> DC00019-001		
	<b>DESCRIPTION:</b>  FINAL ASSEMBLY REPEATER RX-TX	<b>REV</b>  A	SH. _6_ OF _19_

## PCB Cover

Place the **RF shield** above **PCB** and assemble **screws** and **washers**.

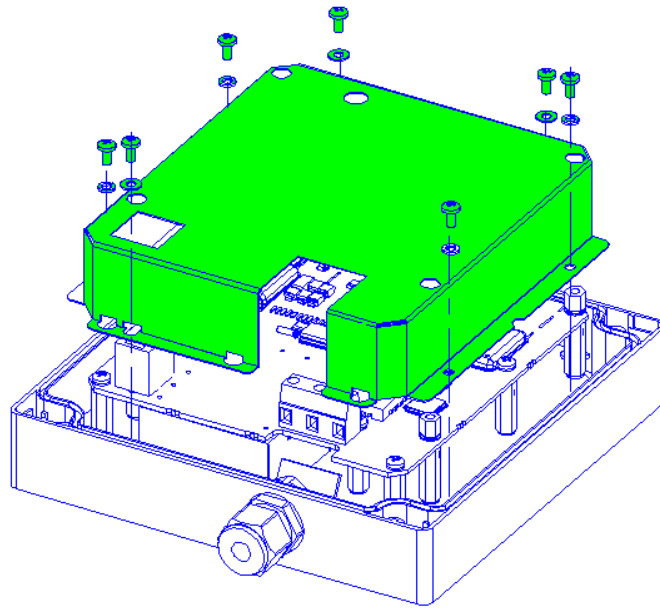

	<b>DRAW NO.:</b> DC00019-001		
	<b>DESCRIPTION:</b>  FINAL ASSEMBLY REPEATER RX-TX	<b>REV</b>  A	SH. _7_ OF _19_

# Label

Place **warning label** on top of the **RF shield**.

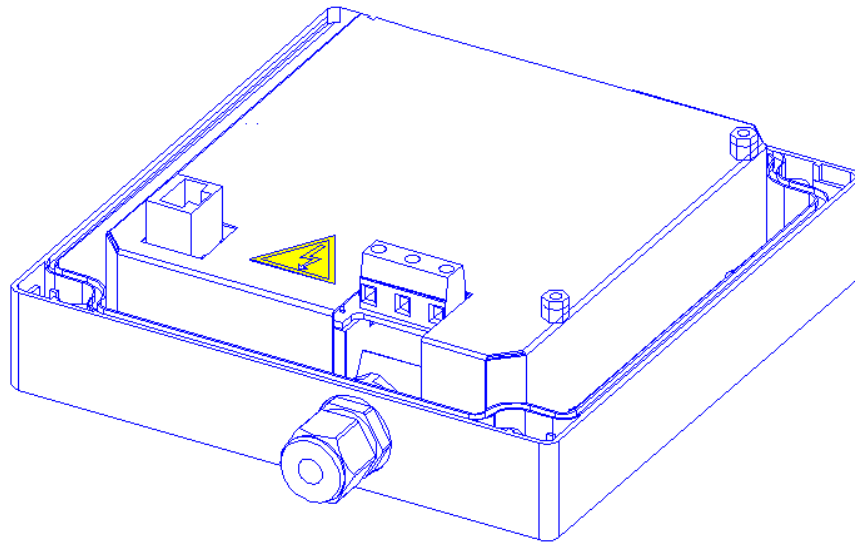



	<b>DRAW NO.:</b> DC00019-001		
	<b>DESCRIPTION:</b> FINAL ASSEMBLY REPEATER RX-TX	<b>REV</b> A	SH. <u>8</u> OF <u>19</u>

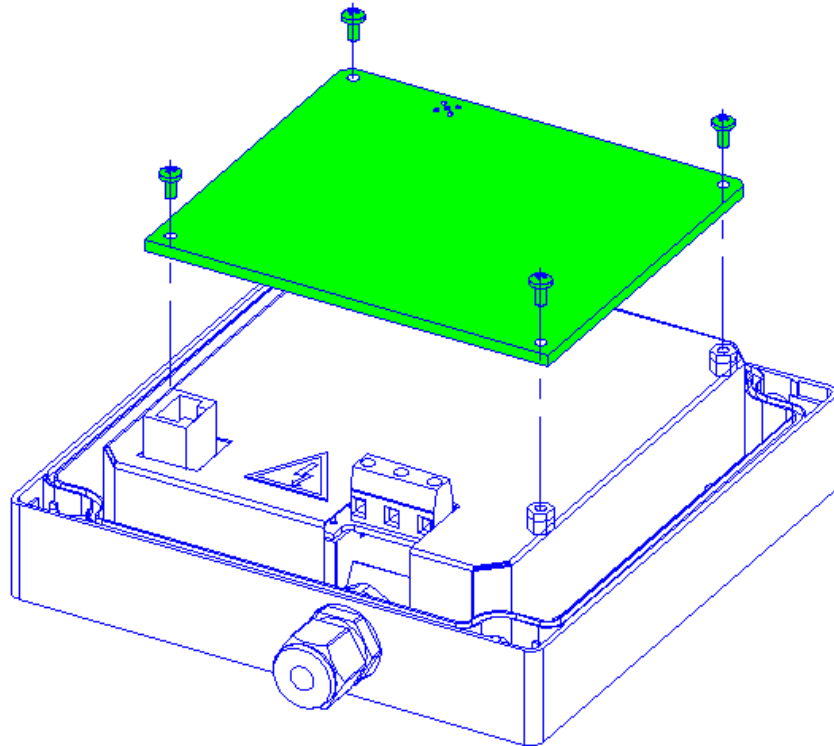

## Antenna

Place the **antenna** and assemble **plastic screws**.



	<b>DRAW NO.:</b> DC00019-001		
	<b>DESCRIPTION:</b> FINAL ASSEMBLY REPEATER RX-TX	<b>REV</b> A	SH. <u>_9_</u> OF <u>_19_</u>

## Mounting

Place the **bracket** and tighten with **screws**.

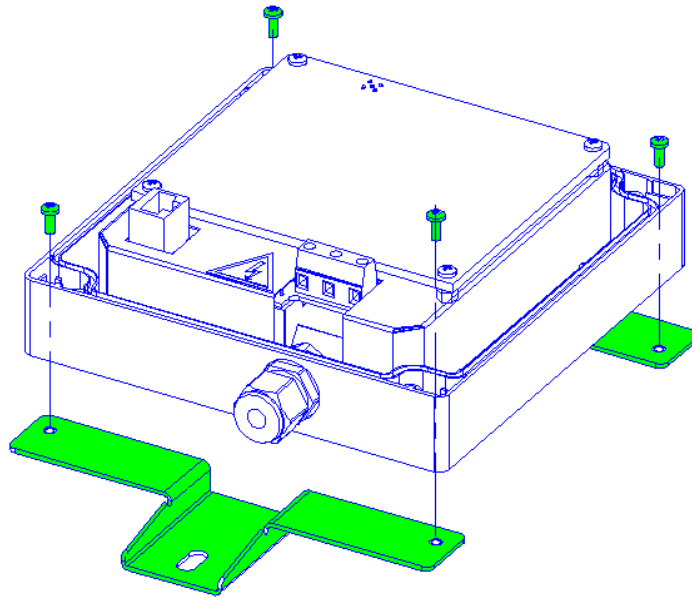

	<b>DRAW NO.:</b> DC00019-001		
	<b>DESCRIPTION:</b>  FINAL ASSEMBLY REPEATER RX-TX	<b>REV</b>  A	SH. _10_ OF _19_

# AC Cable

place the **AC cable** into the **front box**

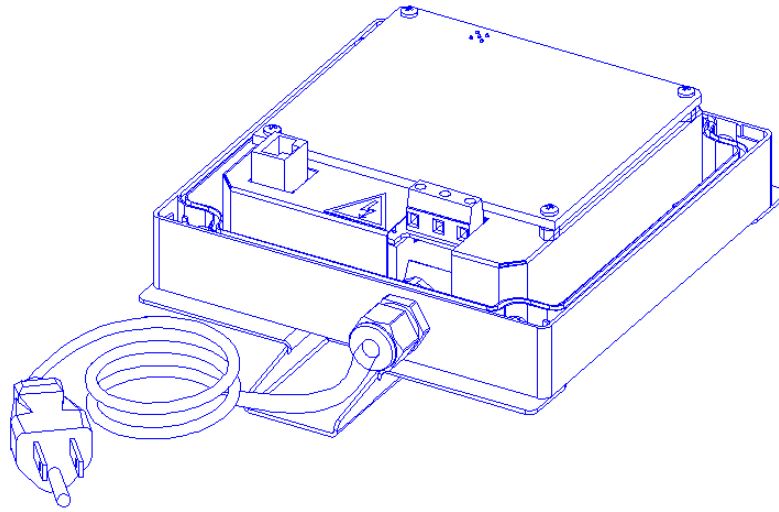

Assemble **AC cable** with screws

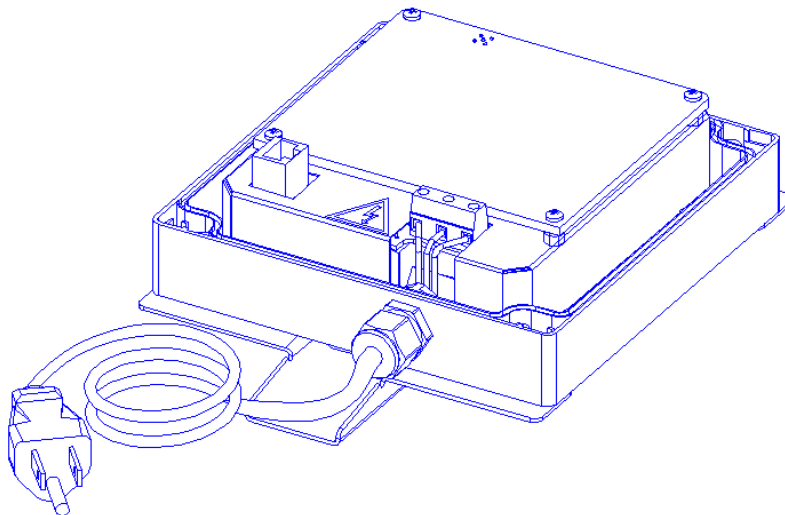

	<b>DRAW NO.:</b> DC00019-001		
	<b>DESCRIPTION:</b> FINAL ASSEMBLY REPEATER RX-TX	<b>REV</b> A	SH. _11_ OF _19_

## Top Cover

Place the **top cover** on the **front box** and assemble **screws**.

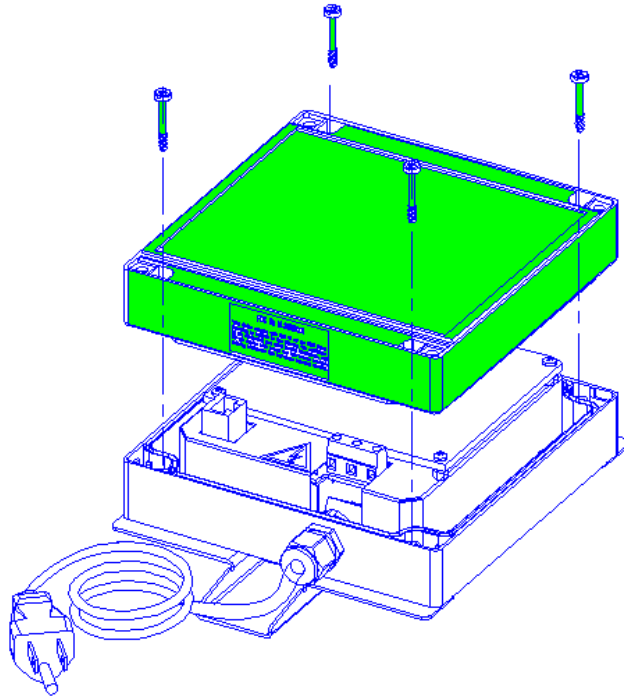

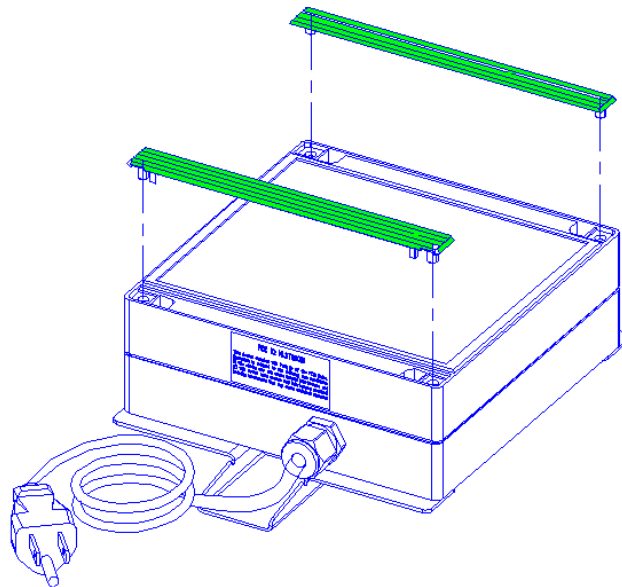

Sealed the **top cover** with **strips**.

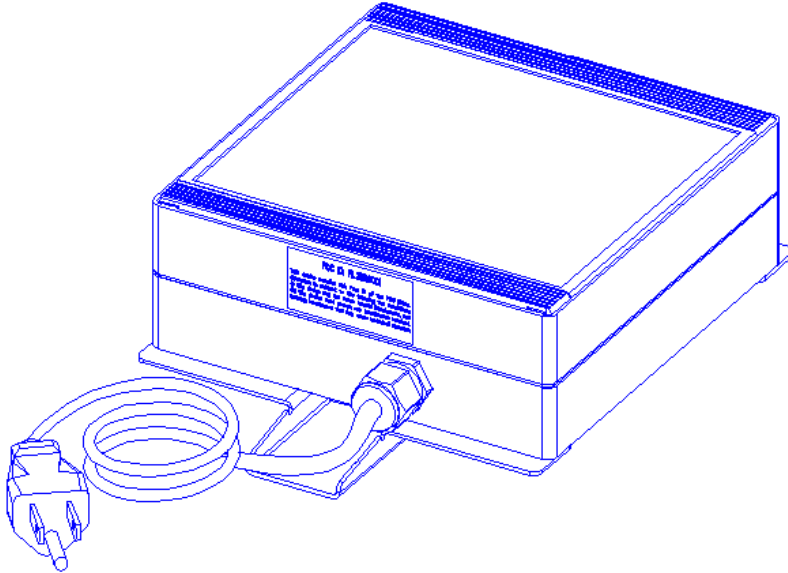

	<b>DRAW NO.:</b> DC00019-001		
	<b>DESCRIPTION:</b>  FINAL ASSEMBLY REPEATER RX-TX	<b>REV</b>  A	SH. _12_ OF _19_

# Final Assembly



	<b>DRAW NO.:</b> DC00019-001		
	<b>DESCRIPTION:</b> FINAL ASSEMBLY REPEATER RX-TX	<b>REV</b> A	SH. _13_ OF _19_

## Field Installation

### General Instructions

The NTR must be installed at least 3 meters above the floor. Select the installation location in where no moving/mobile nor static objects would exist or enter into within 2 meters of the NTR surrounding, excluding the wall or pipe where the NTR is installed on.

### Installation Steps

Locate installation place, on a roof of a dominate building in the area where the NTR services are required.



	<b>DRAW NO.:</b> DC00019-001		
	<b>DESCRIPTION:</b>  FINAL ASSEMBLY REPEATER RX-TX	<b>REV</b>  A	SH. _14_ OF _19_

Mark 2 point for drilling.



	<b>DRAW NO.:</b> DC00019-001		
	<b>DESCRIPTION:</b> FINAL ASSEMBLY REPEATER RX-TX	<b>REV</b> A	SH. _15_ OF _19_

drill 2 holes.



	<b>DRAW NO.:</b> DC00019-001		
	<b>DESCRIPTION:</b>  FINAL ASSEMBLY REPEATER RX-TX	<b>REV</b>  A	SH. _16_ OF _19_



assemble screw-holders.



	<b>DRAW NO.:</b> DC00019-001		
	<b>DESCRIPTION:</b>  FINAL ASSEMBLY REPEATER RX-TX	<b>REV</b>  A	SH. _17_ OF _19_

Assemble 2 screws.



	<b>DRAW NO.:</b> DC00019-001		
	<b>DESCRIPTION:</b>  FINAL ASSEMBLY REPEATER RX-TX	<b>REV</b>  A	SH. _18_ OF _19_

NTR Final installation



	<b>DRAW NO.:</b> DC00019-001		
	<b>DESCRIPTION:</b> FINAL ASSEMBLY REPEATER RX-TX	<b>REV</b>  A	SH. _19_ OF _19_