

日本語

SVENSKA

ITALIANO

ESPAÑOL

NEDERLANDS

DEUTSCH

FRANÇAIS

ENGLISH



**marantz**<sup>®</sup> Wireless Dock for iPod  
**IS301**

User Guide

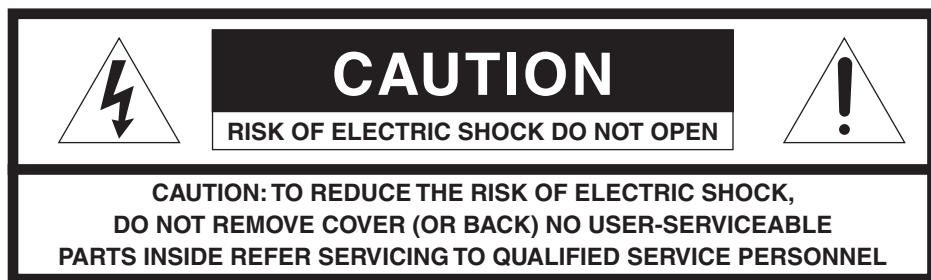

The lightning flash with arrowhead symbol within an equilateral triangle is intended to alert the user to the presence of uninsulated "dangerous voltage" within the product's enclosure that may be of sufficient magnitude to constitute a risk of electric shock to persons.



The exclamation point within an equilateral triangle is intended to alert the user to the presence of important operating and maintenance (servicing) instructions in the literature accompanying the product.

## WARNING

**TO REDUCE THE RISK OF FIRE OR ELECTRIC SHOCK,  
DO NOT EXPOSE THIS APPLIANCE TO RAIN OR MOISTURE.**

### NOTE:

This equipment has been tested and found to comply with the limits for a Class B digital device, pursuant to Part 15 of the FCC Rules. These limits are designed to provide reasonable protection against harmful interference in a residential installation. This equipment generates, uses and can radiate radio frequency energy and, if not installed and used in accordance with the instructions, may cause harmful interference to radio communications. However, there is no guarantee that interference will not occur in a particular installation. If this equipment does cause harmful interference to radio or television reception, which can be determined by turning the equipment off and on, the user is encouraged to try to correct the interference by one or more of the following measures:

Reorient or relocate the receiving antenna. Increase the separation between the equipment and receiver. Connect the equipment into an outlet on a circuit different from that to which the receiver is connected. Consult the dealer or an experienced radio/TV technician for help.

### NOTE:

**Changes or modifications may cause this unit to fail to comply with Part 15 of the FCC Rules and may void the user's authority to operate the equipment.**

**This Class B digital apparatus complies with Canadian ICES-003.**

**Cet appareil numérique de la Classe B est conforme a la norme NMB-003 du Canada.**

### FCC RADIATION EXPOSURE STATEMENT:

**This equipment complies with FCC RF radiation exposure limits set forth for an uncontrolled environment. This equipment should be installed and operated with a minimum distance of 20 centimeters between the radiator and your body.**

## Regulations According to R&TTE

### Declaration

Hereby, Marantz Europe, a division of D&M Europe B.V. declares that IS301 is in compliance with the essential requirements and other relevant provisions of Directive 1999/5/EC:

- Radio: EN 300 328
- EMC: ETSI EN 301 489-1, ETSI EN 301 489-17
- Safety: EN60950-1

### Deutsch

Hiermit erklärt **Marantz Europe, a division of D&M Europe B.V.**, dass sich dieses Gerät (IS301) in Übereinstimmung mit den grundlegenden Anforderungen und den anderen relevanten Vorschriften der Richtlinie 1999/5/EG befindet". (BMW).

### Español

Por medio de la presente **Marantz Europe, a division of D&M Europe B.V.** declara que IS301 cumple con los requisitos esenciales y cualesquiera otras disposiciones aplicables o exigibles de la Directiva 1999/5/CE.

### Français

Par la présente **Marantz Europe, a division of D&M Europe B.V.**, déclare que les appareils du type IS301 sont conformes aux exigences essentielles et aux autres dispositions pertinentes de la directive 1999/5/CE.

### Italiano

Con la presente **Marantz Europe, a division of D&M Europe B.V.**, dichiara che questo IS301 è conforme ai requisiti essenziali ed alle altre disposizioni pertinenti stabilite dalla direttiva 1999/5/CE.

### Nederlands

Hierbij verklaart **Marantz Europe, a division of D&M Europe B.V.**, dat deze IS301 in overeenstemming is met de essentiële eisen en de andere relevante bepalingen van richtlijn 1999/5/EG.

### Svenska

Härmed intygar, **Marantz Europe, a division of D&M Europe B.V.**, att denna IS301 står i överensstämmelse med de väsentliga egenskapskrav och övriga relevanta bestämmelser som framgår av direktiv 1999/5/EG.

## Declaration of Conformity(DoC)

Declaration of Conformity (DoC) of this product can be found at: <http://www.marantz.com/download/IS301>.

## Marking

In line with CE marking regulations: the CE mark and the class 2 identifier are added to the equipment:



# IMPORTANT SAFETY INSTRUCTIONS

## READ BEFORE OPERATING EQUIPMENT

This product was designed and manufactured to meet strict quality and safety standards.

There are, however, some installation and operation precautions which you should be particularly aware of.

1. Read these instructions.
2. Keep these instructions.
3. Heed all warnings.
4. Follow all instructions.
5. Do not use this apparatus near water.
6. Clean only with dry cloth.
7. Do not block any ventilation openings. Install in accordance with the manufacture's instructions.
8. Do not install near any heat sources such as radiators, heat registers, stoves, or other apparatus (including amplifiers) that produce heat.
9. Do not defeat the safety purpose of the polarized or grounding-type plug. A polarized plug has two blades with one wider than the other. A grounding type plug has two blades and a third grounding prong. The wide blade or the third prong are provided for your safety. If the provided plug does not fit into your outlet, consult an electrician for replacement of the obsolete outlet.
10. Protect the power cord from being walked on or pinched particularly at plugs, convenience receptacles, and the point where they exit from the apparatus.
11. Only use attachments/accessories specified by the manufacturer.
12. Use only with the cart, stand, tripod, bracket, or table specified by the manufacturer, or sold with the apparatus. When a cart is used, use caution when moving the cart/apparatus combination to avoid injury from tip-over.  

13. Unplug this apparatus during lightning storms or when unused for long periods of time.
14. Refer all servicing to qualified service personnel. Servicing is required when the apparatus has been damaged in any way, such as power-supply cord or plug is damaged, liquid has been spilled or objects have fallen into the apparatus, the apparatus has been exposed to rain or moisture, does not operate normally, or has been dropped.

## ENGLISH

### WARRANTY

For warranty information, contact your local Marantz distributor.

### RETAIN YOUR PURCHASE RECEIPT

Your purchase receipt is your permanent record of a valuable purchase. It should be kept in a safe place to be referred to as necessary for insurance purposes or when corresponding with Marantz.

### IMPORTANT

When seeking warranty service, it is the responsibility of the consumer to establish proof and date of purchase. Your purchase receipt or invoice is adequate for such proof.

### FOR U.K. ONLY

This undertaking is in addition to a consumer's statutory rights and does not affect those rights in any way.

## FRANÇAIS

### GARANTIE

Pour des informations sur la garantie, contacter le distributeur local Marantz.

### CONSERVER L'ATTESTATION D'ACHAT

L'attestation d'achat est la preuve permanente d'un achat de valeur. La conserver en lieu sur pour s'y reporter aux fins d'obtention d'une couverture d'assurance ou dans le cadre de correspondances avec Marantz.

### IMPORTANT

Pour l'obtention d'un service couvert par la garantie, il incombe au client d'établir la preuve de l'achat et d'en corroborer la date. Le reçu ou la facture constituent des preuves suffisantes.

## DEUTSCH

### GARANTIE

Bei Garantiefragen wenden Sie sich bitte an Ihren Marantz-Händler.

### HEBEN SIE IHRE QUITTING GUT AUF

Die Quittung dient Ihnen als bleibende Unterlage für Ihren wertvollen Einkauf. Das Aufbewahren der Quittung ist wichtig, da die darin enthaltenen Angaben für Versicherungszwecke oder bei Korrespondenz mit Marantz angeführt werden müssen.

### WICHTIG!

Bei Garantiefragen muß der Kunde eine Kaufunterlage mit Kaufdatum vorlegen. Ihren Quittung oder Rechnung ist als Unterlage ausreichend.

## NEDERLANDS

### GARANTIE

Voor inlichtingen omtrent garantie dient u zich tot uw plaatselijke Marantz.

### UW KWITANTIE, KASSABON E.D. BEWAREN

Uw kwitantie, kassabon e.d. vormen uw bewijs van aankoop van een waardevol artikel en dienen op een veilige plaats bewaard te worden voor evt. verwijzing bijv. in verband met verzekering of bij correspondentie met Marantz.

### BELANGRIJK

Bij een evt. beroep op de garantie is het de verantwoordelijkheid van de consument een gedateerd bewijs van aankoop te tonen. Uw kassabon of factuur zijn voldoende bewijs.

## ESPAÑOL

### GARANTIA

Para obtener información acerca de la garantía póngase en contacto con su distribuidor Marantz.

### GUARDE SU RECIBO DE COMPRA

Su recibo de compra es su prueba permanente de haber adquirido un aparato de valor. Este recibo deberá guardarlo en un lugar seguro y utilizarlo como referencia cuando tenga que hacer uso del seguro o se ponga en contacto con Marantz.

### IMPORTANTE

Cuando solicite el servicio otorgado por la garantía el usuario tiene la responsabilidad de demostrar cuándo efectuó la compra. En este caso, su recibo de compra será la prueba apropiada.

## ITALIANO

### GARANZIA

L'apparecchio è coperto da una garanzia di buon funzionamento della durata di un anno, o del periodo previsto dalla legge, a partire dalla data di acquisto comprovata da un documento attestante il nominativo del Rivenditore e la data di vendita. La garanzia sarà prestata con la sostituzione o la riparazione gratuita delle parti difettose.

Non sono coperti da garanzia difetti derivanti da uso improprio, errata installazione, manutenzione effettuata da personale non autorizzato o, comunque, da circostanze che non possano riferirsi a difetti di funzionamento dell'apparecchio. Sono inoltre esclusi dalla garanzia gli interventi inerenti l'installazione e l'allacciamento agli impianti di alimentazione.

Gli apparecchi verranno riparati presso i nostri Centri di Assistenza Autorizzati. Le spese ed i rischi di trasporto sono a carico del cliente.

La casa costruttrice declina ogni responsabilità per danni diretti o indiretti provocati dalla inosservanza delle prescrizioni di installazione, uso e manutenzione dettagliate nel presente manuale o per guasti dovuti ad uso continuato a fini professionali.

## SVENSKA

### GARANTI

För information om garantin, kontakta Marantz lokalt.

### SPAR KVITTON

Kvitton är ett inköpsbevis på en värdefull vara. Det skall förvaras säkert och hänvisas till vid försäkringsfall eller vid korrespondens med Marantz.

### VIKTIGT

Fö att garantin skall gälla är det kundens sak att framställa bevis och datum om köpet. Kvitto eller faktura är tillräckligt bevis för detta.

## English

### WARNINGS

- Do not expose the equipment to rain, moisture, dripping or splashing.
- Do not handle the AC adaptor with wet hands.
- Do not cover the ventilation with any items such as tablecloths, newspapers, curtains, etc.
- No naked flame sources, such as lighted candles, should be placed on the equipment.
- When disposing of used batteries, please comply with governmental regulations or environmental public instruction's rules that apply in your country or area.
- Make a space of about 0.2 meter around the unit.
- No objects filled with liquids, such as vases, shall be placed on the equipment.
- When the switch is in the OFF position, the equipment is not completely switched off from MAINS.
- The equipment shall be installed near the power supply so that the power supply is easily accessible.
- Do not expose the unit and batteries to excessive heat such as direct sunlight, fire or the like.

## Français

### AVERTISSEMENTS

- Ne pas exposer l'appareil à la pluie, à l'humidité, à l'égouttement ou aux éclaboussures.
- Ne pas manipuler l'adaptateur secteur avec les mains humides.
- Ne pas recouvrir les ouïes de ventilation avec un objet quelconque comme une nappe, un journal, un rideau, etc.
- Ne placer aucune source de flamme nue, comme une bougie allumée, sur l'appareil.
- Pour mettre au rebut les piles usées, respecter les lois gouvernementales ou les règlements officiels concernant l'environnement qui s'appliquent à votre pays ou région.
- Veiller à ce qu'aucun objet ne soit à moins de 0,2 mètre des côtés de l'appareil.
- Aucun objet rempli de liquide, un vase par exemple, ne doit être placé sur l'appareil.
- Lorsque l'interrupteur est sur la position OFF, l'appareil n'est pas complètement déconnecté du SECTEUR (MAINS).
- L'appareil sera installé près de la source d'alimentation, de sorte que cette dernière soit facilement accessible.
- N'exposez pas l'appareil et les piles à une chaleur excessive, comme par exemple aux rayons directs du soleil, au feu, etc.

## Deutsch

### WARNHINWEISE

- Das Gerät nicht Regen, Feuchtigkeit, Tropf- oder Spritzwasser aussetzen.
- Berühren Sie den Netzadapter nicht mit nassen Händen.
- Decken Sie die Lüftungsöffnungen nicht mit einem Tischtuch, einer Zeitung, einem Vorhang usw. ab.
- Es dürfen keine Gegenstände mit offener Flamme, wie etwa brennende Kerzen, auf dem Gerät aufgestellt werden.
- Beachten Sie bei der Entsorgung der verbrauchten Batterien alle geltenden lokalen und überregionalen Regelungen.
- Auf allen Geräteseiten muß ein Zwischenraum von ungefähr 0,2 meter vorhanden sein.
- Auf das Gerät dürfen keine mit Flüssigkeiten gefüllte Behälter, wie etwa eine Vase, gestellt werden.
- Wenn der Schalter ausgeschaltet ist (OFF-Position), ist das Gerät nicht vollständig vom Stromnetz (MAINS) abgetrennt.
- Das Gerät sollte in der Nähe einer Netzsteckdose aufgestellt werden, damit es leicht an das Stromnetz angeschlossen werden kann.
- Setzen Sie das Gerät und die Batterien keiner übermäßigen Wärme aus, z.B. durch Aufstellung in direkter Sonneneinstrahlung, in der Nähe eines offenen Feuers usw.

## Nederlands

### WAARSCHUWINGEN

- Stel het apparaat niet bloot aan regen, vocht, druppels of spetters.
- Raak de wisselstroomadapter niet aan met natte handen.
- Bedek de ventilatieopeningen niet met enige voorwerpen, zoals tafelkleden, kranten, gordijnen, enz.
- Plaats geen brandende voorwerpen, zoals kaarsen, op het apparaat.
- Volg bij het weggooiën van verbruikte batterijen de overheidswetgeving of milieuvoorschriften op die van kracht zijn in het land of de regio waarin u zich bevindt.
- Zorg dat er 0,2 meter vrije ruimte rond het toestel is.
- Plaats geen voorwerpen met een vloeistof erin, zoals een bloemenvaas, op het apparaat.
- Als de schakelaar op OFF staat, is het apparaat niet volledig losgekoppeld van de netspanning (MAINS).
- De apparatuur wordt in de buurt van het stopcontact geïnstalleerd, zodat dit altijd gemakkelijk toegankelijk is.
- Stel het apparaat en de batterijen niet bloot aan grote warmte, zoals direct zonlicht, vuur en dergelijke.

## Español

### ADVERTENCIAS

- No exponga el equipo a la lluvia, la humedad, goteos o salpicaduras.
- No toque el adaptador de CA con las manos húmedas.
- No cubra la ventilación con objetos como manteles, periódicos, cortinas, etc.
- No deben colocarse sobre el equipo elementos con fuego, por ejemplo velas encendidas.
- Cuando se eliminen baterías usadas, deben cumplirse las reglamentaciones oficiales o las normas de protección medioambiental aplicables en su país o en su zona.
- Deje un espacio de unos 0,2 metro alrededor de la unidad.
- No se deben colocar sobre el aparato recipientes que contengan líquidos, como por ejemplo jarrones.
- Cuando el interruptor está en la posición OFF, el equipo no está completamente desconectado de la alimentación MAINS.
- El equipo se instalará cerca de la fuente de alimentación de manera que resulte fácil acceder a ella.
- No exponga la unidad y las pilas a un calor excesivo, tal como el derivado de la luz directa del sol, el fuego, o alguna fuente térmica similar.

## Italiano

### AVVERTENZE

- Non esporre l'apparecchio alla pioggia, all'umidità, al gocciolamento o agli spruzzi.
- Non toccare l'adattatore CA con le mani bagnate.
- Non coprire le fessure di ventilazione con tovaglie, giornali, tende od oggetti analoghi.
- Non posare sull'apparecchio sorgenti di fiamme scoperte quali candele accese.
- Smaltire le pile usate in conformità alle norme governative o disposizioni ambientali vigenti nel proprio paese o zona.
- Lasciare 0,2 metro liberi tutto intorno l'unità.
- Non mettere sull'apparecchiatura alcun contenitore di liquido, come ad esempio dei vasi.
- Quando l'interruttore è nella posizione OFF, l'apparecchiatura non è completamente scollegata da MAINS.
- L'apparecchio va installato in prossimità della fonte di alimentazione, in modo che quest'ultima sia facilmente accessibile.
- Non esporre l'unità e le batterie a calore eccessivo come la luce diretta del sole, il fuoco o così via.

## Svenska

### VARNINGAR

- Utsätt inte utrustningen för regn, fukt, droppande vatten eller vattenstänk.
- Hantera inte nätadaptern med våta händer.
- Täck inte för ventilationsöppningarna med några föremål som till exempel bordsdukar, dagstidningar, gardiner e.d.
- Inga föremål med öppen låga, som till exempel tända stearinljus, bör placeras på utrustningen.
- Följ de lagar och miljöskyddsråd som gäller i det land eller område där du bor när du gör dig av med batterier.
- Se till att det finns omkring 0,2 meter fri plats runt omkring enheten.
- Inga objekt som är fyllda med någon vätska, till exempel blomstervaser, bör placeras på apparaten.
- Även om strömbrytaren står i det avstängda läget OFF, så är utrustningen inte helt bortkopplad från det elektriska nätet (MAINS).
- Utrustningen ska vara installerad nära strömuttaget så att strömförsörjningen är lätt att tillgå.
- Utsätt inte enheten och batterierna för kraftig värme, såsom direkt solljus, eld eller liknande.

## ENGLISH

### A NOTE ABOUT RECYCLING

This product's packaging materials are recyclable and can be reused. This product and the accessories packed together are the applicable product to the WEEE directive except batteries. Please dispose of any materials in accordance with your local recycling regulations. When discarding the unit, comply with your local rules or regulations. Batteries should never be thrown away or incinerated but disposed of in accordance with your local regulations concerning chemical wastes.



## FRANÇAIS

### REMARQUE CONCERNANT LE RECYCLAGE

Le matériel d'emballage de cet appareil est recyclable et peut être réutilisé. Cet appareil et les accessoires qui sont emballés avec celui-ci sont conformes, à l'exception des piles, à la directive DEEE (relative aux déchets d'équipements électriques et électroniques). Jetez ce matériel conformément aux réglementations de recyclage locales. Pour mettre l'appareil au rebut, respectez les règles ou réglementations locales. Les piles ne doivent jamais être jetées ou incinérées, mais être mises au rebut conformément aux réglementations locales concernant les déchets chimiques.



## DEUTSCH

### RECYCLING-HINWEIS

Das Verpackungsmaterial dieses Produkts ist für Recycling geeignet und kann wiederverwendet werden. Dieses Produkt und das in seinem Verpackungskarton enthaltene Zubehör mit Ausnahme der Batterien entsprechen der WEEE-Direktive. Bitte beachten Sie bei der Entsorgung irgendwelcher Materialien die örtlichen Recycling-Bestimmungen. Bei der Entsorgung des Gerätes sind die einschlägigen Umweltschutzaufgaben sorgfältig zu befolgen. Batterien dürfen nicht weggeworfen oder verbrannt werden, sondern müssen gemäß den örtlichen Vorschriften zur Entsorgung von chemischem Abfall entsorgt werden.



## NEDERLANDS

### RECYCLING VAN APPARATUUR EN VERPAKKINGSMATERIAAL

De verpakking van dit product is geschikt voor recycling. Dit product en de accessoires, als geheel verpakt, zijn het relevante product volgens de WEEE-richtlijn, behalve de batterijen. Gooi materialen bij het afval volgens de gemeentelijke voorschriften voor recycling. Gooi dit apparaat bij het afval volgens de gemeentelijke wetten of voorschriften. Batterijen mogen nooit bij het normale afval en mogen nooit worden verbrand, maar moeten worden weggegooid volgens de gemeentelijke voorschriften voor chemisch afval.



## ESPAÑOL

### NOTA SOBRE EL RECICLADO

Los materiales de embalaje de este producto son reciclables y pueden ser reutilizados. En este producto y sus accesorios incluidos es aplicable la directiva europea sobre residuos de aparatos eléctricos y electrónicos (RAEE), excepto en lo referente a las pilas. Se ruega eliminar cualquiera de esos materiales de acuerdo con las normas locales de reciclado. Cuando deseche esta unidad, cumpla con las normas o reglamentaciones locales. Las pilas no deben tirarse ni incinerarse, sino que deben eliminarse de acuerdo con las normas locales sobre residuos químicos.



## ITALIANO

### NOTA SUL RICICLAGGIO

I materiali di imballaggio di questo prodotto sono riciclabili e possono essere riutilizzati. Questo prodotto e gli accessori in dotazione con esso, eccettuate le batterie, rappresentano il prodotto applicabile per la direttiva RAEE (rifiuti di apparecchiature elettriche ed elettroniche). Smaltirli seguendo le proprie normative locali sul riciclaggio. Quando si desidera eliminare l'apparecchio, attenersi alle indicazioni e alle normative locali. Non gettare via le batterie e non bruciarle, ma smaltirle in conformità alle normative locali relative ai rifiuti chimici.



## SVENSKA

### OM ÅTERVINNING

Den här produktens förpackningsmaterial är återvinningsbart och kan återanvändas. Den här produkten och de med produkten levererade tillbehören, förutom batterierna, överensstämmer med WEEE-direktivet. Kassera allt material i enlighet med lokala miljöföreskrifter. När enheten ska kasseras ska du följa lokala miljöföreskrifter. Batterier får aldrig slängas i hushållsavfall eller brännas. Dom ska hanteras i enlighet med lokala miljöföreskrifter för kemiskt avfall.



# 安全上のご注意

ご使用前に、この「安全上のご注意」をよくお読みになり、正しくお使いください。  
お読みになったあとは、いつでも見られる場所に保証書と共に必ず保管してください。

## 絵表示について

この「安全上のご注意」は、製品を安全に正しくお使いいただき、あなたや他の人々への危害や財産への損害を未然に防止するため、いろいろな絵表示をしています。内容をよく理解してから本文をお読みください。



### 警告

この表示を無視して、誤った取扱いをすると、人が死亡または重傷を負う可能性が想定される内容を示しています。



### 注意

この表示を無視して、誤った取扱いをすると、人が傷害を負う可能性が想定される内容および物的損害のみの発生が想定される内容を示しています。



⊘記号は禁止の行為であることを告げるものです。

図の中や近傍に具体的な禁止内容(左図の場合は分解禁止)が描かれています。



●記号は行為を強制したり指示する内容を告げるものです。

図の中に具体的な指示内容(左図の場合は電源プラグをコンセントから抜く)が描かれています。



△記号は注意を促す内容があることを告げるものです。

図の中に具体的な注意内容(左図の場合は指をはさまれないように注意)が描かれています。



電源プラグをコンセントから抜く

- 万一、煙が出ている、変なにおいや音がするなどの異常状態のまま使用すると火災・感電の原因となります。すぐに AC アダプターをコンセントから抜いてください。煙が出なくなるのを確認して販売店に修理をご依頼ください。
- 万一、内部に水などが入った場合は、まず AC アダプターをコンセントから抜いて販売店にご連絡ください。そのまま使用すると火災・感電の原因となります。
- 万一、機器の内部に異物が入った場合は、まず AC アダプターをコンセントから抜いて販売店にご連絡ください。そのまま使用すると火災・感電の原因となります。
- 万一、この機器を落したり、キャビネットを破損した場合は、AC アダプターをコンセントから抜いて販売店にご連絡ください。そのまま使用すると火災・感電の原因となります。



水場での使用禁止

- 風呂場や窓ぎわで雨などがかかるおそれのある所等の水滴がかかる場所では使用しないでください。火災・感電の原因となります。



## 警告



- 表示された電源電圧(交流 100 ボルト)以外の電圧で AC アダプターを使用しないでください。火災・感電の原因となります。
- この機器を使用できるのは日本国内のみです。電源周波数は 50Hz 地域または 60Hz 地域でご使用できます。船舶などの直流(DC)電源には接続しないでください。火災の原因となります。
- この機器の上でろうそく等の炎が発生しているものを置かないでください。火災の原因となります。
- この機器の上に花びん、植木鉢、コップ、化粧品、薬品や水などの入った容器や小さな金属物を置かないでください。こぼれたり、中に入った場合火災・感電の原因となります。
- エアコンの下に置かないでください。エアコンから水滴が滴下した場合、汚損・故障・火災・感電の原因となります。



接触禁止

- 雷が鳴り出したら、AC アダプターには触れないでください。感電の原因となります。



- この機器に水が入ったり、ぬらさないようにご注意ください。火災・感電の原因となります。雨天、降雪中、海岸、水辺での使用は特にご注意ください。



分解禁止



- この機器の裏ふた、キャビネット、カバーは絶対外さないでください。内部には電圧の高い部分があり、感電の原因となります。内部の点検・整備・修理は販売店にご依頼ください。
- この機器を改造しないでください。火災・感電の原因となります。



## 電波に関する注意事項

本機の使用周波数帯(2.4GHz帯)では、電子レンジ等の産業・科学・医療用機器のほか工場の製造ライン等で使用されている移動体識別用の構内無線局(免許を要する無線局)及び特定小電力無線局(免許を要しない無線局)並びにアマチュア無線局(免許を要する無線局)が運用されています。

1. 本機を使用する前に、近くで移動体識別用の構内無線局及び特定小電力無線局並びにアマチュア無線局が運用されていないことを確認して下さい。
2. 万一、本機から移動体識別用の構内無線局に対して有害な電波干渉の事例が発生した場合には、速やかに本機の使用場所を変えるか、又は電波の発射を停止の上、当社お客様ご相談センター(連絡先は同梱の製品のご相談と修理・サービス窓口のご案内参照)にご連絡頂き、混信回避のための処置等についてご相談して下さい。
3. その他、この機器から移動体識別用の特定小電力無線局あるいはアマチュア無線局に対して有害な電波干渉の事例が発生した場合など何かお困りのことがおきたときは、当社お客様ご相談センター(連絡先は同梱の製品のご相談と修理・サービス窓口のご案内参照)へお問い合わせ下さい。

	2.4	: 2.4GHz帯を使用する無線設備を表す
	FH	: 変調方式としてFH-SS方式を使用することを表す
	1	: 想定される干渉距離が10m以下であることを表す
		: 全帯域を使用します。

- 本機の分解、改造は電波法で禁止されております。分解・改造は絶対に行なわないでください。
- 本機は電波法に基づく、技術基準適合証明等を取得した無線機器です。技適マークがついています。この技適マークをはがさないでください。技適ラベルをはがすと、技術基準適合機としての効力を失い、使用できなくなります。



- オーディオ機器を接続する場合は、各々の機器の取扱説明書をよく読み、ACアダプターをコンセントに接続する前に、説明に従って接続してください。また、接続は指定のコードを使用してください。指定以外のコードを使用したり、コードを延長したりすると発熱しやけどの原因となることがあります。
- 製品に同梱しているACアダプターのみ使用してください。製品に同梱していないACアダプターは使用しないでください。火災・感電の原因となります。



電源プラグをコンセントから抜く

- 旅行などで長期間、この機器をご使用にならないときは安全のため必ずACアダプターをコンセントから抜いてください。
- お手入れの際は安全のためACアダプターをコンセントから抜いて行ってください。
- 移動させる場合は、ACアダプターをコンセントから抜き、機器間の接続コードなど外部の接続コードを外してから行ってください。ACアダプターが傷つき、火災・感電の原因となることがあります。



注意



- 調理台や加湿器のそばなど油煙や湯気が当たるような場所に置かないでください。火災・感電の原因となることがあります。
- ぐらついた台の上や傾いた所など不安定な場所や振動のある所に置かないでください。落ちたり、倒れたりしてけがの原因となることがあります。
- ACアダプターを熱器具に近づけないでください。コードの被ふくが溶けて、火災・感電の原因となることがあります。
- この機器または電池が入ったりリモコンを次のような異常に温度が高くなる場所に放置しないでください。キャビネットや部品に悪い影響を与え、火災の原因となることがあります。  
窓を閉めきった自動車の中  
直射日光が当たる場所  
火や暖房器具など熱を発生する機器の近く
- 湿気やほこりの多い場所に置かないでください。火災・感電の原因となることがあります。



- 濡れた手でACアダプターを抜き差ししないでください。感電の原因となることがあります。



- 5年に一度くらいは機器内部の掃除を販売店などにご相談ください。機器の内部にほこりがたまったまま、長い間掃除をしないと火災や故障の原因となることがあります。特に、湿気の多くなる梅雨期の前に行くと、より効果的です。なお、掃除費用については販売店などにご相談ください。

Thank you for purchasing the Marantz IS301 Wireless Dock for iPod.  
 This remarkable component has been engineered to provide you with many years of listening enjoyment. Please take a few minutes to read this manual thoroughly before you connect and operate the IS301.  
 As there are a number of connection and configuration options, you are encouraged to discuss your own particular system setup with your Marantz authorized dealer.

# CONTENTS

<b>CONTENTS</b> .....	<b>1</b>
<b>FEATURES</b> .....	<b>2</b>
<b>BEFORE USE</b> .....	<b>2</b>
CONNECTABLE iPod PRODUCTS .....	2
CHECKING THE PRODUCT AND ACCESSORIES .....	2
HANDSET (IS301).....	4
BASE UNIT (IS301DS) .....	5
EXTENDER (IS301RX) .....	6
WIRELESS CONNECTIONS.....	7
IS-LINK CONNECTIONS .....	12
CONNECTING THE EXTENDER WITH OTHER BLUETOOTH DEVICES .....	14
MOUNTING ON A WALL .....	15
USE OF THE REMOTE.....	18
CONTROLLER (RC001IS) .....	18
<b>TROUBLESHOOTING</b> .....	<b>20</b>
<b>OTHERS</b> .....	<b>20</b>
SPECIFICATIONS .....	21



## FEATURES

- By connecting an iPod and your home audio equipment via this unit, you can play back audio files in the iPod with your audio equipment.
- According to your purposes and environment of use, either wireless connection or wired connection can be selected.
- Thanks to audio wireless transmission technologies using the Bluetooth® A2DP profile, the handset and extender can be used via wireless connection.
- Thanks to wireless remote control technologies using the Bluetooth AVRCP Profile, you can remotely control Marantz audio amplifiers and other equipment that supports the Bluetooth AVRCP Profile.
- This unit supports the SCMS-T content protection method for Bluetooth. (IS301RX)
- Thanks to the secure chip that is built into this unit for content protection, video signals can be output from an iPod.
- Thanks to the thickness adjustment knob on the handset, an iPod can be attached to the handset without using a docking adaptor.
- Two methods for installing this unit are available: on the table or on the wall.
- An iPod can be easily attached or detached.
- Recharging of an iPod is possible.

## BEFORE USE

### CONNECTABLE iPod PRODUCTS

- iPod touch (first and second generations)
- iPod classic
- iPod nano (first, second, third, and fourth generations)
- iPod (fourth and fifth generations)
- iPod mini

#### Notes

- Before use, be sure to update your iPod product to the latest version.
- Visit and acquire the updater for updating your iPod to the latest version from the Web site of Apple Inc.X

## BEFORE USE

### CHECKING THE PRODUCT AND ACCESSORIES

After opening the cover of the packing box, check that the following product and accessories are included.

- Handset (IS301) ..... 1
- Antenna for the extender ..... 1

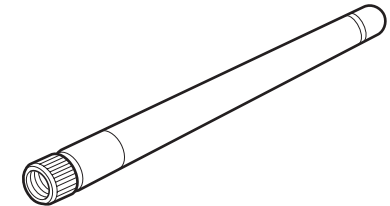
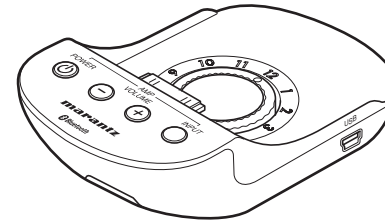

- Base unit (IS301DS)..... 1

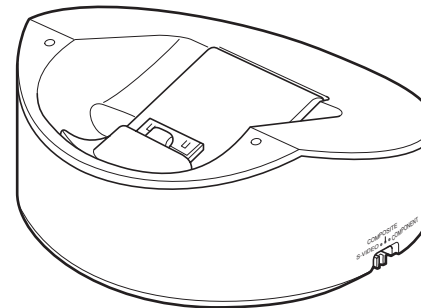

- Remote controller (RC001IS)..... 1

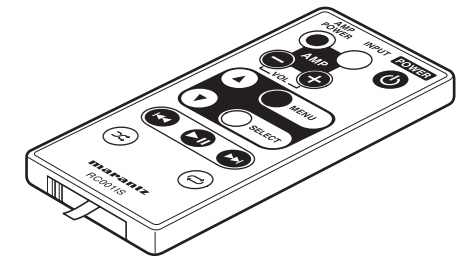

- AC adaptors (for the base unit and extender) .. 2

- Extender (IS301RX)..... 1

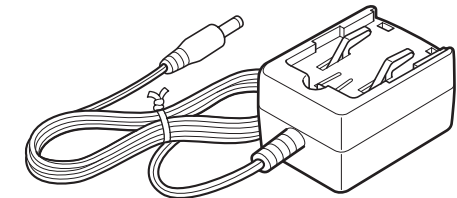
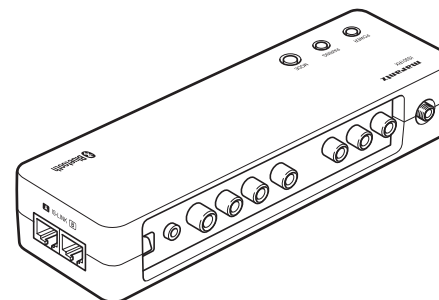

BEFORE USE

- Power plugs for the AC adaptors
  - For the U.S.A./Japan ..... 2

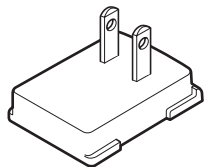

- For the U.K. .... 2

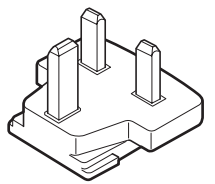

- For Europe ..... 2

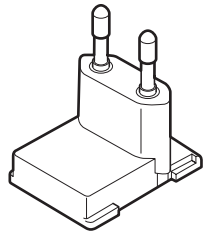

- For Australia ..... 2

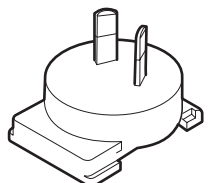

- IS-LINK cables (CAT5/LAN straight-type cables) ... 2

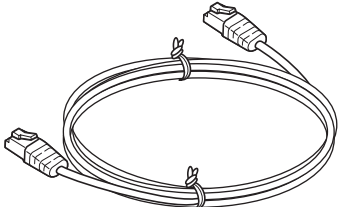

- AV cable ..... 1

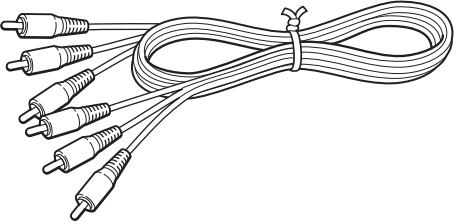

- Remote cable ..... 1

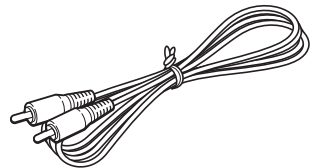

- USB cable ..... 1

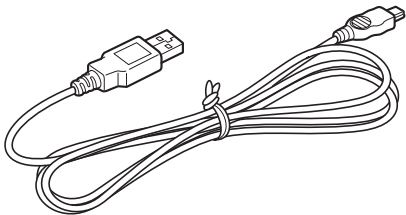

- Wall-mounting screws@@@pend@@@ ..... 1



- User Guide ..... 1

- Warranties
  - For Japan ..... 1
  - For Canada ..... 1
  - For the U.S.A. .... 1

- Label  
(Describing notes on radio waves, for Japan) .. 1

# NAMES AND FUNCTIONS

## HANDSET (IS301)

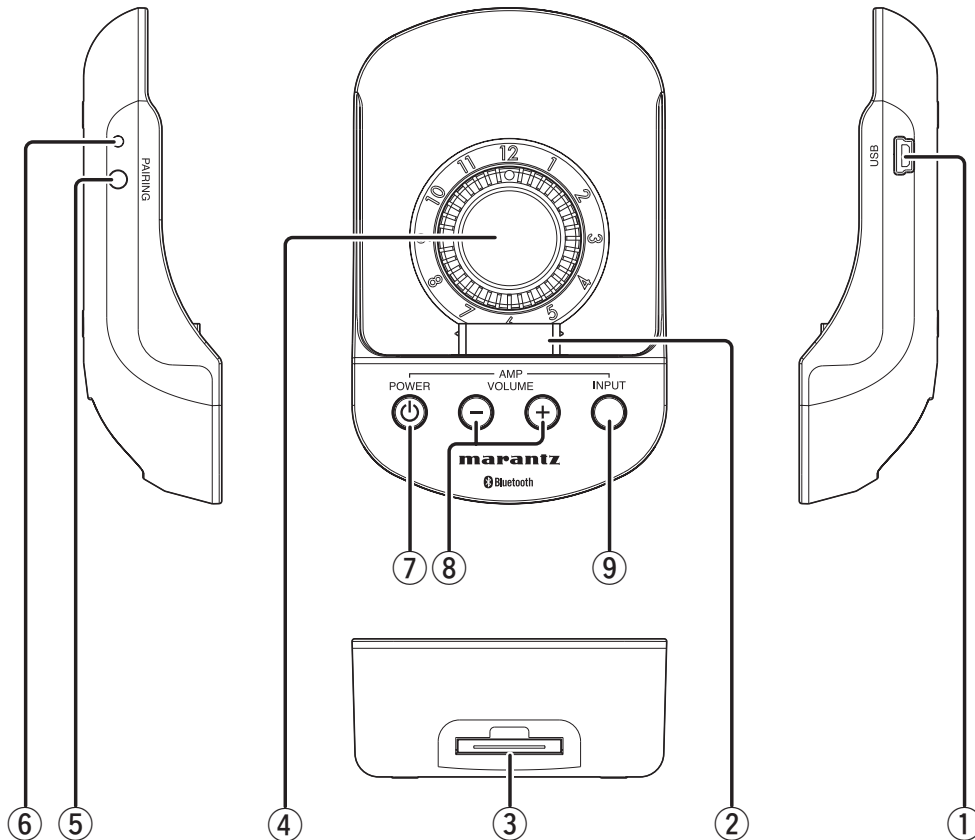

### ① USB connector

Connect your PC, using the supplied USB cable. Synchronizing the iPod with iTunes is possible with your iPod docked in the handset.

### ② iPod docking connector

Connect the docking connector of the iPod.

### ③ Base connector

Connect the Handset connector of the base unit.

### ④ Thickness adjustment knob

Turn this knob to adjust the thickness, according to the thickness of your iPod product. Inappropriate thickness adjustment may result in damage to the connectors.

For details, see "CONNECTING YOUR IPOD WITH THE HANDSET" (page XX).

### ⑤ PAIRING button

Use this button to establish Bluetooth connection with the extender.

### ⑥ PAIRING indicator

This indicates connection status with the extender with lighting/flashing and colors.

### ⑦ POWER button (AMP control buttons)

This button turns ON/OFF the Marantz amplifier/receiver that is remotely connected with this unit.

### ⑧ VOL +/- buttons (AMP control buttons)

This button increases/decreases the volume of the Marantz amplifier/receiver that is remotely connected with this unit.

### ⑨ INPUT button (AMP control buttons)

This button switches the input sources of the Marantz amplifier/AV receiver that is remotely connected with this unit.

(Some models cannot be remotely controlled with this button.)

**BASE UNIT (IS301DS)**

**TOP VIEW**

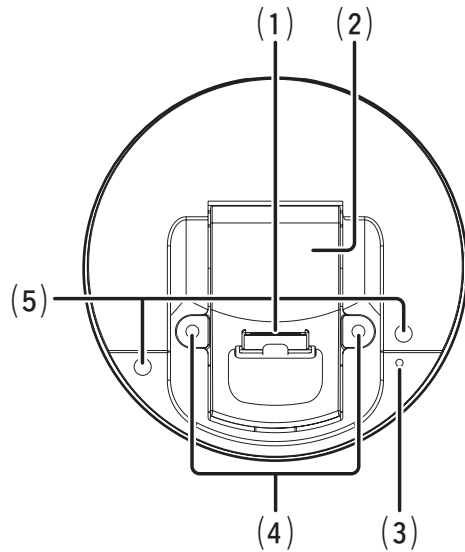

**SIDE AND BOTTOM VIEWS**

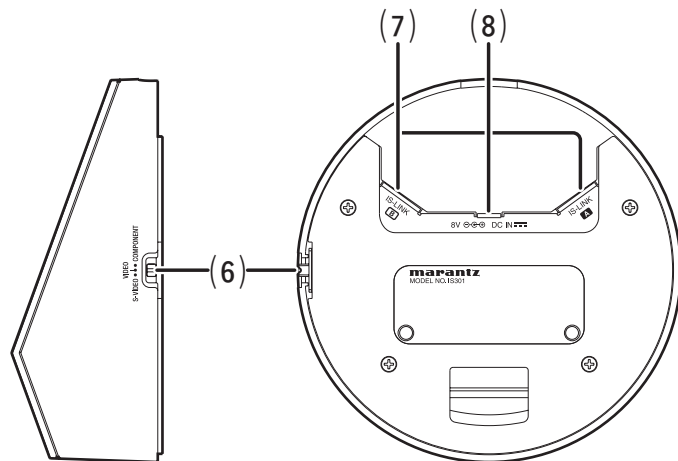

**(1) Handset connector**

Connect the handset here.

**Note**

NEVER connect an iPod directly with this connector, because the shape of this connector is different from the docking connector of the iPods.

**(2) Handset holder**

When the base unit is mounted on a wall, raise this holder. For details, see page XX.

**(3) Power indicator**

This indicator lights when power is supplied from the AC adaptor or when the base unit is connected with the powered extender via the IS-LINK cable. It flashes when an infrared signal from the remote controller is received.

**(4) Holes for wall mounting**

Use these holes when mounting the base unit on a wall.

**(5) Infrared signal reception window**

This is the reception window for infrared signals from the remote controller.

**(6) Video selection switch**

Select video signals (S-VIDEO/VIDEO/COMPONENT) that are output from the extender.

**(7) IS-LINK A/B terminals**

Used to connect the base unit and the extender via the supplied IS-LINK cables. Before connection, unplug the power cord then check that the connections to the IS-LINK A and B terminals are properly made.

**(8) AC adaptor terminal**

Connect the supplied AC adaptor. If an IS-LINK cable is connected to the IS-LINK A terminal, power will be supplied from the extender. Therefore, it is not required to connect the AC adaptor to the base unit.

**NAMES AND FUNCTIONS**

**EXTENDER (IS301RX)**

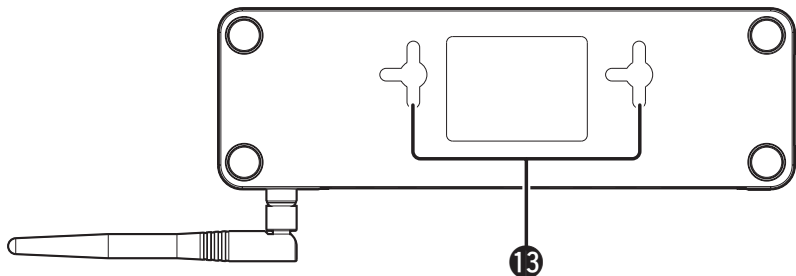
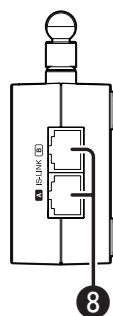
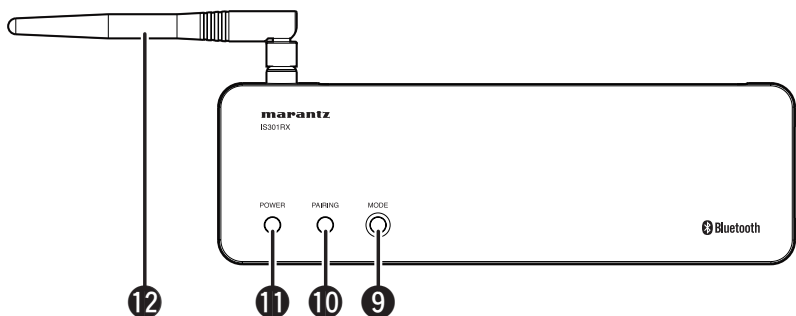
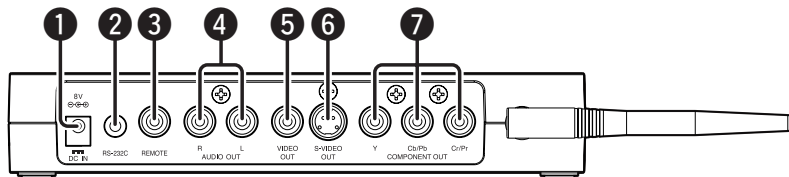

**1 AC adaptor terminal**

Connect the supplied AC adaptor.

**2 RS-232C terminal**

Used to connect an external control system.

**3 REMOTE terminal**

Connect to a Marantz product equipped with a remote control terminal.

**4 AUDIO OUT L/R terminals**

Connect to the audio input terminals of an amplifier/receiver/TV.

**5 VIDEO OUT terminal**

Connect to the video input terminal of a receiver/TV.

**6 S-VIDEO OUT terminal**

Connect to the S-VIDEO input terminal of a receiver/TV.

**7 COMPONENT (Y, Cb/Pb, Cr/Pr) VIDEO OUT terminals**

Connect to the component video input terminals of a receiver/TV.

**8 IS-LINK A/B terminals**

Used to connect the base unit and the extender via the supplied IS-LINK cables. Connect the supplied IS-LINK cables. Before connection, unplug the power cord then check that the connections to the IS-LINK A and B terminals are properly made.

**9 MODE button**

Use this button to establish a wireless connection between the handset and extender.

**10 PAIRING indicator**

Use this button to establish a wireless connection between the handset and extender. This indicates connection status with the handset with lighting/flashing and colors.

**11 POWER indicator**

This indicator lights when the AC adaptor is connected to the extender.

**12 Antenna**

This is an antenna for wireless communication. At shipment, this antenna is packed separately from the extender. For details on how to mount on the extender, see page XX.

**13 Holes for wall mounting**

Use these holes when mounting the extender on the wall.

# BASIC OPERATIONS

## WIRELESS CONNECTIONS

### WHAT IS AVAILABLE WHEN WIRELESS CONNECTIONS ARE MADE

- Audio playback
- Remote operations of a Marantz amplifier or receiver, using the **AMP control** buttons on the handset
- Use of an iPod and the handset detached from the base unit

### WHAT IS NOT AVAILABLE WHEN WIRELESS CONNECTIONS ARE MADE

- Video playback
- Control of a Marantz amplifier, using the supplied remote controller
- Use of the base unit as an infrared signal receiver for controlling a Marantz product

## BEFORE CONNECTION

### Notes

- If the cable is connected to the IS-LINK terminals, wireless connection will not be enabled.
- If an iPod and the handset are used detached from the base unit, the handset will be powered by the built-in battery of the iPod. This makes it difficult to use them for a long duration. The operable time will differ, depending on the type of iPod products you use.

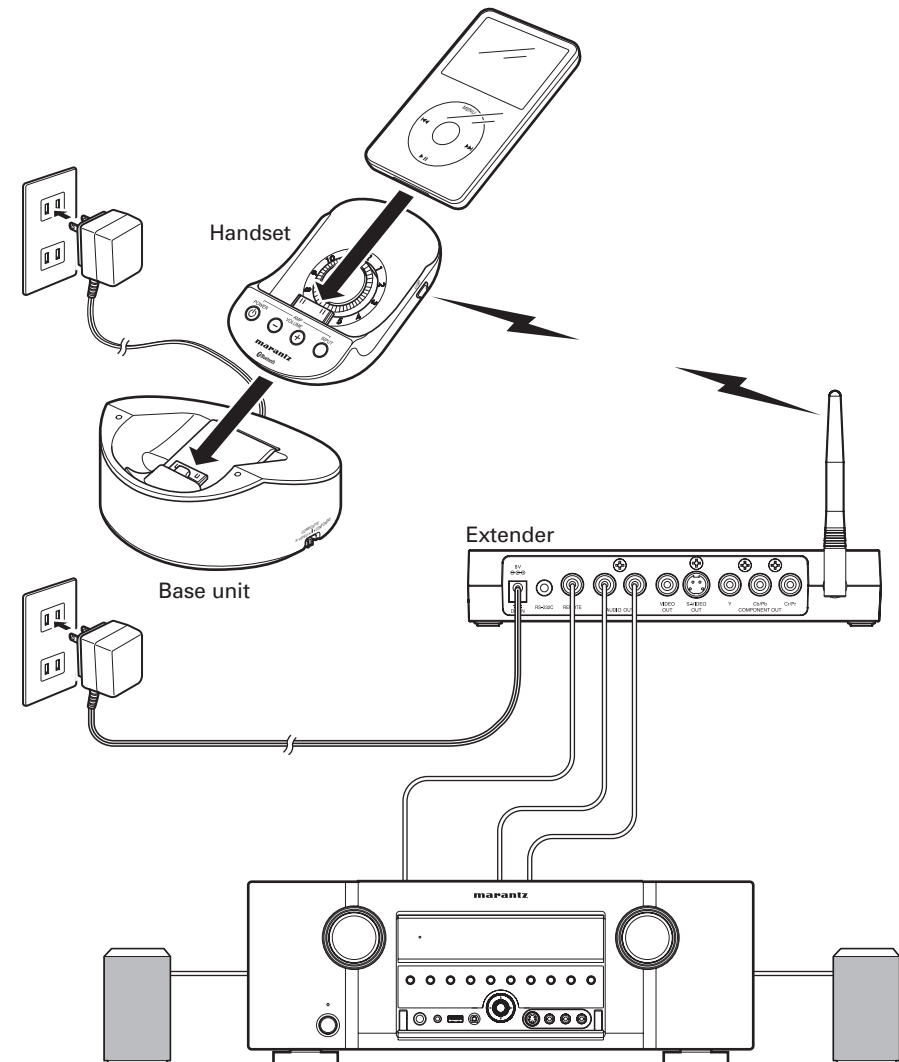



## BASIC OPERATIONS

### ① CONNECTING THE EXTENDER AND AN AMPLIFIER

1. Connect the AUDIO OUT terminals of the extender with the line input terminals of an amplifier/receiver, via the supplied AV cable.
2. If you wish to remotely control the connected amplifier/receiver using the Marantz remote control terminals, connect the REMOTE terminals of both pieces of equipment via the supplied remote cable. This connection makes it possible to operate the Marantz amplifier/receiver with the **AMP control** buttons (**POWER** button, **VOLUME +/-** buttons, and **INPUT** button) on the handset.

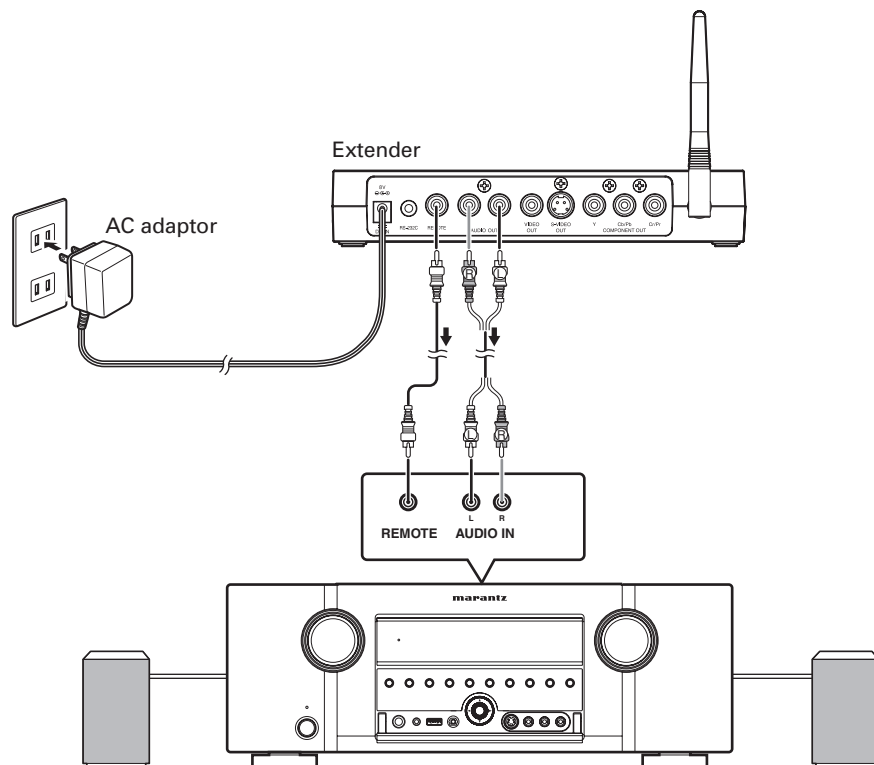

3. Attach the supplied antenna to the antenna terminal of the extender.
4. Connect the supplied AC adaptor to the AC adaptor terminal of the extender. (For details, see "PREPARATION OF THE AC ADAPTOR".)

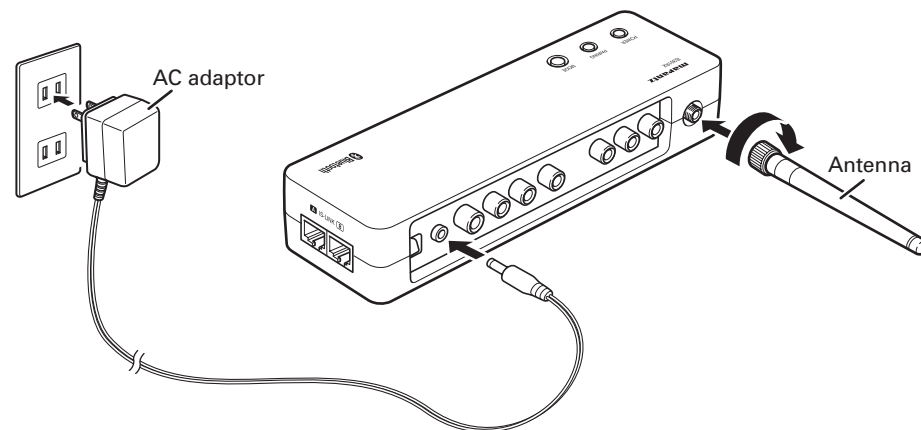

**PREPARATION OF THE AC ADAPTOR**

**POWER PLUG ATTACHMENT PROCEDURES**

1. Attach the supplied power plug to the supplied AC adaptor, by sliding the plug in the direction of the arrow.

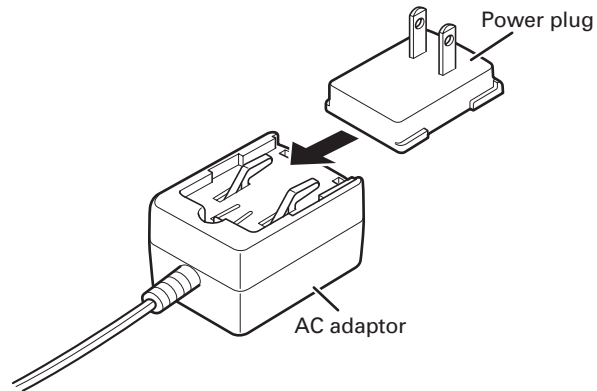

● For the U.K.

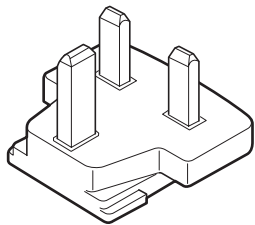

● For Europe

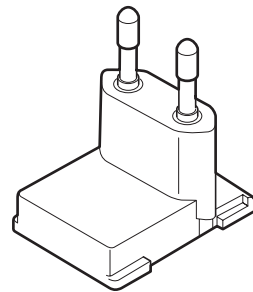

● For the U.S.A./Japan

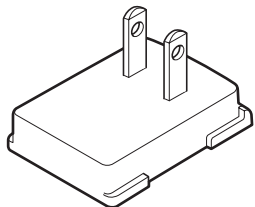

● For Australia

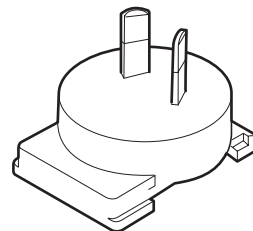

**Notes**

- NEVER use the power plug with equipment other than the supplied AC adaptor.
- Connect the AC adaptor to the wall outlet nearest its installation position.
- Before plugging/unplugging the cable of the AC adaptor to/from the AC input terminal, make sure that the power cord is unplugged from the wall outlet.
- If an improper power plug is attached to the AC adaptor, detach it by pressing the release button with a pointed object, such as a pen, as shown in the figure below.

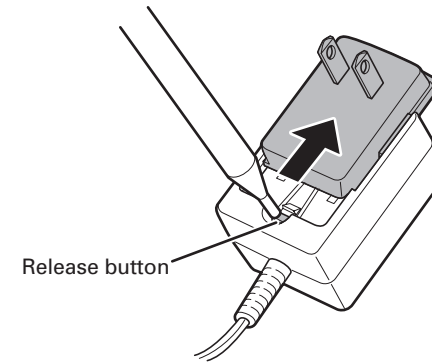

**ON POWER SUPPLY TO THIS UNIT**

A power switch is not provided for this unit. After connecting the AC adaptor to this unit, when the AC adaptor is plugged into a wall outlet, power is supplied to this unit.

## BASIC OPERATIONS

### ② CONNECTING THE HANDSET TO THE BASE UNIT

1. Attach the handset to the base unit, as shown in the figure below.

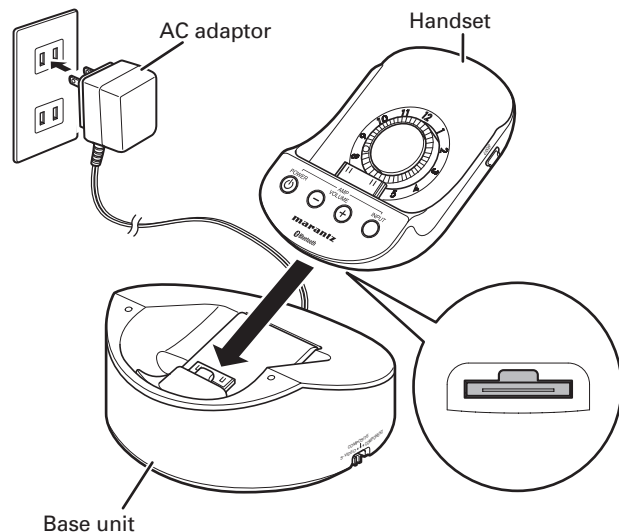

2. Connect the supplied AC adaptor to the AC adaptor terminal of the handset. (For details, see "PREPARATION OF THE AC ADAPTOR".)

### ③ CONNECTING iPod TO THE HANDSET

1. Turn the Thickness adjustment knob of the handset, according to the type of your iPod. For details on the positions of the knob, see the "LIST OF THICKNESS ADJUSTMENT KNOB POSITIONS" table.

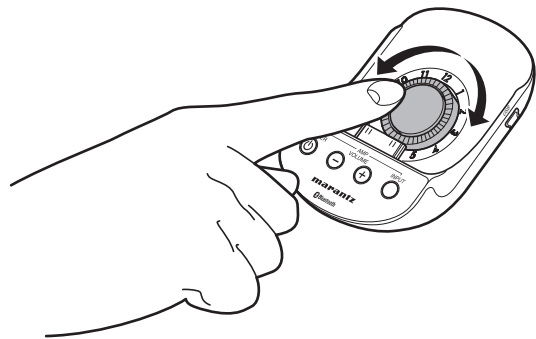

### LIST OF THICKNESS ADJUSTMENT KNOB POSITIONS

iPod	Positions of the knob
iPod touch 1G/2G	3
iPod classic 160GB	9
iPod classic 80GB/120GB	4
iPod 5G Video 60GB/80GB	9
iPod 5G Video 30GB	4
iPod 4G Photo 20GB/30GB	7
iPod 4G Photo 40GB/60GB	12
iPod 4G 20GB	6
iPod 4G 40GB	11
iPod nano 1G/2G/3G/4G	1
iPod mini	7

**G** in the table stands for Generation of iPod products.  
**Example: iPod 5G**  
 (iPod, Fifth generation)

#### Notes

- The location of the docking connector on an iPod product varies, according to the generation, type, and capacity of products.

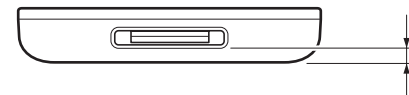

- Before attaching an iPod, be sure to turn the Thickness adjustment knob to an appropriate position. If an iPod is plugged/unplugged without adjusting the thickness to an appropriate position, damage to the connectors may result.

2. Securely connect the iPod to the docking connector of the handset.

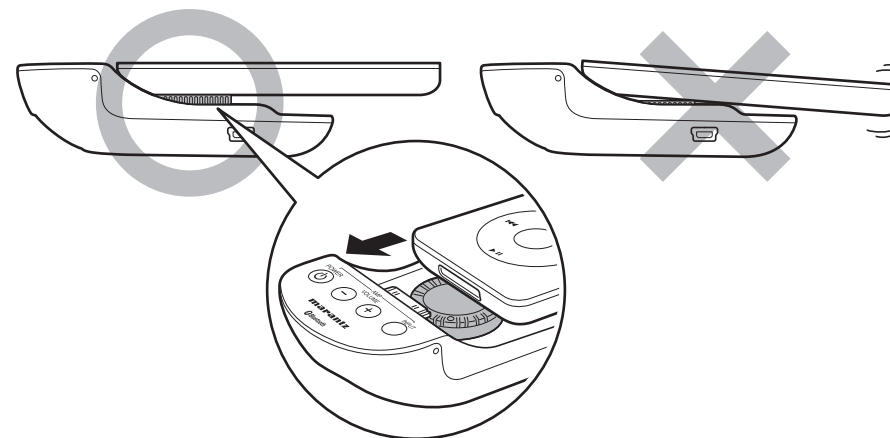

**Notes**

- When attaching/detaching the iPod to/from the handset, be sure to grip the handset by hand. Improper attaching/detaching of the iPod may damage the connectors.
- When attaching/detaching the iPod to/from the handset, be sure NOT to twist the iPod, as this may damage the connectors.
- Be careful NOT to tilt the iPod forward during use, as this may damage the connectors.

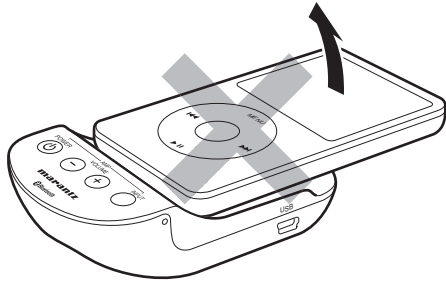

- NEVER insert the iPod into the handset with its protective case attached. Doing so may result in poor connection or damage to the connectors.
- Do not use other accessories, such as an FM transmitter or microphone, with the handset. This may result in a malfunction.
- Marantz accepts no responsibility whatsoever for any loss or damage of iPod data resulting from the use of an iPod product connected with this unit.

**④ WIRELESS CONNECTION OF THE HANDSET AND EXTENDER**

For wireless connection between the handset and extender, pairing is required for mutual authentication and registration. Perform pairing, according to the procedures shown below.

**PAIRING PROCEDURES**

1. Attach the handset to the base unit.
2. Locate the extender near the base unit and connect the AC adaptors to each of them.
3. Press and release the **PAIRING** button of the handset and the **MODE** button of the extender once. The **PAIRING** indicator will light in red (connection not established).

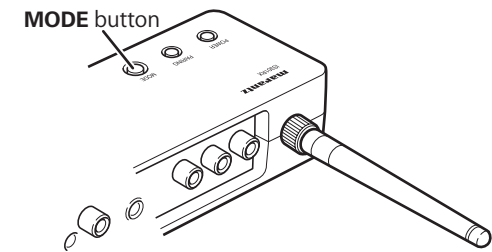

4. Hold the **PAIRING** button of the handset and the **MODE** button of the extender pressed for 5 seconds or more until the **PAIRING** indicator starts flashing in magenta at intervals of 0.5 second. The handset and extender will search for each other's pairing device.
5. After searching and pairing are completed, the color of the flashing **PAIRING** indicator at intervals of 0.5 second will change to blue. The unit will automatically start preparing for wireless audio playback.

When the **PAIRING** indicator starts flashing in blue at intervals of 5 seconds, preparation for audio playback is completed.

Play back the iPod.

**Notes**

- Even if wireless connection is interrupted for some reason, such as radio wave interference or power failure, reconnection will automatically be performed.
- If reconnection is not possible, the **PAIRING** indicator will light in red.

In such a case, press the **PAIRING** button of the handset twice to disconnect then press the same button again so that the **PAIRING** indicator lights in red.

Then press the **PAIRING** button once again. The **PAIRING** indicator will start flashing in blue at intervals of 0.5 second to start preparing for reconnection. When the **PAIRING** indicator starts flashing in blue at intervals of 5 seconds, preparation for reconnection is completed.

## BASIC OPERATIONS

### IS-LINK CONNECTIONS

#### WHAT IS AVAILABLE WHEN IS-LINK CONNECTIONS ARE MADE

- Audio and video playback
- Remote operations of a Marantz amplifier or receiver, using the **AMP control** buttons on the handset
- Remote control of a Marantz amplifier, using the supplied remote controller
- Use of the base unit as an infrared signal receiver for controlling a Marantz product

#### WHAT IS NOT AVAILABLE WHEN IS-LINK CONNECTIONS ARE MADE

- Audio/video playback of an iPod when the iPod and the handset are detached from the base unit

#### BEFORE CONNECTION

##### Notes

- If the handset is removed from the base unit during video playback, playback of iPod will automatically be stopped.
- During IS-LINK connection, power is supplied to the base unit from the extender. Therefore, it is not necessary to connect the AC adaptor to the base unit.
- Three types of video signals are output from the extender. Set the Video selection switch of the base unit according to the video output signal to be used.

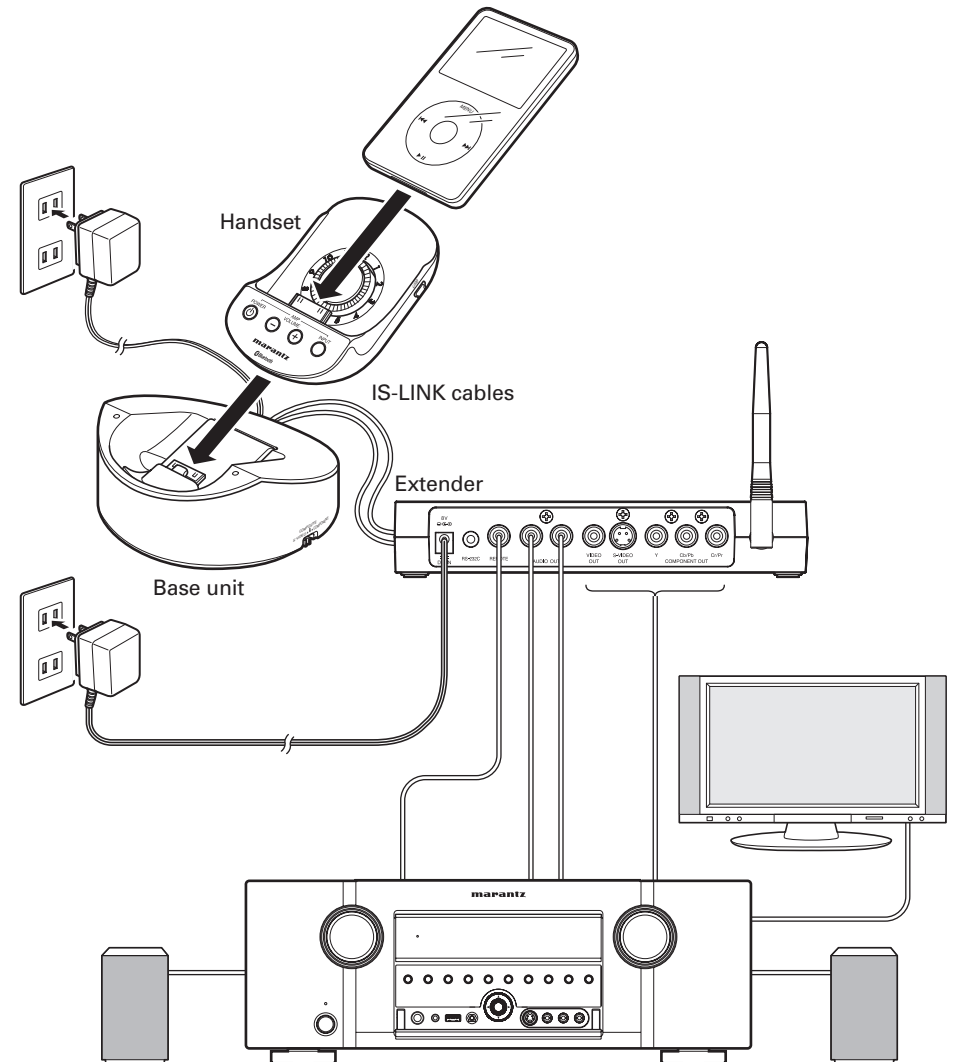
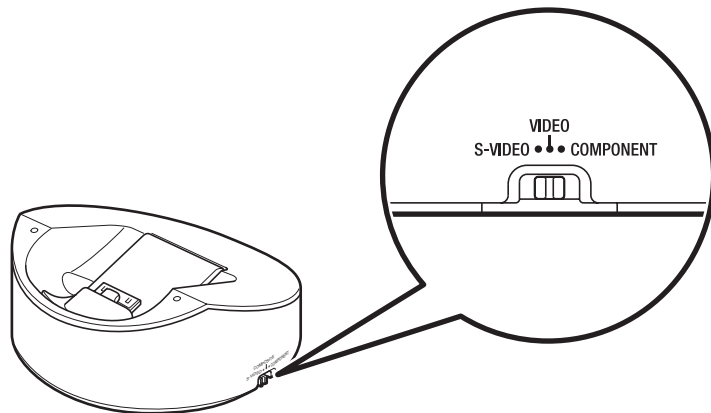

① CONNECTING THE EXTENDER AND AN AMPLIFIER

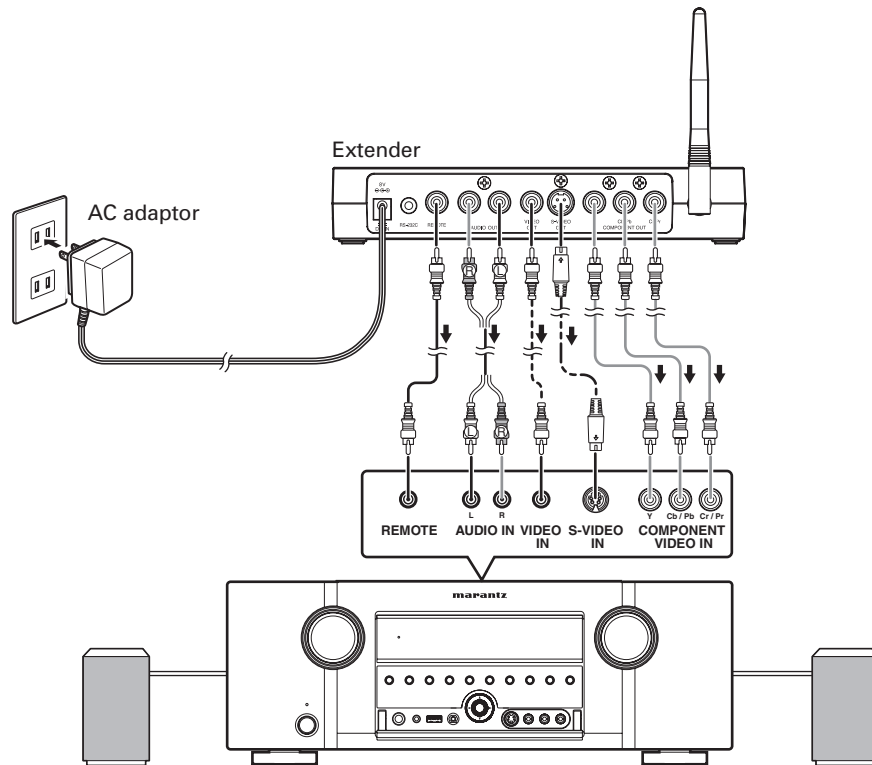

1. Connect the AUDIO OUT terminals of the extender with the line input terminals of an amplifier/receiver, via the supplied AV cable.
2. Connect the video input terminal of an amplifier/receiver/TV to one of the VIDEO OUT terminals (VIDEO/S-VIDEO/COMPONENT) of the extender, using an appropriate video cable.  
The S-VIDEO and component video cables are not supplied with this unit. Use a commercially available video cable.

**Note**

NEVER connect different video cables simultaneously, as this may result in disturbed video signals or a failure.

3. If you wish to remotely control the connected equipment using the Marantz REMOTE CONTROL terminals, connect the REMOTE terminals of the connected equipment and the extender with the supplied remote cable.

② CONNECTING THE BASE UNIT AND EXTENDER WITH IS-LINK

1. Connect the base unit and extender with two supplied IS-LINK cables.

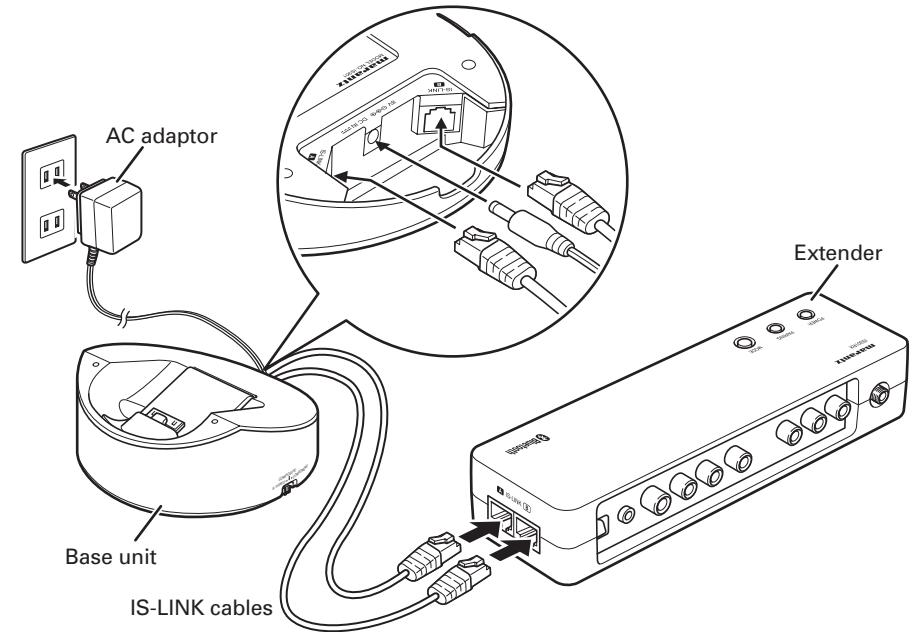

2. Connect the supplied AC adaptor to the AC adaptor terminal of the extender. (For details on preparation of the AC adaptor, see page 8.)

③ CONNECTING THE HANDSET TO THE BASE UNIT

For details on connection, see page 9.

④ CONNECTING AN iPod TO THE HANDSET

For details on connection, see page 10.



## ADVANCED OPERATIONS

### CONNECTING THE EXTENDER WITH OTHER BLUETOOTH DEVICES

The extender can be connected with other Bluetooth devices with the A2DP profile.

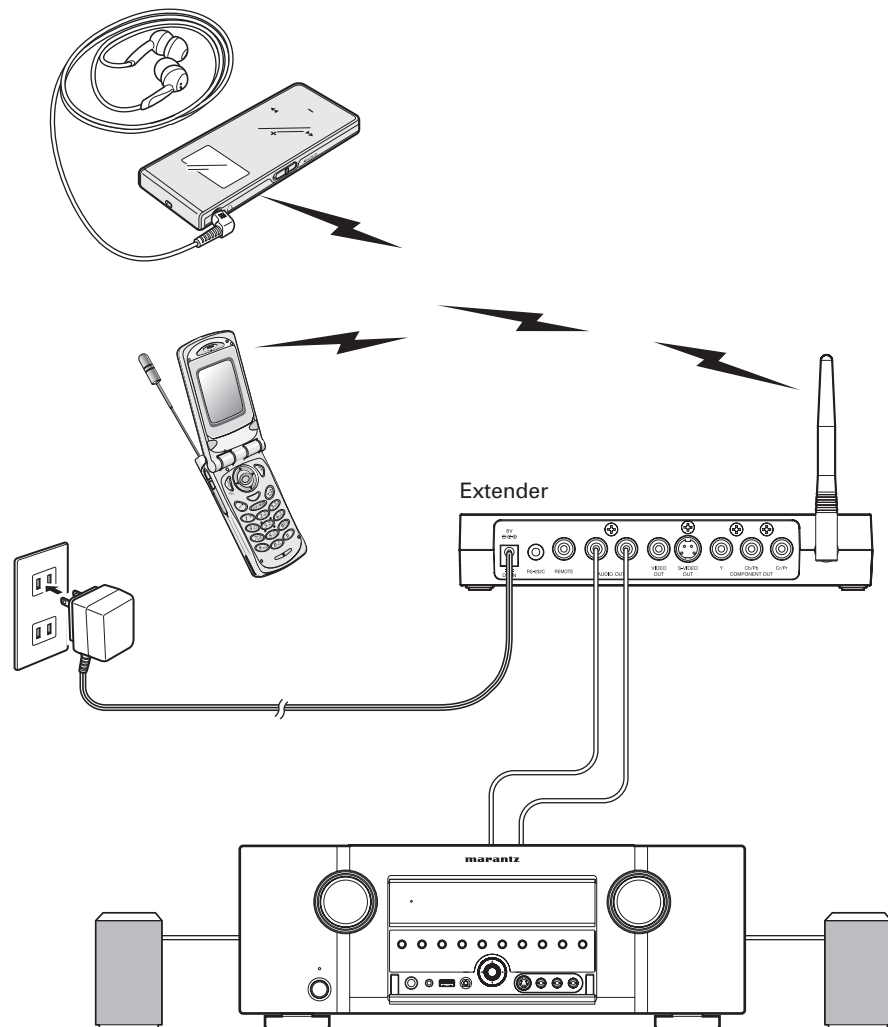

1. Press the **PAIRING** button of the handset. The PAIRING indicator will light in red, and wireless communication on the handset side will stop.

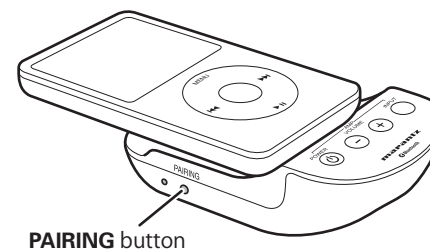

2. Locate other Bluetooth device near the extender.
3. Press the **MODE** button of the extender once. The PAIRING indicator will light in red. Refer to the operation manual of your Bluetooth device for pairing procedures of the connected Bluetooth device.

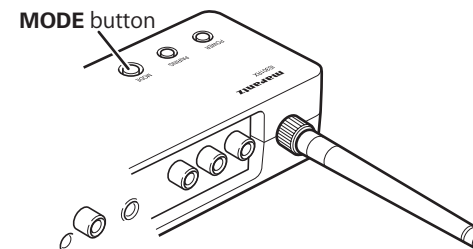

4. Hold the **MODE** button pressed for 5 seconds or more until the PAIRING indicator starts flashing in magenta at intervals of 0.5 second. The unit will search for a device for pairing.
5. After a device to be paired is found, the color of the flashing PAIRING indicator at intervals of 0.5 second will change to blue. The unit will automatically start preparing for wireless audio playback.  
If passcode input is requested on the other Bluetooth device, enter "0000".
6. After connection with the A2DP/AVRCP profiles is established, the PAIRING indicator starts flashing in blue at intervals of 5 seconds, and preparation for playback is completed.

**Notes**

- Once pairing is completed, further pairing operation is not required for the same devices from the next Bluetooth communication.
- Up to 8 Bluetooth devices that have A2DP/AVRCP profiles can be paired with this unit.
- If the number of paired devices exceeds 8, each time a new device is paired, the already paired devices are cleared from the oldest one.
- Connection of the handset with other Bluetooth devices is possible in the same way as with the handset.
- Bluetooth and its logo are trademarks of Bluetooth SIG, Inc. and Marantz uses them based on the appropriate license.
- Connection with all existing Bluetooth devices is not guaranteed.

**MOUNTING ON A WALL**

This unit can be mounted on a wall. Read the precautions described below and carefully install the unit. For safety, it is recommended to delegate mounting to a professional contractor.

**NOTES ON INSTALLATION LOCATION**

- Before installation, check the material and construction compatibilities of the installation location. If they are not assured, the unit may fall, which may result in personal injury.
- NEVER mount the unit in a location subject to lot of vibration, shock, or strong force. Doing so may cause a fall or damage of the unit and may result in personal injury.
- Before installation, make sure that there is no electrical wiring nor piping inside the wall.

**PRECAUTIONS ON INSTALLATION**

- NEVER modify the unit or use it in an inappropriate way. Dropping the unit may result in personal injury.
- Use commercially available screws that are suitable for the wall construction and materials.
- Secure the screws tightly when mounting the base unit. Loose screws may cause an accident, such as falling of the unit. NEVER leave the screws not securely tightened.
- NEVER mount the unit so that it will protrude away from an exterior corner of the wall. Doing so may lead to personal injury, because a person or object may bump into the unit.
- Marantz accepts no responsibility whatsoever for any accident or damage resulting from improper mounting or handling.
- When mounting, be careful not to pinch your fingers or hands.
- Make sure that the two screws are securely tightened in the holes for wall mounting of the extender.

## ADVANCED OPERATIONS

### INSTALLATION PROCEDURES FOR THE BASE UNIT

1. Remove the handset from the base unit.
2. Push the handset holder from through the hole on the bottom of the base unit.

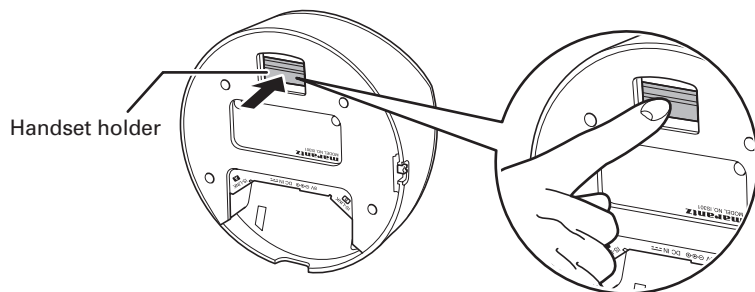

3. Move the stopper at the rear of the handset holder backward until it clicks and locks.

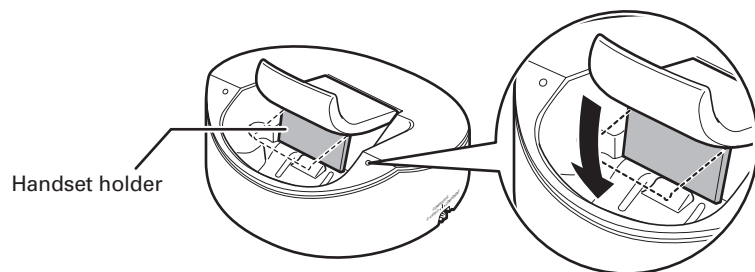

4. Connect the cables.

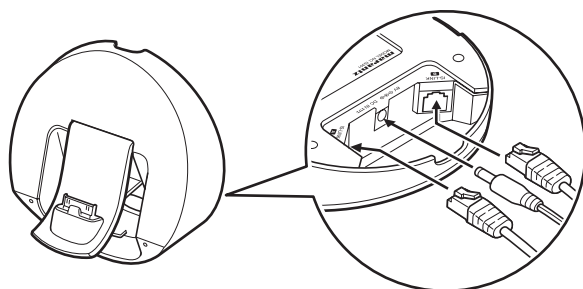

5. Secure the base unit on the wall, by tightening the screws of the size shown in the figure below, using a screwdriver, through the holes for wall mounting of the base unit.

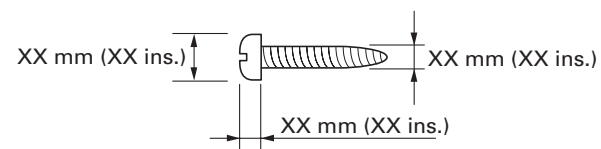
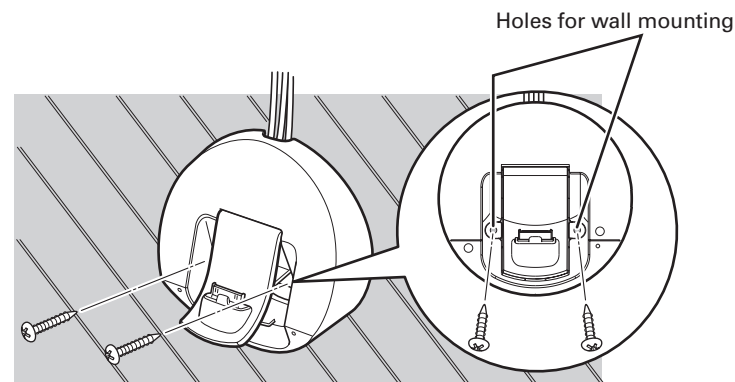

#### Notes

- Check that the unit is securely fixed on the wall.
- Securely connect the cables to the unit.
- To detach the unit from the wall and use it on a table, return the stopper to its original position, by holding the release button pressed, then return the handset holder to its original position.

**INSTALLATION PROCEDURES FOR THE EXTENDER**

The extender can be mounted on a wall or a rack, using the two holes provided on the bottom of the extender.

The extender can be installed in either a horizontal or vertical orientation. Select the orientation according to the installation conditions.

**Notes**

- Reception sensitivity varies, depending on the direction of the antenna. Before installing the extender, adjust the orientation of the antenna and check that radio waves can be securely received.
- Screws for wall mounting are not provided. @@@@PEND@@@@
- Before mounting on a wall, read the precautions thoroughly.

1. Procure two screws that are suitable for the strength and material of the wall surface. The size of the screws is shown in the figure below.

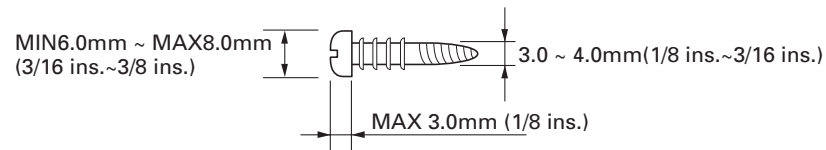

2. The relative positions of the holes for wall mounting of the extender and screw-mounting positions are shown in the figure below. (Use the template provided on the last page of this manual.)

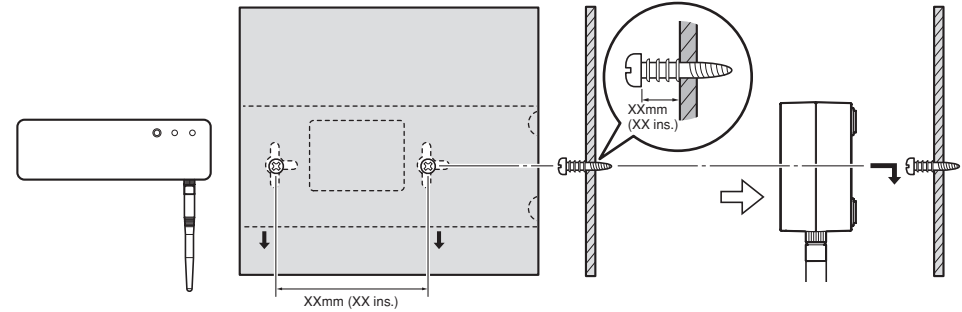
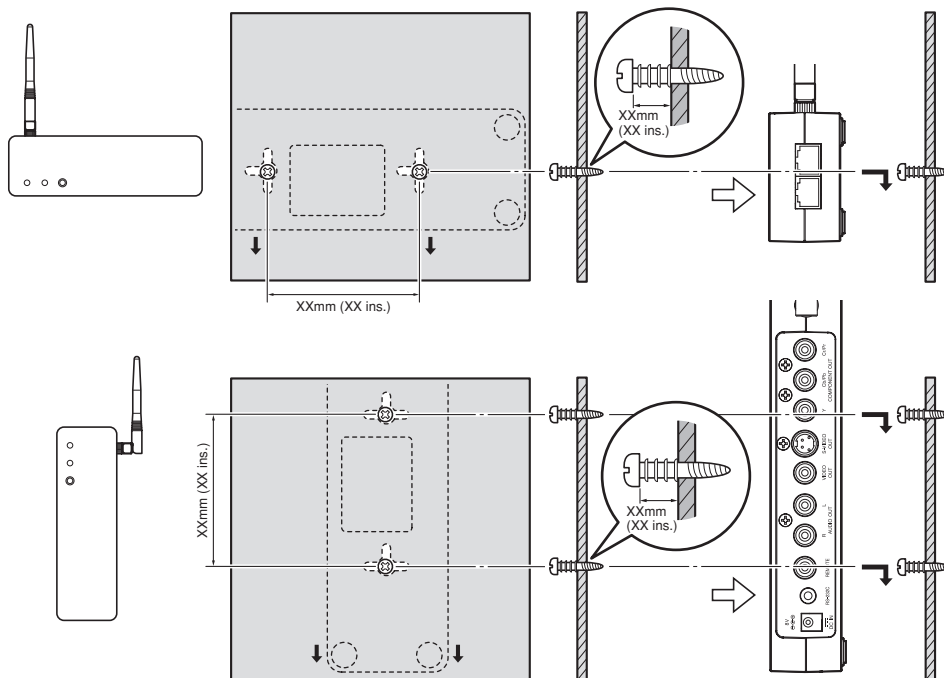

**Note**

When tightening the screws in the wall surface, leave a gap between the wall surface and the head of the screw, as shown in the figure.

3. Place the extender so that the two screws in the wall are inserted through the holes for wall mounting of the extender, then slide the extender downward to secure it on the wall.
4. After securing the extender on the wall, connect the AC adaptor and other cables.

**Notes**

- Check that the extender is securely fixed to the wall.
- Securely connect the AC adaptor and cables to the extender.

5. To detach the extender from the wall, lift it upward then pull out toward you.

## ADVANCED OPERATIONS

### USE OF THE REMOTE CONTROLLER (RC001IS)

#### BEFORE USING THE REMOTE CONTROLLER

A lithium battery comes installed in the remote controller. Before use, pull out the insulation sheet.

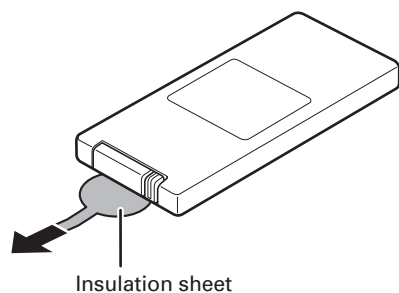

#### BATTERY REPLACEMENT

If the battery of the remote controller is exhausted, the operable distance of the remote controller becomes extremely short. In such a case, replace the battery with a new one.

1. Pull out the battery case, referring to the figures depicted on the rear panel of the remote controller.
2. Pull out the old lithium battery from the battery case and insert a new one. Place the battery so that the + (positive) side faces upward.
3. Replace the battery case in its original position.

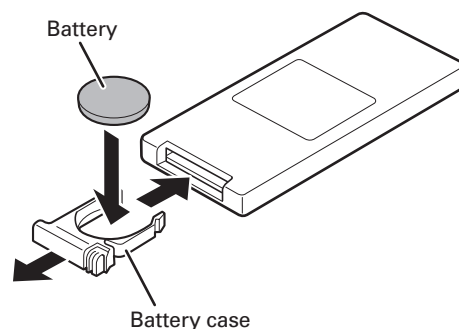

#### OPERABLE RANGE OF THE REMOTE CONTROLLER

The operable range of the remote controller is shown in the figure below.

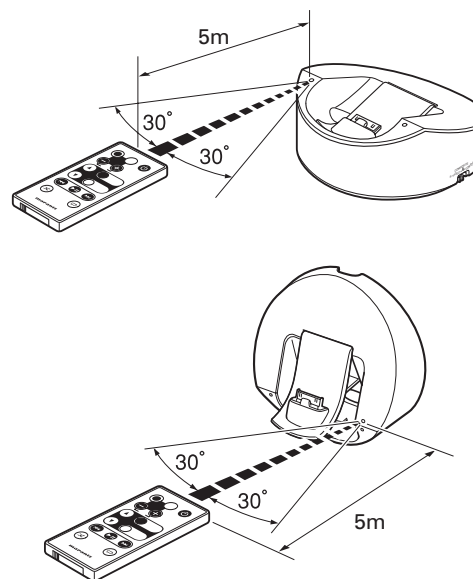

#### Notes On Use

- Do not allow direct sunlight, an inverter fluorescent light or other strong light to shine onto the unit's infrared signal reception window (remote sensor). Doing so may disable operation of the remote controller.
- Note that operating the remote controller may cause other devices operated by infrared rays to be operated by mistake.
- The remote controller cannot be operated if the line of sight between the remote controller and the unit's remote sensor is obstructed.
- Do not place any objects on top of the remote controller. Doing so may cause one or more buttons to be held down, which will cause the battery to run down.

#### CAUTIONS ON HANDLING BATTERIES

Misuse of the lithium battery can result in heat buildup, ignition, or rupture. Bear in mind the following points when using or replacing batteries.

- The supplied battery is for testing the functionality of the remote controller.
- Use a CR2032 lithium battery.
- NEVER recharge the battery.
- Do not handle the battery roughly or deconstruct the battery.
- When replacing the battery, place it with correct polarity (+ and -).
- Do not leave the battery in a place subject to high temperature, such as a place subject to direct sunlight.
- Keep the battery in a place beyond infants' or children's reach. If a battery is swallowed, consult a physician immediately.
- If electrolyte has leaked, discard the battery immediately. Be careful when handling such a battery, because if the electrolyte is attached to your skin or clothes, you may be burned. If it is accidentally attached, immediately wash with tap water then consult a physician.
- When a battery which is no longer required is to be discarded, insulate it with tape, etc. and dispose of it in a place without fire, by following the directions (regulations) laid down by the local authorities in the area concerned for its disposal.

## NAMES AND FUNCTIONS OF THE REMOTE CONTROLLER

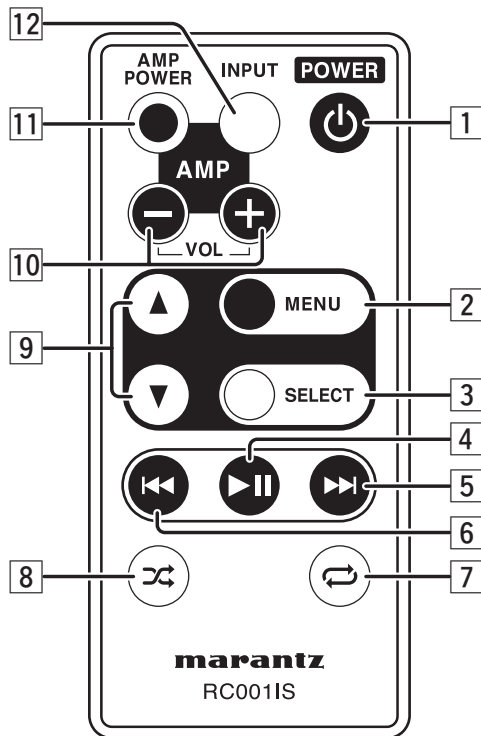

### 1 POWER button

Used to turn the power to the iPod on or off.

### 2 MENU button

This button operates in the same way as the MENU button on the iPod.

### 3 SELECT button

This button operates in the same way as the Select button on the iPod.

### 4 ►|| (Playback/pause) button

This button operates in the same way as the ►|| button on the iPod.

### 5 ►► (Skip) button

Press this button once to skip to the next content.

### 6 ◀◀ (Back skip) button

Press this button once to return to the beginning of the content being played back.  
Press this button twice consecutively to return to the previous content.

### 7 Repeat button

Used to change the Repeat mode of the iPod.  
(One song → All songs → Off)

### 8 Shuffle button

Used to change the Shuffle mode of the iPod.  
(Songs → Albums → Off)

### 9 ▲▼ buttons

These buttons operate in the same way as the Up (▲) and Down (▼) buttons on the iPod.  
These buttons are also used to move the cursor.  
(Volume adjustment of the iPod is excluded.)

### 10 AMP VOL +/- buttons

Used to increase/decrease the volume of a Marantz amplifier/receiver remotely connected with this unit.

### 11 AMP POWER button

Used to turn ON/OFF a Marantz amplifier/receiver remotely connected with this unit.

### 12 AMP INPUT button

Used to switch the input sources of a Marantz amplifier/receiver remotely connected with this unit. (Some models cannot be remotely controlled with this button.)

#### Note

Operations of the remote controller may differ, depending on the generation and model of the iPod products.



## TROUBLESHOOTING

Be sure to check the items in the following list if you experience problems. If checking the following items does not resolve your problem, please contact the retail store where you purchased your product or your nearest Marantz Consumer Marketing or Service Center.

Symptom	Possible cause	Resolution
<b>No sound or video</b>	The iPod is not properly connected with the iPod docking connector of this unit.	Disconnect the iPod from the docking connector then connect it again.
	No playback from the iPod	Play back the iPod.
	The cables connected to this unit are not fully plugged in.	Check the cable connections.
	The AC adaptor is not securely connected to this unit or is unplugged from the wall outlet.	Securely connect the AC adaptor to the unit and plug it into the wall outlet.
<b>No sound</b>	Pairing for Bluetooth communication has not been properly completed.	Perform pairing for Bluetooth (wireless) communication again.
	The receiver or amplifier connected to this unit is not turned on.	Turn the receiver or amplifier on.
	The input terminal on the receiver or amplifier to which the output signal from the iPod is fed is not properly selected.	Check the input of the receiver or amplifier.
	The volume of the receiver or amplifier to which this unit is connected is very low.	Increase the volume of the receiver or amplifier.
<b>No image</b>	Wireless connection is used.	IS-LINK connections are required.
	The video output setting of the iPod is not proper.	Check the video output setting of the iPod.
	The setting of the Video selection switch on the base unit is inappropriate.	Set the Video selection switch, according to the video output terminal to which the video cable is connected.
<b>Distorted sound</b>	There is a device, such as a wireless LAN or microwave, that uses radio waves in the same frequency band (2.4-GHz) as this unit.	Change the locations of the handset and extender.
<b>No operation with the supplied remote controller</b>	The iPod is not properly connected with the iPod docking connector of this unit.	Disconnect the iPod from the docking connector then connect it again.
	There is an object that interrupts infrared signals between the unit and the remote controller.	Remove any object between the unit and the remote controller.
	The remote control cable is not properly connected.	Check the cable connections.

## OTHERS

### CLEANING OF EQUIPMENT EXTERNAL SURFACES

The exterior finish of your unit will last indefinitely with proper care and cleaning. Never use scouring pads, steel wool, scouring powders or harsh chemical agents (e.g., lye solution), alcohol, thinner, benzene, insecticide or other volatile substances as these will mar the finish of the equipment. Likewise, never use cloths containing chemical substances. If the equipment gets dirty, wipe the external surfaces with a soft, lint-free cloth.

If the equipment becomes heavily soiled:

- dilute some washing up liquid in water, in a ratio of one part detergent to six parts water.
- dip a soft, lint free in the solution and wring the it is damp.
- wipe the equipment with the damp cloth.
- dry the equipment by wiping it with a dry cloth.



### REPAIRS

Only the most competent and qualified service technicians should be allowed to service the factory-trained warranty station personnel have the knowledge and special facilities needed for repair and calibration of this precision equipment.

After the warranty period has expired, repairs will be performed for a charge if the equipment can be returned to normal operation.

In the event of difficulty, refer to your dealer or write directly to the nearest location to you that is listed on the Marantz Authorized Service Station list. If writing, please include the model and serial number of the equipment together with a full description of what you think is abnormal about the equipment's behaviour.

## SPECIFICATIONS

### IS301 (HANDSET)

Power supply .....3.3 V DC from iPod accessory power supply  
 Weight ..... @ g  
 External dimensions (W/H/D)..... @ x @ x @ mm  
 Terminals..... USB mini B

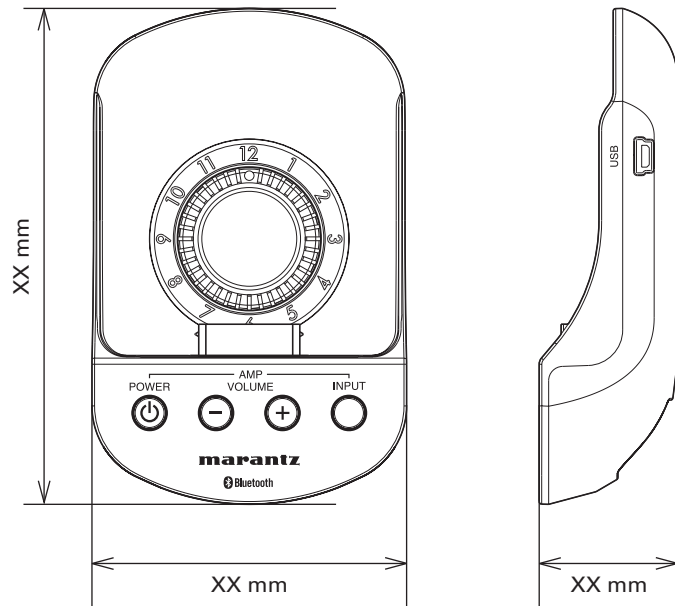

### IS301DS (BASE UNIT)

Power supply .....8 V DC IN (from the dedicated AC adaptor)  
 Weight ..... @ g  
 External dimensions (W/H/D)..... 120 x 120 x @ mm  
 Terminals..... RJ-45 x2

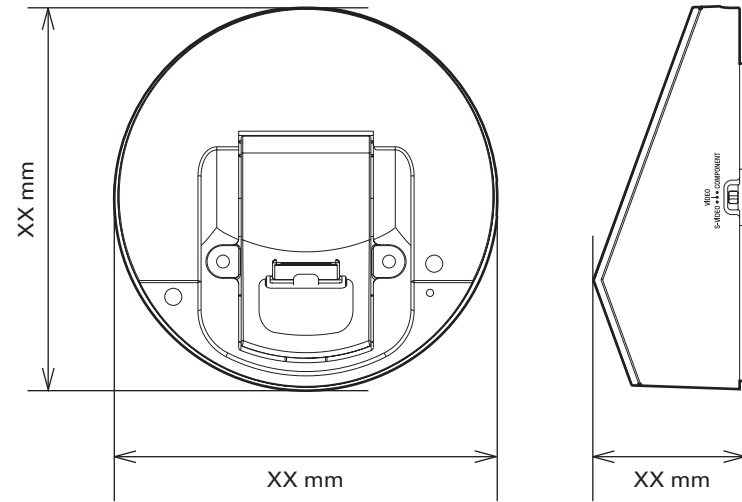

OTHERS

**S301RX (EXTENDER)**

Power supply ..... 8 V DC IN (from the dedicated AC adaptor)  
 Weight ..... @ g  
 External dimensions (W/H/D)..... @ x@ x@ mm  
 Terminals..... Video output (S-VIDEO x1, VIDEO x1, COMPONENT x1)  
 ..... Analog audio x1, Remote terminal x1, RS-232C terminal x1, RJ-45 x2

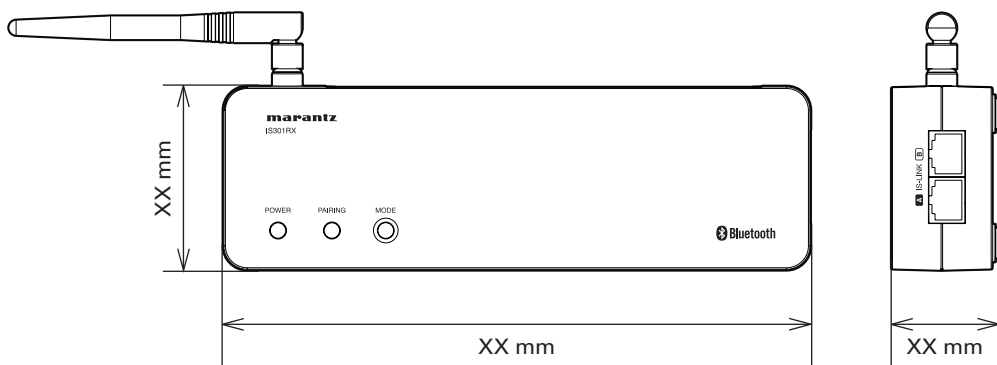

**BLUETOOTH-RELATED (IS301/IS301RX)**

Communication method ..... Bluetooth ver. 2.1 + EDR  
 Transmission output..... Bluetooth Power Class 2  
 Maximum transmission distance ..... Line-of-sight distance approx. 10 m(\*1)  
 Transmission frequency band ..... 2.400 GHz to 2.4835 GHz  
 Modulation method..... FH-SS  
 Supporting Bluetooth profiles ..... A2DP (Advanced Audio Distribution Profile),  
 AVRCP (Audio Video Remote Control Profile)  
 Supporting CODEC ..... SBC (Subband Codec)  
 Supporting content protection ..... SCMS-T (Only for the IS301RX)  
 Passcode..... 0000

(\*1) The transmission distance is an approximate value. It may vary, depending on the ambient environment.

- Bluetooth and its logo are trademarks of Bluetooth SIG, Inc. and Marantz uses them based on an appropriate license.
- Connection with all existing Bluetooth devices is not guaranteed.

**SUPPLIED AC ADAPTOR**

Power supply ..... 100 V - 240 V AC (50 Hz/60 Hz) 1A

**The specifications and external appearance of this unit may be changed without prior notification for the purpose of improvement.**

**www.marantz.com**

You can find your nearest authorized distributor or dealer on our website.

**marantz**<sup>®</sup> is a registered trademark.

