



Bluetooth Docking Music System with Rotating Lightning™ Dock for iPhone® and iPod®



JiLS-525iB
USER MANUAL
(iPod/iPhone Not Included)

PLEASE READ THIS USER MANUAL COMPLETELY BEFORE OPERATING THIS UNIT AND RETAIN THIS BOOKLET FOR FUTURE REFERENCE.

DEAR JENSEN® CUSTOMER

Selecting fine audio equipment such as the unit you've just purchased is only the start of your musical enjoyment. Now it's time to consider how you can maximize the fun and excitement your equipment offers. This manufacturer and the Electronic Industries Association's Consumer Electronics Group want you to get the most out of your equipment by playing it at a safe level. One that lets the sound come through loud and clear without annoying blaring or distortion and, most importantly, without affecting your sensitive hearing. Sound can be deceiving. Over time your hearing "comfort level" adapts to higher volumes of sound. So what sounds "normal" can actually be loud and harmful to your hearing. Guard against this by setting your equipment at a safe level BEFORE your hearing adapts.

To establish a safe level:

- Start your volume control at a low setting.
- Slowly increase the sound until you can hear it comfortably and clearly, and without distortion.

We Want You Listening For a Lifetime

Used wisely, your new sound equipment will provide a lifetime of fun and enjoyment. Since hearing damage from loud noise is often undetectable until it is too late, this manufacturer and the Electronic Industries Association's Consumer Electronics Group recommend you avoid prolonged exposure to excessive noise.



Customer's Record:

The serial number of this product is found on its bottom. You should note the serial number of this unit in the space provided as a permanent record of your purchase to aid in identification in the event of theft or loss.

Model Number: JiLS-525iB

Serial Number: _____

IMPORTANT SAFETY INSTRUCTIONS

When used in the directed manner, this unit has been designed and manufactured to ensure your personal safety. However, improper use can result in potential electrical shock or fire hazards. Please read all safety and operating instructions carefully before installation and use, and keep these instructions handy for future reference. Take special note of all warnings listed in these instructions and on the unit.

1. Read these instructions – All the safety and operating instructions should be read before the appliance is operated.
2. Keep these instructions – The safety and operating instructions should be kept for future reference.
3. Heed all warnings – All warnings on the appliance and in the operating instructions should be adhered to.
4. Follow all instructions – All operation and use instructions should be followed.
5. Do not use this apparatus near water – The appliance should not be used near water; for example, near a bath tub, washbowl, kitchen sink, laundry tub, in a wet basement, or near a swimming pool.
6. Clean only with dry cloth – The appliance should be cleaned only as recommended by the manufacturer.
7. Do not block any ventilation openings. Install in accordance with the manufacturer's instructions. The appliance should be situated so that its location or position does not interfere with its proper ventilation. For example, the appliance should not be situated on a bed, sofa, rug, or similar surface that may block the ventilation openings; or placed in a built-in installation, such as a bookcase or cabinet that may impede the flow of air through the ventilation openings.
8. Do not install near any heat sources such as radiators, heat registers, stoves, or other apparatus (including amplifiers) that produce heat.
9. Protect the power cord from being walked on or pinched particularly at plugs, convenience receptacles, and the point where they exit from the apparatus.
10. Only use attachments / accessories specified by the manufacturer.
11. Unplug this apparatus during lightning storms or when unused for long periods of time.
12. Refer all servicing to qualified service personnel. Servicing is required when the apparatus has been damaged in any way, such as power-supply cord or plug is damaged, liquid has been spilled or objects have fallen into the apparatus, the apparatus has been exposed to rain or moisture, does not operate normally, or has been dropped.
13. This appliance shall not be exposed to dripping or splashing water and that no object filled with liquids such as vases shall be placed on the apparatus.
14. Power Sources – The appliance should be connected to a power supply only of the type described in the operating instructions or as marked on the appliance. Do not overload wall outlet.
15. Danger of explosion if battery is incorrectly replaced. Replace only with the same or equivalent type.
16. Do not attempt to dismantle, open or repair this product yourself. If a fault occurs, seek advice from your local qualified service technician or contact the distributor via the telephone number at the back of this instruction manual.
17. Caution marking and nameplate are located at the rear of product.

COMPLIANCE WITH FCC REGULATIONS

This device complies with Part 15 of the FCC Rules. Operation is subject to the following two conditions:

- (1) this device may not cause harmful interference, and
- (2) this device must accept any interference received, including interference that may cause undesired operation.

NOTE : This equipment has been tested and found to comply with the limits for a Class B digital device, pursuant to Part 15 of the FCC Rules. These limits are designed to provide reasonable protection against harmful interference in a residential installation. This equipment generates, uses and can radiate radio frequency energy and, if not installed and used in accordance with the instructions, may cause harmful interference to radio communications. However, there is no guarantee that interference will not occur in a particular installation. If this equipment does cause harmful interference to radio or television reception, which can be determined by turning the equipment off and on, the user is encouraged to try to correct the interference by one or more of the following measures:

- Reorient or relocate the receiving antenna.
- Increase the separation between the equipment and receiver.
- Connect the equipment into an outlet on a circuit different from that to which the receiver is connected.
- Consult the dealer or an experienced radio/TV technician for help.

CAUTION: Changes or modifications not expressly approved by the party responsible for compliance could void the user's authority to operate the equipment.

PROTECT YOUR FURNITURE

This model is equipped with non-skid rubber 'feet' to prevent the product from moving when you operate the controls. These 'feet' are made from non-migrating rubber material specially formulated to avoid leaving any marks or stains on your furniture. However certain types of oil based furniture polishes, wood preservatives, or cleaning sprays may cause the rubber 'feet' to soften, and leave marks or a rubber residue on the furniture. To prevent any damage to your furniture we strongly recommend that you purchase small self-adhesive felt pads, available at hardware stores and home improvement centers everywhere, and apply these pads to the bottom of the rubber 'feet' before you place the product on fine wooden furniture.

PRECAUTIONS AND IMPORTANT NOTES

PRECAUTIONS

- Do not connect the AC Adaptor to the unit and mains before checking the mains voltage.
- Do not cover any vents and make sure that there is a space of several inches around the unit for ventilation.
- This unit is not magnetically shielded and may cause color distortion on the screen of some TVs or video monitors. To avoid this, you may need to move the unit further away from the TV or monitor if abnormal color shifts or image distortion occurs.



IMPORTANT NOTES

- For best iPhone/iPod display clarity, avoid operating the unit in direct sunlight or under bright lights.
- Avoid installing the unit in locations described below:
- Places exposed to direct sunlight or close to heat radiating appliances such as electric heaters.
 - Places subject to constant vibration.
 - Dusty, humid or moist places.
 - Sources of electrical noise such as fluorescent lamps or motors.

LOCATION OF CONTROLS

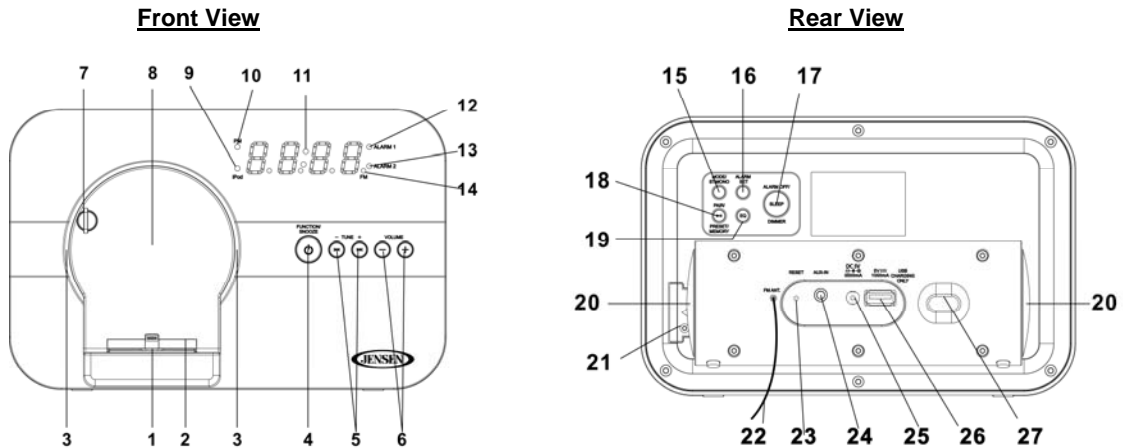
Main Unit





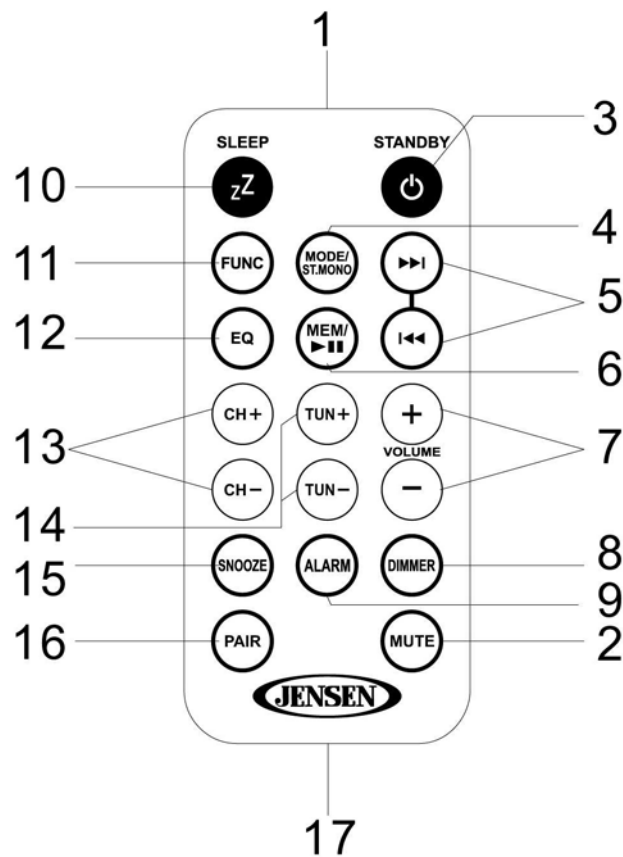

CONTROL		FUNCTION DESCRIPTION
1	Lightning Connector	
2	Docking Platform	
3	Power Indicator	LED indicator lights when the power is ON.
4	 / FUNCTION / SNOOZE Button	<ul style="list-style-type: none"> - Tap to turn unit on. - Press and hold to return unit to standby mode. - While unit is on, tap to select Radio , iPod , Bluetooth and AUX-IN mode. - Activates the snooze function.
5	TUNE + / -  button	<ul style="list-style-type: none"> - In radio mode: Tune the radio frequency up/down; select preset station channel. - In iPod/Bluetooth mode: Skip tracks Forward / Backward; fast-forwarding / fast-rewinding during playback.
6	VOLUME + / - Button	Adjust the speaker volume level.
7	Removable Support Tab	Support for the iPod/iPhone when in landscape mode.
8	Support Assembly	Allows the back of your Apple device to rest securely in place.
9	iPod LED Indicator	LED indicator lights when in iPod/iPhone mode.
10	PM LED Indicator	12 hour time format only: LED indicator is ON when time shown is PM and is OFF when time is AM.
11	LED Display	
12	ALARM 1 LED Indicator	LED indicator lights when Alarm 1 is ON.
13	ALARM 2 LED Indicator	LED indicator lights when Alarm 2 is ON.
14	FM Radio Mode LED Indicator	LED indicator lights when in FM Radio mode.
15	MODE / FM ST/MO Button	<ul style="list-style-type: none"> - Set clock and 12/24 hour format. - Select between STEREO or MONO FM radio receiving modes.
16	ALARM SET Button	- Set alarm time and select alarm source.
17	ALARM OFF / SLEEP / DIMMER Button	<ul style="list-style-type: none"> - Turn the alarm OFF. - Select the time duration of the sleep timer. - Adjust the LED display bright/dim.
18	PRESET/PLAY/PAUSE  PAIR/MEMORY Button	<ul style="list-style-type: none"> - Enter Radio preset mode. - iPhone/iPod/Bluetooth music Play/Pause function. - Bluetooth Pairing Function - In Radio mode: Save preset radio station.
19	EQ Button	<ul style="list-style-type: none"> - Tap to select a preset EQ setting. - Press and hold to enter Treble / Bass setting mode.
20	Speakers	

21	Clock / Memory backup battery compartment	
22	FM Antenna Wire	
23	RESET Button	Press this to return the unit to normal status in case it exhibits abnormality during operation.
24	AUX-IN Jack	Connect any compatible portable audio device to this jack for amplified audio output.
25	DC Jack	Only connect the supplied AC-DC Power Adaptor to this jack to power the unit.
26	USB Charging Connector	DC 5V (1000mA) power output source for charging a separate smart phone.
27	Bass Reflex Opening	This opening should never be blocked otherwise the bass effect will be reduced.

Remote Control



CONTROL		FUNCTION DESCRIPTION
1	Infrared Transmitter	Sends control signals to the main unit; do not block.
2	MUTE Button	Mute the volume.
3	STANDBY  Button	Turn the unit on and off.
4	MODE / FM ST/MO Button	Set clock and 12/24 hour format; select FM radio stereo/mono receiving mode.
5	 /  Button	In iPod/Bluetooth mode: Skip tracks Forward / Backward; fast-forwarding / fast-rewinding during playback
6	MEM /  Button	- In radio mode: Save preset radio station. - iPhone/iPod music Play/Pause function.
7	VOLUME + / - Button	Adjust the speaker volume level.

8	DIMMER Button	Turn LED display bright/dim.
9	ALARM Button	- At Standby mode: Enter alarm setting mode; - Turn the alarm on/off.
10	SLEEP zZ Button	Select the time duration of the sleep timer.
11	FUNCTION Button	While unit is on, tap to select iPod, Radio, Bluetooth and AUX-IN mode.
12	EQ Button	Select preset EQ; enter Treble / Bass setting mode.
13	CH + / - Button	In radio mode: Select preset station channel.
14	TUN + / - Button	In radio mode: Tune the radio frequency up/down.
15	SNOOZE Button	Activate the snooze function.
16	PAIR Button	Enter Bluetooth pairing mode
17	Battery Compartment	

GETTING STARTED

POWER SUPPLY SOURCES

This Bluetooth Docking Music System operates using the included AC Adaptor with 5V $\overline{=}$ 3500 mA (center-positive) output and is compatible with standard 120V~ 60Hz AC household power. This unit also requires 1 x CR2032 Lithium battery (included) for clock backup during power outage.

CONNECTING THE UNIT TO THE AC ADAPTOR POWER

Plug the AC Adaptor into the DC Jack on the back of unit. Plug the adaptor into a standard 120V~ 60Hz AC outlet.

Note: Do not use a different AC adaptor other than the one included. Your Apple device may fail to charge and you could damage the dock and/or the Apple device that is docked. A fire hazard can also occur due to system overloading.

CLOCK SETTING / MEMORY BATTERY BACK-UP

A backup battery compartment is located at rear of the unit.

- (1) Loosen the battery compartment screw.
- (2) Open the battery compartment lid.
- (3) For the first time use: just remove the insulation tag.
For battery replacement: install a DC 3V CR2032 type Lithium battery (with the polarity plus side facing up).
- (4) Close the battery compartment lid.
- (5) Screw tight the compartment lid.

REMOTE CONTROL

The remote control works on one 3V $\overline{=}$ type CR2025 lithium battery (Included).

Remove the insulation tab from the battery compartment to activate the remote before first use.

When the operation of the remote control becomes intermittent or the effective distance is significantly decreased, replace the original battery with a new type CR2025 3V $\overline{=}$ lithium battery as follows:

1. Unlock ① and slide out the battery holder ② from the remote control case.
2. Replace the weak/dead battery with a new one. Be sure the battery is installed correctly. The remote will not work if the battery is installed with wrong polarity.
3. Insert the battery holder back into the battery slot.

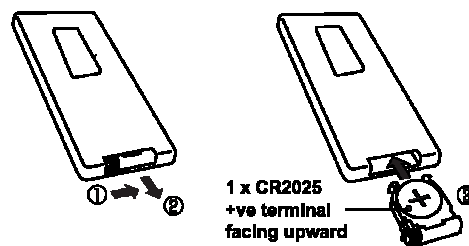

BATTERY NOTE AND CARE

- Danger of explosion if the battery is replaced incorrectly. Replace only with the same type battery.
- Only use a good quality known brand battery to ensure the longest life and best performance.

- If the unit is not used for an extended period of time, remove the battery. An old or leaking battery can cause damage to the remote and may void the warranty.
- Do not dispose of batteries in fire. Batteries may leak or explode.
- Do not try to recharge batteries that are not intended to be recharged; they can overheat, rupture and leak (Follow battery manufacturer's directions).
- Only an adult should replace the battery.

DOCKING YOUR iPhone / iPod touch / iPod nano

DOCKING iPhone 5 and iPod touch (5 Gen.)

Option 1 (without case or bumper on iPod/iPhone)

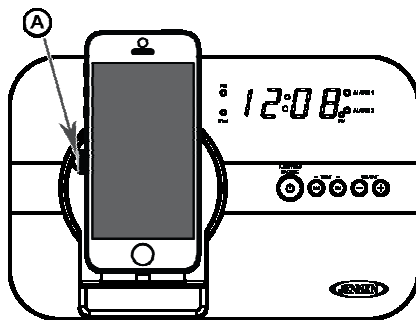

PORTRAIT MODE

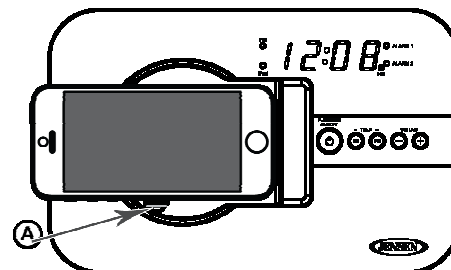

LANDSCAPE MODE

1. With the Support Tab set vertical (A) (foam pad facing the iPod/iPhone).
2. Dock your iPod/iPhone onto the Lightning connector in Portrait mode as shown above.
3. Rotate the dock 90 degrees counterclockwise to change to landscape mode.

Option 2 (with case or bumper on iPod/iPhone)

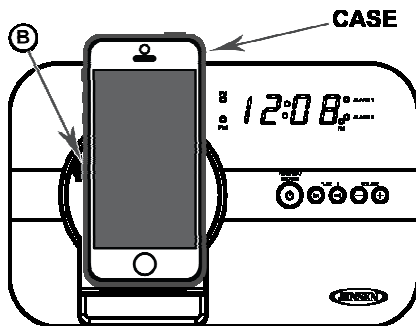

PORTRAIT MODE

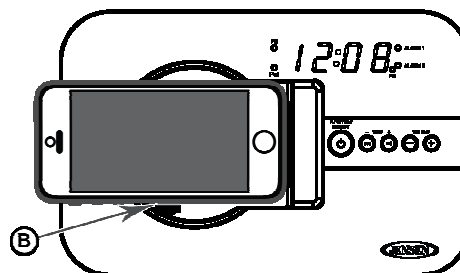

LANDSCAPE MODE

1. Remove the Support Tab.
2. Reinsert the Support Tab with the foam pad facing away from the iPod/iPhone (B).
3. Dock your iPod/iPhone onto the Lightning connector in Portrait mode as shown above.
4. Rotate the dock 90 degrees counterclockwise to change to landscape mode.

Note: Since there are many different types of Apple device cases on the market, some of the cases might be too thick and not suitable for the docking with case on the iPod/iPhone. If you experience this problem, please remove the case and follow the docking instructions in Option 1.

DOCKING iPod nano (7 Gen.)

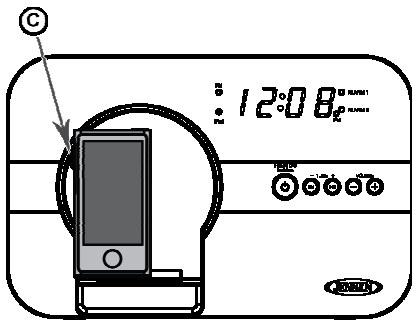

PORTRAIT MODE

1. Remove the Support Tab. (C) .
2. Dock your iPod nano onto the Lightning connector in Portrait mode as shown above.

Note: It is not recommended to use the landscape mode with the iPod nano. Only use the iPod nano in portrait mode.

DOCKING iPhone 6

Recommend without case or bumper on iPhone 6)

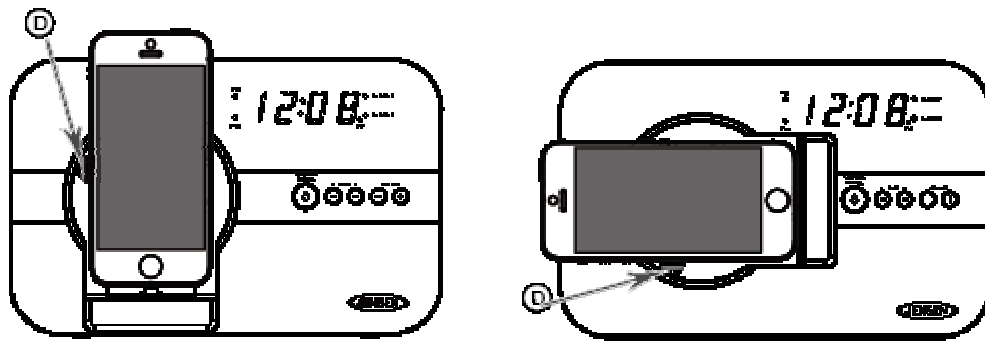

1. Remove the Support Tab (A)
2. Insert the Support Tab for iPhone 6 (D)
3. Dock your iPhone 6 onto the Lightning connector in Portrait mode as shown above.
4. Rotate the dock 90 degrees counterclockwise to change to landscape mode.

DOCKING iPhone 6+

Recommend without case or bumper on iPhone 6+)

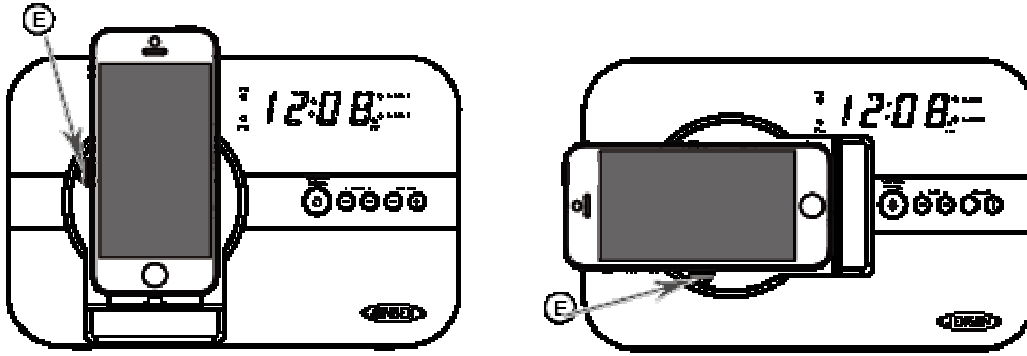

3. Remove the Support Tab **(A)**
4. Insert the Support Tab for iPhone 6+ **(E)**
5. Dock your iPhone 6+ onto the Lightning connector in Portrait mode as shown above.
4. Rotate the dock 90 degrees counterclockwise to change to landscape mode.

PLAYING AND CHARGING YOUR iPhone / iPod touch / iPod nano



CHARGING YOUR APPLE DEVICE

Even when the JiLS-525iB is in standby mode, once your iPod nano (7 Gen.), iPhone 5 or iPod touch (5 Gen.) is docked onto the Lightning Connector, the charging will start automatically.

LISTENING TO MUSIC ON YOUR APPLE DEVICE





1. Dock your iPhone/iPod onto the lightning connector located on the docking station.

Note: Please be careful when docking the iPhone/iPod onto the 8-pin lightning connector located on the iPhone/iPod or in the JiLS-525iB.

2. Press the  button to turn on the unit.
3. Press the FUNCTION button to select iPod mode. The iPod mode indicator LED "iPod" lights.
4. Press the  button to start, pause or resume iPhone/iPod playback.
5. Adjust the sound level by pressing the VOLUME + / - button.

Note: The volume level cannot be adjusted using the volume control on your iPhone/iPod after being docked.

iPhone / iPod PLAYBACK CONTROL

- Press the  button to pause or resume the iPhone/iPod playback.
- Press the  /  button to skip to the next or previous song.
- Press and hold the  /  button for fast-forwarding or fast-rewinding during playback.

ENERGY SAVING NOTE

In order to save energy, the unit is designed with the following feature:

If iPod mode is selected and no iPhone/iPod is docked within **10 minutes**, the unit will turn off (standby mode) automatically.

RADIO OPERATION

FM ANTENNA

Fully unwrap and extend the FM antenna wire for the best FM radio reception.

RADIO TUNING

1. Press the  button to turn on the unit.
2. Press the FUNCTION button to select FM radio mode. The FM radio mode indicator LED turns on.
3. To manually tune to a desired station, repeatedly press the TUNE + / - button.
4. To automatically search for stations with strong signals, press and hold the TUNE + / - button until the frequency digits on display begins to scan then release the button. The tuner will stop on the first strong signal it finds.
5. You may press the FM ST/MO button to select FM radio Stereo or Mono receiving mode, where the stereo indicator “**o fl**” and mono indicator “**o FF**” display respectively.

Notes:

- Manual tune to select weaker stations that might be skipped during automatic tuning.
- If the automatic tuning does not stop on the exact frequency of the station, for example, it stops on 88.9 MHz instead of 88.8 MHz, use the manual tuning method to "fine tune" to the exact frequency of the desired station.

PRESET RADIO STATION CHANNEL

The unit allows you to store up to 20 FM stations for easy recall at any time.

1. Press the  button to turn on the unit.
2. Press the FUNCTION button to select FM radio mode.
3. Tune to the radio station you want to store in memory by using the TUNE + / - button.
4. Press the MEMORY button, where the preset channel number appears on display and blinks.
5. To select desired preset station number, press the TUNE + / - button.
6. To confirm preset location, press the MEMORY button.
7. Repeat steps 3 to 6 to store other stations.

Notes:

1. There is a few seconds delay when programming, after this delay time, the unit will automatically switch back to normal tuner mode.
2. You can overwrite a preset station by overwriting and storing the new frequency in its place.

RECALLING A PRESET STATION

In radio mode, press the PRESET button then press the TUNE + / - button from the main unit (or the CH + / - button from the remote control) to select the desired preset radio channel. The preset channel number will appear on display.



BLUETOOTH OPERATION

PAIRING (LINKING) A BLUETOOTH ENABLED CELL PHONE OR OTHER BLUETOOTH ENABLED DEVICE to the JiLS-525iB.

1. With the power on, tap the FUNCTION button repeatedly to select Bluetooth mode. The LED display will show “bt” for about 10 minutes. The JiLS-525iB is ready to pair (link) with your Bluetooth device.
2. Turn on the Bluetooth feature of your cell phone and enable the search or scan feature to find the JiLS-525iB.

3. Select " JiLS-525iB " from the device list when it appears on your device screen. If required, enter the pass code "0000" to pair (link) the JiLS-525iB with your cell phone.
4. After successfully pairing (linking) your cell phone with the JiLS-525iB, the LED display will change to show "bt" steadily for few seconds then show current clock. You can play music from your cell phone wirelessly to the JiLS-525iB.









Note: If you want to connect the JiLS-525iB to another cell phone after pairing successfully, then you need to turn off the Bluetooth on the paired cell phone first if it is in range before going through the above steps. Otherwise, the JiLS-525iB will automatically reconnected to previously linked cell phone.

5. Press the VOLUME +/- button to adjust the desired volume level.
6. To turn off the JiLS-525iB Bluetooth, press the  POWER button on the remote control or press and hold the  button to turn the unit to standby mode. Don't forget to also turn off the Bluetooth feature on your cell phone.

Notes:

1. Refer to manual of your cell phone or other Bluetooth enabled device for Bluetooth operation, since it may vary from model to model.
2. Pairing mode will be canceled and unit will be turned to Standby mode if pairing is unsuccessful within 10 minutes.
3. If your Bluetooth enabled device does not support A2DP, it will not play the music through the speaker, even after it's paired (linked).
4. If you are pairing (linking) your computer to the JiLS-525iB using Bluetooth, you may need to set the JiLS-525iB as your computer's default sound device.

PLAYBACK MUSIC ON YOUR BLUETOOTH DEVICE

1. Press the  POWER button to turn on the unit.
2. Turn on Bluetooth of your cell phone or device which has been successful pairing with JiLS-525iB before, press the FUNCTION button to select Bluetooth mode, the "bt" message appears on the LED display and blinking.
3. After the Bluetooth device is connected with the JiLS-525iB, press the PLAY/PAUSE  button to start playback music in your cell phone or Bluetooth device.
4. Press the PLAY/PAUSE  button to pause or resume playback.
5. Press the VOLUME +/- button to adjust your desired volume level.
6. Press the  or  button on the remote control or main unit to select the desire music track. Press and hold the  or  button on the remote or main unit for fast-rewinding or fast-forwarding during playback.
7. Press the  POWER button on the remote control or press hold the  button on the main unit to turn off the unit after listening.

Re-linking to the cell phone

If your cell phone or Bluetooth device is already paired with the JiLS-525iB, but became unlinked at some point, even with both Bluetooth devices turned on. You can re-link them by:

1. Press and hold the PAIR button on the remote control or ►||/PAIR button on the main unit to re-link your cell phone. The "PAIR" message will appear in LED display and then "bt" message flashing for about 10 minutes.
2. Select JiLS-525iB on your cell phone for linking. Display message will change to show "bt" steadily for few seconds and then change to show current time if the JiLS-525iB and your cell phone have been re-linked successfully.
3. You can also re-link the JiLS-525iB by using Bluetooth operation of your cell phone. Please refer to operation manual of your cell phone for more information.

USING THE AUXILIARY INPUT (AUX-IN)

This unit features an Aux-in Jack (auxiliary input) for connecting an external audio device like an MP3 player, CD player and older, non-dockable iPods (except 3rd generation iPod shuffle) and listening to the audio from that device through the docking speakers.

1. Use an audio cable (not included) with one 3.5 mm stereo plug on both ends.
2. Plug one end of the cable into the AUX-IN Jack on the back of the main unit and the other end into the Line-out Jack or Headphone Jack of your external audio device.
3. Turn on the external audio device.
4. Press the  button to turn on the unit.
5. To select auxiliary audio input, press the FUNCTION button. The "AU" indicator will display few seconds.
6. The output volume can now be controlled using the VOLUME + or VOLUME – buttons on the remote and main unit. Operate all other functions on the auxiliary device as usual.

Note:

- If the Line Out Jack of your external device is connected, then you only need to adjust the volume control of this unit. If the Headphone Jack of your external device is connected, then you may need to adjust both the volume control of your external device and the volume control of this unit to obtain the most comfortable volume level.
- Press and hold the Power  button to turn off the system when you finish listening. Don't forget to switch off the power of your external device as well.

ENERGY SAVING NOTE

In AUX-In mode, if no audio signal (music) is detected at the AUX-IN input after around 10 minutes, the unit will turn off (standby mode) automatically.

PRESET EQ AND TREBLE / BASS SETTINGS

The unit is designed for you to select the preset EQ and Treble / Bass settings.

When the unit is powered on (in iPod, Aux-In or Radio mode), you can select 4 preset EQ or setting Treble / Bass as following steps.

TO SELECT PRESET EQ

1. Press the EQ button entering preset EQ mode.
2. Each press of the EQ button will scroll through following selection.

Display Symbol	Meaning
E : 0	NORMAL
E : 1	JAZZ
E : 2	CLASSIC
E : 3	ROCK
E : 4	POP

3. The selected preset EQ indicator will display few seconds.

TO SET TREBLE / BASS

1. Press and hold the EQ button to enter Bass setting mode.
The display shows the indicator "b" and the base level digit.
2. Tap the TUNE + / - button to adjust to the desired Bass level.
3. Tap the EQ button again entering Treble setting mode.
The display shows the indicator "t" and the treble level digit.
4. Tap the TUNE + / - button to adjust to the desired Treble level.
5. Press the EQ button to exit Bass / Treble setting mode.

SETTING THE CLOCK

SETTINGS

When the unit is OFF (Standby mode):

Set 12/24 Hour format

1. Press the MODE button entering 12/24 hour format setting mode.
2. Press the TUNE + / - to select 12 or 24 hour display format.

Set Clock

3. Press the MODE button again and the clock digits blink.
4. Press the TUNE + / - button to set hour.
5. Press the VOLUME + / - button to set minute.

Exit setting mode

6. To save all settings, press the MODE button or wait for a few seconds to exit the setting mode.

ALARM OPERATION

The unit incorporated dual alarm timer, ALARM 1 and ALARM 2. You may set the two alarm time individually.

It wakes you up from Beep Alarm, FM Radio or iPhone/iPod.

When the unit is OFF (Standby mode):

Select wake up alarm source

1. Press and hold the ALARM SET button entering alarm source setting mode. The ALARM 1 (2) LED indicator blinks.
2. Tap the VOLUME + / - button to select alarm source BEEP ("bu"), RADIO ("rad") or iPhone/iPod (IPod).

Setting the alarm time

3. Tap the ALARM SET button again. The ALARM 1 (2) LED indicator blinks.
4. Tap the TUNE + / - button to set alarm hour.
5. Tap the VOLUME + / - button to set alarm minute.

Save settings and activate alarm function

6. To save all settings and exit the setting mode, tap the ALARM SET button or wait for a few seconds.

Enable daily alarm

1. Tap the ALARM SET button once to enable alarm 1 and the ALARM 1 LED indicator lights steadily.
2. Tap the ALARM SET button again to enable alarm 2 and the ALARM 2 LED indicator lights steadily.
3. Tap the ALARM SET button once more to enable both alarm 1 & 2 and both ALARM 1 & ALARM 2 LED indicators light steadily.
4. To disable all alarms, tap the ALARM SET button again and both ALARM 1 & ALARM 2 LED indicators will be off.

To activate the daily alarm, the corresponding alarm source LED indicator (ALARM 1 / ALARM 2) should appear on the display.

Notes:

- When "Wake to Radio" is selected, make sure the radio station you want to wake to is tuned.
- If "Wake to iPhone/iPod" is selected but your iPhone/iPod has not been docked, the alarm source will be redirected to the Beeper Alarm automatically when alarm time is reached. Also make sure the music that you want to play on your Apple device is selected before you place the unit into standby mode.

Wake to Beep Alarm

- When the alarm time is reached, the ALARM 1 (ALARM 2) LED indicator blinks and the beep alarm will sound for 1 Minute.
- The unit automatically goes into Auto-snooze mode if no other button has been pressed. The ALARM 1 (ALARM 2) LED indicator blinks.
- The beep alarm turns off for the snooze time (around 10 minutes) then comes on again.
- You may also activate the snooze function manually after the alarm sounds by pressing the SNOOZE button. The beep alarm stops for the snooze time then comes again.
- The snooze operation (including auto-snooze and manual snooze) can be repeated within 50 minutes from the set alarm time.
- In the case at the 60 minutes from the set alarm time, the unit resets itself for the following day.
- To cancel the snooze before the time expires, press the ALARM OFF button.
- To stop the alarm immediately after the beep alarm, you can also press the ALARM OFF button. It resets itself for the following day. The ALARM 1 (ALARM 2) LED indicator will light steadily.



Wake to Radio or iPhone/iPod

- When the alarm time is reached, the selected alarm source (Radio or iPhone/iPod) will automatically turn on. It starts softly and gradually becomes louder. The ALARM 1 (ALARM 2) LED indicator blinks.
- It plays for up to 60 minutes from the set alarm time then shuts off and resets itself for the following day. The ALARM 1 (ALARM 2) LED indicator will light steadily.
- During the activation of the alarm source, you may press the SNOOZE button to activate the snooze function, the ALARM 1 (ALARM 2) LED indicator blinks. The alarm stops for the snooze time (around 10 minutes) then turns on again.
- The manual snooze operation can be repeated within 50 minutes from the set alarm time.
- To cancel the snooze before the time expires, press the ALARM OFF button.
- The unit resets itself for the following day after 60 minutes from the set alarm time has passed.
- To stop the alarm immediately after the alarm sounds, you may also press the ALARM OFF button. It resets itself for the following day.

SLEEP TIMER FUNCTION

SLEEP TO TIMER

This feature allows you to fall asleep to the radio or iPod/iPhone music for up to 90 Minutes. The unit shuts off automatically when the time expires.

1. Press the  button to turn the unit on.
2. Tune to the desired radio station in radio mode or playback iPhone/iPod music in iPod mode.
3. To select the sleep timer to turn the unit off after 15, 30, 45, 60 or 90 minutes, tap the SLEEP button repeatedly. The unit plays for the selected length of time then automatically turns off.
4. To view the remaining sleep time, tap the SLEEP button once.
5. To turn the unit off before the sleep timer counts down to zero, press and hold the  button at any time.

Notes:

- If you are falling asleep to music from an external device connected to the AUX input, the sleep timer will shut off the power to this system but it will not turn off the external device.

CHARGING YOUR SMART PHONE OR PORTABLE DEVICE

This unit features a USB port for charging your portable device (iPod, iPhone, Android phone, etc.) when used with the USB charging cord that came with your device.

1. Plug the standard end of the USB cable (not included) into the USB port located on the back of the JiLS-525iB. Plug the small end of the USB cable into the device you wish to charge.
2. Observe the battery charge indicator on your device and the charging will start immediately.
3. Unplug the cable when your device is charged.

CAUTION:

Before charging, please refer to the user manual of the device you wish to charge to make sure the charging current required does not exceed 1Amp (1,000 mA) of charging current. Overloading the charge circuit may damage the JiLS-525iB and void the warranty.

1. The USB charging port of this unit supplies a DC 5V output at 1000mA maximum current to charge your smart phone or portable device battery and it cannot support any other voltage range.
2. Make sure the device you want to charge has a battery charge rating of DC 5V only.
3. The USB port of this unit is designed for smart phone or portable device battery charging only and it cannot support data transfer or connect to computer.
4. Do not connect the USB port of this unit to other external power charger USB ports, it may damage both units and void the warranty.

NOTE:

- 1.) Some smart phones and portable devices use proprietary USB connections and circuitry, so they may not charge when plugged into the USB port. Please refer to your device user manual before you attempt to charge them.
- 2.) It is normal for the JiLS-525iB to be warm while the USB port is in use and charging your smart phone or portable device.
- 3.) Unplug the cable when your device is charged.

RESETTING THE UNIT

If this unit was exposed to a power surge or electric shock, it is possible that the internal micro-controller may lock up and the unit will not respond to any commands from the front panel controls or remote control. In this event, you can do one of the following:

1. Unplug the DC power cord plug of the AC Adaptor from the unit and then reconnect after about 10 seconds.
2. Use a straightened paper clip, toothpick or similar objects to press the Reset Button which is located at back of the unit.

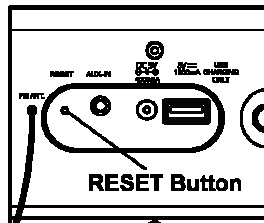

Warning:

Do not use sharp, pointed object to press the Reset Button. It can damage the switch inside the unit.

RESETTING THE ALARM SETTING AND MEMORY

Pressing the RESET button which is only reset the unit to normal operation from the abnormal situation. It will not clear the FM radio preset station memory or alarm setting. In order to do so, you may implement following steps.

- (1) Connect the DC plug of the AC Adaptor from the unit.
- (2) Press and hold the EQ button of the unit. The display show "CLr" after detach and reconnect the DC plug.

CARE AND MAINTENANCE

CLEANING THE UNIT

- To prevent fire or shock hazard, disconnect your unit from the AC adaptor and Apple device when cleaning.
- The finish on the unit may be cleaned with a dust cloth and cared for as other furniture. Use caution when cleaning and wiping the plastic parts.
- If the cabinet becomes dusty wipe it with a soft dry dust cloth. Do not use any wax or polish sprays on

the cabinet.

- If the unit becomes dirty or smudged with fingerprints it may be cleaned with a soft cloth slightly dampened with a mild soap and water solution. Never use abrasive cloths or polishes as these will damage the finish of your unit. Never allow any water or other liquids to get inside the unit while cleaning !

TROUBLESHOOTING GUIDE

Symptom	Possible Problem	Solution
The unit does not respond (no power).	AC Adaptor is not plugged into a wall outlet or the connector is not plugged into the DC Jack on the back of the unit properly.	Plug the AC adaptor into a wall outlet and plug the connector into the DC Jack on the unit again with special attention.
	Wall outlet is not functioning.	Plug another appliance to the same outlet to confirm it is working.
Apple device does not respond to the speaker system.	Apple device is not installed properly.	Remove your Apple device from the dock and check for obstruction on the connectors in the dock and on your Apple device. Then reseal it on the dock.
	Apple device is locked up.	Please make sure that your Apple device is working properly before docking into the unit. Please refer to your Apple device manual for info on resetting the device.
Apple device does not recharge.	Apple device is not installed properly.	Remove your Apple device from the dock and check for obstruction on the connectors in the dock and on your Apple device. Then reseal it in the dock.
Sound is distorted.	Volume level is set too high.	Decrease the volume.
	Sound source is distorted.	If the Apple device original sound source is poor quality, distortion and noise is easily noticed with high-power speakers. Try a different audio source such as a music CD. If you are using an external sound source like older generation of iPod, try reducing the output volume on the device itself. Also try changing the EQ setting of your Apple device.
Unit gets warm after extended play at high volume.	This is normal.	Turn the unit off for a period of time or lower volume.

SPECIFICATIONS

POWER REQUIREMENT

<u>Main Unit</u>	AC-DC adaptor	Input:	AC 120V~ 60Hz	
		Output:	DC 5V= 3500mA	
<u>Clock / Memory back-up battery</u>	1 x 3V= type CR2032 Lithium battery			
<u>Remote Control</u>	1 x 3V= type CR2025 Lithium Battery			
OUTPUT POWER	2 x 2W			

LICENSE AND SPECTRA GREEN NOTICES

"Made for iPod" and "Made for iPhone" mean that an electronic accessory has been designed to connect specifically to iPod or iPhone respectively and has been certified by the developer to meet Apple performance standards. Apple is not responsible for the operation of this device or its compliance with safety and regulatory standards. Please note that the use of this accessory with iPhone or iPod may affect wireless performance.

iPhone, iPod, iPod nano, iPod shuffle and iPod touch are trademarks of Apple Inc., registered in the U.S. and other countries.

Lightning is a trademark of Apple, Inc.

The *Bluetooth*® word mark and logos are registered trademarks owned by Bluetooth SIG, Inc. and any use of such marks by Spectra Merchandising Intl, Inc. is under license. Other trademarks and trade names are those of their respective owners.



At Spectra, environmental and social responsibility is a core value of our business. We are dedicated to continuous implementation of responsible initiatives with an aim to conserve and maintain the environment through responsible recycling. Please visit us at <http://www.spectraintl.com/green.htm> for more information on Spectra's green initiatives or to find a recycler in your area.

**90 DAY LIMITED WARRANTY AND SERVICE
VALID IN THE U.S.A ONLY**

SPECTRA MERCHANDISING INTERNATIONAL, INC. warrants this unit to be free from defective materials or factory workmanship for a period of 90 days from the date of original customer purchase and provided the product is utilized within the U.S.A. This warranty is not assignable or transferable. Our obligation under this warranty is the repair or replacement of the defective unit or any part thereof, except batteries, when it is returned to the SPECTRA Service Department, accompanied by proof of the date of original consumer purchase, such as a duplicate copy of a sales receipt.

You must pay all shipping charges required to ship the product to SPECTRA for warranty service. If the product is repaired or replaced under warranty, the return charges will be at SPECTRA's expense. There are no other express warranties other than those stated herein.

This warranty is valid only in accordance with the conditions set forth below:

1. The warranty applies to the SPECTRA product only while:
 - a. It remains in the possession of the original purchaser and proof of purchase is demonstrated.
 - b. It has not been subjected to accident, misuse, abuse, improper service, usage outside the descriptions and warnings covered within the user manual or non-SPECTRA approved modifications.
 - c. Claims are made within the warranty period.
2. This warranty does not cover damage or equipment failure caused by electrical wiring not in compliance with electrical codes or SPECTRA user manual specifications, or failure to provide reasonable care and necessary maintenance as outlined in the user manual.
3. Warranty of all SPECTRA products applies to residential use only and is void when products are used in a nonresidential environment or installed outside the United States.

This warranty gives you specific legal rights, and you may also have other rights which vary from state to state. TO OBTAIN SERVICE please remove all batteries (if any) and pack the unit carefully and send it freight prepaid to SPECTRA at the address shown below. IF THE UNIT IS RETURNED WITHIN THE WARRANTY PERIOD shown above, please include a proof of purchase (dated cash register receipt) so that we may establish your eligibility for warranty service and repair of the unit without cost. Also include a note with a description explaining how the unit is defective. A customer service representative may need to contact you regarding the status of your repair, so please include your name, address, phone number and email address to expedite the process.

IF THE UNIT IS OUTSIDE THE WARRANTY PERIOD, please include a check for \$35.00 to cover the cost of repair, handling and return postage. All out of warranty returns must be sent prepaid.

It is recommended that you contact SPECTRA first at 1-800-777-5331 or by email at custserv@spectraintl.com for updated information on the unit requiring service. In some cases the model you have may be discontinued, and SPECTRA reserves the right to offer alternative options for repair or replacement.

SPECTRA MERCHANDISING INTERNATIONAL, INC.
4230 North Normandy Avenue,
Chicago, IL 60634, USA.
1-800-777-5331

To register your product, visit the link on the website below to enter your information.
<http://www.spectraintl.com/wform.htm>.

0615

Printed in China