



C3-RS-603

PROFESSIONAL REMOTE CAR STARTER
With Two Way data Port

INSTALLATION MANUAL



Compatible



THIS PRODUCT IS DESIGNED FOR PROFESSIONAL INSTALLATION ONLY

TABLE OF CONTENTS

Installer Warning	3
System Wiring Diagram	4
H1 - Main 6 Pin Heavy Gauge Harness	5
H2 – 6 Pin Harness	6
H3 – 8 White Connector Harness	6
Installation Factory Immobilizer Systems.....	8
H4 – 2 Pin Blue connector	9
H5 – 3 Pin Red Antenna/Receiver Connector	9
H6 – 3 Pin Door Lock Harness... ..	9
H7- SERIAL DATA PORT CONNECTION RS-232 Port	10
Remote Transmitter Programming	11
Alarm Feature “I” Programming	11
Alarm Feature “II” Programming	12
Alarm Feature “III” Programming	12
RPM Learning	13
Return To Factory Default Settings	13
To Remote Start The Vehicle	13
Shutdown Diagnostics	13
Trouble Shooting	14
Testing Your Installation (Neutral Safety Switch)	14
Notes	16

This device complies with part 15 of the FCC rules.

Operation is subject to the following two conditions.

- (1) This device may not cause harmful interference, and
- (2) This device must accept any interference received, including interference that may cause undesired operation.

INTRODUCTION

INSTALLER WARNINGS

This Remote Starter System is designed to be installed on fuel-injected vehicles with an automatic transmission ONLY.

- **Never install this remote starter on a manual transmission vehicle.**
- This system must be installed and wired through a safety switch so it will not start in any forward or reverse gear.
- Some automatic transmission vehicles [mainly older GM vehicles with a purple starter wire] have a mechanical-type neutral safety switch instead of electrical safety switch. The mechanical type does not interrupt the starter circuit when the transmission is any gear and does not offer the 100% level of safety required for remote starting purposes. Therefore, our system should never be installed on any vehicle that uses a mechanical type park safety switch.
- Once you install this system, you must verify that the vehicle will not start any forward or reverse gear. Regardless of the type of vehicle.
- Read operation manual for operating and programming routine.
- Do not install any component near the brake, gas pedal or steering linkage.
- Some vehicles have a factory installed transponder immobilizer system that can severely complicate the installation. There is possibility that this system cannot be installed on some immobilizer-equipped vehicles.
- Most vehicles have an SRS air bag system. Use extreme care and do not probe any wires of the SRS system.
- Disconnect the car battery before connecting work on the vehicle.
- Check behind all panels before drilling any holes. Ensure that no wiring harness or other components are located behind the panels that would otherwise be damaged.
- Use conventional crimp lock or bullet connectors on wiring. Poor wiring, i.e. taped joints will possibly introduce unreliability into the alarm system and may result in false alarms or incorrect operation.
- Install wiring neatly under carpets or behind trim to prevent possible damage to wires.
- For the wire operates the current more than 10A. We suggest soldering all connection point. Does not use crimp lock type connectors or wire nuts.

INSTALLATION DIAGRAM

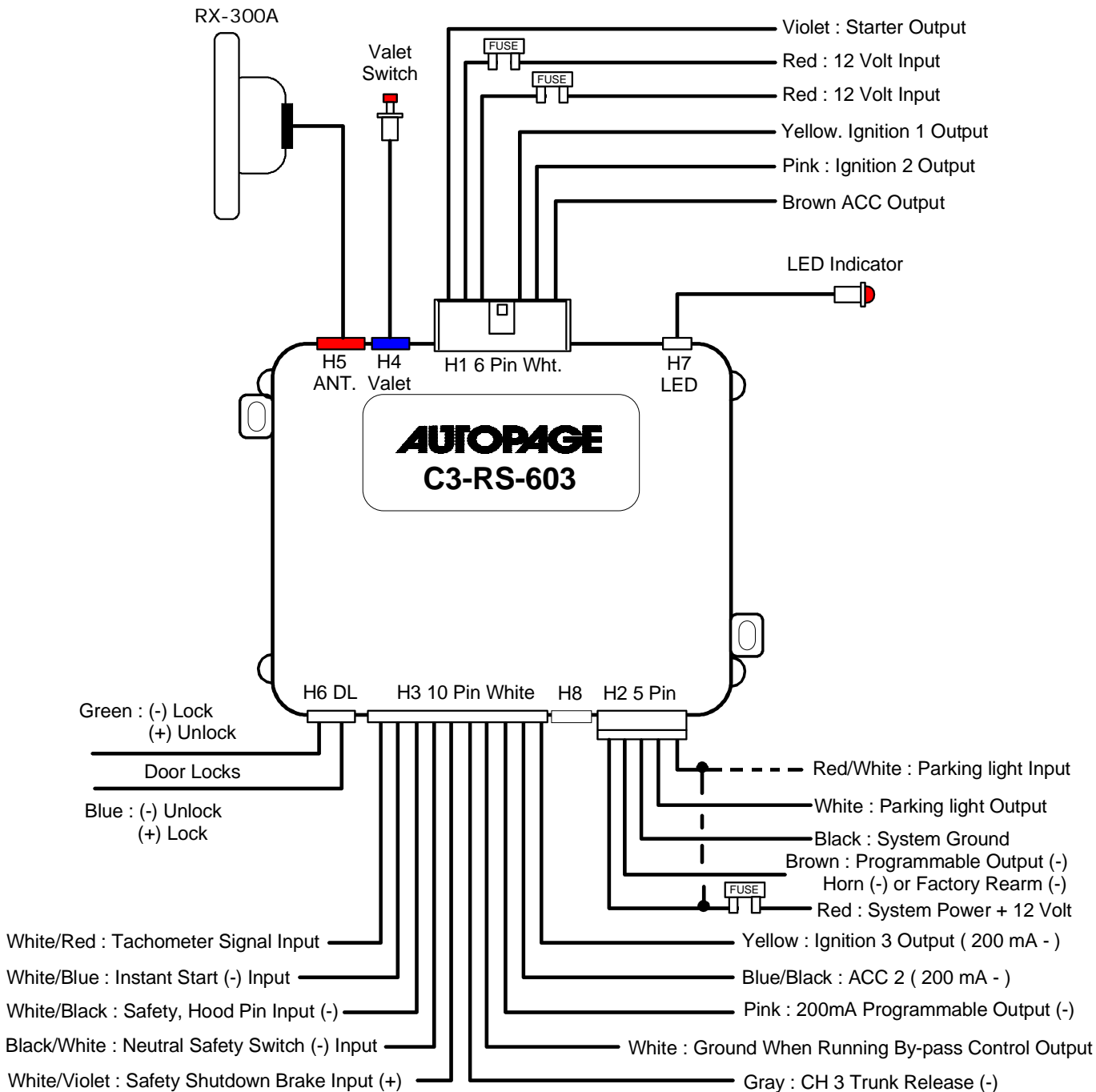

WIRING

Keep wiring away from moving engine parts, exhaust pipes and high-tension cable. Tape wires that pass through holes on the firewall to prevent fraying. Watch out for sharp edges that may damage wires and cause a short circuit.

CAUTION: Do not connect the wire harness to the control module until all wiring to vehicle is complete.

H1: 6 PIN HEAVY GAUGE WIRING CONNECTIONS:

Remember! What the system does to start a vehicle, duplicates the function of the ignition key switch! Below, we will explain the three basic functions of the ignition switch. Since this installation will require analysis of the ignition switch functions, we recommend making the three connections below at the ignition switch harness directly.

H1/1. VIOLET WIRE—Starter Output

Careful consideration for the connection of this wire must be made to prevent the vehicle from starting while in gear. Understanding the difference between a mechanical and an electrical Neutral Start Switch will allow you to properly identify the circuit and select the correct installation method. In addition you will realize why the connection of the safety wire is required for all mechanical switch configurations.

Failure to make this connection properly can result in personal injury and property damage.

In all installations, it is the responsibility of the installing technician to test the remote start unit and assure that the vehicle can not start via RF control in any gear selection other than park or neutral.

In both mechanical and electrical neutral start switch configurations; the connection of the VIOLET wire will be made to the low current start solenoid wire of the ignition switch harness. This wire has +12 volts when the ignition switch is turned to the "START" (CRANK) position only. This wire will have 0 volts in all other ignition switch positions.

NOTE: This wire must be connected to the vehicle side of the starter cut relay (when used). For the electrical neutral switch configuration, this connection must be made between the starter inhibit relay (when used) and the neutral safety switch as shown in the following diagram.

Failure to connect this wire to the ignition switch side of the neutral safety switch can result in personal injury and property damage. SEE NEUTRAL START SAFETY TEST FOR FURTHER DETAILS.

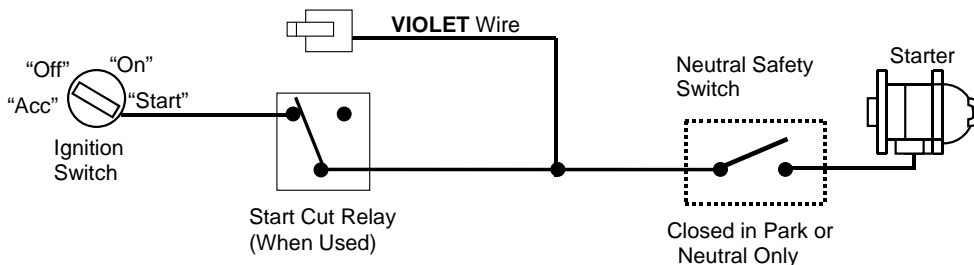

H1/2 & H1/3. RED WIRE (2)-- +12V Power Input

Remove the two 20A fuses prior to connecting these wires and do not replace them until all connectors have been plugged into the control module. These wires are the source of current for all the circuits the starter unit will energize. They must be connected to a high current source. Since the factory supplies (+) 12V to the key switch that is used to operate the motor, it is recommended that these wires be connected there.

Note: If the factory supplies two separate (+) 12V feeds to the ignition switch, connect one RED wire of the unit to each feed at the switch.

H1/4. YELLOW WIRE – Ignition 1 Output

Connect the YELLOW wire to the ignition 1 wire from the ignition switch. The ignition wire should receive "12 volts" when the ignition key is in the "ON" or "RUN" and "START" or "CRANK" position. When the ignition is turned "OFF", the ignition wire should receive "0" voltage. **The YELLOW wire must be connected.**

H1/5 PINK WIRE – Ignition 2 Output

Some vehicles have [2] ignition wires that must be power. Connect the PINK wire to the ignition 2 wire from the ignition switch. The ignition wire should receive "12 volts" when the ignition key is in the "ON" or "RUN" and "START" or "CRANK" position. When the ignition is turned "OFF", the ignition wire should receive "0" voltage. If the PINK wire is not used, cap the end of the wire.

H1/6 BROWN WIRE – Accessory Output (Heater /ACC Output) –

Connect the BROWN wire to the accessory wire in the vehicle that powers the climate control system.

An accessory wire will show + 12 volts when the ignition switch is turned to the "ACCESSORY" or "ON" and "RUN" positions, and will show 0 Volts when the key is turned to the "OFF" and "START" or "CRANK" position. There will often be more than one accessory wire in the ignition harness. If selected, the correct accessories wire will power-up the vehicle's climate control system. Some vehicles may have separate wires for the blower motor and the air conditioning compressor. In such cases, it will be necessary to add a relay to power the second accessory wire.

H2: 5 PIN WIRE HARNESS:**H2/1. RED/WHITE WIRE –PARKING LIGHT RELAY INPUT --**

The RED/WHITE wire is the input to the flashing parking light relay. The connection of the RED/WHITE wire will determine the output polarity of the flashing parking light relay.

If the vehicle you are working on has +12volt switched parking lights, you don't need to connect this wire. This wire already connected to +12volt. If the vehicle's parking lights are ground switched, cut the RED/WHITE wire, connect the RED/WHITE wire to chassis ground.

H2/2. WHITE WIRE -- PARKING LIGHT RELAY OUTPUT (+12 V 10A OUTPUT) --

Connect the WHITE wire to the parking light wire coming from the headlight switch. Do not connect the WHITE wire to the dashboard lighting dimmer switch. (Damage to the dimmer will result). The limitation of the WHITE wire is 10 AMP max. Do not exceed this limit or damage to the alarm and parking light relay will result.

H2/3. BLACK WIRE -- SYSTEM GROUND –

This is main ground connection of the alarm module. Make this connection to a solid section of the vehicle frame. Do not connect this wire to any existing ground wires supplied by the factory wire loom; make the connection to the vehicle's frame directly.

H2/4. BROWN WIRE – (-) 200mA PROGRAMMABLE OUTPUT (See Feature I - 3 Programming)

HORN OUTPUT – (Factory Default Setting)

This wire is provided to use the existing vehicle's horn as the alarm system's optional's warning audible device. It's a transistorized low current output, and should only be connected to the low current ground output from the vehicle's horn switch.

FACTORY SECURITY RE-ARM SIGNAL OUTPUT– (See Alarm Feature I - 3 Programming)

This wire is designed to rearm a factory installed security system. This wire will supply a pulse whenever the remote start times out or is shut down using the transmitter and remote door locking..

H2/5. RED WIRE -- SYSTEM POWER (+12V CONSTANT) --

The RED wire supplies power to the system. Connect this wire to a constant +12 volt source.

H3: 10-PIN MINI WHITE CONNECTOR WIRE HARNESS:**H3/1. WHITE/RED WIRE—Tachometer Signal connection—**

This input provides the remote start system with information about the engine's revolutions per minute (RPM). It can be connected to the negative side of the coil in vehicle with conventional coils. In multi-coil and high energy ignition system locating a proper signal may be more difficult. Once connected, you must Program the Feature **III – 1** to "Tachometer checking type" and teach the system the RPM signal.

To test for a tachometer wire, a multi-meter capable of test AC voltage must be used. The tachometer wire will show between 1V and 6V AC at idle, and will increase as engine RPM increases. In multi-coil ignition system, the system can learn individual coil wire. Individual coil wires in a multi-coil ignition system will register lower amounts of AC voltage. Also, if necessary, the system can use a fuel injector control wire for engine speed sensing. Common locations for a tachometer wire are the ignitions coil itself, the back of the gauges, engine computers, and automatic transmission computers.

IMPORTANT! Do not test tachometer wires with a test light or logic probe. The vehicle will be damaged.

How to find a tachometer wire with your multi-meter

1. Set the ACV or AC voltage (12V or 20V is fine.)
2. Attach the (-) probe of the meter to chassis ground.
3. Start and run the vehicle.
4. Probe the wire you suspect of being the tachometer wire with the red probe of the meter.
5. If this is the correct wire the meter will read between 1V and 6V.

NOTE: No connection of this wire is required, if you use the voltage or timer checking type mode.

H3/2. WHITE/BLUE WIRE – (-) Instant Start & Turn Off Input.

This wire activates and turns off the remote starter each time it sees a momentary ground signal. This wire is normally only used for testing during installation or when activating the module from an after-market system.

H3/3. WHITE/BLACK WIRE : (-) Negative safety shut down input

The WHITE/BLACK wire provides an instant shutdown for the remote start, whenever it is grounded. Connect the wire to the hood pin switch previously installed. This wire must be routed through a grommet in the firewall and connected to the hood pin switch.

Important! This connection is a safety wire and must be connected as shown and tested as specified. Failure to do so may result in personal injury or property damage. See detail of wiring in the following diagram. This wire may also be used if the vehicle brake light circuit switches ground to the brake lights. An isolation diode must be used for ground switched brake light circuits and must be connected to the output of the brake switch.

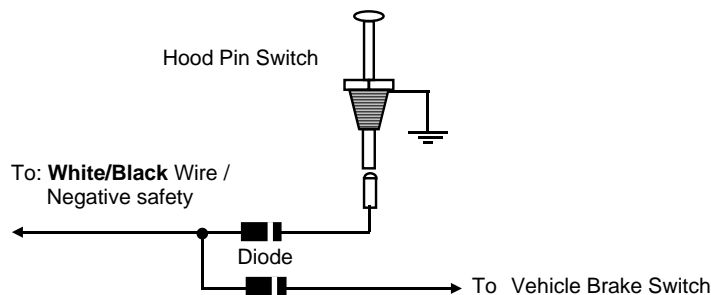

**H3/4 BLACK/WHITE WIRE (-)Neutral Safety Switch Input
(-)Remote Start Enable Toggle Switch Input**

When the BLACK/WHITE wire is grounded, the remote start unit is operable. When this wire is open from ground, the remote start is disabled. This wire must be connected to the vehicles Neutral safety switch!

1. The optional “remote start toggle switch” can be added on to temporarily disable the Remote Start Device, it can prevent the vehicle from being remote started accidentally. This feature is useful if the vehicle is being serviced or stored in an enclosed area. To disable the remote start, move the optional remote start enable toggle switch to the OFF position. To enable the remote start, move the optional remote start enable toggle switch to the ON position.
2. This wire MUST be connected to the PARK/NEUTRAL switch in the vehicle. (See the TESTING YOUR INSTALLATION GUIDE)

IMPORTANT NOTE: Directly connect the BLACK/WHITE wire to the “GROUND” when this wire is not used.

H3/5. WHITE/VIOLET WIRE : Positive safety shut down input

This wire provides an instant shutdown for the remote start, whenever it gets +12volts. If the brake lights switch in the vehicle switches +12 volts to the brake light circuit, connect this wire to the output side of the brake switch. This will allow the remote start to shut down if an attempt is made to operate the vehicle without the key while running under the control of the remote start. In most vehicles, in order to shift gear, the brake pedal must be depressed. The brake input will in turn cause the remote start unit to shut off. See below diagram.

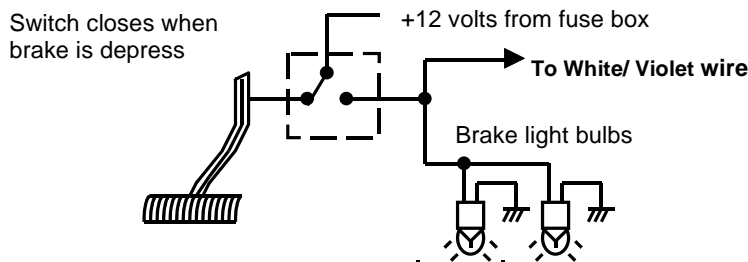

H3/6. GRAY WIRE : (-)200mA Chaneel #3 output -

This will become a 1 second pulse ground by activate channel 3 on transmitter for two seconds, the current capacity of this wire is 200 mA. This feature allows you to remote control trunk release or other electric device.

H3/7. WHITE WIRE: (-) 200 mA Ground output while the engine is starting or running. This wire can be used to activate a by-pass module and will provide a ground output when the engine is starting or running from the remote starter.

**H3/8 PINK WIRE : (-) 200ma PROGRAMMABLE OUTPUT (See Alarm Feature I - 2 Programming)
FACTORY SECURITY DISARM SIGNAL OUTPUT –(Factory Default Setting) --**

This wire is designed to disarm a factory installed security system. This wire sends a negative (-) 1 second pulse upon a remote start and remote door unlocking. Some factory systems must be disarmed to allow remote starting. In most cases, this wire may be connected directly to the factory alarm disarm wire. The correct wire will show negative ground when the key is used to unlock the doors or trunk. This wire is usually found in the kick panel area in the wiring harness coming into the car body from the door.

START STATUS (Shock Sensor Bypass Control) OUTPUT–

This wire is designed to by-pass shock sensor module. This wire will supply an output at all times the remote start is operating plus an additional 3 seconds after the remote start unit turn off.

(-) 200ma KEY SENSOR BY- PASS OUTPUT

This output is for a Key sense wire by-pass that some Chrysler and Toyota vehicles us to activate the remote start. This wire comes on when the start is activated and stays on for 20 seconds.

H3/9.BLUE/BLACK WIRE: Accessory 2 output Programmable start 2 option (See Alarm Feature 3-4 Programming)

This wire provides a 200mA (-) ground output that becomes active a few seconds after the engine running, and remains grounded while running.

H3/10 YELLOW WIRE : (-) 200ma IGNITION 3 OUTPUT–

This wire provides a 200mA (-) ground output that becomes active 4 seconds before the remote start unit initialize, and remains grounded while running.

Ignition 3 output:

Some newer vehicles use a second ignition wire which is required to start and keep the vehicle's engine running. If this is the case, wire an IGN 3 relay (not supplied) as shown below:

Do not connect any vehicle circuits together, they are isolated for a reason.

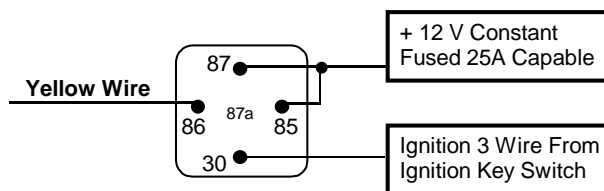

INSTALLATION WITH FACTORY IMMOBILIZER SYSTEMS

Vehicles using a Transponder-type immobilizer:

If the vehicle has transponder system installed, you will need to by-pass the system while the vehicle is operating under the control of the Remote Start Unit. To do this:

1. You will need a transponder key that's already programmed to the vehicle.
2. Remove the trim around the ignition switch.
3. Wrap a thin (28 - 30awg) wire tightly around ignition switch 6 to 8 times and secure it.
4. About 6" down line make another loop of approximately 2" diameter.
5. Place the key inside this loop and secure it to the loop.
6. Connect on end of the (28 - 30awg) wire to pin (87) of the relay module.
7. Connect the other end of the loop wire to Pin (30) of relay module.
8. Connect the pin (85) of the relay module to the ignition wire from the ignition switch.
9. connect the pin (86) of the relay module to the H5/2 Yellow wire of 5-pin mini white connector.

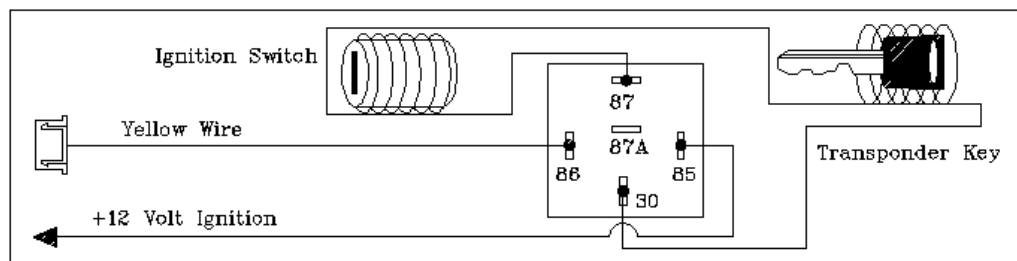

GM VATS KEY OVERRIDE:

If the vehicle has the General Motor VATS system installed, you will need to by-pass the system while the vehicle is operating under the control of the Remote Start Unit. To do this:

1. Measure the resistance of the resistor pellet on the ignition key then select a resistor within 5% of the key's value.
2. Locate the pair of VATS wires in the vehicle, usually a pair of thin gauge wires running from the ignition switch to the VATS control module.
3. Connect the YELLOW wire from Remote Start Unit to TERMINAL #86 of an external relay. Connect terminal #85 of the relay to a fused +12 volt.
4. Cut (#1) wire (as shown), and connect the ignition switch side of the cut wire to terminal #87a of the relay. Connect the other side of the (#1) wire to terminal #30.

5. Connect the previously s resistor from terminal #87 to the second(#2) wire (as shown).

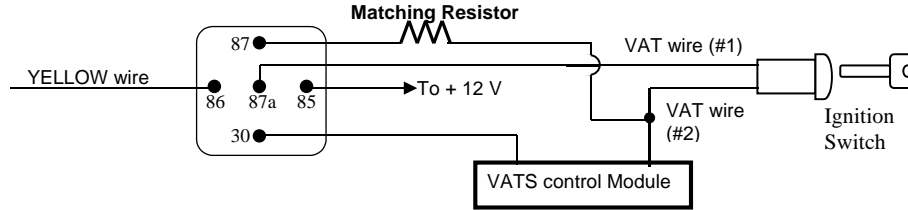

H4. 2 PIN BLUE CONNECTOR FOR THE VALET SWITCH:

Select a mounting location for the switch that is easily accessible to the driver of the vehicle. Mount the valet switch in a hidden but accessible location. Route the valet switch wires to the control module.

H5. Red, 3-PIN CONNECTOR. – Windshield Receiver /Antenna

The windshield receiver/antenna mounts on the windshield (Inside). We suggest you mount it on the lower left or upper left-hand side of windshield.

Warning! Do not mount in such a manner that it obstructs the driver's view.

- **For Optimum Performance the receiver/antenna whip must be vertical facing up.**
- Remove the protective tape backing.
- Carefully align the receiver/antenna and apply to windshield.
- Route the black connector wire behind the trim and connect to receiver/antenna.
- Connect the other end to the control module.
- Special considerations must be made for windshield glass as some newer vehicles utilize a metallic shielded window glass that will inhibit or restrict RF reception. In these vehicles, route the windshield receiver/antenna module away from metallic shielded window glass as far as possible.

H6. White 3-PIN DOOR LOCK CONNECTOR: Note: If the XT-11 optional Ultra Miniature remote is used in a vehicle that will not unlock with the factory remote while the engine is running, the Lock and Unlock wires needs to be connected to unlock and secure the vehicle. This is known to be the case in some Toyota and Lexus models.



NEGATIVE TRIGGER DOOR LOCK SYSTEM

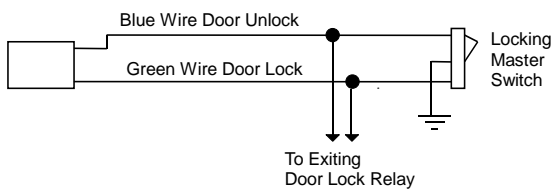

INSTALL NEW DOOR LOCK MOTOR

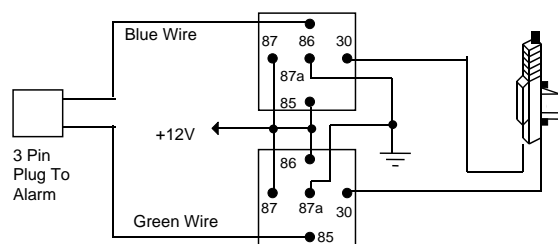

5-WIRE ALTERNATING DOOR LOCK

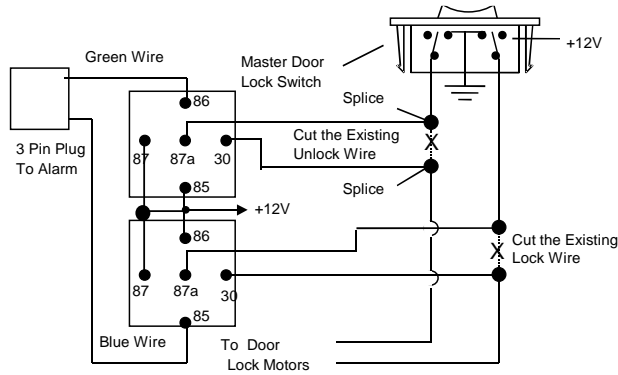

POSITIVE TRIGGER DOOR LOCK SYSTEM

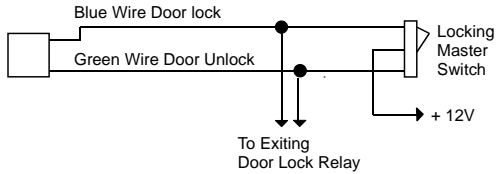

VACUUM OPERATED CENTRAL LOCKING

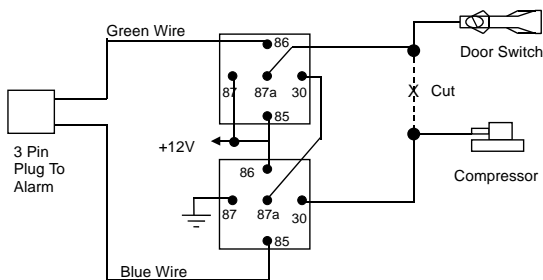

VACUUM OPERATED DOOR LOCKING SYSTEM:

TYPICAL OF MERCEDES BENZ AND AUDI.

Locate the wire under the driver's kick panel. Use the voltmeter connecting to ground, verify that you have the correct wire with the doors unlocked, the voltmeter will receive "12 volts". Lock the doors and the voltmeter will read "0 volt". Move the alligator clip to +12V and the voltmeter will receive "12 volts". Cut this wire and make connections. Be sure to program door lock timer to 3.5 seconds. (See Alarm Feature II – 5 Programming.)

H7 Flashing LED. Connect to LED Plug

H8. RS232 C3 SERIAL TWO-WAY DATA PORT CONNECTION:

This connector is to be used for Serial Data communications with I-Datalink modules by Auto Page only! DO NOT CONNECT THIS TO ANY OTHER WIRING!

This connector will transmit digital codes to operate all functions of Autopage data modules. When these modules are used, no other data bus connections need to be made to the RS-603. The Data Bus module will receive its commands directly from the CPU of the RS-603. This will provide greater theft protection as well as aid in the installation of this product. The RS-232 serial harness is provided with all Autopage serial data modules and is not included with the RS-603. This two-way data port has been designed for use with all C I 3 compatible components. C3 Telematics system is available at any authorized Autopage dealer.

This port will only operate correctly with Autopage C3 I-Datalink Modules.

PROGRAMMING

A. PROGRAMMING TRANSMITTER:

Note: This remote start system will only retain the last 4 remote transmitters programmed. If the transmitter memory is exceeded, the security system will start deleting transmitters from memory in chronological order.

PROGRAMMING THE REMOTE TRANSMITTER







1. Turn the Ignition 'switch 'OFF/ON' 3 TIMES and stay in the '**ON**' position. Within 15 seconds.
2. Push the Programming switch **2 times** holding in on the 2nd push, until a long chirp from the horn (optional) and the LED starts to flash then release the valet switch. You are now in the Transmitter programming mode.
3. Press the 'Lock' button on the transmitter until a chirp from the horn / a flash from the parking light / the LED turns on for 2 seconds to confirming the first transmitter is now programmed.
4. Apply the same procedure (step 3) to program 2nd, 3rd and 4th

Exit: Turn Ignition to 'OFF' position, or leave it for 15 seconds. 3 long chirps & 3 parking light flashes will confirm exit.

B. FEATURES PROGRAMMING:

FEATURE "I" PROGRAMMING:

1. Turn the Ignition 'switch 'ON/OFF' 3 TIMES and stay in the 'OFF' position.
2. Push the Programming switch **1 time** and hold it until the LED turns on and (*) **one chirp with a long chirp is heard**; then release the Programming switch. You are now in the feature 'I' programming mode.
3. Press and release the transmitter button with the Icon corresponding to the feature with the icon you want to program.
 - a. The (optional) horn chirps and the LED will flash then pause indicating a previous setting.
 - b. The factory default settings are always [1] LED flash, [1] horn chirp.
4. Depress the transmitter button icon again to change the feature. Simply keep re-depressing the transmitter button icon again until the module advances to your desired setting.
5. Depress the next desired transmitter icon button corresponding to the feature you want to program.

Press Transmitter Button	One Chirp / LED one pulse Factory Default Setting	Two Chirps / LED two pulse	Three Chirps / LED three pulse
1. 	H3/2 White/Blue = 1 Pulse Remote Start	H3/2 White/Blue = 3 Pulse Remote Start	
2. 	H3/8 Pink Wire = Factory Security Disarm Signal Output	H3/8 Pink Wire = Start Status (Shock Sensor Bypass Control) Output	H3/8 Pink Wire = 20 Second Ground out Key Sensor By-pass
3.  + 	H2/4 Brown Wire = Horn Output	H2/4 Brown Wire = Rearm Signal Output	
4.  + 	* <u>Button Two Push Remote</u>	* Button One push Remote Start	
5. 	Without ignition controlled door locks & unlocks	Ignition controlled door locks & unlocks	

(*) **The Horn must be connected to hear the programming chirps.**

Exit: Turn Ignition to the 'ON' position, or leave it for 15 seconds. 3 long chirps & 3 parking light flashes will confirm exit.

FEATURE “II” PROGRAMMING:

- 1 Turn the Ignition 'switch 'ON/OFF' 3 TIMES and stay in the 'OFF' position.
- 2 Push the Programming switch **2 times** and hold it until the LED turns on and (*) **two chirps with a long chirp is heard**; then release the Programming switch. You are now in the feature 'II' programming mode.
- 3 Press and release the desired transmitter button icon corresponding to the feature you want to program.
(*) **The Horn must be connected to hear the programming chirps.**

Press Transmitter Button	One Chirp / LED one pulse Factory Default Setting	Two Chirps / LED two pulse	Three Chirps / LED three pulse	Four Chirps / LED four pulse
1.	Gasoline Engine	Diesel Engine and 10 seconds warn-up timer	Diesel Engine and 15 seconds warn-up timer	Diesel Engine and 20 seconds warn-up timer
2.	20 minutes run time	10 minutes run time	30 minutes run time	5 minutes run time
3. +	H2/2 White wire = Constant Parking Light Output	H2/2 White wire = Flash Parking Light Output		
4. + *	Door Lock before start	Door Lock after start	Door Lock before & after start * <i>This is the preferred setting when using the optional XT-11 single button remote</i>	Without this feature
5. *	0.8-second Door lock & Unlock.	3.5-second Door Lock & Unlock.	0.8 second lock, 0.35 second unlock	0.8 second dbl lock, 0.8 second dbl unlock
	Five chirps= 0.8 second lock, dbl 0.8 second unlock Six chirps= dbl 0.8 second lock, 0.8 second unlock			

Exit: Turn Ignition to the 'ON' position, or leave it for 15 seconds. 3 long chirps & 3 parking light flashes will confirm exit.

FEATURE “III” PROGRAMMING:



1. Turn the Ignition switch 'ON/OFF' 3 TIMES and stay in the 'OFF' position.
2. Push the Programming switch **3 times** and hold it until the LED turns on and (*) **three chirps with a long chirp is heard**; then release the Programming switch. You are now in the feature 'III' programming mode.
4. Press and release the desired transmitter button icon corresponding to the feature you want to program.
(*) **The Horn must be connected to hear the programming chirps.**

Press Transmitter Button	One Chirp / LED one pulse Factory Default Setting	Two Chirps / LED two pulse	Three Chirps / LED three pulse	Four Chirps / LED four pulse
1.	Tachometer checking type.	Voltage checking type	Timer checking type	DBI TACH ** DATA ONLY !!
2.	RPM learning Start Timer: 0.6-second	0.8-second (2 chirps), 1.0-second (3 chirps), 1.2-second (4 chirps), 1.4-second (5 chirps), 1.6-second (6 chirps), 1.8-second (7 chirps), 2.0-second (8 chirps), 3.0-second (9 chirps), 4.0-second (10 chirps),		
3. *	Low check level	Hi check level		
4. +	Second Accessory H3/9 Blue/Black	Second Start H3/9 Blue/Black		
5. +	+ 50 RPM DBI ONLY	No RPM learning		
6. + *	- 50 RPM DBI ONLY	No RPM Learning or < 50RPM		



Exit: Turn Ignition to the 'ON' position, or leave it for 15 seconds. 3 long chirps & 3 parking light flashes will confirm exit.

**** This will be used when connected to an Autopage CI3 compatible Two-way data module that will recognize the tach signal from the vehicle. This signal will need to be learned in the same manner as the analog tachometer wire. If this learned value needs to be adjusted, use steps 7 and 8 of this programming table**

RPM LEARNING

1. Turn the Ignition 'switch 'ON/OFF' 3 TIMES and stay in the 'OFF' position.
2. Push the Programming switch **3 times** and hold it until the LED turns on and **three** chirps with a long chirp is heard; then release the Programming switch. You are now in the feature 'III' programming mode.
3. Press and release the transmitter  button once to set the "Tachometer Checking Type". [1] LED flash, [1] chirp to confirm this setting.
4. Press and release the transmitter  button once; [1] chirp to indicate your are in features "RPM Learning mode".
5. Start the vehicle with the key. (While the engine is running, the parking & LED will flash, If don't, please check tachometer White/Red wire connection. **(H3/1)**)
6. Press and hold the program switch for 2 seconds until a long chirp and the LED light constant for two seconds. The RPM signal is learned.
7. Turn the ignition switch off to exit the program mode. 3 long chirps & 3 parking light flashes will confirm exit.

RETURN TO FACTORY DEFAULT SETTING:

1. Turn the ignition 'ON' then 'OFF' 3 TIMES and stay in the 'OFF' position.
2. Push the Programming switch **10 times** and hold it on the 10th push. When *ten chirps with a long chirp is heard** and the LED turns on; then release the Programming switch. You are now in the "Return To Factory Default Setting" programming mode. ***Optional horn output must be installed to hear the chirps.**
3. Press the  +  buttons on the transmitter together for 6 seconds, there will be a confirmation of six chirps with 3 long chirp and 3 parking light flashes to confirm the system "Feature Programming" have all returned to the factory default settings.

Exit: Turn the ignition switch "on" or leave it for 15 seconds. 3 long chirps & 3 parking light flashes will confirm exit.

TO REMOTE START THE VEHICLE:

1. Press the transmitter ***** button **twice** to start the vehicle.
2. The parking light will activate to indicate the remote start received the signal.
3. It will take approximately 5 seconds for the engine to start.
4. Once the engine is running, after couple seconds the parking light will turn on again and climate controls will activate and adjust the vehicles interior temperature to your preset setting.
5. The vehicle will run for 5 to 30 minute cycle and automatically shut down.

SHUTDOWN DIAGNOSTICS

The unit has the ability to report the cause of the last shutdown of the remote start system.

Enter:

1. Turn the Ignition 'switch to 'ON position.
2. Press the  button on the transmitter.
3. The LED will now report the last system shutdown by flashing for one minute in the following grouped patterns:

LED Flashes	Shutdown Mode

1	(-) Safety Shutdown input (Hood)	1. Close the hood. 2. Check H3/3 White/ Black wire connection.
1	(+) Safety Shutdown input (Brake) or	3. Check H3/5 White/ Violet wire connection.
1	Neutral Safety Switch input fail.	4. Move the Enable Toggle Switch to "ON" position. (If installed.) 5. Move the gear selector to "Park"/ "NEUTRAL" position. 6. Check H3/4 Black/White wire connection.
3	No RPM or Low Voltage.	TACHOMETER CHECKING TYPE: Check H3/1 White/Red wire connection VOLTAGE CHECKING TYPE: Program the "CHECK LEVEL" from "Hi Check Level" to "Low Check Level"
5	Over-rev	
6	System timed out	
7	Transmitter	No transmitter Signal
8	Tach. Signal has not been learned	Re-learning the RPM (Feature III – 2)

TROUBLE SHOOTING

There are 5 reasons why the remote start * button will not respond from the transmitter.

1. The Black/White Neutral Safety wire is not grounded. Must be grounded to start.
2. Hood Pin switch White/Black wire has a ground present. Must not show ground to start.
3. Brake pedal switch White/Violet has 12 volt present. Must not show 12 volt to start.
4. The system is in Valet mode.
5. The remote start feature programming has not been programmed to start the vehicle. The remote start must be programmed how to start the vehicle.

TESTING YOUR INSTALLATION:

Caution!! The following procedure must be performed after the installation of the Remote Start Device. It is the responsibility of the installing technician to complete these tests. Failure to test the unit in the following manner may result in personal injury, property damage, or both.

1. Test the BRAKE shutdown circuit: With the vehicle in park (P), start the vehicle using the remote transmitter, Once the engine is running, press the brake pedal. The vehicle should shut down immediately. If the vehicle continues to run, check the brake circuit WHITE/ VIOLET wire (H3/3) connection.
2. Test the HOOD PIN shutdown circuit: Start the vehicle using the remote transmitter, Once the engine is running, pull the hood release and raise the hood. The vehicle should shut down immediately. If the vehicle continues to run, check the hood pin WHITE/ BLACK wire (H3/4) connection.

3. NEUTRAL START SAFETY TEST:

1. Set the vehicle parking brake.
2. Block the drive wheels to prevent vehicle movement.
3. Sitting in the vehicle, turn the ignition switch to "ON" or "RUN" position. But do not start the engine.
4. Step on the brake pedal and shift the gear selector into "DRIVE" (D).
5. Put your foot over the brake pedal but do not press down on it. Be ready to step on the brake to shut down the Remote Start Device.
6. Start the vehicle using remote transmitter.
 - a. If the starter does not engage, the test is complete.
 - b. If the starter engages, immediately step on the brake pedal to shut down the system, recheck your VIOLET wire (H1/1 starter output wire) connection. The heavy gauge VIOLET wire must be connected to the ignition switch side of the Neutral Start Switch. If the vehicle you are working on does not have an Electrical Neutral Safety Switch, it will be necessary to reconfigure the Remote Starts Wiring to accommodate this vehicle. The information concerning the Mechanical Neutral Safety Switch provided below will help you to determine if the vehicle you are working on has this type of safety switch and will provide alternate wiring methods to accommodate this situation.

MECHANICAL NEUTRAL SAFETY SWITCH CONSIDERATIONS:

Mechanical neutral safety switch configurations differ slightly in that they do not offer the same level of safety when installing a remote start device. Often when the ignition switch is turned off while the gear selector is in any position other

than park or neutral, the mechanical function will not allow the key to be turned to the start position or be removed from the ignition cylinder. This configuration prevents mechanical operation while the vehicle is in gear but offers no consideration for electrical operation. Because of this potential problem, this installation requires the additional connection of a safety wire from the remote start device to the vehicle PARK/NEUTRAL ECM input or the vehicle key in sensor. This connection will prevent remote start operation if the key is left in the ignition switch regardless of the gear selector position.

PARK/NEUTRAL ECM INPUT:

The Park/Neutral ECM input is the preferred method of installation. This not only maintains the integrity of the factory circuit, it is also the easiest to install, providing the vehicle you are working on has this ECM input.

The installation required for this application (shown below), indicates in the slight reconfiguration of the control switch wiring. Shown is a typical GM Park/Neutral ECM input circuit. To connect the Remote Start unit to the GM Park/Neutral ECM input:

1. Locate the Orange/Black reference wire in the "C2" connector found at the ECM in GM B Body vehicles or, locate the equivalent reference wire in the vehicle you are installing the Remote Start Unit in.
2. Connect the BLACK/WHITE Neutral Safety Switch wire (H3/4) to this reference wire.

NOTE: If the optional remote starts enable toggle switch is installed, connect the one side the enable switch to this reference wire and connect the other side of the enable switch to the BLACK/WHITE Neutral Safety Switch wire (H3/2) of the Remote Start unit.

The reference diagram below shows a typical GM B Body ECM reference wire and how it is to be connected to the Remote Start Unit.

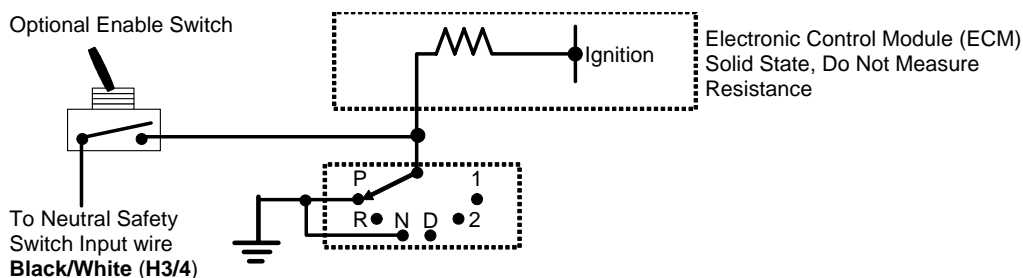

KEY-IN SENSOR CIRCUITS:

If the vehicle you are working on does not have or you cannot locate the ECM reference wire, there are two alternatives available. Although not preferred, the vehicle Key In Sensor may be reconfigured to allow a margin of safety and will prevent the vehicle with a Mechanical Neutral Start Switch from starting in gear.

WE ADVISE THAT YOU MAINTAIN THE FACTORY CIRCUIT WHENEVER POSSIBLE. The following two circuits may be used only if the above circuit is not available.

NOTE: When completing an installation using either of the following key in sensor circuits, if the operator inserts the ignition key while the vehicle is running under the control of the Remote Start, the vehicle will shut down. This must be explained to the operator as it is in contrast to the normal operation of a vehicle utilizing an electrical neutral start switch and is inconsistent with the operators' manual.

Additional information concerning Key in Sensor methods 1&2 are listed below and should be reviewed before considering either alternative.

Method 1 will allow the safety required for the remote start unit and prevent the vehicle from starting while in any gear other than Park or Neutral while the key is in the ignition cylinder however, if the key is left in the ignition switch and the door is left opened, the added relay will be energized causing a 150mA drain on the battery.

Method 2 will allow the safety required for the remote start unit and prevent the vehicle from starting while in any gear other than Park or Neutral while the key is in the ignition cylinder however, the original factory key in chime module will not alert the owner that the key has been left in the ignition switch. In addition, this may also affect other warning tones such as the light 'on' reminder.

These situations should be carefully considered before altering the vehicle's wiring and must be fully explained to the consumer.

METHOD 1

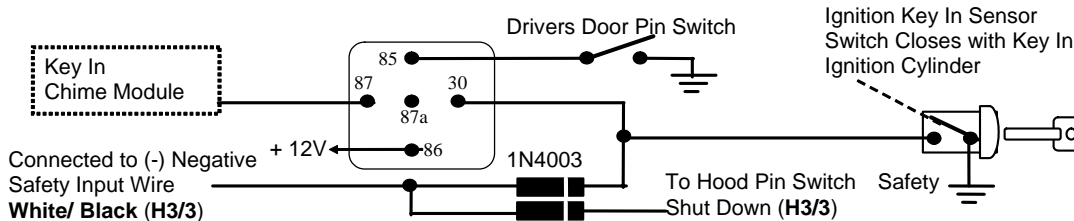

To connect to the key in sensor as shown in method 1:

- A. Locate the control wire that connects the driver's door pin switch to the key in sensor switch.
- B. Cut this wire and connect the ignition cylinder side to chassis ground.
- C. Locate the key in sensor switch wire that connects the chime module to the ignition cylinder.
- D. Cut this wire and connect the ignition cylinder side to terminal 30 of a P&B VF45F11 or equivalent relay.
- E. Connect the cathode (striped) side of a 4003 series diode to this same wire, and connect the (non striped) side to the negative safely input wire (WHITE/ BLACK) (H3/4) of the Remote Start Unit.
- F. Connect terminal 86 of the relay to a fused + 12 volt constant battery source.
- G. Connect terminal 87 of the relay to the Chime Module side of the previously cut wire in step D.
- H. Connect terminal 85 of the relay to the Drivers Door side of the pin switch wire previously cut in step B.

Note: A second 4003 series diode may be required to maintain the integrity of the hood open, shut down circuit. If this is the case, it must be installed as shown in the diagram above. The anode (Non Stripped) side must be connected to the WHITE/ BLACK wire (H3/3) of the Remote Start Unit. The cathode (Striped) side must be connected to the hood pin switch.

METHOD 2

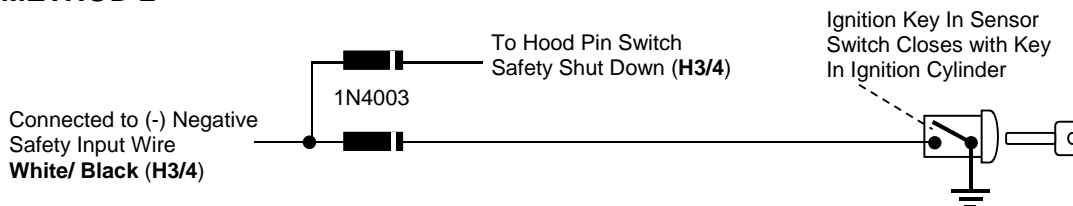

To connect to the key in sensor circuit as shown for method 2:

- A. Locate the control wire that connects the drivers door pin switch to the key in sensor switch.
- B. Cut this wire and connect the ignition cylinder side to chassis ground.
- C. Locate the key in sensor switch wire that connects the chime module to the ignition cylinder.
- D. Cut this wire and connect the ignition cylinder side to the Remote Start Negative Safety Shut down wire WHITE/ BLACK (H3/4), using a 4003 series diode as shown above.

Note: A second 4003 series diode may be required to maintain the integrity of the hood open, shut down circuit. If this is the case, it must be installed as shown in the diagram above. The anode (Non Stripped) side must be connected to the WHITE/ BLACK wire (H6/4) of the Remote Start Unit. The cathode (Striped) side must be connected to the hood pin switch.

AFTER THE CONNECTION OF THE NEUTRAL START SAFETY WIRE AS INDICATED IN ANY OF THE PREVIOUS ALTERNATE CONFIGURATIONS, THIS CIRCUIT MUST BE TESTED FOR OPERATION.

Retest by following the steps outlined in the NEUTRAL START SAFETY TEST shown in this manual.

C|3™

2-WAY COMMUNICATION TO THE POWER OF 3

THE NEXT REVOLUTION

COMMUNICATE WITH YOUR VEHICLE
VIA YOUR CELLPHONE WITHOUT USING
MINUTES OR ADDING EXTRA SERVICES



Security
Instant Notification



Remote Start
Pre-Warm | Pre-Cool



GPS Tracking
Via Cell or Internet

Exclusively from
AUTOPAGE ((|))

www.autopageusa.com

Patent Pending-C|3 is a trademark of Auto Page, Inc., Torrance, CA

It is recommended to have a minimal digital service plan on your cell phone

Your RS-603 is C|3 compatible and will open your world to the true power of two way communication. Complete tracking and full cell phone functionality can be added to your system. For more information please visit your local authorized Autopage dealer or go to www.autopageusa.com.



Winner of the BEST OF INNOVATIONS
2008 CES



BLANK



**Auto Page, Inc.
960 Knox Unit #B
Torrance, CA 90502
www.autopageusa.com**

**Toll Free Tech Support Hotline: 800-945-2527
(For certified installation technicians only)**