



# Transmitter

ZM-520PA/ZM-521PA  
ZM-530PA/ZM-531PA

If you have any comments or suggestions on this  
manual, please contact us at:  
[www.nihonkohden.com](http://www.nihonkohden.com)

0614-904743



### **Copyright Notice**

The entire contents of this manual are copyrighted by Nihon Kohden. All rights are reserved. No part of this document may be reproduced, stored, or transmitted in any form or by any means (electronic, mechanical, photocopied, recorded, or otherwise) without the prior written permission of Nihon Kohden.



# Contents

GENERAL HANDLING PRECAUTIONS .....	i
WARRANTY POLICY .....	iii
Equipment Authorization Requirement .....	iv
EMC RELATED CAUTION.....	v
Conventions Used in this Manual and Instrument .....	vii
Warnings, Cautions and Notes.....	vii
Explanations of the Symbols in this Manual and Instrument.....	viii
Intended Use .....	1
General .....	1
Receiving Monitor .....	3
Panel Description .....	4
Top Panel .....	4
Front Panel.....	5
Rear Panel .....	7
Important Safety Information .....	8
General .....	8
Output Signal .....	12
Battery .....	12
Transmitter Channel Management.....	13
For Patients Using Implantable Pacemaker .....	13
ECG Monitoring .....	14
SpO <sub>2</sub> Monitoring.....	15
Maintenance .....	17
Preparation on Transmitter .....	19
Batteries.....	19
Handling Batteries.....	19
Battery Lifetime .....	19
Installing (Replacing) Batteries .....	20
Situations Requiring Battery Replacement .....	21
Battery Level Indication.....	21
Attaching a Strap to the Transmitter.....	22
Turning On the Transmitter.....	23
Check Items Before Use .....	23
Check Items After Power On .....	24
Check Items After Use .....	24
Turning Off the Transmitter.....	25
Changing the Transmitter Channel.....	25
Changing Parameter and System Setup Settings .....	26
Changing PARAMETER SETUP Settings.....	26



Parameter Setup Setting List .....	26
Displaying the PARAMETER SETUP Screen .....	27
Changing Parameter Setup Settings.....	28
Changing SYSTEM SETUP Settings.....	31
System Setup Setting List.....	31
Displaying the SYSTEM SETUP Screen.....	32
Changing System Setup Settings .....	33
Initializing Settings .....	36
Attaching Electrodes and SpO <sub>2</sub> Probe to the Patient.....	37
Attaching Electrodes .....	37
Selecting Electrode Lead .....	37
Connecting the Electrode Lead to the Transmitter .....	38
Electrode Position .....	39
Attaching Electrodes to the Patient and Connecting the Electrode Leads to Disposable Electrodes .....	43
Checking ECG on the Transmitter Screen.....	44
Attaching the SpO <sub>2</sub> Probe.....	44
Selecting the SpO <sub>2</sub> Probe .....	44
Connecting the SpO <sub>2</sub> Probe to the Transmitter .....	47
Attaching the Probe to the Patient.....	48
Locking the Keys on the Transmitter .....	50
Monitoring.....	51
Screen Descriptions.....	51
Check Electrodes Screen.....	53
Numeric and Waveform Screen .....	54
Waveform Review Screen .....	55
Numeric Review Screen.....	56
Display Off.....	56
Basic Monitoring Operation .....	57
Using the Function Key .....	57
Suspending Alarms on the Receiving Monitor .....	58
Pause Monitoring .....	59
Resume Monitoring after Pause.....	61
Confirming Patient.....	61
Turning the Display Off.....	62
Turning the Display On after It was Turned Off.....	62
ECG and Respiration Monitoring.....	63
Turning ECG Measurement On/Off .....	66
Turning Respiration Measurement On/Off.....	66
Electrode Detachment.....	66
SpO <sub>2</sub> Monitoring.....	67
Indications and Messages .....	71



Indication .....	71
Messages .....	71
Message Display Priority .....	74
Troubleshooting .....	75
Transmitter .....	75
ECG/Respiration .....	76
SpO <sub>2</sub> .....	77
Maintenance .....	78
1. External Check .....	78
2. Transmitter Channel .....	78
3. Transmitting/Receiving Signal .....	79
4. Display .....	79
5. Key Operation .....	81
6. ECG Check .....	82
7. Respiration Check .....	83
8. SpO <sub>2</sub> Check .....	83
Maintenance Check Sheet .....	85
Lifetime and Disposal .....	86
Disposing of Used Batteries .....	86
Battery Lifetime .....	86
Disposal .....	86
Disposing of Electrodes and SpO <sub>2</sub> Probes .....	86
Disposing of Transmitter .....	86
Cleaning, Disinfection and Sterilization .....	87
Transmitter and Electrode Leads .....	87
Cleaning .....	87
Disinfection .....	87
SpO <sub>2</sub> Probe .....	88
Periodic Replacement Schedule .....	88
Repair Parts Availability Policy .....	88
Specifications .....	89
ZM-520PA/530PA .....	89
Measuring Parameters .....	89
Transmitting Data .....	89
Display .....	89
Displayed Data .....	89
ECG .....	89
Respiration Measurement .....	91
SpO <sub>2</sub> Measurement (ISO 9919: 2005 compliance) .....	91
Transmitter .....	93
Power Requirements .....	93
Dimension and Weight .....	94

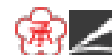

Environment .....	94
Safety Standards.....	94
Electromagnetic Compatibility.....	95
Electromagnetic Emissions .....	95
Electromagnetic Immunity.....	96
Recommended Separation Distances between Portable and Mobile RF Communications Equipment .....	98
Recovery Time after Defibrillation .....	98
System Composition for EMC Test.....	98
ZM-521PA/531PA.....	99
Measuring Parameters.....	99
Transmitting Data .....	99
Display.....	99
Displayed Data .....	99
ECG .....	99
Respiration Measurement.....	101
SpO <sub>2</sub> Measurement (ISO 9919: 2005 compliance) .....	101
Transmitter .....	103
Power Requirements.....	103
Dimension and Weight .....	104
Environment .....	104
Safety Standards.....	104
Electromagnetic Compatibility.....	105
Electromagnetic Emissions .....	105
Electromagnetic Immunity.....	106
Recommended Separation Distances between Portable and Mobile RF Communications Equipment .....	108
Recovery Time after Defibrillation .....	108
System Composition for EMC Test.....	108
Standard Accessories.....	109
Options .....	110
Transmitter .....	110
ECG/RESP.....	110
SpO <sub>2</sub> .....	111
Transmission Frequencies .....	112

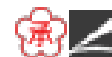

## GENERAL HANDLING PRECAUTIONS

This device is intended for use only by qualified medical personnel. Use only Nihon Kohden approved products with this device. Use of non-approved products or in a non-approved manner may affect the performance specifications of the device. This includes, but is not limited to, batteries, recording paper, pens, extension cables, electrode leads, input boxes and AC power.

**Please read these precautions thoroughly before attempting to operate the instrument.**

- 1. To safely and effectively use the instrument, its operation must be fully understood.**
- 2. When installing or storing the instrument, take the following precautions:**
  - (1) Avoid moisture or contact with water, extreme atmospheric pressure, excessive humidity and temperatures, poorly ventilated areas, and dust, saline or sulphuric air.
  - (2) Place the instrument on an even, level floor. Avoid vibration and mechanical shock, even during transport.
  - (3) Avoid placing in an area where chemicals are stored or where there is danger of gas leakage.
  - (4) The power line source to be applied to the instrument must correspond in frequency and voltage to product specifications, and have sufficient current capacity.
  - (5) Choose a room where a proper grounding facility is available.
- 3. Before Operation**
  - (1) Check that the instrument is in perfect operating order.
  - (2) Check that the instrument is grounded properly.
  - (3) Check that all cords are connected properly.
  - (4) Pay extra attention when the instrument is in combination with other instruments to avoid misdiagnosis or other problems.
  - (5) All circuitry used for direct patient connection must be doubly checked.
  - (6) Check that battery level is acceptable and battery condition is good when using battery-operated models.
- 4. During Operation**
  - (1) Both the instrument and the patient must receive continual, careful attention.
  - (2) Turn power off or remove electrodes and/or transducers when necessary to assure the patient's safety.
  - (3) Avoid direct contact between the instrument housing and the patient.

**5. To Shutdown After Use**

- (1) Turn power off with all controls returned to their original positions.
- (2) Remove the cords gently; do not use force to remove them.
- (3) Clean the instrument together with all accessories for their next use.

**6. The instrument must receive expert, professional attention for maintenance and repairs. When the instrument is not functioning properly, it should be clearly marked to avoid operation while it is out of order.****7. The instrument must not be altered or modified in any way.****8. Maintenance and Inspection:**

- (1) The instrument and parts must undergo regular maintenance inspection at least every 6 months.
- (2) If stored for extended periods without being used, make sure prior to operation that the instrument is in perfect operating condition.
- (3) Technical information such as parts list, descriptions, calibration instructions or other information is available for qualified user technical personnel upon request from your Nihon Kohden representative.

**9. When the instrument is used with an electrosurgical instrument, pay careful attention to the application and/or location of electrodes and/or transducers to avoid possible burn to the patient.****10. When the instrument is used with a defibrillator, make sure that the instrument is protected against defibrillator discharge. If not, remove patient cables and/or transducers from the instrument to avoid possible damage.**





## WARRANTY POLICY

Nihon Kohden Corporation (NKC) shall warrant its products against all defects in materials and workmanship for one year from the date of delivery. However, consumable materials such as recording paper, ink, stylus and battery are excluded from the warranty.

NKC or its authorized agents will repair or replace any products which prove to be defective during the warranty period, provided these products are used as prescribed by the operating instructions given in the operator's and service manuals.

No other party is authorized to make any warranty or assume liability for NKC's products. NKC will not recognize any other warranty, either implied or in writing. In addition, service, technical modification or any other product change performed by someone other than NKC or its authorized agents without prior consent of NKC may be cause for voiding this warranty.

Defective products or parts must be returned to NKC or its authorized agents, along with an explanation of the failure. Shipping costs must be pre-paid.

This warranty does not apply to products that have been modified, disassembled, reinstalled or repaired without Nihon Kohden approval or which have been subjected to neglect or accident, damage due to accident, fire, lightning, vandalism, water or other casualty, improper installation or application, or on which the original identification marks have been removed.

In the USA and Canada other warranty policies may apply.

### CAUTION

United States law restricts this product to sale by or on the order of a physician.



## Equipment Authorization Requirement

This device complies with Part 15 of the FCC (Federal Communications Commission) Rules. Operation is subject to the following two conditions:

- (1) this device may not cause harmful interference, and
- (2) this device must accept any interference received, including interference that may cause undesired operation.

This device complies with Part 95 Subpart H of the FCC Rules to be used in wireless medical telemetry service.

Operation of this equipment requires the prior coordination with a frequency coordinator designated by FCC for the Wireless Medical Telemetry Service.

### CAUTION

To comply with the FCC radio frequency (RF) exposure compliance requirements, no change to the antenna or the device is permitted. Any change to the antenna or the device could result in the device, exceeding the RF exposure requirements and void user's authority to operate this device.

### NOTE

- Use this device only indoors.
- This device has been tested and complies with FCC radiation exposure limits set forth for an uncontrolled environment. The RF transmission power from the antenna conforms to the general public FCC RF Exposure Guidelines in Supplement C to OET65 limit of Specific Absorption Rate (SAR) 1.6 W/kg. The maximum SAR value measured from this device was extremely smaller than 1.6 W/kg. This device must not be located together with or operated in conjunction with any other unspecified antenna or transmitter.
- The devices require registration and deployment by an authorized frequency coordinator. The ASHE (American Society for Healthcare Engineering) has been designated by the FCC to manage the WMTS frequencies. This device has frequency bands which may not be used in some areas. For details, contact your Nihon Kohden representative. For details on the guidelines, refer to the ASHE home page.

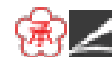

### EMC RELATED CAUTION

This equipment and/or system complies with the International Standard IEC 60601-1-2 for electromagnetic compatibility for medical electrical equipment and/or system. However, an electromagnetic environment that exceeds the limits or levels stipulated in the IEC 60601-1-2, can cause harmful interference to the equipment and/or system or cause the equipment and/or system to fail to perform its intended function or degrade its intended performance. Therefore, during the operation of the equipment and/or system, if there is any undesired deviation from its intended operational performance, you must avoid, identify and resolve the adverse electromagnetic effect before continuing to use the equipment and/or system.

The following describes some common interference sources and remedial actions:

1. Strong electromagnetic interference from a nearby emitter source such as an authorized radio station or cellular phone:  
Install the equipment and/or system at another location if it is interfered with by an emitter source such as an authorized radio station. Keep the emitter source such as cellular phone away from the equipment and/or system.
2. Effect of direct or indirect electrostatic discharge:  
Make sure all users and patients in contact with the equipment and/or system are free from direct or indirect electrostatic energy before using it.
3. Electromagnetic interference with any radio wave receiver such as radio or television:  
If the equipment and/or system interferes with any radio wave receiver, locate the equipment and/or system as far as possible from the radio wave receiver.
4. Electromagnetic interference with any radio wave receiver such as radio or television:  
If the equipment and/or system interferes with any radio wave receiver, locate the equipment and/or system as far as possible from the radio wave receiver.
5. Interference of lightning:  
When lightning occurs near the location where the equipment and/or system is installed, it may induce an excessive voltage in the equipment and/or system. In such a case, disconnect the AC power cord from the equipment and/or system and operate the equipment and/or system by battery power, or use an uninterruptible power supply.



6. Use with other equipment:

When the equipment and/or system is adjacent to or stacked with other equipment, the equipment and/or system may affect the other equipment. Before use, check that the equipment and/or system operates normally with the other equipment.

7. Use of unspecified accessory, transducer and/or cable:

When an unspecified accessory, transducer and/or cable is connected to this equipment and/or system, it may cause increased electromagnetic emission or decreased electromagnetic immunity. The specified configuration of this equipment and/or system complies with the electromagnetic requirements with the specified configuration. Only use this equipment and/or system with the specified configuration.

8. Use of unspecified configuration:

When the equipment and/or system is used with the unspecified system configuration different than the configuration of EMC testing, it may cause increased electromagnetic emission or decreased electromagnetic immunity. Only use this equipment and/or system with the specified configuration.

9. Measurement with excessive sensitivity:

The equipment and/or system is designed to measure bioelectrical signals with a specified sensitivity. If the equipment and/or system is used with excessive sensitivity, artifact may appear by electromagnetic interference and this may cause mis-diagnosis. When unexpected artifact appears, inspect the surrounding electromagnetic conditions and remove this artifact source.

If the above suggested remedial actions do not solve the problem, consult your Nihon Kohden representative for additional suggestions.



## Conventions Used in this Manual and Instrument

### Warnings, Cautions and Notes

Warnings, cautions and notes are used in this manual to alert or signal the reader to specific information.

#### **WARNING**

A warning alerts the user to the possible injury or death associated with the use or misuse of the instrument.

#### **CAUTION**

A caution alerts the user to possible injury or problems with the instrument associated with its use or misuse such as instrument malfunction, instrument failure, damage to the instrument, or damage to other property.

#### **NOTE**

A note provides specific information, in the form of recommendations, prerequisites, alternative methods or supplemental information.



## Explanations of the Symbols in this Manual and Instrument

The following symbols found in this manual/instrument bear the respective descriptions as given.

### On Panel

Symbol	Description	Symbol	Description
	Change screen		Defibrillation proof type BF applied part
	Attention, consult operator's manual		Defibrillation proof type CF applied part
	Moves cursor, scrolls data		Serial number
	Direction for attaching battery cover		Date of manufacture
	Direction for inserting battery		RF transmitter Non-ionizing radiation
	Direct current		cCSAus mark
	Call key		

### On LCD

Symbol	Description	Symbol	Description
	Batteries are fully charged		Batteries are almost empty Replace battery
	Batteries are getting low		Alarm suspended
	Batteries are low		QRS/pulse sync mark

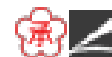

## Intended Use

### General

The ZM-520PA and ZM-521PA transmitter transmits ECG and respiration from a patient to a Nihon Kohden monitor for continuous monitoring. The front LCD displays ECG, numeric values of monitoring parameters, messages and battery condition.\* It also displays the compressed waveform and numeric data of the latest 10 minutes.

The ZM-530PA and ZM-531PA transmitter transmits ECG, respiration and pulse waveforms and SpO<sub>2</sub> from a patient to a Nihon Kohden monitor for continuous monitoring. The front LCD displays ECG (or pulse wave), numeric values of monitoring parameters, messages and battery condition.\* It also displays the compressed waveform and numeric data of the latest 10 minutes.

\* Essential performance of this transmitter.

The difference between the ZM-520PA/530PA and ZM-521PA/531PA is the transmission frequency range.

ZM-520PA/530PA: 608.0250 MHz (channel number 9002) to 613.9750 MHz (channel number 9478)

ZM-521PA/531PA: 1395.0250 MHz (channel number E002) to 1399.9750 MHz (channel number E398)  
1427.0250 MHz (channel number E502) to 1431.9750 MHz (channel number E898)

The transmitter channel can be changed with a QI-901PK channel writer.

Read the operator's manual for the receiving monitor together with this manual before use.

#### WARNING

Do not diagnose a patient based only on data acquired by the transmitter. Overall judgement must be performed by a physician who understands the features, limitations and characteristics of the transmitter and by reading the biomedical signals acquired by other instruments.

#### WARNING

Do not use the same transmitter for more than one patient at the same time. Do not connect different sensors from different patients to the same transmitter.



### CAUTION

- Do not use the same channel for different patients. If the same channel is used for two patients, the two patients' data will be lost due to mutual modulation interference, or another patient's data may appear on the receiving monitor screen.
- Do not use two transmitters with adjacent channels in the same hospital. If transmitters with adjacent channels are used, their radio waves interfere with each other.

### CAUTION

Signal loss and artifact may occur because of the multipath cancellation\* when using a transmitter.

\* Multipath Cancellation (Standing Wave Interference):

When a radio wave reflects off a surface, there may be some points in the room where the reflected and direct waves are exactly out of phase. At these points in the room, the reflected and direct waves cancel each other out so that the signal strength is decreased. Locations where signal loss occurs are called "null spots". If the transmitter is moving or nearby people or objects are moving, null spots can occur anytime and anywhere.

### NOTE

- To prevent interference between channels, assign a channel administrator in the hospital and only he or she should manage channel assignment.
- Use Nihon Kohden parts and accessories to assure maximum performance from your instrument.
- For stable signal reception, it is recommended to use a diversity antenna system on the receiving monitor. Otherwise, spike noise from transient fading of electric field strength (for example, people moving) may interfere with the transmitter signal and may be mistaken as an arrhythmia on the receiving monitor.
- For details on antennas and antenna construction, contact your Nihon Kohden representative. You can also refer to the Telemetry System Installation Guide.





## Receiving Monitor

Any Nihon Kohden receiving monitor (central monitor with multiple patient receiver) can receive signals from this transmitter as long as the protocol version and channel setting are the same on the receiving monitor and transmitter.

### NOTE

- For details on the receiving monitor and upgrade information, contact your Nihon Kohden representative.
- The transmitter does not give any alarm other than a “no battery” alarm. Alarms must be managed on the receiving monitor.
- To use protocol 51, the ORG-9100A/ORG-9110A multiple patient receiver software version 03-03 or later is required. For the protocol setting, refer to the “Changing SYSTEM SETUP Settings” section.



## Panel Description

### Top Panel

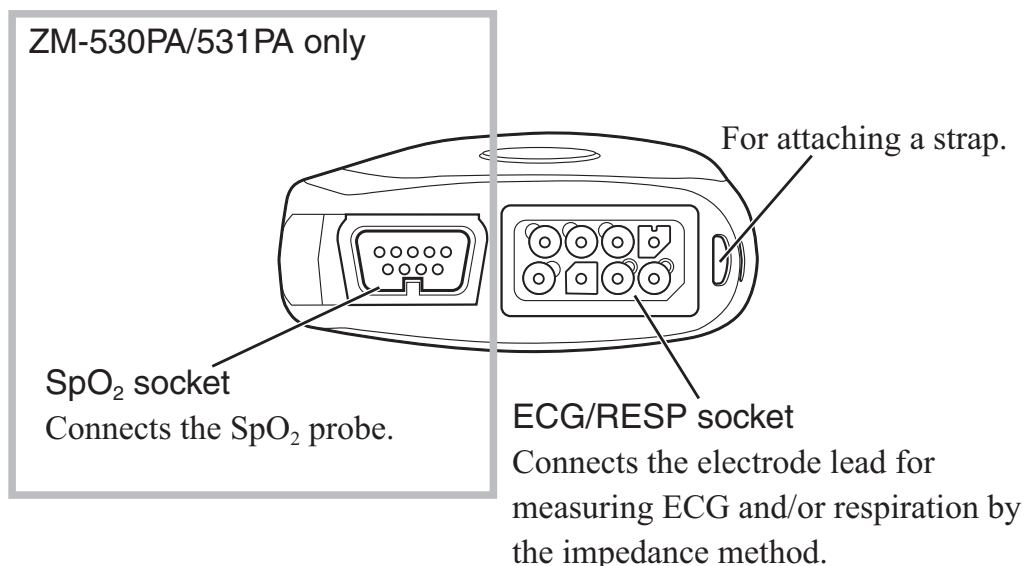

#### WARNING

Before defibrillation, all persons must keep clear of the bed and must not touch the patient or any equipment or cord connected to the patient. Failure to follow this warning may cause electrical shock or injury.

#### WARNING

When performing defibrillation, discharge as far as possible from electrodes, patches and any gel, cream or medicine on the chest of the patient. If there is a possibility that the defibrillator paddle could touch these materials, remove them from the patient. If the defibrillator paddle directly contacts these materials, the discharged energy may cause skin burn to the patient.

#### WARNING

When the transmitter is used with an electrosurgical unit (ESU), firmly attach the entire area of the ESU return plate. Otherwise, the current from the ESU flows into the electrodes of the transmitter, causing electrical burn where the electrodes are attached. For details, refer to the ESU manual.

#### CAUTION

Do not shake or swing the transmitter while holding the leads or cables connected to the transmitter. The transmitter may come off and injure someone or damage surrounding instruments.



## Front Panel

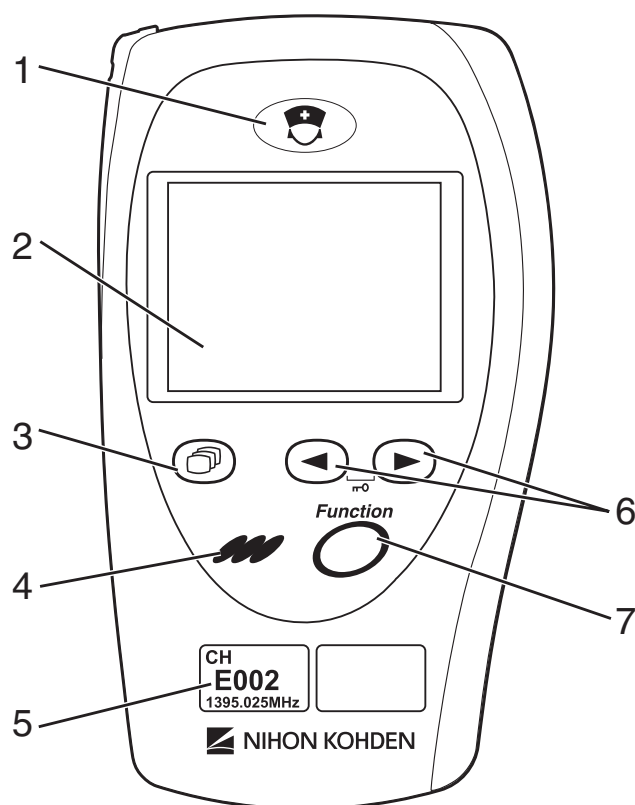

<b>No.</b>	<b>Name</b>	<b>Description</b>
1	CALL key	When this key is pressed, a “peep” sounds at the transmitter, and “CALL” message appears at the monitor. Depending on the settings on the monitor, an ECG waveform is recorded when this key is pressed.
2	LCD	Displays numeric values, ECG or pulse wave, messages and battery status. For details, refer to the “Screen Descriptions” section.
3	Screen key	Toggles the screen in the following order.  After power on: Start up → Check electrodes → Numeric and waveform → Waveform review → Numeric review → Display off → Check electrodes ...  After auto display off: Numeric and waveform → Waveform review → Numeric review → Display off → Check electrodes → Numeric and waveform ...  On a SETUP or CHECK screen, this key cancels changing setting or exits the screen.

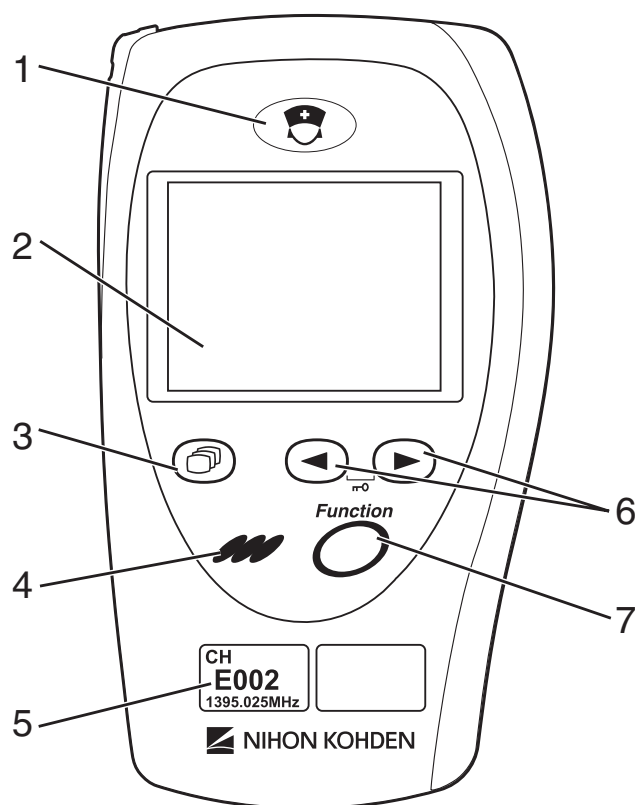

<b>No.</b>	<b>Name</b>	<b>Description</b>
4	Infrared receiver	Used for upgrading the transmitter software.
5	Channel number label	Indicates the channel number of the transmitter.
6	Lead/Scroll keys	On the numeric and waveform screen, these keys change the ECG lead.  On the waveform review screen, these keys scroll data.  On a SETUP screen, these keys move the cursor.
7	Function key	Depending on the setting on the transmitter, this key suspends alarms, pauses monitoring on the receiving monitor or transmits "Patient confirmed" message.  On a SETUP screen, this key registers the selected setting and moves the cursor to the next setting item.  On a CHECK screen, this key starts or stops the maintenance test.



## Rear Panel

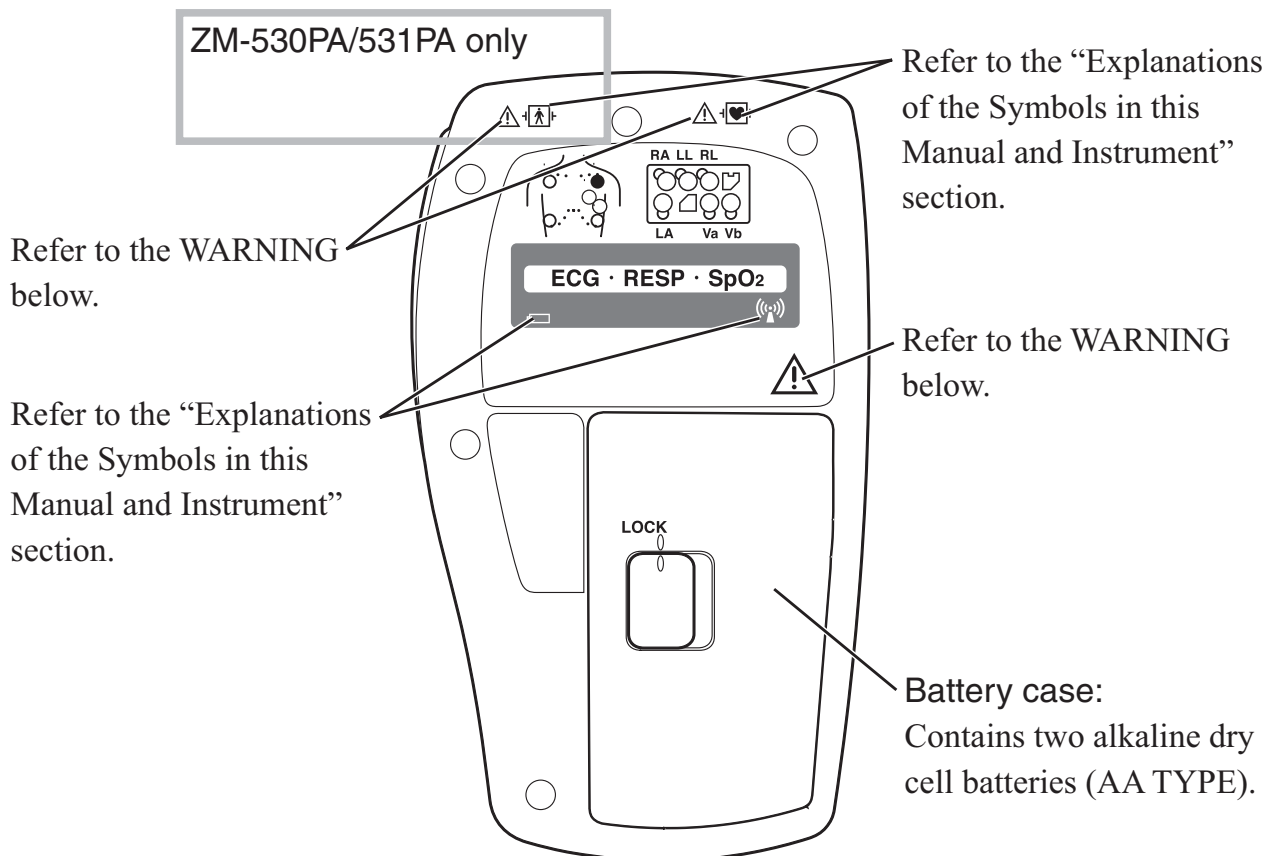

### WARNING

Close the battery case cover during operation. If the transmitter is used with the battery case cover open, anyone who touches the opened battery case may receive an electrical shock when defibrillation is performed. Touching the opened battery case may cause electrostatic discharge and intermittently interfere with the waveform or data.

### WARNING

This transmitter is not waterproof. If detergent or liquid spills into the transmitter, stop using it and contact your Nihon Kohden representative. If a wet transmitter is used, the patient or operator may receive an electrical shock or injury.

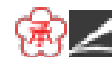

## Important Safety Information

### General

#### WARNING

Never use the transmitter in the presence of any flammable anesthetic gas or high concentration oxygen atmosphere. Failure to follow this warning may cause explosion or fire.

#### WARNING

Never use the transmitter in a hyperbaric oxygen chamber. Failure to follow this warning may cause explosion or fire.

#### WARNING

Do not take this transmitter into the MRI test room. This transmitter is not designed to be used during MRI tests.

#### WARNING

When performing MRI test, remove all electrodes and probe from the patient which are connected to this transmitter. Failure to follow this warning may cause skin burn on the patient. For details, refer to the MRI manual.

#### WARNING

Before defibrillation, all persons must keep clear of the bed and must not touch the patient or any equipment or cord connected to the patient. Failure to follow this warning may cause electrical shock or injury.

#### WARNING

When performing defibrillation, discharge as far as possible from electrodes, patches and any gel, cream or medicine on the chest of the patient. If there is a possibility that the defibrillator paddle could touch these materials, remove them from the patient. If the defibrillator paddle directly contacts these materials, the discharged energy may cause skin burn to the patient.

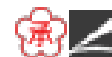
**WARNING**

When the transmitter is used with an electrosurgical unit (ESU), firmly attach the entire area of the ESU return plate. Otherwise, the current from the ESU flows into the electrodes of the transmitter, causing electrical burn where the electrodes are attached. For details, refer to the ESU manual.

**WARNING**

This transmitter is not waterproof. If detergent or liquid spills into the transmitter, stop using it and contact your Nihon Kohden representative. If a wet transmitter is used, the patient or operator may receive an electrical shock or injury.

**WARNING**

Close the battery case cover during operation. If the transmitter is used with the battery case cover open, anyone who touches the opened battery case may receive an electrical shock when defibrillation is performed. Touching the opened battery case may cause electrostatic discharge and intermittently interfere with the waveform or data.

**WARNING**

Do not use the same transmitter for more than one patient at the same time. Do not connect different sensors from different patients to the same transmitter.

**WARNING**

When the signal is unstable, keep the patient under close observation. When the signal is unstable, the monitoring and alarm are not reliable and the receiving monitor cannot detect a sudden change of the patient's condition. This may cause critical changes in the patient condition to be overlooked. Install an appropriate antenna system to ensure stable signal condition.

**WARNING**

Do not diagnose a patient based only on data acquired by the transmitter. Overall judgement must be performed by a physician who understands the features, limitations and characteristics of the transmitter and by reading the biomedical signals acquired by other instruments.

**CAUTION**

Only use Nihon Kohden specified electrodes, electrode leads and SpO<sub>2</sub> probes. Otherwise, the maximum performance from the transmitter cannot be guaranteed.

**CAUTION**

Do not reuse disposable parts and accessories.

**CAUTION**

The measurement values and displayed waveforms on the transmitter and receiving monitor may be different due to timing delay of the display or difference in detection settings.

**CAUTION**

Do not shake or swing the transmitter while holding the leads or cables connected to the transmitter. The transmitter may come off and injure someone or damage surrounding instruments.



**CAUTION**

Signal loss and artifact may occur because of the multipath cancellation\* when using a transmitter.

\* Multipath Cancellation (Standing Wave Interference):

When a radio wave reflects off a surface, there may be some points in the room where the reflected and direct waves are exactly out of phase. At these points in the room, the reflected and direct waves cancel each other out so that the signal strength is decreased. Locations where signal loss occurs are called “null spots”. If the transmitter is moving or nearby people or objects are moving, null spots can occur anytime and anywhere.

**CAUTION**

Turn off the power of mobile phones, small wireless devices and other devices which produce strong electromagnetic interference around a patient (except for devices allowed by the hospital administrator). Radio waves from devices such as mobile phones or small wireless devices may be mistaken as pulse waves or respiration waves and the displayed data may be incorrect.

**CAUTION**

- Do not use the same channel for different patients. If the same channel is used for two patients, the two patients' data will be lost due to mutual modulation interference, or another patient's data may appear on the receiving monitor screen.
- Do not use two transmitters with adjacent channels in the same hospital. If transmitters with adjacent channels are used, their radio waves interfere with each other.



## Output Signal

### WARNING

Do not use the output signal from the receiving monitor as the synchronization signal for other equipment such as IABP, MRI, echocardiography or defibrillator. There may be time delay between the monitor and the other equipment caused by waveform transmission delay and spike noise may interfere on the output signal and be mistaken as a trigger.

## Battery

### WARNING

Do not use NiMH batteries for this transmitter. Some operating environments may cause NiMH batteries to produce gas and explode.

### CAUTION

Battery replacement must be performed by the operator. When replacing the batteries of a transmitter that is currently used for a patient, disconnect the electrode leads from the transmitter before replacing batteries or do not touch the patient during replacement.

### CAUTION

When the transmitter is not in use, remove the batteries. When the batteries are installed, battery power is consumed even when measurement is not performed.

### CAUTION

Do not handle the batteries with wet hands.

### CAUTION

Refer to the battery manual for details on handling the batteries.

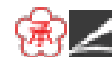

## Transmitter Channel Management

### WARNING

The following actions must be taken to properly receive the transmitter signal of the correct patient on the receiving instrument. Otherwise, there may be signal loss or signals may mix causing a serious accident, such as monitoring a different patient.

- Assign a channel administrator in the hospital and only he or she should manage channel assignment.
- The channel administrator must manage the channels in the facility so that there is no signal interference.
- When the transmitter channel is changed, the channel administrator must check that the channel on the receiving monitor is also changed and the signal is properly received.
- The channel administrator must replace the channel number label on the transmitter with the new one after changing the channel.

## For Patients Using Implantable Pacemaker

### WARNING

Interaction Between Minute Ventilation Rate-Adaptive Pacemakers and Cardiac Monitoring and Diagnostic Equipment\*

The bioelectric impedance measurement sensor of a minute ventilation rate-adaptive implantable pacemaker may be affected by transmitter which is connected to the same patient. If this occurs, the pacemaker may pace at its maximum rate and the transmitter may give incorrect data to the monitor. If this occurs, disconnect the electrode leads from the patient or change the setting on the pacemaker by referring to the pacemaker's manual. For more details, contact your pacemaker representative or Nihon Kohden representative.

- \* Minute ventilation is sensed in rate-adaptive pacemakers by a technology known as bioelectric impedance measurement (BIM). Many medical devices in addition to pacemakers use this technology. When one of these devices is used on a patient with an active, minute ventilation rate-adaptive pacemaker, the pacemaker may erroneously interpret the mixture of BIM signals created in the patient, resulting in an elevated pacing rate.

For more information, see the FDA web site.

<http://www.fda.gov/cdrh/safety.html>



## ECG Monitoring

### WARNING

After attaching the electrode to the patient and connecting the electrode lead to the transmitter, check that electrodes are attached to the patient and check that the electrode lead is connected to the transmitter properly. When the electrodes are removed from the patient, do not touch the metal part of the electrode with bare hands or let the metal part of the electrode contact the metal part of the bed or any other conductive parts. Failure to follow this warning may cause electrical shock or injury to the patient by discharged energy.

### WARNING

The transmitter detects the pacemaker pulse and rejects the pacemaker pulse from the heart rate count. However, all of the pacemaker pulse might not be rejected. If the pacemaker pulse is not rejected, the pacemaker pulse is detected as QRS and false heart rate may be indicated. Keep pacemaker patients under close observation.

- \* For the pacemaker pulse rejection capability of ZM-520PA/521PA/530PA/531PA transmitter refer to the “Specifications - ECG” section.

### WARNING

The pacemaker pulse can be overlooked or detected as QRS. You cannot confirm the pacemaker operation only from the detected pacemaker pulse.

### CAUTION

Only use Nihon Kohden specified electrodes and electrode leads. When other type of electrodes or electrode leads are used, the “CHECK ELECTRODES” message may be displayed and ECG monitoring may stop.

### CAUTION

When the “ELECTRODE OFF” or “CHECK ELECTRODES” message is displayed on the receiving monitor, ECG is not monitored properly and the ECG alarm does not function. Check the electrode, electrode leads, and if necessary, replace with new ones.

### CAUTION

Hold the connector of the electrode lead when connecting/disconnecting the electrode lead. If you disconnect the electrode lead by pulling the lead, it damages the electrode lead.



## SpO<sub>2</sub> Monitoring

### WARNING

SpO<sub>2</sub> measurement may be incorrect in the following cases.

- When the patient's carboxyhemoglobin or methemoglobin increases abnormally.
- When dye is injected in the blood.
- When using an electrosurgical unit.
- During CPR.
- When measuring at a site with venous pulse.
- When there is body movement.
- When the pulse wave is small (insufficient peripheral circulation).

### WARNING

When monitoring SpO<sub>2</sub> of a patient who is receiving photodynamic therapy, the light from the finger probe sensor may cause a burn. Photodynamic therapy uses a photosensitizing agent that has a side effect of photosensitivity.

The SpO<sub>2</sub> probe manufactured by Nihon Kohden have two wavelengths with peaks in the range of 650 and 950 nm. The maximum light intensity is less than 5.5 mW.

### WARNING

- When using the TL-201T finger probe, do not fasten the probe and cable to the finger by wrapping with tape. This may cause burn, congestion or pressure necrosis from poor blood circulation.
- When using probes other than the TL-201T finger probe, to avoid poor circulation, do not wrap the tape too tight. Check the blood circulation condition by observing the skin color and congestion at the skin peripheral to the probe attachment site. Even for short-term monitoring, there may be burn or pressure necrosis from poor blood circulation, especially on neonates or low birth weight infants whose skin is delicate. Accurate measurement cannot be performed on a site with poor peripheral circulation.

### WARNING

Check the circulation condition by observing the skin color at the measurement site and pulse waveform. Change the measurement site every 8 hours for disposable probes and every 4 hours for reusable probes (every 8 hours for TL-631T series probe). The skin temperature may increase at the attached site by 2 or 3°C (4 or 5°F) and cause a burn or pressure necrosis. When using the probe on the following patients, take extreme care and change the measurement site more frequently according to symptoms and degree.

- Patient with a fever
- Patient with insufficient peripheral circulation
- Neonate or low birth weight infant with delicate skin

**WARNING**

When not monitoring SpO<sub>2</sub>, disconnect the SpO<sub>2</sub> cable from the transmitter. Otherwise, noise from the probe sensor may interfere and incorrect data is displayed on the screen.

**CAUTION**

Refer to the probe instruction manual for details.

**CAUTION**

The disposable probe is not sterilized. Use the disposable probe only for a single patient. Never reuse the disposable probe for another patient because it causes cross infection.

**CAUTION**

Do not attach the probe to the same limb that is used for NIBP measurement or an IBP catheter. The SpO<sub>2</sub> measurement may be incorrect.

**CAUTION**

While a patient is on medication which causes vasodilation, the pulse waveform may change and in rare cases the SpO<sub>2</sub> value might not be displayed.

**CAUTION**

Normal external light does not affect monitoring but strong light such as a surgical light or sunlight may affect monitoring. If affected, cover the measuring site with a blanket.

**CAUTION**

When a message indicates a faulty probe, stop monitoring and replace the probe with a new one.

**CAUTION**

Do not use a damaged or disassembled probe. It causes incorrect measurement and may injure the patient.

**CAUTION**

Do not use a probe which is deteriorated by aging. Accurate measurement cannot be performed.

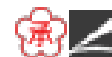
**CAUTION**

If the attachment site is dirty with blood or bodily fluids, clean the attachment site before attaching the probe. If there is nail polish on the attachment site, remove the polish. Otherwise, the amount of transmitted light decreases, and measured value may be incorrect or measurement cannot be performed.

**CAUTION**

If the skin gets irritated or redness appears on the skin from the probe, change the attachment site or stop using the probe. Take extreme care for the patients with delicate skin.

**CAUTION**

Failure to follow these instructions may cause cable discontinuity, short circuit, skin burn on the patient from the probe temperature increase due to the short circuit of the probe cable, and incorrect measurement data. If the probe is broken, replace it with a new one.

- Do not immerse any part of the probe cable other than the disposable probe in chemical solutions or water.
- Do not pull or bend the probe cable.
- Do not let caster feet run over the probe cable.

**CAUTION**

When the probe is attached on an appropriate site with sufficient circulation and the error message confirming the probe attachment repeatedly appears, the probe may be deteriorated. Replace it with a new one.

## Maintenance

**CAUTION**

This transmitter is not waterproof. If detergent or liquid spills into the transmitter, stop cleaning or disinfecting it and contact your Nihon Kohden representative. The transmitter needs to be checked for safety and function before use.

**CAUTION**

Do not immerse the electrode lead connector in liquid.

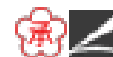

**CAUTION**

Never disassemble or repair the transmitter. If there is any problem with the transmitter, contact your Nihon Kohden representative.

**CAUTION**

Dispose of Nihon Kohden products according to your local laws and your facility's guidelines for waste disposal. Otherwise, it may affect the environment. If there is a possibility that the product may have been contaminated with infection, dispose of it as medical waste according to your local laws and your facility's guidelines for medical waste. Otherwise, it may cause infection.





## Preparation on Transmitter

### Batteries

#### Handling Batteries

#### WARNING

Do not use NiMH batteries for this transmitter. Some operating environments may cause NiMH batteries to produce gas and explode.

#### CAUTION

Refer to the battery manual for details on handling the batteries.

#### CAUTION

Do not handle the batteries with wet hands.

#### CAUTION

When the transmitter is not in use, remove the batteries. When the batteries are installed, battery power is consumed even when measurement is not performed.

#### NOTE

Remove the batteries from the transmitter before disposing of it.

### Battery Lifetime

Use two AA(LR6) type alkaline dry cell batteries. With new Nihon Kohden recommended alkaline batteries, the transmitter can continuously measure for the following number of days at room temperature. Operation time depends on the thickness of the SpO<sub>2</sub> probe attachment site.

Transmitter	Operating time (Measuring parameters)	
	ECG, Resp, SpO <sub>2</sub>	ECG, Resp
ZM-520PA/530PA	2.5 days	3.5 days
ZM-521PA/531PA	2.0 days	2.5 days

### Recommended Batteries

Alkaline primary: Nihon Kohden Medipower (equivalent to Panasonic LR6 (G))



## NOTE

- Use Nihon Kohden Medipower to ensure specified performance. Outdated, mismatched or poor-quality batteries can give unacceptable performance (e.g., insufficient low battery indication). The use of fresh high-quality alkaline batteries is strongly recommended.
- When the display is turned on, it reduces the battery power. Instruct the patient not to turn on the display during monitoring.

## Installing (Replacing) Batteries

### CAUTION

Battery replacement must be performed by the operator. When replacing the batteries of a transmitter that is currently used for a patient, disconnect the electrode leads from the transmitter before replacing batteries or do not touch the patient during replacement.

If electrode leads are attached to the patient and the person replacing batteries touches the patient during battery replacement, excess patient leakage current may flow into the patient.

## NOTE

- Replace all batteries at the same time.
- Do not use different types of batteries together.
- Insert the batteries with the correct polarity (+ and -).

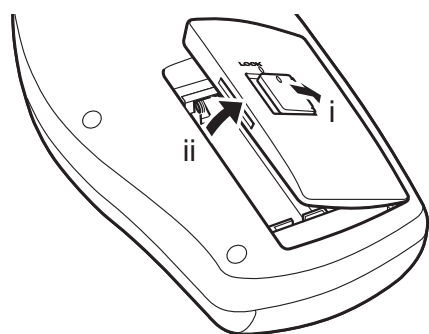

1. Open the battery case cover.

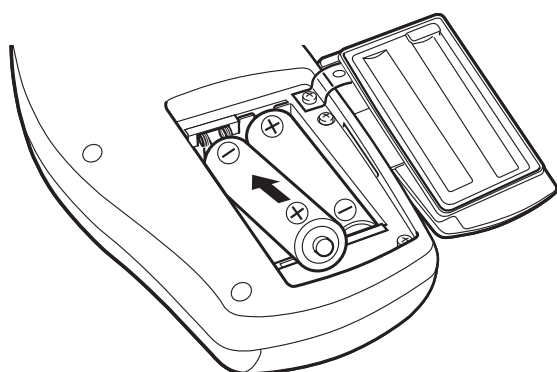

2. Insert two new batteries into the battery case observing the correct polarity.

The transmitter is automatically turned on when the batteries are installed.



## NOTE

Insert the (–) end of the battery first and press it against the spring. If you try to force the (+) end of the battery in first, it will deform the spring and damage the battery and transmitter.

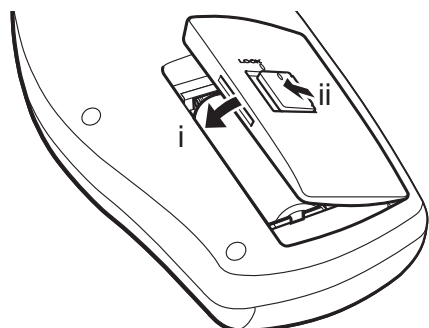

3. Close the cover.





## Situations Requiring Battery Replacement

Replace the batteries when any of the following occurs:

- The transmitter displays the “BATTERY WEAK” message or “” icon.
- The transmitter generates a constant alarm (continuous “peep” sound).
- The transmitter LCD does not display anything when the power is turned on.
- The receiving monitor displays a battery replacement message.

## Battery Level Indication

The following icons on the LCD indicate the battery level. When “PROTOCOL” on the SYSTEM SETUP screen is set to 51, the battery level indication is transmitted to the receiving monitor. To use protocol 51, the ORG-9100A/ORG-9110A multiple patient receiver software version 03-03 or later is required.

Indication	Battery level	Message on the receiving monitor
	Batteries are fully charged.	There is no message on the monitor.
	Batteries are getting low.	
	Batteries are low.	
	Batteries are almost empty. Replace batteries.	Message requiring battery replacement is displayed.
No indication	Dead batteries	No signal can be transmitted to the monitor. There is no indication on the monitor.



## Attaching a Strap to the Transmitter

### NOTE

Do not attach the clip to hard objects such as thick cloth or a zipper. It will break the clip.

Attach a strap to the transmitter and fasten the clip to the patient's clothes or bed sheets.

If the transmitter falls off, the transmitter may be damaged and the batteries may come out. If the patient touches the battery terminal when putting the batteries back in the transmitter, excess patient leakage current may flow into the patient.

If the transmitter falls into water or a toilet, stop using the transmitter and contact your Nihon Kohden representative.

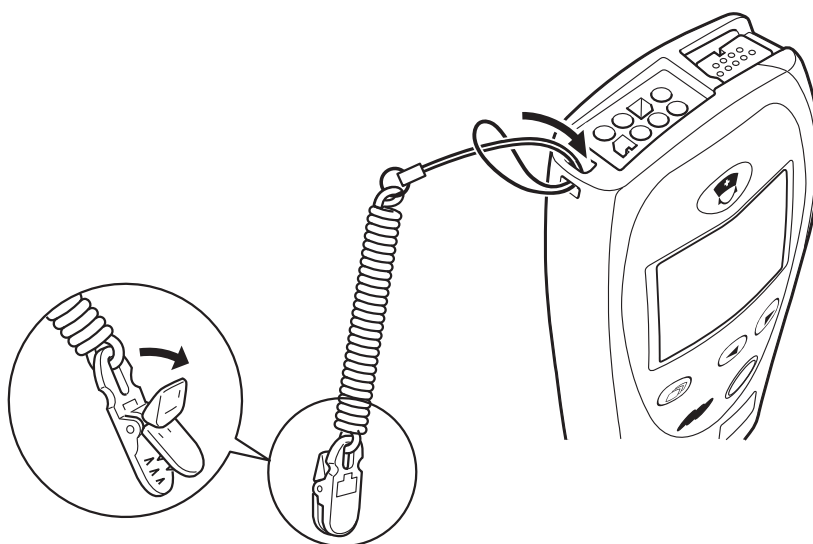



## Turning On the Transmitter

When the batteries are installed correctly, the power is turned on. A one second “peep” sounds and the startup screen appears, then the check electrodes screen appears. (There is no “peep” sound when there is no battery power.)



After checking that the ECG is stable on the check electrodes screen, press the Screen key to display the numeric and waveform screen.



For details on the screen, refer to the “Screen Descriptions” section.

### Check Items Before Use

Before turning on the transmitter power, check the following to confirm that the transmitter can be used in normal and safe condition.

#### Appearance

- There are no damaged or dirty parts on the outside of the transmitter (LCD, keys, sockets, battery case cover, battery case, etc.).
- The transmitter is completely dry.
- The electrodes, electrode lead and SpO<sub>2</sub> probe are not broken.

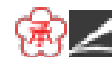

### **Batteries**

- The battery polarity is correct.
- The battery case spring is firmly attached and the battery is not loose.
- The battery case cover is firmly closed.

### **Channel Setting**

- The transmitter channel matches the receiving monitor channel.
- There is no nearby transmitter with the same channel.

### **Other**

- When performing defibrillation, set the hum filter to ON on the receiving monitor. The waveform recovery may become slow due to electrode polarization when the hum filter is set to OFF.

## **Check Items After Power On**

After turning on the power, check the following.

### **Power On**

- The transmitter generates a one second “peep” sound and the startup screen appears.
- The transmitter displays the check electrodes screen.
- The transmitter is not too hot.
- The transmitter does not display the “BATTERY WEAK” message.
- The transmitter does not interfere with the operation of other medical instruments.

### **Daily Check**

- The “signal loss” message is not displayed on the receiving monitor when the transmitter is inside the receiving range of the monitor.
- The battery replacement message is not displayed on the monitor.
- The keys on the transmitter function properly.
- The LCD brightness is appropriate. To adjust brightness, refer to the “Changing SYSTEM SETUP Settings” section.

## **Check Items After Use**

To use the transmitter in safe and optimum condition for next time, check the following.

### **Before Turning Power Off**

- Temporarily changed settings are changed back to the previous settings.
- There was no malfunction on the transmitter.

### **Storage**

- ECG electrode leads and SpO<sub>2</sub> probe are cleaned and disinfected.
- If the transmitter got wet, liquid is wiped off and the transmitter is thoroughly dried.
- There are enough consumables, such as disposable electrodes.
- The transmitter power is turned off by removing batteries from the transmitter.
- Dead batteries are disposed of properly.

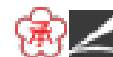

## Turning Off the Transmitter

To turn off the power, remove batteries. When the power is turned off, the saved waveform and numeric data are deleted.

## Changing the Transmitter Channel

The channel of the transmitter can be changed with an optional QI-901PK channel writer.

### WARNING

The following actions must be taken to properly receive the transmitter signal of the correct patient on the receiving instrument. Otherwise, there may be signal loss or signals may mix causing a serious accident, such as monitoring a different patient.

- Assign a channel administrator in the hospital and only he or she should manage channel assignment.
- The channel administrator must manage the channels in the facility so that there is no signal interference.
- When the transmitter channel is changed, the channel administrator must check that the channel on the receiving monitor is also changed and the signal is properly received.
- The channel administrator must replace the channel number label on the transmitter with the new one after changing the channel.

### NOTE

- The software version of the QI-901PK channel writer must be 02-01 or later to change the channel on the transmitter.
- The channel writer must be used outside the patient environment.

The channel is displayed in the upper left corner of the screen.

Channel





## Changing Parameter and System Setup Settings

The initial settings on the PARAMETER SETUP and SYSTEM SETUP screens can only be changed before monitoring. Changing these settings during monitoring interrupts monitoring.

### NOTE

Changing Parameter and System Setup settings must be done by qualified personnel.

## Changing PARAMETER SETUP Settings

### Parameter Setup Setting List

The factory default settings are underlined.

Setting item	Description	Settings
ECG ELECTRODES	Select the electrode lead type.	<u>IEC</u> , <u>AHA</u>
LEAD TYPE	Select the type of ECG leads.	<u>AUTO</u> , 6 LEADS
ECG MEASUREMENT	<p>Turn ECG monitoring on or off. When electrodes are attached to the patient and ECG leads are connected, ECG monitoring starts even when this setting is set to OFF.</p> <p>If this setting is set to OFF, the same setting on the receiving monitor must also be set to OFF.</p> <p style="text-align: center;"><b>NOTE</b></p> <p>When "PROTOCOL" on the transmitter is set to 51 and the receiving monitor is able to receive protocol 51, ECG measurement on the receiving monitor is automatically set to OFF when this setting is set to OFF on the transmitter.</p> <p>To use protocol 51, the ORG-9100A/ORG-9110A multiple patient receiver software version 03-03 or later is required.</p>	<u>ON</u> , OFF
RESP MEASUREMENT	<p>Turn respiration monitoring on or off.</p> <p>When this setting is set to OFF, the same setting on the receiving monitor is automatically set to OFF.</p>	<u>ON</u> , OFF





Setting item	Description	Settings
SpO <sub>2</sub> RESPONSE	<p>Select the SpO<sub>2</sub> response mode.</p> <p>FAST: Select this for special applications that require a fast response. FAST is suitable for detecting short apnea.</p> <p>NORMAL: For normal monitoring.</p> <p>SLOW: Select this when you need to suppress a rapid change in SpO<sub>2</sub>.</p>	FAST, <u>NORMAL</u> , SLOW

## Displaying the PARAMETER SETUP Screen

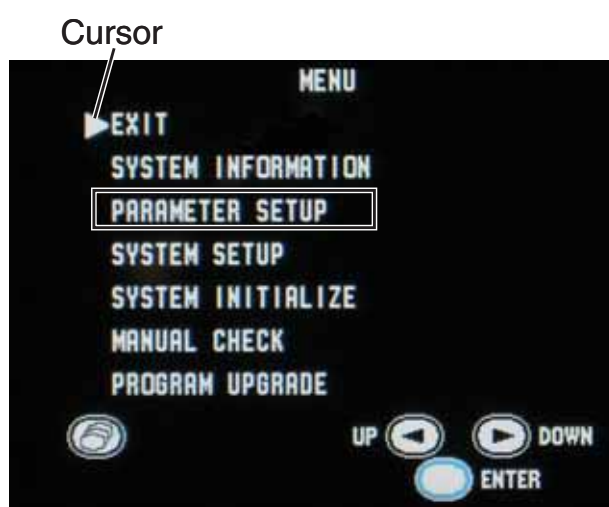

MENU screen

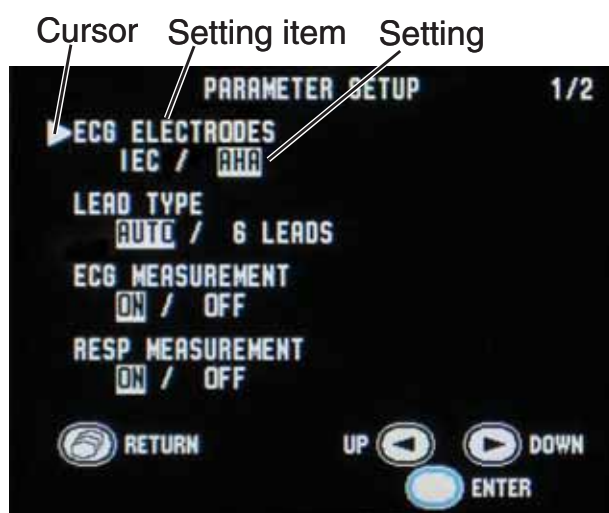

PARAMETER SETUP screen - page 1

1. Turn off the transmitter by removing one battery.
2. While pressing the Function key, turn on the transmitter (install the battery). The MENU screen appears.
3. Press the key to move the cursor to "PARAMETER SETUP".
4. Press the Function key to enter PARAMETER SETUP. The current settings are highlighted.
5. Change settings:
  - To move the cursor and select the setting item, press the or key then press the Function key.
  - To select and register the setting, press the or key then press the Function key.
  - To cancel changing the setting of the selected item, press the Screen key.
6. When changing settings on the PARAMETER SETUP screen is complete, press the Screen key to return to the MENU screen.

7. Press the or key to move the cursor to "EXIT".

8. Press the Function key. The numeric and waveform screen appears.



## Changing Parameter Setup Settings

### ECG ELECTRODES

Select the electrode lead type.

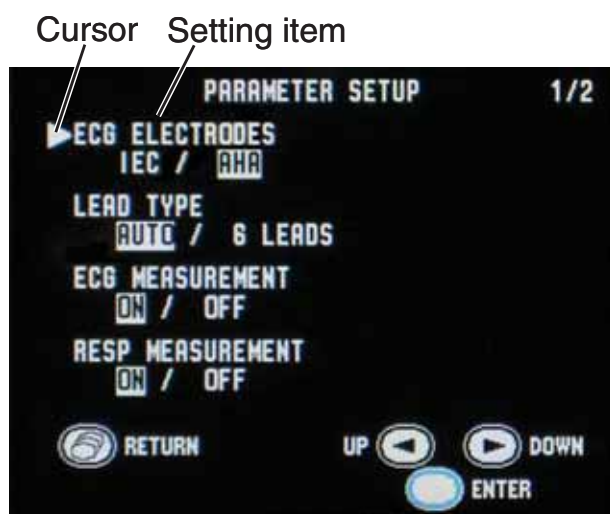

1. On the PARAMETER SETUP screen, press the  key to move the cursor to “ECG ELECTRODES”.

2. Press the Function key. The cursor moves to the selection item.

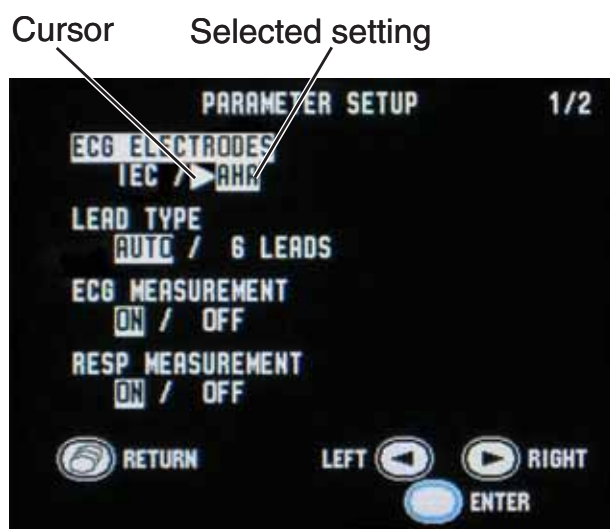

3. Press the  key to select “IEC” or “AHA”.

4. Press the Function key to register the selected setting. The cursor returns to “ECG ELECTRODES”.

### LEAD TYPE

Select the type of ECG leads. In normal use, select “AUTO”. When using DIN type lead with 6 electrodes, select “6 LEADS”.

1. On the PARAMETER SETUP screen, press the  key to move the cursor to “LEAD TYPE”.

2. Press the Function key.

3. Press the  key to select “AUTO” or “6 LEADS”.

4. Press the Function key to register the selected setting. The cursor returns to “LEAD TYPE”.

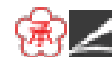



## ECG MEASUREMENT

Turn ECG monitoring on or off. When electrodes are attached to the patient and ECG leads are connected, ECG monitoring starts even when this setting is set to OFF.

If this setting is set to OFF, the same setting on the receiving monitor must also be set to OFF.



### NOTE

When "PROTOCOL" on the transmitter is set to 51 and the receiving monitor is able to receive protocol 51, ECG measurement on the receiving monitor is automatically set to OFF when this setting is set to OFF on the transmitter. To use protocol 51, the ORG-9100A/ORG-9110A multiple patient receiver software version 03-03 or later is required.

1. On the PARAMETER SETUP screen, press the  key to move the cursor to "ECG MEASUREMENT".
2. Press the Function key.
3. Press the  key to select "ON" or "OFF".
4. Press the Function key to register the selected setting. The cursor returns to "ECG MEASUREMENT".

## RESP MEASUREMENT

Turn respiration monitoring on or off. When this setting is set to OFF, the same setting on the receiving monitor is automatically set to OFF.

1. On the PARAMETER SETUP screen, press the  key to move the cursor to "RESP MEASUREMENT".
2. Press the Function key.
3. Press the  key to select "ON" or "OFF".
4. Press the Function key to register the selected setting. The cursor returns to "RESP MEASUREMENT".



## SpO<sub>2</sub> RESPONSE

Select the SpO<sub>2</sub> response mode.



**FAST:** Select this for special applications that require a fast response. FAST is suitable for detecting short apnea.

**NORMAL:** For normal monitoring.

**SLOW:** Select this when you need to suppress a rapid change in SpO<sub>2</sub>.



PARAMETER SETUP screen - page 2

1. On the PARAMETER SETUP screen, press the  key to move the cursor to “SpO<sub>2</sub> RESPONSE”. “SpO<sub>2</sub> RESPONSE” is on the second page of the PARAMETER SETUP screen.
2. Press the Function key.
3. Press the  key to select “FAST”, “NORMAL” or “SLOW”.
4. Press the Function key to register the selected setting. The cursor returns to “SpO<sub>2</sub> RESPONSE”.



## Changing SYSTEM SETUP Settings

### System Setup Setting List





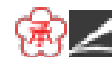

The factory default settings are underlined.

Setting Item	Description	Settings
PROTOCOL	<p>Select the transmitting protocol.</p> <p>51: New protocol. A central monitor with ORG-9100A/9110A multiple patient receiver whose software version 03-03 or later can receive this protocol.</p> <p>41: Old protocol. A central monitor with ORG-9100A/9110A/9700A multiple patient receiver can receive this protocol.</p> <p style="text-align: center;"><b>NOTE</b></p> <p>When 51 is set, the receiving monitor must be able to receive protocol 51. Otherwise, signals from the transmitter cannot be received. To use protocol 51, the ORG-9100A/ORG-9110A multiple patient receiver software version 03-03 or later is required.</p>	51, <u>41</u>
BRIGHTNESS	Select the screen brightness.	<u>DARK</u> , BRIGHT
FUNCTION KEY	<p>Select the function of the Function key.</p> <p><b>SUSPEND ALARM &amp; PAUSE:</b> Suspends alarm on the receiving monitor for 2 minutes. Pauses monitoring on the transmitter and receiving monitor.</p> <p><b>SUSPEND ALARM:</b> Suspends alarm on the receiving monitor for 2 minutes.</p> <p><b>CONFIRM:</b> Displays the "PATIENT CONFIRMED" message on the transmitter screen and transmits the message to the receiving monitor.</p> <p><b>OFF:</b> No function.</p> <p style="text-align: center;"><b>NOTE</b></p> <p>"SUSPEND ALARM &amp; PAUSE" and "CONFIRM" can only be set when PROTOCOL is set to 51. To use protocol 51, the ORG-9100A/ORG-9110A multiple patient receiver software version 03-03 or later is required.</p>	SUSPEND ALARM & PAUSE, SUSPEND ALARM, CONFIRM, <u>OFF</u>



Setting Item	Description	Settings
AUTO RESUME AFTER PAUSE	Select the interval to resume monitoring after PAUSE.	10 s, 30 s, 1 min, 2 min, <u>3 min</u> , OFF

## Displaying the SYSTEM SETUP Screen

1. Turn off the transmitter by removing one battery.
2. While pressing the Function key, turn on the transmitter (insert the battery). The MENU screen appears.
3. Press the  key to move the cursor to "SYSTEM SETUP".
4. Press the Function key to enter SYSTEM SETUP. The current settings are highlighted.
5. Change settings.
  - To move the cursor and select the setting item, press the  or  key then press the Function key.
  - To select and register the setting, press the  or  key then press the Function key.
  - To cancel changing the setting of the selected item, press the Screen key.
6. When changing settings on the SYSTEM SETUP screen is complete, press the Screen key to return to the MENU screen.
7. Press the  or  key to move the cursor to "EXIT".
8. Press the Function key. The numeric and waveform screen appears.

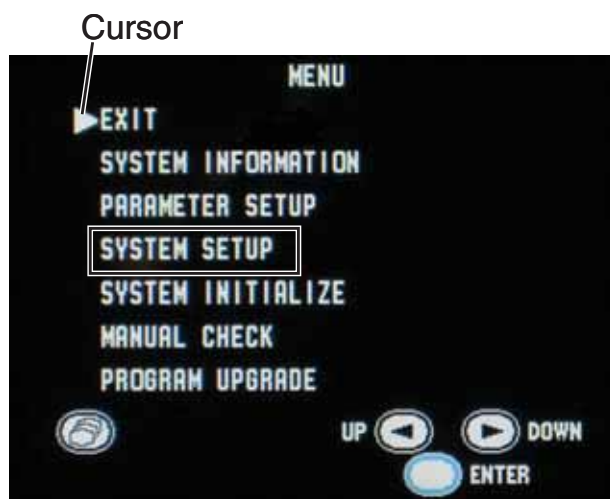

MENU screen

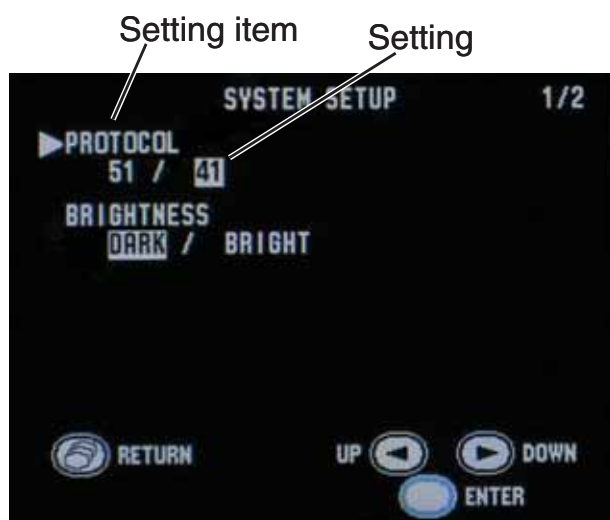

SYSTEM SETUP screen - page 1

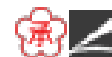

## Changing System Setup Settings

### PROTOCOL

Select the transmitting protocol. For differences between protocols, refer to the table below.

51: New protocol. A central monitor with ORG-9100A/9110A multiple patient receiver whose software version 03-03 or later can receive this protocol.

41: Old protocol. A central monitor with ORG-9100A/9110A/9700A multiple patient receiver can receive this protocol.



### NOTE

When 51 is set, the receiving monitor must be able to receive protocol 51. Otherwise, signals from the transmitter cannot be received.

### Differences Between Protocols

Function	Protocol 41	Protocol 51
Setting ECG MEASUREMENT to OFF on the transmitter automatically turns off the ECG measurement setting on the receiving monitor	No (ECG measurement must be turned off on the receiving monitor)	Yes
Pause monitoring on the receiving monitor from the transmitter	No	Yes
Transmit "PATIENT CONFIRMED" message	No	Yes
Display battery level of the transmitter on the receiving monitor	No	Yes
Transmit SpO <sub>2</sub> messages	Some messages (refer to the "Indication and Message List" section)	All messages
Transmit RESP message	No	Yes



1. Press the  key to move the cursor to "PROTOCOL".
2. Press the Function key.
3. Press the  key to select "51" or "41".







## NOTE

FUNCTION KEY (on the second page of the SYSTEM SETUP screen) can be set to “SUSPEND ALARM & PAUSE” or “CONFIRM” only when PROTOCOL is “51”. If PROTOCOL is changed to “41”, FUNCTION KEY is automatically changed to “OFF”.

4. Press the Function key to register the selected setting. The cursor returns to “PROTOCOL”.

## BRIGHTNESS

Select the screen brightness.

1. Press the  key to move the cursor to “BRIGHTNESS”.
2. Press the Function key.
3. Press the  key to select “DARK” or “BRIGHT”.
4. Press the Function key to register the selected setting. The cursor returns to “BRIGHTNESS”.

## FUNCTION KEY

Select the function of the Function key. For details on using these functions, refer to “Basic Monitoring Operation” in the “Monitoring” section.

**SUSPEND ALARM & PAUSE:** Suspends alarm on the receiving monitor for 2 minutes. Pauses monitoring on the transmitter and receiving monitor.

**SUSPEND ALARM:** Suspends alarm on the receiving monitor for 2 minutes.

**CONFIRM:** Displays the “PATIENT CONFIRMED” message on the transmitter screen and transmits the message to the receiving monitor.

**OFF:** No function.

## NOTE

“SUSPEND ALARM & PAUSE” and “CONFIRM” can only be set when PROTOCOL is set to 51.





SYSTEM SETUP screen - page 2

1. On the SYSTEM SETUP screen, press the key to move the cursor to “FUNCTION KEY”. “FUNCTION KEY” is on the second page of the SYSTEM SETUP screen.
2. Press the Function key.
3. Press the key to select the function.
4. Press the Function key to register the selected setting. The cursor returns “FUNCTION KEY”.

### AUTO RESUME AFTER PAUSE

Select the interval to resume monitoring after PAUSE. When one of the following conditions is met, monitoring resumes on the receiving monitor. When OFF is selected, monitoring does not automatically resume.

- Heart rate is properly monitored for the selected interval
- SpO<sub>2</sub> is properly monitored for the selected interval

1. Press the key to move the cursor to “AUTO RESUME AFTER PAUSE”. “AUTO RESUME AFTER PAUSE” is on the second page of the SYSTEM SETUP screen.
2. Press the Function key.
3. Press the key to select interval.
4. Press the Function key to register the selected setting. The cursor returns to “AUTO RESUME AFTER PAUSE”.

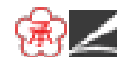

## Initializing Settings

Do the following procedure to initialize all settings, except for channel, to the factory default settings.

Cursor



1. Turn off the transmitter by removing a battery.
2. While pressing the Function key, turn on the transmitter (put back the battery). The MENU screen appears.
3. Press the  key to move the cursor to “SYSTEM INITIALIZE”.



4. Press the Function key to enter SYSTEM INITIALIZE screen.
5. Press the Function key to initialize settings. The confirmation message appears.

To return to the MENU screen without initializing, press the Screen key.



6. Press the Function key to initialize settings. To cancel initializing, press the  key. The screen returns to the MENU screen.



## Attaching Electrodes and SpO<sub>2</sub> Probe to the Patient

### Attaching Electrodes

#### Selecting Electrode Lead

#### CAUTION

Only use Nihon Kohden specified electrodes and electrode leads. When other type of electrodes or electrode leads are used, the "CHECK ELECTRODES" message may be displayed and ECG monitoring may stop.

The following electrodes and leads can be used on the transmitter (option).

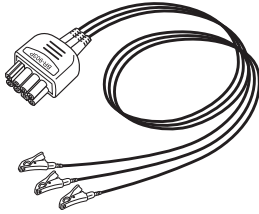
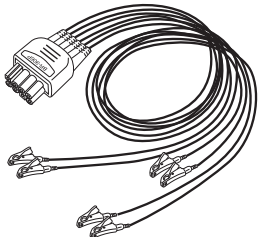
No. of Electrodes	Disposable Electrodes	Electrode Lead
3 (I, II, III)	Vitrode F-150M, F-150S, L-150, L-150X	BR-903PA (AHA, clip type) 
	Disposable Electrode with DIN type lead, Vitrode V-090M3, V-09IO3, V-120S3, N-03IS3	
6 (I, II, III, aVR, aVL, aVF, 2 from V1 to V6)	Vitrode F-150M, F-150S, L-150, L-150X	BR-906PA (AHA, clip type) 
	Disposable Electrode with DIN type lead, Vitrode V-040M4, V-04IO4, V-060M6, V-06IO6	



## Connecting the Electrode Lead to the Transmitter

Connect the electrode lead to the ECG/RESP socket on the transmitter.

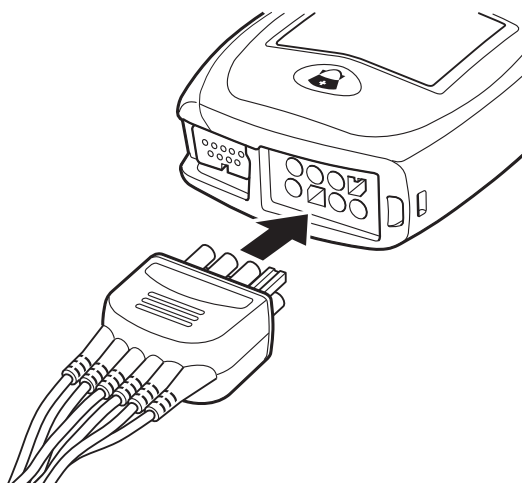

### WARNING

After attaching the electrode to the patient and connecting the electrode lead to the transmitter, check that electrodes are attached to the patient and check that the electrode lead is connected to the transmitter properly. When the electrodes are removed from the patient, do not touch the metal part of the electrode with bare hands or let the metal part of the electrode contact the metal part of the bed or any other conductive parts. Failure to follow this warning may cause electrical shock or injury to the patient by discharged energy.

### CAUTION

Do not shake or swing the transmitter while holding the leads or cables connected to the transmitter. The transmitter may come off and injure someone or damage surrounding instruments.

### CAUTION

Hold the connector of the electrode lead when connecting/disconnecting the electrode lead. If you disconnect the electrode lead by pulling the lead, it damages the electrode lead.



## Electrode Position

Follow the physician's instructions for electrode placement when available.

For ECG monitoring, electrodes are attached only on the chest to allow patient movement and obtain continuous stable ECG. The following leads are examples. When also monitoring respiration, refer to the "Electrode Position for Respiration Monitoring" section.

### NOTE

The optimum electrode positions for ECG measurement are not always optimum for respiration measurement. Select positions that are suitable for both ECG and respiration measurement or positions which give priority to either ECG or respiration measurement.

## Electrode Positions for ECG Monitoring

### Six Electrodes

The 6-electrode method with lead II and lead V5 is effective for monitoring myocardial ischemia. You can improve monitoring accuracy considerably by adding lead V4 to this combination. Va and Vb can be at any position of the standard 12 leads V1 to V6, but V4 and V5 are most appropriate for myocardial ischemic monitoring.

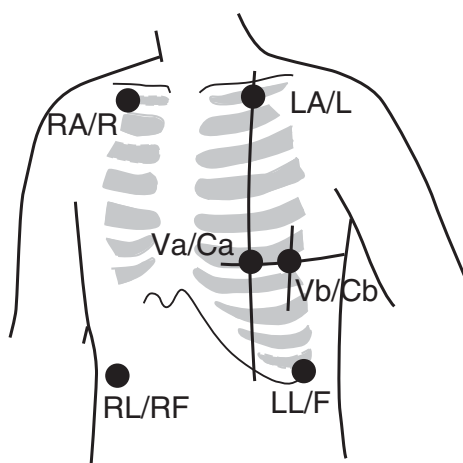

Electrode Position	Symbol		Lead Color	
	AHA	IEC	AHA	IEC
Left infraclavicular fossa	LA	L	Black	Yellow
Right infraclavicular fossa	RA	R	White	Red
Below lowest rib on the left anterior axillary line	LL	F	Red	Green
Right anterior axillary line at the same level as LL/F	RL	RF	Green	Black
Fifth intercostal space on the left midclavicular line (V4 position of standard 12 leads)	Va	Ca	Brown-blue	White-brown
Left anterior axillary line at the same level as Va (V5 position of standard 12 leads)	Vb	Cb	Brown-orange	White-black



### Lead Position

#### Standard limb leads

##### Lead I

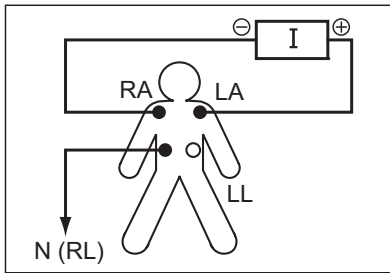

##### Lead II

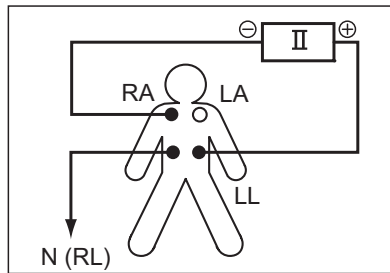

##### Lead III

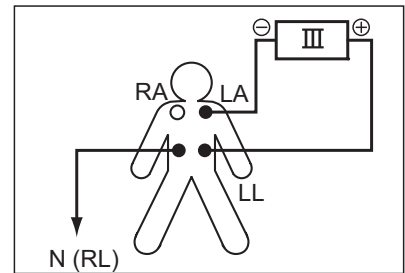

#### Monopolar limb leads

##### a<sub>V</sub>R lead

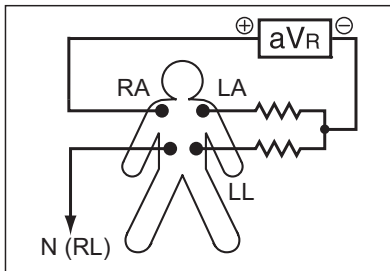

##### a<sub>V</sub>L lead

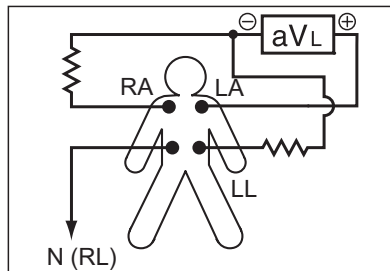

##### a<sub>V</sub>F lead

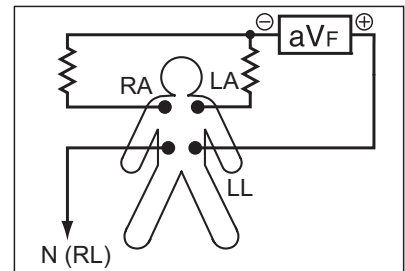

#### Monopolar chest leads

##### V<sub>1</sub> to V<sub>6</sub> leads

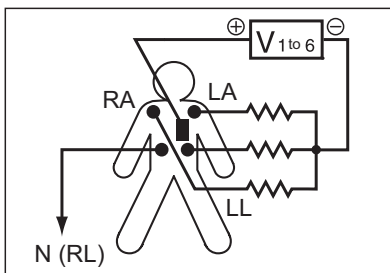

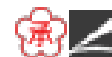

### Three Electrodes

- Lead MII, which is similar to standard lead II, used when ECG measurement has priority

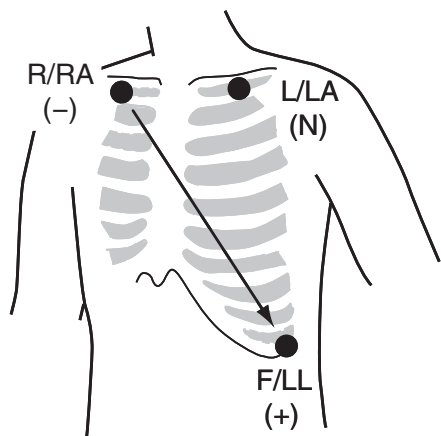

Electrode Position	Symbol		Lead Color	
	AHA	IEC	AHA	IEC
Left infraclavicular fossa	LA	L	Black	Yellow
Right infraclavicular fossa	RA	R	White	Red
Below lowest rib on the left anterior axillary line	LL	F	Red	Green

- Lead MI, which is similar to standard lead I  
Change F/LL and L/LA of lead MII.

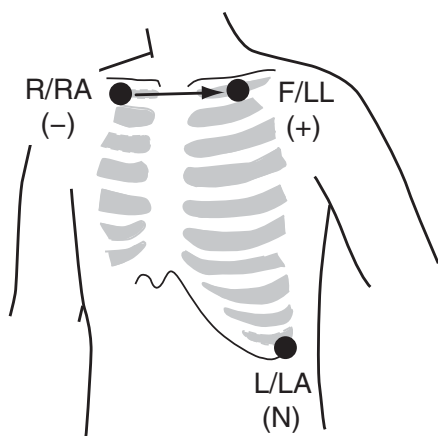

- Lead MIII, which is similar to standard lead III  
Change R/RA and L/LA of lead MII.

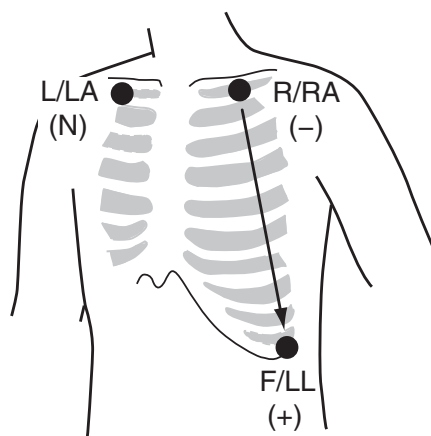

If the electrode positions above are not available due to chest surgery, attach the electrodes to the root of the limbs or below the clavicles for stable ECG monitoring.

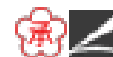

### Electrode Positions for Respiration Monitoring

Place the R/RA and F/LL electrodes so that the lungs are between the electrodes.

#### Position 1

In this position, respiration measurement is available; however, there is a difference in amplitude between different patients.

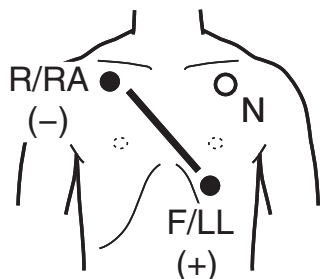

R or RA	F or LL
Right infraclavicular fossa	Fifth intercostal space on the left midclavicular line, V4

#### Position 2

In this position, the waveform amplitude is usually large and the ECG lead is similar to Lead MII. This position can be generally recommended.

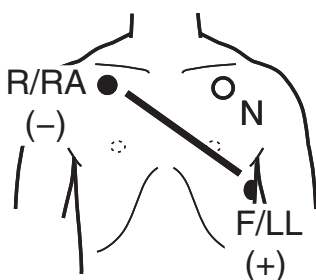

R or RA	F or LL
Right infraclavicular fossa	Fifth intercostal space on the left midaxillary line, V6

#### Position 3

In this position, the respiration waveform is optimum, but the ECG lead is unusual.

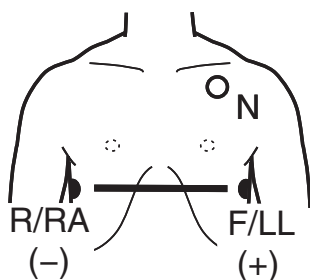

R or RA	F or LL
Right midaxillary at the horizontal level of V6	Fifth intercostal space on the left midaxillary line, V6





#### Position 4

In this position, the respiration measurement is influenced by the impedance variation of the abdomen, so the cardiac pulse wave included in the respiration wave is reduced. Note that the waveform is inverted in phase compared with the chest movement (the waveform goes down during inspiration). It is difficult to measure the ECG at the same time.

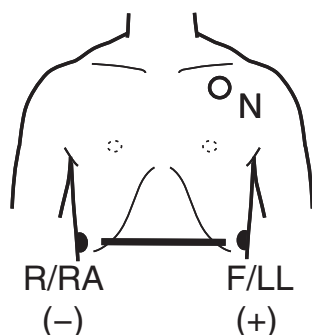

R or RA	F or LL
Lowest rib on the right anterior axillary line	Lowest rib on the left anterior axillary line

## Attaching Electrodes to the Patient and Connecting the Electrode Leads to Disposable Electrodes

### Prepare the Patient Skin

Shave off excessive body hair.

To reduce skin impedance, clean the electrode site with cream or with a cotton pad moistened with alcohol. Thoroughly dry the skin with a clean cotton pad.

### NOTE

- For a patient with frequent body movement, rub the sites with skinPure skin preparation gel. However, do not use skinPure skin preparation gel on sensitive skin.
- Do not place electrodes on a wound or on an inflamed, wrinkled or uneven skin surface.

### Attaching Electrodes to the Patient

### CAUTION

Do not reuse disposable parts and accessories.

### NOTE

- To maintain good contact between the electrode and skin, check that the paste of the disposable electrode is not dry.
- When contact between the disposable electrode and skin becomes poor, replace electrodes with new ones immediately. Otherwise, contact impedance between the skin and the electrode increases and accurate ECG and respiration waveforms cannot be obtained.



Refer to the electrode operator's manual for details.

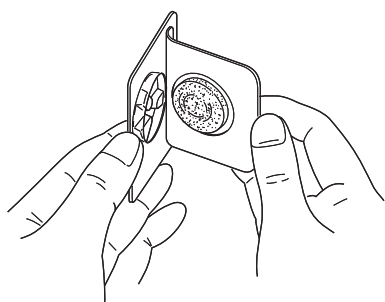

1. Carefully remove the backing paper from the electrode. Avoid touching the adhesive surface.
2. Place the electrode on the previously cleaned skin. Pay attention to the electrode lead color and symbol.
3. Clip the electrode lead to the electrode.
4. Fasten the electrode lead wire with surgical tape with an extra length of wire between the tape and the electrode. This lessens the movement of electrode leads by body movement and helps stable monitoring.

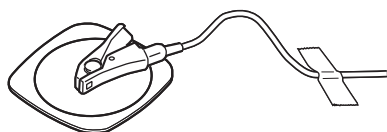

## Checking ECG on the Transmitter Screen

After attaching electrodes and connecting ECG leads, check that the electrodes are properly attached to the patient and the ECG waveform is acquired on the check electrodes screen. For details on the screen, refer to the "Screen Descriptions" section.

## Attaching the SpO<sub>2</sub> Probe

### Selecting the SpO<sub>2</sub> Probe

Select an appropriate probe for the patient.

#### CAUTION

Only use Nihon Kohden specified electrodes, electrode leads and SpO<sub>2</sub> probes. Otherwise, the maximum performance from the transmitter cannot be guaranteed.

#### CAUTION

Do not use a damaged or disassembled probe. It causes incorrect measurement and may injure the patient.



## Reusable Probes

When using a TL-201T finger probe, choose the appropriate cable length for attachment.

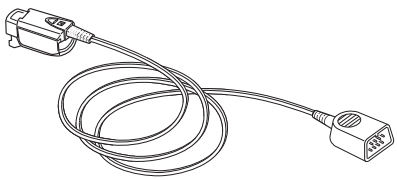
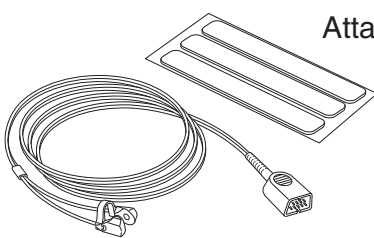
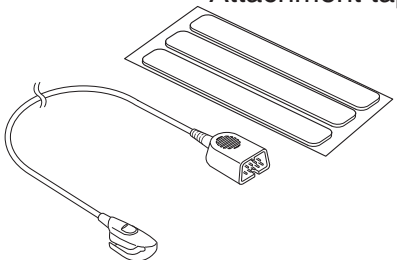
Probe	Cable Length	Patient	Attachment Site		
Finger probe TL-201T 	0.6 m	Adult or child 20 kg or more	Finger		
	1.6 m				
Multi-site probe TL-220T 	Attachment tape		Adult or infant 3 kg or more	Finger or toe	
			Neonate 3 kg or less	Instep and sole	
Finger probe TL-631T1, TL-631T3 	Attachment tape		TL-631T1: 0.6 m	Adult or child 20 kg or more	Finger or toe
			TL-631T3: 1.6 m		

## Disposable Probes

### CAUTION

The disposable probe is not sterilized. Use the disposable probe only for a single patient. Never reuse the disposable probe for another patient because it causes cross infection.

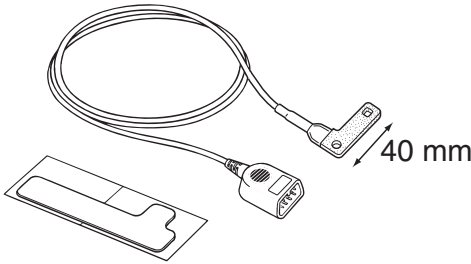
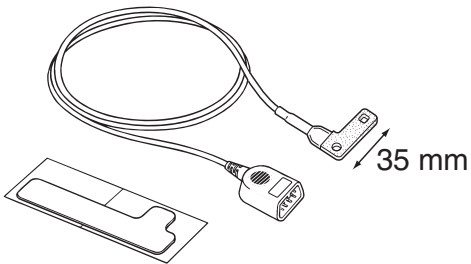
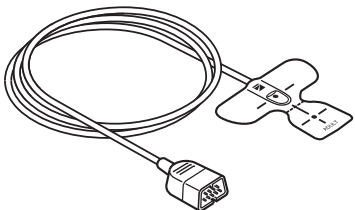
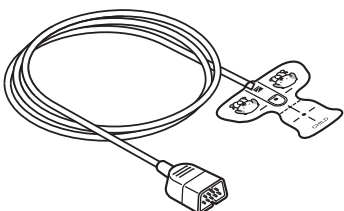

Probe	Patient	Attachment Site
TL-051S, TL-052S  Cable length TL-051S: 0.8 m TL-052S: 1.6 m	Adult 50 kg or more	Finger
	Neonate 3 kg or less	Instep and sole
TL-061S, TL-062S  Cable length TL-061S: 0.8 m TL-062S: 1.6 m	Adult or child 15 to 50 kg	Finger
	Infant 3 to 15 kg	Toe
TL-271T, TL-271T3  Cable length TL-271T: 0.8 m TL-271T3: 1.6 m	Adult 30 kg or more	Finger or toe
TL-272T, TL-272T3  Cable length TL-272T: 0.8 m TL-272T3: 1.6 m	Child 10 to 50 kg	

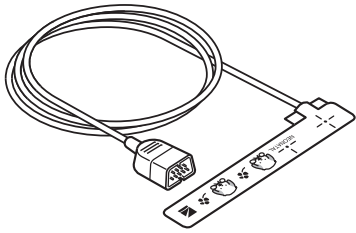
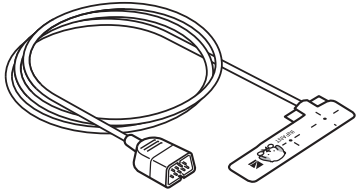

Probe	Patient	Attachment Site
 <p>Cable length TL-273T: 0.8 m TL-273T3: 1.6 m</p>	Neonate 3 kg or less	Instep and sole
	Adult 40 kg or more	Finger or toe
 <p>Cable length TL-274T: 0.8 m TL-274T3: 1.6 m</p>	Infant 3 to 20 kg	Finger or toe

## Connecting the SpO<sub>2</sub> Probe to the Transmitter

Connect the probe to the SpO<sub>2</sub> socket on the transmitter.

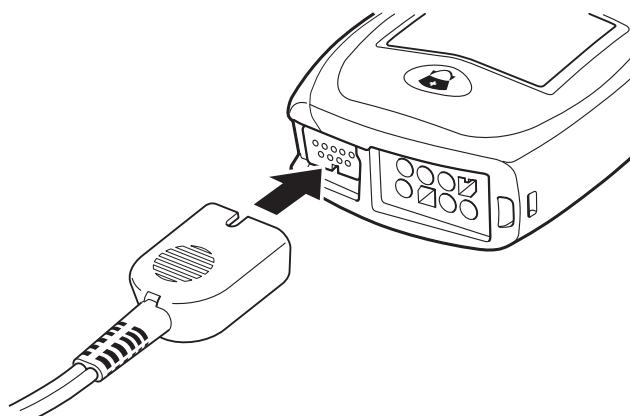

### CAUTION

Do not shake or swing the transmitter while holding the leads or cables connected to the transmitter. The transmitter may come off and injure someone or damage surrounding instruments.

### CAUTION

Do not use a damaged or disassembled probe. It causes incorrect measurement and may injure the patient.

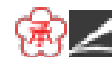

## Attaching the Probe to the Patient

Attach the probe to the patient by referring to the probe's manual. Make sure that the light emitter and photo detector of the probe face each other at the attachment site.

### WARNING

- When using the TL-201T finger probe, do not fasten the probe and cable to the finger by wrapping with tape. This may cause burn, congestion or pressure necrosis from poor blood circulation.
- When using probes other than the TL-201T finger probe, to avoid poor circulation, do not wrap the tape too tight. Check the blood circulation condition by observing the skin color and congestion at the skin peripheral to the probe attachment site. Even for short-term monitoring, there may be burn or pressure necrosis from poor blood circulation, especially on neonates or low birth weight infants whose skin is delicate. Accurate measurement cannot be performed on a site with poor peripheral circulation.

### WARNING

- Check the circulation condition by observing the skin color at the measurement site and pulse waveform. Change the measurement site every 8 hours for disposable probes and every 4 hours for reusable probes (every 8 hours for TL-631T series probe). The skin temperature may increase at the attached site by 2 or 3°C (4 or 5°F) and cause a burn or pressure necrosis. When using the probe on the following patients, take extreme care and change the measurement site more frequently according to symptoms and degree.
- Patient with a fever
  - Patient with insufficient peripheral circulation
  - Neonate or low birth weight infant with delicate skin

### WARNING

When monitoring SpO<sub>2</sub> of a patient who is receiving photodynamic therapy, the light from the finger probe sensor may cause a burn. Photodynamic therapy uses a photosensitizing agent that has a side effect of photosensitivity.

The SpO<sub>2</sub> probe manufactured by Nihon Kohden have two wavelengths with peaks in the range of 650 and 950 nm. The maximum light intensity is less than 5.5 mW.

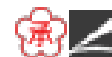
**CAUTION**

If the attachment site is dirty with blood or bodily fluids, clean the attachment site before attaching the probe. If there is nail polish on the attachment site, remove the polish. Otherwise, the amount of transmitted light decreases, and measured value may be incorrect or measurement cannot be performed.

**CAUTION**

When the probe is attached on an appropriate site with sufficient circulation and the error message confirming the probe attachment repeatedly appears, the probe may be deteriorated. Replace it with a new one.

**CAUTION**

If the skin gets irritated or redness appears on the skin from the probe, change the attachment site or stop using the probe. Take extreme care for the patients with delicate skin.

**CAUTION**

Do not use a probe which is deteriorated by aging. Accurate measurement cannot be performed.

**CAUTION**

Refer to the probe instruction manual for details.

**CAUTION**

The disposable probe is not sterilized. Use the disposable probe only for a single patient. Never reuse the disposable probe for another patient because it causes cross infection.



## Locking the Keys on the Transmitter



To prevent the patient from pressing the keys on the transmitter during monitoring, you can lock the keys.

Press the  and  keys at the same time and hold for more than 3 seconds. The key lock screen appears.



When there is no key operation for one minute after locking the keys, the display turns off.

To unlock the keys:

Press the  and  keys at the same time and hold for more than 3 seconds.



## Monitoring

### CAUTION

The measurement values and displayed waveforms on the transmitter and receiving monitor may be different due to timing delay of the display or difference in detection settings.

### NOTE

Do not let the transmitter continuously contact the patient's skin directly. The transmitter heats up by 2 or 3°C (4 or 5°F) during operation and it may cause low temperature burn to the patient.

## Screen Descriptions

When the transmitter is turned on, the startup screen appears, then the check electrodes screen to check the electrode attachment appears.

The screen changes in the following order each time the Screen key is pressed.

Check electrodes → numeric and waveform → waveform review → numeric review → display off → check electrodes . . .

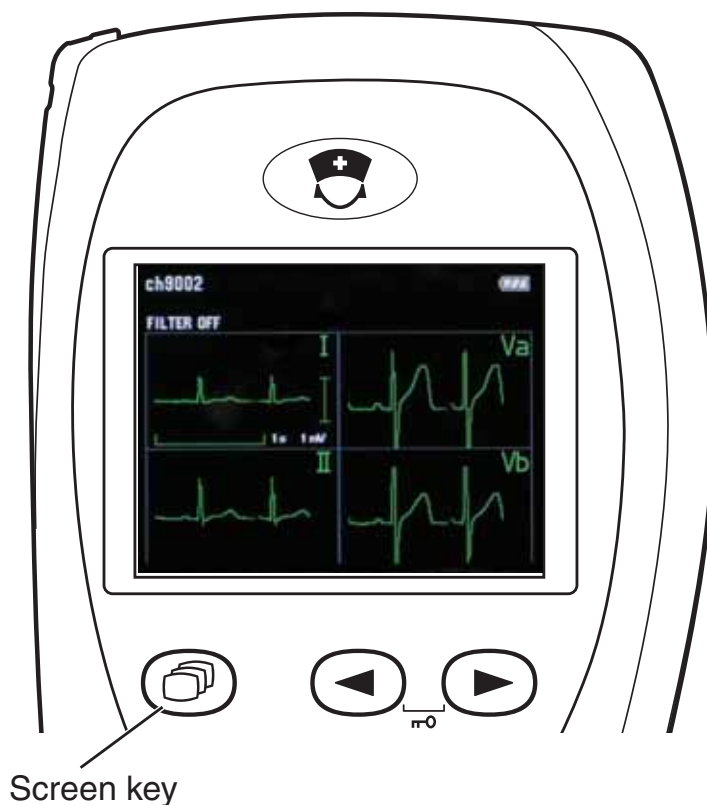



The screen automatically turns off when there is no key operation for 2 minutes on the check electrodes screen or 1 minute on other screens.

When the display is off and the Screen key is pressed, the numeric and waveform screen appears.

### **NOTE**

When the screen before the display off is check electrodes screen and the Screen key is pressed within 5 minutes after the display off, the check electrodes screen appears.



## Check Electrodes Screen

You can check whether the electrodes are properly attached to the patient and the ECG waveform is acquired.

When 6 leads are used, I, II, Va and Vb lead waveforms are displayed.

When 3 leads are used, only II lead waveform is displayed.

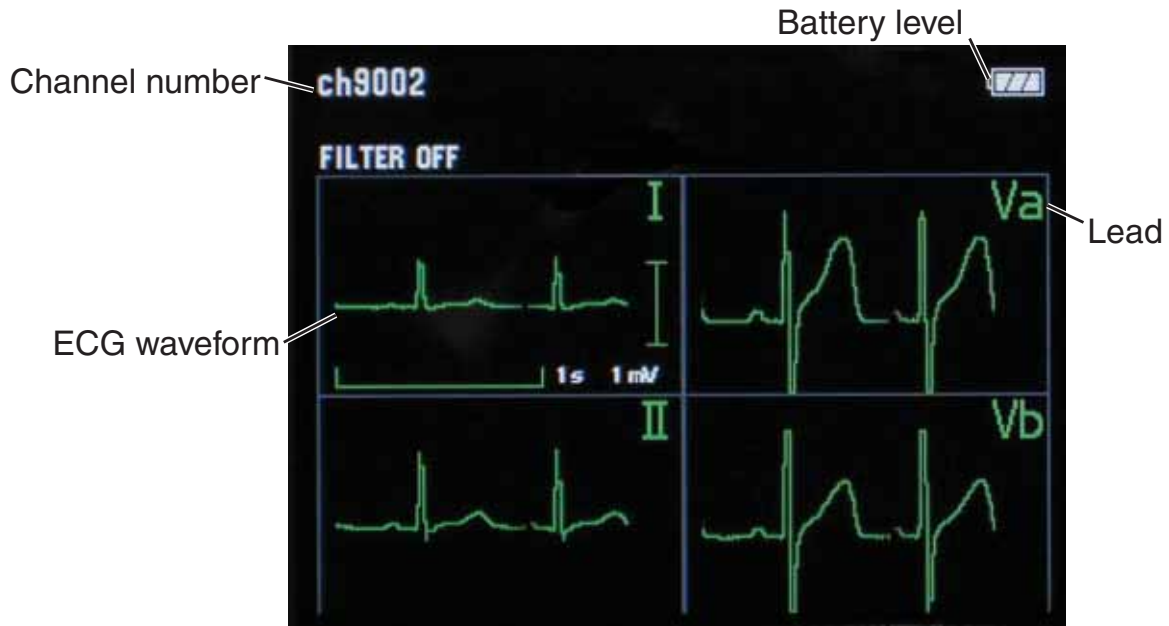

Filter: off  
 Sweep speed: 12.5 mm/s  
 Waveform sensitivity: 0.5 cm/1 mV



Detached electrode position

When electrodes are detached, the “CHECK ELECTRODES” message and detached electrode position appear on the screen.

### NOTE

When ECG measurement is set to OFF on the PARAMETER SETUP screen, the check electrodes screen does not appear.



### Numeric and Waveform Screen

Numeric values and waveforms of the monitoring parameters are displayed. You can change the ECG lead with the **←** and **→** keys.

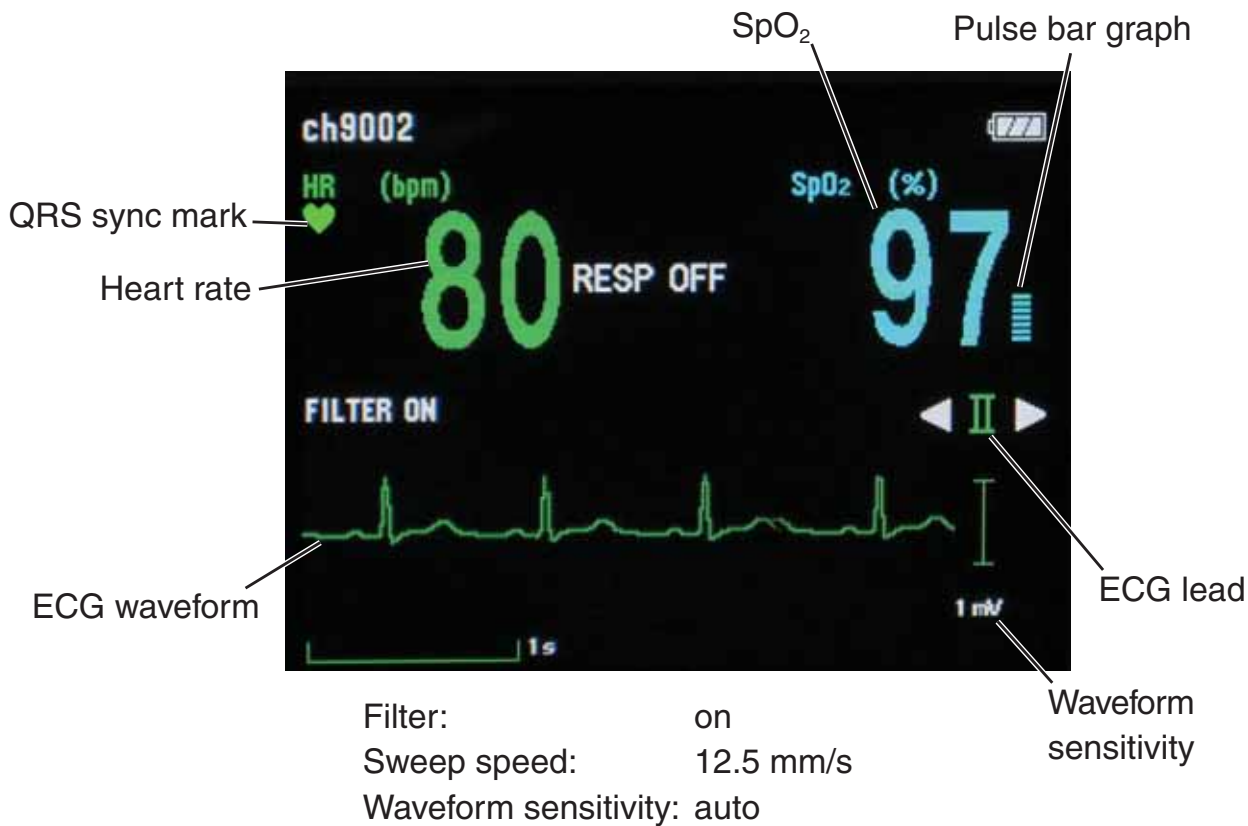

When ECG and respiration measurement is turned off

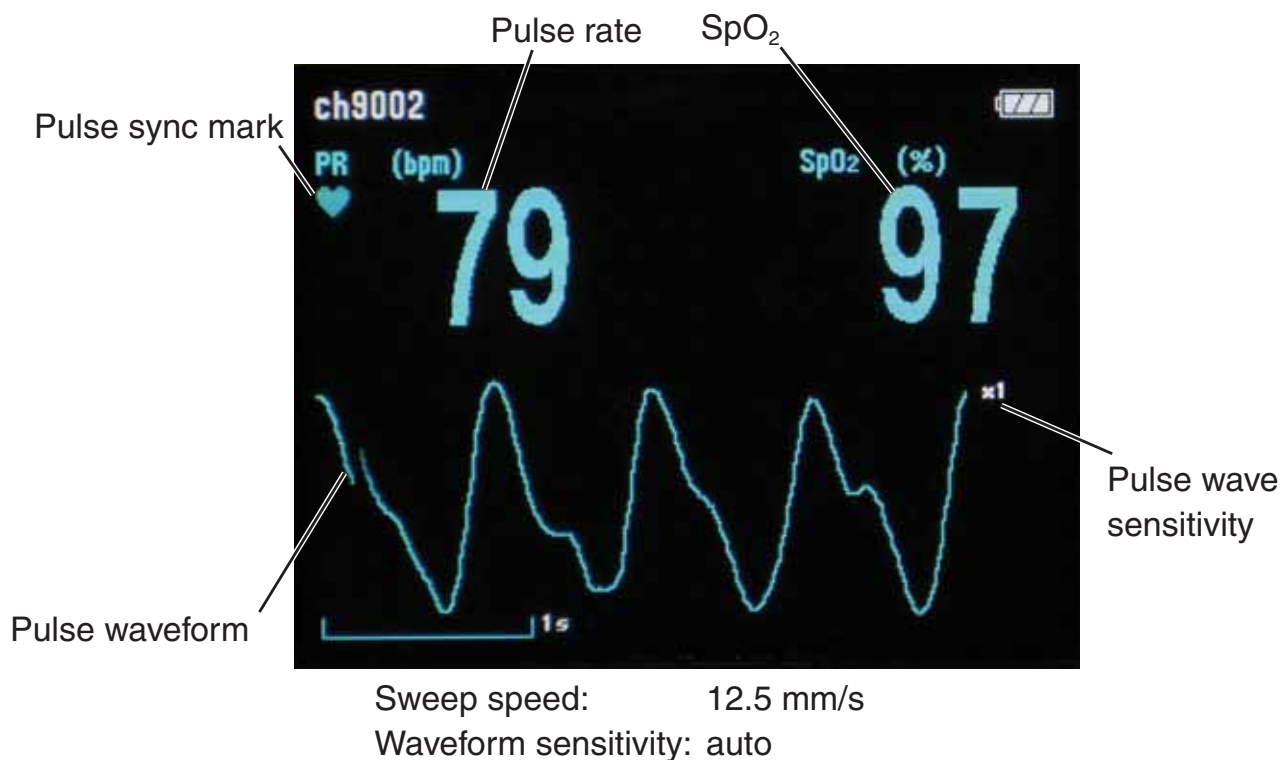



## NOTE

The pulse wave amplitude varies according to the ratio of the pulsation component to the entire transmitted IR signal. When the pulsation component ratio is 1%, the pulse wave amplitude is about 5 mm at  $\times 1$  sensitivity on the screen.

### Waveform Review Screen

ECG full disclosure for up to 10 minutes can be saved and reviewed. When ECG measurement is turned off and SpO<sub>2</sub> is monitored, the pulse waveform is saved.

When ECG lead is changed on the numeric and waveform screen, the ECG full disclosure of the changed lead is saved.

The saved data is deleted when the transmitter is turned off.

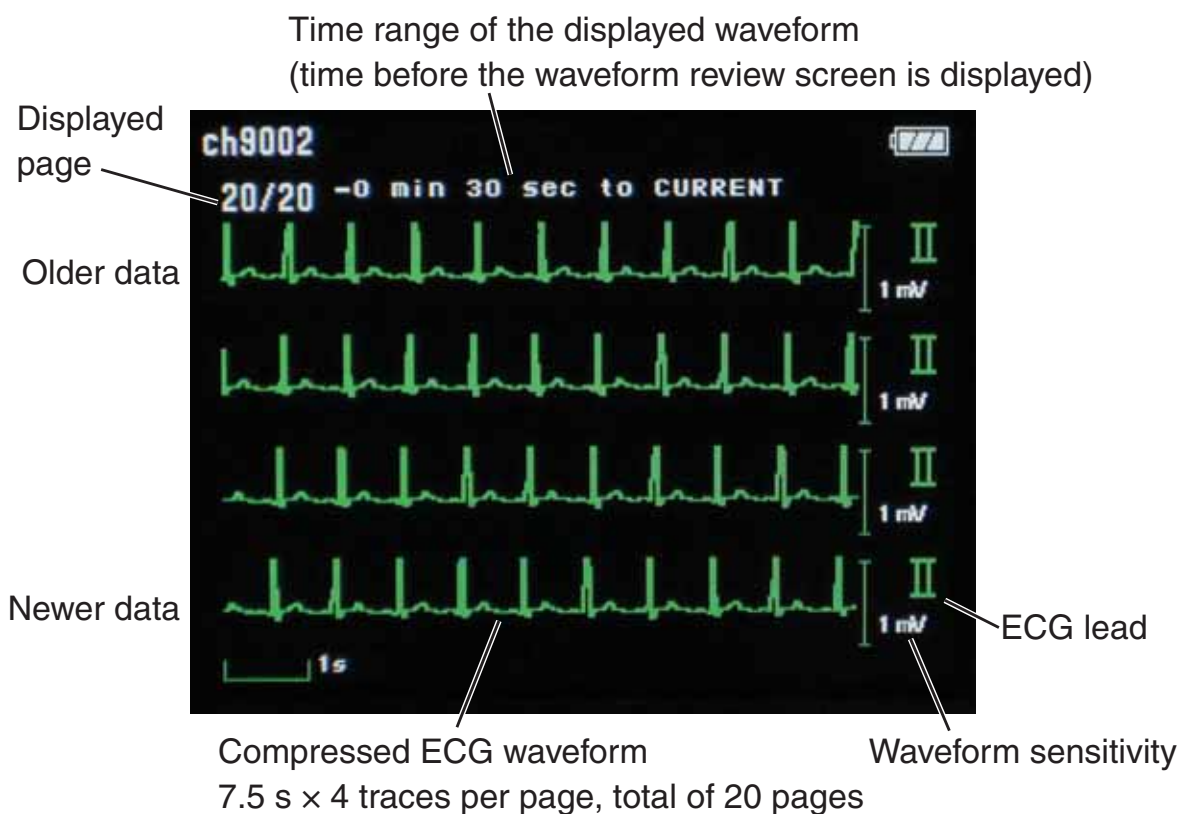

To scroll the waveform, press the **←** or **→** key. The waveform is scrolled by 30 seconds.



## Numeric Review Screen

Numeric data of heart rate (or pulse rate when ECG is turned off), SpO<sub>2</sub> and respiration rate for up to 10 minutes are saved at 1 minute intervals.

The saved data is deleted when the transmitter is turned off.

	HR (bpm)	SpO <sub>2</sub> (%)	RR (/min)
Older data			
-10[min]	80	97	20
- 9[min]	80	97	20
- 8[min]	80	97	20
- 7[min]	80	97	20
Time before the numeric review screen is displayed			
- 6[min]	80	97	20
- 5[min]	80	97	20
- 4[min]	80	97	20
- 3[min]	80	97	20
- 2[min]	80	97	20
Newer data			
- 1[min]	80	97	20

## Display Off

The display can be turned off any time. To turn off the display, press the Screen key several times until the following screen appears then wait 5 seconds.

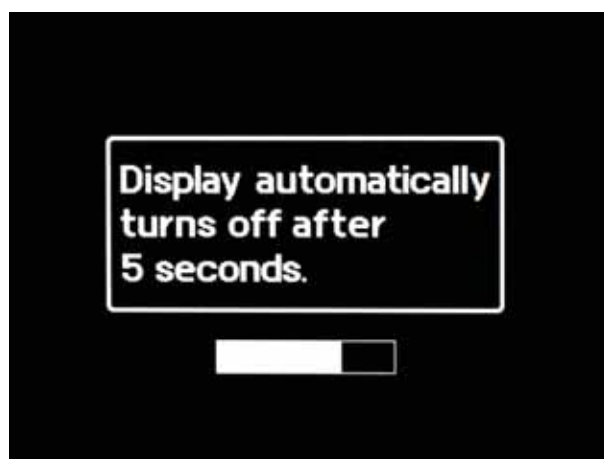

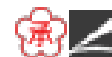

## Basic Monitoring Operation

### Using the Function Key

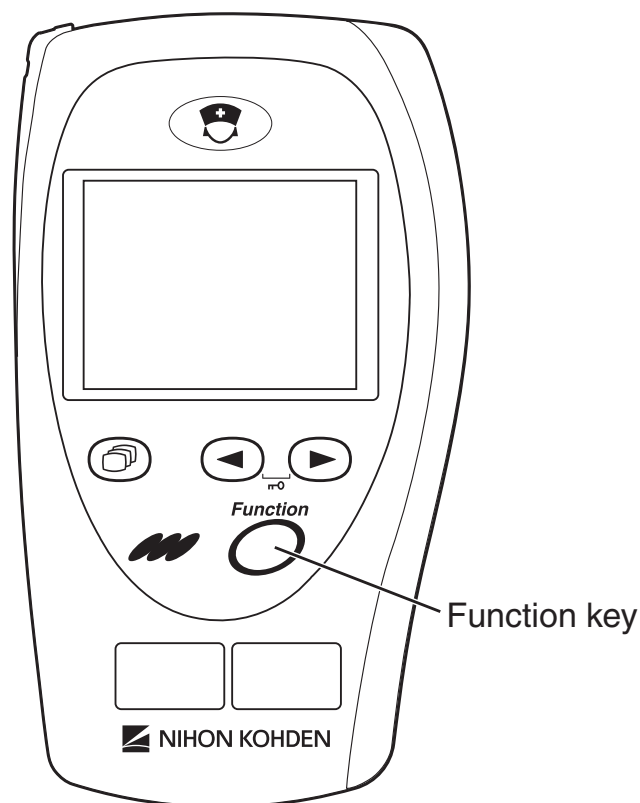

One of the following functions can be assigned to the Function key on the SYSTEM SETUP screen. Refer to the “Changing SYSTEM SETUP Settings” section.

**SUSPEND ALARM:** Suspends alarms on the receiving monitor before they occur for 2 minutes.

**PAUSE:** Pauses monitoring on the transmitter and receiving monitor.

**CONFIRM:** Transmits the signal that the patient is confirmed and displays the “PATIENT CONFIRMED” message on the transmitter.

#### NOTE

To use the Function key for PAUSE or CONFIRM, you must set “PROTOCOL” on the SYSTEM SETUP screen of the transmitter to 51 and the receiving monitor must be able to receive protocol 51. To use protocol 51, the ORG-9100A/ORG-9110A multiple patient receiver software version 03-03 or later is required.



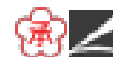

## Suspending Alarms on the Receiving Monitor

When the FUNCTION KEY is set to “SUSPEND ALARM” or “SUSPEND ALARM & PAUSE” on the SYSTEM SETUP screen, alarms can be suspended for 2 minutes on the receiving monitor before they occur.

To suspend alarms:

1. Press the Function key. The “Suspend alarms” confirmation screen appears.



2. Press the  key to suspend alarms.

To cancel suspending alarms and return to the previous screen, press the Screen key.

When the alarms are suspended, the “ALARMS SUSPENDED” message and alarm suspended icon with the remaining minutes in alarm suspension appear on the transmitter screen.

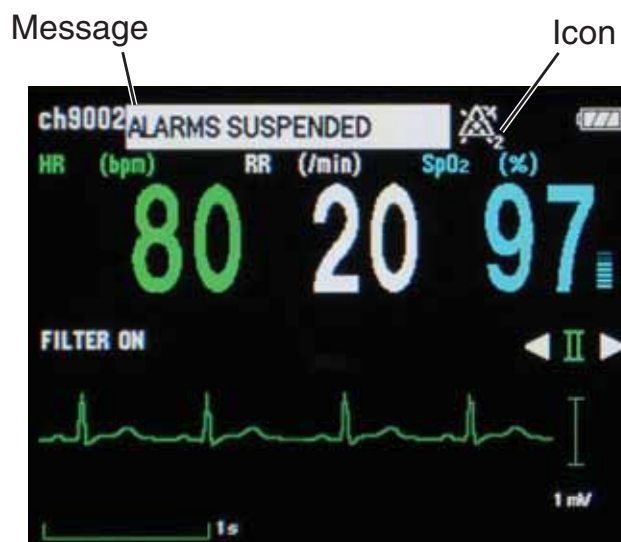





To cancel suspending alarms during 2 minute alarm suspension:

1. Press the Function key while the “ALARMS SUSPENDED” message is displayed. The confirmation screen appears.



2. Press the  key to cancel alarm suspension.  
Press the Screen key to not cancel alarm suspension.

## Pause Monitoring

When the FUNCTION KEY is set to “SUSPEND ALARM & PAUSE” on the SYSTEM SETUP screen, you can pause monitoring on the receiving monitor from the transmitter when the patient cannot be monitored, such as during X-ray examination.

### NOTE

To use the Function key for PAUSE, you must set “PROTOCOL” on the SYSTEM SETUP screen of the transmitter to 51 and the receiving monitor must be able to receive protocol 51. To use protocol 51, the ORG-9100A/ORG-9110A multiple patient receiver software version 03-03 or later is required.

Monitoring on the receiving monitor resumes when one of the following conditions is met.

When OFF is selected for “AUTO RESUME AFTER PAUSE” on the SYSTEM SETUP screen, monitoring does not automatically resume.

- Heart rate is properly monitored on the transmitter for the interval selected for “AUTO RESUME AFTER PAUSE”.
- SpO<sub>2</sub> is properly monitored on the transmitter for the interval selected for “AUTO RESUME AFTER PAUSE”.



To pause monitoring:

1. Press the Function key. The “Suspend alarms” confirmation screen appears.



2. Press the Function key for 3 seconds to display the “Pause monitoring” confirmation screen.



3. Press the key to pause monitoring.  
To cancel pause monitoring, press the Screen key.
4. Wait about 5 seconds until the “Turn power off” screen appears.



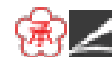

## 5. Turn off the transmitter.

If the transmitter is not turned off and monitoring continues for the interval set for “AUTO RESUME AFTER PAUSE” on the SYSTEM SETUP screen, pause monitoring is cancelled and monitoring continues.

## Resume Monitoring after Pause

To resume monitoring after pause, check that the electrodes, electrode leads and probe are attached to the patient then turn on the transmitter.

## Confirming Patient

When the FUNCTION KEY is set to “CONFIRM” on the SYSTEM SETUP screen, pressing the Function key sends a signal to the receiving monitor to indicate that the patient or patient condition is confirmed by medical staff.





## Turning the Display Off

The display can be turned off any time. To turn off the display, press the Screen key several times until the following screen appears then wait 5 seconds.

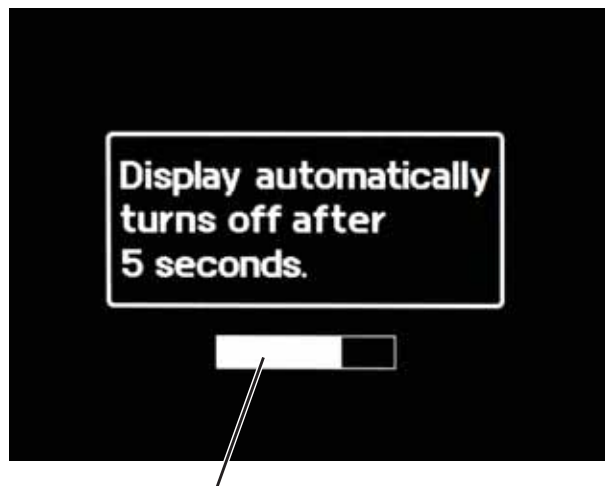

5 second time bar until the display turns off

## Turning the Display On after It was Turned Off

Press the Screen key. The numeric and waveform screen appears. If the screen is turned off on the “Keys locked” screen, the “Keys locked” screen appears.

When the Screen key is pressed within 5 minutes after the display was turned off, the previous screen appears.



## ECG and Respiration Monitoring

When the electrodes are attached and the ECG leads are connected, the heart rate, ECG waveform, respiration rate and respiration waveform appear on the receiving monitor. Refer to the operator's manual of the receiving monitor for details.

When 6 leads are used on this transmitter, up to 8 leads (I, II, III, aVR, aVL, aVF, Va and Vb) of ECG waveforms can be displayed on the receiving monitor. The heart rate is also measured.

When 3 leads are used, one channel ECG waveform of lead II can be displayed on the receiving monitor. Refer to the operator's manual of the monitor for details.

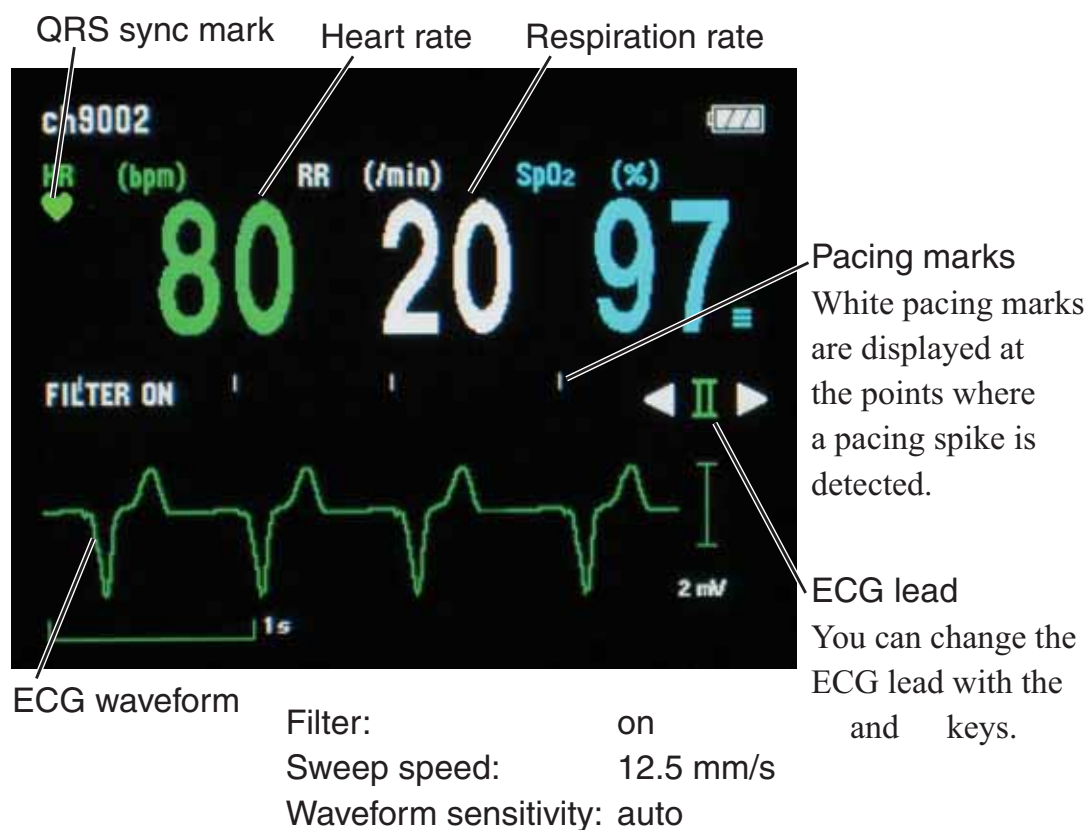

### CAUTION

Turn off the power of mobile phones, small wireless devices and other devices which produce strong electromagnetic interference around a patient (except for devices allowed by the hospital administrator). Radio waves from devices such as mobile phones or small wireless devices may be mistaken as pulse waves or respiration waves and the displayed data may be incorrect.

### NOTE

- ECG cannot be monitored on a neonate using this transmitter.
- When performing defibrillation, set the hum filter to ON on the receiving monitor. The waveform recovery may become slow due to electrode polarization when the hum filter is set to OFF.

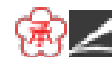

### Use with a Pacemaker

When monitoring a pacemaker patient, the transmitter detects pacemaker pulse and rejects the pacemaker pulse from the heart rate count.

#### WARNING

##### Interaction Between Minute Ventilation Rate-Adaptive Pacemakers and Cardiac Monitoring and Diagnostic Equipment\*

The bioelectric impedance measurement sensor of a minute ventilation rate-adaptive implantable pacemaker may be affected by transmitter which is connected to the same patient. If this occurs, the pacemaker may pace at its maximum rate and the transmitter may give incorrect data to the monitor. If this occurs, disconnect the electrode leads from the patient or change the setting on the pacemaker by referring to the pacemaker's manual. For more details, contact your pacemaker representative or Nihon Kohden representative.

- \* Minute ventilation is sensed in rate-adaptive pacemakers by a technology known as bioelectric impedance measurement (BIM). Many medical devices in addition to pacemakers use this technology. When one of these devices is used on a patient with an active, minute ventilation rate-adaptive pacemaker, the pacemaker may erroneously interpret the mixture of BIM signals created in the patient, resulting in an elevated pacing rate.

For more information, see the FDA web site.

<http://www.fda.gov/cdrh/safety.html>

#### WARNING

The transmitter detects the pacemaker pulse and rejects the pacemaker pulse from the heart rate count. However, all of the pacemaker pulse might not be rejected. If the pacemaker pulse is not rejected, the pacemaker pulse is detected as QRS and false heart rate may be indicated. Keep pacemaker patients under close observation.

- \* For the pacemaker pulse rejection capability of ZM-520PA/521PA/530PA/531PA transmitter refer to the "Specifications - ECG" section.

#### WARNING

The pacemaker pulse can be overlooked or detected as QRS. You cannot confirm the pacemaker operation only from the detected pacemaker pulse.

#### NOTE

- If an electric blanket is used and incorrect heart rate is displayed on the monitor, turn off the pacing spike detection on the monitor.

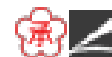

- Turn the pacing spike detection to ON on the receiving monitor when monitoring a pacemaker patient. Pacing pulse is detected by the transmitter and transmitted to the monitor. If the pacing spike detection is turned OFF, QRS and pacemaker spike might not be distinguished and pacemaker failure might not be recognized.

### Use with an Electrosurgical Unit

For use with an electrosurgical unit (ESU), this transmitter has a circuit to protect the patient from skin burn and to reduce ESU interference on the ECG waveform. However, the effectiveness of this circuit depends on electrode position and transmitter setup. With an ESU, pay attention to the following points.

### WARNING

When the transmitter is used with an electrosurgical unit (ESU), firmly attach the entire area of the ESU return plate. Otherwise, the current from the ESU flows into the electrodes of the transmitter, causing electrical burn where the electrodes are attached. For details, refer to the ESU manual.

### NOTE

Noise generated from an electrosurgical unit may interfere on an ECG waveform, but will not damage it.

- Measure with 3-electrode lead  
Use the minimum number of electrodes. Use new electrodes.
- Minimize noise
  1. Select an ECG lead where the active ECG electrodes are located as far from the incision as possible.
  2. Position the + and – electrodes as close as possible.
  3. Select the leads where the angle ( $\theta$ ) between the active electrodes and the incision is as small as possible.
  4. Set the electrosurgical return plate as close to the incision as possible.

As far as possible from electrode and  
as near as possible to incision.

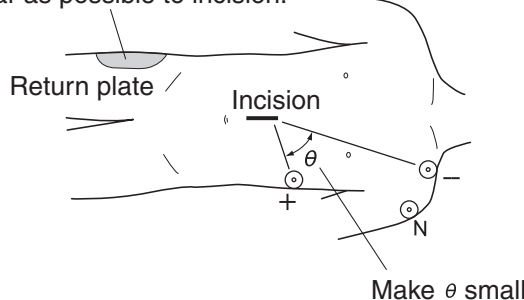



## Turning ECG Measurement On/Off

ECG measurement can be turned on or off on the PARAMETER SETUP screen. When electrodes are attached to the patient and ECG leads are connected, ECG monitoring starts even when ECG is turned off.

### When PROTOCOL on the SYSTEM SETUP screen is set to 51:

ECG measurement on the receiving monitor is automatically set to off.

## NOTE

ECG measurement on the transmitter cannot be turned on or off from the receiving monitor.

### When PROTOCOL on the SYSTEM SETUP screen is set to 41:

If ECG measurement is turned off on the transmitter, ECG measurement on the receiving monitor must also be turned off.

## Turning Respiration Measurement On/Off

Respiration measurement can be turned on or off on the PARAMETER SETUP screen. If respiration measurement is turned off, respiration measurement on the receiving monitor is also turned off.

## Electrode Detachment

In the following conditions, the “CHECK ELECTRODES” message is displayed on the transmitter and receiving monitor.

- Electrode is detached from skin.
- Electrode lead is disconnected from the electrode.
- Polarization voltage between the electrode and skin is excessively high.

In these cases, check the cause and if necessary, replace electrodes with new ones.

## CAUTION

When the “ELECTRODE OFF” or “CHECK ELECTRODES” message is displayed on the receiving monitor, ECG is not monitored properly and the ECG alarm does not function. Check the electrode, electrode leads, and if necessary, replace with new ones.



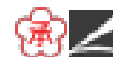

## SpO<sub>2</sub> Monitoring

The SpO<sub>2</sub> monitoring is only available on the ZM-530PA/531PA transmitter.

When monitoring starts, SpO<sub>2</sub> and the pulse waveform are sent to the receiving monitor and SpO<sub>2</sub> and the pulse level bar graph are displayed on the transmitter screen. When ECG is not measured, the pulse waveform and pulse rate are also displayed.

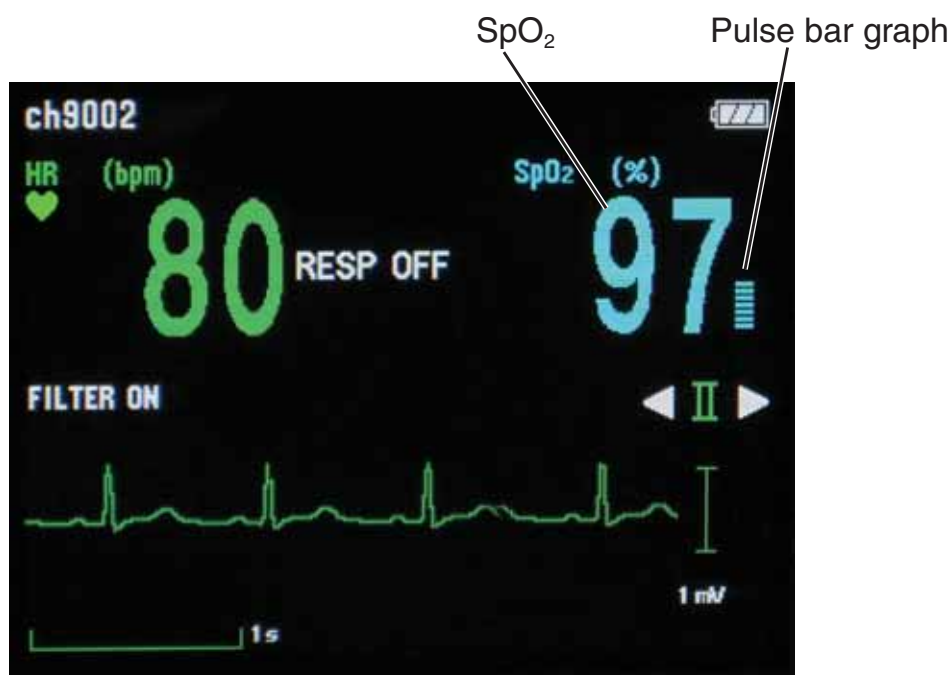

### NOTE

During SpO<sub>2</sub> monitoring, the transmitter constantly checks the light intensity of the probe and adjusts the light intensity to maintain optimum measurement condition. During adjustment, the pulse wave becomes flat for about 0.5 seconds.



**WARNING**

SpO<sub>2</sub> measurement may be incorrect in the following cases.

- When the patient's carboxyhemoglobin or methemoglobin increases abnormally.
- When dye is injected in the blood.
- When using an electrosurgical unit.
- During CPR.
- When measuring at a site with venous pulse.
- When there is body movement.
- When the pulse wave is small (insufficient peripheral circulation).

**WARNING**

Check the circulation condition by observing the skin color at the measurement site and pulse waveform. Change the measurement site every 8 hours for disposable probes and every 4 hours for reusable probes (every 8 hours for TL-631T series probe). The skin temperature may increase at the attached site by 2 or 3°C (4 or 5°F) and cause a burn or pressure necrosis. When using the probe on the following patients, take extreme care and change the measurement site more frequently according to symptoms and degree.

- Patient with a fever
- Patient with insufficient peripheral circulation
- Neonate or low birth weight infant with delicate skin

**WARNING**

When monitoring SpO<sub>2</sub> of a patient who is receiving photodynamic therapy, the light from the finger probe sensor may cause a burn. Photodynamic therapy uses a photosensitizing agent that has a side effect of photosensitivity.

**WARNING**

When not monitoring SpO<sub>2</sub>, disconnect the SpO<sub>2</sub> cable from the transmitter. Otherwise, noise from the probe sensor may interfere and incorrect data is displayed on the screen.

The SpO<sub>2</sub> probe manufactured by Nihon Kohden have two wavelengths with peaks in the range of 650 and 950 nm. The maximum light intensity is less than 5.5 mW.

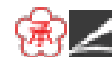
**CAUTION**

Turn off the power of mobile phones, small wireless devices and other devices which produce strong electromagnetic interference around a patient (except for devices allowed by the hospital administrator). Radio waves from devices such as mobile phones or small wireless devices may be mistaken as pulse waves or respiration waves and the displayed data may be incorrect.

**CAUTION**

Failure to follow these instructions may cause cable discontinuity, short circuit, skin burn on the patient from the probe temperature increase due to the short circuit of the probe cable, and incorrect measurement data. If the probe is broken, replace it with a new one.

- Do not immerse any part of the probe cable other than the disposable probe in chemical solutions or water.
- Do not pull or bend the probe cable.
- Do not let caster feet run over the probe cable.

**CAUTION**

Normal external light does not affect monitoring but strong light such as a surgical light or sunlight may affect monitoring. If affected, cover the measuring site with a blanket.

**CAUTION**

When the probe is attached on an appropriate site with sufficient circulation and the error message confirming the probe attachment repeatedly appears, the probe may be deteriorated. Replace it with a new one.

**CAUTION**

When a message indicates a faulty probe, stop monitoring and replace the probe with a new one.

**CAUTION**

While a patient is on medication which causes vasodilation, the pulse waveform may change and in rare cases the SpO<sub>2</sub> value might not be displayed.

**CAUTION**

Do not attach the probe to the same limb that is used for NIBP measurement or an IBP catheter. The SpO<sub>2</sub> measurement may be incorrect.







### NOTE

- In order to maintain sufficient blood circulation, keep the measurement site warm by covering it with a blanket or something similar. Warming the site is effective, especially for a patient with a small pulse amplitude.
- When monitoring a patient who has an IABP and SpO<sub>2</sub> cannot be measured, monitor the patient on a wired monitor. If the monitor has a sensitivity mode, set the mode to “MAX”.



## Indications and Messages

### Indication

Indication	Cause	Countermeasure
	Batteries are fully charged.	—
	Batteries are getting low.	
	Batteries are low.	
	Batteries are almost empty.	Replace batteries.
	Alarms on the receiving monitor were suspended by pressing the Function key on the transmitter.	Alarms resume when the suspend interval elapses. To cancel alarm suspension, press the Function key again.

### Messages

When PROTOCOL on the SYSTEM SETUP screen is set to 51, all messages are transmitted.

When PROTOCOL is set to 41, the messages marked with \* are not transmitted.

Message	Cause	Countermeasure
ALARMS SUSPENDED	Alarms on the receiving monitor is suspended by pressing the Function key on the transmitter.	Alarms resume when the 2 minute suspend interval elapses. To cancel alarm suspension, press the Function key again.
BATTERY WEAK	Dead batteries.	Replace batteries.
CANNOT DETECT PULSE*	Poor blood circulation for measuring the SpO <sub>2</sub> value.	Check the patient condition, probe attachment or change the attachment site.
	The probe is attached too tightly and is obstructing the blood circulation.	Reattach the probe.
	The probe is not attached to the patient properly.	Attach the probe to the patient properly.
	“LIGHT INTERFERENCE”, “CHECK PROBE SITE” or “DETECTING PULSE” message is displayed for more than 30 seconds.	Refer to the cause and countermeasure for each message in this Messages table and remove the cause.

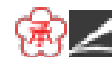

Message	Cause	Countermeasure
CANNOT MEASURE*	Contact between the disposable electrode and skin becomes poor.	Replace electrodes with new ones immediately.
CHECK ELECTRODES	Electrode lead is disconnected from the electrode.	Firmly connect the electrode lead to the electrode.
	Electrode lead is disconnected from the transmitter.	Firmly connect the electrode lead to the transmitter.
	Electrode lead discontinuity.	Replace the electrode lead with a new one.
	Electrode is not firmly attached to the skin.	Replace the electrode with a new one.
	Polarization voltage is abnormally high.	
CHECK PROBE	The probe is not attached to the patient properly.	Attach the probe to the patient properly.
	The probe is not attached at the appropriate site.	Attach the probe to an appropriate site indicated in the probe manual.
	The probe is disconnected from the transmitter.	Connect the probe cable to the transmitter.
	The probe is past its expiration date.	Replace the probe with a new one.
CHECK PROBE SITE*	The probe is not attached at the appropriate site.	Attach the probe to an appropriate site indicated in the probe manual.
	The probe is deteriorated.	Replace the probe with a new one.
	The probe is past its expiration date.	
DETECTING PULSE	Searching for the correct pulse wave for SpO <sub>2</sub> monitoring.	Wait until the pulse wave is detected.
	The SpO <sub>2</sub> value cannot be obtained because the waveform is unstable.	Attach the probe to the patient properly.
	The probe is not attached to the patient properly.	
LIGHT INTERFERENCE	The SpO <sub>2</sub> measurement site is under fluorescent light, surgical light, sunlight, or other strong light.	Cover the measurement site with a blanket or cloth.
	Considerable body movement.	When the message is displayed frequently, check the patient condition and, if necessary, change the attachment site.
	The probe is not attached to the patient properly.	

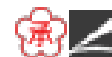

<b>Message</b>	<b>Cause</b>	<b>Countermeasure</b>
PATIENT CONFIRMED*	Function key is pressed and the "PATIENT CONFIRMED" signal is transmitted to the receiving monitor. (When "PATIENT" is assigned as the function for the Function key on the SYSTEM SETUP screen.)	—
PROBE FAILURE*	The probe is past its expiration date.	Replace the probe with a new one.
	Probe is damaged or short-circuited.	
	Transmitter failure.	Contact your Nihon Kohden representative.
SpO <sub>2</sub> MODULE ERROR*	Transmitter failure.	Contact your Nihon Kohden representative.
SYS OUT OF RANGE	The maximum blood pressure cannot be measured even when the cuff inflation pressure exceeded 280 mmHg when using adult cuff.	Measure by palpation or auscultation.
WEAK PULSE*	Poor peripheral circulation.	Check the patient condition and change the probe attachment site.
	The probe is attached too tightly and is obstructing the blood circulation.	Check the probe attachment condition and if necessary, reattach the probe.
RESP OFF	"RESP MEASUREMENT" on the PARAMETER SETUP screen is set to OFF.	If respiration monitoring is necessary, set "RESP MEASUREMENT" to ON.

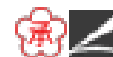

## Message Display Priority

When more than one message condition occurs on the transmitter, only the message with the highest priority is displayed.

Priority	Message
Highest ↑ ↓ Lowest	PATIENT CONFIRMED
	PROBE FAILURE
	CHECK ELECTRODES
	SpO <sub>2</sub> MODULE ERROR
	CHECK PROBE
	CHECK PROBE SITE
	CANNOT DETECT PULSE
	LIGHT INTERFERENCE
	CANNOT MEASURE
	DETECTING PULSE
	WEAK PULSE
	ALARMS SUSPENDED
	BATTERY WEAK





## Troubleshooting

If a problem occurs, use the following to find and fix it. If the problem still remains after checking the following, contact your Nihon Kohden representative.

### Transmitter

Problem	Cause	Countermeasure
Nothing is displayed on the LCD after turning the power on.	Batteries are not installed correctly. The battery polarity is wrong.	Install the batteries correctly.
	Batteries are completely discharged.	Replace the batteries with new ones.
LCD is difficult to see (too dark or too light).	LCD brightness is not appropriate.	Change the LCD brightness on the SYSTEM SETUP screen. Refer to the “Changing SYSTEM SETUP Settings” section.
Nothing is displayed on the receiving monitor after turning the transmitter power on.	The channel of the transmitter and monitor does not match.	Set the correct channel on the monitor.
	The software version of the multiple patient receiver or central monitor is old.	Upgrade the multiple patient receiver or central monitor software to receive signal from the transmitter. Contact your Nihon Kohden representative.
	Protocol on the transmitter and monitor does not match.	Set the same protocol on the transmitter and monitor.
	Protocol on the transmitter is set to 51 but the monitor cannot receive protocol 51.	Set the protocol on the transmitter to 41. Refer to the “System Setup Setting List” section.



<b>Problem</b>	<b>Cause</b>	<b>Countermeasure</b>
Signal receiving condition is poor.	Another transmitter with the same channel is used nearby.	Turn the transmitter power off. If the monitor still receives a signal, there is a high probability that another transmitter of the same channel is used nearby. Follow the instruction of your channel administrator and use another transmitter with a different channel.
	Signals of another patient are mixing.	Follow the instructions of your channel administrator and use another transmitter of a different channel.
	The transmitter is damaged.	Contact your Nihon Kohden representative.

## ECG/Respiration

<b>Problem</b>	<b>Cause</b>	<b>Countermeasure</b>
The heart rate is unstable.	Pacing detection setting on the monitor is not correct.	Turn off the pacing detection setting on the receiving monitor. When monitoring a pacemaker patient, turn on pacing detection.
The “CHECK ELECTRODES” message appears on the receiving monitor.	Electrode lead is disconnected from the electrode.	Firmly connect the electrode lead to the electrode.
	Electrode lead discontinuity.	Replace the electrode lead with a new one.
	Electrode is not firmly attached to the skin.	Replace the electrode with a new one.
	Polarization voltage is abnormally high.	Use Nihon Kohden specified electrodes.
ECG baseline is thick (AC hum).	The gel on the electrode is dried out.	Replace the electrode with a new one.
	The gel on the electrode is coming off.	
	An electric blanket is used.	Cover the blanket with a shield cover.
	The hum filter is set to OFF on the monitor.	Set the filter to ON.

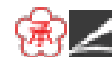

<b>Problem</b>	<b>Cause</b>	<b>Countermeasure</b>
The heart rate of a patient who is using an electric blanket is unstable on the receiving monitor.	Pacing pulse detection is turned ON on the receiving monitor.	Turn OFF the pacing pulse detection on the receiving monitor.
No heart rate or ECG is displayed.	“ECG MEASUREMENT” on the PARAMETER SETUP screen is set to OFF.	If ECG monitoring is necessary, set “ECG MEASUREMENT” to ON.
Respiration waveform measurement is unstable.	The gel on the electrode is dried out.	Replace the electrode with a new one.
	The gel on the electrode is coming off.	
No respiration rate is displayed.	“RESP MEASUREMENT” on the PARAMETER SETUP screen is set to OFF.	If respiration monitoring is necessary, set “RESP MEASUREMENT” to ON.

## SpO<sub>2</sub>

<b>Problem</b>	<b>Cause</b>	<b>Countermeasure</b>
SpO <sub>2</sub> data is unstable and not reliable.	The probe size is not appropriate for the patient.	Use the appropriate probe for the patient.
	Probe attachment condition is poor. The probe is partly detached from the skin. External light is entering the probe.	Firmly attach the probe according to the procedure in the probe operator's manual.
	Measurement site is dirty. Patient is wearing nail polish.	Remove dirt and nail polish.
	The probe is attached to the same limb that is used for NIBP measurement.	Attach the probe to the opposite limb. Avoid a site where blood circulation condition changes greatly.



## Maintenance

To use the transmitter in safe and optimum condition, perform maintenance check every six months.

The following units are necessary for some checking items.

- AX-400G Vital Sign Simulator
- AX-300T SpO<sub>2</sub> Checker
- Receiving monitor

### CAUTION

Never disassemble or repair the transmitter. If there is any problem with the transmitter, contact your Nihon Kohden representative.

### NOTE

- The measurement accuracy of the above units must be managed to perform accurate maintenance check.
- For details on the operation of the above units, refer to the manuals provided with these units.

A maintenance check sheet is provided at the end of this section. Make a copy of this check sheet before performing maintenance check.

### 1. External Check

- There is no damage or dirt on the outside of the transmitter.
- The battery case cover is not damaged, the spring is firmly attached and the battery case cover can be closed firmly.
- No keys are damaged.
- No electrode leads are damaged.
- There are no blood or chemicals on the transmitter.
- The springs in the battery compartment are not damaged or detached.
- Terminals in the battery case are not corroded.

### 2. Transmitter Channel

- The channel number label on the transmitter is not torn or removed.
- The channel of the transmitter matches the label.

The transmitter channel is displayed in the upper left corner of the screen. The channel number also appears on the startup screen.



Startup screen

Channel numbers



Numeric and waveform screen

### 3. Transmitting/Receiving Signal

Use the AX-400G vital sign simulator and receiving monitor.

1. Connect the vital sign simulator to the transmitter.

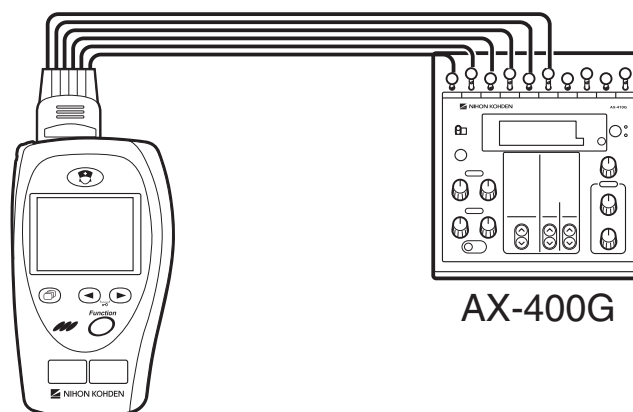

2. Place the transmitter 2 to 3 m from the receiving monitor.
3. Set the channel on the receiving monitor to the channel of the transmitter.
4. Turn on the transmitter and vital sign simulator.
5. Check that the ECG of the transmitter appears on the receiving monitor.
6. Turn off the transmitter.
7. Check that the ECG disappears from the receiving monitor.

### 4. Display

Check that there are no dots missing on the screen.

1. Turn off the transmitter.



2. While pressing the Function key, turn on the transmitter. The MENU screen appears.
3. Press the  key to move the cursor to “MANUAL CHECK” and press the Function key.



4. Press the  or  key to move the cursor to “LCD TEST” and press the Function key.



5. Each time the  key is pressed, the screen changes as below. Check that no dots are missing.

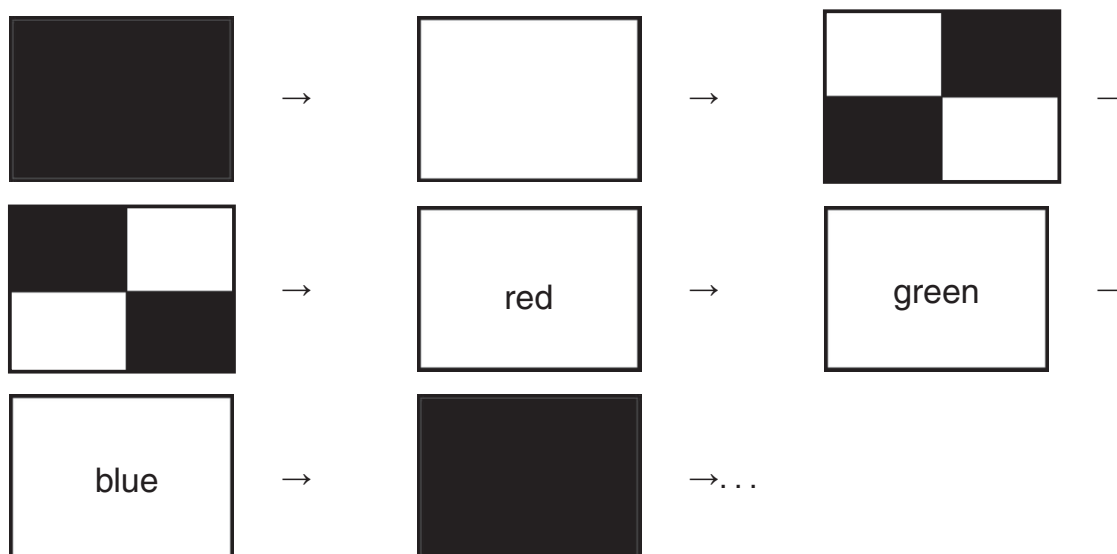

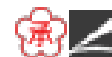



6. Press the Screen key to return to the MANUAL CHECK screen.
7. Press the Screen key again to return to the MENU screen.

## 5. Key Operation

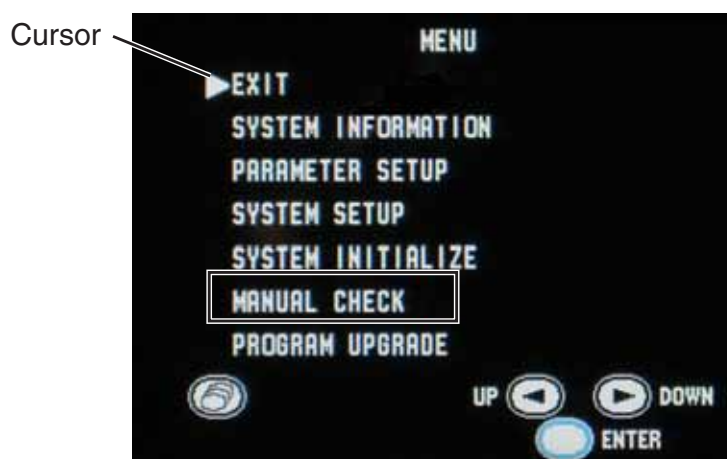
1. Turn off the transmitter.
2. While pressing the Function key, turn on the transmitter. The MENU screen appears.
3. Press the  key to move the cursor to “MANUAL CHECK” and press the Function key.



4. Press the  or  key to move the cursor to “KEY CHECK” and press the Function key.



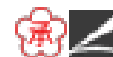

5. Press each key one at a time and check that the pressed key is highlighted on the screen.

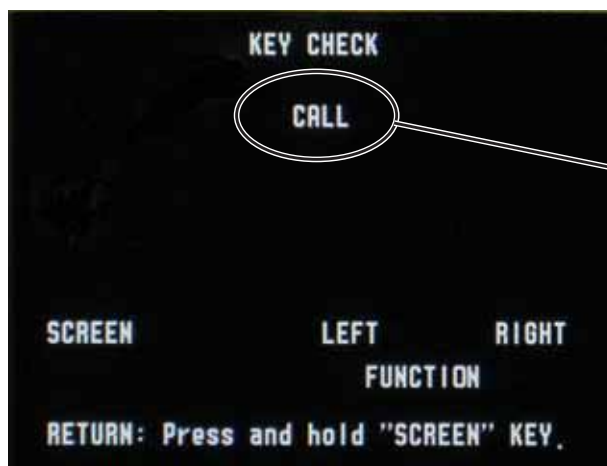

When the CALL key is pressed, the key name is highlighted.

6. After checking, press and hold the Screen key to return to the MANUAL CHECK screen.

## 6. ECG Check

1. Connect the vital sign simulator to the transmitter.

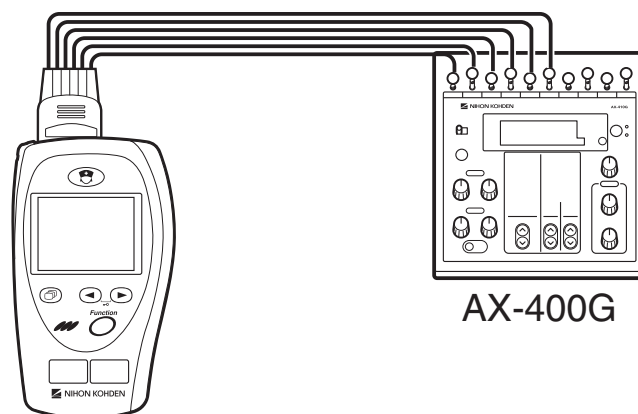

2. Place the transmitter 1 m from the receiving monitor.
3. Turn on the transmitter and vital sign simulator.
4. Check that the ECG of the transmitter appears on the receiving monitor.



## 7. Respiration Check

1. Connect the vital sign simulator to the transmitter.

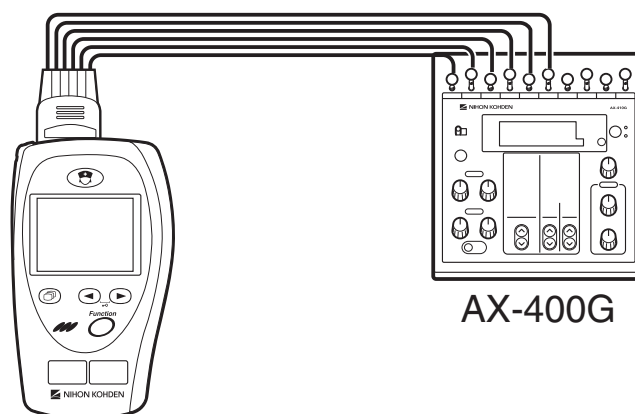

2. Place the transmitter 1 m from the receiving monitor.
3. Turn on the transmitter and vital sign simulator.
4. Check that the respiration waveform of the transmitter appears on the receiving monitor.

## 8. SpO<sub>2</sub> Check

1. Connect the SpO<sub>2</sub> checker to the transmitter.

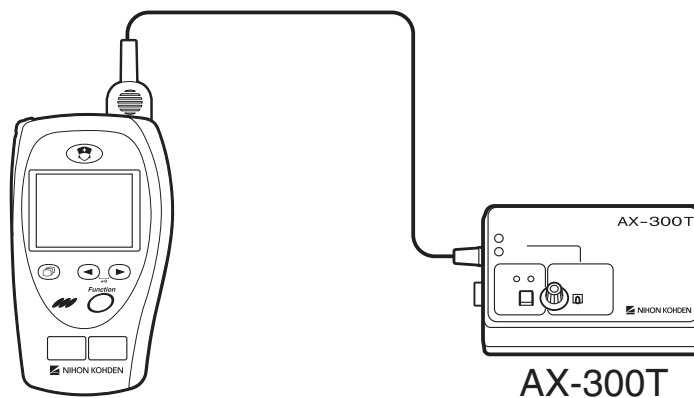

2. Place the transmitter 1 m from the receiving monitor.
3. Turn on the transmitter and SpO<sub>2</sub> checker.
4. Check that the pulse bar graph appears on the transmitter screen.



5. Check that SpO<sub>2</sub> and pulse rate on the transmitter is within the following range.

SpO <sub>2</sub> on the SpO <sub>2</sub> Checker		Range
SpO <sub>2</sub>	97%	95 to 99%SpO <sub>2</sub> (±2 digit)
	80%	78 to 82%SpO <sub>2</sub> (±2 digit)
	70%	67 to 73%SpO <sub>2</sub> (±3 digit)
Pulse rate	60 beats/min	57 to 62 beats/min (±3%/±1 beat/min)
	120 beats/min	115 to 124 beats/min (±3%/±1 beat/min)

### NOTE

The above range includes the error margin of the SpO<sub>2</sub> checker. Therefore, the range is ±1 digit outside the SpO<sub>2</sub> measuring accuracy of the transmitter in the “Specifications” section.

6. Check that the SpO<sub>2</sub> and pulse waveform of the transmitter appear on the receiving monitor.



## Maintenance Check Sheet

Hospital/Organization: \_\_\_\_\_

Service Personnel: \_\_\_\_\_

Instrument Name: Transmitter

Instrument Model: ZM-520PA/ZM-521PA/ZM-530PA/ZM-531PA

Instrument Serial Number: \_\_\_\_\_

Hardware Revision Number: \_\_\_\_\_

Software Revision Number: \_\_\_\_\_

1. External Check	OK	No
2. Transmitter Channel	OK	No
3. Transmitting/Receiving Signal	OK	No
4. Display	OK	No
5. Key Operation	OK	No
6. ECG Check	OK	No
7. Respiration Check	OK	No
8. SpO <sub>2</sub> Check	OK	No

### Overall Judgement

- OK
- Can be used but needs maintenance.
- Maintenance required. Cannot be used.



## Lifetime and Disposal

### CAUTION

Dispose of Nihon Kohden products according to your local laws and your facility's guidelines for waste disposal. Otherwise, it may affect the environment. If there is a possibility that the product may have been contaminated with infection, dispose of it as medical waste according to your local laws and your facility's guidelines for medical waste. Otherwise, it may cause infection.

## Disposing of Used Batteries

### Battery Lifetime

Replace the batteries when the battery replacement indication appears on the transmitter. When using rechargeable batteries, recharge them.

### Disposal

#### NOTE

Remove the batteries before disposing of the transmitter.

Before disposing of the batteries, check with your local solid waste officials for details in your area for proper disposal. It may be illegal to dispose of these batteries in the municipal waste stream.

## Disposing of Electrodes and SpO<sub>2</sub> Probes

Refer to the manual for each item.

## Disposing of Transmitter

Remove the batteries from the transmitter and dispose of the transmitter following your local laws for disposal.



## Cleaning, Disinfection and Sterilization

### Transmitter and Electrode Leads

#### CAUTION

This transmitter is not waterproof. If detergent or liquid spills into the transmitter, stop cleaning or disinfecting it and contact your Nihon Kohden representative. The transmitter needs to be checked for safety and function before use.

#### NOTE

The transmitter cannot be sterilized. Sterilizing the transmitter may damage it.

Before cleaning or disinfecting, remove the batteries from the transmitter. Be careful not to let any liquid get inside the transmitter.

#### Cleaning

Wipe the transmitter and electrode leads with a soft cloth moistened with ethanol for disinfection (76.9 to 81.4% by vol) or neutral detergent diluted with water. After cleaning, dry them completely.

Use cotton swab moistened with neutral detergent diluted with water to clean inside the battery compartment.

#### Disinfection

#### CAUTION

Do not immerse the electrode lead connector in liquid.

Wipe the outside surface of the transmitter and electrode lead with a non-abrasive cloth moistened with any of the disinfectants listed below. For details on the disinfectants, refer to the instruction provided with the disinfectants. Use the recommended concentration.

<u>Disinfectant</u>	<u>Concentration (%)</u>
Glutaraldehyde solution	2.0
Alkyldiaminoethylglycine hydrochloride	0.5
Benzalkonium chloride	0.2
Benzethonium chloride solution	0.2
Chlorhexidine gluconate solution	0.5
Phtharal	0.55
Phenol	1.56



## SpO<sub>2</sub> Probe

Refer to the probe manual.

### Periodic Replacement Schedule

To maintain the performance of the instrument, the following part must be periodically replaced.

Name	Code no.	Expected life span
Silicon seal (for battery case cover)	6114-918705	1 year

### Repair Parts Availability Policy

Nihon Kohden Corporation (NKC) shall stock repair parts (parts necessary to maintain the performance of the instrument) for a period of 8 years from the date of delivery. In that period NKC or its authorized agents will repair the instrument. This period may be shorter than 8 years if a board or part necessary for the faulty section is not available.

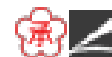

## Specifications

### ZM-520PA/530PA

#### Measuring Parameters

Measuring waveforms:	ECG, respiration in impedance method, pulse
Measuring numeric data:	Heart rate, respiration rate, SpO <sub>2</sub> , pulse rate

#### Transmitting Data

Waveform data:	ECG, respiration, pulse wave
Numeric data:	SpO <sub>2</sub> , pulse rate
Status information:	Battery replacement, battery level*, alarm suspended, pause monitoring*, patient confirmed*, ECG lead, pacing detection, electrode detachment, electrode impedance*, ECG off*, respiration method (impedance)*, SpO <sub>2</sub> status, respiration status*, channel ID, time constant (3.2 s), type of transmitter, transmitter code number*, transmitter serial number*

\* The items marked with \* are transmitted only when the protocol is "51".

#### Display

Display size:	2.2 inch TFT color LCD
Viewing area:	44.16 (H) × 33.12 (V) mm
Resolution:	320 (H) × 240 (V) dots

#### Displayed Data

Numeric and waveform screen:	ECG (one waveform from lead I, II, III, Va or Vb), heart rate, pulse rate, respiration rate, SpO <sub>2</sub> , message, battery level, QRS/pulse sync mark, pulse bar graph, ECG lead
Waveform review screen:	ECG or pulse wave of past 10 minutes
Numeric review screen:	Heart rate or pulse rate, respiration rate and SpO <sub>2</sub> at 1 minute interval for past 10 minutes
Check electrodes screen:	ECG for checking electrode attachment

#### ECG

##### ECG measurement

Channels:	4
Input dynamic range:	±10 mV or more
Electrode offset potential tolerance:	±500 mV or more
Input impedance:	5 MΩ or more

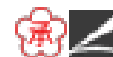

Common mode rejection ratio:	95 dB or more IEC 60601-2-27: 2005 50.102.10 complied
Pacing pulse detection:	amplitude $\pm 2$ to 700 mV, duration 0.1 to 2 ms IEC 60601-2-27: 2005 complied Based upon pacemaker pulse rejection capability
Defibrillation-proof:	ECG input protected against 400 Ws/DC 5 kV IEC 60601-2-27 17.101 complied
ECG recovery time after defibrillation:	within 10 s
Electrode condition:	Displays CHECK ELECTRODES message
Tall T-wave rejection capability:	Complies with the heights of T-waves from 0 to 1.2 mV IEC 60601-2-27: 2005 50.102.17 complied
Heart rate averaging:	Calculated by using the most recent 8 beats.
Heart rate meter accuracy and response to irregular rhythm:	Ventricular bigeminy (Test waveform name: aami3a*): 80 bpm Slow alternating ventricular bigeminy (Test waveform name: aami3b*): 60 bpm Rapid alternating ventricular bigeminy (Test waveform name: aami3c*): 108 bpm Bidirectional systoles (Test waveform name: aami3d*): 88 bpm * The test waveforms can be download at <a href="http://www.physionet.org">http://www.physionet.org</a>
Response time of heart rate meter to change in heart rate:	HR change from 80 to 120 bpm: 4 to 8 seconds HR change from 80 to 40 bpm: 11 to 15 seconds
Pacemaker pulse rejection capability, without overshoot:	Complies with the amplitudes of pacemaker pulses $\pm 2$ to $\pm 700$ mV and widths 0.1 to 2 ms (specified in IEC 60601-2-27: 2005 50.102.13)
Pacemaker pulse rejection capability, with overshoot:	Overshoot amplitudes and time constants of $\pm 0.12$ mV/100 ms to $\pm 2$ mV/4 ms (As defined by method B of IEC 60601-2-27: 2005 50.102.13, this corresponds to the pacemaker pulses amplitudes and widths of $\pm 4$ mV/2 ms to amplitudes $\pm 80$ mV/0.1 ms.)

### ECG display and heart rate count

Frequency characteristic:	filter on: 1 to 18 Hz, filter off: 0.05 to 60 Hz
Heart rate detection method:	Average
QRS detection:	70 to 120 ms: amplitude $\geq 0.5$ mV, rate 30 to 200 beats/min 40 to 120 ms: amplitude $\geq 0.5$ mV, rate 30 to 250 beats/min



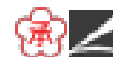

Heart rate counting range: 0, 15 to 300 beats/min  
 Heart rate counting accuracy\*:  $\pm 2$  beats/min, (0, 15 to 300 beats/min)  
 \* Essential performance of this transmitter

## Respiration Measurement

Measuring method: Impedance method  
 Measuring lead: Between R and F  
 Impedance range: 220 to 2000  $\Omega$   
 Excitor current: 54 to 93  $\mu\text{Ap-p}$ , 48 kHz  
 Respiration rate measuring accuracy\*:  $\pm 2$  counts/min (at 0 to 150 counts/min)  
 Respiration rate counting range: 0 to 150 counts/min  
 \* Essential performance of this transmitter

## SpO<sub>2</sub> Measurement (ISO 9919: 2005 compliance)

Measuring range: 0 to 100%SpO<sub>2</sub>  
 Declared range: 70 to 100%SpO<sub>2</sub>  
 Minimum display range: 1%SpO<sub>2</sub>  
 Display update cycle: Every 3 seconds  
 Measuring accuracy (rms)\*: Accuracy assurance temperature: 18 to 40°C  
 Total accuracy including probe: 80%SpO<sub>2</sub>  $\leq$  %SpO<sub>2</sub>  $\leq$  100%SpO<sub>2</sub>:  $\pm 2\%$ SpO<sub>2</sub>  
 70%SpO<sub>2</sub>  $\leq$  %SpO<sub>2</sub>  $<$  80%SpO<sub>2</sub>:  $\pm 3\%$ SpO<sub>2</sub>  
 under 70%SpO<sub>2</sub>: not specified  
 Accuracy of the transmitter: 80%SpO<sub>2</sub>  $\leq$  %SpO<sub>2</sub>  $\leq$  100%SpO<sub>2</sub>:  $\pm 1\%$ SpO<sub>2</sub>  
 50%SpO<sub>2</sub>  $\leq$  %SpO<sub>2</sub>  $<$  80%SpO<sub>2</sub>:  $\pm 2\%$ SpO<sub>2</sub>  
 under 50%SpO<sub>2</sub>: not specified  
 Pulse rate declared range: 30 to 300 bpm  
 Pulse rate display range: 30 to 300 bpm  
 Pulse rate accuracy (rms)\*:  $\pm 3\% \pm 1$  bpm

\* Essential performance of this transmitter

### NOTE

- The SpO<sub>2</sub> measuring accuracy was tested using the TL-201T, TL-260T, TL-271T and TL-631T SpO<sub>2</sub> probes. The testing was performed during induced hypoxia on healthy volunteers (Ethnicity: 10 Caucasians, 2 Africans, 1 Asian and 3 Indians), (Skin: 8 light, 4 medium, 4 dark), (Age: 21 to 34), (5 women and 11 men) under the condition of no motion. Arterial blood was sampled and measured by a CO-oximeter. The difference between SpO<sub>2</sub> measured by the SpO<sub>2</sub> probe and functional SaO<sub>2</sub> measured by a CO-oximeter was calculated using the root-mean-square (rms) method according to ISO 9919: 2005. This measurement accuracy figure represents 2/3 of all test measurements.
- A pulse oximeter tester that generates simulated signals can be used to check the difference from the design specification, but it cannot be used as a replacement for human signals for testing accuracy.



Response time:

Selectable from “Slow”, “Normal” and “Fast”.

The following graphs show the response time example when  $\text{SpO}_2$  changes  $0.6\%/s$ .

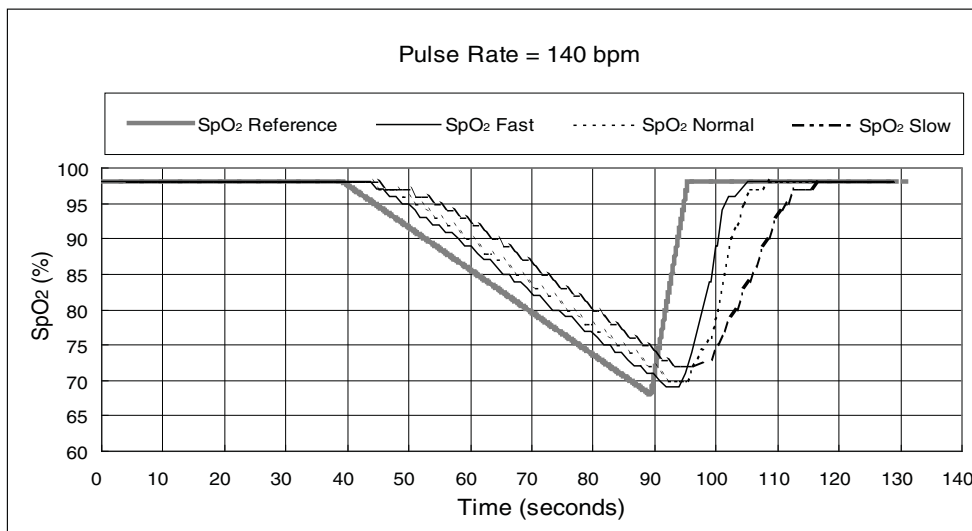
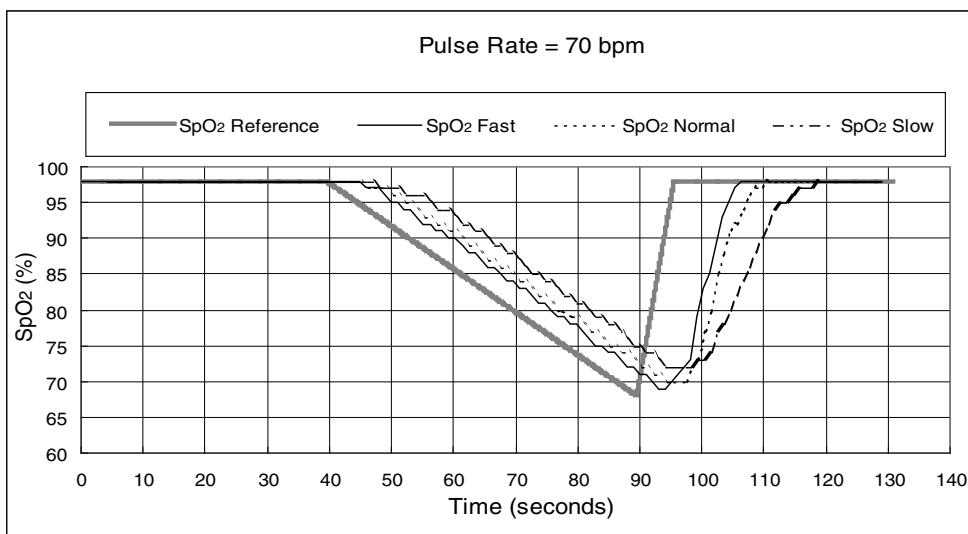

The following graph shows the response time example when pulse rate changes 10 bpm/s.

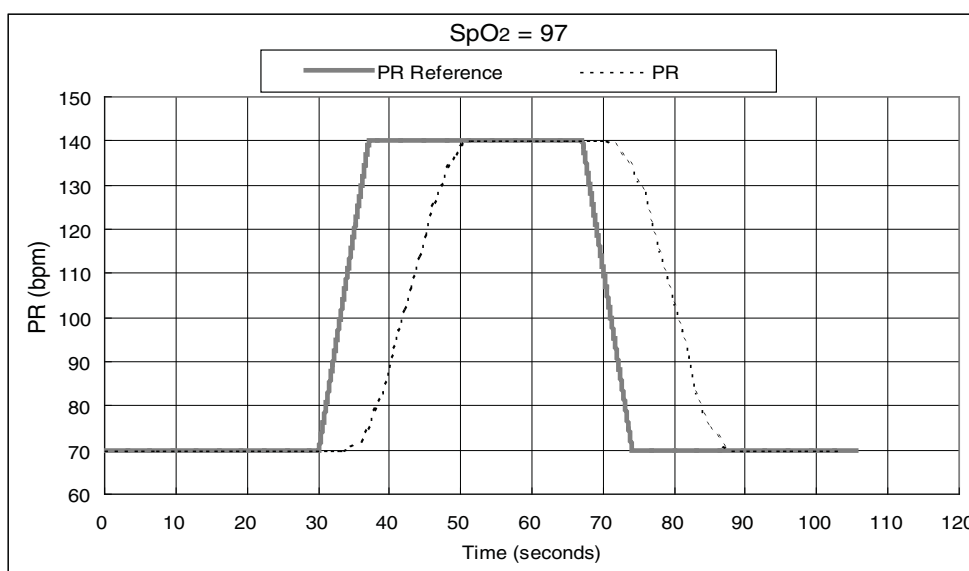

## Transmitter

FCC regulation:	FCC part 95 Subpart H Wireless Medical Telemetry Service (WMTS)
Field strength limits:	$\leq 200$ mV/m (at 3 m)
Undesired emissions:	$\leq 960$ MHz: $\leq 200$ $\mu$ V/m (at 3 m) $\geq 960$ MHz: $\leq 500$ $\mu$ V/m (at 3 m)
Antenna:	Internal
Transmission channel:	Indicated on the transmitter
Transmission frequency range:	608.0250 to 613.9750 MHz
Channel spacing:	50 kHz or 37.5 kHz (12.5 kHz when interleaved)
Modulation:	FSK (frequency shift keying)
Type of emission:	F1D
Occupied bandwidth:	12 to 18 kHz
Effective radiated power:	1.0 mW

## Power Requirements

Rated voltage:	3.0 V
Shutdown voltage:	1.4 to 1.75 V
Operating voltage:	Shutdown voltage to 3.2 V
Battery type:	Two AA (LR6) type alkaline dry cell primary batteries
Battery lifetime (with alkaline batteries, at room temperature):	
ZM-520PA:	approximately 3.5 day
ZM-530PA:	approximately 2.5 day (measuring ECG, respiration and SpO <sub>2</sub> ) approximately 3.5 day (measuring ECG and respiration)



## Dimension and Weight

Dimension:	78 W × 137 H × 36 D (mm)
Weight:	about 230 g (excluding batteries and other accessories) about 280 g (including batteries, excluding other accessories)

## Environment

### Operating environment

Temperature:	5 to 40°C (41 to 104°F)
Humidity:	30 to 85% (noncondensing)
Atmospheric pressure:	700 to 1060 hPa

### Storage and transport environment

Temperature:	-20 to +65°C (-4 to +149°F)
Humidity:	10 to 95%
Atmospheric pressure:	700 to 1060 hPa

### Water resistance

Water does not get inside the transmitter when immersed in water up to 30 cm deep for 3 minutes.

## Safety Standards

Safety standard:	CAN/CSA-C22.2 No. 601-1 M90 CAN/CSA-C22.2 No. 601-1. 1S1-94 CAN/CSA-C22.2 No. 601-1. 1B-90 CAN/CSA-C22.2 No. 60601-2-49-04 CAN/CSA-C22.2 No. 60601-2-27-06 IEC 60601-1: 1988 IEC 60601-1 Amendment 1: 1991 IEC 60601-1 Amendment 2: 1995 IEC 60601-2-27: 2005 IEC 60601-2-49: 2001 ISO 9919: 2005 UL 60601-1: 2003
------------------	---

Type of protection against electrical shock:  
INTERNALLY POWERED EQUIPMENT

Degree of protection against electrical shock:  
ECG and impedance method respiration:  
DEFIBRILLATION-PROOF TYPE CF APPLIED PART  
SpO<sub>2</sub>:  
DEFIBRILLATION-PROOF TYPE BF APPLIED  
PART

Degree of protection against harmful ingress of water:  
IPX0 (non-protected)

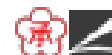

Degree of safety of application in the presence of a FLAMMABLE ANAESTHETIC MIXTURE WITH AIR, OR WITH OXYGEN OR NITROUS OXIDE:

Equipment not suitable for use in the presence of  
FLAMMABLE ANAESTHETIC MIXTURE WITH  
AIR, OR WITH OXYGEN OR NITROUS OXIDE  
CONTINUOUS OPERATION

Mode of operation:

ME EQUIPMENT type:

HAND-HELD and PORTABLE

## Electromagnetic Compatibility

IEC 60601-1-2: 2001

IEC 60601-1-2 Amendment 1: 2004

## Electromagnetic Emissions

This Model ZM-520PA/530PA is intended for use in the electromagnetic environment specified below. The customer or the user of the ZM-520PA/530PA should assure that it is used in such an environment.

<b>Emissions test</b>	<b>Compliance</b>	<b>Electromagnetic environment - guidance</b>
RF emissions CISPR 11	Group 1	The ZM-520PA/530PA uses RF energy only for its internal function. Therefore, its RF emissions are very low and are not likely to cause any interference in nearby electronic equipment.
RF emissions CISPR 11	Class B	The ZM-520PA/530PA is suitable for use in all establishments, including domestic establishments.
Harmonic emissions IEC 61000-3-2	Not applicable	
Voltage fluctuations/ flicker emissions IEC 61000-3-3	Not applicable	

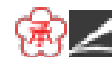

## Electromagnetic Immunity

This Model ZM-520PA/530PA is intended for use in the electromagnetic environment specified below. The customer or the user of the ZM-520PA/530PA should assure that it is used in such an environment.

Immunity test	IEC 60601 test level	Compliance level	Electromagnetic environment - guidance
Electrostatic discharge (ESD) IEC 61000-4-2	±6 kV contact ±8 kV air	±6 kV contact ±8 kV air	Floors should be wood, concrete or ceramic tile. If floors are covered with synthetic material, the relative humidity should be at least 30%.
Electrical fast transient/burst IEC 61000-4-4	±2 kV for power supply lines ±1 kV for input/output lines	Not applicable	—
Surge IEC 61000-4-5	±1 kV differential mode ±2 kV common mode	Not applicable	—
Voltage dips, short interruptions and voltage variations on power supply input lines IEC 61000-4-11	<5% $U_T$ (>95% dip in $U_T$ ) for 0.5 cycles  40% $U_T$ (60% dip in $U_T$ ) for 5 cycles  70% $U_T$ (30% dip in $U_T$ ) for 25 cycles  <5% $U_T$ (>95% dip in $U_T$ ) for 5 s	Not applicable	—
Power frequency (50/60 Hz) magnetic field IEC 61000-4-8	3 A/m	3 A/m	Power frequency magnetic fields should be at levels characteristic of a typical location in a typical commercial or hospital environment.

NOTE:  $U_T$  is the AC mains voltage prior to application of the test level.

### Avoiding Electromagnetic Interference (Impedance Respiration)

Impedance respiration measurement is very sensitive and affected by electromagnetic interference. Technological limitations do not allow immunity levels higher than 1 V/m for radiated RF electromagnetic fields. Electromagnetic fields with field strengths above 1 V/m may cause RF measurement error. Do not use electrically radiating equipment near the impedance respiration measurements.

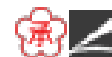

Immunity test	IEC 60601 test level	Compliance level	Electromagnetic environment - guidance
<p>Conducted RF IEC 61000-4-6</p> <p>Radiated RF IEC 61000-4-3</p>	<p>3 Vrms 150 kHz to 80 MHz</p> <p>3 V/m 80 MHz to 2.5 GHz</p>	<p>3 Vrms</p> <p>3 V/m 80 MHz to 2.5 GHz</p> <p>(1 V/m 80 MHz to 2.5 GHz for respiration)</p>	<p>Portable and mobile RF communications equipment should be used no closer to any part of the ZM-520PA/530PA, including cables, than the recommended separation distance calculated from the equation applicable to the frequency of the transmitter.</p> <p><b>Recommended separation distance</b></p> <p><math>d = 1.2\sqrt{P}</math></p> <p><math>d = 1.2\sqrt{P}</math> 80 MHz to 800 MHz  <math>d = 2.3\sqrt{P}</math> 800 MHz to 2.5 GHz</p> <p>(<math>d = 3.5\sqrt{P}</math> 80 MHz to 800 MHz for respiration  <math>d = 7.0\sqrt{P}</math> 800 MHz to 2.5 GHz for respiration)</p> <p>where P is the maximum output power rating of the transmitter in watts (W) according to the transmitter manufacturer and d is the recommended separation distance in meters (m).</p> <p>Field strengths from fixed RF transmitters, as determined by an electromagnetic site survey*<sup>1</sup>, should be less than the compliance level in each frequency range*<sup>2</sup>.</p> <p>Interference may occur in the vicinity of equipment marked with the following symbol:</p> 
NOTE 1: At 80 MHz and 800 MHz, the higher frequency range applies.			
NOTE 2: These guidelines may not apply in all situations. Electromagnetic propagation is affected by absorption and reflection from structures, objects and people.			
<p>*<sup>1</sup> Field strengths from fixed transmitters, such as base stations for radio (cellular/cordless) telephones and land mobile radios, amateur radio, AM and FM radio broadcast and TV broadcast cannot be predicted theoretically with accuracy. To assess the electromagnetic environment due to fixed RF transmitters, an electromagnetic site survey should be considered. If the measured field strength in the location in which the ZM-520PA/530PA is used exceeds the applicable RF compliance level above, the ZM-520PA/530PA should be observed to verify normal operation. If abnormal performance is observed, additional measures may be necessary, such as re-orienting or relocating the ZM-520PA/530PA.</p> <p>*<sup>2</sup> Over the frequency range 150 kHz to 80 MHz, field strengths should be less than 1 V/m for respiration and 3 V/m for all other functions.</p>			



## Recommended Separation Distances between Portable and Mobile RF Communications Equipment

The ZM-520PA/530PA is intended for use in an electromagnetic environment in which radiated RF disturbances are controlled. The customer or the user of the ZM-520PA/530PA can help prevent electromagnetic interference by maintaining a minimum distance between portable and mobile RF communications equipment (transmitters) and the ZM-520PA/530PA as recommended below, according to the maximum output power of the communications equipment.

Rated maximum output power of transmitter (W)	Separation distance according to frequency of transmitter (m)		
	150 kHz to 80 MHz $d = 1.2\sqrt{P}$	80 MHz to 800 MHz $d = 1.2\sqrt{P}$  (For respiration: $d = 3.5\sqrt{P}$ )	800 MHz to 2.5 GHz $d = 2.3\sqrt{P}$  (For respiration: $d = 7.0\sqrt{P}$ )
0.01	0.12	0.12 (0.35*)	0.23 (0.7*)
0.1	0.38	0.38 (1.1*)	0.73 (2.2*)
1	1.2	1.2 (3.5*)	2.3 (7.0*)
10	3.8	3.8 (11*)	7.3 (22*)
100	12	12 (35*)	23 (70*)

For transmitters rated at a maximum output power not listed above, the recommended separation distance  $d$  in meters (m) can be estimated using the equation applicable to the frequency of the transmitter, where  $P$  is the maximum output power rating of the transmitter in watts (W) according to the transmitter manufacturer.

(\* For respiration)

NOTE 1: At 80 MHz and 800 MHz, the separation distance for the higher frequency range applies.

NOTE 2: These guidelines may not apply in all situations. Electromagnetic propagation is affected by absorption and reflection from structures, objects and people.

## Recovery Time after Defibrillation

The transmitter returns to the normal operating mode within 10 seconds after defibrillation. The stored settings are not affected.

## System Composition for EMC Test

The ZM-520PA/530PA bedside monitor is tested to comply with IEC 60601-1-2: 2001 with the following composition.

Units	Cable Length
ZM-520PA/530PA transmitter	—
BR-906P ECG electrode lead	0.8 m
TL-201T finger probe	1.6 m





## ZM-521PA/531PA

### Measuring Parameters

Measuring waveforms:	ECG, respiration in impedance method, pulse
Measuring numeric data:	Heart rate, respiration rate, SpO <sub>2</sub> , pulse rate

### Transmitting Data

Waveform data:	ECG, respiration, pulse wave
Numeric data:	SpO <sub>2</sub> , pulse rate
Status information:	Battery replacement, battery level*, alarm suspended, pause monitoring*, patient confirmed*, ECG lead, pacing detection, electrode detachment, electrode impedance*, ECG off*, respiration method (impedance)*, SpO <sub>2</sub> status, respiration status*, channel ID, time constant (3.2 s), type of transmitter, transmitter code number*, transmitter serial number*

\* The items marked with \* are transmitted only when the protocol is "51".

### Display

Display size:	2.2 inch TFT color LCD
Viewing area:	44.16 (H) × 33.12 (V) mm
Resolution:	320 (H) × 240 (V) dots

### Displayed Data

Numeric and waveform screen:	ECG (one waveform from lead I, II, III, Va or Vb), heart rate, pulse rate, respiration rate, SpO <sub>2</sub> , message, battery level, QRS/pulse sync mark, pulse bar graph, ECG lead
Waveform review screen:	ECG or pulse wave of past 10 minutes
Numeric review screen:	Heart rate or pulse rate, respiration rate and SpO <sub>2</sub> at 1 minute interval for past 10 minutes
Check electrodes screen:	ECG for checking electrode attachment

### ECG

#### ECG measurement

Channels:	4
Input dynamic range:	±10 mV or more
Electrode offset potential tolerance:	±500 mV or more
Input impedance:	5 MΩ or more
Common mode rejection ratio:	95 dB or more
Pacing pulse detection:	IEC 60601-2-27: 2005 50.102.10 complied amplitude ±2 to 700 mV, duration 0.1 to 2 ms IEC 60601-2-27: 2005 complied Based upon pacemaker pulse rejection capability



Defibrillation-proof:	ECG input protected against 400 Ws/DC 5 kV IEC 60601-2-27 17.101 complied
ECG recovery time after defibrillation:	within 10 s
Electrode condition:	Displays CHECK ELECTRODES message
Tall T-wave rejection capability:	Complies with the heights of T-waves from 0 to 1.2 mV IEC 60601-2-27: 2005 50.102.17 complied
Heart rate averaging:	Calculated by using the most recent 8 beats.
Heart rate meter accuracy and response to irregular rhythm:	Ventricular bigeminy (Test waveform name: aami3a*): 80 bpm Slow alternating ventricular bigeminy (Test waveform name: aami3b*): 60 bpm Rapid alternating ventricular bigeminy (Test waveform name: aami3c*): 108 bpm Bidirectional systoles (Test waveform name: aami3d*): 88 bpm * The test waveforms can be download at <a href="http://www.physionet.org">http://www.physionet.org</a>
Response time of heart rate meter to change in heart rate:	HR change from 80 to 120 bpm: 4 to 8 seconds HR change from 80 to 40 bpm: 11 to 15 seconds
Pacemaker pulse rejection capability, without overshoot:	Complies with the amplitudes of pacemaker pulses $\pm 2$ to $\pm 700$ mV and widths 0.1 to 2 ms (specified in IEC 60601-2- 27: 2005 50.102.13)
Pacemaker pulse rejection capability, with overshoot:	Overshoot amplitudes and time constants of $\pm 0.12$ mV/100 ms to $\pm 2$ mV/4 ms (As defined by method B of IEC 60601- 2-27: 2005 50.102.13, this corresponds to the pacemaker pulses amplitudes and widths of $\pm 4$ mV/2 ms to amplitudes $\pm 80$ mV/0.1 ms.)
<b>ECG display and heart rate count</b>	
Frequency characteristic:	filter on: 1 to 18 Hz, filter off: 0.05 to 60 Hz
Heart rate detection method:	Average
QRS detection:	70 to 120 ms: amplitude $\geq 0.5$ mV, rate 30 to 200 beats/min 40 to 120 ms: amplitude $\geq 0.5$ mV, rate 30 to 250 beats/min
Heart rate counting range:	0, 15 to 300 beats/min
Heart rate counting accuracy*:	$\pm 2$ beats/min, (0, 15 to 300 beats/min)
* Essential performance of this transmitter	

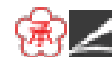

## Respiration Measurement

Measuring method:	Impedance method
Measuring lead:	Between R and F
Impedance range:	220 to 2000 $\Omega$
Excitor current:	54 to 93 $\mu$ Ap-p, 48 kHz
Respiration rate measuring accuracy*:	$\pm 2$ counts/min (at 0 to 150 counts/min)
Respiration rate counting range:	0 to 150 counts/min

\* Essential performance of this transmitter

## SpO<sub>2</sub> Measurement (ISO 9919: 2005 compliance)

Measuring range:	0 to 100%SpO <sub>2</sub>
Declared range:	70 to 100%SpO <sub>2</sub>
Minimum display range:	1%SpO <sub>2</sub>
Display update cycle:	Every 3 seconds
Measuring accuracy (rms)*:	Accuracy assurance temperature: 18 to 40°C
Total accuracy including probe:	80%SpO <sub>2</sub> $\leq$ %SpO <sub>2</sub> $\leq$ 100%SpO <sub>2</sub> : $\pm 2\%$ SpO <sub>2</sub> 70%SpO <sub>2</sub> $\leq$ %SpO <sub>2</sub> $<$ 80%SpO <sub>2</sub> : $\pm 3\%$ SpO <sub>2</sub> under 70%SpO <sub>2</sub> : not specified
Accuracy of the transmitter:	80%SpO <sub>2</sub> $\leq$ %SpO <sub>2</sub> $\leq$ 100%SpO <sub>2</sub> : $\pm 1\%$ SpO <sub>2</sub> 50%SpO <sub>2</sub> $\leq$ %SpO <sub>2</sub> $<$ 80%SpO <sub>2</sub> : $\pm 2\%$ SpO <sub>2</sub> under 50%SpO <sub>2</sub> : not specified
Pulse rate measuring range:	30 to 300 bpm
Pulse rate display range:	30 to 300 bpm
Pulse rate accuracy (rms)*:	$\pm 3\% \pm 1$ bpm

\* Essential performance of this transmitter

### NOTE

- The SpO<sub>2</sub> measuring accuracy was tested using the TL-201T, TL-260T, TL-271T and TL-631T SpO<sub>2</sub> probes. The testing was performed during induced hypoxia on healthy volunteers (Ethnicity: 10 Caucasians, 2 Africans, 1 Asian and 3 Indians), (Skin: 8 light, 4 medium, 4 dark), (Age: 21 to 34), (5 women and 11 men) under the condition of no motion. Arterial blood was sampled and measured by a CO-oximeter. The difference between SpO<sub>2</sub> measured by the SpO<sub>2</sub> probe and functional SaO<sub>2</sub> measured by a CO-oximeter was calculated using the root-mean-square (rms) method according to ISO 9919: 2005. This measurement accuracy figure represents 2/3 of all test measurements.
- A pulse oximeter tester that generates simulated signals can be used to check the difference from the design specification, but it cannot be used as a replacement for human signals for testing accuracy.



Response time:

Selectable from “Slow”, “Normal” and “Fast”.

The following graphs show the response time example when SpO<sub>2</sub> changes 0.6%/s.

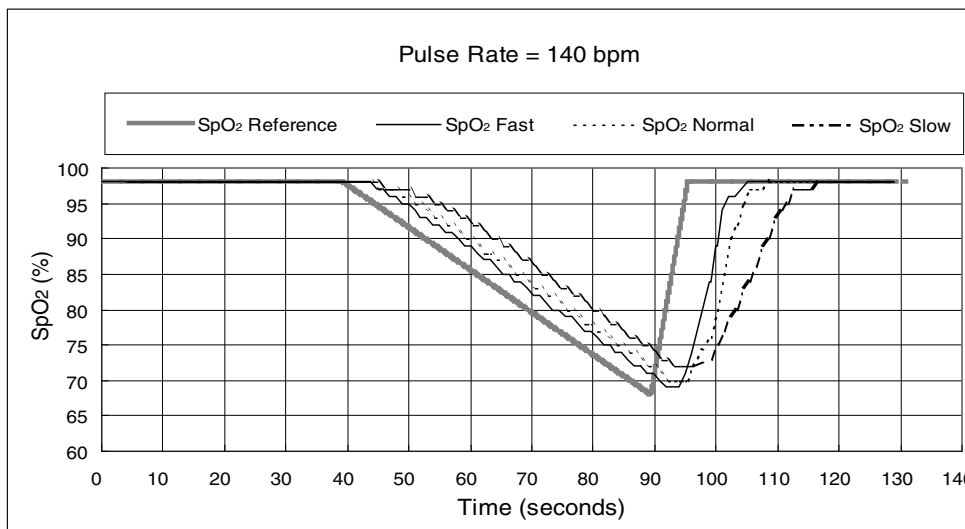
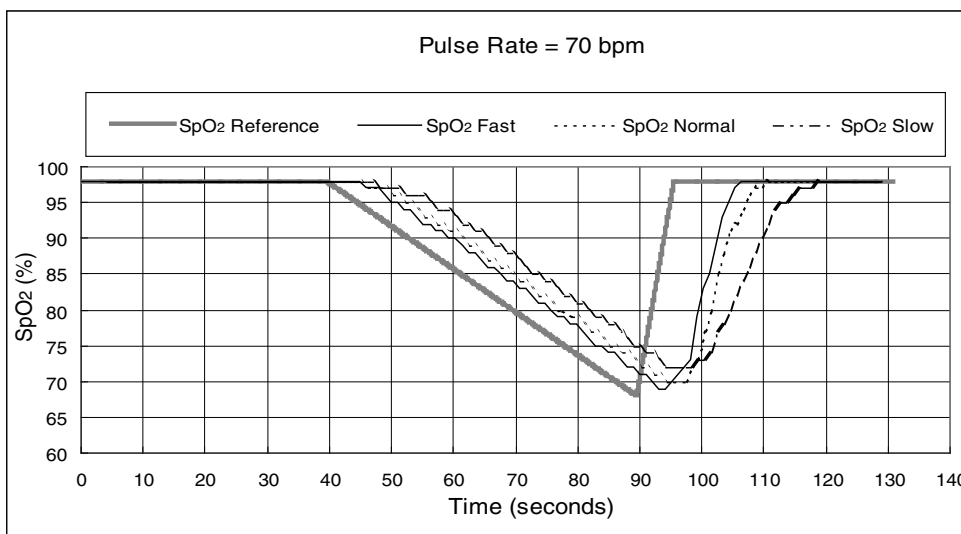

The following graph shows the response time example when pulse rate changes 10 bpm/s.

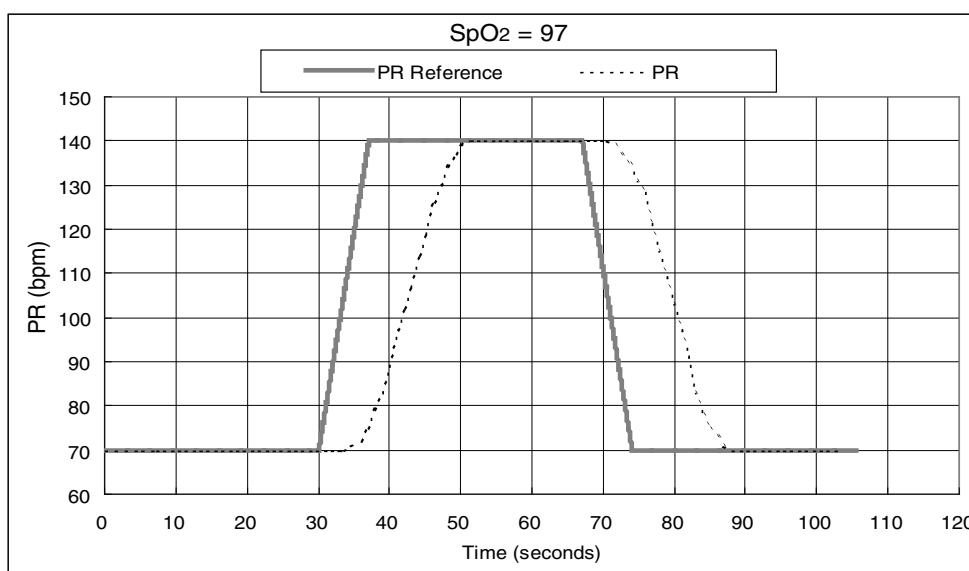

## Transmitter

FCC regulation:	FCC part 95 Subpart H Wireless Medical Telemetry Service (WMTS)
Field strength limits:	$\leq 740$ mV/m (at 3 m)
Undesired emissions:	$\leq 960$ MHz: $\leq 200$ $\mu$ V/m (at 3 m) $\geq 960$ MHz: $\leq 500$ $\mu$ V/m (at 3 m)
Antenna:	Internal
Transmission channel:	Indicated on the transmitter
Transmission frequency range:	1395.0250 to 1399.9750 MHz 1427.0250 to 1431.9750 MHz
Channel spacing:	50 kHz or 37.5 kHz (12.5 kHz when interleaved)
Modulation:	FSK (frequency shift keying)
Type of emission:	F1D
Occupied bandwidth:	12 to 18 kHz
Effective radiated power:	5.0 mW Can be changed to 1.0 mW if required

## Power Requirements

Rated voltage:	3.0 V
Shutdown voltage:	1.4 to 1.75 V
Operating voltage:	Shutdown voltage to 3.2 V
Battery type:	Two AA (LR6) type alkaline dry cell primary batteries
Battery lifetime (with alkaline batteries, at room temperature):	
ZM-521PA:	approximately 2.5 day
ZM-531PA:	approximately 2 day (measuring ECG, respiration and SpO <sub>2</sub> ) approximately 2.5 day (measuring ECG and respiration)



## Dimension and Weight

Dimension:	78 W × 137 H × 36 D (mm)
Weight:	about 230 g (excluding batteries and other accessories) about 280 g (including batteries, excluding other accessories)

## Environment

### Operating environment

Temperature:	5 to 40°C (41 to 104°F)
Humidity:	30 to 85% (noncondensing)
Atmospheric pressure:	700 to 1060 hPa

### Storage and transport environment

Temperature:	-20 to +65°C (-4 to +149°F)
Humidity:	10 to 95%
Atmospheric pressure:	700 to 1060 hPa

### Water resistance

Water does not get inside the transmitter when immersed in water up to 30 cm deep for 3 minutes.

## Safety Standards

Safety standard:	CAN/CSA-C22.2 No. 601-1 M90 CAN/CSA-C22.2 No. 601-1. 1S1-94 CAN/CSA-C22.2 No. 601-1. 1B-90 CAN/CSA-C22.2 No. 60601-2-49-04 CAN/CSA-C22.2 No. 60601-2-27-06 IEC 60601-1: 1988 IEC 60601-1 Amendment 1: 1991 IEC 60601-1 Amendment 2: 1995 IEC 60601-2-27: 2005 IEC 60601-2-49: 2001 ISO 9919: 2005 UL 60601-1: 2003
------------------	---

Type of protection against electrical shock:  
INTERNALLY POWERED EQUIPMENT

Degree of protection against electrical shock:  
ECG and impedance method respiration:  
DEFIBRILLATION-PROOF TYPE CF APPLIED PART  
SpO<sub>2</sub>:  
DEFIBRILLATION-PROOF TYPE BF APPLIED PART

Degree of protection against harmful ingress of water:  
IPX0 (non-protected)

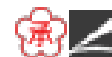

Degree of safety of application in the presence of a FLAMMABLE ANAESTHETIC MIXTURE WITH AIR, OR WITH OXYGEN OR NITROUS OXIDE:

Equipment not suitable for use in the presence of  
FLAMMABLE ANAESTHETIC MIXTURE WITH  
AIR, OR WITH OXYGEN OR NITROUS OXIDE  
CONTINUOUS OPERATION

Mode of operation:

ME EQUIPMENT type:

HAND-HELD and PORTABLE

## Electromagnetic Compatibility

IEC 60601-1-2: 2001

IEC 60601-1-2 Amendment 1: 2004

## Electromagnetic Emissions

This Model ZM-521PA/531PA is intended for use in the electromagnetic environment specified below. The customer or the user of the ZM-521PA/531PA should assure that it is used in such an environment.

<b>Emissions test</b>	<b>Compliance</b>	<b>Electromagnetic environment - guidance</b>
RF emissions CISPR 11	Group 1	The ZM-521PA/531PA uses RF energy only for its internal function. Therefore, its RF emissions are very low and are not likely to cause any interference in nearby electronic equipment.
RF emissions CISPR 11	Class B	The ZM-521PA/531PA is suitable for use in all establishments, including domestic establishments.
Harmonic emissions IEC 61000-3-2	Not applicable	
Voltage fluctuations/ flicker emissions IEC 61000-3-3	Not applicable	



## Electromagnetic Immunity

This Model ZM-521PA/531PA is intended for use in the electromagnetic environment specified below. The customer or the user of the ZM-521PA/531PA should assure that it is used in such an environment.

Immunity test	IEC 60601 test level	Compliance level	Electromagnetic environment - guidance
Electrostatic discharge (ESD) IEC 61000-4-2	±6 kV contact ±8 kV air	±6 kV contact ±8 kV air	Floors should be wood, concrete or ceramic tile. If floors are covered with synthetic material, the relative humidity should be at least 30%.
Electrical fast transient/burst IEC 61000-4-4	±2 kV for power supply lines ±1 kV for input/output lines	Not applicable	—
Surge IEC 61000-4-5	±1 kV differential mode ±2 kV common mode	Not applicable	—
Voltage dips, short interruptions and voltage variations on power supply input lines IEC 61000-4-11	<5% $U_T$ (>95% dip in $U_T$ ) for 0.5 cycles  40% $U_T$ (60% dip in $U_T$ ) for 5 cycles  70% $U_T$ (30% dip in $U_T$ ) for 25 cycles  <5% $U_T$ (>95% dip in $U_T$ ) for 5 s	Not applicable	—
Power frequency (50/60 Hz) magnetic field IEC 61000-4-8	3 A/m	3 A/m	Power frequency magnetic fields should be at levels characteristic of a typical location in a typical commercial or hospital environment.

NOTE:  $U_T$  is the AC mains voltage prior to application of the test level.

### Avoiding Electromagnetic Interference (Impedance Respiration)

Impedance respiration measurement is very sensitive and affected by electromagnetic interference. Technological limitations do not allow immunity levels higher than 1 V/m for radiated RF electromagnetic fields. Electromagnetic fields with field strengths above 1 V/m may cause RF measurement error. Do not use electrically radiating equipment near the impedance respiration measurements.





Immunity test	IEC 60601 test level	Compliance level	Electromagnetic environment - guidance
<p>Conducted RF IEC 61000-4-6</p> <p>Radiated RF IEC 61000-4-3</p>	<p>3 Vrms 150 kHz to 80 MHz</p> <p>3 V/m 80 MHz to 2.5 GHz</p>	<p>3 Vrms</p> <p>3 V/m 80 MHz to 2.5 GHz</p> <p>(1 V/m 80 MHz to 2.5 GHz for respiration)</p>	<p>Portable and mobile RF communications equipment should be used no closer to any part of the ZM-521PA/531PA, including cables, than the recommended separation distance calculated from the equation applicable to the frequency of the transmitter.</p> <p><b>Recommended separation distance</b></p> <p><math>d = 1.2\sqrt{P}</math></p> <p><math>d = 1.2\sqrt{P}</math> 80 MHz to 800 MHz  <math>d = 2.3\sqrt{P}</math> 800 MHz to 2.5 GHz</p> <p>(<math>d = 3.5\sqrt{P}</math> 80 MHz to 800 MHz for respiration  <math>d = 7.0\sqrt{P}</math> 800 MHz to 2.5 GHz for respiration)</p> <p>where P is the maximum output power rating of the transmitter in watts (W) according to the transmitter manufacturer and d is the recommended separation distance in meters (m).</p> <p>Field strengths from fixed RF transmitters, as determined by an electromagnetic site survey*<sup>1</sup>, should be less than the compliance level in each frequency range*<sup>2</sup>.</p> <p>Interference may occur in the vicinity of equipment marked with the following symbol: </p>
NOTE 1: At 80 MHz and 800 MHz, the higher frequency range applies.			
NOTE 2: These guidelines may not apply in all situations. Electromagnetic propagation is affected by absorption and reflection from structures, objects and people.			
<p>*<sup>1</sup> Field strengths from fixed transmitters, such as base stations for radio (cellular/cordless) telephones and land mobile radios, amateur radio, AM and FM radio broadcast and TV broadcast cannot be predicted theoretically with accuracy. To assess the electromagnetic environment due to fixed RF transmitters, an electromagnetic site survey should be considered. If the measured field strength in the location in which the ZM-521PA/531PA is used exceeds the applicable RF compliance level above, the ZM-521PA/531PA should be observed to verify normal operation. If abnormal performance is observed, additional measures may be necessary, such as re-orienting or relocating the ZM-521PA/531PA.</p> <p>*<sup>2</sup> Over the frequency range 150 kHz to 80 MHz, field strengths should be less than 1 V/m for respiration and 3 V/m for all other functions.</p>			



## Recommended Separation Distances between Portable and Mobile RF Communications Equipment

The ZM-521PA/531PA is intended for use in an electromagnetic environment in which radiated RF disturbances are controlled. The customer or the user of the ZM-521PA/531PA can help prevent electromagnetic interference by maintaining a minimum distance between portable and mobile RF communications equipment (transmitters) and the ZM-521PA/531PA as recommended below, according to the maximum output power of the communications equipment.

Rated maximum output power of transmitter (W)	Separation distance according to frequency of transmitter (m)		
	150 kHz to 80 MHz $d = 1.2\sqrt{P}$	80 MHz to 800 MHz $d = 1.2\sqrt{P}$  (For respiration: $d = 3.5\sqrt{P}$ )	800 MHz to 2.5 GHz $d = 2.3\sqrt{P}$  (For respiration: $d = 7.0\sqrt{P}$ )
0.01	0.12	0.12 (0.35*)	0.23 (0.7*)
0.1	0.38	0.38 (1.1*)	0.73 (2.2*)
1	1.2	1.2 (3.5*)	2.3 (7.0*)
10	3.8	3.8 (11*)	7.3 (22*)
100	12	12 (35*)	23 (70*)

For transmitters rated at a maximum output power not listed above, the recommended separation distance  $d$  in meters (m) can be estimated using the equation applicable to the frequency of the transmitter, where  $P$  is the maximum output power rating of the transmitter in watts (W) according to the transmitter manufacturer.

(\* For respiration)

NOTE 1: At 80 MHz and 800 MHz, the separation distance for the higher frequency range applies.

NOTE 2: These guidelines may not apply in all situations. Electromagnetic propagation is affected by absorption and reflection from structures, objects and people.

## Recovery Time after Defibrillation

The transmitter returns to the normal operating mode within 10 seconds after defibrillation. The stored settings are not affected.

## System Composition for EMC Test

The ZM-521PA/531PA bedside monitor is tested to comply with IEC 60601-1-2: 2001 with the following composition.

Units	Cable Length
ZM-521PA/531PA transmitter	—
BR-906P ECG electrode lead	0.8 m
TL-201T finger probe	1.6 m



## Standard Accessories



Name	Model	Q'ty	Supply Code No.
Strap	—	1	Y233



## Options

### CAUTION

Only use Nihon Kohden specified electrodes, electrode leads and SpO<sub>2</sub> probes.  
Otherwise, the maximum performance from the transmitter cannot be guaranteed.

### Transmitter

Channel writer, QI-901PK

### ECG/RESP

Name	Purpose		Length (m)	Code No.	Q'ty	Supply Code No.
Electrode lead	3 electrodes	AHA, clip type	0.8	BR-903PA	1	K911A
	6 electrodes			BR-906PA		K912A
Disposable electrodes, Vitrode	General		-	L-150	30 × 5	G203
				L-150X		G207
				F-150M	3 × 50	G210D
	General with DIN type lead		1.0	V-090M3	3 × 30	G272A
			1.5	V-09IO3		G278A
			1.0	V-040M4	4 × 10	G272B
			1.5	V-04IO4		G273A
			1.0	V-060M6	6 × 10	G272C
			1.5	V-06IO6		G274A
	For neonates and premature infants For NICU		-	F-150S	3 × 50	G210C
	For neonates and premature infants For NICU with DIN type lead		60 cm	V-120S3	3 × 40	G271A
N-03IS3				3 × 10	G300A	



## SpO<sub>2</sub>

Name	Cable Length	Model/ Code No.	Q'ty	Supply Code No.	
Finger probe (reusable)	0.6 m	TL-201T	1	P225H	
	1.6 m			P225F	
Multi-site probe (reusable)	1.6 m	TL-220T		P225G	
Finger probe (reusable)	0.6 m	TL-631T1		P311A	
	1.6 m	TL-631T3		P311C	
SpO <sub>2</sub> probe (for adult, disposable)	0.8 m	TL-271T		24	P203A
	1.6 m	TL-271T3	P203E		
SpO <sub>2</sub> probe (for child, disposable)	0.8 m	TL-272T	P203B		
	1.6 m	TL-272T3	P203F		
SpO <sub>2</sub> probe (for neonate/adult, disposable)	0.8 m	TL-273T	P203C		
	1.6 m	TL-273T3	P203G		
SpO <sub>2</sub> probe (for child/infant, disposable)	0.8 m	TL-274T	P203D		
	1.6 m	TL-274T3	P203H		
SpO <sub>2</sub> probe (for adult/neonate, disposable)	0.8 m	TL-051S	5		P228A
	1.6 m	TL-052S			P228B
SpO <sub>2</sub> probe (for child/infant, disposable)	0.8 m	TL-061S			P229A
	1.6 m	TL-062S			P229B
COTTONY tape		340703	20	P259	
Foam tape for TL-051S/052S/ 061S/062S			4 × 25 packages	P260	
Attachment tape for TL- 220T/631T	—	—	3 × 30 packages	P263	
Probe fastener		YS-093P2	30	P267	



## Transmission Frequencies

Channel: 9002 to 9478

Transmission Frequency (MHz)	Channel No.	Transmission Frequency (MHz)	Channel No.	Transmission Frequency (MHz)	Channel No.
608.0250	9002	608.4375	9035	608.8500	9068
608.0375	9003	608.4500	9036	608.8625	9069
608.0500	9004	608.4625	9037	608.8750	9070
608.0625	9005	608.4750	9038	608.8875	9071
608.0750	9006	608.4875	9039	608.9000	9072
608.0875	9007	608.5000	9040	608.9125	9073
608.1000	9008	608.5125	9041	608.9250	9074
608.1125	9009	608.5250	9042	608.9375	9075
608.1250	9010	608.5375	9043	608.9500	9076
608.1375	9011	608.5500	9044	608.9625	9077
608.1500	9012	608.5625	9045	608.9750	9078
608.1625	9013	608.5750	9046	608.9875	9079
608.1750	9014	608.5875	9047	609.0000	9080
608.1875	9015	608.6000	9048	609.0125	9081
608.2000	9016	608.6125	9049	609.0250	9082
608.2125	9017	608.6250	9050	609.0375	9083
608.2250	9018	608.6375	9051	609.0500	9084
608.2375	9019	608.6500	9052	609.0625	9085
608.2500	9020	608.6625	9053	609.0750	9086
608.2625	9021	608.6750	9054	609.0875	9087
608.2750	9022	608.6875	9055	609.1000	9088
608.2875	9023	608.7000	9056	609.1125	9089
608.3000	9024	608.7125	9057	609.1250	9090
608.3125	9025	608.7250	9058	609.1375	9091
608.3250	9026	608.7375	9059	609.1500	9092
608.3375	9027	608.7500	9060	609.1625	9093
608.3500	9028	608.7625	9061	609.1750	9094
608.3625	9029	608.7750	9062	609.1875	9095
608.3750	9030	608.7875	9063	609.2000	9096
608.3875	9031	608.8000	9064	609.2125	9097
608.4000	9032	608.8125	9065	609.2250	9098



Transmission Frequency (MHz)	Channel No.	Transmission Frequency (MHz)	Channel No.	Transmission Frequency (MHz)	Channel No.
608.4125	9033	608.8250	9066	609.2375	9099
608.4250	9034	608.8375	9067	609.2500	9100
609.2625	9101	609.7125	9137	610.1625	9173
609.2750	9102	609.7250	9138	610.1750	9174
609.2875	9103	609.7375	9139	610.1875	9175
609.3000	9104	609.7500	9140	610.2000	9176
609.3125	9105	609.7625	9141	610.2125	9177
609.3250	9106	609.7750	9142	610.2250	9178
609.3375	9107	609.7875	9143	610.2375	9179
609.3500	9108	609.8000	9144	610.2500	9180
609.3625	9109	609.8125	9145	610.2625	9181
609.3750	9110	609.8250	9146	610.2750	9182
609.3875	9111	609.8375	9147	610.2875	9183
609.4000	9112	609.8500	9148	610.3000	9184
609.4125	9113	609.8625	9149	610.3125	9185
609.4250	9114	609.8750	9150	610.3250	9186
609.4375	9115	609.8875	9151	610.3375	9187
609.4500	9116	609.9000	9152	610.3500	9188
609.4625	9117	609.9125	9153	610.3625	9189
609.4750	9118	609.9250	9154	610.3750	9190
609.4875	9119	609.9375	9155	610.3875	9191
609.5000	9120	609.9500	9156	610.4000	9192
609.5125	9121	609.9625	9157	610.4125	9193
609.5250	9122	609.9750	9158	610.4250	9194
609.5375	9123	609.9875	9159	610.4375	9195
609.5500	9124	610.0000	9160	610.4500	9196
609.5625	9125	610.0125	9161	610.4625	9197
609.5750	9126	610.0250	9162	610.4750	9198
609.5875	9127	610.0375	9163	610.4875	9199
609.6000	9128	610.0500	9164	610.5000	9200
609.6125	9129	610.0625	9165	610.5125	9201
609.6250	9130	610.0750	9166	610.5250	9202
609.6375	9131	610.0875	9167	610.5375	9203
609.6500	9132	610.1000	9168	610.5500	9204
609.6625	9133	610.1125	9169	610.5625	9205

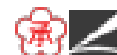

Transmission Frequency (MHz)	Channel No.	Transmission Frequency (MHz)	Channel No.	Transmission Frequency (MHz)	Channel No.
609.6750	9134	610.1250	9170	610.5750	9206
609.6875	9135	610.1375	9171	610.5875	9207
609.7000	9136	610.1500	9172	610.6000	9208
610.6125	9209	611.0625	9245	611.5125	9281
610.6250	9210	611.0750	9246	611.5250	9282
610.6375	9211	611.0875	9247	611.5375	9283
610.6500	9212	611.1000	9248	611.5500	9284
610.6625	9213	611.1125	9249	611.5625	9285
610.6750	9214	611.1250	9250	611.5750	9286
610.6875	9215	611.1375	9251	611.5875	9287
610.7000	9216	611.1500	9252	611.6000	9288
610.7125	9217	611.1625	9253	611.6125	9289
610.7250	9218	611.1750	9254	611.6250	9290
610.7375	9219	611.1875	9255	611.6375	9291
610.7500	9220	611.2000	9256	611.6500	9292
610.7625	9221	611.2125	9257	611.6625	9293
610.7750	9222	611.2250	9258	611.6750	9294
610.7875	9223	611.2375	9259	611.6875	9295
610.8000	9224	611.2500	9260	611.7000	9296
610.8125	9225	611.2625	9261	611.7125	9297
610.8250	9226	611.2750	9262	611.7250	9298
610.8375	9227	611.2875	9263	611.7375	9299
610.8500	9228	611.3000	9264	611.7500	9300
610.8625	9229	611.3125	9265	611.7625	9301
610.8750	9230	611.3250	9266	611.7750	9302
610.8875	9231	611.3375	9267	611.7875	9303
610.9000	9232	611.3500	9268	611.8000	9304
610.9125	9233	611.3625	9269	611.8125	9305
610.9250	9234	611.3750	9270	611.8250	9306
610.9375	9235	611.3875	9271	611.8375	9307
610.9500	9236	611.4000	9272	611.8500	9308
610.9625	9237	611.4125	9273	611.8625	9309
610.9750	9238	611.4250	9274	611.8750	9310
610.9875	9239	611.4375	9275	611.8875	9311
611.0000	9240	611.4500	9276	611.9000	9312





Transmission Frequency (MHz)	Channel No.	Transmission Frequency (MHz)	Channel No.	Transmission Frequency (MHz)	Channel No.
611.0125	9241	611.4625	9277	611.9125	9313
611.0250	9242	611.4750	9278	611.9250	9314
611.0375	9243	611.4875	9279	611.9375	9315
611.0500	9244	611.5000	9280	611.9500	9316
611.9625	9317	612.4125	9353	612.8625	9389
611.9750	9318	612.4250	9354	612.8750	9390
611.9875	9319	612.4375	9355	612.8875	9391
612.0000	9320	612.4500	9356	612.9000	9392
612.0125	9321	612.4625	9357	612.9125	9393
612.0250	9322	612.4750	9358	612.9250	9394
612.0375	9323	612.4875	9359	612.9375	9395
612.0500	9324	612.5000	9360	612.9500	9396
612.0625	9325	612.5125	9361	612.9625	9397
612.0750	9326	612.5250	9362	612.9750	9398
612.0875	9327	612.5375	9363	612.9875	9399
612.1000	9328	612.5500	9364	613.0000	9400
612.1125	9329	612.5625	9365	613.0125	9401
612.1250	9330	612.5750	9366	613.0250	9402
612.1375	9331	612.5875	9367	613.0375	9403
612.1500	9332	612.6000	9368	613.0500	9404
612.1625	9333	612.6125	9369	613.0625	9405
612.1750	9334	612.6250	9370	613.0750	9406
612.1875	9335	612.6375	9371	613.0875	9407
612.2000	9336	612.6500	9372	613.1000	9408
612.2125	9337	612.6625	9373	613.1125	9409
612.2250	9338	612.6750	9374	613.1250	9410
612.2375	9339	612.6875	9375	613.1375	9411
612.2500	9340	612.7000	9376	613.1500	9412
612.2625	9341	612.7125	9377	613.1625	9413
612.2750	9342	612.7250	9378	613.1750	9414
612.2875	9343	612.7375	9379	613.1875	9415
612.3000	9344	612.7500	9380	613.2000	9416
612.3125	9345	612.7625	9381	613.2125	9417
612.3250	9346	612.7750	9382	613.2250	9418
612.3375	9347	612.7875	9383	613.2375	9419
612.3500	9348	612.8000	9384	613.2500	9420



Transmission Frequency (MHz)	Channel No.	Transmission Frequency (MHz)	Channel No.	Transmission Frequency (MHz)	Channel No.
612.3625	9349	612.8125	9385	613.2625	9421
612.3750	9350	612.8250	9386	613.2750	9422
612.3875	9351	612.8375	9387	613.2875	9423
612.4000	9352	612.8500	9388	613.3000	9424
613.3125	9425	613.5375	9443	613.7625	9461
613.3250	9426	613.5500	9444	613.7750	9462
613.3375	9427	613.5625	9445	613.7875	9463
613.3500	9428	613.5750	9446	613.8000	9464
613.3625	9429	613.5875	9447	613.8125	9465
613.3750	9430	613.6000	9448	613.8250	9466
613.3875	9431	613.6125	9449	613.8375	9467
613.4000	9432	613.6250	9450	613.8500	9468
613.4125	9433	613.6375	9451	613.8625	9469
613.4250	9434	613.6500	9452	613.8750	9470
613.4375	9435	613.6625	9453	613.8875	9471
613.4500	9436	613.6750	9454	613.9000	9472
613.4625	9437	613.6875	9455	613.9125	9473
613.4750	9438	613.7000	9456	613.9250	9474
613.4875	9439	613.7125	9457	613.9375	9475
613.5000	9440	613.7250	9458	613.9500	9476
613.5125	9441	613.7375	9459	613.9625	9477
613.5250	9442	613.7500	9460	613.9750	9478

Channel: E002 to E398

Transmission Frequency (MHz)	Channel No.	Transmission Frequency (MHz)	Channel No.	Transmission Frequency (MHz)	Channel No.
1395.0250	E002	1395.4625	E037	1395.9000	E072
1395.0375	E003	1395.4750	E038	1395.9125	E073
1395.0500	E004	1395.4875	E039	1395.9250	E074
1395.0625	E005	1395.5000	E040	1395.9375	E075
1395.0750	E006	1395.5125	E041	1395.9500	E076
1395.0875	E007	1395.5250	E042	1395.9625	E077
1395.1000	E008	1395.5375	E043	1395.9750	E078



Transmission Frequency (MHz)	Channel No.	Transmission Frequency (MHz)	Channel No.	Transmission Frequency (MHz)	Channel No.
1395.1125	E009	1395.5500	E044	1395.9875	E079
1395.1250	E010	1395.5625	E045	1396.0000	E080
1395.1375	E011	1395.5750	E046	1396.0125	E081
1395.1500	E012	1395.5875	E047	1396.0250	E082
1395.1625	E013	1395.6000	E048	1396.0375	E083
1395.1750	E014	1395.6125	E049	1396.0500	E084
1395.1875	E015	1395.6250	E050	1396.0625	E085
1395.2000	E016	1395.6375	E051	1396.0750	E086
1395.2125	E017	1395.6500	E052	1396.0875	E087
1395.2250	E018	1395.6625	E053	1396.1000	E088
1395.2375	E019	1395.6750	E054	1396.1125	E089
1395.2500	E020	1395.6875	E055	1396.1250	E090
1395.2625	E021	1395.7000	E056	1396.1375	E091
1395.2750	E022	1395.7125	E057	1396.1500	E092
1395.2875	E023	1395.7250	E058	1396.1625	E093
1395.3000	E024	1395.7375	E059	1396.1750	E094
1395.3125	E025	1395.7500	E060	1396.1875	E095
1395.3250	E026	1395.7625	E061	1396.2000	E096
1395.3375	E027	1395.7750	E062	1396.2125	E097
1395.3500	E028	1395.7875	E063	1396.2250	E098
1395.3625	E029	1395.8000	E064	1396.2375	E099
1395.3750	E030	1395.8125	E065	1396.2500	E100
1395.3875	E031	1395.8250	E066	1396.2625	E101
1395.4000	E032	1395.8375	E067	1396.2750	E102
1395.4125	E033	1395.8500	E068	1396.2875	E103
1395.4250	E034	1395.8625	E069	1396.3000	E104
1395.4375	E035	1395.8750	E070	1396.3125	E105
1395.4500	E036	1395.8875	E071	1396.3250	E106
1396.3375	E107	1396.7875	E143	1397.2375	E179
1396.3500	E108	1396.8000	E144	1397.2500	E180
1396.3625	E109	1396.8125	E145	1397.2625	E181
1396.3750	E110	1396.8250	E146	1397.2750	E182
1396.3875	E111	1396.8375	E147	1397.2875	E183
1396.4000	E112	1396.8500	E148	1397.3000	E184
1396.4125	E113	1396.8625	E149	1397.3125	E185



Transmission Frequency (MHz)	Channel No.	Transmission Frequency (MHz)	Channel No.	Transmission Frequency (MHz)	Channel No.
1396.4250	E114	1396.8750	E150	1397.3250	E186
1396.4375	E115	1396.8875	E151	1397.3375	E187
1396.4500	E116	1396.9000	E152	1397.3500	E188
1396.4625	E117	1396.9125	E153	1397.3625	E189
1396.4750	E118	1396.9250	E154	1397.3750	E190
1396.4875	E119	1396.9375	E155	1397.3875	E191
1396.5000	E120	1396.9500	E156	1397.4000	E192
1396.5125	E121	1396.9625	E157	1397.4125	E193
1396.5250	E122	1396.9750	E158	1397.4250	E194
1396.5375	E123	1396.9875	E159	1397.4375	E195
1396.5500	E124	1397.0000	E160	1397.4500	E196
1396.5625	E125	1397.0125	E161	1397.4625	E197
1396.5750	E126	1397.0250	E162	1397.4750	E198
1396.5875	E127	1397.0375	E163	1397.4875	E199
1396.6000	E128	1397.0500	E164	1397.5000	E200
1396.6125	E129	1397.0625	E165	1397.5125	E201
1396.6250	E130	1397.0750	E166	1397.5250	E202
1396.6375	E131	1397.0875	E167	1397.5375	E203
1396.6500	E132	1397.1000	E168	1397.5500	E204
1396.6625	E133	1397.1125	E169	1397.5625	E205
1396.6750	E134	1397.1250	E170	1397.5750	E206
1396.6875	E135	1397.1375	E171	1397.5875	E207
1396.7000	E136	1397.1500	E172	1397.6000	E208
1396.7125	E137	1397.1625	E173	1397.6125	E209
1396.7250	E138	1397.1750	E174	1397.6250	E210
1396.7375	E139	1397.1875	E175	1397.6375	E211
1396.7500	E140	1397.2000	E176	1397.6500	E212
1396.7625	E141	1397.2125	E177	1397.6625	E213
1396.7750	E142	1397.2250	E178	1397.6750	E214
1397.6875	E215	1398.1375	E251	1398.5875	E287
1397.7000	E216	1398.1500	E252	1398.6000	E288
1397.7125	E217	1398.1625	E253	1398.6125	E289
1397.7250	E218	1398.1750	E254	1398.6250	E290
1397.7375	E219	1398.1875	E255	1398.6375	E291
1397.7500	E220	1398.2000	E256	1398.6500	E292

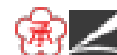

Transmission Frequency (MHz)	Channel No.	Transmission Frequency (MHz)	Channel No.	Transmission Frequency (MHz)	Channel No.
1397.7625	E221	1398.2125	E257	1398.6625	E293
1397.7750	E222	1398.2250	E258	1398.6750	E294
1397.7875	E223	1398.2375	E259	1398.6875	E295
1397.8000	E224	1398.2500	E260	1398.7000	E296
1397.8125	E225	1398.2625	E261	1398.7125	E297
1397.8250	E226	1398.2750	E262	1398.7250	E298
1397.8375	E227	1398.2875	E263	1398.7375	E299
1397.8500	E228	1398.3000	E264	1398.7500	E300
1397.8625	E229	1398.3125	E265	1398.7625	E301
1397.8750	E230	1398.3250	E266	1398.7750	E302
1397.8875	E231	1398.3375	E267	1398.7875	E303
1397.9000	E232	1398.3500	E268	1398.8000	E304
1397.9125	E233	1398.3625	E269	1398.8125	E305
1397.9250	E234	1398.3750	E270	1398.8250	E306
1397.9375	E235	1398.3875	E271	1398.8375	E307
1397.9500	E236	1398.4000	E272	1398.8500	E308
1397.9625	E237	1398.4125	E273	1398.8625	E309
1397.9750	E238	1398.4250	E274	1398.8750	E310
1397.9875	E239	1398.4375	E275	1398.8875	E311
1398.0000	E240	1398.4500	E276	1398.9000	E312
1398.0125	E241	1398.4625	E277	1398.9125	E313
1398.0250	E242	1398.4750	E278	1398.9250	E314
1398.0375	E243	1398.4875	E279	1398.9375	E315
1398.0500	E244	1398.5000	E280	1398.9500	E316
1398.0625	E245	1398.5125	E281	1398.9625	E317
1398.0750	E246	1398.5250	E282	1398.9750	E318
1398.0875	E247	1398.5375	E283	1398.9875	E319
1398.1000	E248	1398.5500	E284	1399.0000	E320
1398.1125	E249	1398.5625	E285	1399.0125	E321
1398.1250	E250	1398.5750	E286	1399.0250	E322
1399.0375	E323	1399.4625	E357	1399.8875	E391
1399.0500	E324	1399.4750	E358	1399.9000	E392
1399.0625	E325	1399.4875	E359	1399.9125	E393
1399.0750	E326	1399.5000	E360	1399.9250	E394
1399.0875	E327	1399.5125	E361	1399.9375	E395



Transmission Frequency (MHz)	Channel No.	Transmission Frequency (MHz)	Channel No.	Transmission Frequency (MHz)	Channel No.
1399.1000	E328	1399.5250	E362	1399.9500	E396
1399.1125	E329	1399.5375	E363	1399.9625	E397
1399.1250	E330	1399.5500	E364	1399.9750	E398
1399.1375	E331	1399.5625	E365		
1399.1500	E332	1399.5750	E366		
1399.1625	E333	1399.5875	E367		
1399.1750	E334	1399.6000	E368		
1399.1875	E335	1399.6125	E369		
1399.2000	E336	1399.6250	E370		
1399.2125	E337	1399.6375	E371		
1399.2250	E338	1399.6500	E372		
1399.2375	E339	1399.6625	E373		
1399.2500	E340	1399.6750	E374		
1399.2625	E341	1399.6875	E375		
1399.2750	E342	1399.7000	E376		
1399.2875	E343	1399.7125	E377		
1399.3000	E344	1399.7250	E378		
1399.3125	E345	1399.7375	E379		
1399.3250	E346	1399.7500	E380		
1399.3375	E347	1399.7625	E381		
1399.3500	E348	1399.7750	E382		
1399.3625	E349	1399.7875	E383		
1399.3750	E350	1399.8000	E384		
1399.3875	E351	1399.8125	E385		
1399.4000	E352	1399.8250	E386		
1399.4125	E353	1399.8375	E387		
1399.4250	E354	1399.8500	E388		
1399.4375	E355	1399.8625	E389		
1399.4500	E356	1399.8750	E390		

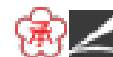

Channel: E502 to E898

Transmission Frequency (MHz)	Channel No.	Transmission Frequency (MHz)	Channel No.	Transmission Frequency (MHz)	Channel No.
1427.0250	E502	1427.4500	E536	1427.8750	E570
1427.0375	E503	1427.4625	E537	1427.8875	E571
1427.0500	E504	1427.4750	E538	1427.9000	E572
1427.0625	E505	1427.4875	E539	1427.9125	E573
1427.0750	E506	1427.5000	E540	1427.9250	E574
1427.0875	E507	1427.5125	E541	1427.9375	E575
1427.1000	E508	1427.5250	E542	1427.9500	E576
1427.1125	E509	1427.5375	E543	1427.9625	E577
1427.1250	E510	1427.5500	E544	1427.9750	E578
1427.1375	E511	1427.5625	E545	1427.9875	E579
1427.1500	E512	1427.5750	E546	1428.0000	E580
1427.1625	E513	1427.5875	E547	1428.0125	E581
1427.1750	E514	1427.6000	E548	1428.0250	E582
1427.1875	E515	1427.6125	E549	1428.0375	E583
1427.2000	E516	1427.6250	E550	1428.0500	E584
1427.2125	E517	1427.6375	E551	1428.0625	E585
1427.2250	E518	1427.6500	E552	1428.0750	E586
1427.2375	E519	1427.6625	E553	1428.0875	E587
1427.2500	E520	1427.6750	E554	1428.1000	E588
1427.2625	E521	1427.6875	E555	1428.1125	E589
1427.2750	E522	1427.7000	E556	1428.1250	E590
1427.2875	E523	1427.7125	E557	1428.1375	E591
1427.3000	E524	1427.7250	E558	1428.1500	E592
1427.3125	E525	1427.7375	E559	1428.1625	E593
1427.3250	E526	1427.7500	E560	1428.1750	E594
1427.3375	E527	1427.7625	E561	1428.1875	E595
1427.3500	E528	1427.7750	E562	1428.2000	E596
1427.3625	E529	1427.7875	E563	1428.2125	E597
1427.3750	E530	1427.8000	E564	1428.2250	E598
1427.3875	E531	1427.8125	E565	1428.2375	E599
1427.4000	E532	1427.8250	E566	1428.2500	E600
1427.4125	E533	1427.8375	E567	1428.2625	E601
1427.4250	E534	1427.8500	E568	1428.2750	E602





Transmission Frequency (MHz)	Channel No.	Transmission Frequency (MHz)	Channel No.	Transmission Frequency (MHz)	Channel No.
1427.4375	E535	1427.8625	E569	1428.2875	E603
1428.3000	E604	1428.7500	E640	1429.2000	E676
1428.3125	E605	1428.7625	E641	1429.2125	E677
1428.3250	E606	1428.7750	E642	1429.2250	E678
1428.3375	E607	1428.7875	E643	1429.2375	E679
1428.3500	E608	1428.8000	E644	1429.2500	E680
1428.3625	E609	1428.8125	E645	1429.2625	E681
1428.3750	E610	1428.8250	E646	1429.2750	E682
1428.3875	E611	1428.8375	E647	1429.2875	E683
1428.4000	E612	1428.8500	E648	1429.3000	E684
1428.4125	E613	1428.8625	E649	1429.3125	E685
1428.4250	E614	1428.8750	E650	1429.3250	E686
1428.4375	E615	1428.8875	E651	1429.3375	E687
1428.4500	E616	1428.9000	E652	1429.3500	E688
1428.4625	E617	1428.9125	E653	1429.3625	E689
1428.4750	E618	1428.9250	E654	1429.3750	E690
1428.4875	E619	1428.9375	E655	1429.3875	E691
1428.5000	E620	1428.9500	E656	1429.4000	E692
1428.5125	E621	1428.9625	E657	1429.4125	E693
1428.5250	E622	1428.9750	E658	1429.4250	E694
1428.5375	E623	1428.9875	E659	1429.4375	E695
1428.5500	E624	1429.0000	E660	1429.4500	E696
1428.5625	E625	1429.0125	E661	1429.4625	E697
1428.5750	E626	1429.0250	E662	1429.4750	E698
1428.5875	E627	1429.0375	E663	1429.4875	E699
1428.6000	E628	1429.0500	E664	1429.5000	E700
1428.6125	E629	1429.0625	E665	1429.5125	E701
1428.6250	E630	1429.0750	E666	1429.5250	E702
1428.6375	E631	1429.0875	E667	1429.5375	E703
1428.6500	E632	1429.1000	E668	1429.5500	E704
1428.6625	E633	1429.1125	E669	1429.5625	E705
1428.6750	E634	1429.1250	E670	1429.5750	E706
1428.6875	E635	1429.1375	E671	1429.5875	E707
1428.7000	E636	1429.1500	E672	1429.6000	E708
1428.7125	E637	1429.1625	E673	1429.6125	E709





Transmission Frequency (MHz)	Channel No.	Transmission Frequency (MHz)	Channel No.	Transmission Frequency (MHz)	Channel No.
1428.7250	E638	1429.1750	E674	1429.6250	E710
1428.7375	E639	1429.1875	E675	1429.6375	E711
1429.6500	E712	1430.1000	E748	1430.5500	E784
1429.6625	E713	1430.1125	E749	1430.5625	E785
1429.6750	E714	1430.1250	E750	1430.5750	E786
1429.6875	E715	1430.1375	E751	1430.5875	E787
1429.7000	E716	1430.1500	E752	1430.6000	E788
1429.7125	E717	1430.1625	E753	1430.6125	E789
1429.7250	E718	1430.1750	E754	1430.6250	E790
1429.7375	E719	1430.1875	E755	1430.6375	E791
1429.7500	E720	1430.2000	E756	1430.6500	E792
1429.7625	E721	1430.2125	E757	1430.6625	E793
1429.7750	E722	1430.2250	E758	1430.6750	E794
1429.7875	E723	1430.2375	E759	1430.6875	E795
1429.8000	E724	1430.2500	E760	1430.7000	E796
1429.8125	E725	1430.2625	E761	1430.7125	E797
1429.8250	E726	1430.2750	E762	1430.7250	E798
1429.8375	E727	1430.2875	E763	1430.7375	E799
1429.8500	E728	1430.3000	E764	1430.7500	E800
1429.8625	E729	1430.3125	E765	1430.7625	E801
1429.8750	E730	1430.3250	E766	1430.7750	E802
1429.8875	E731	1430.3375	E767	1430.7875	E803
1429.9000	E732	1430.3500	E768	1430.8000	E804
1429.9125	E733	1430.3625	E769	1430.8125	E805
1429.9250	E734	1430.3750	E770	1430.8250	E806
1429.9375	E735	1430.3875	E771	1430.8375	E807
1429.9500	E736	1430.4000	E772	1430.8500	E808
1429.9625	E737	1430.4125	E773	1430.8625	E809
1429.9750	E738	1430.4250	E774	1430.8750	E810
1429.9875	E739	1430.4375	E775	1430.8875	E811
1430.0000	E740	1430.4500	E776	1430.9000	E812
1430.0125	E741	1430.4625	E777	1430.9125	E813
1430.0250	E742	1430.4750	E778	1430.9250	E814
1430.0375	E743	1430.4875	E779	1430.9375	E815
1430.0500	E744	1430.5000	E780	1430.9500	E816

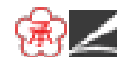

Transmission Frequency (MHz)	Channel No.	Transmission Frequency (MHz)	Channel No.	Transmission Frequency (MHz)	Channel No.
1430.0625	E745	1430.5125	E781	1430.9625	E817
1430.0750	E746	1430.5250	E782	1430.9750	E818
1430.0875	E747	1430.5375	E783	1430.9875	E819
1431.0000	E820	1431.4375	E855	1431.8750	E890
1431.0125	E821	1431.4500	E856	1431.8875	E891
1431.0250	E822	1431.4625	E857	1431.9000	E892
1431.0375	E823	1431.4750	E858	1431.9125	E893
1431.0500	E824	1431.4875	E859	1431.9250	E894
1431.0625	E825	1431.5000	E860	1431.9375	E895
1431.0750	E826	1431.5125	E861	1431.9500	E896
1431.0875	E827	1431.5250	E862	1431.9625	E897
1431.1000	E828	1431.5375	E863	1431.9750	E898
1431.1125	E829	1431.5500	E864		
1431.1250	E830	1431.5625	E865		
1431.1375	E831	1431.5750	E866		
1431.1500	E832	1431.5875	E867		
1431.1625	E833	1431.6000	E868		
1431.1750	E834	1431.6125	E869		
1431.1875	E835	1431.6250	E870		
1431.2000	E836	1431.6375	E871		
1431.2125	E837	1431.6500	E872		
1431.2250	E838	1431.6625	E873		
1431.2375	E839	1431.6750	E874		
1431.2500	E840	1431.6875	E875		
1431.2625	E841	1431.7000	E876		
1431.2750	E842	1431.7125	E877		
1431.2875	E843	1431.7250	E878		
1431.3000	E844	1431.7375	E879		
1431.3125	E845	1431.7500	E880		
1431.3250	E846	1431.7625	E881		
1431.3375	E847	1431.7750	E882		
1431.3500	E848	1431.7875	E883		
1431.3625	E849	1431.8000	E884		
1431.3750	E850	1431.8125	E885		
1431.3875	E851	1431.8250	E886		



Transmission Frequency (MHz)	Channel No.	Transmission Frequency (MHz)	Channel No.	Transmission Frequency (MHz)	Channel No.
1431.4000	E852	1431.8375	E887		
1431.4125	E853	1431.8500	E888		
1431.4250	E854	1431.8625	E889		