

MEMO

THE FCC WANTS YOU KNOW

This device complies with part 15 of the FCC Rules. Operation is subject to the following two conditions:

- (1) This device may not cause harmful interference.
- (2) This device must accept any interference received, including interference that may cause undesired operation.

Your R/C car might cause TV or radio interference even when it is operating properly.

To determine whether your R/C car is causing the interference, turn off your R/C car.

If the interference goes away, your R/C car is causing the interference.

Try to eliminate the interference by:

- Moving your R/C car away from the receiver.
- Contacting your local store for help.

If you cannot eliminate the interference, the FCC requires that you stop using your R/C car.

IT IS VIOLATION OF THE FCC REGULATIONS TO REMODEL OR ALTER THIS DEVICE IN ANYWAY WITHOUT PERMISSION. ANYONE WHO VIOLATES THE REGULATIONS WILL LOSE THE RIGHT TO OPERATE THE DEVICE.

Scale 1:14

Owner's Manual

HYPER JUMP ACTION RAZER

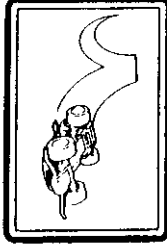

PRINTED IN MALAYSIA

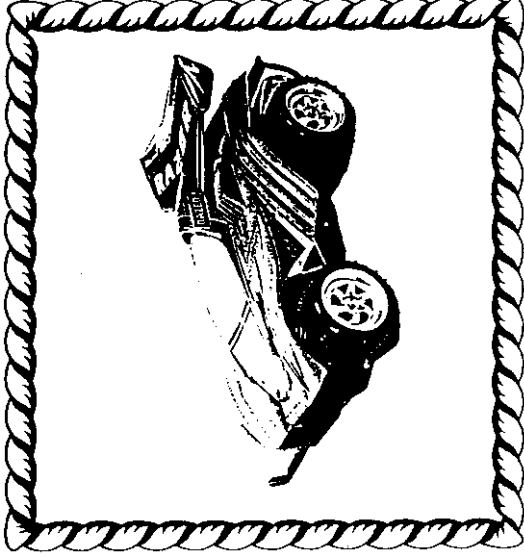

- Please read carefully before starting to operate.

FEATURES

- 3-channel full function + turbo running + jumping action
- Front & suspension
- Rear-wheel drive
- Equipped with jumping action system
- Detachable rear wing with fans
- 2-motor system (one for driving and one for jumping)

Battery requirements:

Vehicle: 1 x 9.6 V Ni-Cd battery pack

Transmitter: 1 x 9V(006P/6F22)

BEFORE YOU START

HOW TO INSTALL ANTENNA-TUBE

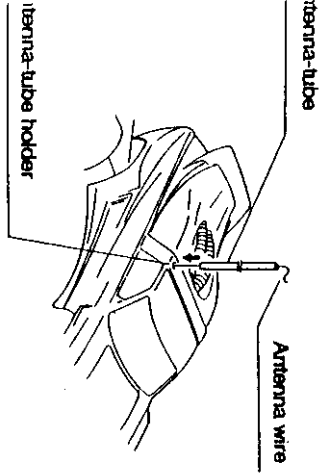

If the antenna tube cannot be successfully inserted into the antenna tube holder, hold the root of the antenna wire with fingers of one hand and extend the wire with fingers of the other hand.

* Note: Do not pull the antenna wire too hard.

● Pass antenna wire through antenna tube and insert the antenna tube into the antenna-tube holder.

HOW TO INSTALL TRANSMITTER ANTENNA

Place the transmitter antenna into the antenna holder to screw it in clockwise.

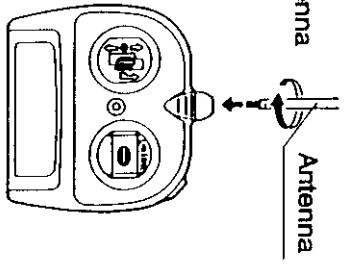

■ Do not install the antenna extended.

■ If the antenna is not screwed in securely, the vehicle may move erratically. Screw the antenna securely.

HOW TO INSTALL THE BATTERIES

Leaving batteries in the vehicle or the transmitter for a long period of time may cause battery leakage or other damage. Remove all the batteries both from the vehicle and the transmitter after use.

Transmitter

To remove the battery lid, press the point marked "OPEN" and pull the lid downward.

- Install battery making sure that + and - poles of the battery are positioned properly.

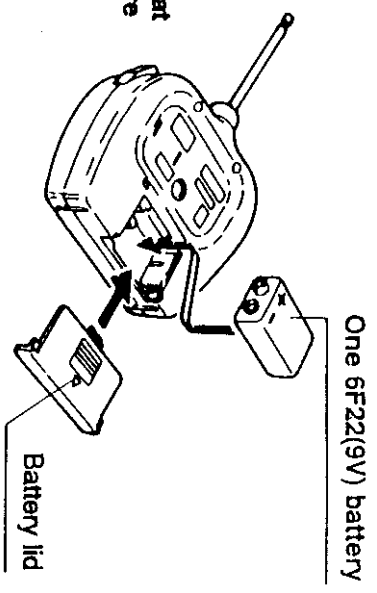

TO ADJUST STEERING ALIGNMENT

Adjust the steering alignment lever on the underside of the vehicle when the vehicle does not run straight.

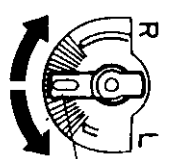

CLEANING

Wipe clean with something like a towel after playing.

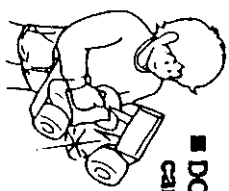

■ DO NOT use chemicals as they can deform or damage the body.

Caution: Never use chemicals including benzene, alcohol, or thinner.

TO RECHARGE 9.6 V NI-Cd BATTERY PACK

You have to remove 9.6 V NI-Cd battery pack from the vehicle to recharge.

- New NI-Cd battery packs are not charged. Charge before use.
1. Remove the battery pack from vehicle.
 2. Plug charger into ordinary household outlet.
 3. Join the connectors of the battery pack and charger.

CHARGER

- Plug directly into any household. Recharge NI-Cd battery pack hundreds of times.
- Read instruction of the pack and charger thoroughly before recharge the 9.6 V NI-Cd battery pack.

NOTE:

- Charger light should glow red during the charging.
- Average recharging time is approximately 4 to 5 hours.
- Additional charging will not increase the loading.
- Excessive recharging is dangerous and can possibly damage the batteries or battery pack.

WARNING:

Charge NI-Cd battery pack only. Do not charge flashlight, heavy duty, alkaline, transistor, mercury or other primary cell batteries as these can cause leakage, fire or explosion.

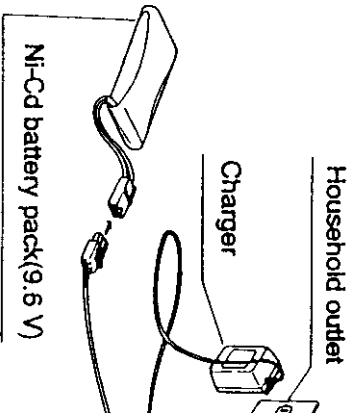

"Warning! use under the direct supervision of an adult."

When you connect the connectors, make certain the vehicle switch is in the "OFF" position.

1. Place the battery lid stopper to the vehicle in the "ON" position.

2. Open the battery lid. (Coin or similar thin object)

3. Insert the connector of the vehicle and the connector of the Ni-Cd battery pack, making sure that they are joined in the right direction.

4. Fit the Ni-Cd battery pack into the vehicle.

5. Close the battery lid and turn the battery lid stopper.

1 x Ni-Cd rechargeable battery pack (9.6 V, 600 mAh)

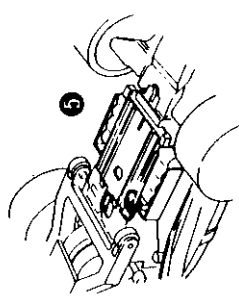
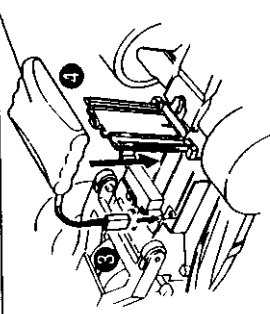
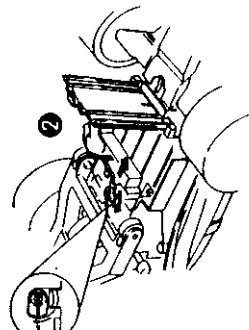

- When the connector cords are joined, tuck them away as shown.
- When you disconnect the connectors, don't pull by the cords.
- Avoid short circuit. It is very dangerous.
- Do not take the Ni-Cd battery pack apart or try to remodel it.

- When you connect the connectors, make certain the vehicle switch is in the "OFF" position.
- Set connectors properly. (The connectors are designed to be connected in only one way so that the positive (+) and the negative (-) terminals are connected accurately.)
- Disconnect the connectors immediately after a run.
- When you disconnect the connectors, don't pull by the cords.
- Avoid short circuits because it is very dangerous.
- Remove all the batteries both from the vehicle and the transmitter after a run.

HOW TO OPERATE THE VEHICLE (normal driving)

☆ The following instructions will show you how to make the car run.

1. Extend transmitter antenna to its full length. You can control the vehicle at a longer distance by holding the transmitter higher with the antenna straight up.



2. Turn ON the transmitter by operating the transmitter. (LED comes ON)

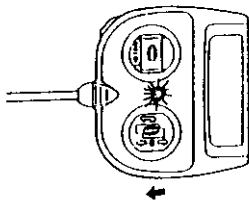

3. Turn the power switch of the vehicle ON.

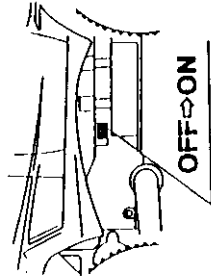

4. Start operating the vehicle.

FORWARD RUNNING

You can enjoy the excitement of 2 stages of speed from Normal(Low) Speed Forward Running to High Speed Forward Running by operating the Speed Control Stick. (Low Speed) (TURBO High Speed)

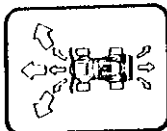
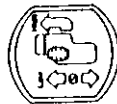

5. Turn the vehicle power switch OFF before removing the battery.

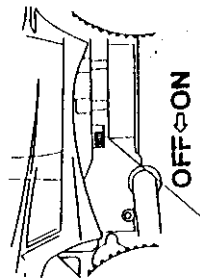

TURBO HIGH SPEED

LOW SPEED
NEUTRAL
BACKWARD

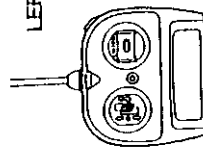

LEFT/STRAIGHT/RIGHT

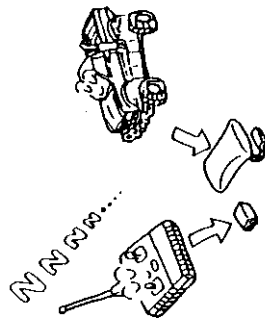

6. Remove all batteries from vehicle and transmitter.

OPERATING SAFETY RULES

select a **SAFE** place to operate your vehicle. Do not drive in the street. Avoid driving on **SAND** or through puddles of **WATER**. These hazards can impair performance. Check the surface ahead of you and watch for obstacles. Do not use the radio receiver in your vehicle and transmitter are sensitive instruments. Do not use the vehicle or Transmitter near sources of **HEAT** or under **DIRECT SUNLIGHT** for long periods of time.

Avoid leaving Vehicle or Transmitter **OUTSIDE OVERNIGHT**. **EXCESSIVE LIGHT DAMPNESS IS HARMFUL TO INTERIOR MECHANISM.**

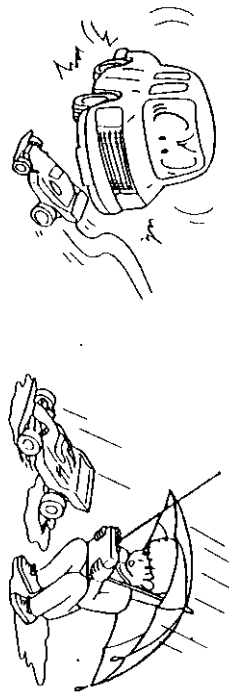

RADIO INTERFERENCE: Sometimes erratic behaviour or loss of control of vehicle is the result of interference caused by high tension wires, high voltage transformers certain types of building, concrete walls or narrow places where **RADIO SIGNALS** sent from your transmitter **MAY BE SCATTERED** thus making it **DIFFICULT** for your vehicle to receive a **GOOD RADIO SIGNAL**. If you encounter this type of behaviour or loss of control, **CHANGE TO A DIFFERENT LOCATION**.

You will encounter **INTERFERENCE** if **ANOTHER** radio controlled vehicle or **CB** radio is operating in the vicinity on your **SAME FREQUENCY**.

Cleaning and maintenance:
This toy vehicle needs periodic maintenance and cleaning.

Warning to the parents
The charger for the Ni-Cd battery pack needs periodic inspection to see that the lead wires, plugs, outer case, and other parts are not damaged in any way. If any of the parts are damaged, do not use the charger until it is completely repaired.

Caution
Keep out of reach of small children under 36 months old as there is danger of getting hurt.

NAMES OF PARTS

