

1/25 scale radio control yacht

# Mariner

RDC-19040BC

**Owner's Manual**

© NIKKO

PRINTED IN MALAYSIA.

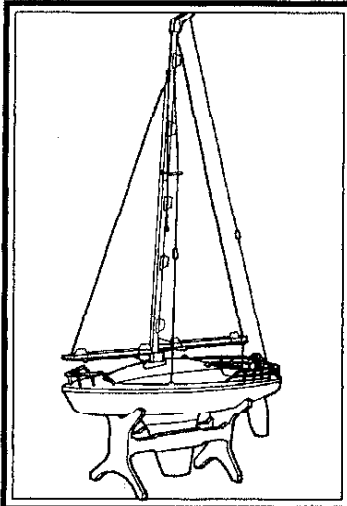

- Please read carefully before starting to operate.
- Video tape included  
(Make sure to watch the video before your start sailing the yacht.)
- **WARNING**  
Adult's supervision is requested for children.
- Keep the operation manual and display box for future reference.

IT IS A VIOLATION OF THE FCC REGULATIONS TO REMODEL OR ALTER THIS DEVICE IN ANY WAY WITHOUT PERMISSION, ANYONE WHO VIOLATES THE REGULATIONS WILL LOSE THE RIGHT TO OPERATE THE DEVICE.

#### CAUTION: ELECTRIC TOY

Not recommended for children under 8 years of age. As with all electric products, precautions should be observed during handling and use to prevent electric shock.

Input: 120 vac, 60 HZ 12W only.  
Output: 12 VDC, 3.6W

**NIKKO**  
AMERICA, INC

#### ATTENTION PARENTS

It is recommended that this toy and all accessories be periodically examined for potential hazards and that any potentially hazardous parts be repaired or replaced.

#### Repair and Parts Department

Monday to Friday 8:30AM-5:30PM Central Time

Repair:(800)736-4556

Parts:(800)776-4556

Fax:(972)578-7059

e-mail:nikkocs@airmail.net

#### FEATURES

- 1-channel functional rudder control system enables right and left turns. The rudder control system allows any form of yachting.
- Can be displayed on the display stand  
(Abundant accessories to present so high a sense of reality that the model can be a beautiful room decoration.)
- With an operation manual on a video tape: "How to Operate the Yacht"
- Ready-made and easy to operate

#### BATTERY REQUIREMENTS:

Transmitter: 1 x 006P (9V) battery

Yacht: 1 x Ni-Cd rechargeable battery pack (4.8V)

## TO RECHARGE 4.8 V NI-CD BATTERY PACK

You have to remove 4.8 V Ni-Cd battery pack from the vehicle to recharge.  
New Ni-Cd battery packs are not charged. Charge before use.

### HOW TO RECHARGE:

1. Join connectors of the Ni-Cd pack with the charger making sure that they are positioned properly.
2. Plug charger into ordinary household outlet.
3. Charge for approx. 4 – 5 hours.
4. Unplug the charger from the electrical outlet.
5. Unplug the battery pack connector from the charger.

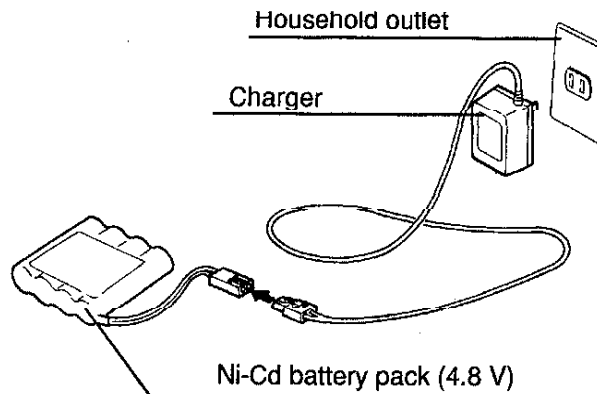

### To detach the connector

Press the stopper of the charger connector and pull out the connector.

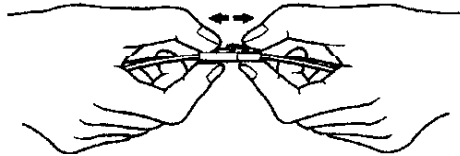

### Note:

- \* Keep the indicated charging time.
- \* Average charging time is approx. 4 to 5 hours.
- \* Additional charging will not improve the output of the battery pack.
- \* Excessive charging can possibly damage the charger or the battery pack and may be dangerous.

### Warning:

Charge Ni-Cd battery pack only.

Do not charge flashlight, heavy duty, alkaline, transistor, mercury or other primary cell batteries as this can cause leakage, fire or explosion.

## CAUTION WHEN CHARGING NI-CD BATTERY PACK

Be sure to read.

### Note:

The Ni Cd battery pack may get pretty heated while being charged. Place the battery pack on the nonflammable thing.

- Don't charge dry cell batteries. Don't disassemble, heat, or throw the batteries into fire.
- Excessive charging may not only shorten the battery pack life but also cause an unexpected accident.
- Insert the battery pack making sure that the + and - poles are positioned properly.
- Leaving batteries in the yacht or the transmitter for a long period of time may cause battery leakage or other damage. Remove all the batteries both from the vehicle and the transmitter after use.
- If the direction of the battery pack is wrong, you cannot insert it into the charger.
- Don't charge the heated battery pack immediately after use. Wait until it is cooled off.
- Keep the indicated charging time.
- Don't try to disassemble or remodel the charger or Ni-Cd battery pack.
- Don't charge when there is an infant around.
- Stop playing when the connector cords are severed. It's very dangerous.
- Don't charge where the temperature is extremely high, or low, or where it is wet or damp.
- When you disconnect the connectors, don't pull the cords as they can be severed.
- Charge at well-ventilated place.
- Don't let the charger and the Ni-Cd battery pack get wet.
- Don't charge the battery pack inside the R/C yacht.
- When charging, remain near the charger to observe the temperature of the charger and the Ni-Cd battery pack to prepare for an unexpected trouble.
- Charge fully discharged Ni-Cd battery pack only. (When the rudder become unmovable, the pack is discharged.)

## How to install the mast and sails

First, take out the mast and sails to install.

### 1. Mount the mast on the deck

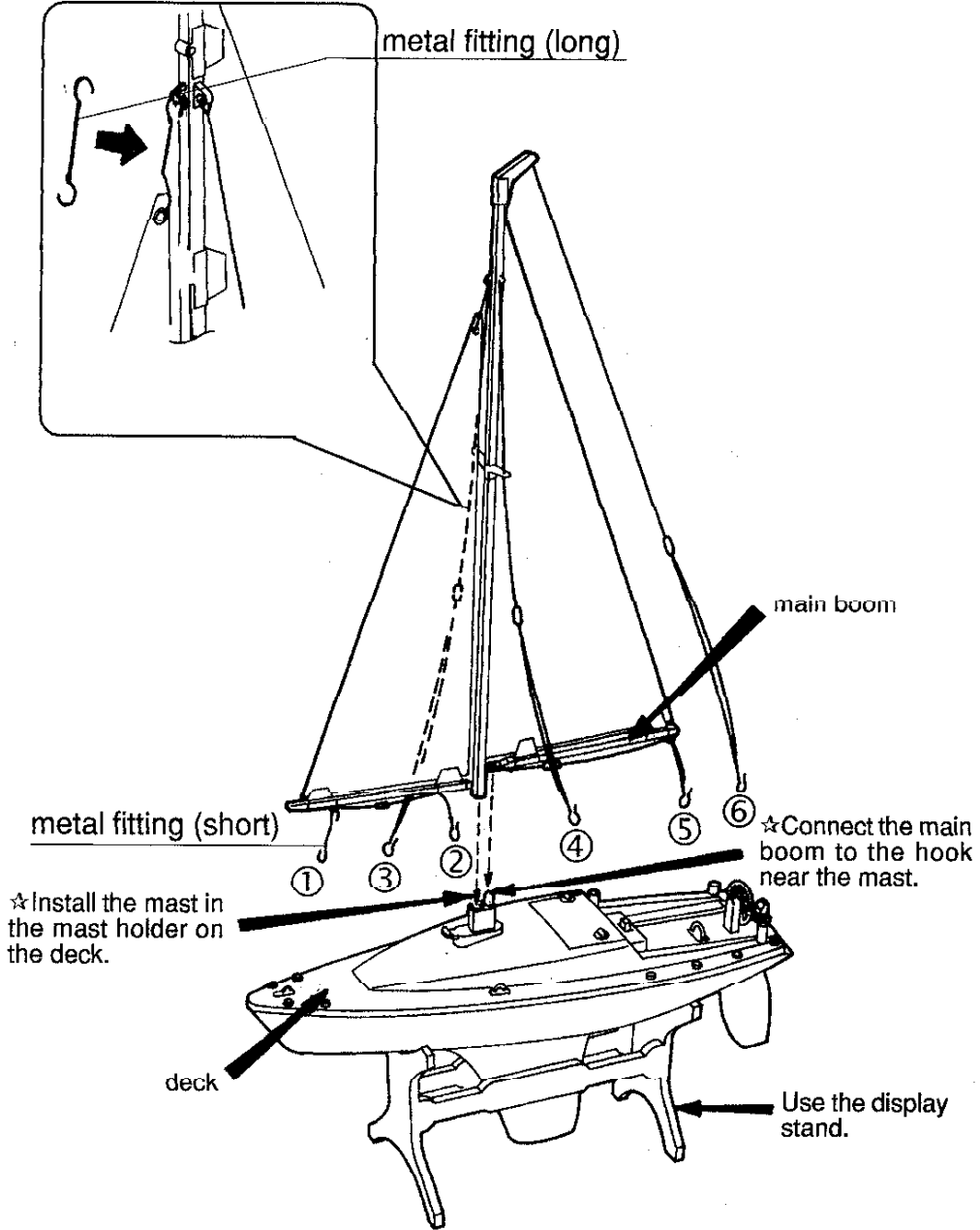

## 2. Hook the snaps

- Hook each snap as illustrated.

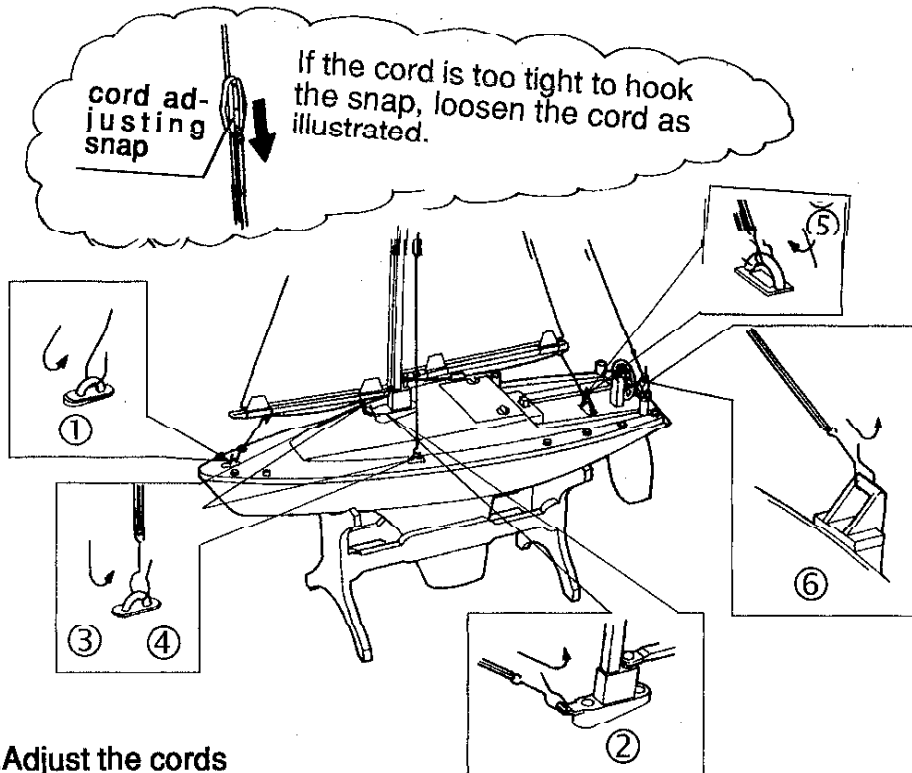

## 3. Adjust the cords

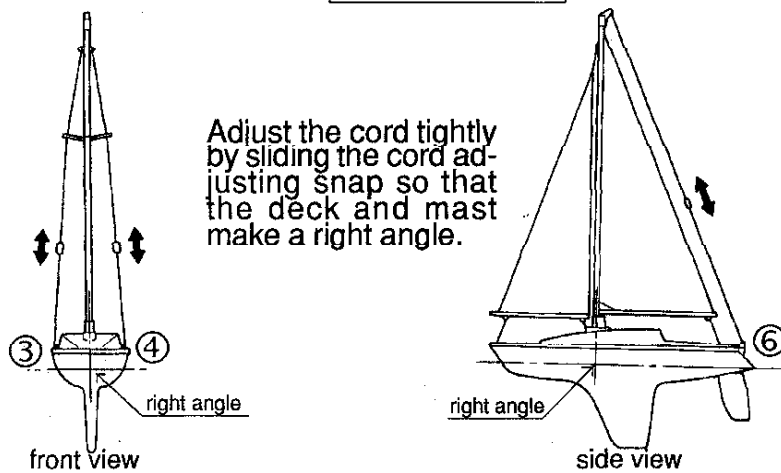

**Adjust ② and ③ by referring to "Adjusting Sail Tack".**

5

## BEFORE YOU START OPERATION

### ● How to install antenna tube.

Pass the antenna wire through the antenna-tube and insert the tube into the antenna-tube holder.

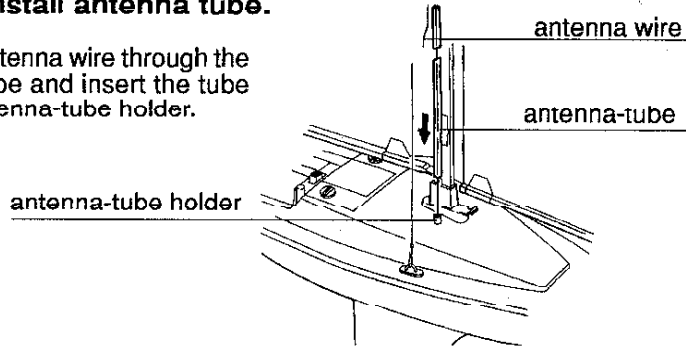

If the antenna tube cannot be successfully inserted into the antenna-tube holder, hold the root of the antenna wire with fingers of one hand and extend the wire with fingers of the other hand.

### ● How to install transmitter antenna

Place the transmitter antenna into the antenna holder and screw it in clockwise.

\* Do not install the antenna extended.

\* If the antenna is not screwed in securely, the yacht may move erratically. Screw the antenna securely.

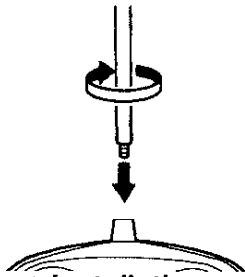

### ● Battery installation

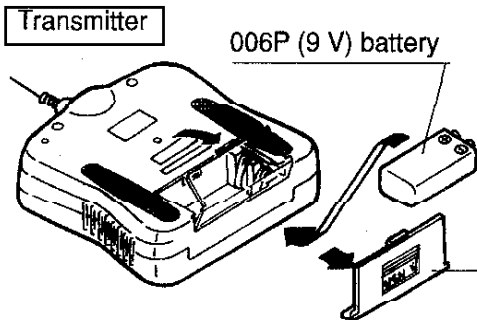

Remove the battery compartment lid. To remove the lid, pull the lid downward pressing the mark OPEN.

**Caution:**  
Install battery making sure that the + and - poles are positioned properly.

### ● HOW TO ATTACH A RIBBON

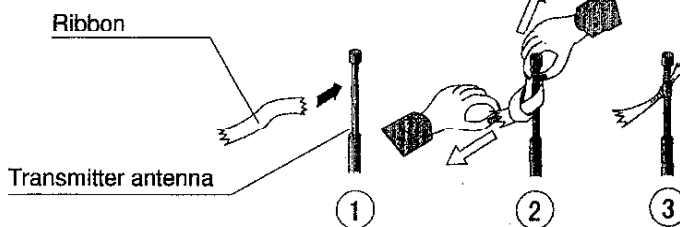

Tie a ribbon to transmitter antenna as shown.

You can check the direction and the velocity of the wind by using the ribbon.

**Main body**

Recharge the 4.8V battery after carefully reading the directions for the batteries and re-charger.

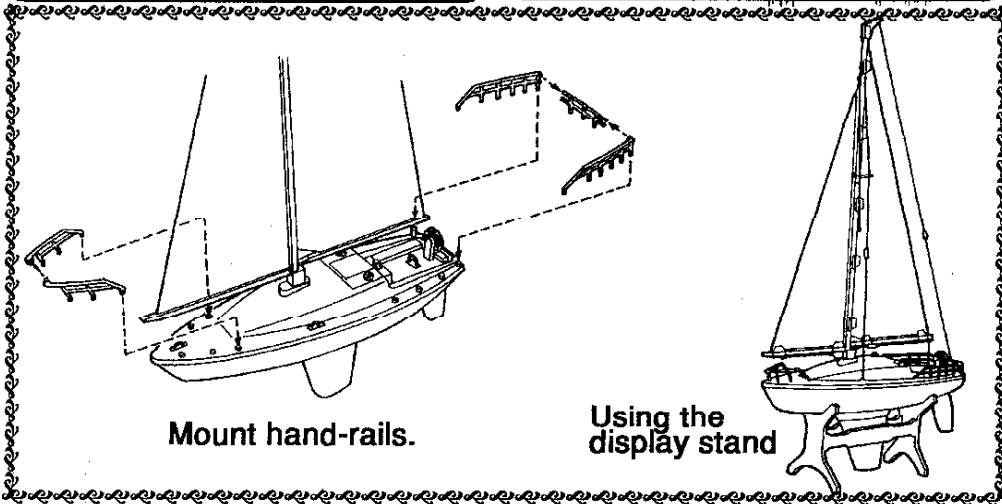
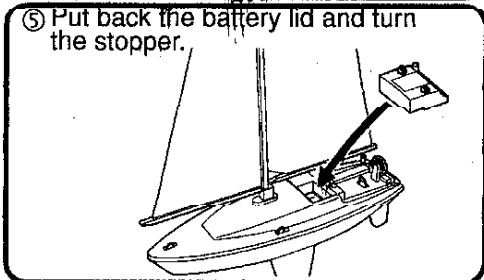
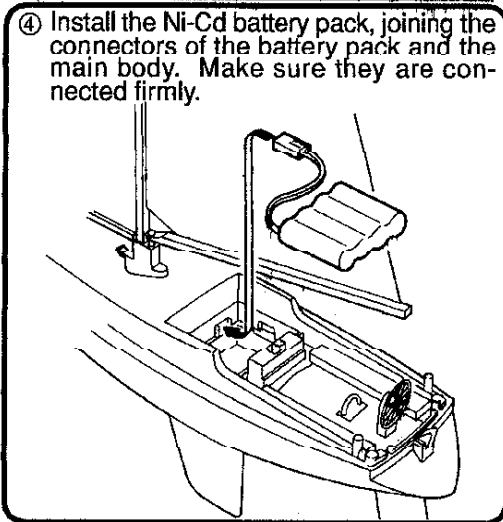
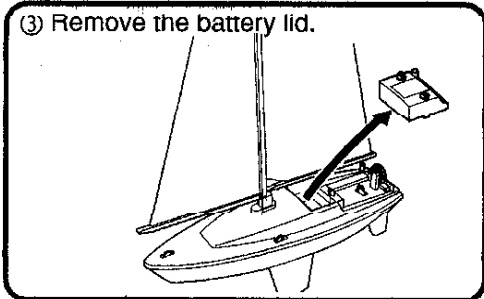
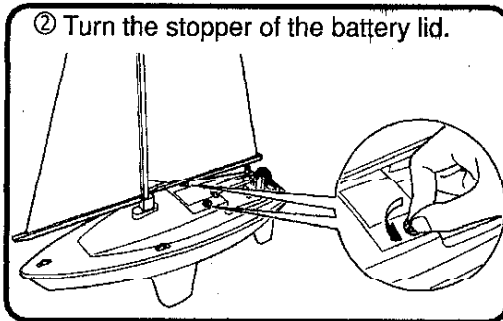
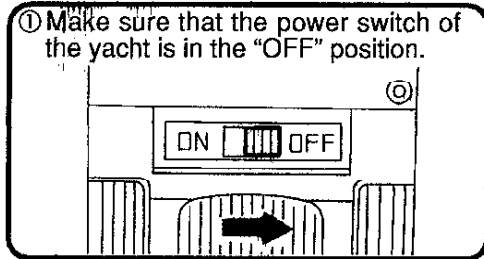

## Technical terms and the principle of sailing

### Shiver

When a yacht faces the wind, the sails shiver in the wind and do not function. In this case, the yacht halts.



### Sailing forms

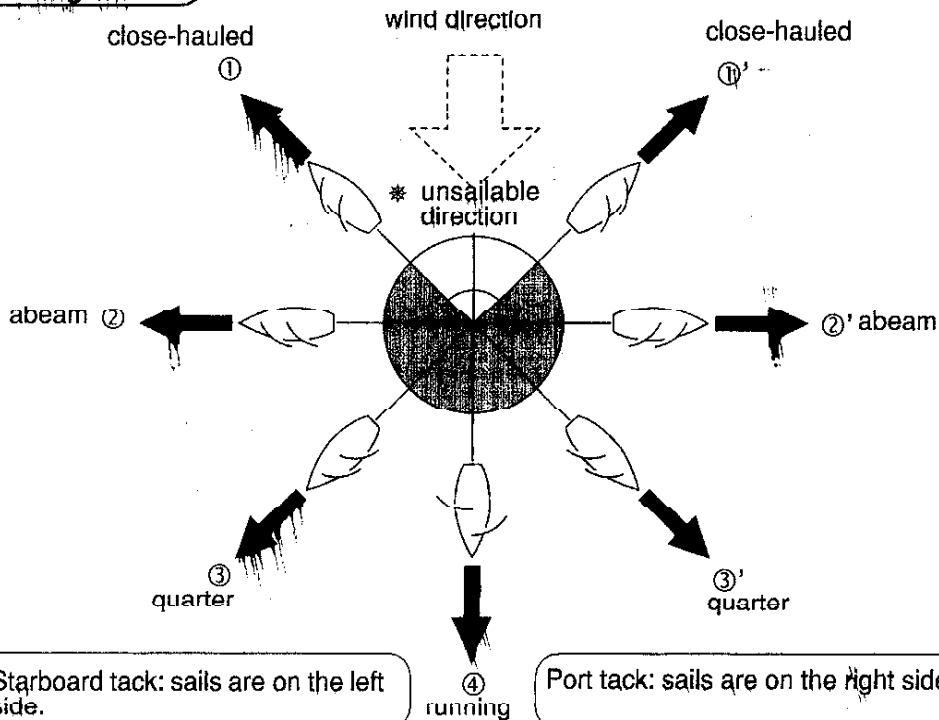

①①' The yacht is sailing toward the wind, hauling as close on the wind as possible but not so close as to shiver. Once this technique has been mastered, you can sail the yacht to reach the destination by zigzagging even if you cannot sail straight into the wind.

②②' The yacht is sailing with the wind coming abeam. The yacht can sail at its highest speed in this position. This is one of easy techniques for beginners.

③③' The yacht is sailing with the quartering wind and can sail as fast as in the ②②' case. However, if the wind is too strong, the rudder may become uncontrollable for you to collect the yacht. Do not sail when it is windy.

④ The yacht runs with the wind coming right behind (without depending on the Bernoulli's theorem). The point is to extend the sails across the sides to get as much wind as possible.

\* The area between 45° to the right and left facing the wind is where the yacht can not sail because of shivering of the sails.



## Bernoulli's theorem makes a yacht sail

The theorem that RC yachts sail forward is similar to the theorem that airplanes fly. It is because the cross sections of the wings and sails are similar and propulsive force of both airplanes and yachts is obtained from the effect of wind. When a wind blows, the speed of the wind on the surface of the front side and reverse side of the sail varies, thereby generating running lift "Z". Running lift "Z" has force "Y" which pushes the RC yacht sideways. To resist this force "Y", the keel is useful. Running lift "Z" transferred through the keel becomes resistance "Y" which negates the opposite force "Y". Then the remaining force "X" moves the RC yacht forward. (The above theory is called Bernoulli's theorem that explains how planes fly and how yachts move forward.)

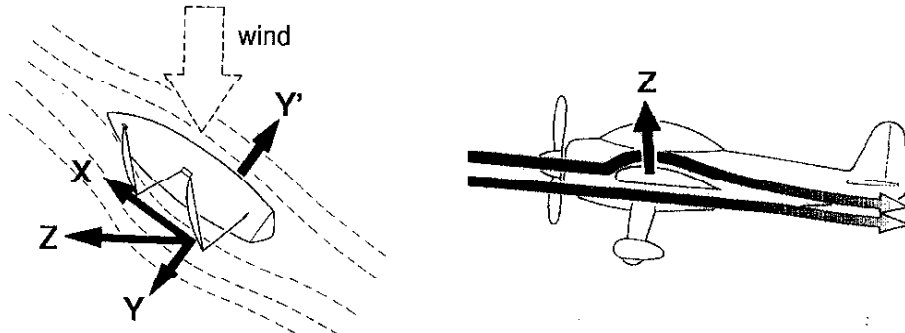

## Adjust the sail tack

When the wind is blowing hard, or when you wish to sail the yacht slowly, open the sail tack wide.

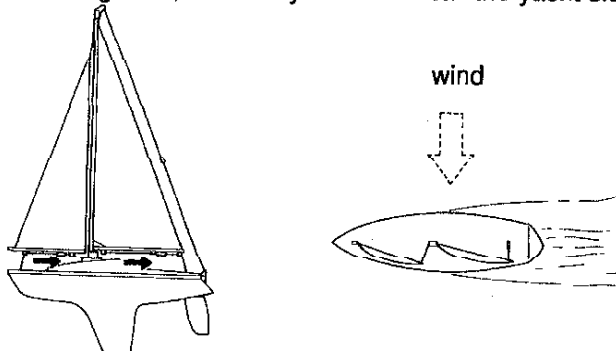

When there is a light or no wind, or when you wish to sail the yacht fast, keep the sail tack narrow.

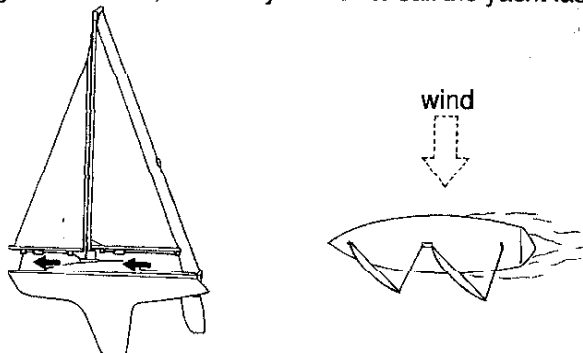

## Sailing technique

Use the rudder controller as illustrated below.

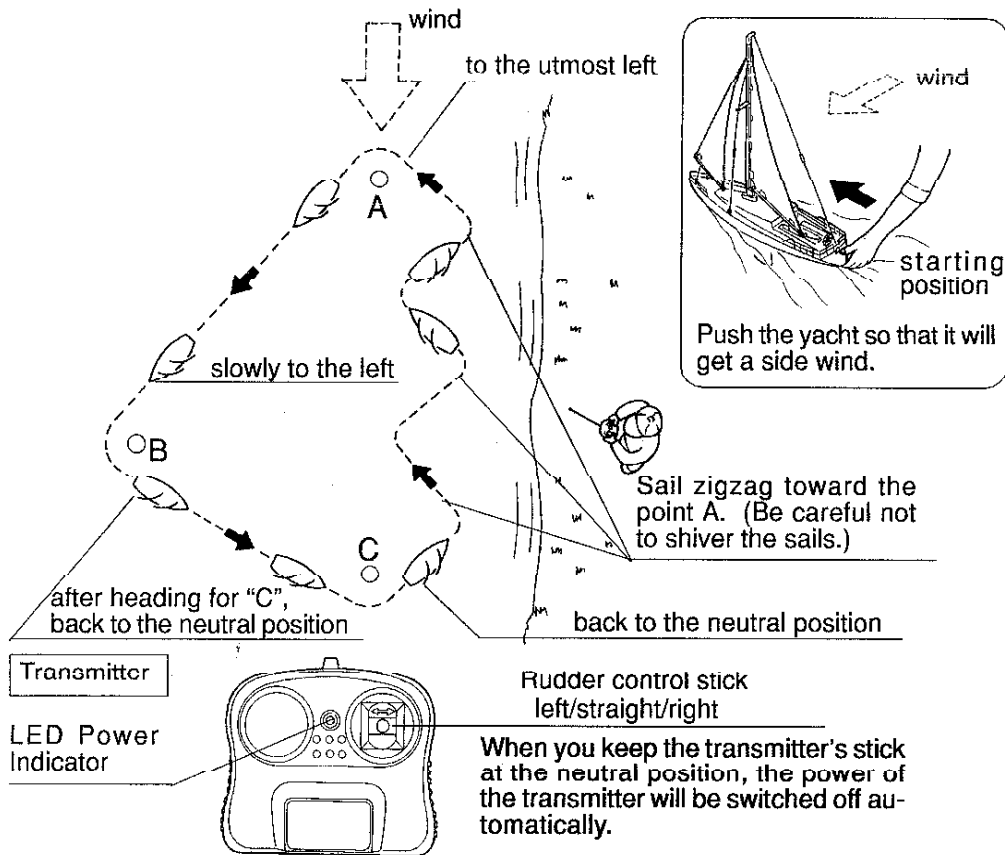

## Reconfirm the following before start sailing

- \*Choose a day with moderate winds, especially for the first try.
- \*For sailing, select such places as a lake, pond and marsh where there is no current. Rivers with current is undesirable for sailing because the yacht may be carried away.
- \*Control the yacht with confidence.
- \*Make sure that knots and snaps are firmly secured.
- \*Make sure that no other people are playing with RC items on your same frequency in your vicinity.
- \*To make a turn, let the sails catch a wind and operate the rudder controller quickly while the yacht is moving fast. If the yacht is not sailing with enough speed, you cannot make a desired turn because the effect of the rudder is unable to overcome the wind.
- \*When it has become windy, take back the yacht without delay.

## How to play

You can sail the yacht for approximately 60 minutes. The battery life depends on how much you use the rudder controller. Try to bring back the yacht ashore before the batteries run out.

- ① Extend the transmitter antenna to its full length.

You can control the yacht at a longer distance by holding the transmitter higher with the antenna straight up.



- ② Check the direction and the velocity of the wind by the ribbon.

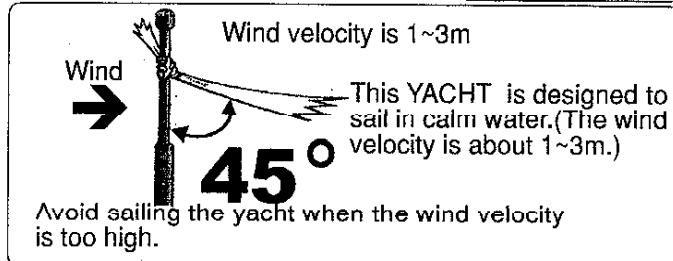

- ③ Turn the power switch of the yacht "ON".



- ④ Turn ON the transmitter by operating the transmitter. (The LED lamp will glow.)  
Check to see whether the rudder moves exactly as you move the control stick.

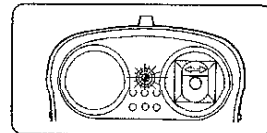

- ⑤ Start operating the yacht. Set the yacht afloat and push in such a way it will get the wind from the side. See "Sailing technique".

- ⑥ When you finished with the yacht, turn the power switch of the yacht "OFF".

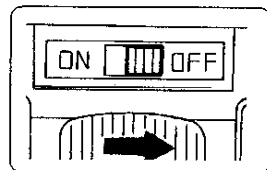

- ⑦ After playing, bring the boat to a dry place remove the batteries from the boat and the transmitter, drain all the water out of the hull, and dry the boat well before putting it away.

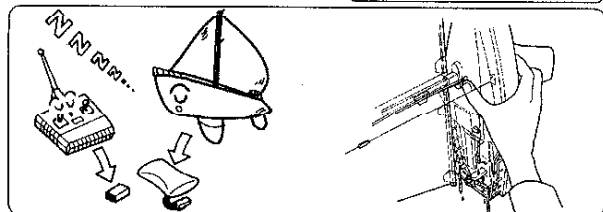

## Safety rules

- Do not sail the yacht in a pond or marsh where such obstacles as plants, rubbish and junk are floating. They will damage the yacht.
- Do not play where there is a strong current or wind.
- Do not play in the sea water.
- Do not play when it is thundering.
- Bring back the yacht to the shore before the batteries run out.

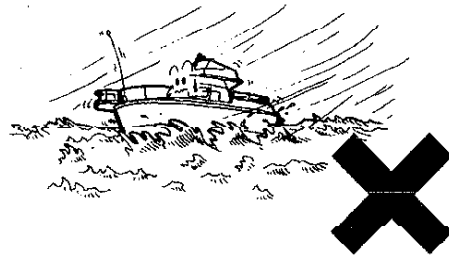
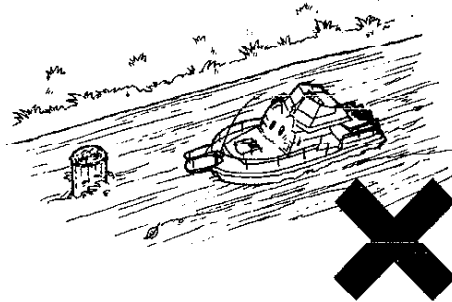

### Warning:

The RC yacht should be played at the water's edge of a lake or ponds. Make sure that the yacht is operated in a safe place so that neither the operator nor accompanying persons meet with any accidents.

## Maintenance

- When you have finished, dry up the yacht with a dry towel.
- Do not use chemicals. They may transform or damage the yacht.

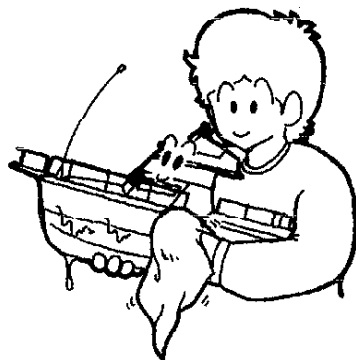

After playing, remove all batteries from the yacht and the transmitter, drain the water out of the hull, and dry the yacht well before storing.

## **SAFETY PRECAUTIONS**

1. Please read instructions book carefully before operating this Yacht.
2. Adult supervision is recommended. Keep out of reach of very young children.
3. Children should be made aware of the dangers associated with playing near water.
4. Ensure both Yacht and Transmitter Unit are turned off before attempting to pick up Yacht.
5. Please keep these instructions for future reference.
6. Never attempt any repair as may invalidate your guarantee.

### **BATTERY CAUTION SHEET (NO D.C. JACK)**

(E)

- Check the batteries regularly for leakage.
- Remove empty batteries from the toy.
- Never try to charge non-rechargeable batteries.
- Removable batteries which can be recharged must be removed from the toy prior to charging.
- Rechargeable batteries may only be charged under the supervision of an adult.
- When inserting the batteries take care not to reverse their polarity.
- Never Use batteries of different manufacturers, and do not mix old and new batteries.
- Use only the recommended batteries or batteries of equal quality.
- Never short-circuit the terminals.

**Cleaning and maintenance:**

This toy yacht needs periodic maintenance and cleaning.

**Warning to the parents**

The charger for the Ni-Cd battery pack needs periodic inspection to see that the lead wires, plugs, outer case, and other parts are not damaged in any way. If any of the parts are damaged, do not use the charger until it is completely repaired.

**Caution**

Keep out of reach of small children under 36 months old as there is danger of getting hurt.



**THE RBRC™ Seal on the nickel cadmium battery pack indicates that NikkoAmerica is voluntarily participating in an industry program to collect and recycle these batteries at the end of their useful life. The RBRC program provides a convenient alternative to disposing nickel-cadmium batteries into the trash or municipal waste stream, which is illegal in some areas.**

**Nikko America's payments to RBRC makes it easy for you to drop off the spent battery pack at local retailers who sell replacement nickel-cadmium batteries.**

**You may also contact your local recycling center for information on where to return the spent battery pack.**

**RBRC is a trademark of the Rechargeable Battery Recycling Corporation.**

**THE FCC WANTS YOU KNOW**

This device complies with part 15 of the FCC Rules, Operation is subject to the following two conditions:

- (1) This device may not cause harmful interference.
- (2) This device must accept any interference received, including interference that may cause undesired operation.

Your R/C boat might cause TV or radio interference even when it is operating properly.

To determine whether your R/C boat is causing the interference, turn off your R/C boat.

If the interference goes away, your R/C boat is causing the interference.

Try to eliminate the interference by:

- Moving your R/C boat away from the receiver.
- Contacting your local store for help.

If you cannot eliminate the interference, the FCC requires that you stop using your R/C boat.

**CAUTION:**

**Changes or modifications not expressly approved by the manufacturer for compliance could void the user's authority to operate the equipment.**