

RS 501

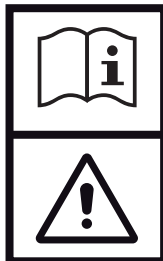

ENGLISH

SERVICE MANUAL

TABLE OF CONTENTS

GENERAL INFORMATION	3
MACHINE LIFTING	3
MACHINE TRANSPORT	3
PUSHING OR TOWING THE MACHINE.....	3
OTHER AVAILABLE MANUALS	3
SAFETY	3
GENERAL SAFETY INSTRUCTIONS	4
TECHNICAL DATA.....	6
ENVIRONMENTAL CONDITIONS.....	8
MAINTENANCE.....	9
SCHEDULED MAINTENANCE TABLE	9
MACHINE NOMENCLATURE	11
SWEEPING SYSTEM	17
DESCRIPTION	17
TROUBLESHOOTING.....	18
SIDE BROOM POSITION CHECK AND ADJUSTMENT.....	19
BROOM REPLACEMENT	21
BROOM SPEED ADJUSTMENT	22
DUST AND DEBRIS COLLECTION SYSTEM	23
DESCRIPTION	23
TROUBLESHOOTING.....	25
HOPPER, FILTER AND SUCTION HOSE CLEANING, AND GASKET CHECK.....	26
SUCTION INLET AND SKIRT HEIGHT AND OPERATION CHECK	29
SUCTION INLET WHEEL DISASSEMBLY/ASSEMBLY.....	31
SUCTION INLET SLIDING PANELS DISASSEMBLY/ASSEMBLY	32
SUCTION INLET DISASSEMBLY/ASSEMBLY	33
SKIRT REPLACEMENT	34
HOPPER POSITION ADJUSTMENT.....	35
HOPPER LID CLOSING ACTUATOR ADJUSTMENT.....	37
MOTOR AND SUCTION FAN DISASSEMBLY/ASSEMBLY.....	39
SUCTION HOSE DISASSEMBLY/ASSEMBLY	41
DUST CONTROL SYSTEM	43
DESCRIPTION	43
TROUBLESHOOTING.....	44
NOZZLE AND FILTER CLEANING	45
WATER FILTER CLEANING.....	47
WATER TANK EMPTYING	48
STEERING SYSTEM	49
DESCRIPTION	49
TROUBLESHOOTING.....	50
REAR AXLE TOE-IN ADJUSTMENT.....	51
BRAKE SYSTEM	53
DESCRIPTION	53
TROUBLESHOOTING.....	54
BRAKE FLUID LEVEL CHECK.....	55
PARKING BRAKE CHECK AND ADJUSTMENT.....	56
PARKING BRAKE CONTROL CABLE REPLACEMENT.....	57
BRAKE SYSTEM CHECK	59
BRAKING MASSES REPLACEMENT.....	60
BRAKE SYSTEM BLEEDING.....	61
DRIVE SYSTEM	63
DESCRIPTION	63
TROUBLESHOOTING.....	64
TIRE PRESSURE CHECK	65
REVERSE GEAR BUZZER CHECK AND REVERSE GEAR BUZZER ACTIVATION SENSOR ADJUSTMENT	66
REVERSE GEAR BUZZER SENSOR DISASSEMBLY/ASSEMBLY.....	67
WHEEL REMOVAL/INSTALLATION.....	68
DRIVE SYSTEM MOTOR DISASSEMBLY/ASSEMBLY.....	69
DRIVE PEDAL CHECK AND ADJUSTMENT	70

LDW 1603/B2 ENGINE	73
DESCRIPTION	73
TROUBLESHOOTING	74
ENGINE OIL LEVEL CHECK	75
ENGINE OIL CHANGE	76
ENGINE OIL FILTER CHANGE	77
ENGINE COOLANT LEVEL CHECK	78
ENGINE AIR FILTER CLEANING	79
FUEL FILTER REPLACEMENT	80
FUEL FITTING AND SCREW CHECK	81
ALTERNATOR BELT TENSION CHECK	82
ALTERNATOR BELT REPLACEMENT	83
RADIATOR FIN CLEANING CHECK	84
ENGINE COOLANT LINE SLEEVE CHECK	85
ENGINE COOLANT CHANGE	86
INJECTOR CALIBRATION AND CLEANING	87
CLIMATE CONTROL SYSTEM	89
DESCRIPTION	89
TROUBLESHOOTING	90
COMPRESSOR BELT TENSION CHECK (LDW 1603/B2 engine)	91
COMPRESSOR BELT REPLACEMENT (LDW 1603/B2 engine)	92
AIR FILTER REPLACEMENT	93
OTHER SYSTEMS	95
NUT AND SCREW TIGHTENING AND LEAKAGE CHECK	95
LUBRICATION	96
CHECK AND ADJUSTMENT OF SENSOR FOR ENGINE START-UP INHIBITION WHEN THE DRIVE PEDAL IS PRESSED	97
DISASSEMBLY/ASSEMBLY OF SENSOR FOR ENGINE START-UP INHIBITION WHEN THE DRIVE PEDAL IS PRESSED	98
HYDRAULIC SYSTEM	99
DESCRIPTION	99
COMPONENT LOCATION	99
HYDRAULIC DIAGRAM	101
TROUBLESHOOTING	103
HYDRAULIC SYSTEM OIL LEVEL AND DRAIN FILTER EFFICIENCY CHECK	104
HYDRAULIC SYSTEM OIL CHANGE	105
HYDRAULIC SYSTEM OIL SUCTION FILTER REPLACEMENT	107
HYDRAULIC SYSTEM OIL DRAIN FILTER REPLACEMENT	108
DRIVE SYSTEM PUMP OIL FILTER REPLACEMENT	109
HYDRAULIC SYSTEM OIL COOLER FIN CLEANING CHECK	110
REAR WHEEL CONTROL HYDRAULIC CYLINDER DISASSEMBLY/ASSEMBLY	111
HYDRAULIC CYLINDERS DISASSEMBLY/ASSEMBLY	112
SUCTION FAN CONTROL VALVE ASSEMBLY REMOVAL/INSTALLATION	114
ACCESSORY SYSTEM CONTROL VALVE ASSEMBLY REMOVAL/INSTALLATION	115
ACCESSORY AND STEERING SYSTEM PUMP DISASSEMBLY/ASSEMBLY (LDW 1603/B2 engine)	116
SUCTION FAN PUMP DISASSEMBLY/ASSEMBLY	120
DRIVE SYSTEM PUMP DISASSEMBLY/ASSEMBLY	121
HYDRAULIC SYSTEM OIL PRESSURE CHECK AT THE SUCTION FAN PUMP	122
HYDRAULIC SYSTEM OIL PRESSURE CHECK AT THE ACCESSORY AND STEERING SYSTEM PUMP	124
HYDRAULIC SYSTEM OIL PRESSURE CHECK ON DRIVE SYSTEM PUMP	126
ELECTRICAL SYSTEM	129
DESCRIPTION	129
COMPONENT LOCATION	129
WIRING DIAGRAM	133
TROUBLESHOOTING	137
BATTERY FLUID LEVEL CHECK	138
FUSE REPLACEMENT	139
RELAY REPLACEMENT	140
CONTROL PANEL DISPLAY REPLACEMENT	141
LOW BEAM AND HIGH BEAM ADJUSTMENT AND BULB REPLACEMENT	142

GENERAL INFORMATION

**NOTE**

Forward, backward, front, rear, left or right are intended with reference to the operator's position, while on the driver's seat.

MACHINE LIFTING

**WARNING!**

Do not work under the lifted machine without supporting it with safety stands.

MACHINE TRANSPORT

(See User Manual)

**WARNING!**

Before transporting the machine, make sure that:

- All lids and covers are closed.
- All moving parts are stopped.
- The ignition key is removed.
- The machine is securely fastened to the means of transport.

PUSHING OR TOWING THE MACHINE

**WARNING!**

When pushing or towing the machine, carefully follow the relevant instructions given in the User Manual. Failure to follow these instructions may cause damage to the machine.

OTHER AVAILABLE MANUALS

The following Manuals are available at Nilfisk Literature Service Department:

- RS 501 Spare Parts List – Nilfisk Form Number 33015502
- RS 501 User Manual – Nilfisk Form Number 33015501

SAFETY

The following symbols indicate potentially dangerous situations. Always read this information carefully and take all necessary precautions to safeguard people and property.

**DANGER!**

It indicates a dangerous situation with risk of death for the operator.

**WARNING!**

It indicates a potential risk of injury for people or damage to objects.

**CAUTION!**

It indicates a caution related to important or useful functions.

Pay careful attention to the paragraphs marked by this symbol.

**NOTE**

It indicates a remark related to important or useful functions.

**CONSULTATION**

It indicates that it is necessary to consult the User Manual before performing any procedure.

GENERAL INFORMATION

GENERAL SAFETY INSTRUCTIONS

Specific warnings and cautions to inform about potential damages to people and machine are shown below.



DANGER!

- ***This machine must be used by properly trained and authorised personnel only.***
- ***Moreover, the operator must:***
 - ***Be of full age***
 - ***Have a driving license***
 - ***Be in normal psycho-physical conditions***
 - ***Not be under the effect of substances that alters the nervous system (alcohol, psychopharmaceuticals, drugs, etc.)***
- ***Before performing any maintenance/repair procedure remove the ignition key, engage the parking brake and disconnect the battery.***
- ***Do not wear jewels when working near electrical components.***
- ***Do not work under the lifted machine without supporting it with safety stands.***
- ***When working under open hoods/lids, make sure that they cannot be closed by accident.***
- ***When performing maintenance procedures with the lifted hopper, apply the relevant support rods.***
- ***Do not operate the machine near toxic, dangerous, flammable and/or explosive powders, liquids or vapors.***
- ***Be careful, fuel is highly flammable.***
- ***Do not smoke or bring naked flames in the area where the machine is refuelled or where the fuel is stored.***
- ***Refuel outdoors or in a well-ventilated area, with the engine off.***
- ***Do not fill the fuel tank to the top, but leave at least 4 cm from the filler neck to allow the fuel to expand.***
- ***After refuelling, check that the filler cap is tightly closed.***
- ***If any fuel is spilled while refuelling, clean up the affected area and allow the vapors to dissipate before starting the engine.***
- ***Avoid contact with skin and do not breathe in fuel vapors. Keep out of reach of children.***
- ***Do not tilt the engine too much to avoid fuel spillage.***
- ***During machine transportation, the fuel tank must not be full.***

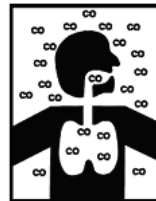

WARNING!

Carbon monoxide (CO) can cause brain damage or death.

The internal combustion engine of this machine can emit carbon monoxide.

Do not inhale exhaust gas fumes.

Only use indoors when adequate ventilation is provided, and when an assistant has been instructed to look after you.

- ***Do not lay any object on the engine.***
- ***Before working on the engine turn it off. To prevent the engine from starting accidentally, disconnect the battery negative terminal.***
- ***See also the SAFETY RULES in the Diesel Engine Manual, which is to be considered an integral part of this Manual.***

GENERAL INFORMATION**WARNING!**

- *Carefully read all the instructions before performing any maintenance/repair procedure.*
- *Take all necessary precautions to prevent hair, jewels and loose clothes from being caught by the machine moving parts.*
- *Protect body parts (eyes, hair, hands, etc.) properly, when performing cleaning procedures using compressed air or water gun.*
- *Avoid contact with battery acid, do not touch hot parts.*
- *Do not leave the machine unattended with the ignition key inserted and the parking brake deactivated.*
- *Do not remove or modify the plates affixed to the machine.*
- *To drive on public roads, the machine must follow local licensing requirements.*
- *The machine has been designed to be used as a sweeper, do not use it for different purposes.*
- *In case of part replacement, order ORIGINAL spare parts from an authorised Dealer or Retailer.*
- *The machine must be disposed of properly, because of the presence of toxic-harmful materials (batteries, etc.), which are subject to standards that require disposal in special centres (see the Scrapping chapter).*
- *While the engine is running the silencer heats up. Do not touch the silencer to avoid serious scalding or fire.*
- *Do not run the engine if the oil level is low, to avoid damaging it seriously. Check the oil level with the engine off and the machine on a level surface.*
- *Do not run the engine if the air filter is not installed, to avoid damaging it.*
- *The coolant line is pressurised; do not perform any check until the engine has cooled down and, even if the engine is cold, the tank plug must be opened with extreme care.*
- *Only use original spare parts or parts of matching quality for the diesel engine. Using spare parts of lower quality can seriously damage the engine.*
- *See also the SAFETY RULES in the Diesel Engine Manual, which is to be considered an integral part of this Manual.*

GENERAL INFORMATION**TECHNICAL DATA**

Dimensions and weights	Values
Machine length (broom bristles not included)	3,065 mm
Machine width (broom bristles not included)	1,315 mm
Distance between front and rear wheels	1,475 mm
Front wheel base	930 mm
Rear wheel base	840 mm
Machine height	1,997 mm
Minimum distance from the ground (skirts not included)	90 mm
Maximum front working angle	18°
Maximum dumping height	1,460 mm
Front tires	R165/70 R14C 89R
Rear tires	R165/70 R14C 89R
Tire pressure	3.75 Bar
Standard side broom diameter	720 mm
Optional side broom diameter	650 mm
Total machine weight, in running condition (without operator)	1,500 Kg

Performance data	Values
Maximum forward speed (for transport only)	20 km/h
Maximum working speed	12 km/h
Maximum reverse speed	8 km/h
Gradeability at full load	22% (30% optional)
Minimum inner turning radius	2.46 m
Maximum side broom speed	80 rpm
Collection system	Suction
Cleaning width	1,600 mm
Filtering system	Metallic net
Sound pressure level at workstation (ISO/EN 3744) at maximum working speed	82 dB(A)
Certified sound power (2000/14/EC) at maximum working speed	108 dB(A)
Measured sound power (ISO/EN 3744) at maximum working speed	106 dB(A)
Hopper capacity	500 liters
Hopper maximum load	380 Kg
Dust control	By water
Dust control system tank total capacity (No. 2)	240 liters
Lighting and signalling system	Road type
Transmission	Hydrostatic servoassisted
Steering system	On the rear axle, power assisted
Brake	Hydraulic
Parking brake	Mechanic
Controls	Hydraulic

GENERAL INFORMATION

LDW 1603/B2 diesel engine data (*)	Values
Make	Lombardini
Type	LDW 1603/B2
Cylinders	3
Maximum speed	2,600 rpm
Maximum working speed	2,200 rpm
Maximum power at 2,600 rpm	25 kW
Idle speed	900 rpm
Consumption while operating at 2,200 rpm	5.0 L/h
Consumption while operating at 2,600 rpm	5.9 L/h
Engine coolant	50% antifreeze AGIP and 50% water (**)
Engine oil type	AGIP Sigma Turbo 15W/40 (***)

(*) For other diesel engine data/values, see the relevant Manual.

(**) See the coolant technical data and reference data tables below.

SPECIFICATIONS		
Boiling point	°C	170
Boiling point in solution with 50% water	°C	110
Freezing point in solution with 50% water	°C	-38
Color	/	Turquoise blue
Density at 15°C	kg/l	1.13

(***) See the engine oil technical data and reference data tables below.

SPECIFICATIONS		
SAE QUALITY	/	15W40
Viscosity at 100°C	mm ² /s	13.7
Viscosity at 40°C	mm ² /s	100
Viscosity at -15°C	mm ² /s	3,300
Viscosity index	/	138
Flash point COC	°C	230
Pour point	°C	-27
Density at 15°C	kg/l	0.885

Refuelling data	Values
Fuel tank capacity	30 liters
Hydraulic system oil tank capacity	40.6 liters
Hydraulic system capacity	58 liters

Electrical system data	Values
System voltage	12 V
Starting battery	12 V – 80 Ah

REFERENCE DATA		
CUNA NC 956-16 97		
FF.SS cat. 002/132		
ASTM D 1384		

REFERENCE DATA		
ACEA E3-96		
API Service CG-4/SG		
CCMC D5, PD-2		
US Department of the Army MIL-L-2104 E		
US Department of the Army MIL-L-46152 E		
MACK EO-L		
MAN M 3275		
Mercedes Benz 228.3		
VOLVO VDS2		
MTU typ 2		

GENERAL INFORMATION

Hydraulic system data	Values
Maximum drive system pressure	250 Bar
Maximum accessory system pressure	120/200 Bar
Hydraulic system oil type (at ambient temperature above 10°C)	AGIP Arnica 46 (****)



NOTE

If the machine is to be used at ambient temperatures below 10°C, the oil should be replaced with equivalent oil having a viscosity of 32 cSt. For temperatures below 0°C, use oil with lower viscosity.

(****) See the below hydraulic system oil technical data and reference data tables.

TECHNICAL DATA			
AGIP ARNICA		46	32
Viscosity at 40°C	mm ² /s	45	32
Viscosity at 100°C	mm ² /s	7.97	6.40
Viscosity index	/	150	157
Flash point COC	°C	215	202
Pour point	°C	-36	-36
Density at 15°C	kg/l	0.87	0.865

REFERENCE DATA
ISO-L-HV
ISO 11158
AFNOR NF E 48603 HV
AISE 127
ATOS Tab. P 002-0/I
BS 4231 HSE
CETOP RP 91 H HV
COMMERCIAL HYDRAULICS
Danieli Standard 0.000.001 (AGIP ARNICA 22, 46, 68)
EATON VICKERS I-286-S3
EATON VICKERS M-2950
DIN 51524 t.3 HVLP
LAMB LANDIS-CINCINNATI P68, P69 and P70
LINDE
PARKER HANNIFIN (DENISON) HF-0
REXROTH RE 90220-1/11.02
SAUER-DANFOSS 520L0463

ENVIRONMENTAL CONDITIONS

In the environment where the machine operates, there must not be any danger of explosion.

To avoid inhaling exhaust gas, the machine must be used only where there is a proper air change.

The machine operates correctly (*) in the following environmental conditions:

- Temperature: -10°C to +40°C
- Humidity: 30% to 95%, not condensed

Store the machine indoor, in a clean and dry place, protected from bad weather conditions and with the following values:

- Temperature: +1°C to +50°C
- Humidity: maximum 95%, not condensed

(*) When using the sweeper at a temperature between -10°C and 0°C the dust control system cannot be used; moreover the water tanks and the dust control system itself must be empty.

GENERAL INFORMATION

MAINTENANCE

The lifespan of the machine and its maximum operating safety are ensured by correct and regular maintenance.

**WARNING!**

See **GENERAL INFORMATION** and **SAFETY** paragraphs.

The following table provides the scheduled maintenance. The intervals shown may vary according to particular working conditions, which are to be defined by the person in charge of the maintenance.

The instructions relating to the maintenance procedures given in the following table are described in the next paragraphs.

SCHEDULED MAINTENANCE TABLE

Maintenance	Running-in period (after the first 50 hours)	Every 10 hours or before use	Every 200 hours	Every 600 hours	Every 1,200 hours	Every 2,400 hours	Long periods
Engine oil level check							
Engine air filter cleaning							
Engine radiator fin cleaning check							
Engine coolant level check							
Battery fluid level check							
Hydraulic system oil level and drain filter efficiency check							
Hydraulic system oil cooler fin check and cleaning							
Hopper, filter and suction hose cleaning, and gasket check							
Dust control system nozzle and filter cleaning							
Brake fluid level check							
Reverse gear buzzer operation check							
Diesel engine start-up safety system check							
Tire pressure check							
Suction inlet and skirt height and operation check							
Side broom position check and adjustment							
Engine oil change			(7)(8)				
Dust control system water filter cleaning							
Parking brake check							
Alternator belt tension check			(7)				
Climate control system compressor belt tension check							
Diesel engine oil filter replacement			(7)(8)				
Fuel filter replacement			(7)				
Nut and screw tightening and leakage check							

GENERAL INFORMATION

Maintenance	Running-in period (after the first 50 hours)	Every 10 hours or before use	Every 200 hours	Every 600 hours	Every 1,200 hours	Every 2,400 hours	Long periods
Lubrication							
Engine coolant line sleeve check			(7)				
Drive system pump oil filter check							
Hydraulic system oil drain filter replacement							
Hydraulic system oil suction filter replacement							
Alternator belt replacement				(3)			
Cab air filter replacement				(1)			
Injector calibration and cleaning					(2) (3)		
Climate control system belt replacement							
Engine coolant change					(3)		
Hydraulic system oil change					(3)		
Brake system check							
Hydraulic system pump pressure check							
Minor engine overhaul							(2) (4)
Major engine overhaul							(2) (5)

- (1) Or every 6 months
(2) Maintenance to be performed by Lombardini authorised Service Center
(3) Or every two years
(4) After 5,000 hours
(5) After 10,000 hours
(7) Every year, if the machine is not frequently used
(8) If a lower-quality oil is used, change it every 125 hours

GENERAL INFORMATION

MACHINE NOMENCLATURE

Throughout this Manual you will find numbers in brackets, for example: (2). These numbers refer to the components indicated in these two nomenclature pages. Refer to these pages whenever it will be necessary to identify a component mentioned in the text.

1. Cab
2. Left door
3. Hopper
4. Diesel engine
5. Suction fan
6. Flashing light
7. Dust control system left tank
8. Front fixed wheels
9. Rear steering wheels
10. Right side broom
11. Left broom
12. Suction inlet
13. Right door
14. Meter and control panel
15. Rear axle
16. Dust control system right tank
17. Rear suction pipe (*)
18. Left lid
19. Left lid fasteners
20. Right lid
21. Right lid fasteners
22. Cab right panel
23. Cab left panel
24. Right door handle
25. Left door handle
26. Hopper lid
27. Open lid support rod
28. Lifted hopper locking pins
29. Lifted hopper locking pins housing
30. Lifted hopper locking pins holes
31. Suction filter
32. Drain filter
33. Hydraulic system oil tank
34. Battery
35. Hydraulic system oil cooler
36. Suction inlet-to-hopper pipe
37. Fuel tank
38. Hopper manual lifting hand pump (to be used in case of engine malfunction)
39. Hydraulic system oil drain filter
40. Hopper lifting device
41. Dust control system left tank
42. Left tank mounting screw
43. Dust control system right tank
44. Right tank mounting screw
45. Front towing hook
46. Engine air filter
47. Fuel tank filler neck
48. Hopper support rods
49. Left water tank filler plug
50. Right water tank filler plug
51. Brake fluid tank
52. Windscreen wiper fluid tank
53. Windscreen wiper motor
54. Combination switch
55. Steering wheel adjusting lever
56. Drive pedal
57. Brake pedal
58. Steering wheel
59. Driver's seat
60. Suction inlet and brooms control lever
61. Driver's seat safety belt (*)
62. Hopper lifting/lowering lever
63. Suction activation lever
64. Cab heater control knob
65. Diesel engine throttle lever
66. Parking brake lever
67. Broom dust control system nozzle valve
68. Suction inlet dust control system nozzle valve
69. Skirt lifting switch
70. Lifted hopper warning light (red)
71. Hazard warning light switch
72. Dust control system switch
73. Cab blower switch
74. Windscreen wiper/washer switch
75. Climate control system switch (*)
76. Ignition key
77. Dust control system water tank warning light (red)
78. Warning buzzer (it activates together with the warning lights 87, 91, 93, 94)
79. Fuse box B
80. Fuse box A
81. Indicators and warning lights
82. Optional indicator light
83. Optional indicator light
84. Engine coolant temperature
85. High beam indicator light
86. Running light indicator light
87. Charged battery indicator light (together with the indicator light a buzzer activates with intermittent sound)
88. Parking brake indicator light (together with the indicator light a buzzer activates with continuous sound)
89. Glow plug pre-heating warning light
90. Hour counter/revolution counter display:
 - It displays the hours, when the ignition key (76) is turned on the first position, before running the engine;
 - It displays the engine speed, when the engine is running and the charged battery warning light is off.
91. Low fuel warning light (a buzzer activates together with the warning light)
92. Optional indicator light
93. Engine coolant high temperature warning light (a buzzer activates together with the warning light)
94. Engine oil pressure warning light (a buzzer activates together with the warning light)
95. Turn signal indicator light
96. Hopper lid opening/closing switch
97. Rear bumper
98. Diesel engine serial number/technical data plate (another plate showing the same data as the plate affixed on the diesel engine)(*)
99. High-pressure washing system hose with reel (*)
100. High-pressure water quick coupling (*)
101. Breather filter hood fasteners
102. Rear suction pipe fastener
103. Front skirt
104. Machine serial number
105. Hopper (dumping position)
106. Suction hose gasket

GENERAL INFORMATION

- 107. Hopper manual lifting hand pump lever
- 108. High-pressure water gun
- 109. Serial number plate/technical data/certification marking
- 110. Right water tank drain plug
- 111. Left water tank drain plug
- 112. High-pressure washing system pressure gauge
- 113. Breather filter hood
- 114. Hydraulic system oil filler plug
- 115. Hydraulic system pressure intake (on drive system pump)
- 116. Hydraulic system pressure intake (at suction fan pump)
- 117. Hydraulic system pressure intake (at accessory and steering system pump)
- 118. Hopper lid suction sealing gasket
- 119. Document holder
- 120. Hopper lifting/lowering lever safety flange
- 121. Suction inlet and broom lifting/lowering lever safety flange
- 122. Driver's seat forward/backward adjustment lever
- 123. Ashtray
- 124. High-pressure water gun sprinkler nozzle
- 125. Cigarette lighter
- 126. Can holder
- 127. Broom speed adjuster (***)
- 128. Hydraulic system oil level indicator

(*) Optional for some countries.

GENERAL INFORMATION

MACHINE NOMENCLATURE (Continues)

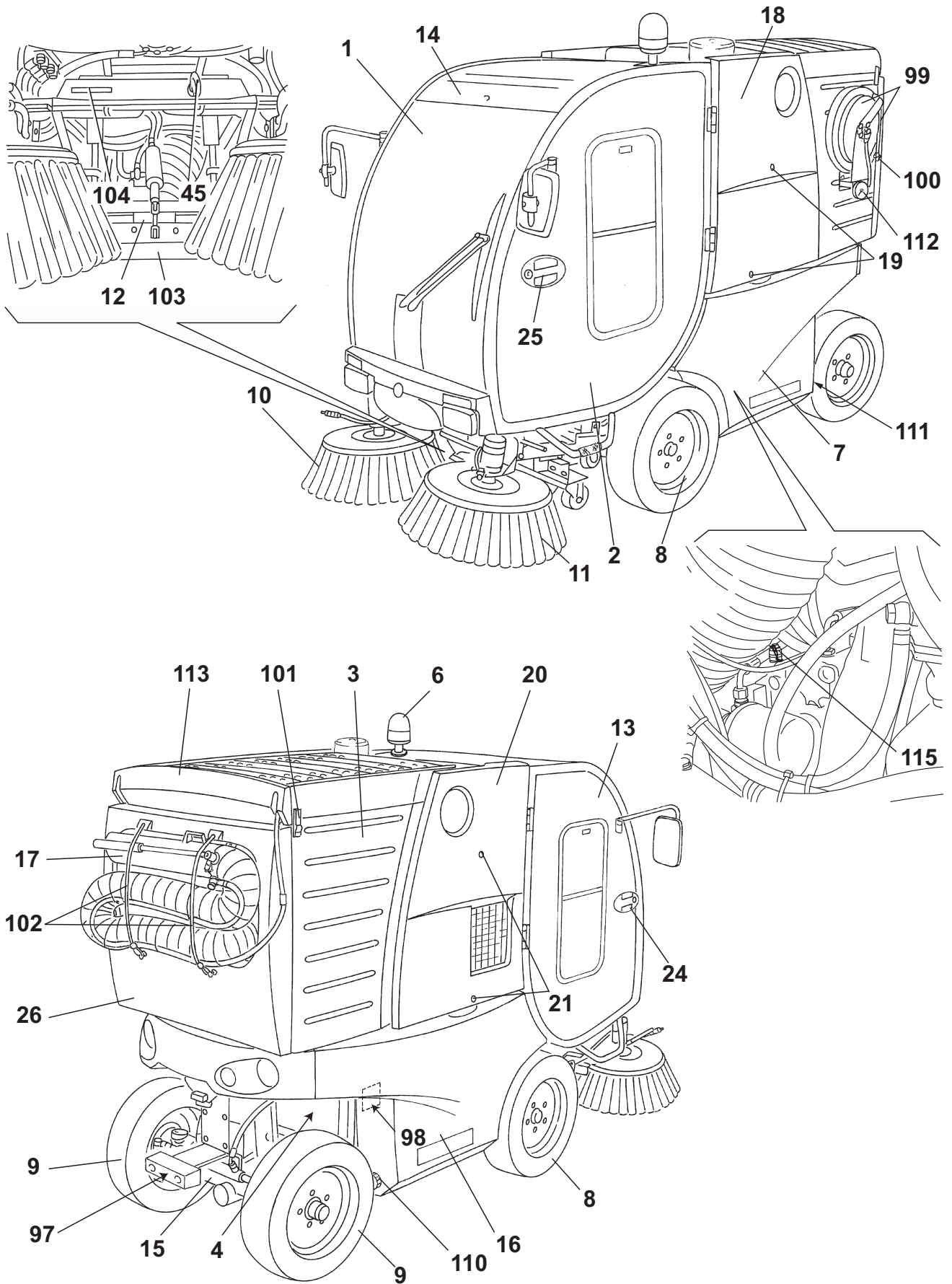

S301479

GENERAL INFORMATION

MACHINE NOMENCLATURE (Continues)

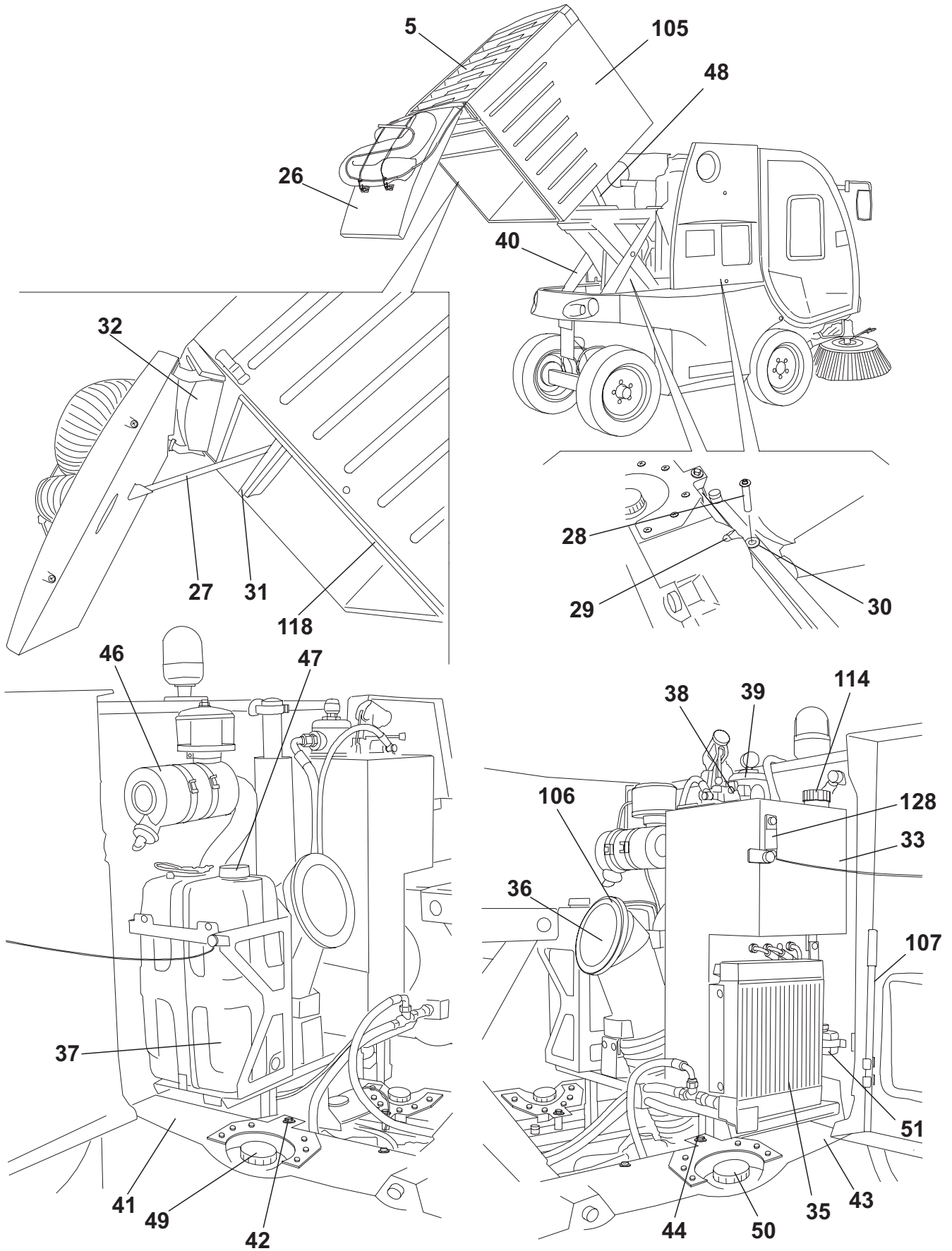

S301617

GENERAL INFORMATION

MACHINE NOMENCLATURE (Continues)

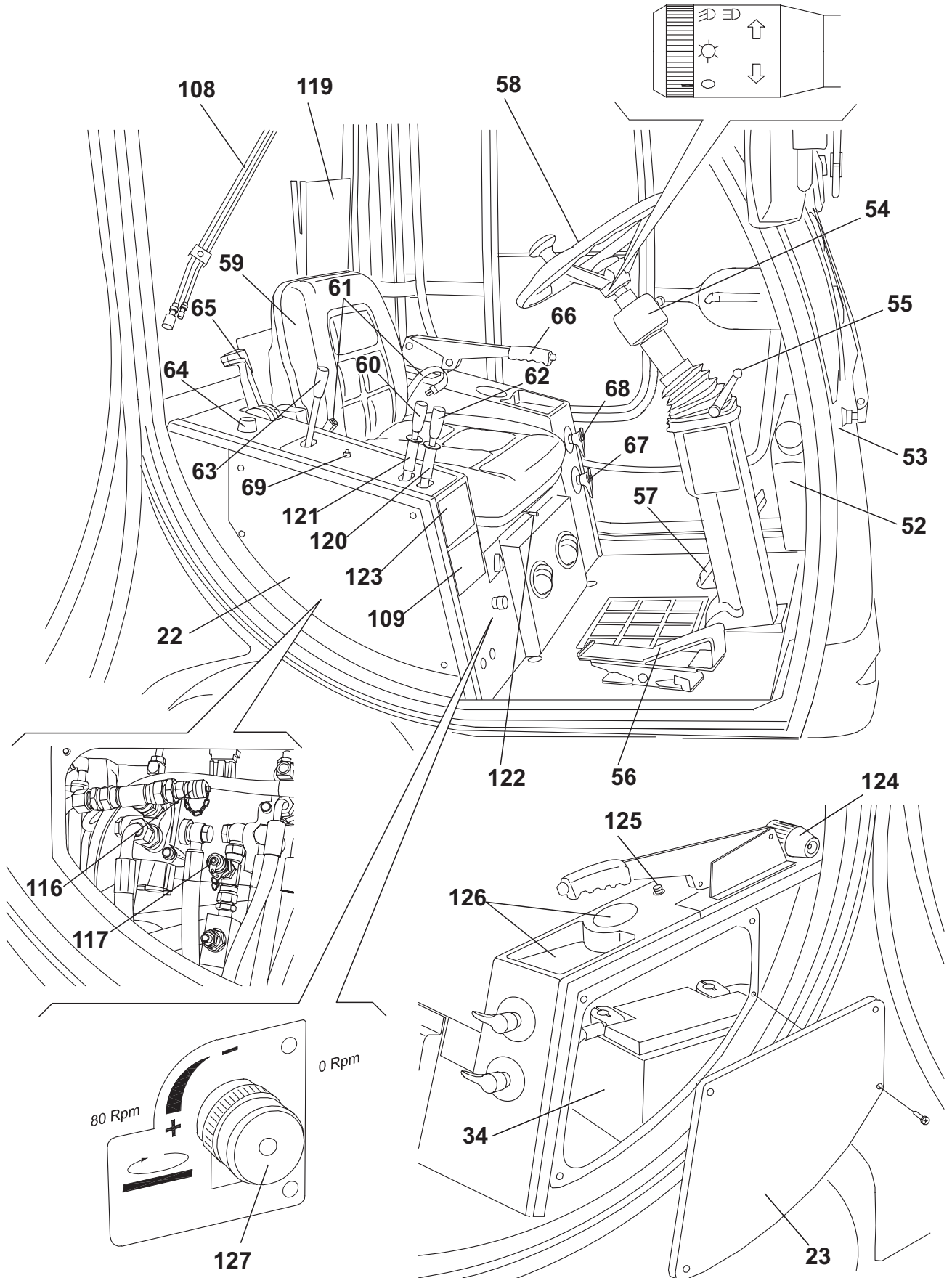

S301481

GENERAL INFORMATION

MACHINE NOMENCLATURE (Continues)

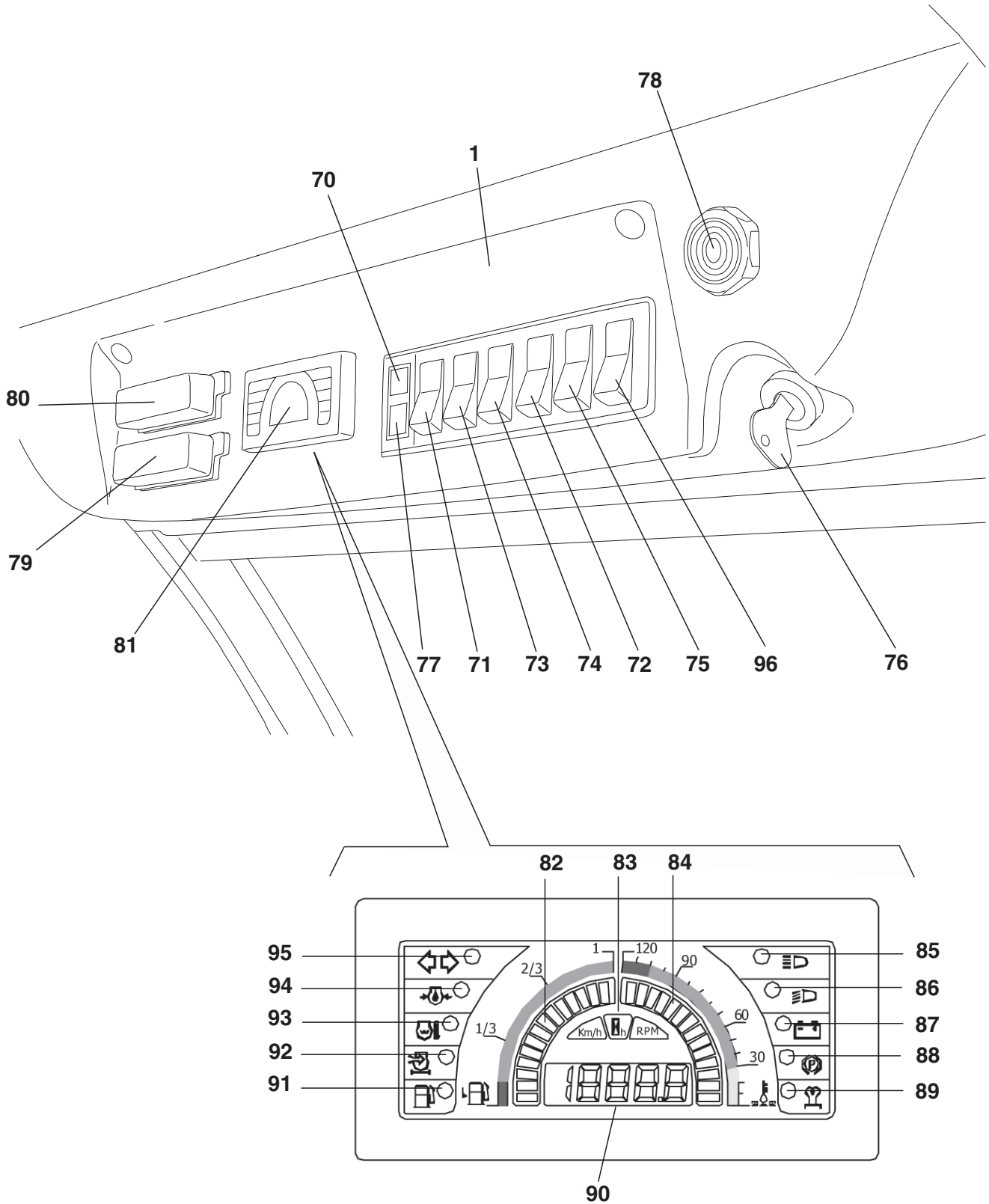

S301407

SWEEPING SYSTEM

DESCRIPTION

The sweeping system consists of:

- A) Right side broom
- B) Left broom
- C) Broom arms

The brooms (A) and (B) are supported by arms (C) which are fastened to the machine frame.

Broom rotation is activated by hydraulic motors.

For proper sweeping and conveyance of dust and debris towards the suction inlet:

- Broom height and tilting must be properly adjusted;
- Proper brooms must be used according to the type of ground to be cleaned. The following types are available:
 - Polypropylene brooms
 - Polypropylene and steel brooms



S300857

SWEEPING SYSTEM

TROUBLESHOOTING

The brooms do not clean correctly

Possible causes:

1. The brooms are not adjusted correctly (adjust).
2. The broom speed is not correct (adjust).

The brooms do not rotate

Possible causes:

1. There are oil leaks from the hydraulic system hoses (replace the hoses).
2. The hydraulic motors are faulty (replace).
3. The accessory system hydraulic pump does not pressurize the oil in the circuit (check the hydraulic system oil pressure).

SIDE BROOM POSITION CHECK AND ADJUSTMENT**NOTE**

Brooms of various hardness are available. This procedure is applicable to all types of brooms.

Check

1. Check the side brooms for proper height and tilting, according to the following procedure:
 - Drive the machine on a level ground.
 - While keeping the machine stationary, fully lower the side brooms and allow them to rotate for a few seconds.
 - Stop and lift the side brooms, then move the machine.
 - Check that the size and orientation of the prints left by the side brooms are as follows:
 - The right side broom must touch the ground along a circle arc (A) ranging from “11 o'clock” position to “4 o'clock” position.
 - The left side broom must touch the ground along a circle arc (B) ranging from “8 o'clock” position to “1 o'clock” position.

Adjust the broom height when the prints are out of specification, according to the following procedure.

2. Engage the parking brake with the lever (66).

3. Turn the ignition key (76) to OFF position and remove it.

Broom height adjustment

4. On both sides of the machine, operate on the tensioning self-locking nut (C) of the spring (D) and consider the following:
 - To lower the broom, the nut (C) must be unscrewed;
 - To lift the broom, the nut (C) must be screwed.
5. Perform step 1 again.

Broom forward tilting angle adjustment

6. On both sides of the machine, loosen the screws (E) and (F), then adjust the forward tilting angle (G).
When the adjustment is completed, tighten the screws (E) and (F).
7. Perform step 1 again.

Broom side tilting angle adjustment

8. On both sides of the machine, loosen the screws (I) and (L), then adjust the side tilting angle (H).
When the adjustment is completed, tighten the screws (I) and (L).
9. Perform step 1 again.

Broom side position adjustment

10. The purpose of this adjustment is to improve the side position of the brooms as to the suction inlet (12).
11. To perform the adjustment, loosen the nuts (J) and operate on the screw (K), thus changing the side position of the brooms.
12. When the side brooms are too worn out, the adjustment is not possible; replace the brooms according to the instructions in the relevant paragraph.

SWEEPING SYSTEM

SIDE BROOM POSITION CHECK AND ADJUSTMENT (Continues)

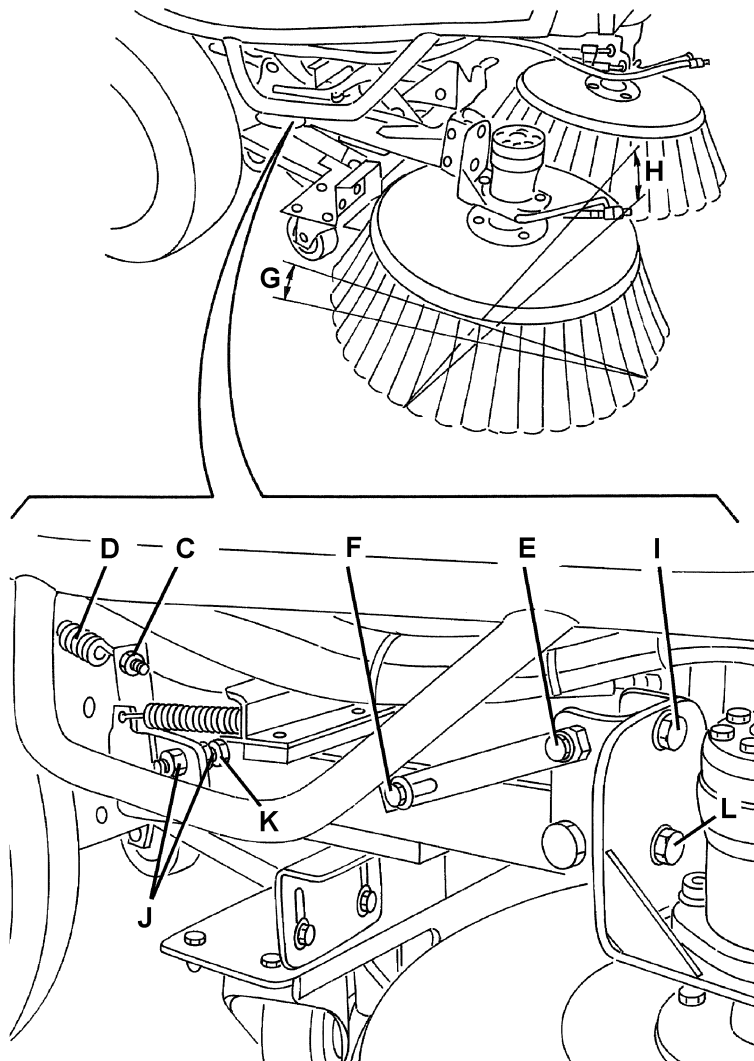
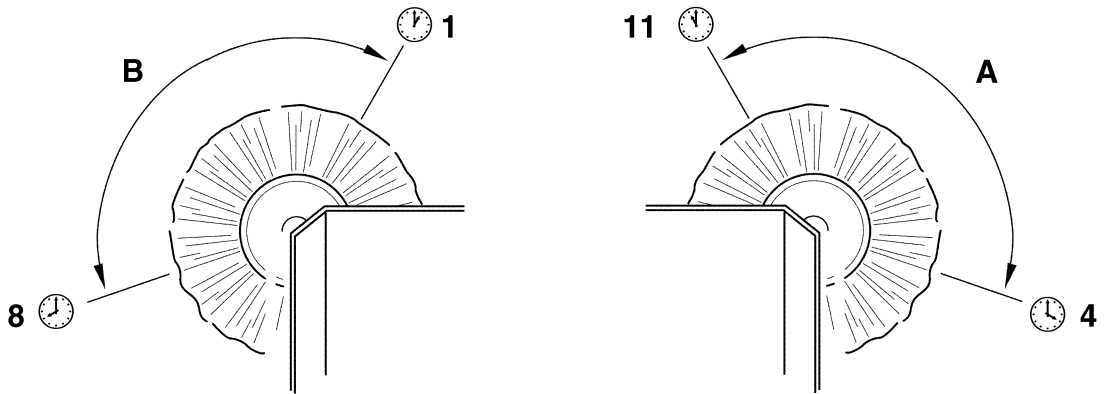

S301482

BROOM REPLACEMENT



NOTE

Brooms of various hardness are available. This procedure is applicable to all types of brooms.



CAUTION!

It is advisable to use protective gloves when cleaning the side brooms because there can be sharp debris between the bristles.

1. Lift the brooms and engage the parking brake with the lever (66).
2. Turn the ignition key (76) to OFF position and remove it.
3. Remove the centre screw (A), then remove the broom (B) to be replaced. Recover the key.
4. Remove the screws (D), then remove the flange (E).
5. Install the flange (E) and secure it on the new broom with the screws (D).
6. Install the new broom (B) with the key, then tighten the centre screw (A).
7. Adjust the height of the new broom according to the procedure shown in the previous paragraph.



B

A



B

B



D

E

D

S300859

SWEEPING SYSTEM

BROOM SPEED ADJUSTMENT

Speed measurement

1. Engage the parking brake with the lever (66).
2. Turn the ignition key (76) to OFF position and remove it.
3. Connect a speed measurement indicator with a portable tachometer to the broom (10) or (11).
4. Start the machine and run the engine at maximum speed and set the broom speed adjuster (127) to maximum speed (as shown in the User Manual). In this condition, measure the broom speed with the portable tachometer. Turn off the machine.
The broom speed must be: 80 rpm

If necessary, change the broom speed according to the following procedure.

Speed adjustment

5. Remove the screws and the right panel (22) in the cab.
6. To change the broom speed, loosen the locknut (A) and turn the screw (B), then tighten the locknut (A).
7. Perform step 4 again.

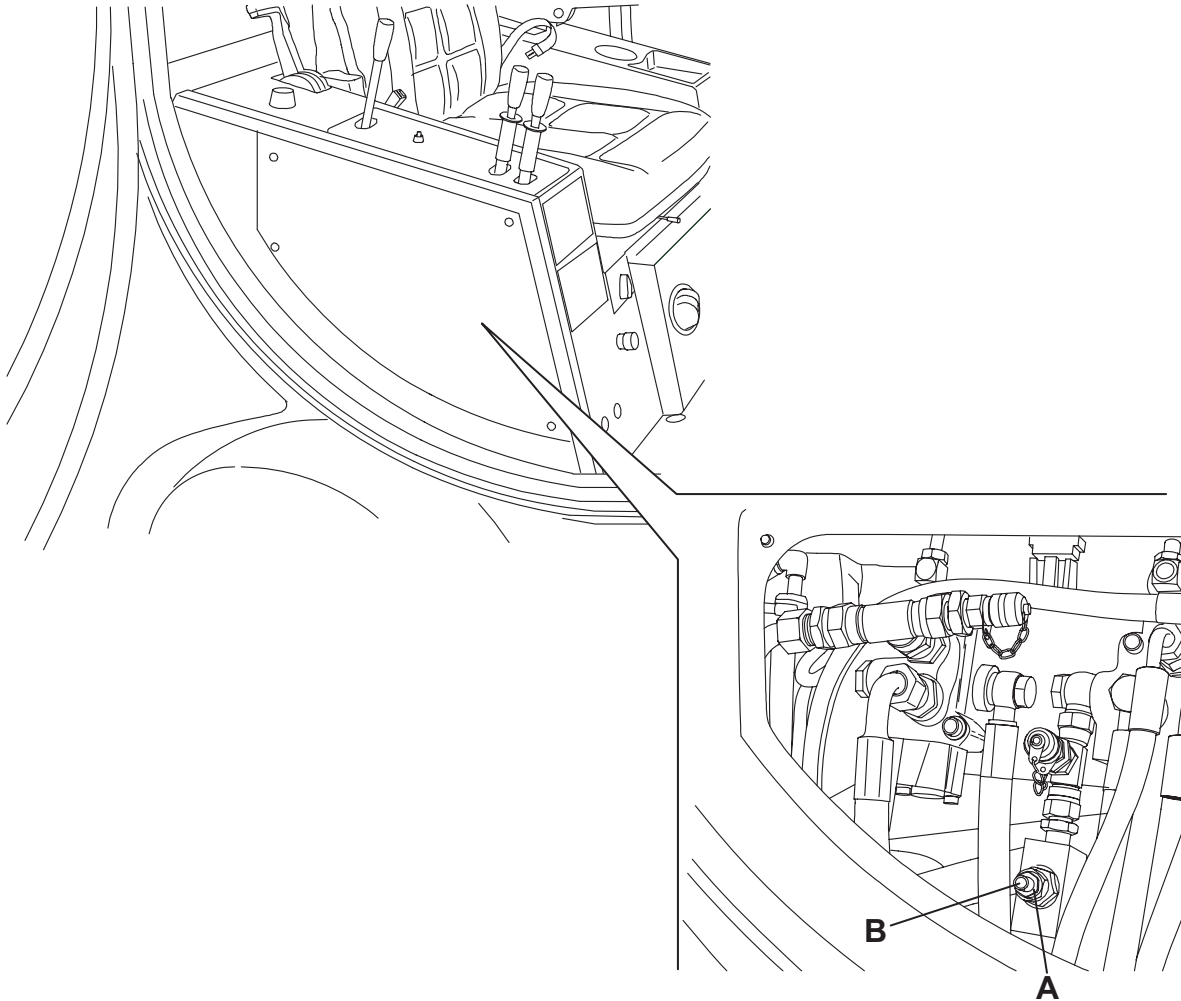

S301510

DUST AND DEBRIS COLLECTION SYSTEM**DUST AND DEBRIS COLLECTION SYSTEM****DESCRIPTION**

The dust and debris collection system consists of:

- A) Suction fan
- B) Dust and debris suction filter
- C) Hopper
- D) Suction hose
- E) Suction inlet
- F) Skirt
- G) Gasket between suction inlet and hopper
- H) Hopper lid
- I) Hopper suction hole
- J) Open lid support rod
- K) Lifted hopper locking pins
- L) Lifted hopper locking pins housing
- M) Lifted hopper locking pins holes
- N) Air breather filter
- Q) Hopper lid suction sealing gasket

The suction fan (A), activated by an hydraulic motor, creates vacuum inside the hopper (C). The vacuum determines the suction capacity of the suction inlet (E) through the suction hose (D).

The hopper (C) is made of steel.

It is fastened with two pins to a mechanic/hydraulic lifting system (O) (for hopper lifting) and to a dumping system (P) (for hopper tilting). The lid (H), which can be opened with an hydraulic control system, allows for debris discharging.

Both the lid (H) and the suction hole (I) are equipped with gaskets, which allow the suction inlet (E) to reach the maximum suction capacity.

Inside the hopper there are two stainless steel filters having the following functions:

- The suction filter (B) retains dust and debris during fan suction phase, and makes them settle in the hopper;
- The breather filter (N) retains dust and debris escaped from the suction filter, and does not allow them to be discharged externally.

Both filters can be easily removed and cleaned.

To perform checks and maintenance procedure safely with the hopper lifted and the lid opened, perform the following procedures:

- Turn the rod (J) to lock the lid (H) in open position.
- Remove the pins (K) from the housings (L) and place them into the holes (M) to lock the hopper (C) in lifted and dumped position.

The suction inlet is made of sheet steel.

It is equipped with three wheels, which allow it to follow the pattern of the surface to be cleaned.

On its front side there is a skirt (F) that must be lifted to collect bulky debris.

DUST AND DEBRIS COLLECTION SYSTEM

DESCRIPTION (Continues)

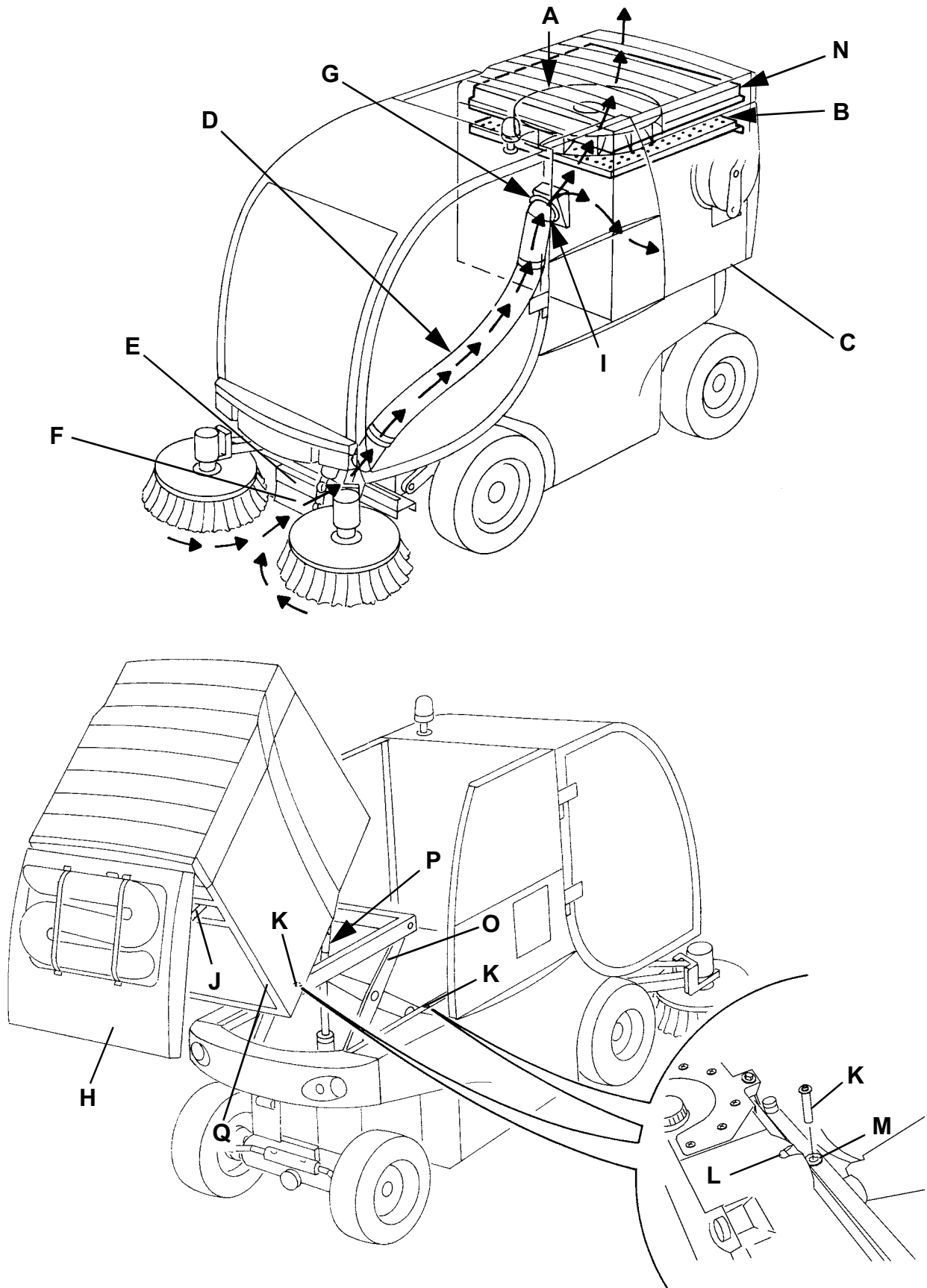

S301483

DUST AND DEBRIS COLLECTION SYSTEM**TROUBLESHOOTING****The suction fan turns but it is not efficient**

Possible causes:

1. The filters are clogged (clean).
2. The suction hose is clogged (clean).
3. The suction hose is cut/torn (replace).
4. The gasket between the suction inlet and the hopper is broken or misadjusted (replace or adjust).
5. The hopper lid gasket is broken (replace).
6. There is no pressure at the suction fan motor drive pump (adjust the pump pressure).

The suction fan does not turn

Possible causes:

1. The motor is faulty (replace).
2. The control valve assembly is stuck (repair).
3. The pump is faulty (replace).

The suction inlet does not collect debris efficiently

Possible causes:

1. The suction inlet position is incorrect (check the suction inlet and skirt height and efficiency).

The skirt opening force is not sufficient

Possible causes:

1. The skirt opening pressure is incorrect (adjust).

The hopper does not lift/lower

Possible causes:

1. The control valve assembly is stuck (repair).
2. The cylinder gaskets are worn (repair the cylinder).

The rear lid does not open/close

Possible causes:

1. There is no voltage in the actuator (repair the electrical system).
2. The actuator is faulty (repair/adjust the actuator cams).

DUST AND DEBRIS COLLECTION SYSTEM

HOPPER, FILTER AND SUCTION HOSE CLEANING, AND GASKET CHECK

**WARNING!**

Protect body parts (eyes, hair, hands, etc.) properly, when performing cleaning procedures using compressed air or water gun.

Preliminary operations

1. Empty the hopper (3), drive the machine to a cleaning/washing appointed area, then engage the parking brake with the lever (66).
2. Lift and dump the hopper (3), according to the procedure shown in the User Manual.
3. Install the lid support rod (27).

Hopper cleaning

4. Clean the hopper (H) with pressurised water from a hydrocleaner (G).
5. Carefully check the suction sealing gasket (U) for integrity, and replace it if necessary.

Suction hose cleaning

6. Thoroughly clean the suction hose (R) inside, up to the suction inlet, with pressurised water.
7. Carefully check the suction sealing gasket (V) for integrity, and replace it if necessary.

Suction filter cleaning

8. Inside the hopper, remove the suction filter fastener (A).
9. Remove the suction filter (B).
10. Wash the deflector (C) and the fan (D) with pressurised water; check that all fan sectors (T) are clean.
11. Clean the suction filter (F) with pressurised water from a hydrocleaner (E).
12. Install the suction filter (B) and secure it with the fastener (A).
13. Remove the lid support rod (27) and lower the hopper (3) according to the procedure shown in the User Manual.
14. Turn the ignition key (76) to OFF position and remove it.

Breather filter cleaning

15. With a ladder and the help of an assistant, disengage the fasteners (I) of the breather filter hood (J).
16. Open the hood (K) and install the safety pin (L).
17. Remove the mounting screws (M), then remove the breather filter (N).
18. Clean the breather filter (P) with pressurised water from a hydrocleaner (O).
19. Install the breather filter and its hood performing steps from 15 to 17 in reverse order.

DUST AND DEBRIS COLLECTION SYSTEM

HOPPER, FILTER AND SUCTION HOSE CLEANING, AND GASKET CHECK (Continues)

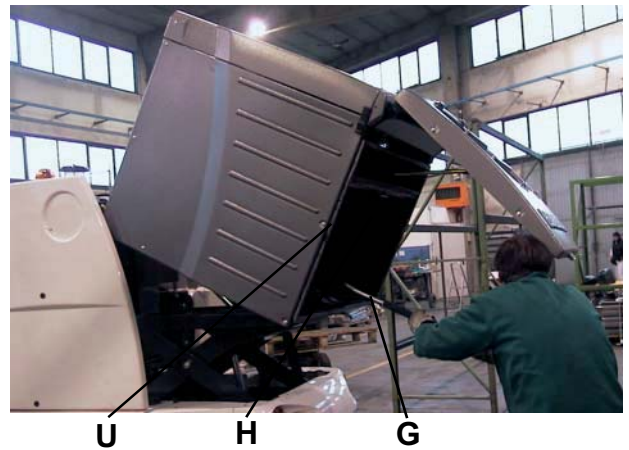
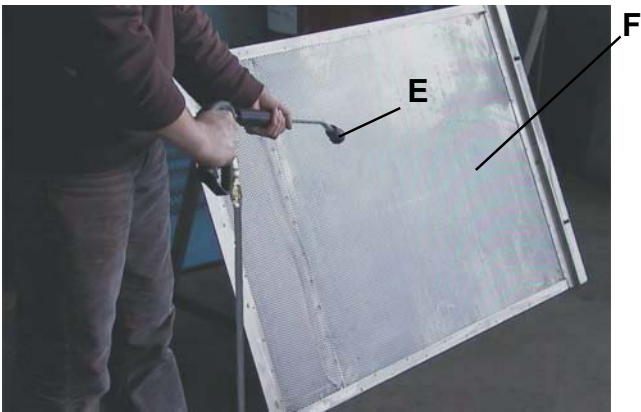
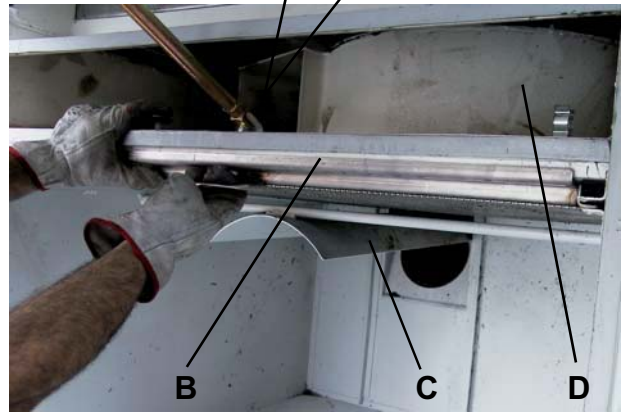
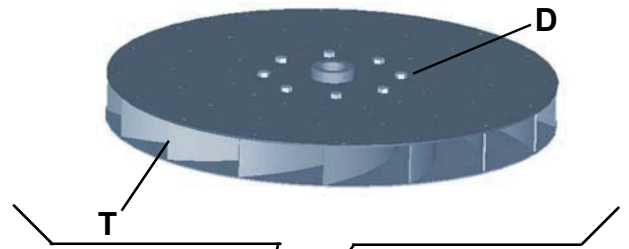

S300862

DUST AND DEBRIS COLLECTION SYSTEM

HOPPER, FILTER AND SUCTION HOSE CLEANING, AND GASKET CHECK (Continues)

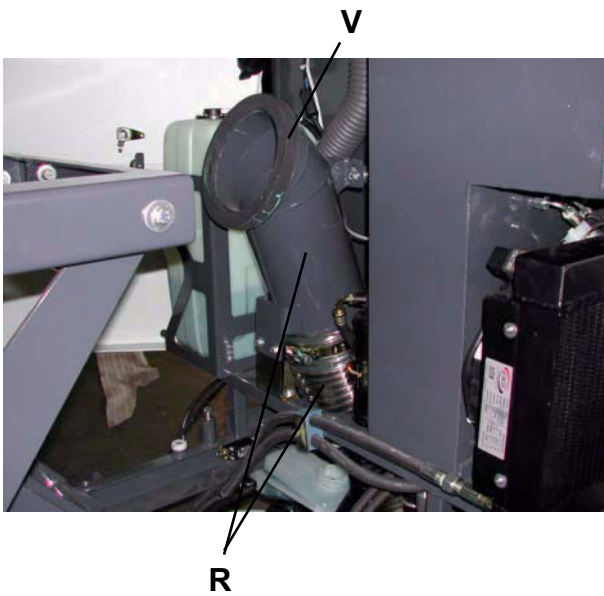
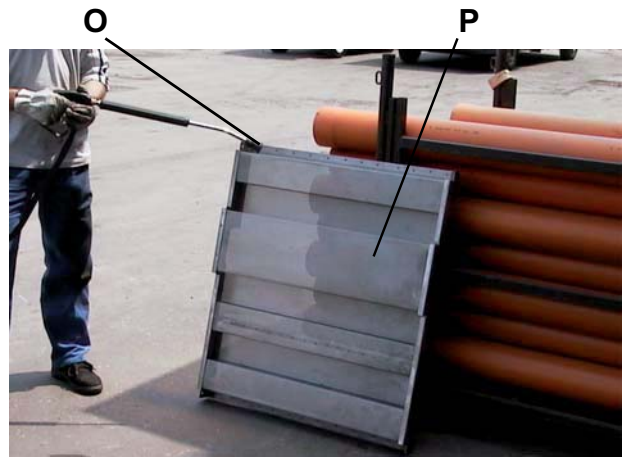
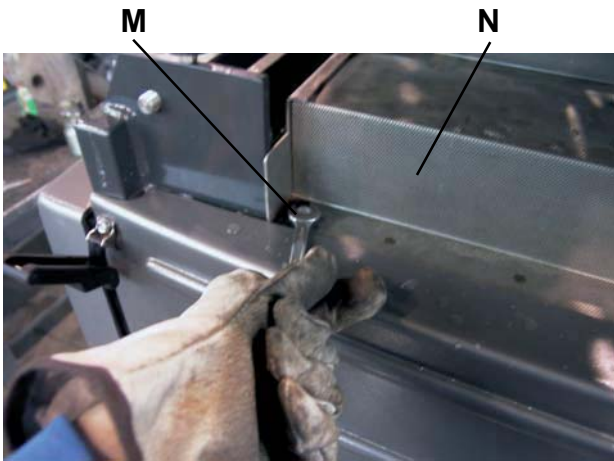

S300863

DUST AND DEBRIS COLLECTION SYSTEM**SUCTION INLET AND SKIRT HEIGHT AND OPERATION CHECK****Preliminary operations**

1. Engage the parking brake with the lever (66).
2. Lift the suction inlet (12), according to the procedure shown in the User Manual.
3. Turn the ignition key (76) to OFF position and remove it.

Suction inlet wheel check

4. Check that the three wheels (A) of the suction inlet are in good conditions and turn freely (they must not be bent/misshapen because of bumps or excessive pressure, etc.). Check also that the rubber thickness (B) is not lower than some millimeters. If necessary replace the wheels (A) (see the procedure in relevant paragraph).

Sliding panel check

5. Check that the main sliding panel (C) and the front (D) and (E) and rear (H) sliding panels are in good conditions and that their thickness (F) is not lower than 5 mm, otherwise replace them (see the procedure in the relevant paragraph). It is important to replace the sliding panels (C), (D), (E), and (H) when they are not completely worn, to avoid damaging the relevant mounting screws and making them difficult to remove. Replace the sliding panels (C), (D), (E), and (H) as a unit, to avoid steps in the union areas (G), caused by different levels of wear.

Suction inlet skirt and wheel adjustment check

6. Check that the skirt (I) is integral and that it does not have excessive tears (J) or lacerations (K), which can affect the suction inlet operation.
If necessary replace the skirt (I) (see the procedure in the relevant paragraph).
7. Drive the machine on a level ground and lower the suction inlet (12) according to the procedure shown in the User manual.
8. Turn the ignition key (76) to OFF position and remove it.
9. Check that the distance (L) of the skirt from the ground is not bigger than 1 cm. Greater distances can affect the suction inlet operation.
If necessary replace the skirt (K) (see the procedure in the relevant paragraph).
10. Also check that, when the three wheels (A) contact the ground, the sliding panels (C), (D), (E), and (H) do not touch the ground, otherwise the wheels (A) must be replaced to avoid an excessive wear of the sliding panels (for wheel replacement procedure, see the relevant paragraph).
11. Start the machine according to the procedure shown in the User Manual, then press the switch (69) and check that the skirt (I) lifts freely. Check that it lifts also when a force of some kg is applied (simulating to move bottles or other heavy objects that must then be collected). If necessary, adjust the opening force of the skirt (I) according to the following procedure:
 - Turn off the machine.
 - Remove the screws and the right panel (22) in the cab.
 - Loosen the control valve locknut (N) and turn the screw (O) as necessary, reminding that:
 - The opening force decreases by loosening the screw;
 - The opening force increases by tightening the screw.
 - When the adjustment is completed, tighten the locknut (N).
 - Install the right panel (22) in the cab and tighten the screws.

Reset

12. Assemble the components in the reverse order of disassembly.

DUST AND DEBRIS COLLECTION SYSTEM

SUCTION INLET AND SKIRT HEIGHT AND OPERATION CHECK (Continues)

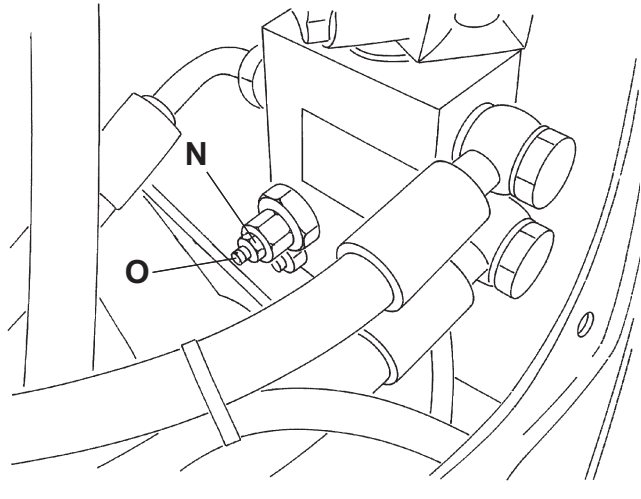
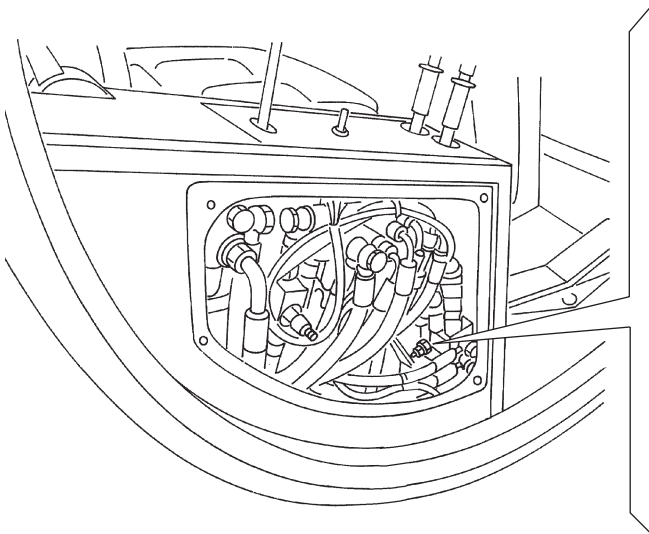
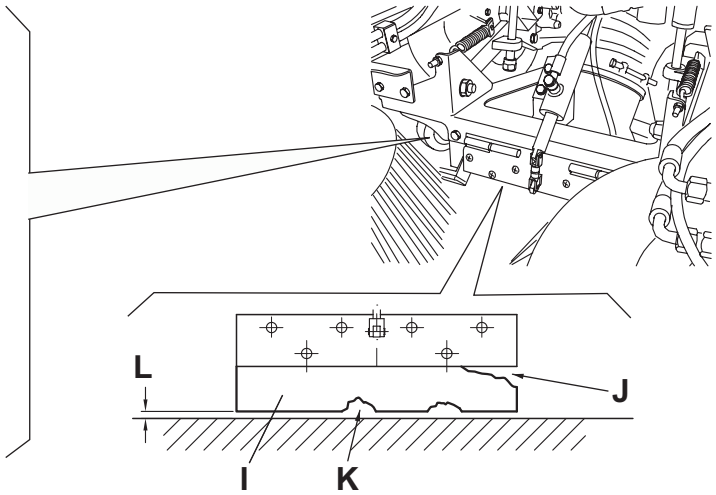
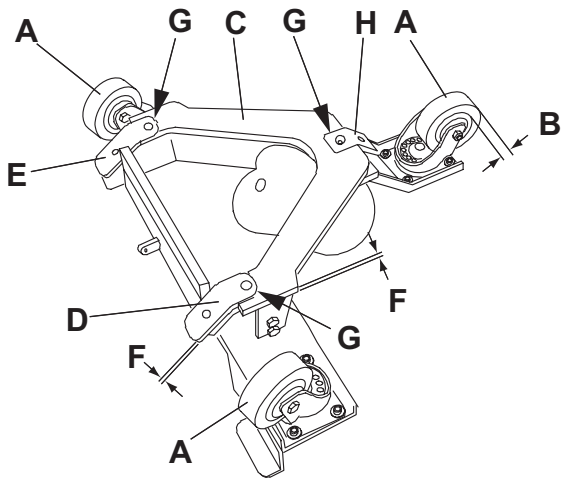

S301484

DUST AND DEBRIS COLLECTION SYSTEM**SUCTION INLET WHEEL DISASSEMBLY/ASSEMBLY****NOTE**

To remove the rear wheel (C), the machine must be lifted with an appropriate hoisting system. Otherwise, remove the suction inlet assembly (D) according to the procedure shown in the relevant paragraph. See the following disassembling procedures.

Front wheels (A) and (B) removal/installation

1. Engage the parking brake with the lever (66).
2. Lift the suction inlet (12), according to the procedure shown in the User Manual.
3. Turn the ignition key (76) to OFF position and remove it.
4. On both sides of the machine, loosen the screws (E) and (F), then remove the front wheels (A) and (B).
5. Install the new front wheels (A) and (B) and fasten them with the screws (E) and (F).
6. If necessary, perform the suction inlet and skirt height and operation check (see the procedure in the relevant paragraph).

Front wheels (A) and (B), and rear wheel (C) removal/installation

7. Place the machine on the appropriate hoisting system (if present) and lift it.
If the hoisting system is not available, remove the suction inlet assembly (D) (see the procedure in the relevant paragraph).
8. Remove the screws (E), (F) and (G), then remove the wheels (A), (B) and (C).
9. Install the new wheels (A), (B) and (C) and fasten them with the screws (E), (F) and (G).
10. Perform step 1 again.
11. If necessary, perform the suction inlet and skirt height and operation check (see the procedure in the relevant paragraph).

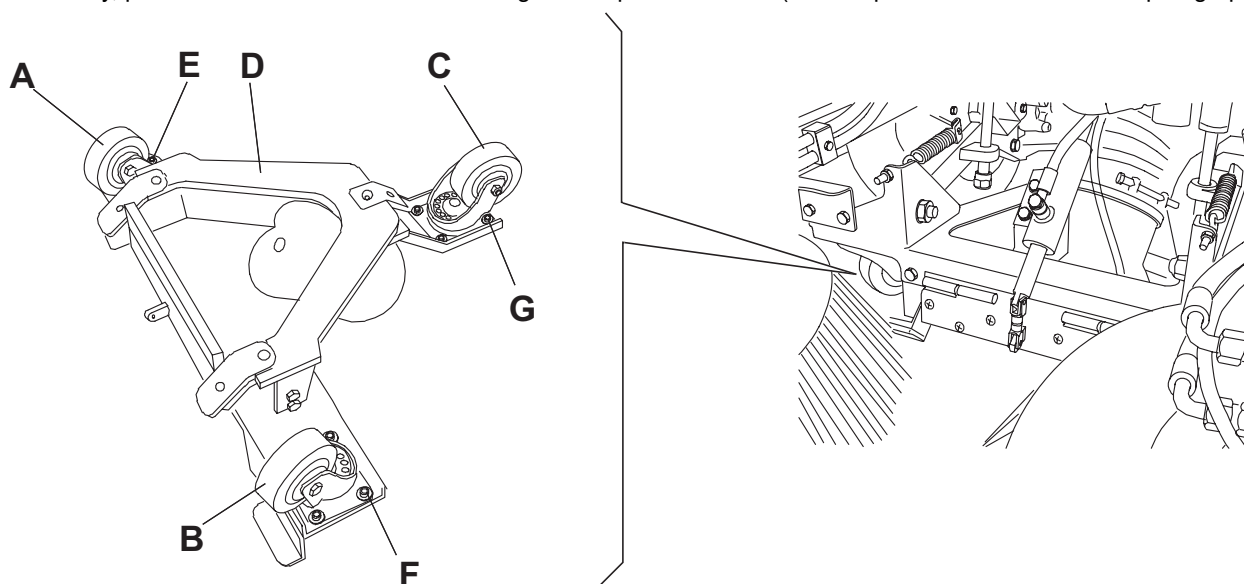

S301485

DUST AND DEBRIS COLLECTION SYSTEM

SUCTION INLET SLIDING PANELS DISASSEMBLY/ASSEMBLY



NOTE

To remove the suction inlet sliding panels, the machine must be lifted with an appropriate hoisting system. Otherwise, remove the suction inlet assembly (D) according to the procedure shown in the relevant paragraph. See the following disassembling procedures.

1. Place the machine on the appropriate hoisting system (if present) and lift it.
If the hoisting system is not available, remove the suction inlet assembly (D) (see the procedure in the relevant paragraph).
2. Remove the mounting screws (A), and (B), then remove the sliding panels (C), (D), and (E).
3. Install the new sliding panels (C), (D), and (E) and fasten them with the screws (A), and (B).
4. Also check that, when the wheels (F) contact the ground, the sliding panels (C), (D), and (E) do not touch the ground, otherwise the wheels (F) must be replaced to avoid an excessive wear of the sliding panels (for wheel replacement procedure, see the relevant paragraph).
5. Perform step 1 again.
6. If necessary, perform the suction inlet and skirt height and operation check (see the procedure in the relevant paragraph).

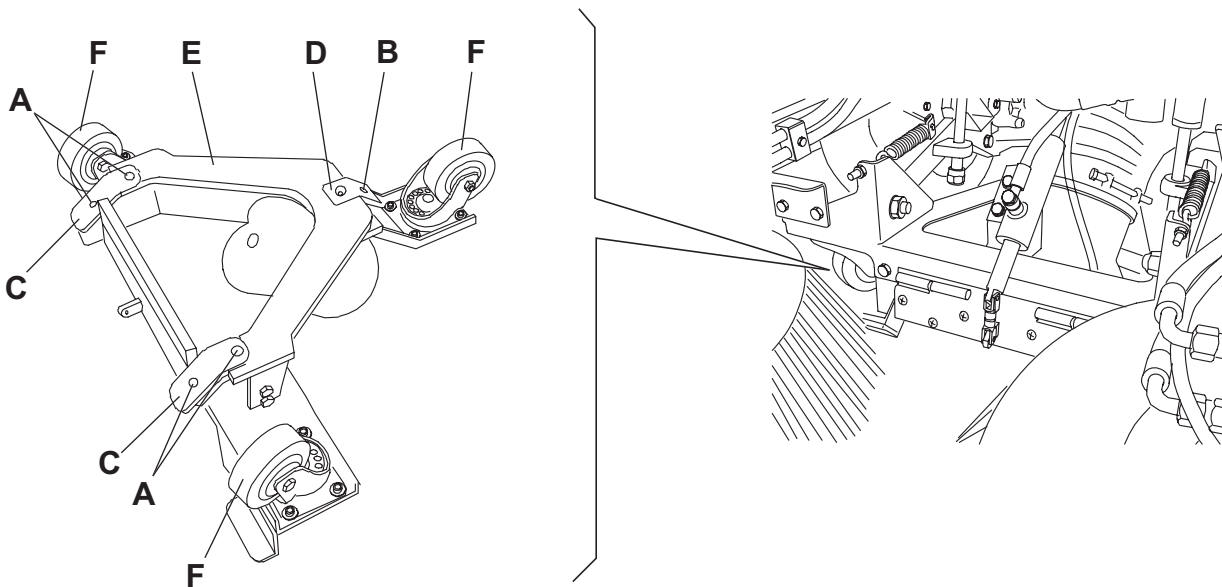

S301486

DUST AND DEBRIS COLLECTION SYSTEM**SUCTION INLET DISASSEMBLY/ASSEMBLY****Disassembly**

1. Remove the side brooms (see the procedure in the relevant paragraph).
2. Lower the suction inlet (12), according to the procedure shown in the User Manual.
3. Engage the parking brake with the lever (66).
4. Turn the ignition key (76) to OFF position and remove it.
5. Disconnect the hydraulic system hoses (A) and (B) from the suction inlet (C) and plug them.
6. Disconnect the dust control system water hose (D).
7. Remove the nuts (E) and pins (F).
8. Move the suction inlet (C) forward, and loosen the suction hose clamp (G).
9. Disconnect the suction hose (H) from the suction inlet.
10. Remove the suction inlet (C).

Assembly

11. Assemble the components in the reverse order of disassembly.
If necessary, perform the suction inlet and skirt height and operation check (see the procedure in the relevant paragraph).

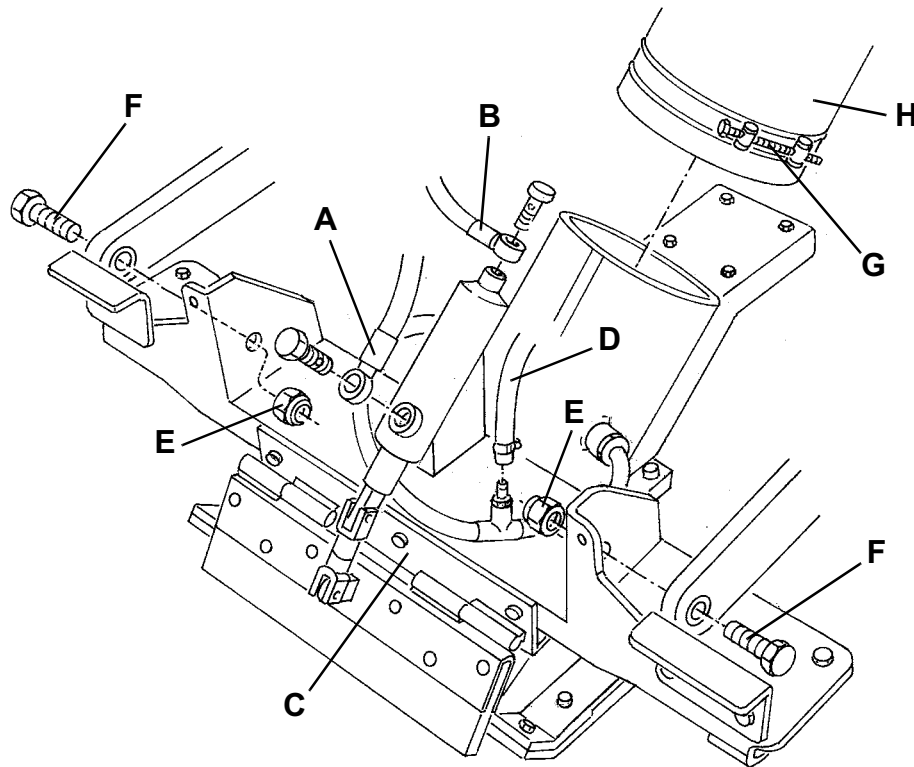

S301487

DUST AND DEBRIS COLLECTION SYSTEM

SKIRT REPLACEMENT

1. Lower the suction inlet (12), according to the procedure shown in the User Manual.
2. Engage the parking brake with the lever (66).
3. Turn the ignition key (76) to OFF position and remove it.
4. Remove the clip (A) and the skirt (B).
5. Remove the screws (C), then remove the skirt (D).
6. Install the new skirt (D) and fasten it with the screws (C).
7. Install the skirt (B) and the clip (A).
8. Lift the suction inlet (12), according to the procedure shown in the User Manual.

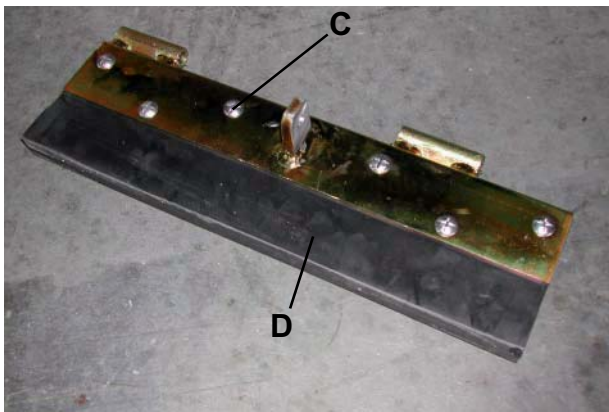

S300868

DUST AND DEBRIS COLLECTION SYSTEM**HOPPER POSITION ADJUSTMENT**

1. Empty the hopper (3); if it contains a small quantity of waste, it is not necessary to dump it.
2. Drive the machine on a solid and level ground, then engage the parking brake with the lever (66).
3. Open the right and left lids (20) and (18) by releasing the fasteners (21) and (19) with the supplied key.
4. Lift the hopper (3), according to the procedure shown in the User Manual.
5. Turn the ignition key (76) to OFF position and remove it.
6. Remove the locking pins (28) from the housings (29) and place them into the holes (30).
7. Loosen the locknuts (A).
8. Insert a lever into the holes (C), then turn the rods (B) as necessary.
9. Remove the locking pins (28) and place them into the holes (29).
10. Lower the hopper (3), according to the procedure shown in the User Manual, and check that the profiles (D) match the frame profiles (E).
11. If necessary, perform steps 4, 5, 6, 8, 9 and 10 again.
12. Then perform steps 3, 4, 5 and tighten the locknuts (A).
13. Lower the hopper (3), according to the procedure shown in the User Manual, and check that the hopper suction hole (F) match the suction hose gasket (G). If necessary, adjust the position of the suction hose (H) according to the procedure shown in the following steps.
14. Perform steps 4, 5 and 6 again.
15. Loosen the left and right side screws (I) (J) and (L), then adjust the position of the suction hose (H). Tighten the left and right side screws (I) (J) and (L).
16. Lower the hopper (3), according to the procedure shown in the User Manual, and check that the hopper suction hole (F) match the suction hose gasket (G).
17. Close the right and left lids (20) and (18) by engaging the fasteners (21) and (19) with the supplied key.

DUST AND DEBRIS COLLECTION SYSTEM

HOPPER POSITION ADJUSTMENT (Continues)

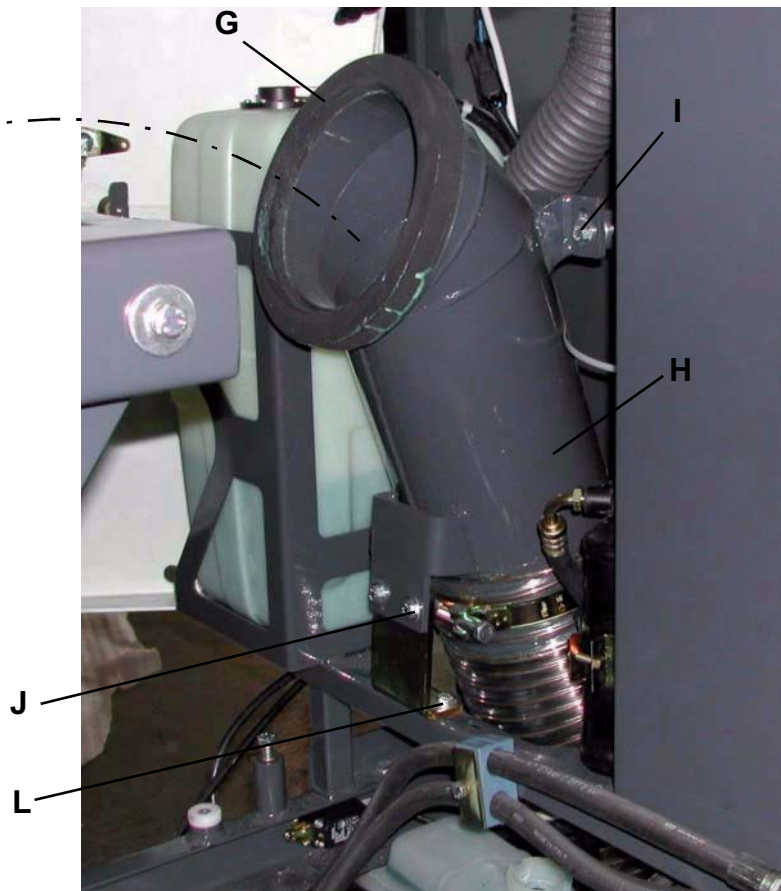
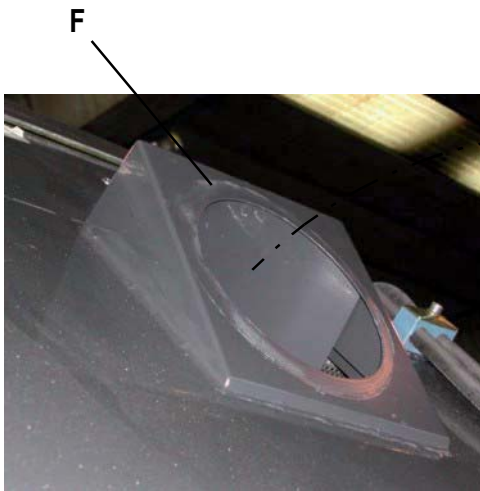
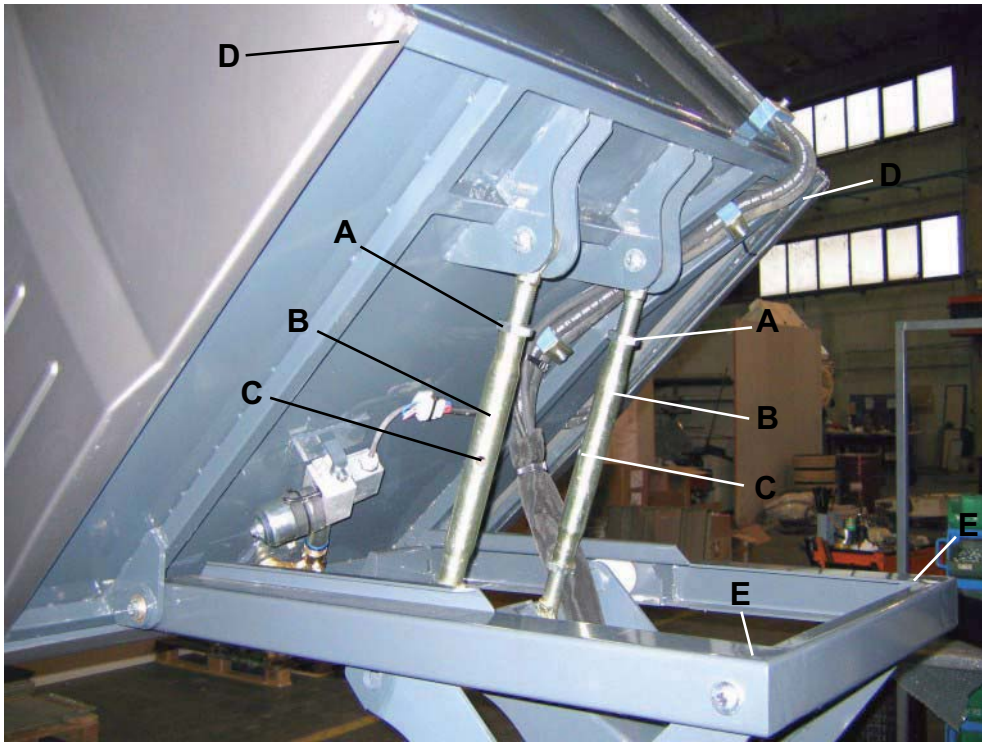

S300869

DUST AND DEBRIS COLLECTION SYSTEM

HOPPER LID CLOSING ACTUATOR ADJUSTMENT

Preliminary operations

1. Empty the hopper (3), according to the procedure shown in the User Manual.
2. Drive the machine on a solid and level ground, then engage the parking brake with the lever (66).
3. Lift the hopper (3), according to the procedure shown in the User Manual.
4. Turn the ignition key (76) to OFF position and remove it.
5. Open the right lid (20) by releasing the fasteners (21) with the supplied key.
6. Remove the locking pins (28) from the housings (29) and place them into the holes (30).
7. Remove the screws (A), then remove the cover (B) and the gasket (C) of the actuator (R), under the rear side of the hopper.

Lid safety hook closing

8. According to the procedure shown in the User Manual, turn the safety hook (D) of the lid (E) to closing position (as shown in the figure); in this condition, loosen the security dowel (F) of the cam (G), and then turn the cam until the microswitch (H) activates.

Open safety hook warning light adjustment

9. When the safety hook (D) of the lid (E) is turned to closing position (as shown in the figure), loosen the security dowel (I) of the cam (J), and turn the cam until the corner (K) causes the microswitch (L) to activate and the warning light to turn off.

Lid safety hook opening end-of-stroke adjustment

10. According to the procedure shown in the User Manual, turn the safety hook (D) of the lid (E) to the opening end-of-stroke; in this condition, loosen the security dowel of the cam (N), and then turn the cam until the microswitch (O) activates.

**NOTE**

To maximize cam adjustment consider the following:

- The cam turns in the direction shown by the arrow (P) when the hook (D) opens;
- The cam turns in the direction shown by the arrow (Q) when the hook (D) closes.

11. To check the cam proper adjustment, open and close the hook (D) several times.

Reset

12. Perform steps 3 to 7 in the reverse order.

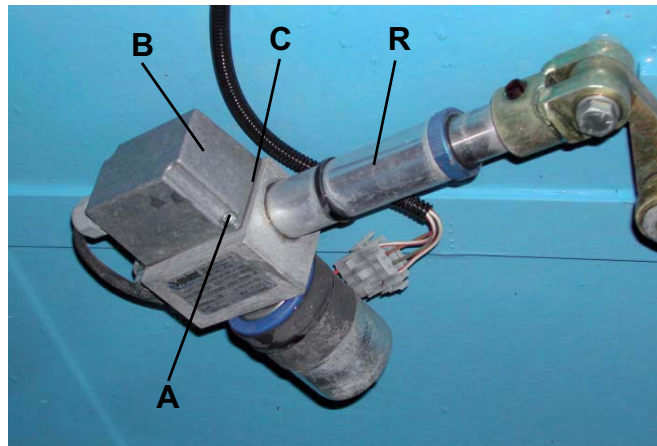

S300964

DUST AND DEBRIS COLLECTION SYSTEM

HOPPER LID CLOSING ACTUATOR ADJUSTMENT (Continues)

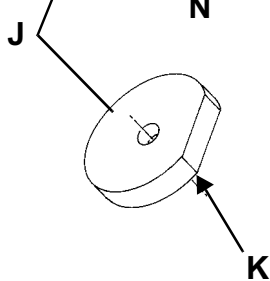
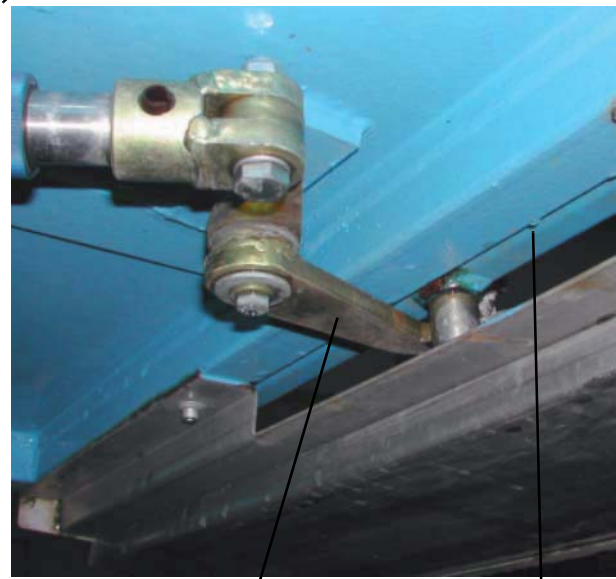
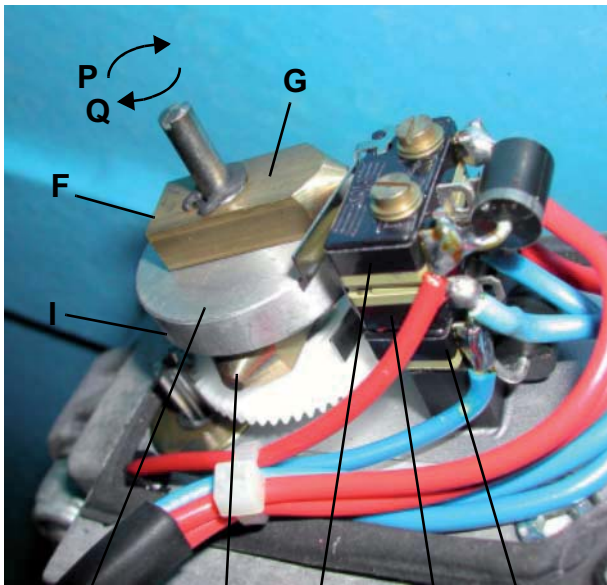
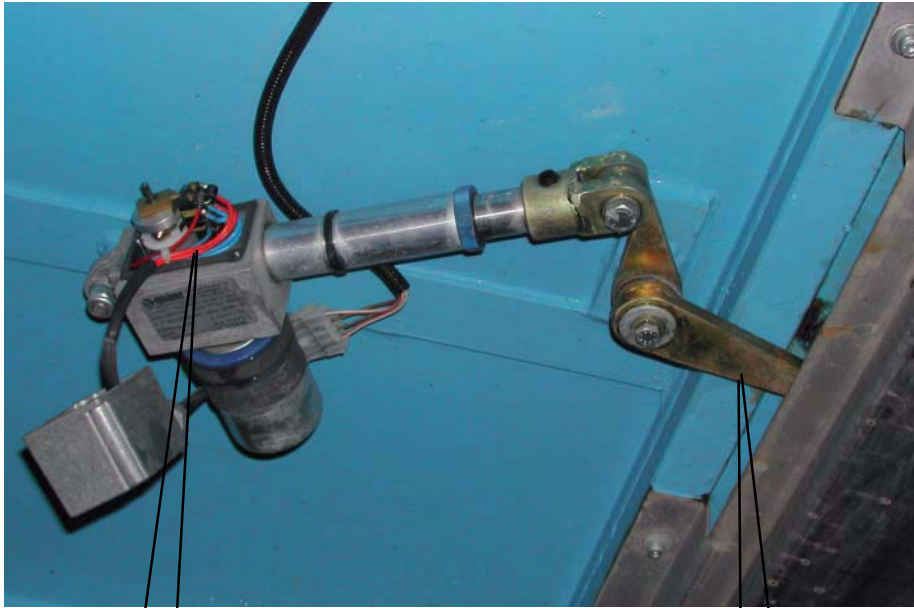

S300965

DUST AND DEBRIS COLLECTION SYSTEM**MOTOR AND SUCTION FAN DISASSEMBLY/ASSEMBLY****Disassembly**

1. Engage the parking brake with the lever (66).
2. Turn the ignition key (76) to OFF position and remove it.
3. With a ladder and the help of an assistant, disengage the fasteners (A) of the breather filter hood (B).
4. Open the hood (C) and install the safety pin (D).
5. Remove the mounting screws (E), then remove the breather filter (F).
6. Disconnect the hoses joints (G) and (H) from the suction fan motor (I).
7. Remove the mounting nuts (J) of the flange (M).
8. With an appropriate hoisting system, remove the suction fan motor assembly (K) by removing the silicone along the perimeter (L) of the flange (M), then sling the assembly (K) by placing a rope around the motor (I) and the fittings (N).
9. At the workbench, remove the screw (O) and the fan (P).
10. Remove the nuts (Q) from the screws (R).
11. Remove the motor (I) from the flange (M).

Assembly

12. Assemble the components in the reverse order of disassembly and note the following:
 - Remove the silicone along the perimeter (L) of the flange (M) and from the flange housing on the hopper.
 - Apply new silicone along the perimeter (L) of the flange (M).

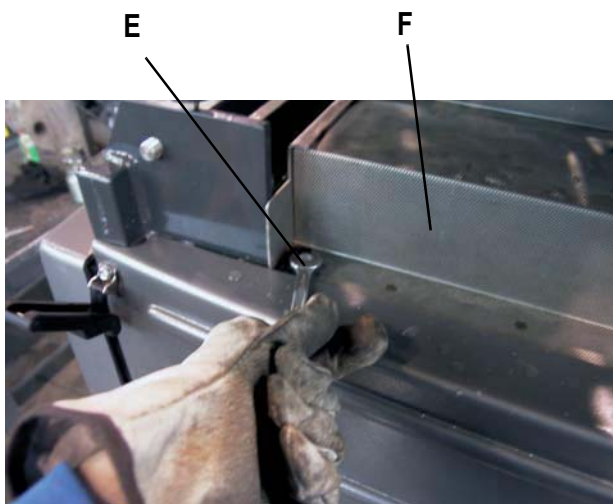
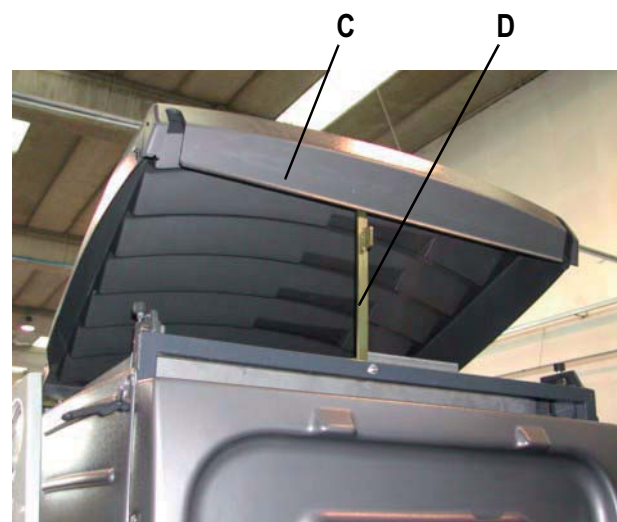
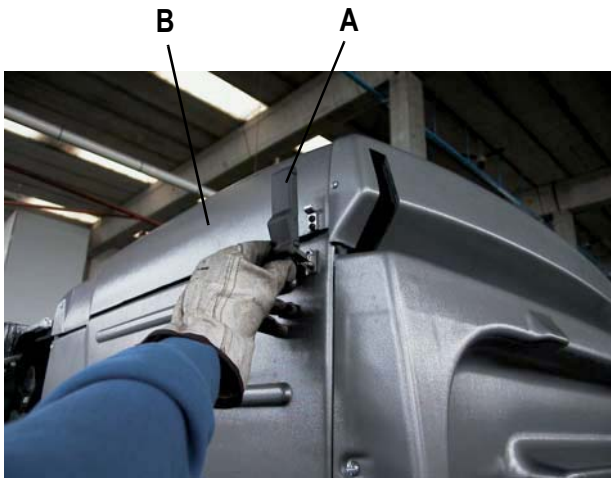

S300870

DUST AND DEBRIS COLLECTION SYSTEM

MOTOR AND SUCTION FAN DISASSEMBLY/ASSEMBLY (Continues)

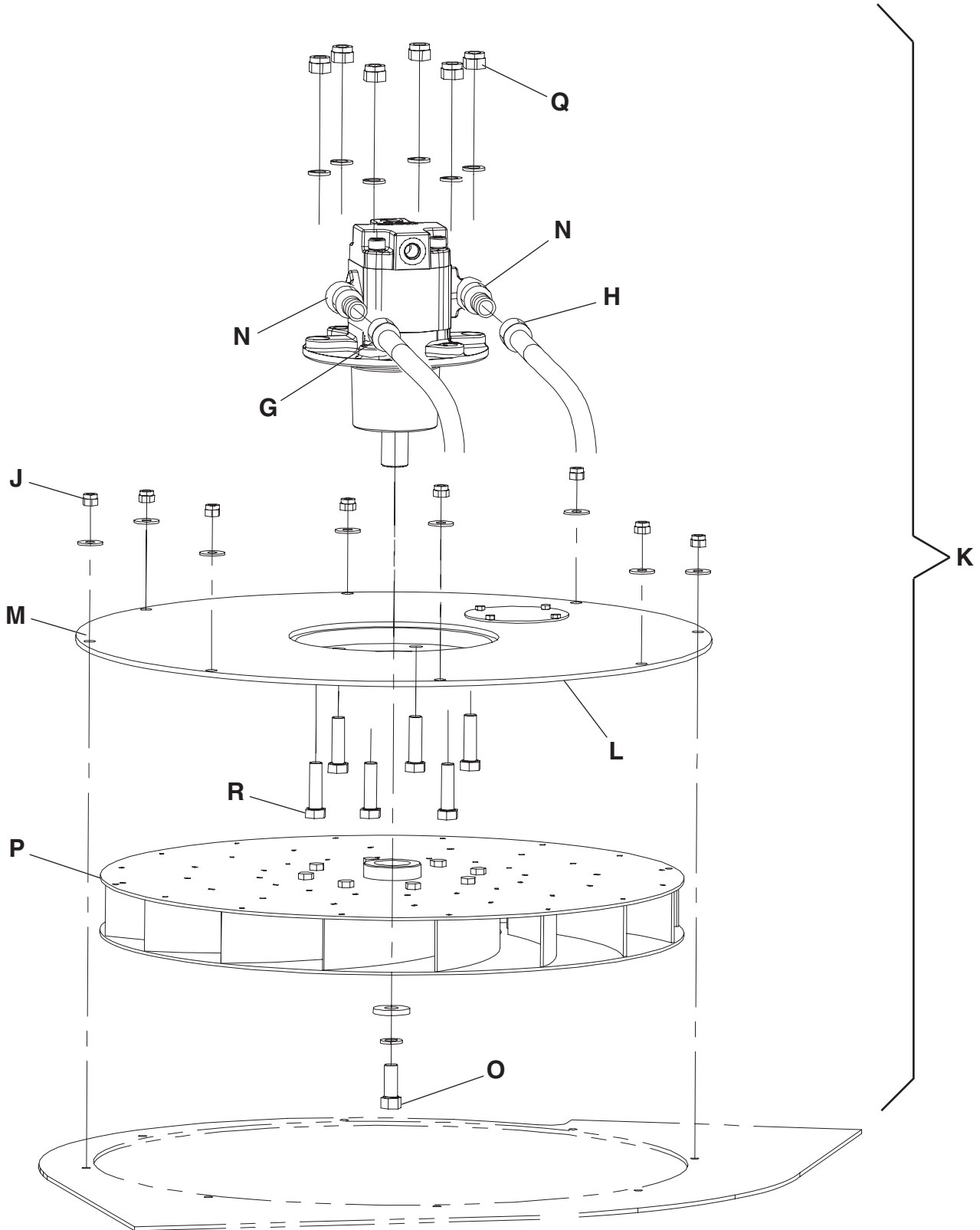

S301488

DUST AND DEBRIS COLLECTION SYSTEM**SUCTION HOSE DISASSEMBLY/ASSEMBLY****Preliminary operations**

1. Empty the hopper (3); if it contains a small quantity of waste, it is not necessary to dump it.
2. Drive the machine on a solid and level ground, then engage the parking brake with the lever (66).
3. Lift the hopper (3), according to the procedure shown in the User Manual.
4. Turn the ignition key (76) to OFF position and remove it.
5. Open the right and left lids (20) and (18) by releasing the fasteners (21) and (19) with the supplied key.
6. Remove the locking pins (28) from the housings (29) and place them into the holes (30).

Disassembly

7. Loosen the clamp (A) and disconnect the suction hose (B) from the suction inlet (C).
8. Loosen the left and right side mounting screws (D) of the suction hose upper end (E).
9. Remove the suction hose (F) by pulling it upwards.

Assembly

10. Assemble the components in the reverse order of disassembly and note the following:
 - For a easier installation of the suction hose (B) into the suction inlet (C), apply a thin coat of grease on the sliding parts.

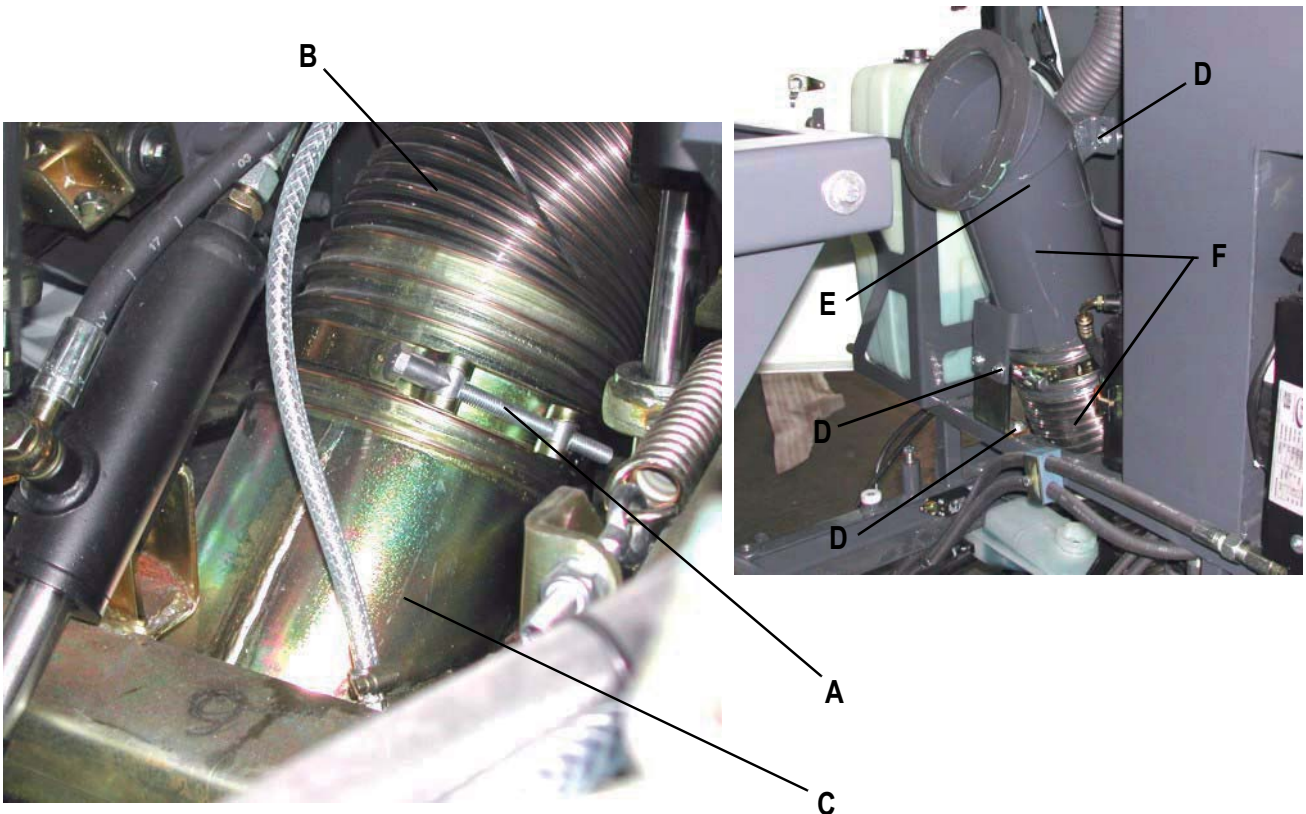

S300874

DUST AND DEBRIS COLLECTION SYSTEM

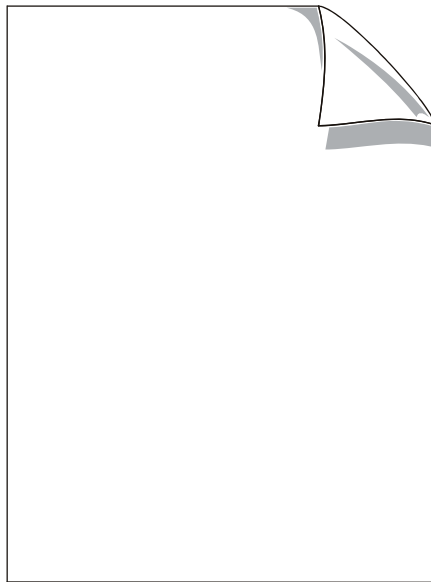

DUST CONTROL SYSTEM

DUST CONTROL SYSTEM

DESCRIPTION

The dust control system consists of:

- A) Right water tank
- B) Left water tank
- C) Tank filler plugs
- D) Broom nozzles
- E) Suction inlet nozzles
- F) Water filter
- G) Hose
- H) Water level indicator
- I) Nozzle pump
- J) Taps
- K) Rear suction pipe nozzle
- L) Opening tap
- M) Tank drain plugs

The water gun connected to the dust control system consists of:

- N) Water gun pump
- O) Quick coupling
- P) Water gun
- Q) Hose
- R) Reel
- S) Pressure gauge

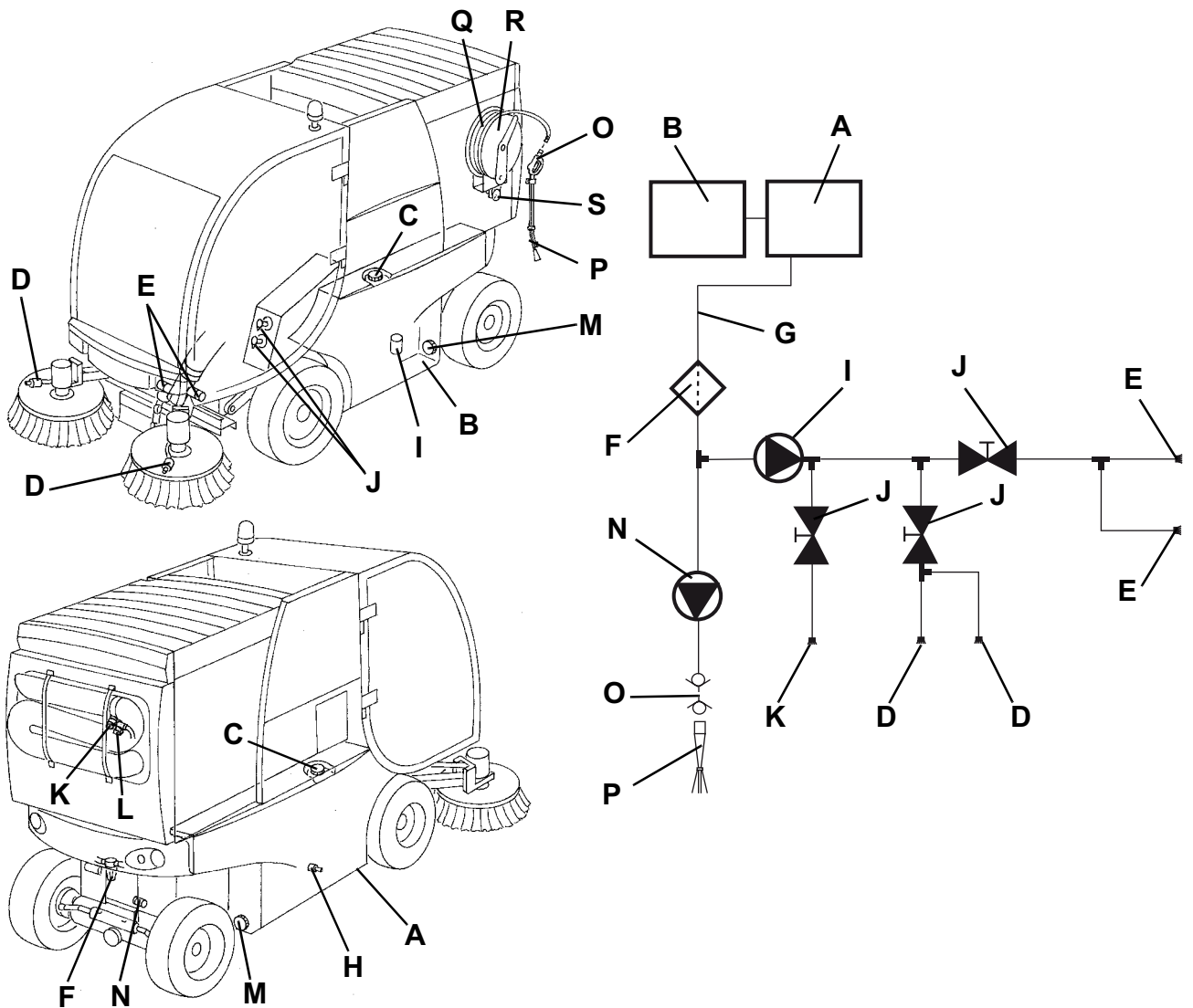

S301489

DUST CONTROL SYSTEM

TROUBLESHOOTING

No water from the nozzles

Possible causes:

1. The water filter is clogged (clean/replace).
2. The nozzles are clogged (clean).

No water to the nozzles

Possible causes:

1. The water pump relay is burned (replace).
2. The pump does not work (repair/replace).

DUST CONTROL SYSTEM**NOZZLE AND FILTER CLEANING****WARNING!**

Protect body parts (eyes, hair, hands, etc.) properly, when performing cleaning procedures using compressed air or water gun.

Preliminary operations

1. Engage the parking brake with the lever (66).
2. Turn the ignition key (76) to OFF position and remove it.

Cleaning of nozzles and filters on brooms

3. Unscrew the ring nuts (A).
4. Clean the nozzles (B) and filters (C) with compressed air. Remove calcium deposits. If necessary, replace the filters (C).
5. Install the filters and nozzles, and secure them with the ring nuts. Nozzle holes must be directed down when tightening.

Cleaning of nozzles inside the suction inlet

6. On both sides of the suction inlet (D), remove the screws (E) together with the nozzles (F).
7. Clean the nozzles (F) and screws (E) with compressed air. Remove calcium deposits.
8. Assemble the components in the reverse order of disassembly.

Cleaning of nozzle and filter in the rear suction pipe

9. Remove the screw (G), the nozzle (H) and the filter (I).
10. Clean the nozzle (H) and filter (I) with compressed air. Remove calcium deposits. If necessary, replace the filter (I).
11. Assemble the components in the reverse order of disassembly.

DUST CONTROL SYSTEM

NOZZLE AND FILTER CLEANING (Continues)

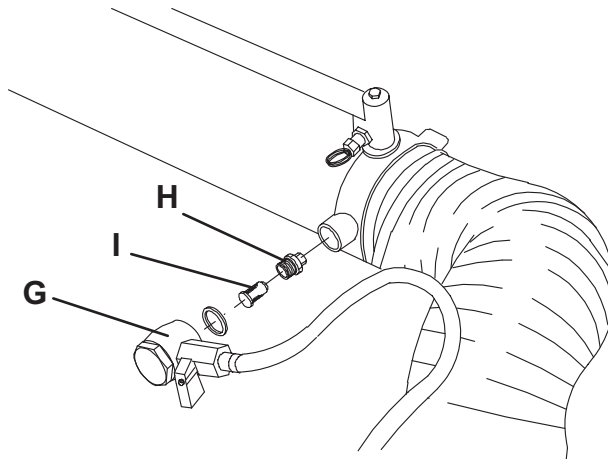
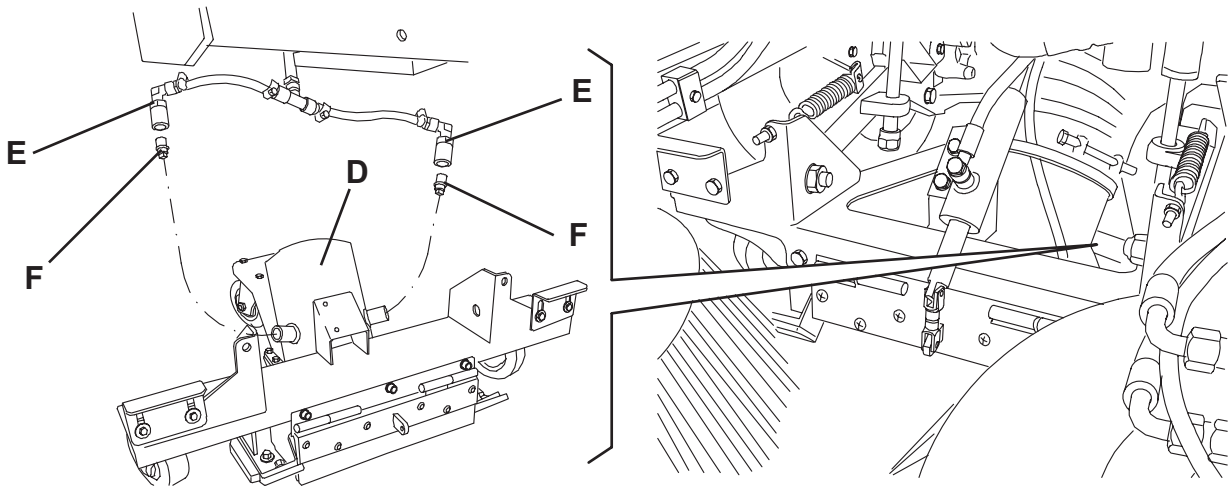
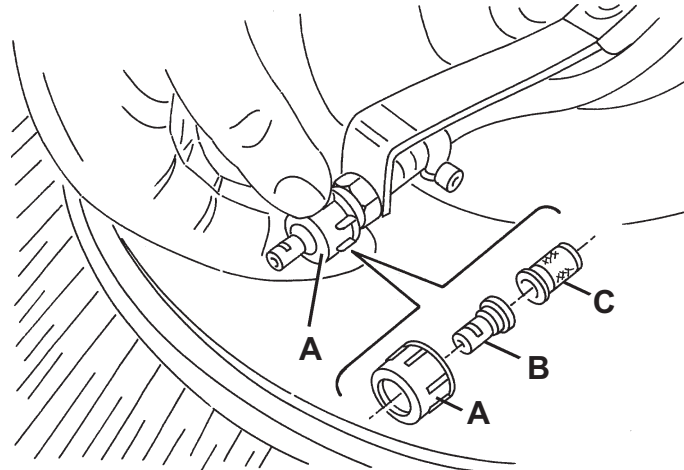

S301490

DUST CONTROL SYSTEM**WATER FILTER CLEANING****WARNING!**

Protect body parts (eyes, hair, hands, etc.) properly, when performing cleaning procedures using compressed air or water gun.

**NOTE**

When the filter is removed, the water inside the tanks comes out up to the filter level.

Preliminary operations

1. Turn the ignition key (76) to OFF position and remove it.
2. Engage the parking brake with the lever (66).
3. In the area over the rear axle (15), remove the water filter cover (A) together with the filter (B).
4. Separate the filter (B) from the cover (A), then wash and clean it. If necessary, replace the filter (B).
5. Install the filter (B) and the cover (A).
6. If necessary, fill the water tanks.

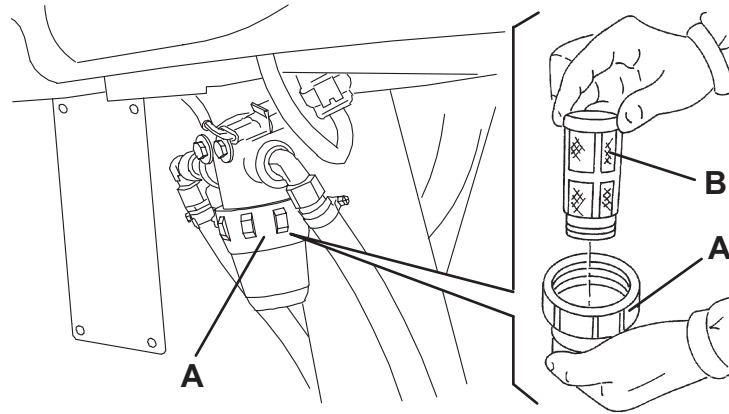

S301491

DUST CONTROL SYSTEM

WATER TANK EMPTYING

When necessary, empty the dust control system water tanks (7 and 16) according to the following procedure.

1. Turn the ignition key (76) to OFF position and remove it.
2. Engage the parking brake with the lever (66).
3. Remove the water tank drain plugs (A) and (B) and drain all the water from the tanks.
4. Install the plugs (A) and (B).

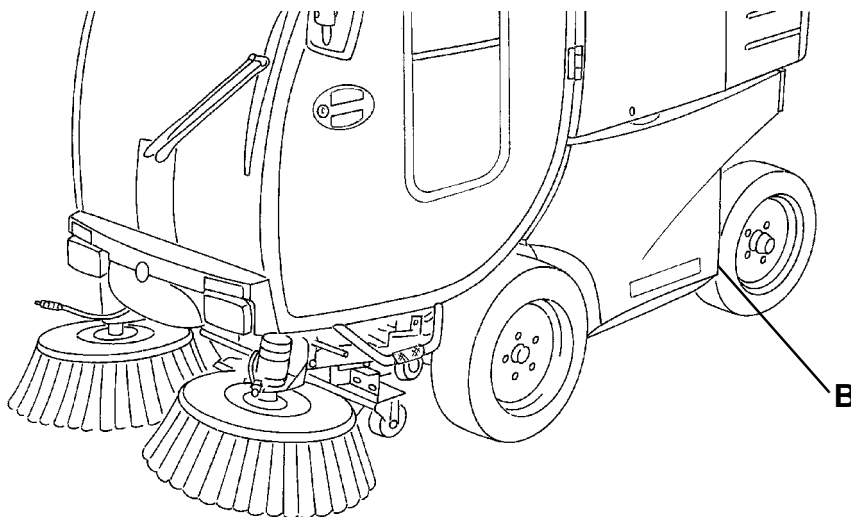
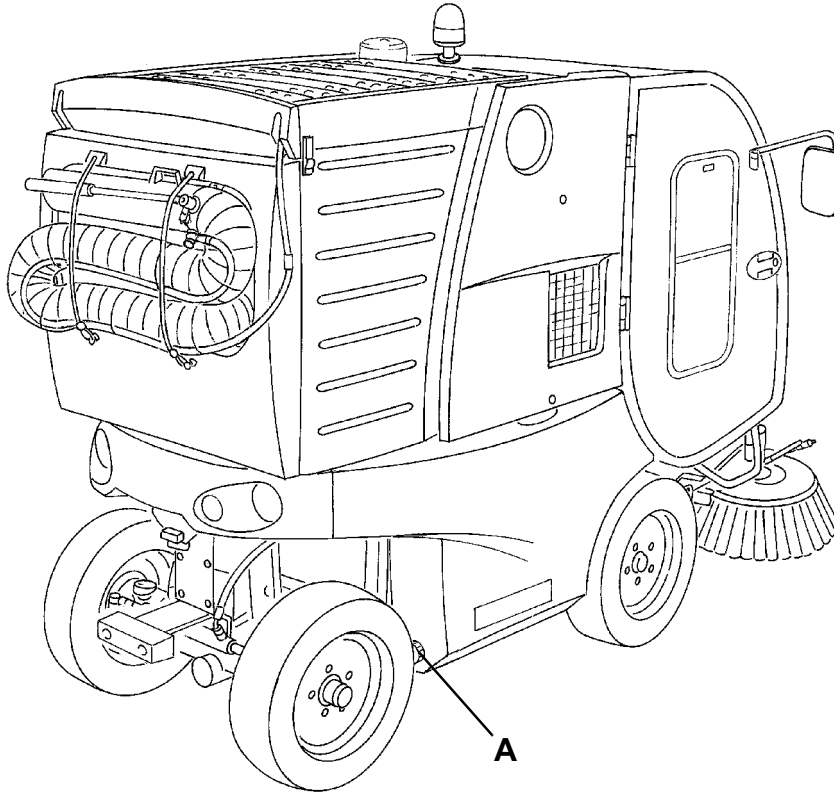

S301492

STEERING SYSTEM

DESCRIPTION

The steering wheel activates the steering gearbox, which controls an hydraulic cylinder that operates on the rear wheels assembled on a steering axle.

The steering system consists of:

- A) Oil pump
- B) Priority valve
- C) Steering gearbox
- D) Rear wheel control hydraulic cylinder
- E) Hydraulic system oil tank
- F) Hydraulic system hoses

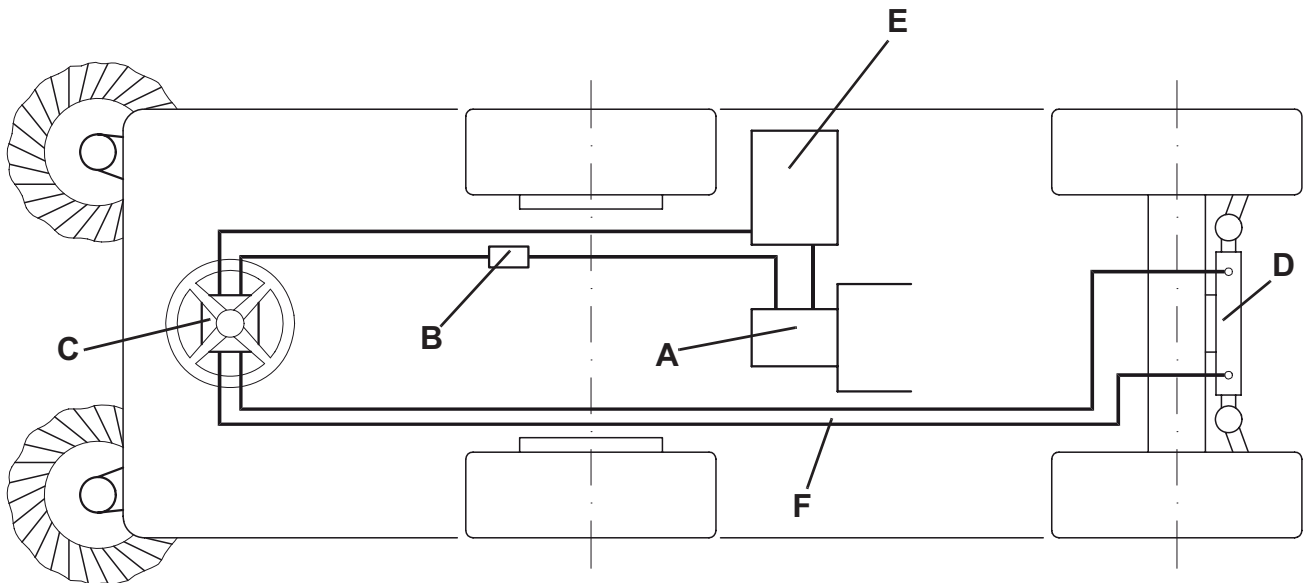

S300878

STEERING SYSTEM

TROUBLESHOOTING

The machine does not move straightforward

Possible causes:

1. The rear axle toe-in is incorrect (adjust).

The steering is hard

Possible causes:

1. The steering gearbox is faulty (replace).
2. The priority valve is faulty (replace).
3. The rear wheel control hydraulic cylinder is faulty (replace).

REAR AXLE TOE-IN ADJUSTMENT

1. Drive the machine on a solid and level ground and keep the rear wheels (A) in a straightforward position, then engage the parking brake with the lever (66).
2. Turn the ignition key (76) to OFF position and remove it.
3. Prepare two metal plates (B) to be used as reference lines. The plates must be a little longer than the wheel diameter.
4. Place the plates (B) on the external surface of the wheels (A), at the centre of the wheels and parallel to the ground, as shown in the figure.
Do not place the plates (B) where the tire surface is irregular.
5. Keeping the plates (B) in the above-mentioned position, check that the distances (E) and (F), measured on the front and on the back of the wheels (A), are the same. A maximum difference of 4 mm between the two distances is admitted. If necessary, adjust the distances by loosening the nuts (D) and turning the tie rods (C). Then tighten the nuts (D).

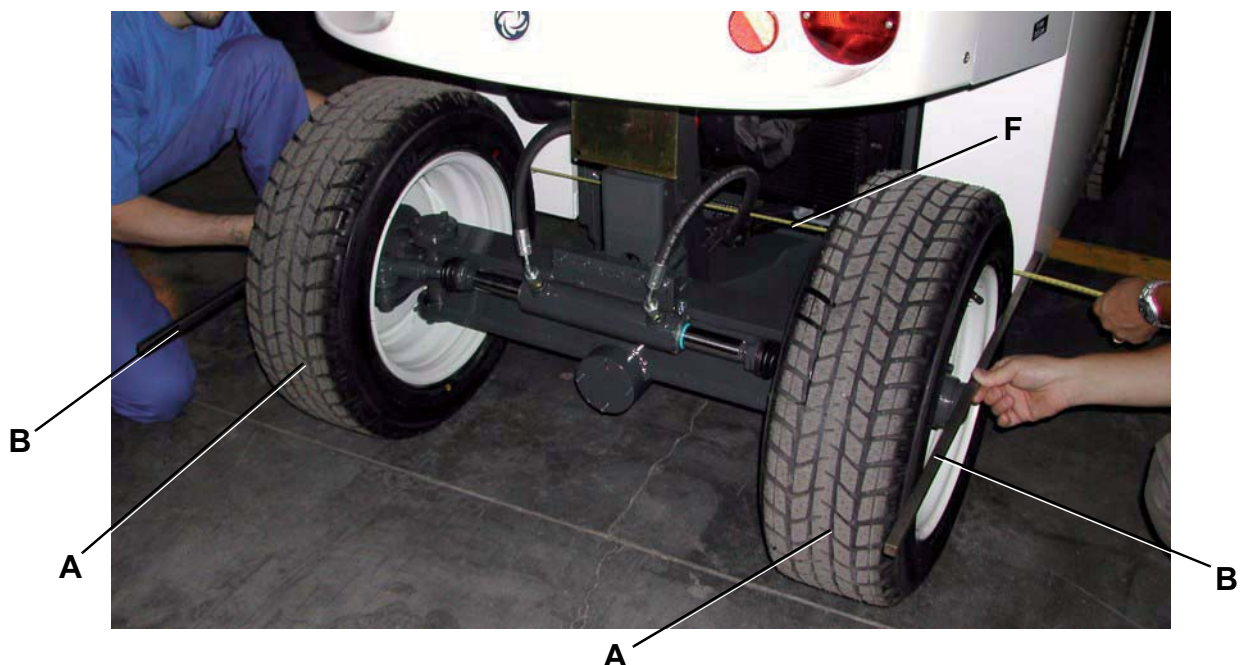
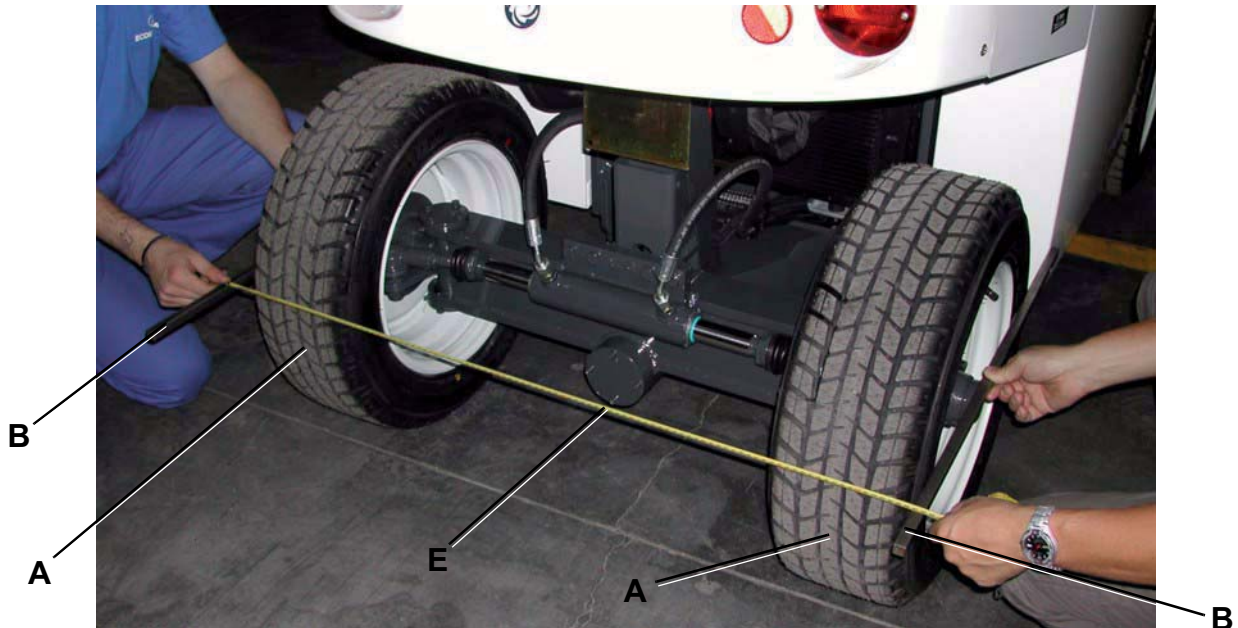

S300879

STEERING SYSTEM

REAR AXLE TOE-IN ADJUSTMENT (Continues)

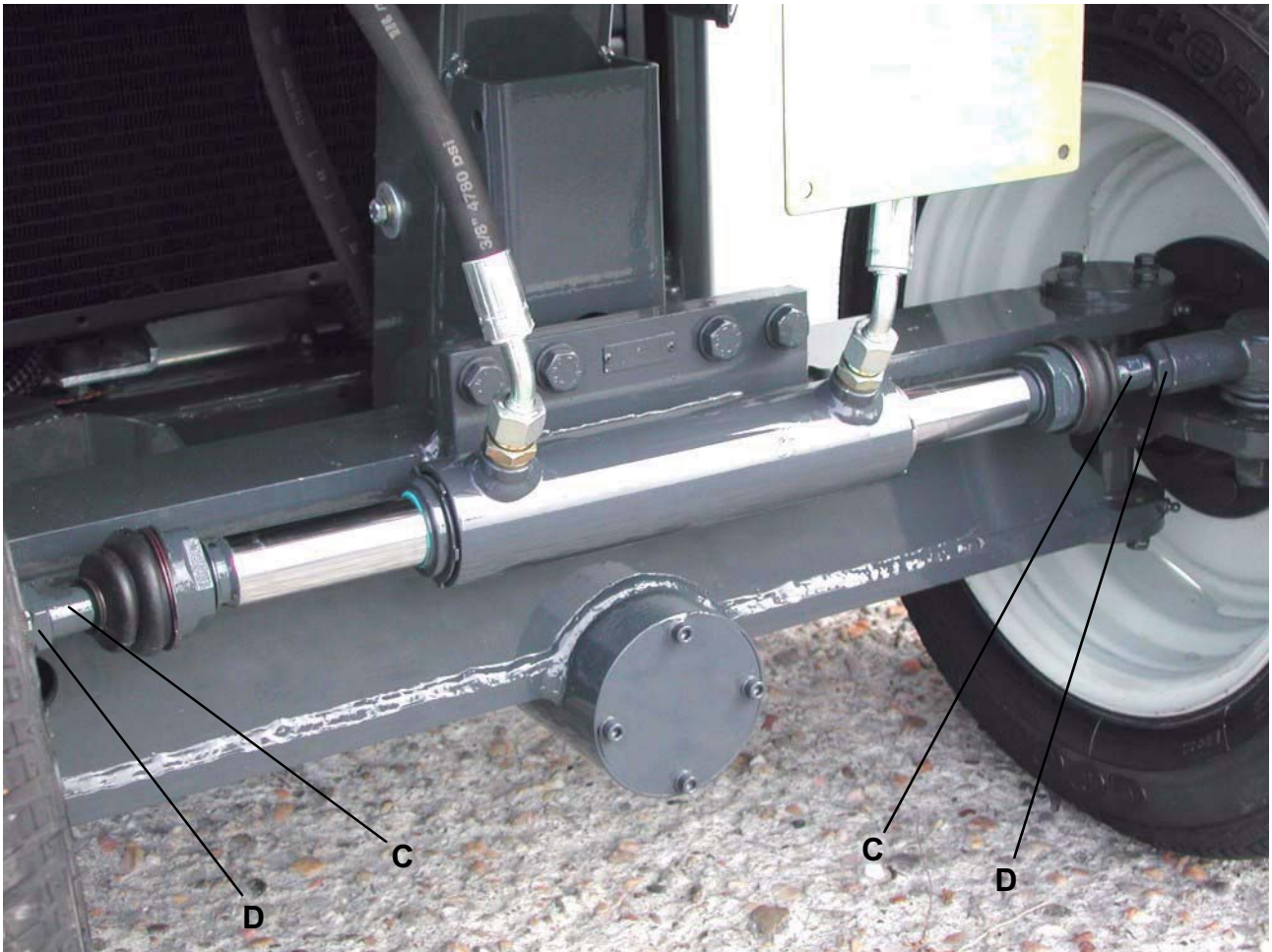

S300880

BRAKE SYSTEM

DESCRIPTION

The machine is equipped with an hydraulic brake system controlled by pedal, which actuates on the drum brakes of the front wheels.

The brake system consists of:

- A) Brake pedal
- B) Brake fluid pump
- C) Hydraulic system oil tank
- D) Cylinders
- E) Pipes
- F) Drum brakes

The parking brake is mechanic, manually controlled, and actuates on the drum brakes of the front wheels.

The parking brake consists of:

- G) Parking brake lever
- H) Bracket
- I) Control cable
- J) Drum brakes

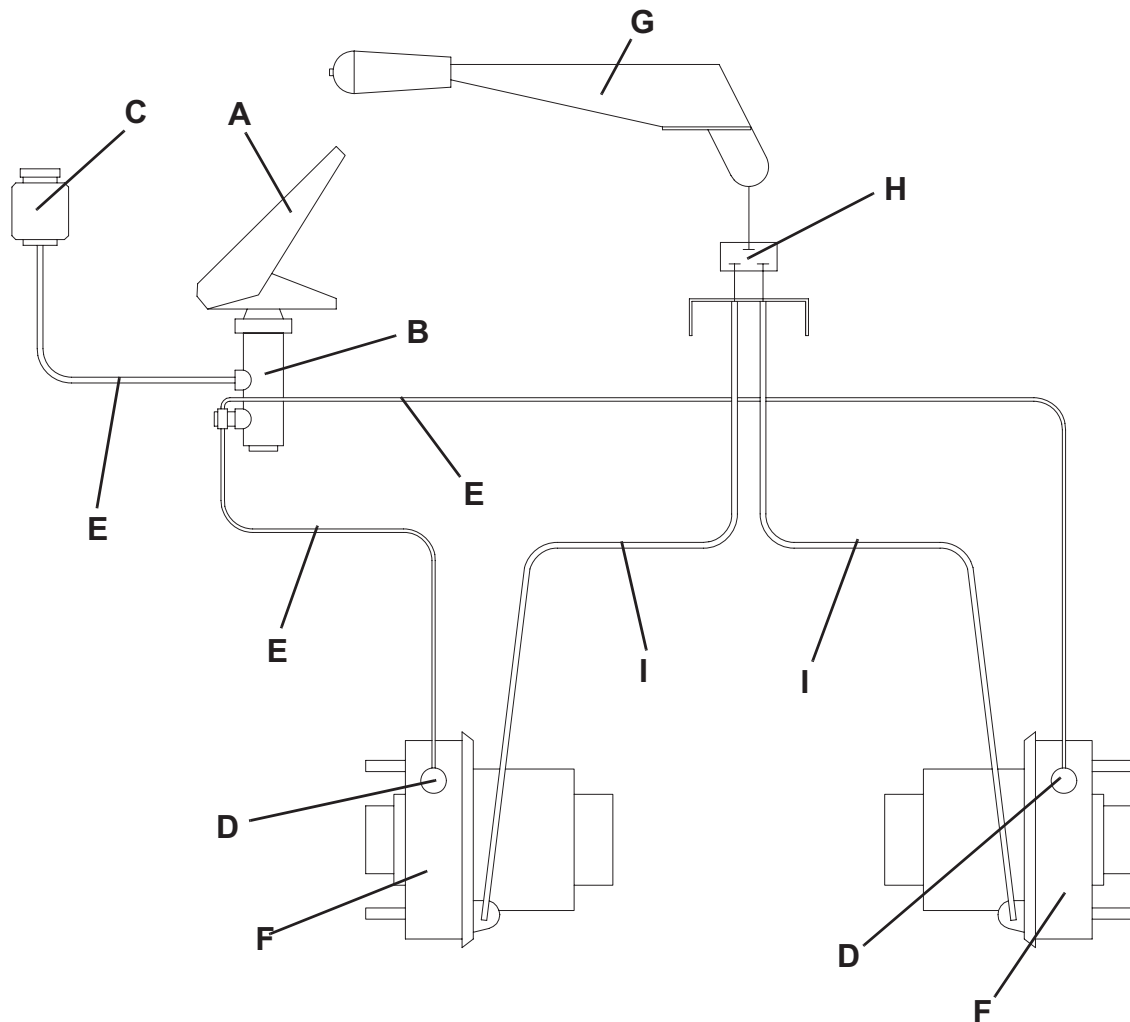

S300881

BRAKE SYSTEM

TROUBLESHOOTING

The machine brake system is not efficient

Possible causes:

1. The brake fluid is insufficient (check the fluid level).
2. The brake fluid pump is faulty (overhaul).
3. There is air in the system (bleed).
4. The drum brake cylinder is faulty (replace).
5. The braking masses are worn or greasy (replace).

The parking brake is not efficient

Possible causes:

1. The brake is misadjusted (adjust).

BRAKE FLUID LEVEL CHECK

1. Engage the parking brake with the lever (66).
2. Turn the ignition key (76) to OFF position and remove it.
3. Open the right lid (20).
Check that the fluid level in the tank (A) is approximately at 1 cm from the filler neck. If necessary, top up using the same type of fluid that is in the line. Type of fluid used: DOT4.
5. Close the right lid (20).

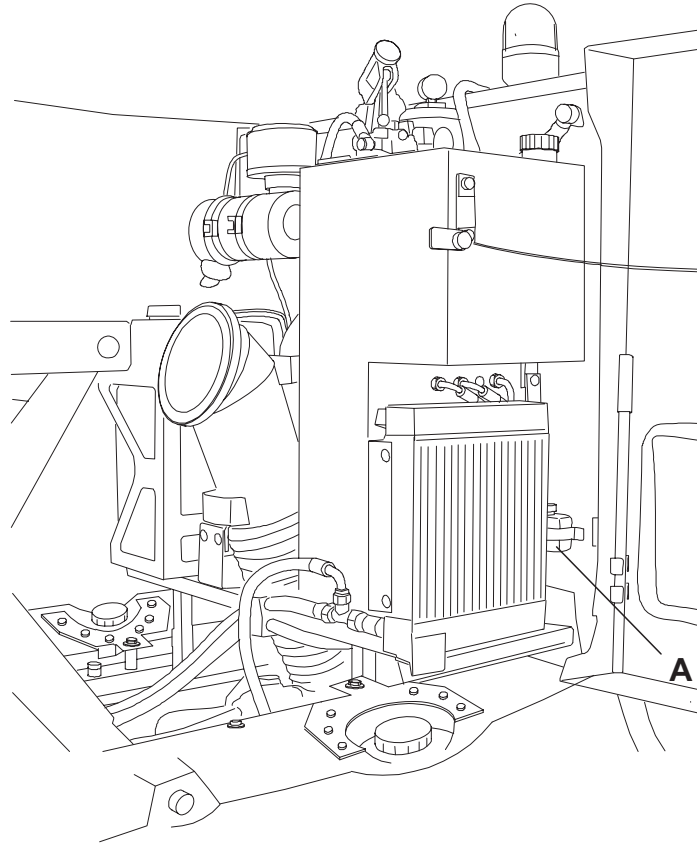

S301618

BRAKE SYSTEM

PARKING BRAKE CHECK AND ADJUSTMENT

Check

- Engage the parking brake lever (66) and check for proper operation. Check also that the brake operates in the same way on both the front wheels.
If necessary, adjust the parking brake according to the following procedure.

Adjustment

- Empty the hopper (3); if it contains a small quantity of waste, it is not necessary to dump it.
- Drive the machine on a solid and level ground, then engage the parking brake with the lever (66).
- Lift the hopper (3), according to the procedure shown in the User Manual.
- Turn the ignition key (76) to OFF position and remove it.
- Open the left lid (18) by releasing the fasteners (19) with the supplied key.
- Remove the locking pins (28) from the housings (29) and place them into the holes (30).
- Empty the dust control system water tanks (7 and 16) according to the procedure shown in the relevant paragraph.
- Remove the screw (42) and open the left tank (41).



WARNING!

Open the tanks (7 and 16) only if they are empty: each tank contains 120 kg of water approximately.

- Operating under the parking brake lever (66), adjust the brake control cables according to the following procedure depending on the type of adjustment (same adjustment for both wheels, or adjustment of one wheel only if braking is unbalanced):
 - To adjust both cables (I) in the same way: loosen the locknuts (D), move the bracket (B) as necessary along the tie rod (C), then tighten the locknuts (D); or loosen the locknuts (G) and (H), give the tie rods (E) and (F) the same number of turns, then tighten the locknuts (G) and (H).
 - To adjust just one of the cables (I): loosen the locknuts (G) or (H), turn the tie rods (E) or (F), then tighten the locknuts (G) or (H).
- Perform steps 4, 5, 6, 7 and 9 in the reverse order.
- If necessary, fill the dust control system water tanks according to the procedure shown in the User Manual.

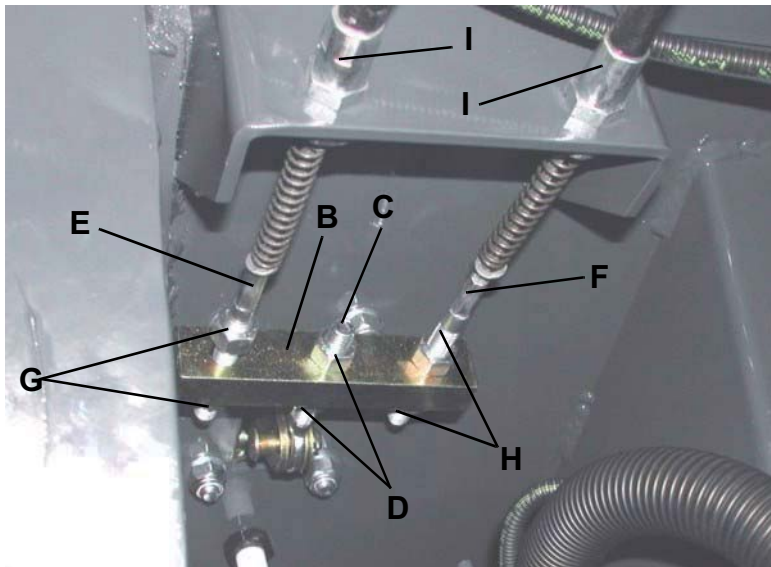

S300883

PARKING BRAKE CONTROL CABLE REPLACEMENT

1. Empty the hopper (3); if it contains a small quantity of waste, it is not necessary to dump it.
2. Drive the machine on a solid and level ground, then engage the parking brake with the lever (66).
3. Lift the hopper (3), according to the procedure shown in the User Manual.
4. Turn the ignition key (76) to OFF position and remove it.
5. Open the left lid (18) by releasing the fasteners (19) with the supplied key.
6. Remove the locking pins (28) from the housings (29) and place them into the holes (30).
7. Empty the dust control system water tanks (7 and 16) according to the procedure shown in the relevant paragraph.
8. Remove the screw (42) and open the left tank (41).

**WARNING!**

Open the tanks (7 and 16) only if they are empty: each tank contains 120 kg of water approximately.

9. Operating under the parking brake lever (66), unscrew the locknuts (C) and (D), disconnect the control cable (E) or (F) and recover the relevant spring (G).
10. Remove the front wheel (see the procedure in the relevant paragraph).
11. Place safety stands under the machine side sill.
12. Remove the screw (H) and the screws (I), then remove the washer (J).
13. Remove the drum (K).
14. Remove the three springs (L).
15. Remove the shoe retaining springs (M).
16. Remove the shoes (N) by disengaging the parking brake control cable (O) from the lever (P).
17. Perform steps 3 to 6 and 8 to 16 in the reverse order.
18. Adjust the parking brake (see the procedure in the relevant paragraph).
19. If necessary, fill the dust control system water tanks according to the procedure shown in the User Manual.

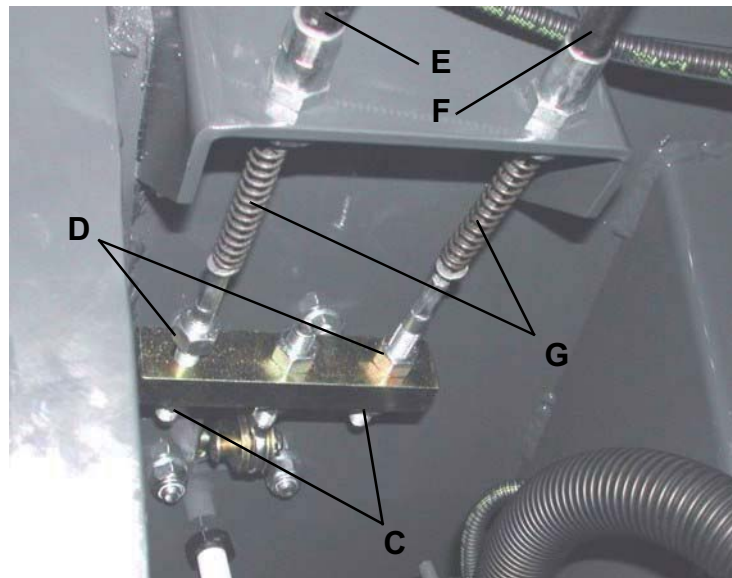

S300884

BRAKE SYSTEM

PARKING BRAKE CONTROL CABLE REPLACEMENT (Continues)

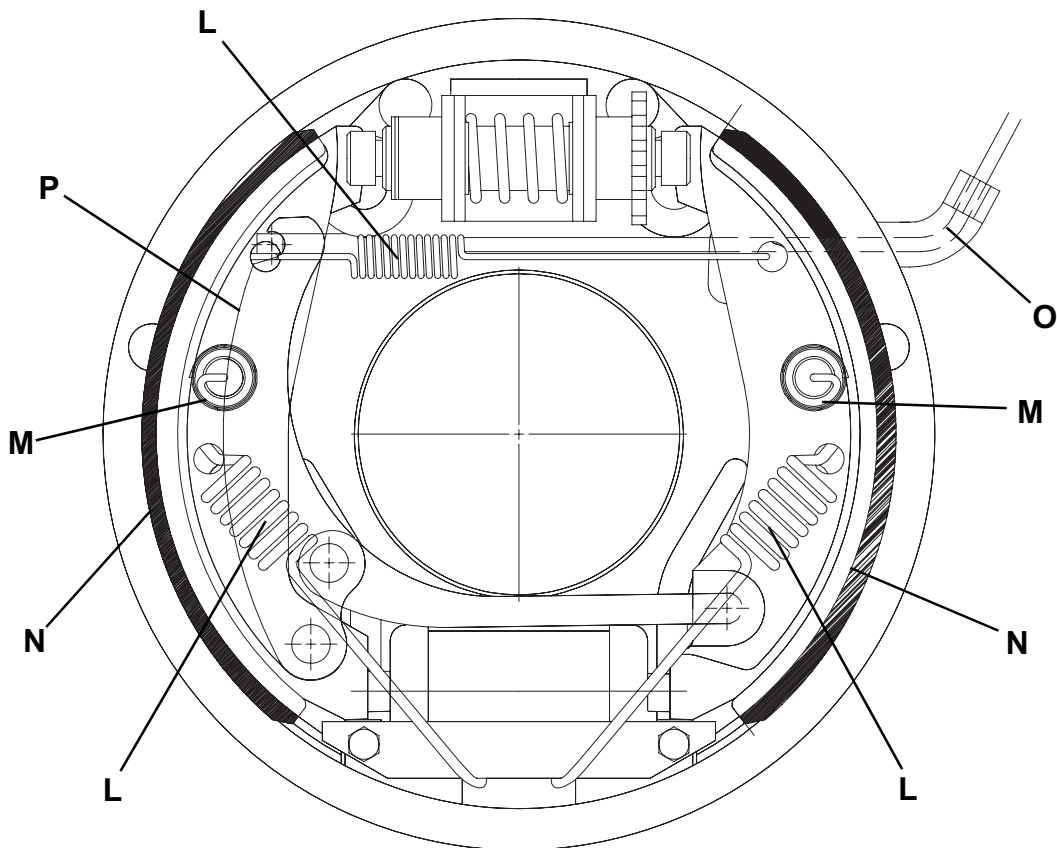
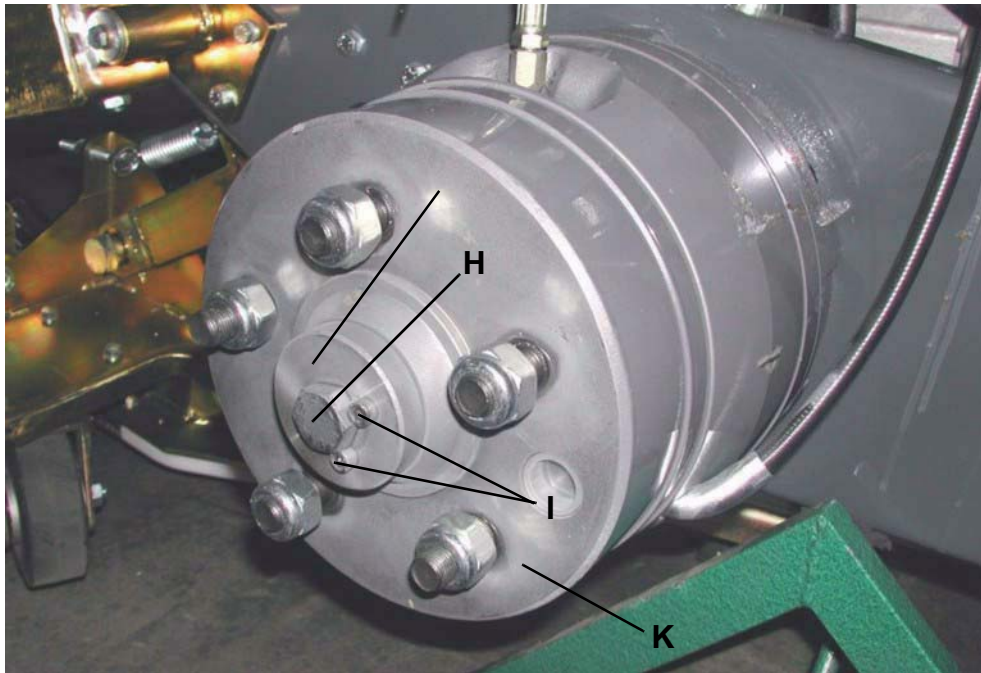

S300885

BRAKE SYSTEM CHECK

1. Check the brake fluid level (see the procedure in the relevant paragraph).
2. Press the brake pedal (57) several times, and check that brakes operate properly.
3. Check that there are no leaks from the brake system.
4. If necessary, check/replace the brakes (see the procedure in relevant paragraph).
5. If necessary, bleed the brake system (see the procedure in the relevant paragraph).

BRAKE SYSTEM

BRAKING MASSES REPLACEMENT

1. Remove the front wheel (see the procedure in the relevant paragraph).
2. Place safety stands under the machine side sill, on the side where the wheel has been removed.
3. Remove the screw (A) and the screws (B), then remove the washer (C).
4. Remove the drum (D).
5. Remove the three springs (E).
6. Remove the shoe retaining springs (F).
7. Remove the shoes (G) together with the braking masses, by disengaging the parking brake control cable (H) from the lever (I).
8. Perform steps 1 to 7 in the reverse order.

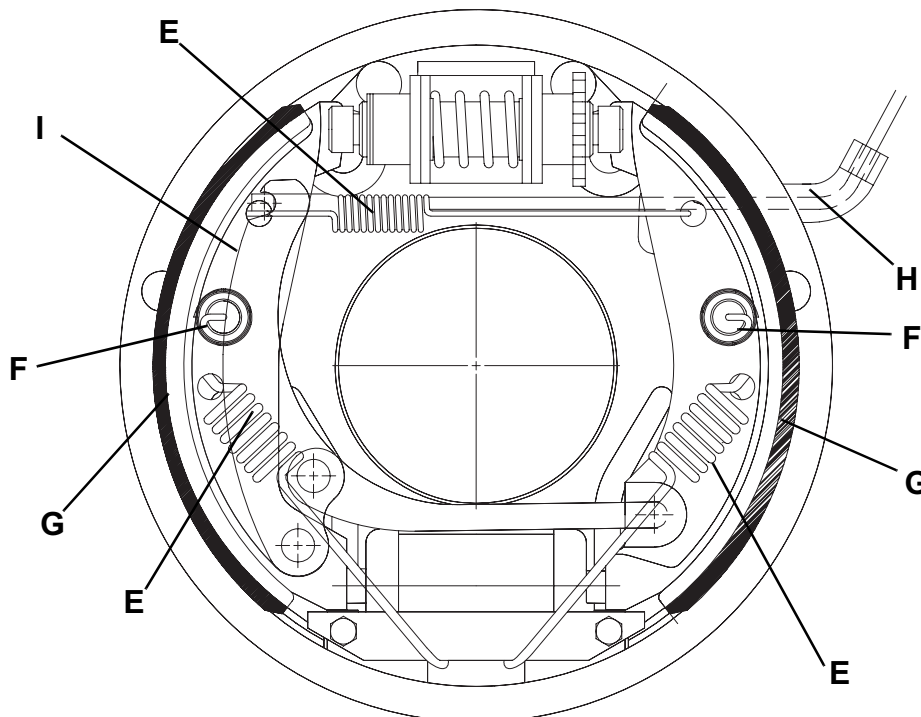
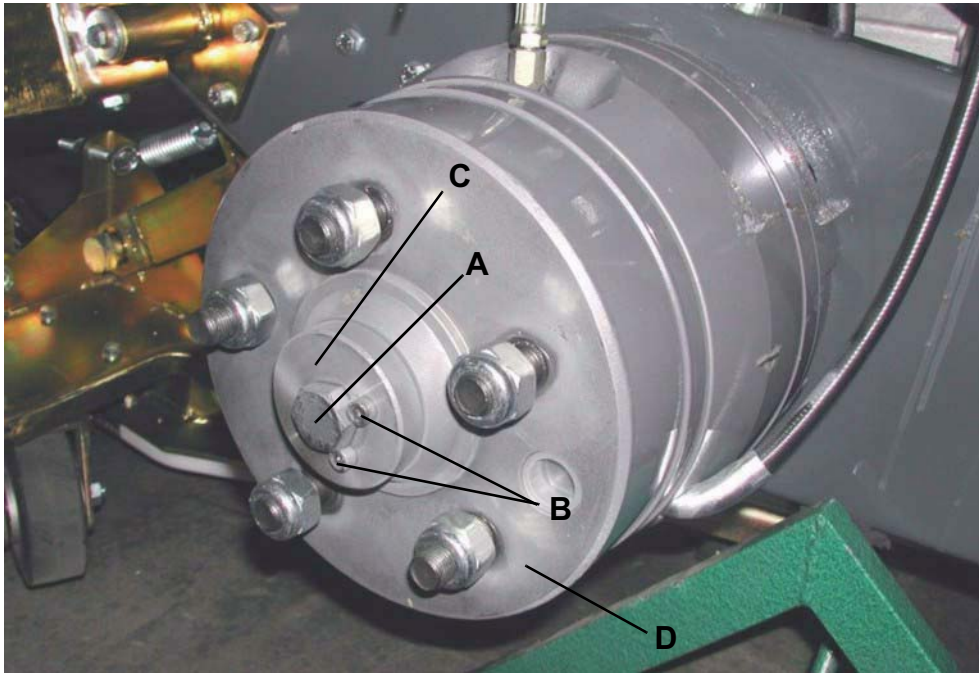

S300886

BRAKE SYSTEM BLEEDING

**WARNING!**

*Brake system bleeding must be always performed with the system opened.
It must also be performed on both front wheels.*

1. Check the brake fluid level (see the procedure in the relevant paragraph).
2. Remove one of the front wheels (see the procedure in the relevant paragraph).
3. Place safety stands under the machine side sill, on the side where the wheel has been removed.
4. Remove the brake system bleed valve plug (A) and connect the pipe (B) to bleed the fluid.
5. Press the brake pedal (57) until the pedal resistance increases. In this condition, keep the pedal pressed and unscrew the valve (A) slightly. Let the oil and air bleed from the pipe (B) into the container (C) until no more air comes out, but oil only. Then screw down the valve (A) and release the brake pedal (57).
6. Perform steps 2 to 4 in the reverse order.
7. Bleed the brake system also on the other front wheel, by performing steps from 2 to 6 again.

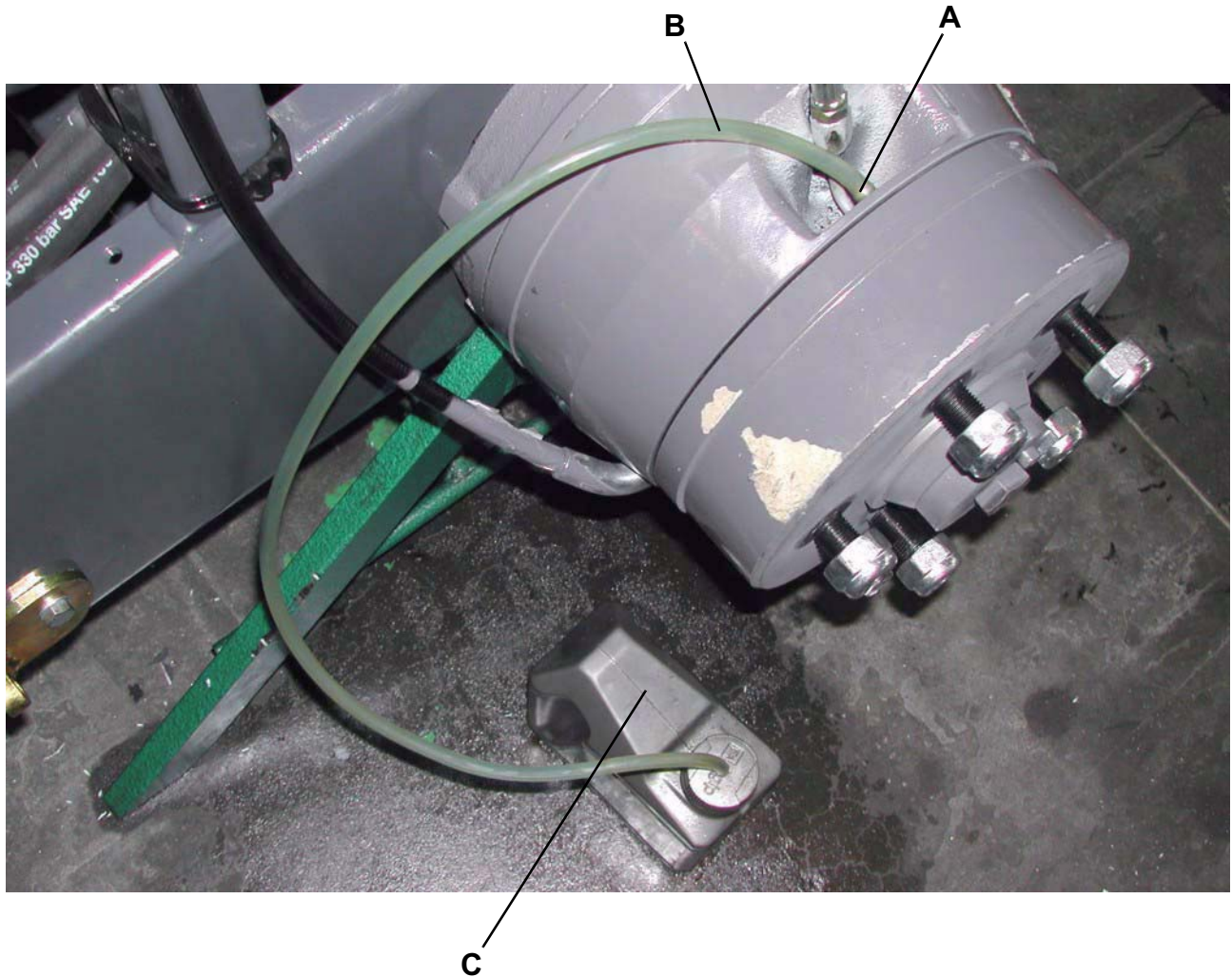

S300887

BRAKE SYSTEM

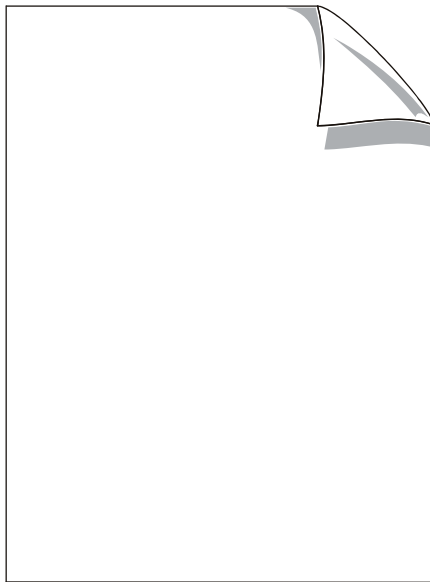

DRIVE SYSTEM

DESCRIPTION

The drive pedal controls two independent drive system hydraulic motors applied to the front wheels. Front and rear wheels are pneumatic.

The drive system consists of:

- A) Drive pedal
- B) Right drive system motor
- C) Left drive system motor
- D) Drive system pump
- E) Hydraulic system oil tank
- F) Hoses

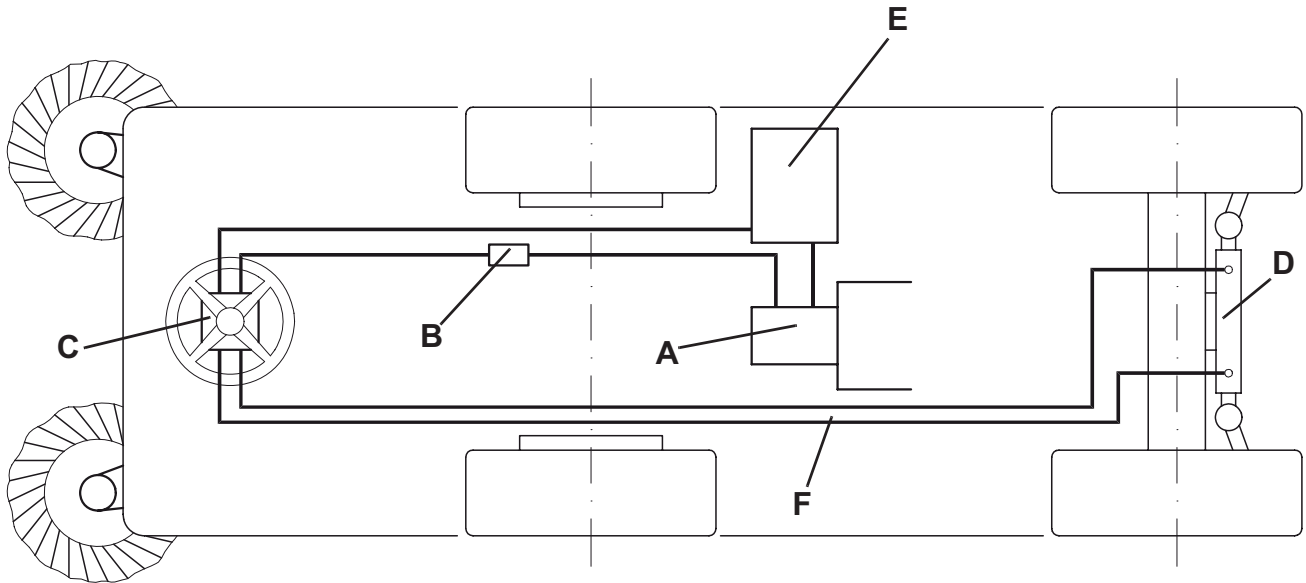

S300878

DRIVE SYSTEM

TROUBLESHOOTING

The machine stability is reduced

Possible causes:

1. The tires are not correctly inflated (check tire pressure).

The rear axle is noisy

Possible causes:

1. The wheel bearings are worn (replace).

The machine power is reduced

Possible causes:

1. The drive system motors are worn (replace).
2. The drive pedal is faulty (replace).
3. The drive system pump power decreases (check the oil pressure at the drive system pump).

The machine does not move

Possible causes:

1. The drive system pump deactivation screw for machine pushing/towing is unscrewed (screw down).
2. There are oil leaks from the hydraulic system (repair).
3. The drive system pump is broken (replace).
4. The drive system motor is broken (replace).

The machine moves even if the drive pedal is released

Possible causes:

1. The drive pedal is misadjusted (adjust).

TIRE PRESSURE CHECK

1. Engage the parking brake with the lever (66).
2. Turn the ignition key (76) to OFF position and remove it.
3. The tire pressure should be as follows:
 - Front tires: 3.75 Bar
 - Rear tires: 3.75 Bar



S301511

DRIVE SYSTEM

REVERSE GEAR BUZZER CHECK AND REVERSE GEAR BUZZER ACTIVATION SENSOR ADJUSTMENT

Check

1. Check that, when the machine moves in reverse, the relevant buzzer sounds.
If necessary, adjust the relevant sensor according to the following procedure.

Adjustment

2. Engage the parking brake with the lever (66).
3. Turn the ignition key (76) to OFF position and remove it.
4. Check that the surface (A) of the sensor (B) is flush with the surface (C) of the drive pedal.
If necessary, loosen the sensor mounting nut (D) and adjust the sensor position. When the adjustment is completed, tighten the nut (D).
5. Check that the distance between the sensor surface (A) and the bracket (E) is within 1.5 and 2.5 mm. When checking, move the drive pedal (F) towards the bracket (E) to cancel the drive pedal end play.
If necessary, loosen the nuts (G) and the nut (H), and adjust the position of the bracket (E). When the adjustment is completed, tighten the nuts (G) and (H).
6. Perform step 1 again.

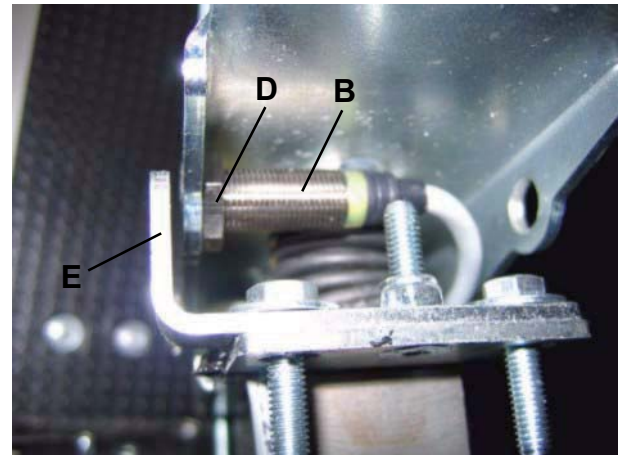
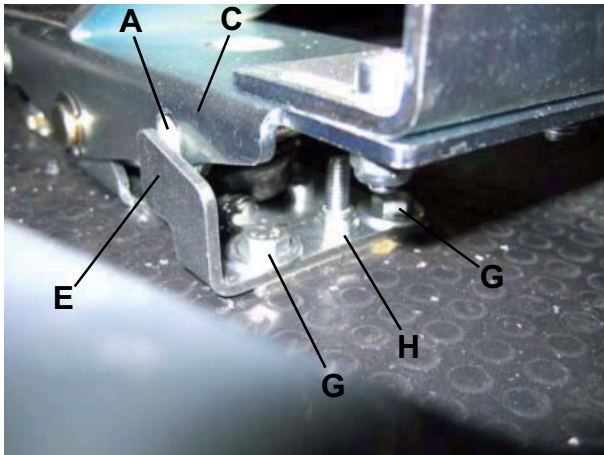
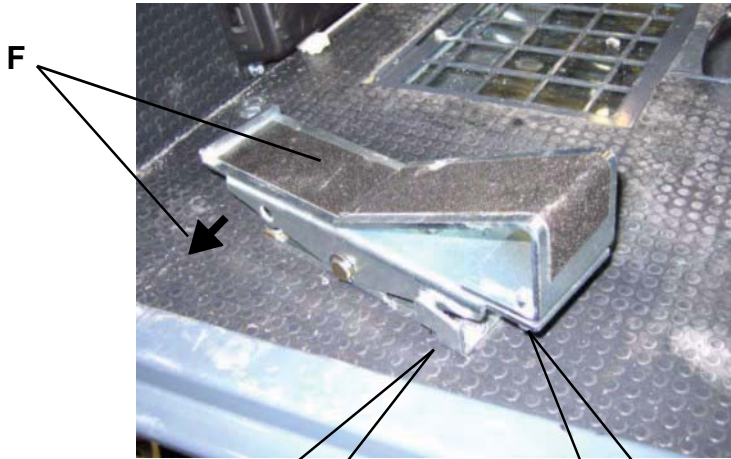

S301410

REVERSE GEAR BUZZER SENSOR DISASSEMBLY/ASSEMBLY**Disassembly**

1. Engage the parking brake with the lever (66).
2. Turn the ignition key (76) to OFF position and remove it.
3. Cut the cable clamp (A) under the right side of the cab.
4. Disconnect the reverse gear buzzer activation sensor connector (B).
5. Remove the four mounting screws (D) of the drive pedal (E).
6. Slightly lift the drive pedal (E) and remove the mounting nut (F) of the sensor (C).
7. Remove the sensor (C), the harness (G) and the connector.

Assembly

8. Assemble the components in the reverse order of disassembly.
9. Adjust the reverse gear buzzer activation sensor (see the procedure in the relevant paragraph).

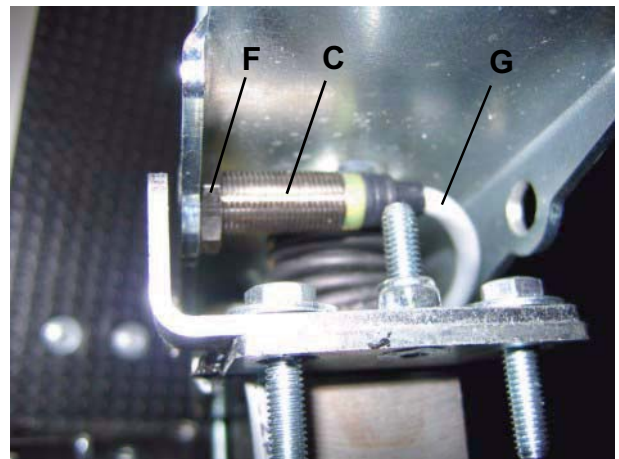
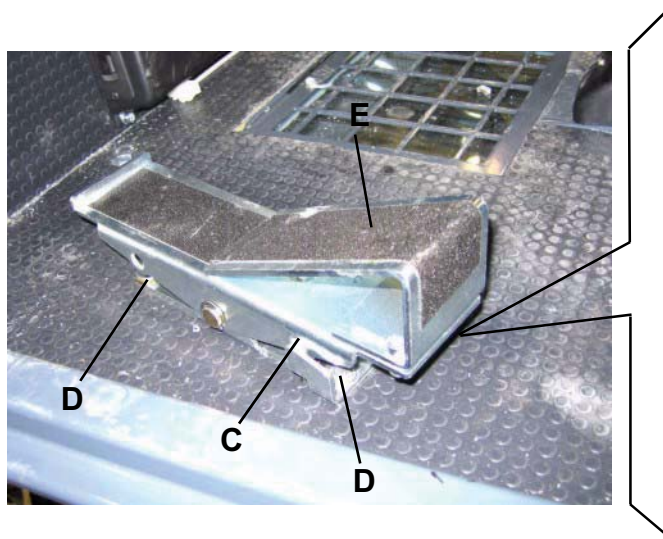
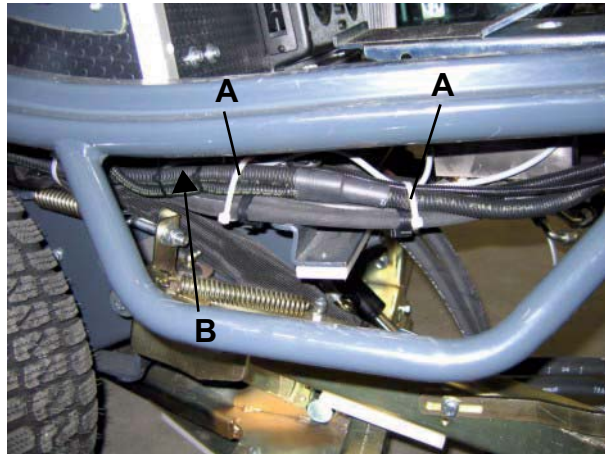

S301411

DRIVE SYSTEM

WHEEL REMOVAL/INSTALLATION

Preliminary operations

1. Turn the ignition key (76) to OFF position and remove it.
2. Engage the parking brake with the lever (66).
3. Check that the machine cannot move with one wheel lifted (the parking brake operates only on the front wheels). If necessary keep the machine stationary by placing wedges on the wheels contacting the ground.
4. Remove the wheel according to the following procedure.

Rear wheel removal/installation

5. Place the jack (A) (not equipped) under the relevant housing (D) in the rear axle (B), as shown in the figure.
6. Carefully activate the jack (A), and lift the wheel (C) until it is slightly detached from the ground.
7. Remove the mounting nuts, then remove the wheel (C).
8. Install the wheel (C) by performing steps from 5 to 7 in the reverse order.
Wheel mounting nut tightening torque: 400 N·m

Front wheel removal/installation

9. Place the jack (E) (not equipped) under the relevant housing (F) on the machine side sill, in front of the wheel (G), as shown in the figure.
10. Carefully activate the jack (E) (not equipped), and lift the wheel (G) until it is slightly detached from the ground.
11. Remove the mounting nuts, then remove the wheel.
12. Install the wheel by performing steps from 9 to 11 in the reverse order.
Wheel mounting nut tightening torque: 400 N·m

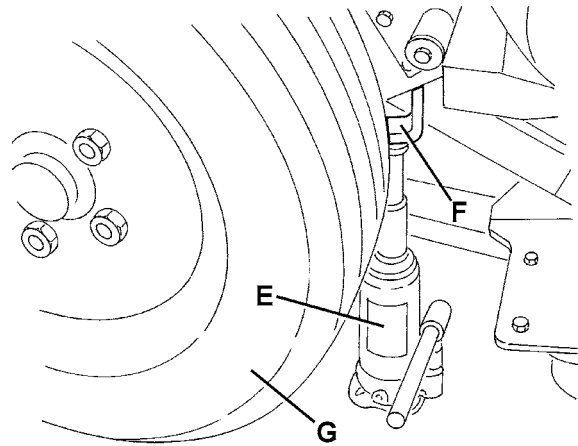
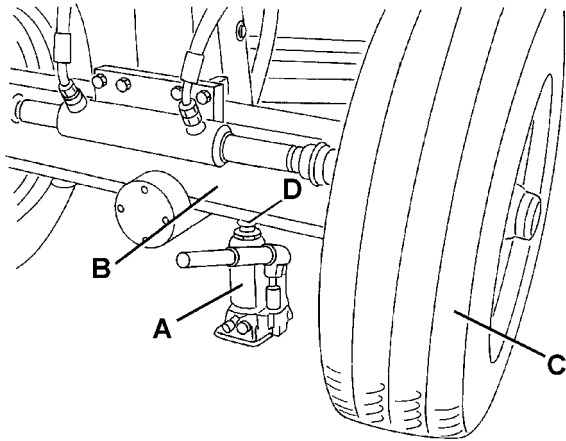

S301412

DRIVE SYSTEM MOTOR DISASSEMBLY/ASSEMBLY

1. Remove the suction inlet (see the procedure in the relevant paragraph).
2. Remove the front wheel (see the procedure in the relevant paragraph). Place safety stands under the machine side sill, on the side where the wheel has been removed.
3. Disconnect the brake system pipes (A) from the brake assembly (B) and plug them immediately.
4. Remove the right or left nut (E), then disconnect the parking brake control cable (C) from the bracket (D).
5. Disconnect the hoses (F) from the drive system motor (B) and plug them immediately.
6. Remove five screws (G), then remove the drive system motor (B) together with the brake.
7. Assemble the components in the reverse order of disassembly and note the following:
 - Before assembling the wheel, bleed the brake system (see the procedure in the relevant paragraph).
8. Check the brake system (see the procedure in the relevant paragraph).
9. Adjust the parking brake (see the procedure in the relevant paragraph).

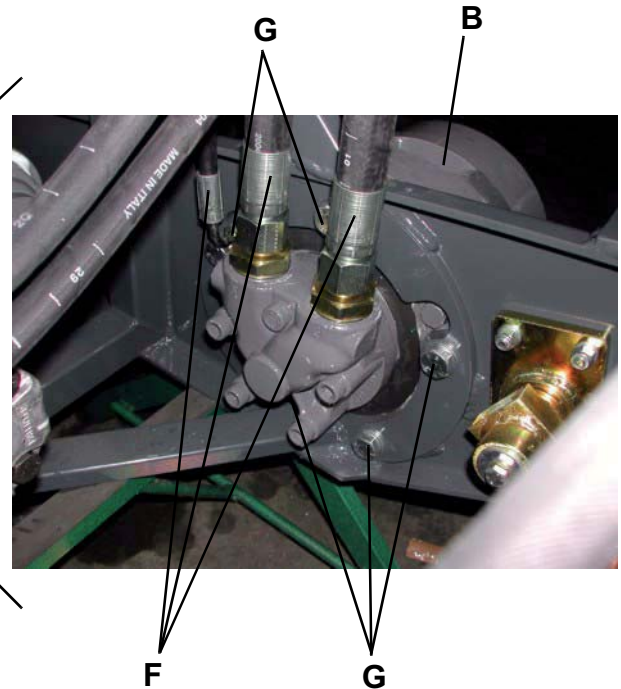
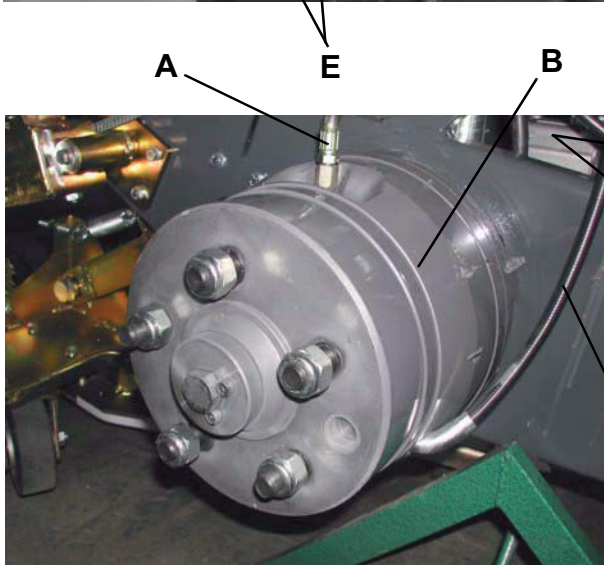
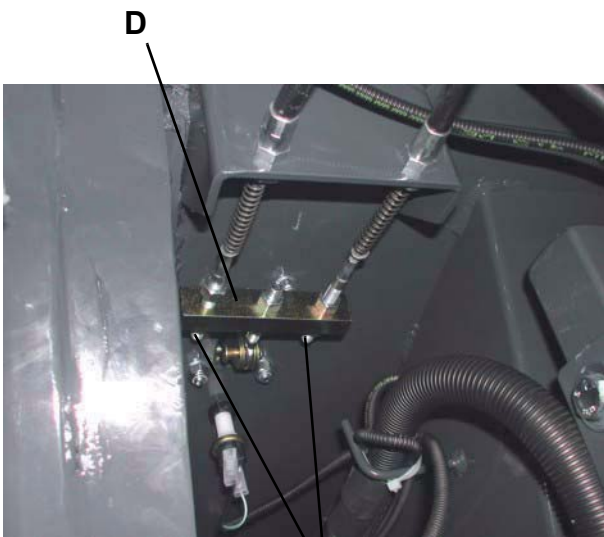

S300891

DRIVE SYSTEM

DRIVE PEDAL CHECK AND ADJUSTMENT

Preliminary operations

1. Empty the hopper (3); if it contains a small quantity of waste, it is not necessary to dump it.

Check

2. Drive the machine on a level and smooth ground, and, with the engine on, check that the machine does not move forward or backward when the drive pedal (56) is not pressed.
If the machine moves, even though slightly, check the drive pedal, according to the following procedure.

Drive pedal check

3. Engage the parking brake with the lever (66).
4. Turn the ignition key (76) to OFF position.
5. Check that the drive pedal (56) turns freely on its shaft and that it does not bind/slow down, which may prevent the pedal from resuming the neutral position.
If necessary, remove the possible cause for binding/slowing down, then repeat step 1.
If the problem persists, adjust the drive system pump as shown below.

Drive system pump adjustment

6. Disengage the parking brake with the lever (66).
7. Stop the left front wheel with two wedges (A).
8. Remove the right front wheel according to the procedure shown in the relevant paragraph.
9. Place safety stands under the machine side sill, on the side where the wheel has been removed.
10. Lift the hopper (3) for 20 cm, according to the procedure shown in the User Manual.
11. Turn the ignition key (76) to OFF position and remove it.
12. Open the right lid (20) by releasing the fasteners (21) with the supplied key.
13. Empty the dust control system water tanks (7 and 16) according to the procedure shown in the relevant paragraph.
14. Remove the screw (44) and open the right tank (43).

**WARNING!**

Open the tanks (7 and 16) only if they are empty: each tank contains 120 kg of water approximately.

15. Turn on the diesel engine with care.

**WARNING!**

When the diesel engine is running, the wheel hub (B) can be rotating.

16. Check that the machine is in the following conditions:

- Diesel engine is running
- Drive pedal (56) is not pressed
- Brakes and parking brake are not activated

In these conditions, operating on the drive system pump (C), loosen the locknut (D) then turn the threaded dowel (E) clockwise or counter-clockwise, until the hub (B) stops.

Tighten the locknut (D).

17. Engage the parking brake with the lever (66).
18. Turn the ignition key (76) to OFF position.
19. Perform steps 6 to 12 in the reverse order.
20. Perform step 1 again.
21. If necessary, fill the dust control system water tanks according to the procedure shown in the User Manual.

DRIVE PEDAL CHECK AND ADJUSTMENT (Continues)

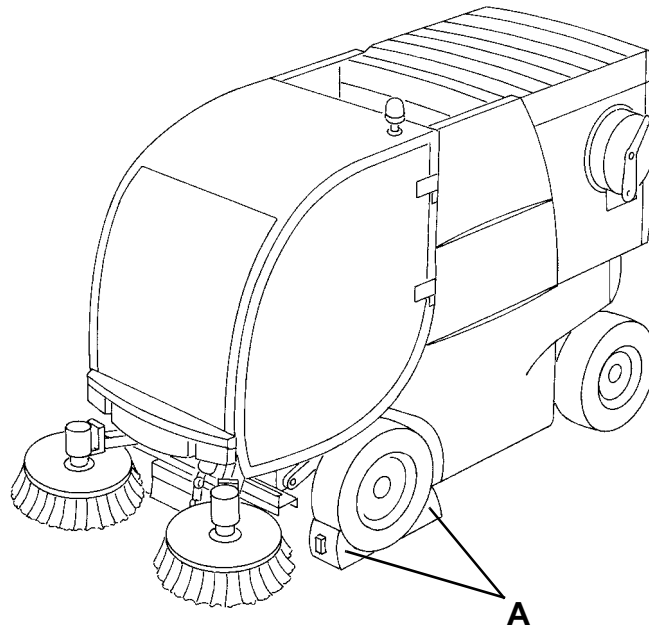

S301494

DRIVE SYSTEM

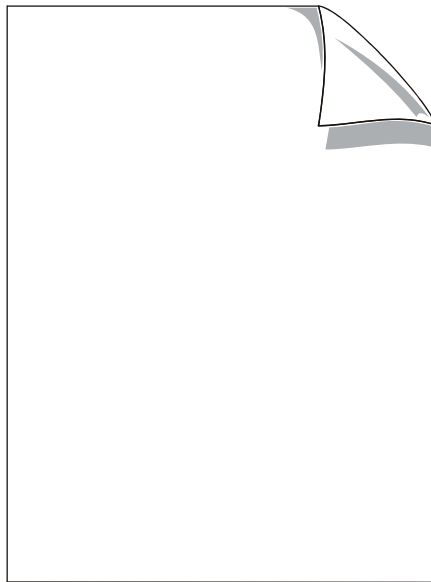

LDW 1603/B2 ENGINE

DESCRIPTION

The machine is equipped with a diesel engine, which activates the hydraulic system pumps. For diesel engine data see the Technical Data chapter and the Diesel Engine Manual.

The following pumps are connected to the engine:

- A) Accessory and steering system pump
- B) Suction fan pump
- C) Drive system pump

The fuel filter is located on the machine frame.

For machines equipped with climate control system, besides the alternator control pulley, there is also the compressor control pulley (D).

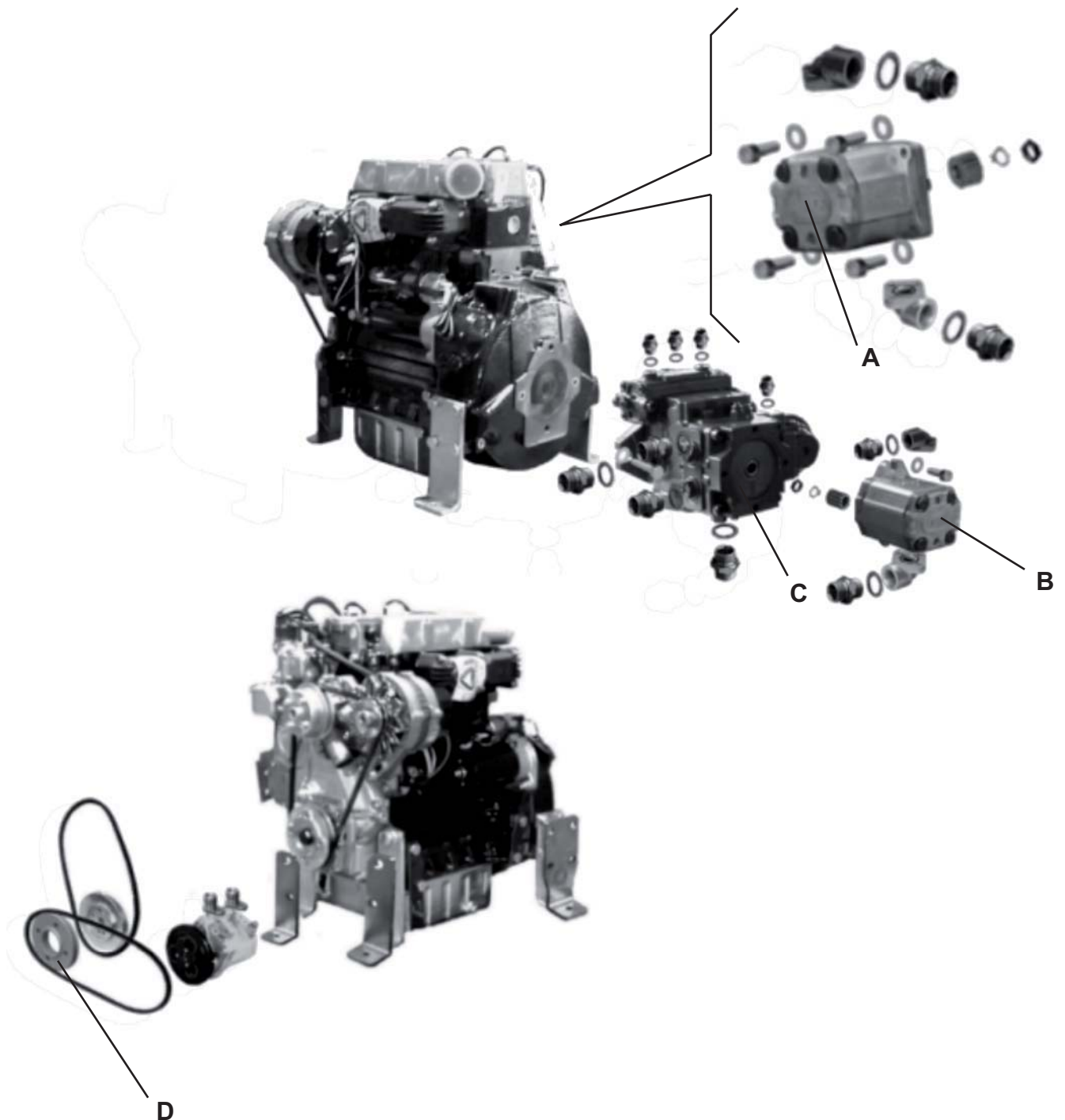

LDW 1603/B2 ENGINE

TROUBLESHOOTING

The diesel engine does not start

Possible causes:

1. The drive pedal is pressed (release).
2. The sensor for engine start-up inhibition is misadjusted/broken (adjust/replace).



NOTE

For diesel engine complete troubleshooting, see the relevant Manual.

ENGINE OIL LEVEL CHECK

1. Empty the hopper (3); if it contains a small quantity of waste, it is not necessary to dump it.
2. Drive the machine on a solid and level ground, then engage the parking brake with the lever (66).
3. Lift the hopper (3), according to the procedure shown in the User Manual.
4. Turn the ignition key (76) to OFF position and remove it.
5. Open the left lid (18) by releasing the fasteners (19) with the supplied key.
6. Remove the locking pins (28) from the housings (29) and place them into the holes (30).
7. Empty the dust control system water tanks (7 and 16) according to the procedure shown in the relevant paragraph.
8. Remove the screw (49) and open the left tank (41).

**WARNING!**

Open the tanks (7 and 16) only if they are empty: each tank contains 120 kg of water approximately.

9. Check the oil level according to the procedure shown in the Diesel Engine Manual.
10. If necessary, add oil according to the procedure shown in the Diesel Engine Manual.
11. Perform steps 3, 4, 5, 6 and 8 in the reverse order.
12. If necessary, fill the dust control system water tanks according to the procedure shown in the User Manual.

LDW 1603/B2 ENGINE

ENGINE OIL CHANGE

1. Empty the hopper (3); if it contains a small quantity of waste, it is not necessary to dump it.
2. Drive the machine on a solid and level ground, then engage the parking brake with the lever (66).
3. Lift the hopper (3), according to the procedure shown in the User Manual.
4. Turn the ignition key (76) to OFF position and remove it.
5. Open the right and left lids (20) and (18) by releasing the fasteners (21) and (19) with the supplied key.
6. Remove the locking pins (28) from the housings (29) and place them into the holes (30).
7. Empty the dust control system water tanks (7 and 16) according to the procedure shown in the relevant paragraph.
8. Remove the screw (44) and open the right tank (43).

**WARNING!**

Open the tanks (7 and 16) only if they are empty: each tank contains 120 kg of water approximately.

9. Change oil according to the procedure shown in the Diesel Engine Manual.
10. Perform steps 3, 4, 5, 6 and 8 in the reverse order.
11. If necessary, fill the dust control system water tanks according to the procedure shown in the User Manual.

ENGINE OIL FILTER CHANGE**NOTE**

This procedure must be performed when the engine oil has been drained.

1. Empty the hopper (3); if it contains a small quantity of waste, it is not necessary to dump it.
2. Drive the machine on a solid and level ground, then engage the parking brake with the lever (66).
3. Lift the hopper (3), according to the procedure shown in the User Manual.
4. Turn the ignition key (76) to OFF position and remove it.
5. Open the left lid (18) by releasing the fasteners (19) with the supplied key.
6. Remove the locking pins (28) from the housings (29) and place them into the holes (30).
7. Empty the dust control system water tanks (7 and 16) according to the procedure shown in the relevant paragraph.
8. Remove the screw (42) and open the left tank (41).

**WARNING!**

Open the tanks (7 and 16) only if they are empty: each tank contains 120 kg of water approximately.

9. Replace the oil filter according to the procedure shown in the Diesel Engine Manual.
10. Perform steps 3, 4, 5, 6 and 8 in the reverse order.
11. If necessary, fill the dust control system water tanks according to the procedure shown in the User Manual.

LDW 1603/B2 ENGINE

ENGINE COOLANT LEVEL CHECK

1. Empty the hopper (3); if it contains a small quantity of waste, it is not necessary to dump it.
2. Drive the machine on a solid and level ground, then engage the parking brake with the lever (66).
3. Lift the hopper (3), according to the procedure shown in the User Manual.
4. Turn the ignition key (76) to OFF position and remove it.
5. Open the left lid (18) by releasing the fasteners (19) with the supplied key.
6. Remove the locking pins (28) from the housings (29) and place them into the holes (30).

**WARNING!**

The coolant line is pressurised; do not perform any check until the engine has cooled down and, even if the engine is cold, the tank plug (B) must be opened with extreme care.

7. Check that the coolant level in the tank (A) is between the minimum and maximum marks, according to the procedure shown in the Diesel Engine Manual. If necessary, unscrew the plug (B) and top up.

Coolant components:

- 50% of AGIP antifreeze
- 50% of water

After top up, tighten the plug (B).

8. Perform steps 3 to 6 in the reverse order.

**B****A**

S300894

ENGINE AIR FILTER CLEANING**WARNING!**

Protect body parts (eyes, hair, hands, etc.) properly, when performing cleaning operations using compressed air gun.

Preliminary operations

1. Engage the parking brake with the lever (66).
2. Turn the ignition key (76) to OFF position and remove it.
3. Open the left lid (18) by releasing the fasteners (19) with the supplied key.

Pre-filter cleaning

4. Remove the screw (A), then remove the pre-filter (B).
5. Clean and wash the pre-filter, then install it.

Filter cleaning

6. Remove the screw (C), then remove the cover (D).
7. Remove the outer filter (E) and the inner filter (F).
8. Clean the filters (E) and (F) carefully with compressed air (maximum 6 Bar) and replace them, if necessary.
9. Install the filters (E) and (F).
10. Install the cover (D) and the screw (C).
11. Close the left lid (18) by engaging the fasteners (19) with the supplied key.

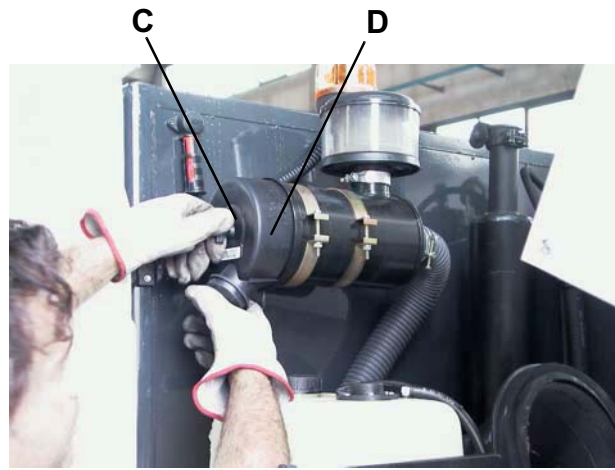
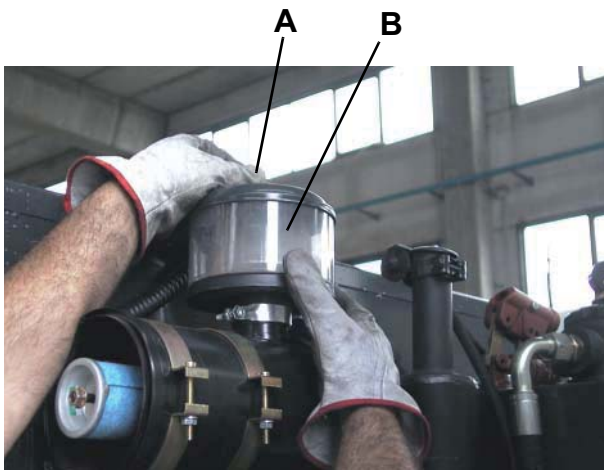

S300895

LDW 1603/B2 ENGINE

FUEL FILTER REPLACEMENT

1. Empty the hopper (3); if it contains a small quantity of waste, it is not necessary to dump it.
2. Drive the machine on a solid and level ground, then engage the parking brake with the lever (66).
3. Lift the hopper (3), according to the procedure shown in the User Manual.
4. Turn the ignition key (76) to OFF position and remove it.
5. Open the left lid (18) by releasing the fasteners (19) with the supplied key.
6. Remove the locking pins (28) from the housings (29) and place them into the holes (30).
7. Empty the dust control system water tanks (7 and 16) according to the procedure shown in the relevant paragraph.
8. Remove the screw (42) and open the left tank (41).

**WARNING!**

Open the tanks (7 and 16) only if they are empty: each tank contains 120 kg of water approximately.

9. Replace the fuel filter according to the procedure shown in the Diesel Engine Manual.
10. Perform steps 3, 4, 5, 6 and 8 in the reverse order.
11. If necessary, fill the dust control system water tanks according to the procedure shown in the User Manual.

FUEL FITTING AND SCREW CHECK

1. Empty the hopper (3); if it contains a small quantity of waste, it is not necessary to dump it.
2. Drive the machine on a solid and level ground, then engage the parking brake with the lever (66).
3. Lift the hopper (3), according to the procedure shown in the User Manual.
4. Turn the ignition key (76) to OFF position and remove it.
5. Open the left lid (18) by releasing the fasteners (19) with the supplied key.
6. Remove the locking pins (28) from the housings (29) and place them into the holes (30).
7. Empty the dust control system water tanks (7 and 16) according to the procedure shown in the relevant paragraph.
8. Remove the screw (42) and open the left tank (41).

**WARNING!**

Open the tanks (7 and 16) only if they are empty: each tank contains 120 kg of water approximately.

9. Operating on the fuel filter (A) and on the diesel engine, check the sealing of fuel system fittings (B). Repair if necessary.
10. Operating on the fuel tank (C), check the sealing of fuel system fittings (D). Repair if necessary.
11. Perform steps 3, 4, 5, 6 and 8 in the reverse order.
12. If necessary, fill the dust control system water tanks according to the procedure shown in the User Manual.

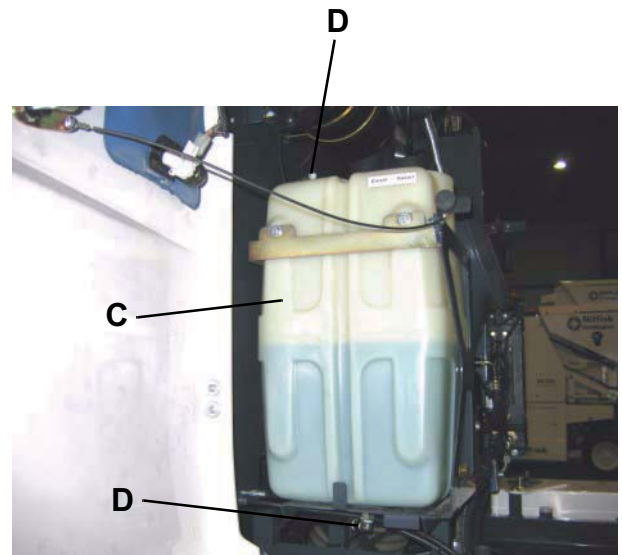
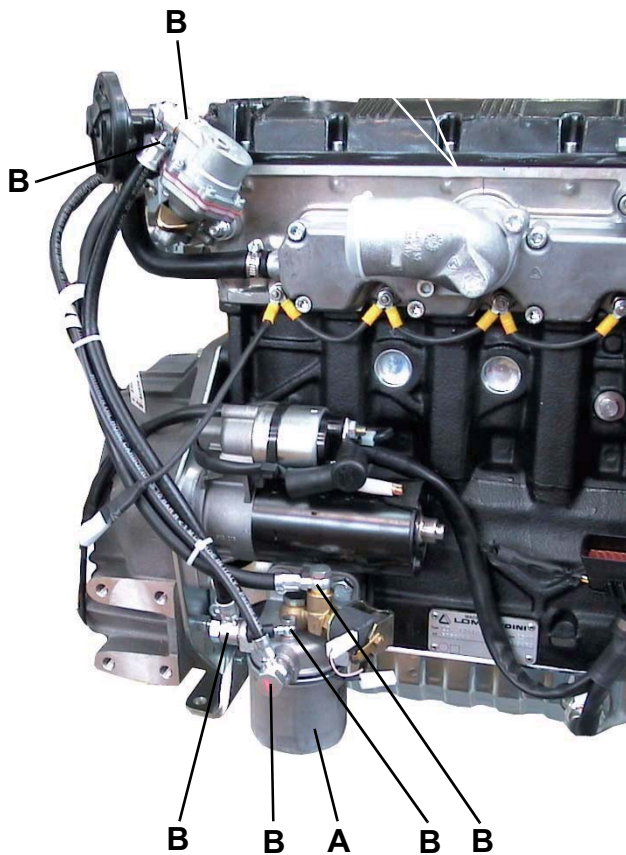

S301656

LDW 1603/B2 ENGINE

ALTERNATOR BELT TENSION CHECK

1. Empty the hopper (3); if it contains a small quantity of waste, it is not necessary to dump it.
2. Drive the machine on a solid and level ground, then engage the parking brake with the lever (66).
3. Lift the hopper (3), according to the procedure shown in the User Manual.
4. Turn the ignition key (76) to OFF position and remove it.
5. Open the right lid (20) by releasing the fasteners (21) with the supplied key.
6. Remove the locking pins (28) from the housings (29) and place them into the holes (30).
7. Empty the dust control system water tanks (7 and 16) according to the procedure shown in the relevant paragraph.
8. Remove the screw (44) and open the right tank (43).

**WARNING!**

Open the tanks (7 and 16) only if they are empty: each tank contains 120 kg of water approximately.

9. Check and, if necessary, adjust the alternator belt tension according to the procedure shown in the Diesel Engine Manual.
10. Perform steps 3, 4, 5, 6 and 8 in the reverse order.
11. If necessary, fill the dust control system water tanks according to the procedure shown in the User Manual.

ALTERNATOR BELT REPLACEMENT

1. Empty the hopper (3); if it contains a small quantity of waste, it is not necessary to dump it.
2. Drive the machine on a solid and level ground, then engage the parking brake with the lever (66).
3. Lift the hopper (3), according to the procedure shown in the User Manual.
4. Turn the ignition key (76) to OFF position and remove it.
5. Open the right lid (20) by releasing the fasteners (21) with the supplied key.
6. Remove the locking pins (28) from the housings (29) and place them into the holes (30).
7. Empty the dust control system water tanks (7 and 16) according to the procedure shown in the relevant paragraph.
8. Remove the screw (44) and open the right tank (43).

**WARNING!**

Open the tanks (7 and 16) only if they are empty: each tank contains 120 kg of water approximately.

9. Replace and adjust the alternator belt tension according to the procedure shown in the Diesel Engine Manual.
10. Perform steps 3, 4, 5, 6 and 8 in the reverse order.
11. If necessary, fill the dust control system water tanks according to the procedure shown in the User Manual.

LDW 1603/B2 ENGINE

RADIATOR FIN CLEANING CHECK

1. Empty the hopper (3); if it contains a small quantity of waste, it is not necessary to dump it.
2. Drive the machine on a solid and level ground, then engage the parking brake with the lever (66).
3. Lift the hopper (3), according to the procedure shown in the User Manual.
4. Turn the ignition key (76) to OFF position and remove it.
5. Open the right and left lids (20) and (18) by releasing the fasteners (21) and (19) with the supplied key.
6. Remove the locking pins (28) from the housings (29) and place them into the holes (30).
7. Empty the dust control system water tanks (7 and 16) according to the procedure shown in the relevant paragraph.
8. On both sides of the machine, loosen the screws (42 and 44), and open the right and left tanks (41 and 43).

**WARNING!**

Open the tanks (7 and 16) only if they are empty: each tank contains 120 kg of water approximately.

9. Check the radiator fin cleaning according to the procedure shown in the Diesel Engine Manual.
10. Perform steps 3, 4, 5, 6 and 8 in the reverse order.
11. If necessary, fill the dust control system water tanks according to the procedure shown in the User Manual.

ENGINE COOLANT LINE SLEEVE CHECK

1. Empty the hopper (3); if it contains a small quantity of waste, it is not necessary to dump it.
2. Drive the machine on a solid and level ground, then engage the parking brake with the lever (66).
3. Lift the hopper (3), according to the procedure shown in the User Manual.
4. Turn the ignition key (76) to OFF position and remove it.
5. Open the right and left lids (20) and (18) by releasing the fasteners (21) and (19) with the supplied key.
6. Remove the locking pins (28) from the housings (29) and place them into the holes (30).
7. Empty the dust control system water tanks (7 and 16) according to the procedure shown in the relevant paragraph.
8. Remove the screws (44) and (42) and open the right (43) and left tank (41).

**WARNING!**

Open the tanks (7 and 16) only if they are empty: each tank contains 120 kg of water approximately.

9. Check the coolant line sleeves according to the procedure shown in the Diesel Engine Manual.
10. Perform steps 3, 4, 5, 6 and 8 in the reverse order.
11. If necessary, fill the dust control system water tanks according to the procedure shown in the User Manual.

LDW 1603/B2 ENGINE

ENGINE COOLANT CHANGE

1. Empty the hopper (3); if it contains a small quantity of waste, it is not necessary to dump it.
2. Drive the machine on a solid and level ground, then engage the parking brake with the lever (66).
3. Lift the hopper (3), according to the procedure shown in the User Manual.
4. Turn the ignition key (76) to OFF position and remove it.
5. Open the right and left lids (20) and (18) by releasing the fasteners (21) and (19) with the supplied key.
6. Remove the locking pins (28) from the housings (29) and place them into the holes (30).
7. Empty the dust control system water tanks (7 and 16) according to the procedure shown in the relevant paragraph.
8. Remove the screw (42) and open the left tank (41).

**WARNING!**

Open the tanks (7 and 16) only if they are empty: each tank contains 120 kg of water approximately.

9. Change the engine coolant according to the procedure shown in the Diesel Engine Manual.
10. Perform steps 3, 4, 5, 6 and 8 in the reverse order.
11. If necessary, fill the dust control system water tanks according to the procedure shown in the User Manual.

INJECTOR CALIBRATION AND CLEANING

1. Empty the hopper (3); if it contains a small quantity of waste, it is not necessary to dump it.
2. Drive the machine on a solid and level ground, then engage the parking brake with the lever (66).
3. Lift the hopper (3), according to the procedure shown in the User Manual.
4. Turn the ignition key (76) to OFF position and remove it.
5. Open the left lid (18) by releasing the fasteners (19) with the supplied key.
6. Remove the locking pins (28) from the housings (29) and place them into the holes (30).
7. Empty the dust control system water tanks (7 and 16) according to the procedure shown in the relevant paragraph.
8. Remove the screw (42) and open the left tank (41).

**WARNING!**

Open the tanks (7 and 16) only if they are empty: each tank contains 120 kg of water approximately.

9. Calibrate and clean the injectors according to the procedure shown in the Diesel Engine Manual.
10. Perform steps 3 to 6 and 8 in the reverse order.
11. If necessary, fill the dust control system water tanks according to the procedure shown in the User Manual.

LDW 1603/B2 ENGINE

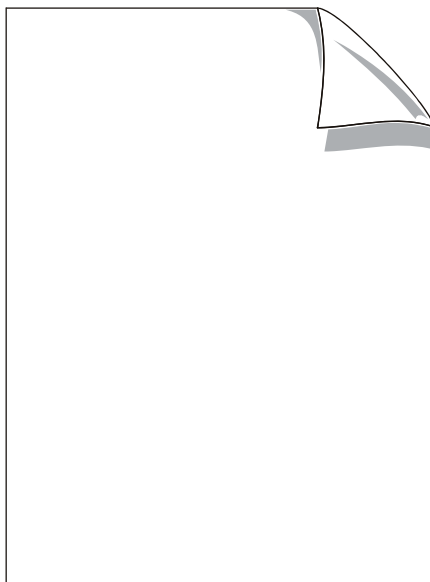

CLIMATE CONTROL SYSTEM

DESCRIPTION

The climate control system consists of:

- A) Compressor
- B) Condenser
- C) Cooler
- D) Expansion valve
- E) Filter drier
- F) High pressure hose
- G) Low pressure hose
- H) High pressure connection
- I) Low pressure connection
- J) Cooling controls
- K) Heating controls
- L) Heater
- M) Air filter

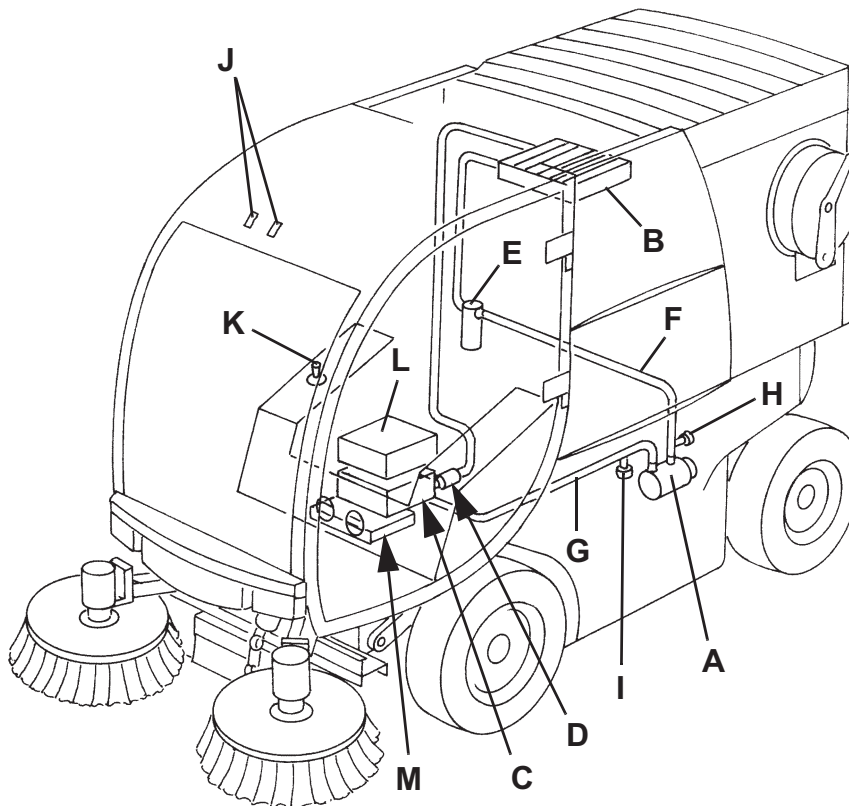

S300899

CLIMATE CONTROL SYSTEM

TROUBLESHOOTING

No fresh air from the climate control system

Possible causes:

1. The compressor does not turn because the drive belt is loosen/broken (tension/replace the belt).
2. There are gas leaks from the system (repair the leak and integrate the gas).
3. The expansion valve is faulty (replace).

No hot air from the climate control system

Possible causes:

1. The hot water hoses are broken (replace).
2. There are water leaks from the heater (replace).

CLIMATE CONTROL SYSTEM

COMPRESSOR BELT TENSION CHECK (LDW 1603/B2 engine)

1. Empty the hopper (3); if it contains a small quantity of waste, it is not necessary to dump it.
2. Drive the machine on a solid and level ground, then engage the parking brake with the lever (66).
3. Lift the hopper (3), according to the procedure shown in the User Manual.
4. Turn the ignition key (76) to OFF position and remove it.
5. Open the right lid (20) by releasing the fasteners (21) with the supplied key.
6. Remove the locking pins (28) from the housings (29) and place them into the holes (30).
7. Empty the dust control system water tanks (7 and 16) according to the procedure shown in the relevant paragraph.
8. Remove the screw (44) and open the right tank (43).

**WARNING!**

Open the tanks (7 and 16) only if they are empty: each tank contains 120 kg of water approximately.

9. Check the tension of the belt (A) of the compressor (B) according to the following procedure:
 - Press the belt in the intermediate position (C) with a force of 10 kg and check that the belt does not bend for more than 1 cm.
 If necessary, loosen the nuts (D) and (E), and adjust the tension of the belt (A). Tighten the nuts (D) and (E).
10. Perform steps 3, 4, 5, 6 and 8 in the reverse order.
11. If necessary, fill the dust control system water tanks according to the procedure shown in the User Manual.

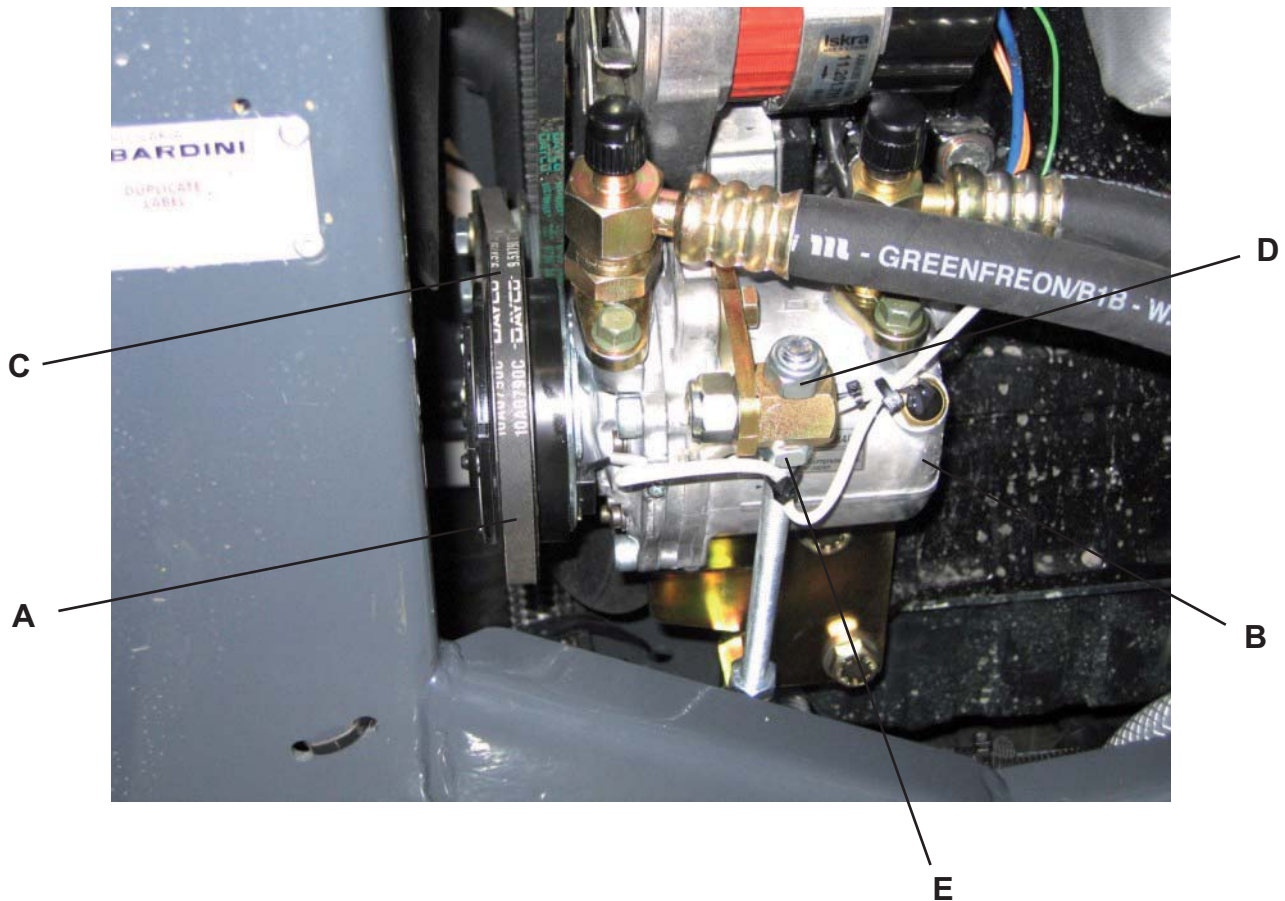

S301415

CLIMATE CONTROL SYSTEM

COMPRESSOR BELT REPLACEMENT (LDW 1603/B2 engine)

1. Empty the hopper (3); if it contains a small quantity of waste, it is not necessary to dump it.
2. Drive the machine on a solid and level ground, then engage the parking brake with the lever (66).
3. Lift the hopper (3), according to the procedure shown in the User Manual.
4. Turn the ignition key (76) to OFF position and remove it.
5. Open the left lid (18) by releasing the fasteners (19) with the supplied key.
6. Remove the locking pins (28) from the housings (29) and place them into the holes (30).
7. Empty the dust control system water tanks (7 and 16) according to the procedure shown in the relevant paragraph.
8. Remove the screw (42) and open the left tank (41).

**WARNING!**

Open the tanks (7 and 16) only if they are empty: each tank contains 120 kg of water approximately.

9. Loosen the tensioning nuts (A) of the belt (B) of the compressor (C).
10. Remove the belt (B) from the pulleys.
11. Place the new belt (B) on the pulleys.
12. Adjust the compressor belt tension according to the procedure shown in the previous paragraph.
13. Perform steps 3, 4, 5, 6 and 8 in the reverse order.
14. If necessary, fill the dust control system water tanks according to the procedure shown in the User Manual.

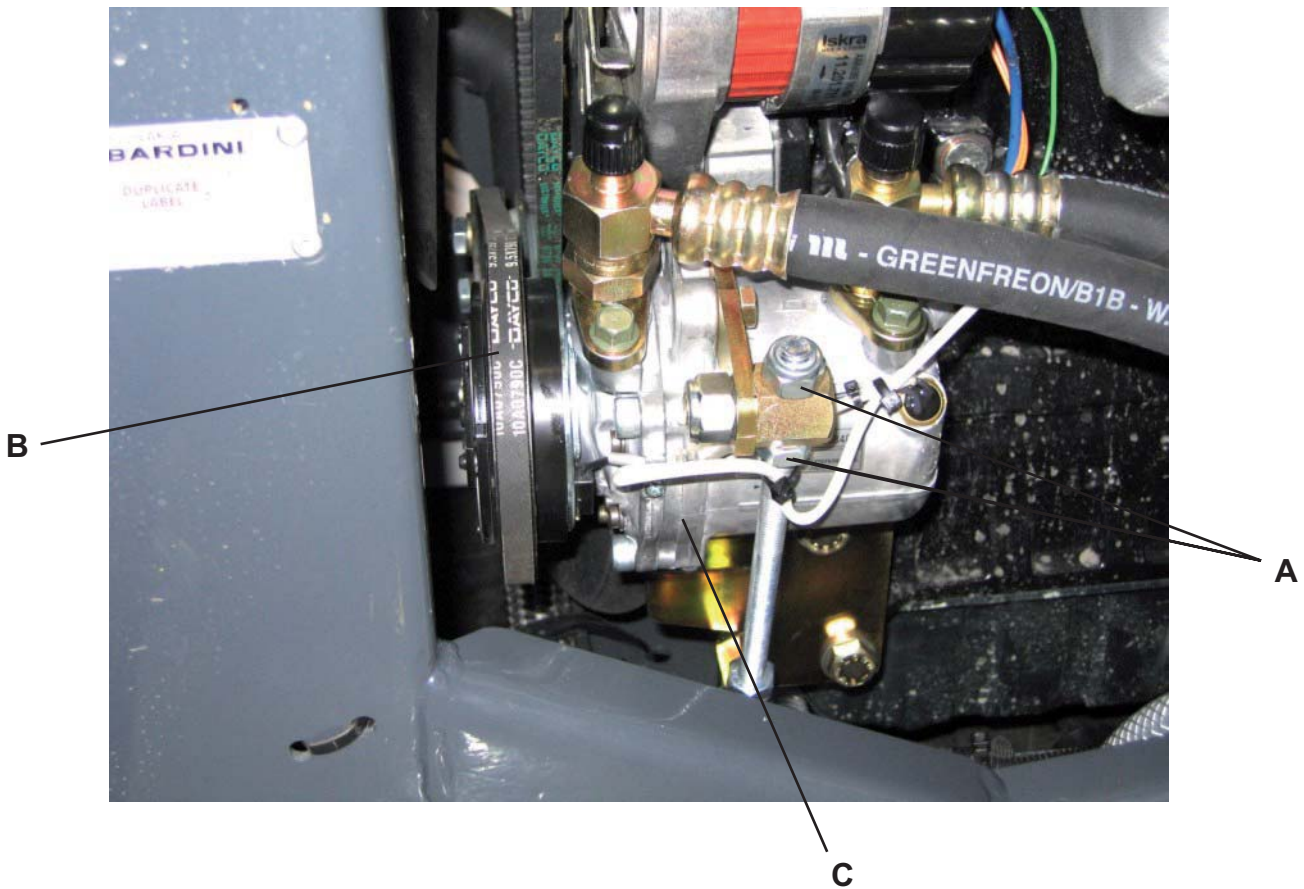

S301415

CLIMATE CONTROL SYSTEM

AIR FILTER REPLACEMENT

1. Engage the parking brake with the lever (66).
2. Turn the ignition key (76) to OFF position and remove it.
3. Remove the screws (A) and the panel (B) in the cab.
4. Unscrew the knobs (F) and remove the panel (C).
5. Remove the cab air filter (D).
6. Install the new filter (D) with the arrows (E) pointing in the direction of the air flow (upwards).
7. Perform steps 3 and 4 in the reverse order.

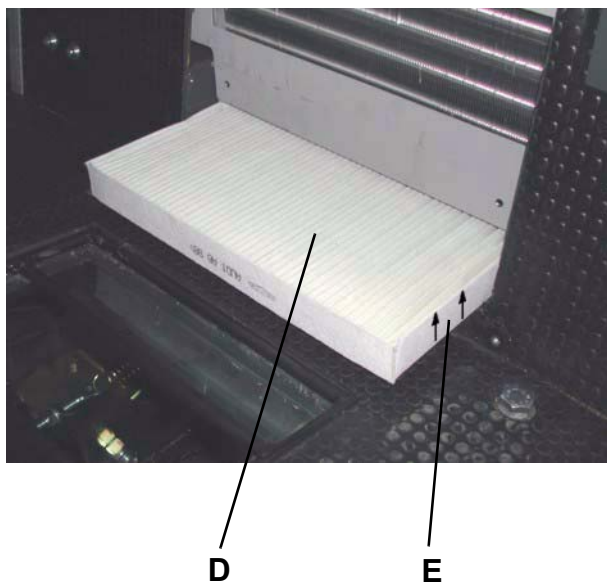
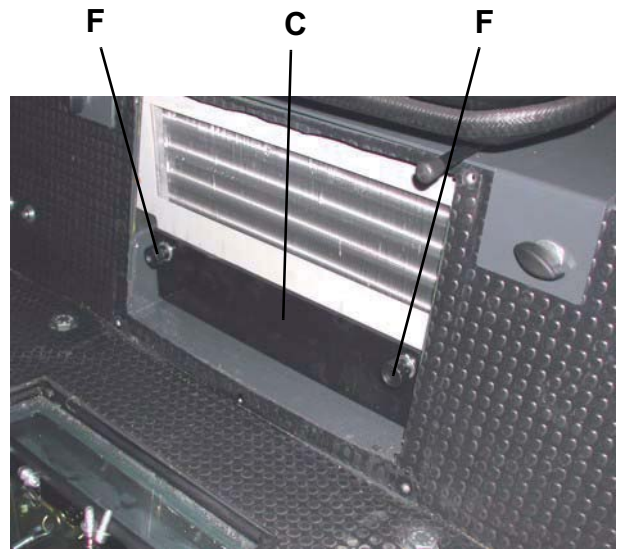
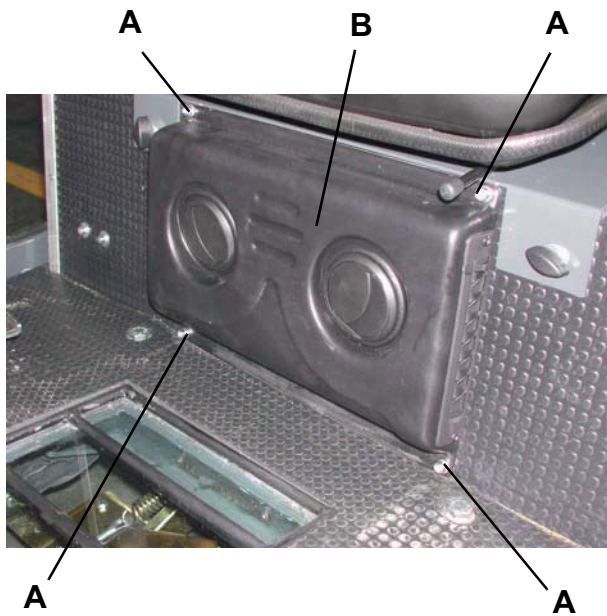

S300902

CLIMATE CONTROL SYSTEM

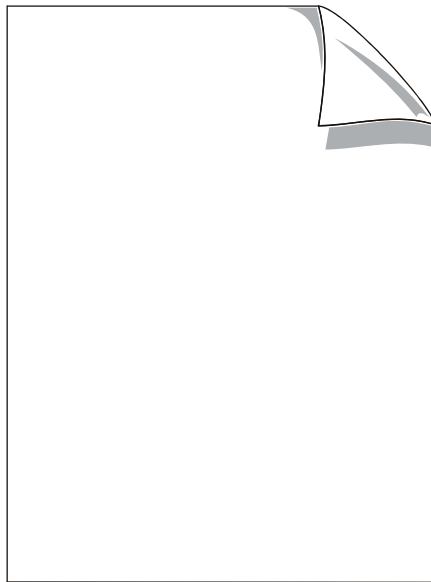

OTHER SYSTEMS

NUT AND SCREW TIGHTENING AND LEAKAGE CHECK

1. Empty the hopper (3); if it contains a small quantity of waste, it is not necessary to dump it.
2. Drive the machine on a solid and level ground, then engage the parking brake with the lever (66).
3. Open the right and left lids (20) and (18) by releasing the fasteners (21) and (19) with the supplied key.
4. Lift the hopper (3), according to the procedure shown in the User Manual.
5. Turn the ignition key (76) to OFF position and remove it.
6. Remove the locking pins (28) from the housings (29) and place them into the holes (30).
7. Empty the dust control system water tanks (7 and 16) according to the procedure shown in the relevant paragraph.
8. Remove the screw (44) and open the right tank (43).

**WARNING!**

Open the tanks (7 and 16) only if they are empty: each tank contains 120 kg of water approximately.

9. Remove the screw (42) and open the left tank (41).
10. Inspect the machine accessible parts and check for:
 - Tightening of mounting screws and nuts;
 - Correct position of the fasteners;
 - Visible faults in the components;
 - Leaks of fluids (oil, etc.).
11. Perform steps 3, 4, 5, 6 and 8 in the reverse order.
12. If necessary, fill the dust control system water tanks according to the procedure shown in the User Manual.

OTHER SYSTEMS

LUBRICATION

1. Drive the machine on a solid and level ground, then engage the parking brake with the lever (66).
2. Turn the ignition key (76) to OFF position and remove it.
3. Lubricate the rear axle knuckles with the grease nipples (A). If necessary, steer the rear wheels to reach the grease nipples easily.

Grease quantity to be applied:

- 2 - 3 pumping, in case of a manual pump.
- 8 - 12 seconds of injection, in case of an air pump.

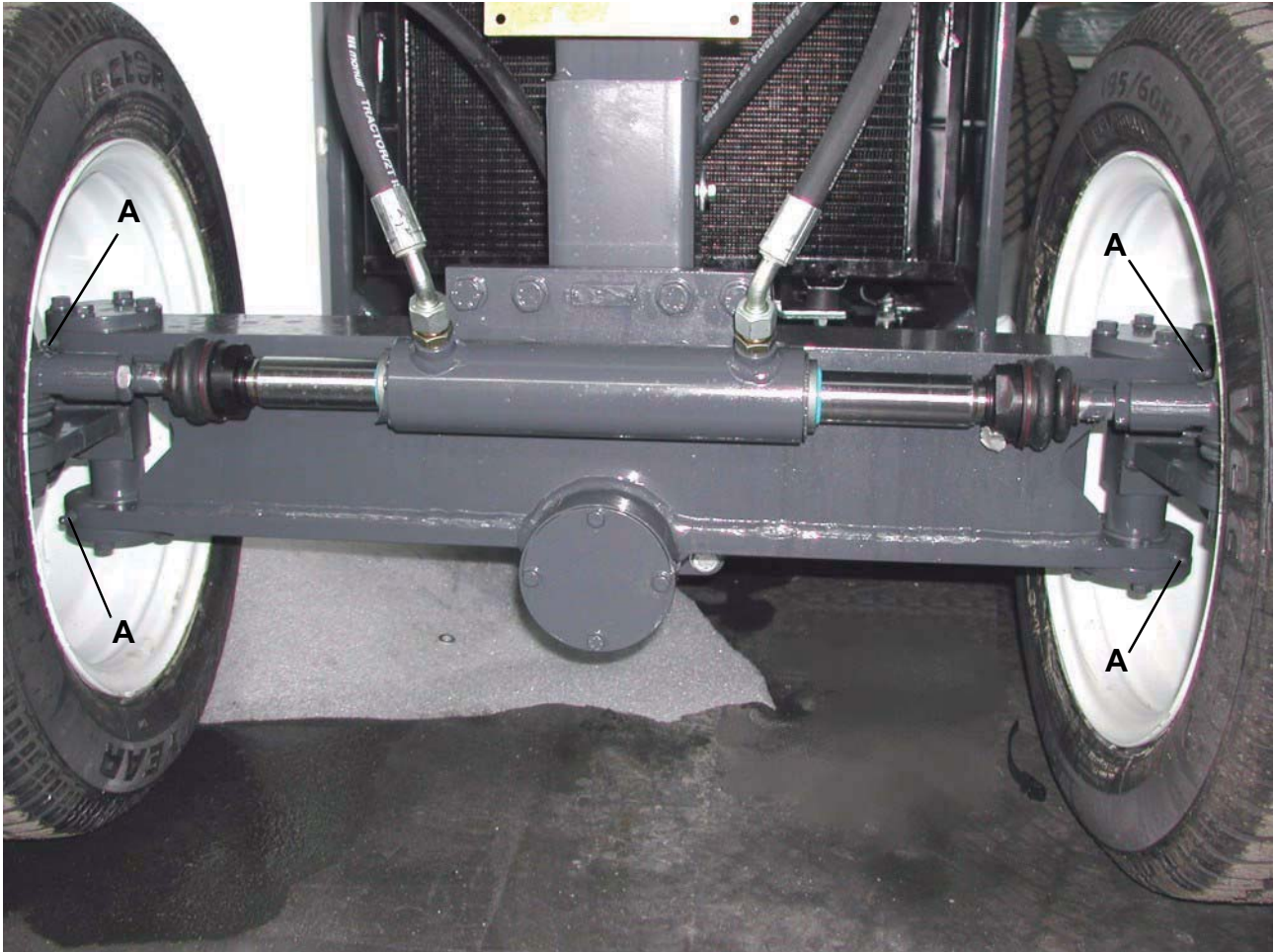

S300903

CHECK AND ADJUSTMENT OF SENSOR FOR ENGINE START-UP INHIBITION WHEN THE DRIVE PEDAL IS PRESSED

Check

1. Check that it is not possible to start the machine with the ignition key (76) when the drive pedal (56) is pressed.
If necessary, adjust the relevant sensor according to the following procedure.

Adjustment

1. Engage the parking brake with the lever (66).
2. Turn the ignition key (76) to OFF position and remove it.
3. Check that the surface (A) of the sensor (B) is flush with the surface (C) of the drive pedal.
If necessary, loosen the sensor mounting nut (D) and adjust the sensor position. When the adjustment is completed, tighten the nut (D).
4. Check that the distance between the sensor surface (A) and the bracket (E) is within 1.5 and 2.5 mm. When checking, move the drive pedal (F) towards the bracket (E) to cancel the drive pedal end play.
If necessary, loosen the nuts (G) and the nut (H), and adjust the position of the bracket (E). When the adjustment is completed, tighten the nuts (G) and (H).
5. Perform step 1 again.

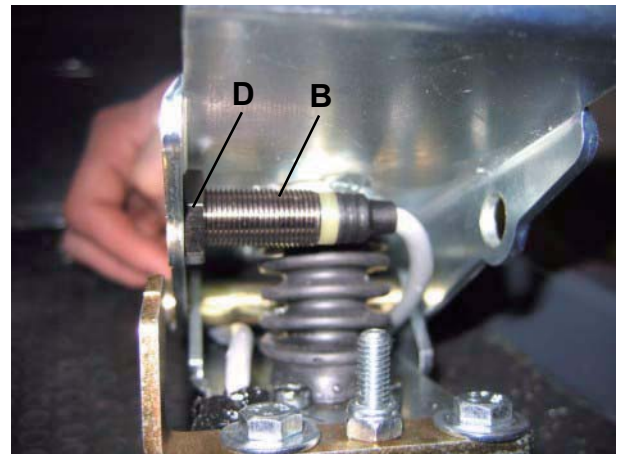
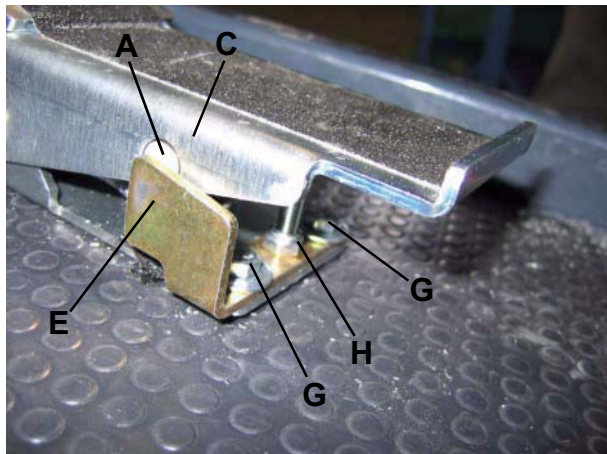
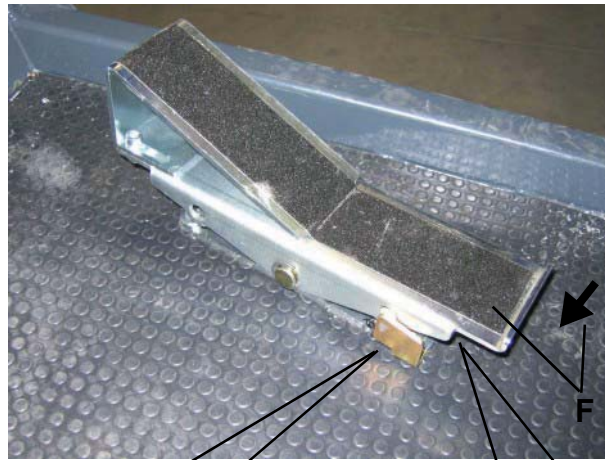

S301453

OTHER SYSTEMS

DISASSEMBLY/ASSEMBLY OF SENSOR FOR ENGINE START-UP INHIBITION WHEN THE DRIVE PEDAL IS PRESSED

Disassembly

1. Engage the parking brake with the lever (66).
2. Turn the ignition key (76) to OFF position and remove it.
3. Cut the cable clamp (A) under the right side of the cab.
4. Disconnect the connector (B) of the sensor for engine start-up inhibition (C).
5. Remove the four mounting screws (D) of the drive pedal (E).
6. Slightly lift the drive pedal (E) and remove the mounting nut (F) of the sensor (C).
7. Remove the sensor (C), the harness (G) and the connector.

Assembly

8. Assemble the components in the reverse order of disassembly.
9. Adjust the sensor for engine start-up inhibition (see the procedure in the relevant paragraph).

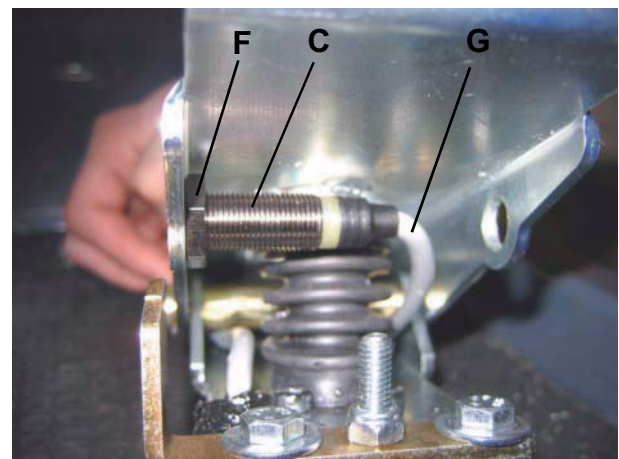
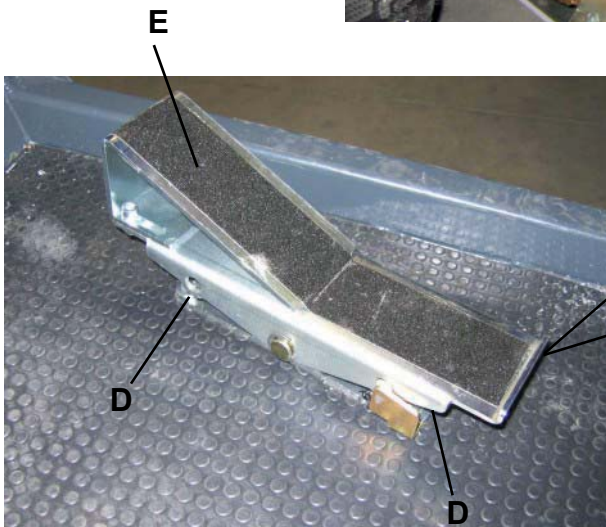
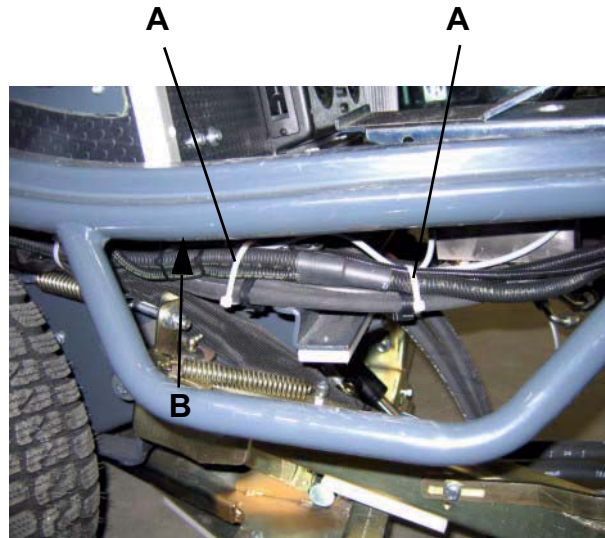

S301416

HYDRAULIC SYSTEM

DESCRIPTION

The hydraulic system consists of three independent circuits, supplied by one tank.

The first circuit is supplied by a variable delivery pump, activated by the diesel engine. This pump activates two drive system motors, which operate on the front wheels.

The forward and reverse drive speed is adjusted by the drive pedal, which is connected to the pump.

The second circuit is supplied by a gear pump, activated by the diesel engine. This pump activates the suction fan motor by means of the control valve assembly.

The third circuit is supplied by a gear pump with priority valve, activated by the diesel engine. This pumps, by means of the control valve assembly, performs the following functions:

- Side broom motor activation
- Hopper lifting and dumping
- Suction inlet lifting and moving
- Rear wheel control hydraulic cylinder activation (by means of the oil taken from the priority valve)

All circuits are protected by suction filters and safety valves.



NOTE

The hydraulic system hoses are DIN type.

COMPONENT LOCATION

50. Hydraulic system oil tank
51. Drain filter
52. Suction filter
53. Suction filter
54. Drive system pump
55. Diesel engine
56. Left drive system motor
57. Control valve assembly
58. Right drive system motor
59. Skirt cylinder
60. Hopper lifting cylinder
61. Hand pump
62. Right side broom motor
63. Left side broom motor
64. Hydraulic system oil cooler
65. Parachute valve
66. Suction inlet and broom lifting cylinder
67. Check valve
68. Power steering
69. Flow separator (priority valve)
70. Accessory and steering system pump
71. Suction fan pump
72. Control valve assembly
73. Solenoid valve
74. Suction fan motor
75. Power steering cylinder
76. Drive pedal assist
77. Oil filter
78. Drive system pump oil filter
79. High-pressure washing system pump (*)
80. Flow regulator (*)
81. Hydraulic system oil filler plug
82. Hydraulic system oil level indicator

(*) Optional for some countries.

HYDRAULIC SYSTEM

COMPONENT LOCATION (Continues)

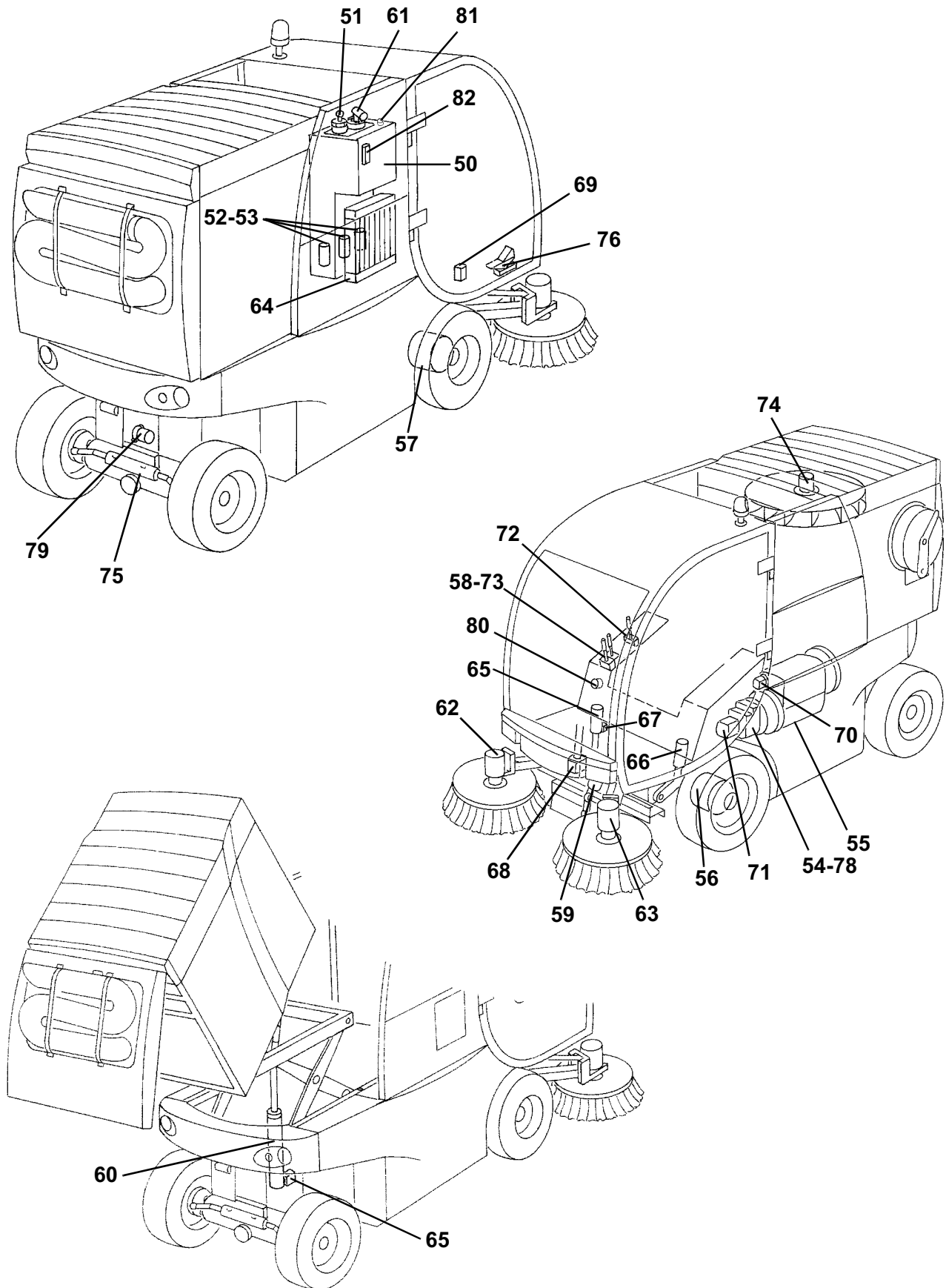

S301619

HYDRAULIC DIAGRAM

50. Hydraulic system oil tank
51. Drain filter
52. Suction filter
53. Suction filter
54. Drive system pump
55. Diesel engine
56. Left drive system motor (**)
57. Right drive system motor (**)
58. Control valve assembly
59. Skirt cylinder
60. Hopper lifting cylinder
61. Hand pump
62. Right side broom motor
63. Left side broom motor
64. Hydraulic system oil cooler
65. Parachute valve
66. Suction inlet and broom lifting cylinder
67. Check valve
68. Power steering
69. Flow separator (priority valve)
70. Accessory and steering system pump
71. Suction fan pump
72. Control valve assembly
73. Solenoid valve
74. Suction fan motor
75. Power steering cylinder
76. Drive pedal assist
77. Oil filter
78. Drive system pump oil filter
79. High-pressure washing system pump (*)
80. Flow regulator (*)
81. Breather/filler plug

(*) Optional for some countries.

(**) A version: 150 cc
B version, standard: 175 cc
C version: 200 cc

HYDRAULIC SYSTEM

HYDRAULIC DIAGRAM (Continues)

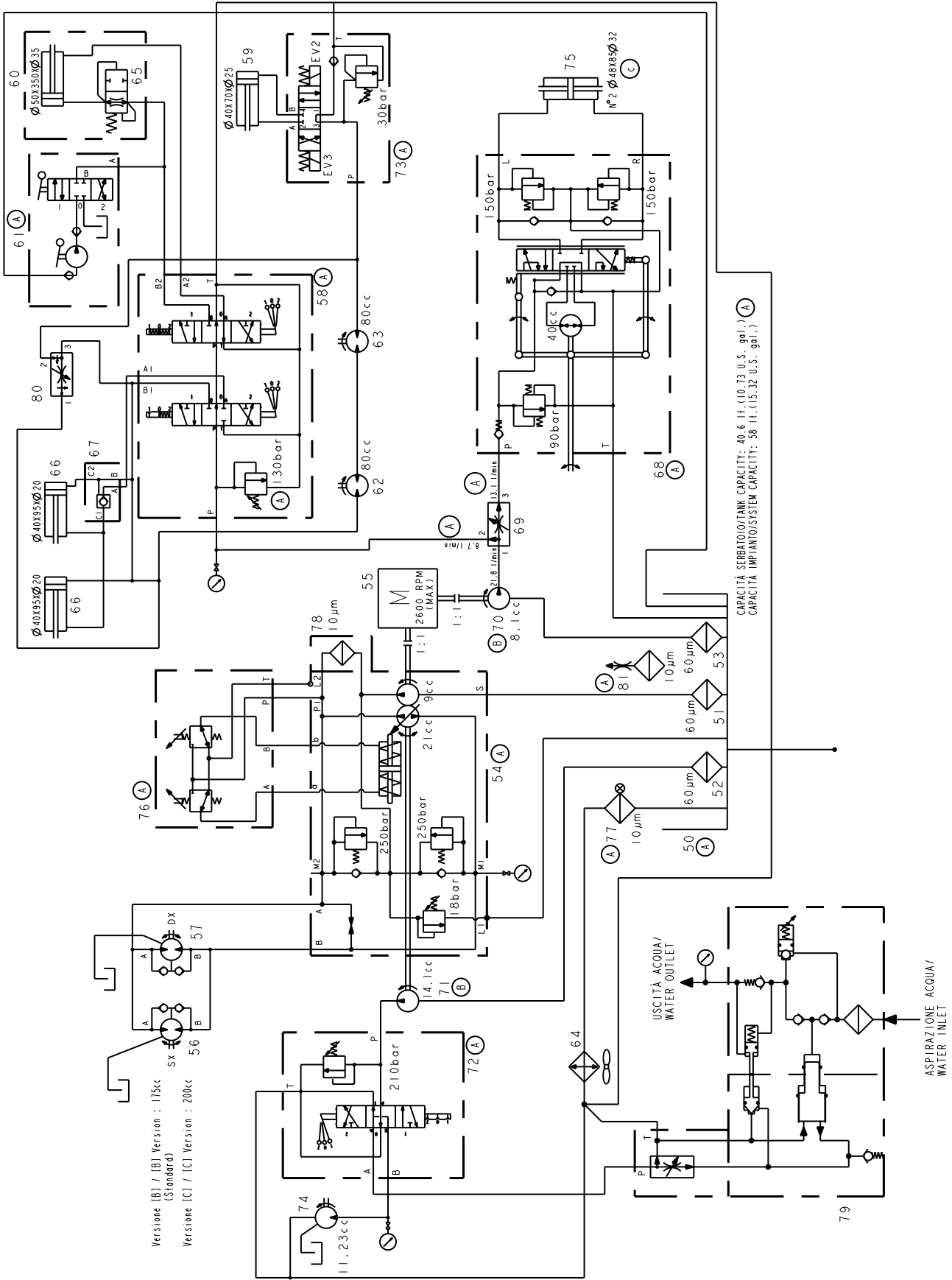

S301497

TROUBLESHOOTING

See the previous chapters related to the use of the hydraulic system.

HYDRAULIC SYSTEM

HYDRAULIC SYSTEM OIL LEVEL AND DRAIN FILTER EFFICIENCY CHECK

**CAUTION!**

This procedure must be performed with the hopper (3) fully retracted.

1. Engage the parking brake with the lever (66).
2. Start the diesel engine and run it at 1,500 rpm, according to the procedure shown in the User Manual.
3. Open the right lid (20) by releasing the fasteners (21) with the supplied key.
4. Check that the needle of the efficiency indicator (D) of the drain filter (C) is in the green area (E), otherwise the filter (C) must be replaced (see the procedure in the relevant paragraph).
5. Check that there are no oil leaks in the upper area (F) of the hydraulic system oil tank.
6. Turn the ignition key (76) to OFF position and remove it.
7. Using the indicator (A), check that the oil level in the tank is between the MIN and MAX marks.
8. If necessary, unscrew the plug (G) and top up. For the types of oil to be used, see Technical Data chapter.

**NOTE**

Top up by using the same type of oil that is in the tank.

9. Screw down the plug (G).
10. Close the right lid (20) by engaging the fasteners (21) with the supplied key.

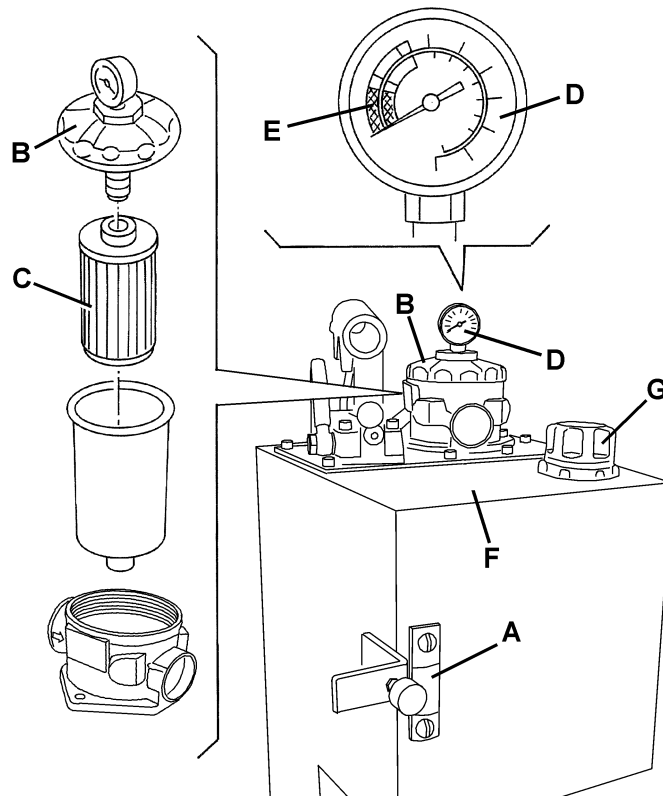

S301620

HYDRAULIC SYSTEM OIL CHANGE

**CAUTION!**

This procedure must be performed with the hopper (3) fully retracted (as shown in the figure).

1. Engage the parking brake with the lever (66).
2. Turn the ignition key (76) to OFF position and remove it.
3. Open the right lid (20) by releasing the fasteners (21) with the supplied key.
4. Empty the dust control system water tanks (7 and 16) according to the procedure shown in the relevant paragraph.
5. Remove the screw (44) and open the right tank (43).

**WARNING!**

Open the tanks (7 and 16) only if they are empty: each tank contains 120 kg of water approximately.

6. Remove the oil drain hose (E) under the tank, then unscrew the plug (A), drain the oil and collect it into an appropriate container.

**WARNING!**

Hydraulic system oil is highly corrosive, wear rubber gloves.

**CAUTION!**

The hydraulic system oil should be disposed of properly according to the environmental Laws in force.

7. Unscrew and remove the filler plug (B).
8. If necessary replace the drain filter (C) (see the procedure in the relevant paragraph).
9. Screw down the plug (A) and reinstall the oil drain hose (E) under the tank.
10. Pour oil in the tank (D) through the plug filler neck (B). For oil types and quantity, see the Technical Data chapter. Fill the tank until the oil level reaches the MAX mark of the indicator (F).
11. Screw down the filler plug (B).
12. Close the right lid (20) by engaging the fasteners (21) with the supplied key.
13. If necessary, fill the dust control system water tanks according to the procedure shown in the User Manual.

HYDRAULIC SYSTEM

HYDRAULIC SYSTEM OIL CHANGE (Continues)

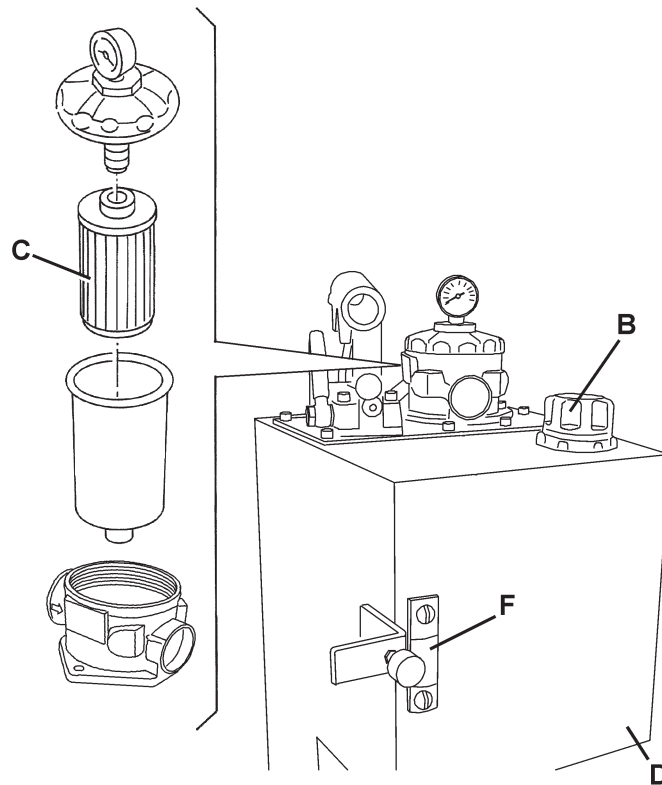
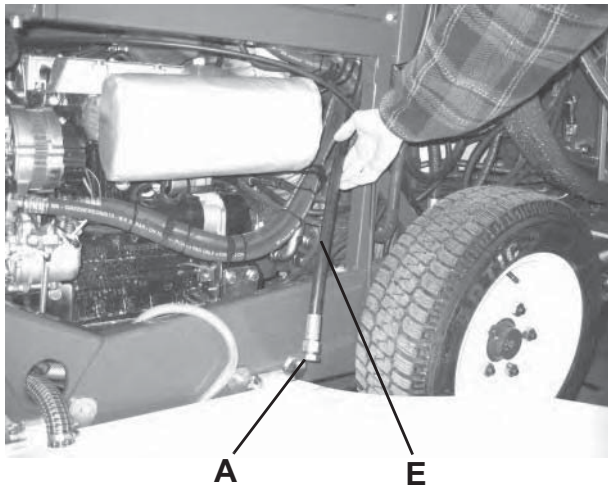

S301621

HYDRAULIC SYSTEM OIL SUCTION FILTER REPLACEMENT

**CAUTION!**

This procedure must be performed with the hopper (3) fully retracted.

1. If necessary, bleed the hydraulic system oil from the tank (see the procedure in the relevant paragraph).
2. Remove the screws (A), then remove the tank cover (B) without damaging the gasket (E).
3. Unscrew and remove the suction filters (C) inside the tank.

**WARNING!**

Hydraulic system oil is highly corrosive, wear rubber gloves.

**CAUTION!**

The hydraulic system oil and filters should be disposed of properly according to the environmental Laws in force.

4. Remove any debris and dirt from the tank.
5. Clean the tank upper perimeter edge (F) and the matching profile (D) of the cover (B).
6. Install the new filters (C) inside the tank.
7. Install the tank cover (B) and place the gasket (E) correctly; if necessary, replace it. Tighten the screws (A).
8. Pour the hydraulic system oil in the tank (see the procedure in the relevant paragraph).

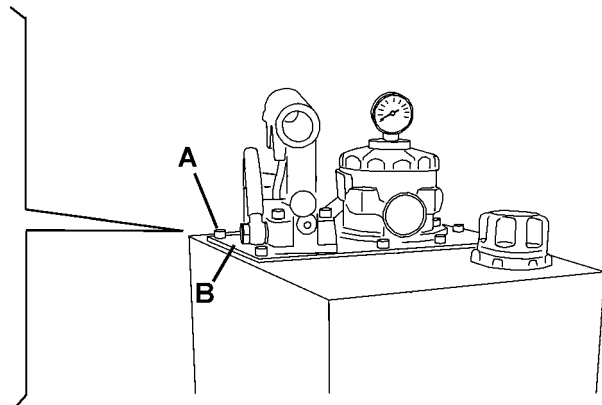
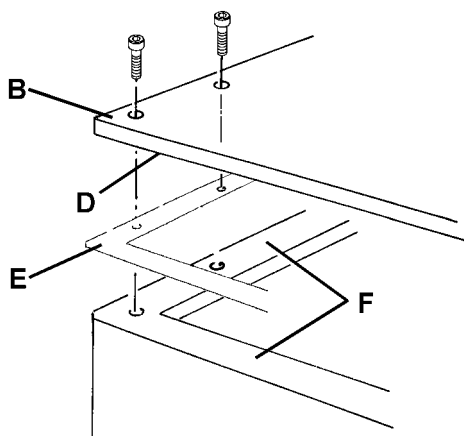
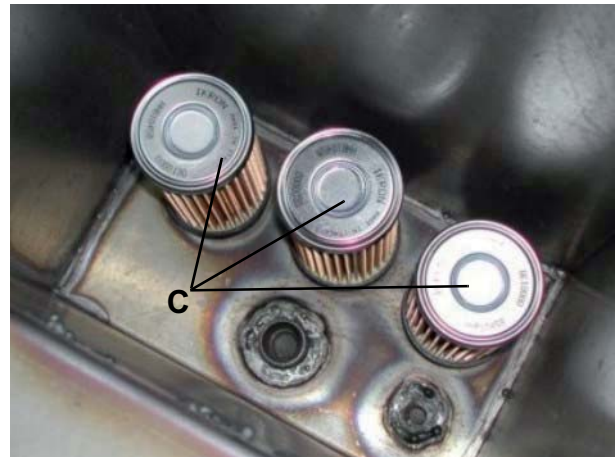

S301622

HYDRAULIC SYSTEM

HYDRAULIC SYSTEM OIL DRAIN FILTER REPLACEMENT

**CAUTION!**

This procedure must be performed with the hopper (3) fully retracted.

1. Engage the parking brake with the lever (66).
2. Turn the ignition key (76) to OFF position and remove it.
3. Open the right lid (20) by releasing the fasteners (21) with the supplied key.
4. Unscrew and remove the cover (A).

**WARNING!**

Hydraulic system oil is highly corrosive, wear rubber gloves.

**CAUTION!**

The hydraulic system oil and filters should be disposed of properly according to the environmental Laws in force.

5. Remove the drain filter (B) and replace it with a new one.
6. Install the cover (A).
7. Close the right lid (20) by engaging the fasteners (21) with the supplied key.

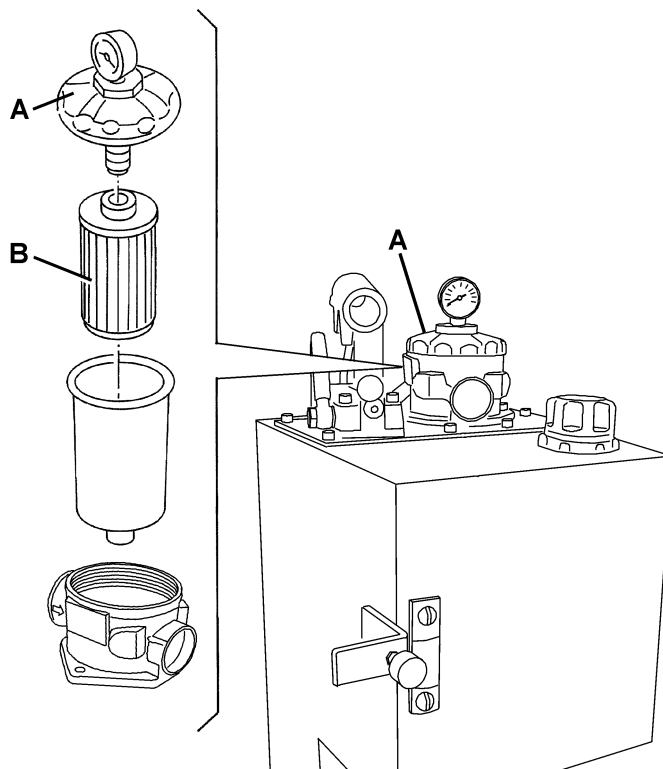

S301623

DRIVE SYSTEM PUMP OIL FILTER REPLACEMENT

1. Empty the hopper (3); if it contains a small quantity of waste, it is not necessary to dump it.
2. Drive the machine on a solid and level ground, then engage the parking brake with the lever (66).
3. Lift the hopper (3), according to the procedure shown in the User Manual.
4. Turn the ignition key (76) to OFF position and remove it.
5. Open the right lid (20) by releasing the fasteners (21) with the supplied key.
6. Remove the locking pins (28) from the housings (29) and place them into the holes (30).
7. Empty the dust control system water tanks (7 and 16) according to the procedure shown in the relevant paragraph.
8. Remove the screw (44) and open the right tank (43).

**WARNING!**

Open the tanks (7 and 16) only if they are empty: each tank contains 120 kg of water approximately.

9. Remove the screw (A) and the filter (B) behind the right front wheel.
If necessary, to reach the filter, remove the right front wheel according to the procedure shown in the relevant paragraph.

**WARNING!**

Hydraulic system oil is highly corrosive, wear rubber gloves.

**CAUTION!**

The hydraulic system oil and filters should be disposed of properly according to the environmental Laws in force.

10. Install a new filter (B) and fasten it with the screw (A).
11. Perform steps 3, 4, 5, 6 and 8 in the reverse order.
12. If necessary, fill the dust control system water tanks according to the procedure shown in the User Manual.

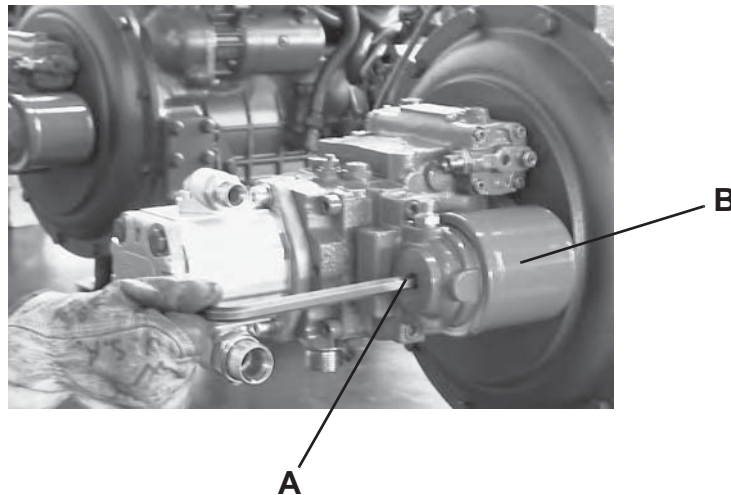

S300910

HYDRAULIC SYSTEM

HYDRAULIC SYSTEM OIL COOLER FIN CLEANING CHECK

**WARNING!**

Protect body parts (eyes, hair, hands, etc.) properly, when performing cleaning procedures using compressed air or water gun.

1. Empty the hopper (3); if it contains a small quantity of waste, it is not necessary to dump it.
2. Drive the machine on a solid and level ground, then engage the parking brake with the lever (66).
3. Lift the hopper (3), according to the procedure shown in the User Manual.
4. Turn the ignition key (76) to OFF position and remove it.
5. Open the right lid (20) by releasing the fasteners (21) with the supplied key.
6. Remove the locking pins (28) from the housings (29) and place them into the holes (30).
7. Clean the hydraulic system oil cooler fins (A) with compressed air (maximum 6 Bar). If necessary, point the compressed air in the opposite direction of the cooling air.
8. Inside the radiator (A), check that the fan (B) turns freely.
9. Perform steps 3 to 6 in the reverse order.

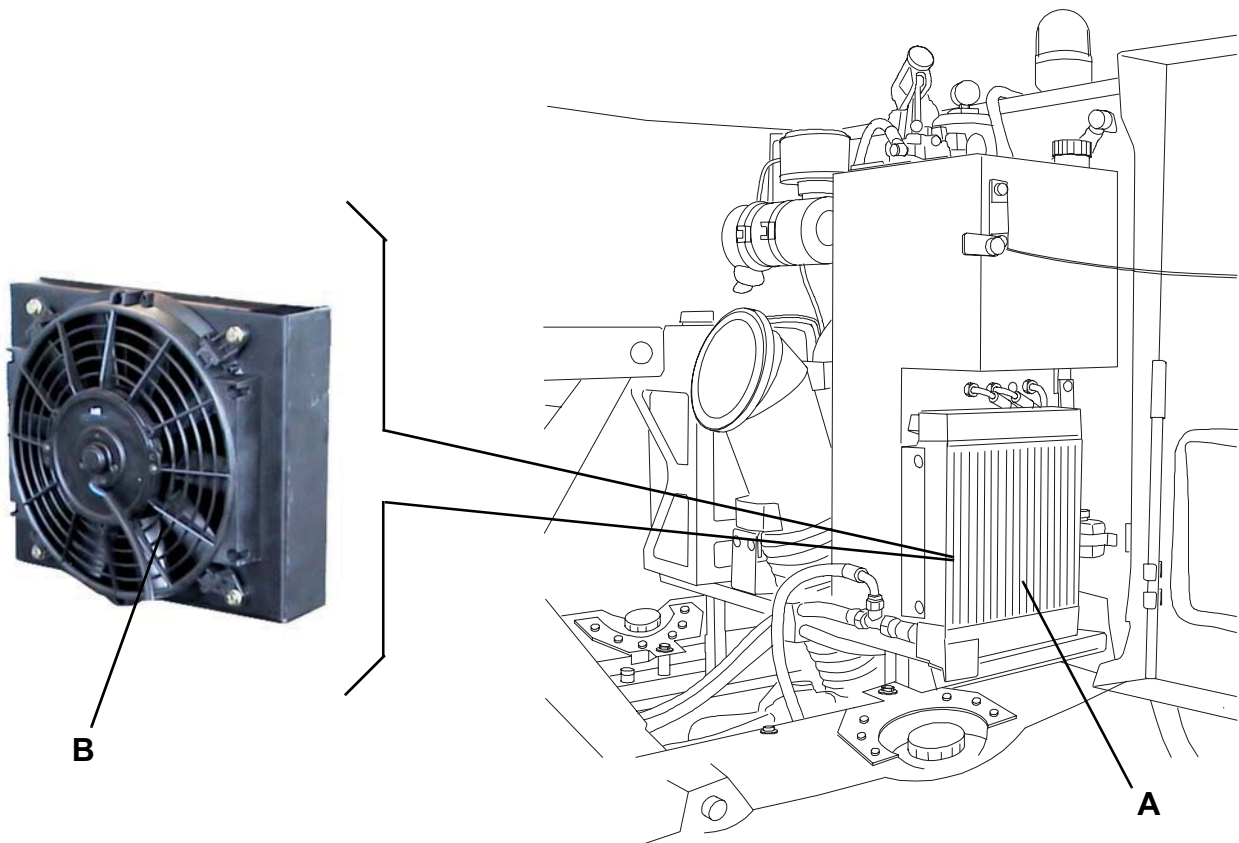

S301624

REAR WHEEL CONTROL HYDRAULIC CYLINDER DISASSEMBLY/ASSEMBLY

1. Drive the machine on a solid and level ground, then engage the parking brake with the lever (66).
2. Turn the ignition key (76) to OFF position and remove it.
3. Disconnect the hoses (A) from the rear wheel control hydraulic cylinder (B) and plug them immediately.
4. Unscrew the fasteners (C) fixing the cylinder to the steering tie rods.
5. Remove the screws (D), then remove the cylinder (B).
6. Install the cylinder performing steps from 3 to 5 in the reverse order.
7. Adjust the rear axle toe-in (see the procedure in the relevant paragraph).
8. Check the hydraulic system oil level (see the procedure in the relevant paragraph).

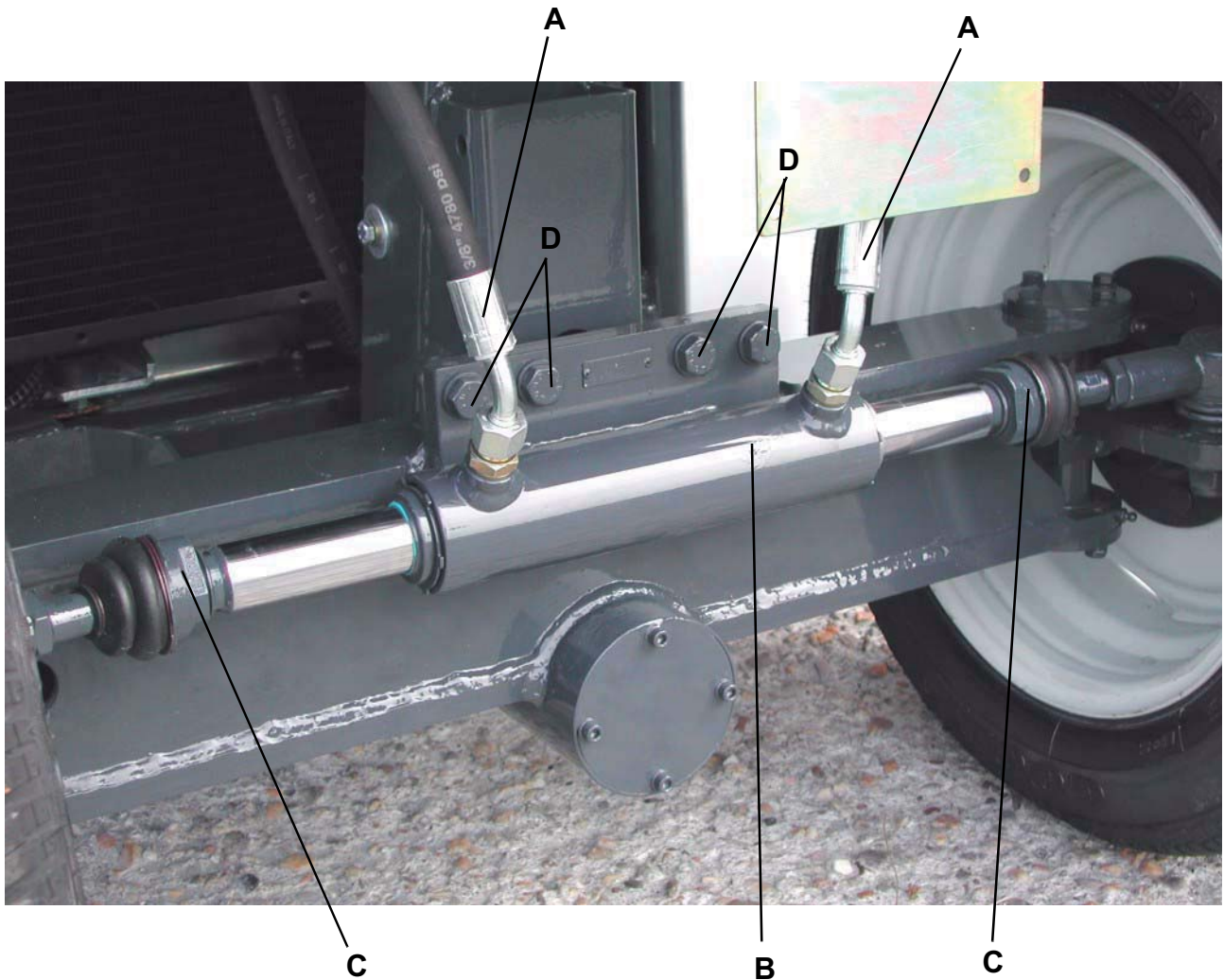

S300912

HYDRAULIC SYSTEM

HYDRAULIC CYLINDERS DISASSEMBLY/ASSEMBLY

**CAUTION!**

If necessary, remove the bonded sealing washers and replace them.

Disassembly/assembly of the following hydraulic cylinders:

- Suction inlet right cylinder (A)
- Suction inlet left cylinder (A)
- Skirt cylinder (C)

**CAUTION!**

This procedure must be performed with the hopper (3) fully retracted.

1. Engage the parking brake with the lever (66).
2. Bring the suction inlet in the most suitable position.
3. Turn the ignition key (76) to OFF position and remove it.
4. Disconnect the hoses from the hydraulic cylinder and plug them immediately.

**WARNING!**

Hydraulic system oil is highly corrosive, wear rubber gloves.

5. Disconnect and remove the hydraulic cylinder and, if necessary, support appropriately the components connected to the cylinder.
6. Perform steps 2 to 5 in the reverse order.
7. Start the machine and check that the hydraulic cylinder operates properly, then stop the machine, check the hydraulic system oil level and, if necessary, top up (as shown in the User Manual).

Disassembly/assembly of the following hydraulic cylinder:

- Hopper lifting cylinder (D)

1. Empty the hopper (3); if it contains a small quantity of waste, it is not necessary to dump it.
2. Drive the machine on a solid and level ground, then engage the parking brake with the lever (66).
3. Lift the hopper (3), according to the procedure shown in the User Manual.
4. Turn the ignition key (76) to OFF position and remove it.
5. Open the right lid (20) by releasing the fasteners (21) with the supplied key.
6. Remove the locking pins (28) from the housings (29) and place them into the holes (30).
7. Disconnect the hoses from the hydraulic cylinder and plug them immediately.

**WARNING!**

Hydraulic system oil is highly corrosive, wear rubber gloves.

8. Disconnect and remove the hydraulic cylinder and, if necessary, support appropriately the components connected to the cylinder.
9. Perform steps 3 to 8 in the reverse order.
10. Start the machine and check that the hydraulic cylinder operates properly, then stop the machine, check the hydraulic system oil level and, if necessary, top up (as shown in the User Manual).

HYDRAULIC CYLINDERS DISASSEMBLY/ASSEMBLY (Continues)

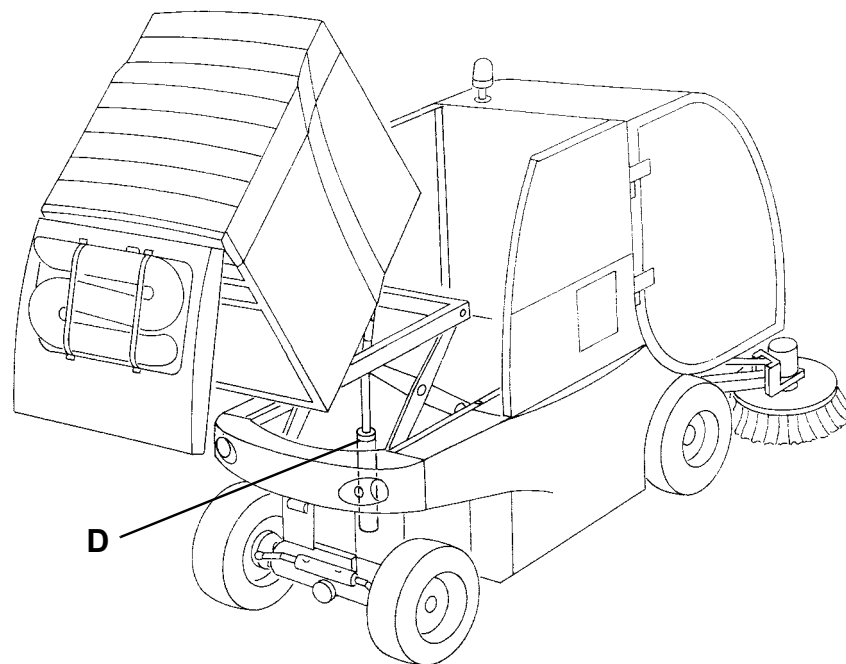
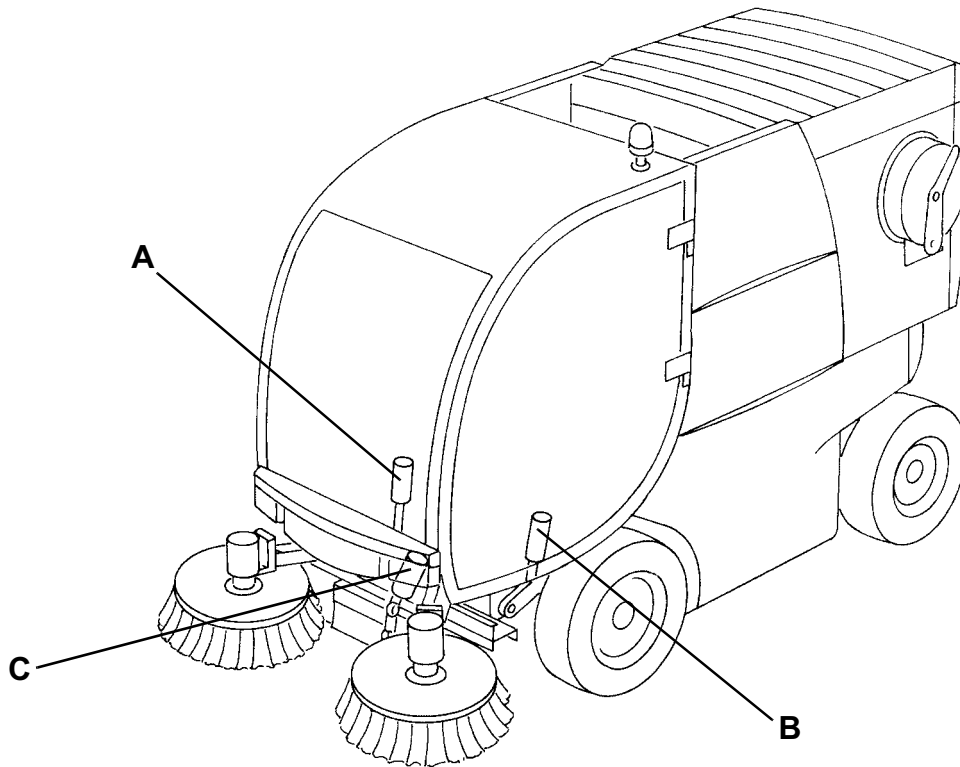

S300913

HYDRAULIC SYSTEM

SUCTION FAN CONTROL VALVE ASSEMBLY REMOVAL/INSTALLATION

CAUTION!

This procedure must be performed with the hopper (3) fully lowered.

CAUTION!

If necessary, remove the bonded sealing washers and replace them.

1. Remove the screws and the right panel (22) on the right side of the cab.
2. Disconnect all the hoses from the suction fan control valve assembly (A) and plug them immediately.

WARNING!

Hydraulic system oil is highly corrosive, wear rubber gloves.

3. Loosen the locknut (C) and remove the lever (B).
4. Remove the screws (D), then remove the control valve assembly (A).
5. If necessary, remove the fittings and the control valve assembly at the workbench.
6. Assemble the components in the reverse order of disassembly.
7. Check the hydraulic system oil level (see the procedure in the relevant paragraph).
8. Check the hydraulic system oil pressure at the suction fan pump (see the procedure in the relevant paragraph).

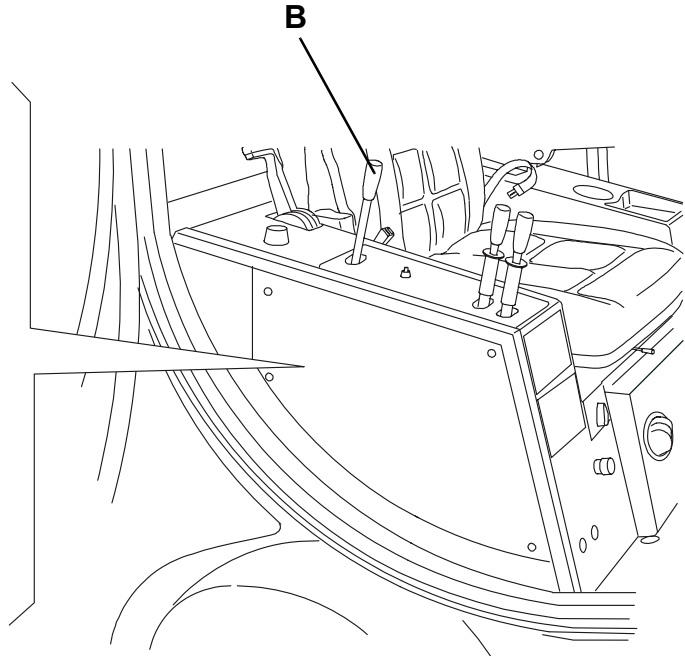
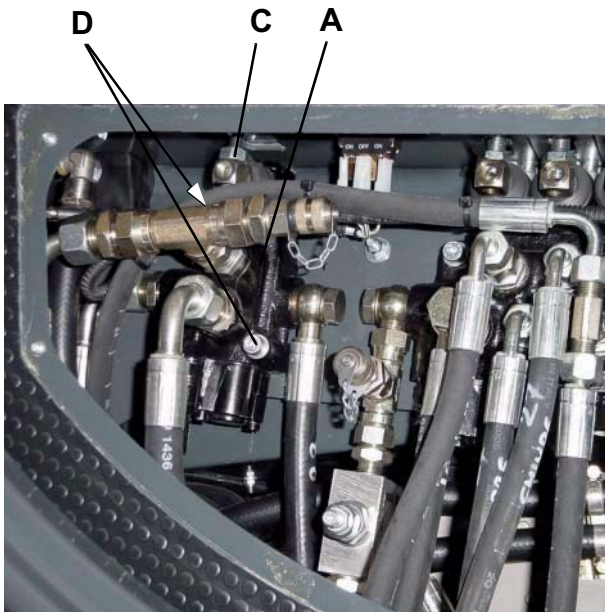

S301512

HYDRAULIC SYSTEM

ACCESSORY SYSTEM CONTROL VALVE ASSEMBLY REMOVAL/INSTALLATION

**CAUTION!**

This procedure must be performed with the hopper (3) fully lowered.

**CAUTION!**

If necessary, remove the bonded sealing washers and replace them.

1. If necessary, bleed the hydraulic system oil from the tank (see the procedure in the relevant paragraph).
2. Remove the screws and the right panel (22) on the right side of the cab.
3. Mark the position of the hoses connected to the accessory system control valve assembly (A) (for proper reassembly).
4. Disconnect all the hoses from the control valve assembly (A) and plug them immediately.

**WARNING!**

Hydraulic system oil is highly corrosive, wear rubber gloves.

5. Loosen the locknut (C) and remove the levers (B).
6. Remove the screws (D), then remove the control valve assembly (A).
7. If necessary, remove the fittings and the control valve assembly at the workbench.
8. Assemble the components in the reverse order of disassembly.
9. Pour oil in the tank (see the procedure in the relevant paragraph) until the level reaches the MIN mark of the indicator.
10. Start the machine, use the drive system and lift/lower the hopper a few times. Check that controls (60), (62) and (63) operate properly. Then stop the machine, check the hydraulic system oil level and, if necessary, top up (as shown in the User Manual).
11. Check the hydraulic system oil pressure at the accessory and steering system pump (see the procedure in the relevant paragraph).

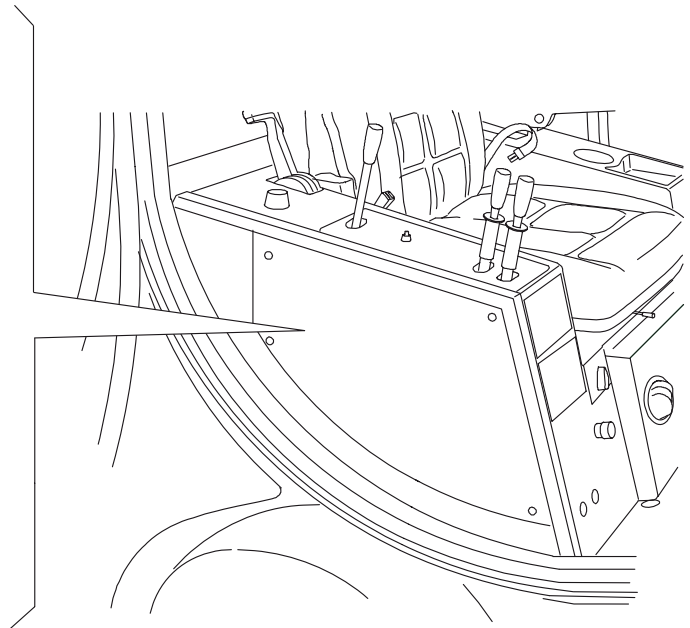
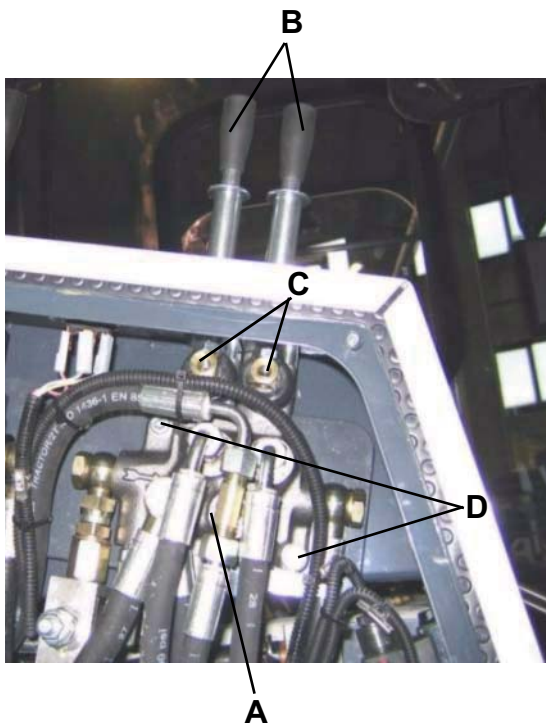

S301513

HYDRAULIC SYSTEM

ACCESSORY AND STEERING SYSTEM PUMP DISASSEMBLY/ASSEMBLY (LDW 1603/B2 engine)

**CAUTION!**

This procedure must be performed with the hopper (3) fully retracted (as shown in the figure).

**CAUTION!**

If necessary, remove the bonded sealing washers and replace them.

1. Empty the hopper (3); if it contains a small quantity of waste, it is not necessary to dump it.
2. Drive the machine on a solid and level ground, then engage the parking brake with the lever (66).
3. Lift the hopper (3), according to the procedure shown in the User Manual.
4. Turn the ignition key (76) to OFF position and remove it.
5. Open the left lid (18) by releasing the fasteners (19) with the supplied key.
6. Remove the locking pins (28) from the housings (29) and place them into the holes (30).
7. Empty the dust control system water tanks (7 and 16) according to the procedure shown in the relevant paragraph.
8. Remove the screw (44) and open the right tank (43).

**WARNING!**

Open the tanks (7 and 16) only if they are empty: each tank contains 120 kg of water approximately.

9. Remove the retaining clamps (C) of the exhaust manifold (D), then move the exhaust manifold.
10. Mark the position of the hoses connected to the fittings (E) of the accessory pump (F) (for proper reassembly).
11. Disconnect the hoses from the fittings (E) of the accessory pump (F) and plug them immediately. Collect the hydraulic system oil that comes out of the hoses before plugging them.

**WARNING!**

Hydraulic system oil is highly corrosive, wear rubber gloves.

12. Remove the screws (G), then remove the accessory pump (F) by disengaging the connecting joint.
13. If necessary, remove the accessory pump fittings at the workbench.
14. Assemble the components in the reverse order of disassembly.
15. Start the machine, lift/lower the hopper and activate the brooms a few times, then stop the machine, check the hydraulic system oil level and, if necessary, top up (as shown in the User Manual).
16. Check the hydraulic system oil pressure at the accessory and steering system pump (see the procedure in the relevant paragraph).
17. If necessary, fill the dust control system water tanks according to the procedure shown in the User Manual.

HYDRAULIC SYSTEM

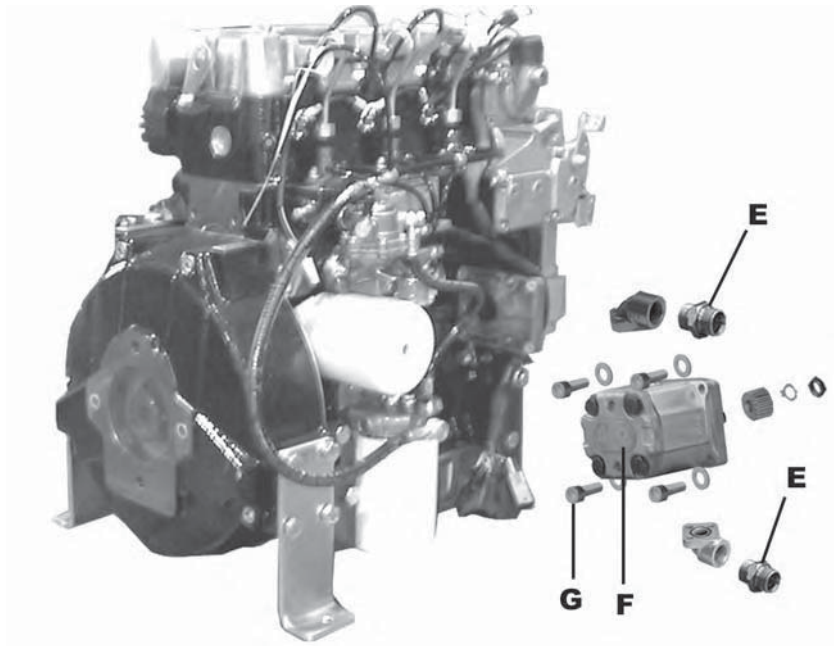
ACCESSORY AND STEERING SYSTEM PUMP DISASSEMBLY/ASSEMBLY (LDW 1603/B2 engine)
(Continues)

S300916

HYDRAULIC SYSTEM

ACCESSORY AND STEERING SYSTEM PUMP DISASSEMBLY/ASSEMBLY (LDW 1603/B2 engine) (Continues)

**CAUTION!**

This procedure must be performed with the hopper (3) fully retracted (as shown in the figure).

**CAUTION!**

If necessary, remove the bonded sealing washers and replace them.

1. Empty the hopper (3); if it contains a small quantity of waste, it is not necessary to dump it.
2. Drive the machine on a solid and level ground, then engage the parking brake with the lever (66).
3. Lift the hopper (3), according to the procedure shown in the User Manual.
4. Turn the ignition key (76) to OFF position and remove it.
5. Open the left lid (18) by releasing the fasteners (19) with the supplied key.
6. Remove the locking pins (28) from the housings (29) and place them into the holes (30).
7. Empty the dust control system water tanks (7 and 16) according to the procedure shown in the relevant paragraph.
8. Remove the screw (42) and open the left tank (41).

**WARNING!**

Open the tanks (7 and 16) only if they are empty: each tank contains 120 kg of water approximately.

9. Mark the position of the hoses connected to the fittings (E) of the accessory pump (F) (for proper reassembly).
10. Disconnect the hoses from the fittings (E) of the accessory pump (F) and plug them immediately. Collect the hydraulic system oil that comes out of the hoses before plugging them.

**WARNING!**

Hydraulic system oil is highly corrosive, wear rubber gloves.

11. Remove the screws (G), then remove the accessory pump (F) by disengaging the connecting joint.
12. If necessary, remove the accessory pump fittings at the workbench.
13. Assemble the components in the reverse order of disassembly.
14. Start the machine, lift/lower the hopper and activate the brooms a few times, then stop the machine, check the hydraulic system oil level and, if necessary, top up (as shown in the User Manual).
15. Check the hydraulic system oil pressure at the accessory and steering system pump (see the procedure in the relevant paragraph).
16. If necessary, fill the dust control system water tanks according to the procedure shown in the User Manual.

HYDRAULIC SYSTEM

ACCESSORY AND STEERING SYSTEM PUMP DISASSEMBLY/ASSEMBLY (LDW 1603/B2 engine)
(Continues)

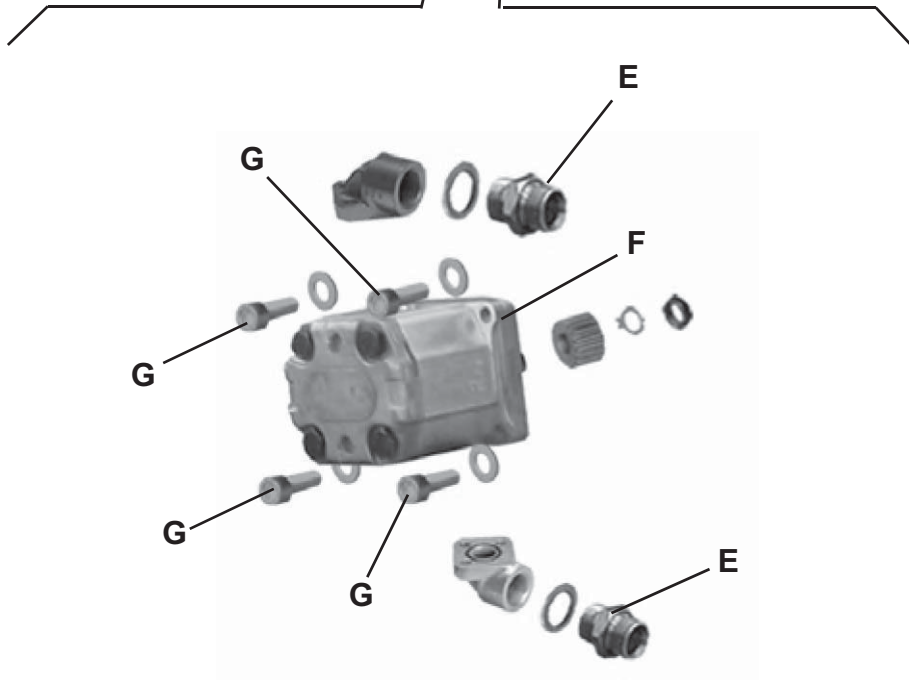
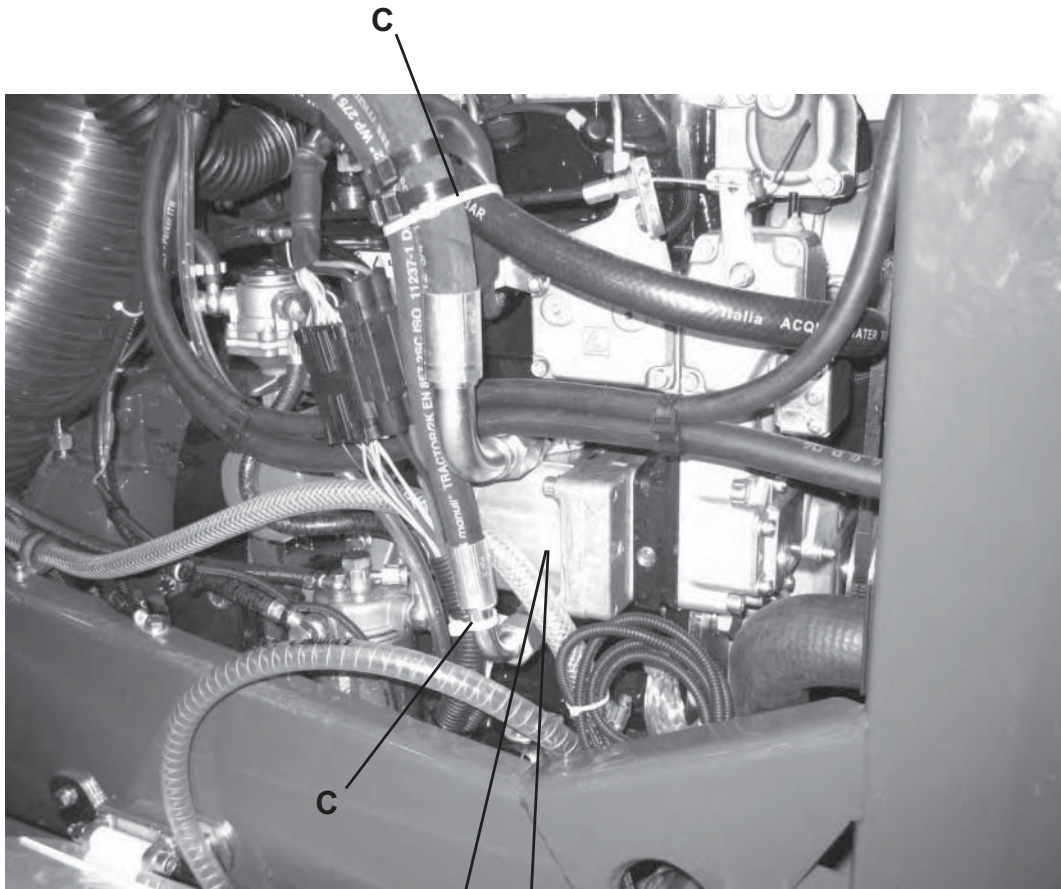

S301423

HYDRAULIC SYSTEM

SUCTION FAN PUMP DISASSEMBLY/ASSEMBLY

**CAUTION!**

This procedure must be performed with the hopper (3) fully retracted.

**CAUTION!**

If necessary, remove the bonded sealing washers and replace them.

1. Remove the suction inlet (see the procedure in the relevant paragraph).
2. Mark the position of the hoses connected to the fittings (A) of the suction fan pump (B) (for proper reassembly).
3. Disconnect the hoses from the fittings (A) of the suction fan pump (B) and plug them immediately. Collect the hydraulic system oil that comes out of the hoses before plugging them.

**WARNING!**

Hydraulic system oil is highly corrosive, wear rubber gloves.

4. Remove the screws (C), then remove the suction fan pump (B) with the joint (D) and the relevant fasteners.
5. If necessary, remove the accessory pump joint (D) and fittings at the workbench.
6. Assemble the components in the reverse order of disassembly.
7. Start the machine, lift/low the hopper and activate the suction fan a few times, then stop the machine, check the hydraulic system oil level and, if necessary, top up (as shown in the User Manual).
8. Check the hydraulic system oil pressure at the suction fan pump (see the procedure in the relevant paragraph).

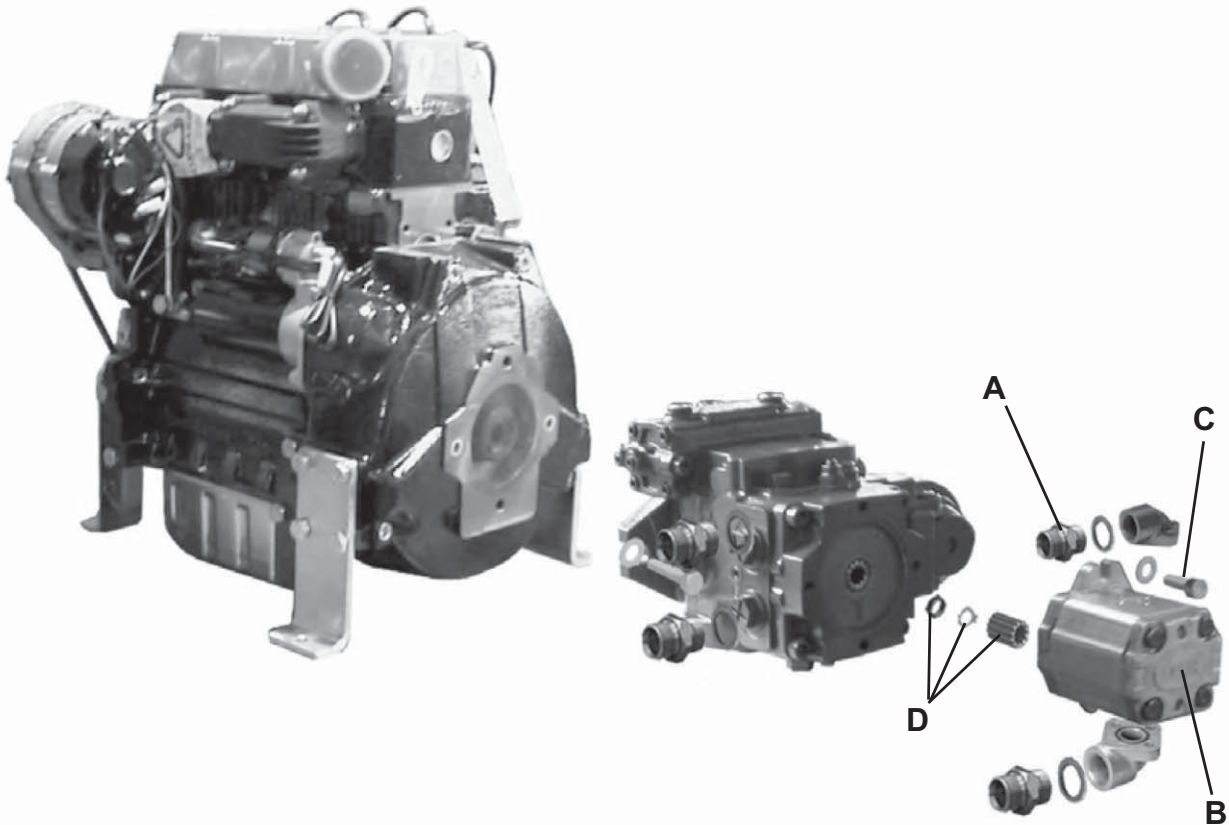

S301424

DRIVE SYSTEM PUMP DISASSEMBLY/ASSEMBLY

**CAUTION!**

This procedure must be performed with the hopper (3) fully retracted.

**CAUTION!**

If necessary, remove the bonded sealing washers and replace them.

1. Remove the suction inlet (see the procedure in the relevant paragraph).
2. Mark the position of the hoses connected to the fittings (A) of the drive system pump (B) and of the suction fan pump (C) (for proper reassembly).
3. Disconnect the hoses from the fittings (A) of the drive system pump (B) and of the suction fan pump (C), then plug them immediately. Collect the hydraulic system oil that comes out of the hoses before plugging them.

**WARNING!**

Hydraulic system oil is highly corrosive, wear rubber gloves.

4. Remove the screws (E), then remove the pumps (B) and (C) with the relevant joints.
5. If necessary, remove the drive system pump fittings at the workbench.
If necessary, remove the screws (E), then remove the suction fan pump (C) with the joint (F) and the relevant fasteners.
6. Assemble the components in the reverse order of disassembly.
7. Start the machine, use the drive system and activate the suction fan, then stop the machine, check the hydraulic system oil level and, if necessary, top up (as shown in the User Manual).
8. Check the hydraulic system oil pressure at the drive system pump (see the procedure in the relevant paragraph).

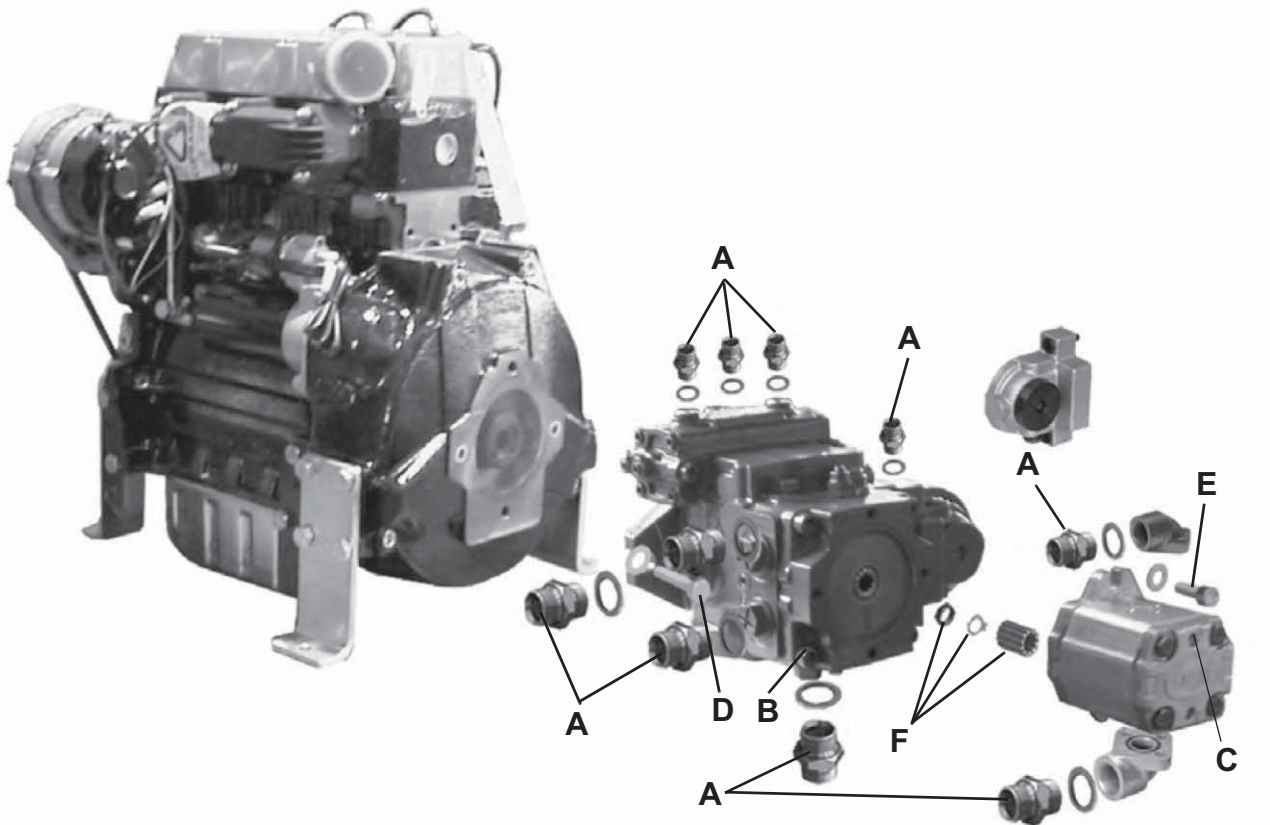

S301425

HYDRAULIC SYSTEM

HYDRAULIC SYSTEM OIL PRESSURE CHECK AT THE SUCTION FAN PUMP

**NOTE**

This check is necessary in case of malfunction of the suction fan.

Preliminary operations

1. Drive the machine on a solid and level ground, then engage the parking brake with the lever (66).
2. Turn the ignition key (76) to OFF position and remove it.
3. Remove the screws and the right panel (22) on the right side of the cab.
4. Connect a pressure gauge (E), with a minimum scale of 250 Bar equipped with the extension, to the pressure intake (C).
5. Measure the suction fan pump pressure according to the following procedure.

Pressure measurement

6. Start the machine and run the engine at maximum speed (as shown in the User Manual). In this condition, turn the lever (F) to "OPT" position and check that the pressure measured by the pressure gauge (E) is 220 Bar approximately.
 - If the pressure is normal, disengage the lever (F) and turn off the machine.
 - If the pressure is higher or lower, it can be adjusted according to the following procedure, while keeping the machine accelerated and the lever (F) engaged.

Pressure adjustment

7. Unscrew the cap (G).
8. Loosen the locknut (H) and slightly turn the internal threaded dowel (I) to adjust the pressure. If the pressure cannot be adjusted to normal values, probably the pump needs to be replaced (see the procedure in the relevant paragraph).
9. Disengage the lever (F) and turn off the machine.
10. Tighten the locknut (H) and screw down the cap (G).

Reset

11. Perform steps 3 and 4 in the reverse order.

HYDRAULIC SYSTEM

HYDRAULIC SYSTEM OIL PRESSURE CHECK AT THE SUCTION FAN PUMP (Continues)

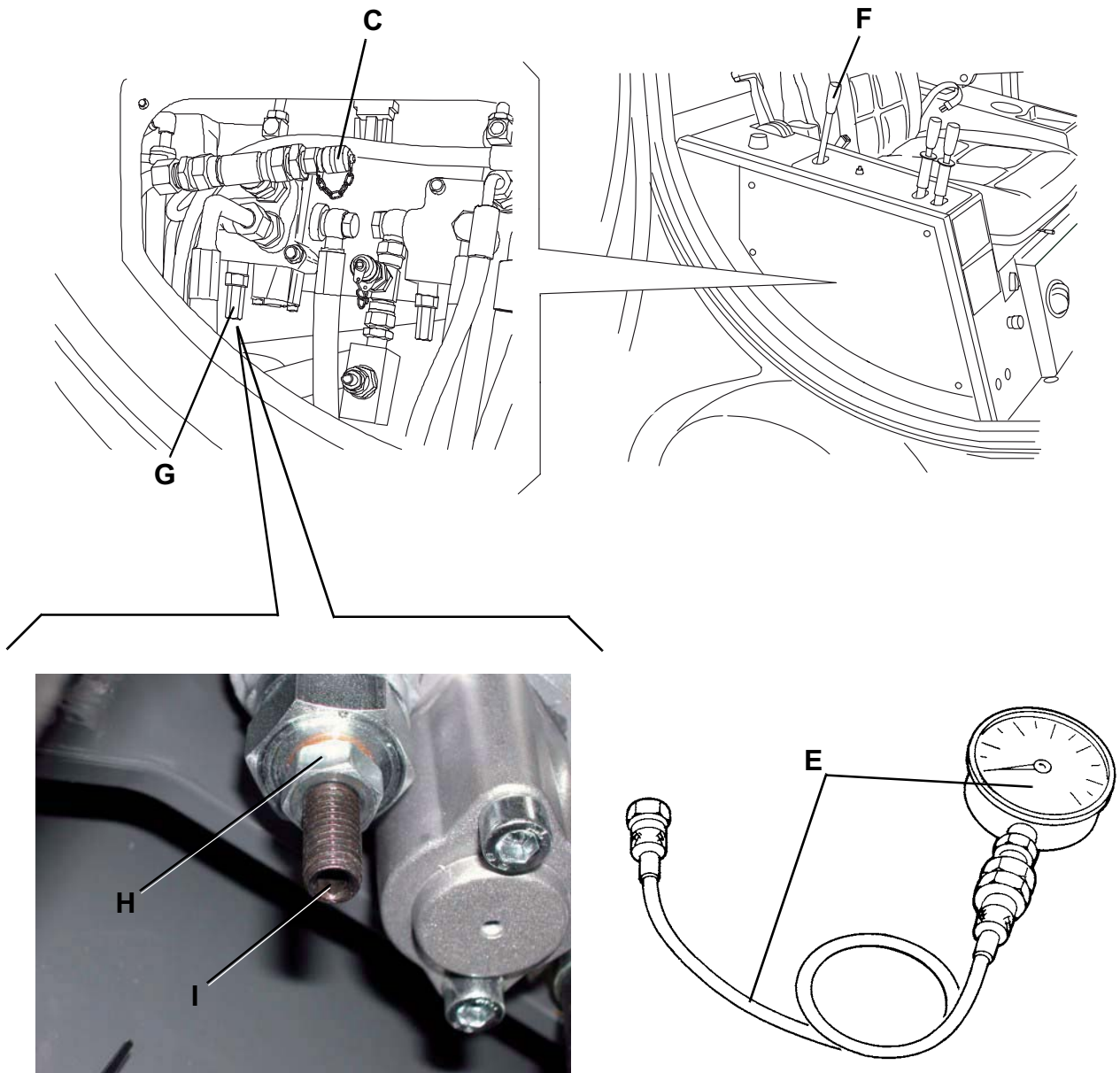

S301500

HYDRAULIC SYSTEM

HYDRAULIC SYSTEM OIL PRESSURE CHECK AT THE ACCESSORY AND STEERING SYSTEM PUMP

**NOTE**

This check is necessary in case of malfunction of the accessory system and steering system.

Preliminary operations

1. Empty the hopper (3); if it contains a small quantity of waste, it is not necessary to dump it.
2. Drive the machine on a solid and level ground, then engage the parking brake with the lever (66).
3. Turn the ignition key (76) to OFF position and remove it.
4. Remove the screws and the right panel (22) on the right side of the cab.
5. Connect a pressure gauge (E) with a minimum scale of 150 Bar equipped with the extension.
6. Measure the accessory and steering system pump pressure according to the following procedure.

Pressure measurement

7. Start the machine and run the engine at maximum speed (as shown in the User Manual). In this condition, engage the lever (F) to lift the hopper and check that the pressure measured by the pressure gauge (E) is 120 Bar approximately.
 - If the pressure is normal, disengage the lever (F) and turn off the machine.
 - If the pressure is higher or lower, it can be adjusted according to the following procedure, while keeping the machine accelerated and the lever (F) engaged.

Pressure adjustment

8. Unscrew the cap (G).
9. Loosen the locknut (H) and slightly turn the internal threaded dowel (I) to adjust the pressure. If the pressure cannot be adjusted to normal values, probably the pump needs to be replaced (see the procedure in the relevant paragraph).
10. Disengage the lever (F) and turn off the machine.
11. Tighten the locknut (H) and screw down the cap (G).

Reset

12. Perform steps 4 and 5 in the reverse order.

HYDRAULIC SYSTEM

HYDRAULIC SYSTEM OIL PRESSURE CHECK AT THE ACCESSORY AND STEERING SYSTEM PUMP (Continues)

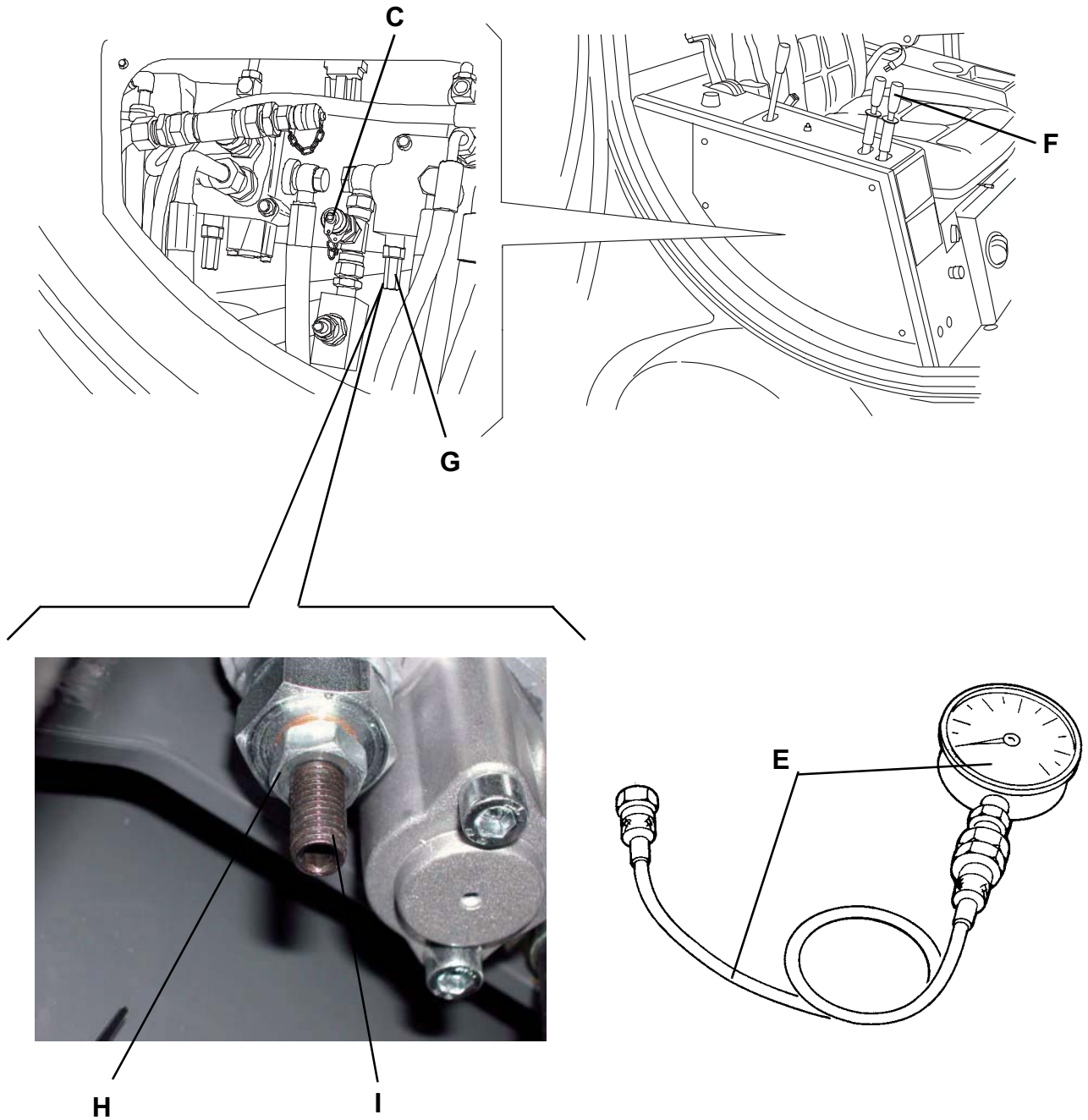

S301501

HYDRAULIC SYSTEM

HYDRAULIC SYSTEM OIL PRESSURE CHECK ON DRIVE SYSTEM PUMP

**NOTE**

This check is necessary in case of malfunction of the drive system.

Preliminary operations

1. Empty the hopper (3). If it contains a small quantity of waste, it is not necessary to dump it.
2. Drive the machine on a solid and level ground and engage the parking brake with the lever (66). To perform the inspection, indicated in the next step 9, in a safe condition, the ground opposite the machine have to be free from obstruction and levelled.
3. Turn the ignition key (76) to OFF position and remove it.
4. Remove the screw (42), open the left water tank (7) and disconnect the fastener, then fully open the tank.

**WARNING!**

Open the left tank (41) only when it is empty: each tank contains 120 kg of water approximately.

5. Connect a pressure gauge (E), with a minimum scale of 300 Bar equipped with the extension, to the pressure intake (B) of the drive system pump.
6. Measure the drive system pump pressure according to the following procedure.

Pressure measurement

7. Start the machine and run the engine at maximum speed (as shown in the User Manual).
8. Fully engage the parking brake with the lever (66).

**WARNING!**

To perform the inspection, indicated in the next step 9, in a safe condition, keep the personnel away from the front of the machine and remove any obstructions.

9. Press and hold the brake pedal (57), then fully press the drive pedal (56) (**if the machine moves, release the drive pedal (56), then try again by firmly pressing the brake pedal (57)**). Check that the pressure on the pressure gauge (A) is within 200 and 250 Bar.
 - If the pressure is normal, release the drive pedal (56) and turn off the machine.
 - If the pressure is lower than specified, check if the fault is related to the drive system pump or to the drive pedal assist.

Reset

10. Perform steps 4 and 5 in the reverse order.

HYDRAULIC SYSTEM

HYDRAULIC SYSTEM OIL PRESSURE CHECK ON DRIVE SYSTEM PUMP (Continues)

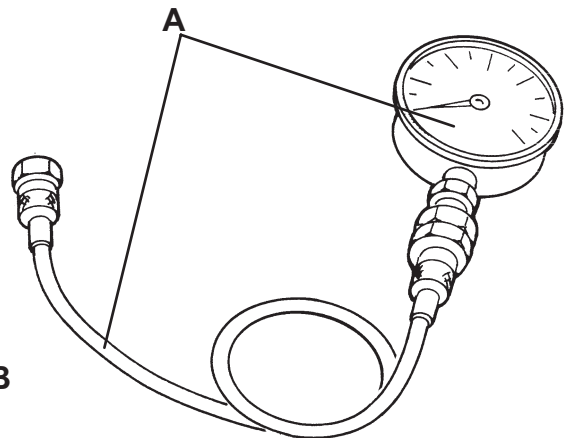
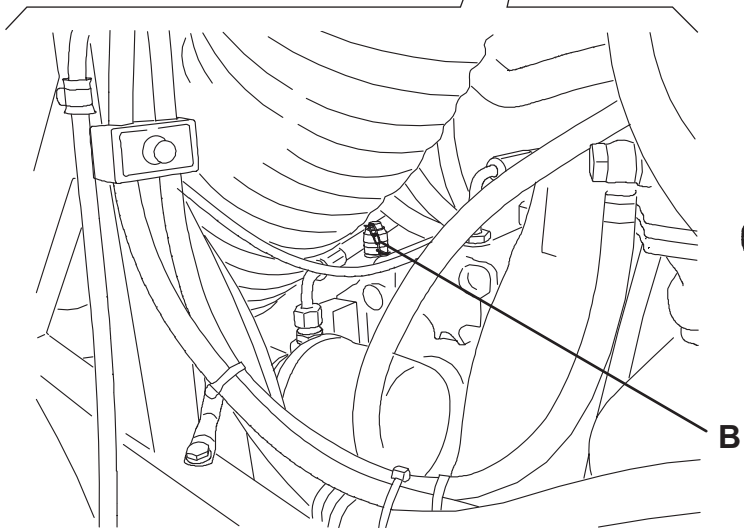
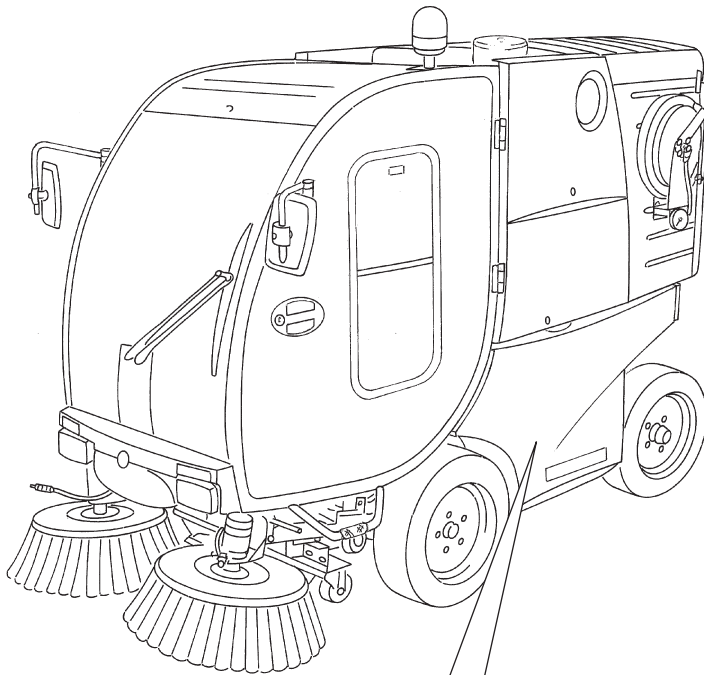

S301502

HYDRAULIC SYSTEM

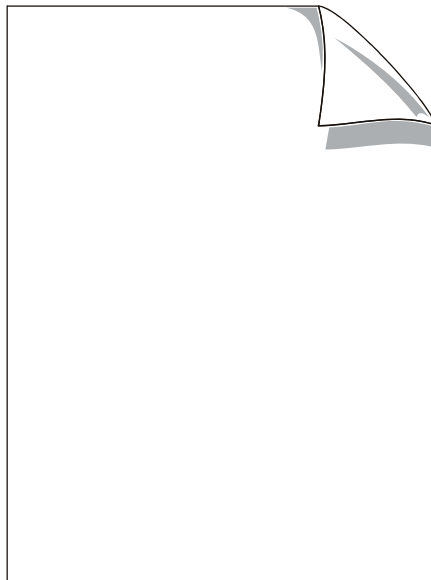

ELECTRICAL SYSTEM

DESCRIPTION

The electrical system is power-supplied from the alternator, which is activated by the diesel engine.

The battery is 12 V.

Circuits are protected by lamellar fuses, which are located into appropriate fuse boxes.

COMPONENT LOCATION



NOTE

The abbreviation written before the component name refers to the wiring diagram (see the following pages).

A	Alternator	L3	Right front turn signal
AA	Horn	L4	Left rear turn signal
AS	Cigarette lighter	L5	Left brake light
B	12 V battery	L6	Right brake light
B1	Engine coolant temperature bulb	L7	Left front running light
B2	Engine oil bulb	L8	Right rear running light
B3	Engine coolant warning light bulb	L9	Right front running light
B4	Parking brake microswitch	L10	Left rear running light
B5	Lifted hopper microswitch	L11	Left low beam
B6	Brake light microswitch	L12	Right low beam
B7	Hydraulic system oil cooler fan bulb	L13	Left high beam
B8	Reverse gear sensor	L14	Right high beam
BX	Engine start safety sensor	L15	Flashing light
C1	Ignition switch	L16	Licence plate light
C2	Combination switch	M1	Starter
C3	Warning buzzer/parking brake buzzer	M2	Hydraulic system oil cooler fan motor
C4	Reverse gear buzzer	M3	Windscreen wiper motor
C5	Hour counter/revolution counter/water temperature indicator	M4	Dust control system water pump (normal)
C6	Climate control system compressor	M5	Cab blower motor
D1	Diode	M6	Climate control system blower motor
D2	Diode	M7	Windscreen washer motor with tank
EV1	Fuel solenoid valve	M8	Hopper lid opening/closing electric jack motor
EV2	Skirt solenoid valve	P	Climate control system pressure switch
EV3	Skirt solenoid valve	R1	Engine glow plug control unit relay
F1A	Hydraulic system oil cooler fan/skirt solenoid valve fuse (20 A)	R2	General relay
F2A	Fuel solenoid valve fuse (10 A)	R3	Reverse gear buzzer relay
F3A	Cab blower/flashing light/windscreen wiper fuse (15 A)	R4	Turn signal intermittence relay
F4A	Dust control system water pump fuse (10 A) Dust control system water pump/climate control system (optional) fuse (20 A)	R5	Water pump relay
F5A	Reverse gear buzzer fuse (10 A)	R6	Climate control system compressor relay (*)
F6A	Warning lights/glow plug control unit fuse (10 A)	R7	Climate control system condenser fan relay (*)
F7A	Electric jack warning light fuse (10 A)	RS	Cab blower resistance
F8A	Hopper lid opening/closing electric jack fuse (15 A)	RX	Engine start safety relay
F1B	Hazard warning light fuse (10 A)	RY	Engine start safety relay
F2B	Brake light/horn fuse (10 A)	S1	Glow plug warning light
F3B	Left side running light fuse (10 A)	S2	Battery warning light
F4B	Right side running light fuse (10 A)	S3	Engine oil warning light
F5B	Low beam fuse (15 A)	S4	Engine coolant warning light
F6B	High beam fuse (15 A)	S5	Parking brake warning light
F7B	Cigarette lighter fuse (20 A)	S6	Lifted hopper warning light
G1	Dust control system water level indicator	S7	Running light indicator light
G2	Fuel level indicator	S8	High beam indicator light
I1	Skirt lifting switch	S9	Hazard warning light indicator
I2	Hazard warning light switch	S10	Turn signal indicator light
I3	Windscreen wiper/washer switch	S11	Dust control system low water warning light
I4	Water pump switch	S12	Windscreen wiper warning light
I5	Cab blower switch	S13	Dust control system water pump warning light
I6	Climate control system switch (2 speed/1 speed)	S14	Blower warning light
I7	Electric jack switch	S15	Climate control system warning light
L1	Left front turn signal	S16	Low fuel warning light
L2	Right rear turn signal	S17	Hopper lid opening/closing electric jack warning light
		TM	Climate control system thermostat
		K	Glow plugs

(*) Optional for some countries.

ELECTRICAL SYSTEM

COMPONENT LOCATION (Continues)

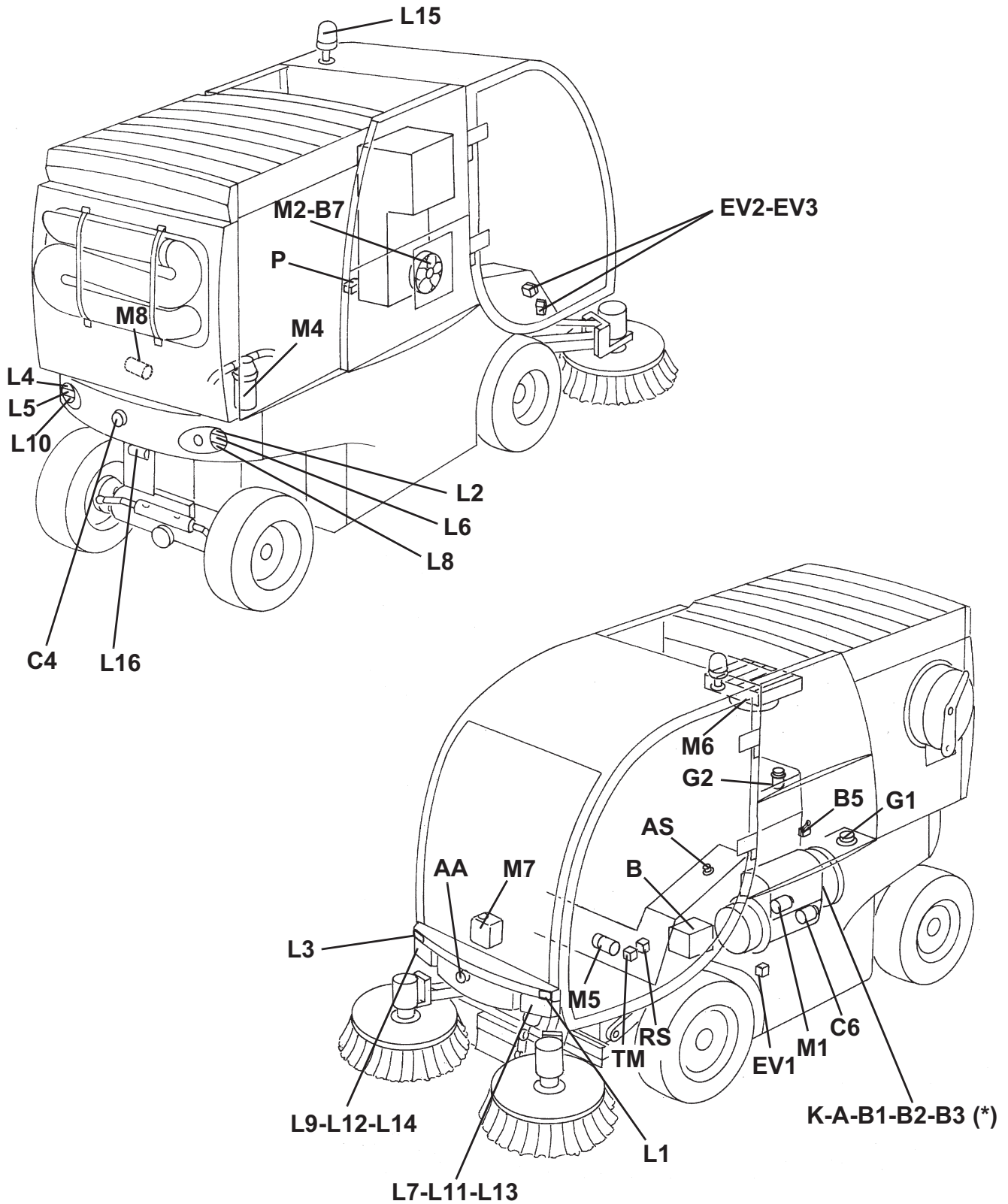

S301503

(*) See the Diesel Engine Manual

ELECTRICAL SYSTEM

COMPONENT LOCATION (Continues)

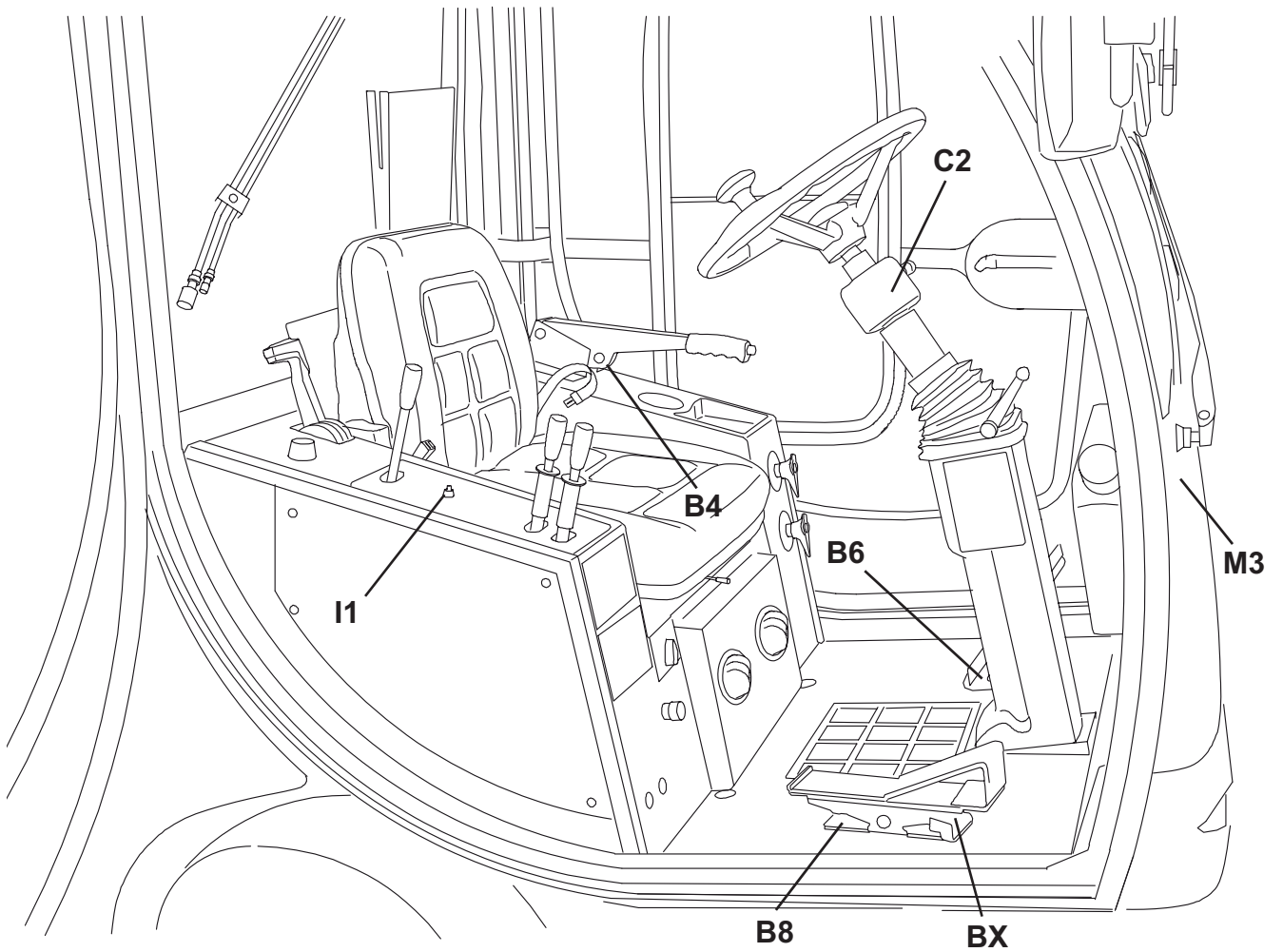
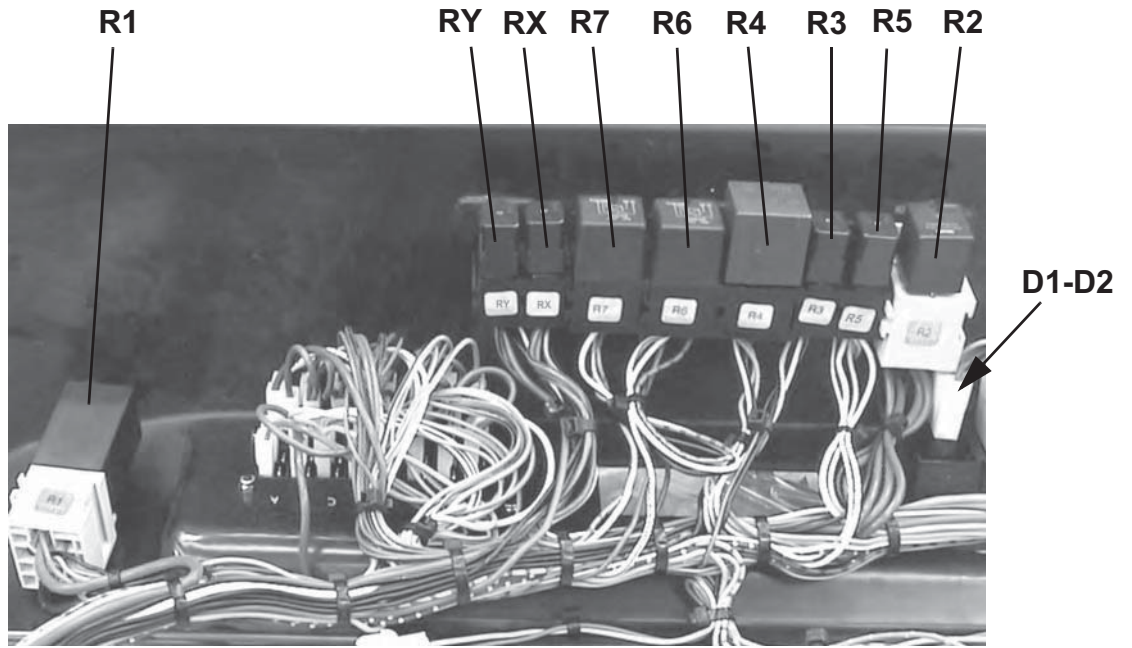

S301504

ELECTRICAL SYSTEM

COMPONENT LOCATION (Continues)

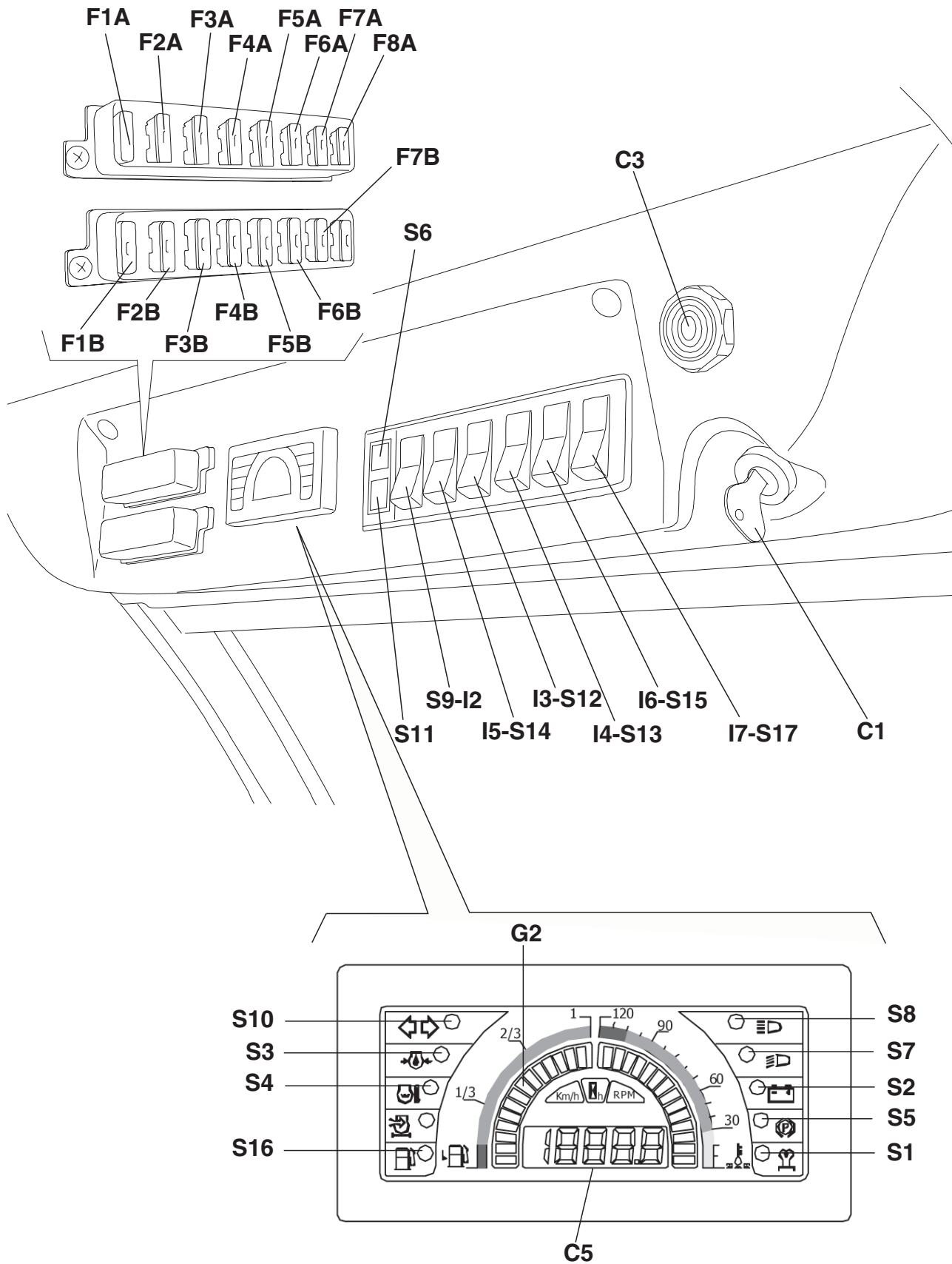

S301505

ELECTRICAL SYSTEM

WIRING DIAGRAM

A	Alternator	L1	Left front turn signal
AA	Horn	L2	Right rear turn signal
AS	Cigarette lighter	L3	Right front turn signal
B	12 V battery	L4	Left rear turn signal
B1	Engine coolant temperature bulb	L5	Left brake light
B2	Engine oil bulb	L6	Right brake light
B3	Engine coolant warning light bulb	L7	Left front running light
B4	Parking brake microswitch	L8	Right rear running light
B5	Lifted hopper microswitch	L9	Right front running light
B6	Brake light microswitch	L10	Left rear running light
B7	Hydraulic system oil cooler fan bulb	L11	Left low beam
B8	Reverse gear sensor	L12	Right low beam
BX	Engine start safety sensor	L13	Left high beam
C1	Ignition switch	L14	Right high beam
C2	Combination switch	L15	Flashing light
C3	Warning buzzer/parking brake buzzer	L16	Licence plate light
C4	Reverse gear buzzer	M1	Starter
C5	Hour counter/revolution counter/water temperature indicator	M2	Hydraulic system oil cooler fan motor
C6	Climate control system compressor	M3	Windscreen wiper motor
D1	Diode	M4	Dust control system water pump (normal)
D2	Diode	M5	Cab blower motor
EV1	Fuel solenoid valve	M6	Climate control system blower motor
EV2	Skirt solenoid valve	M7	Windscreen washer motor with tank
EV3	Skirt solenoid valve	M8	Hopper lid opening/closing electric jack motor
F1A	Hydraulic system oil cooler fan/skirt solenoid valve fuse (20 A)	P	Climate control system pressure switch
F2A	Fuel solenoid valve fuse (10 A)	R1	Engine glow plug control unit relay
F3A	Cab blower/flashing light/windscreen wiper fuse (15 A)	R2	General relay
F4A	Dust control system water pump fuse (10 A) Dust control system water pump/climate control system (optional) fuse (20 A)	R3	Reverse gear buzzer relay
F5A	Reverse gear buzzer fuse (10 A)	R4	Turn signal intermittence relay
F6A	Warning lights/glow plug control unit fuse (10 A)	R5	Water pump relay
F7A	Electric jack warning light fuse (10 A)	R6	Climate control system compressor relay (*)
F8A	Hopper lid opening/closing electric jack fuse (15 A)	R7	Climate control system condenser fan relay (*)
F1B	Hazard warning light fuse (10 A)	RS	Cab blower resistance
F2B	Brake light/horn fuse (10 A)	RX	Engine start safety relay
F3B	Left side running light fuse (10 A)	RY	Engine start safety relay
F4B	Right side running light fuse (10 A)	S1	Glow plug warning light
F5B	Low beam fuse (15 A)	S2	Battery warning light
F6B	High beam fuse (15 A)	S3	Engine oil warning light
F7B	Cigarette lighter fuse (20 A)	S4	Engine coolant warning light
G1	Dust control system water level indicator	S5	Parking brake warning light
G2	Fuel level indicator	S6	Lifted hopper warning light
I1	Skirt lifting switch	S7	Running light indicator light
I2	Hazard warning light switch	S8	High beam indicator light
I3	Windscreen wiper/washer switch	S9	Hazard warning light indicator
I4	Water pump switch	S10	Turn signal indicator light
I5	Cab blower switch	S11	Dust control system low water warning light
I6	Climate control system switch (2 speed/1 speed)	S12	Windscreen wiper warning light
I7	Electric jack switch	S13	Dust control system water pump warning light
		S14	Blower warning light
		S15	Climate control system warning light
		S16	Low fuel warning light
		S17	Hopper lid opening/closing electric jack warning light
		TM	Climate control system thermostat
		K	Glow plugs

(*) Optional for some countries.

ELECTRICAL SYSTEM

WIRING DIAGRAM (Continues)

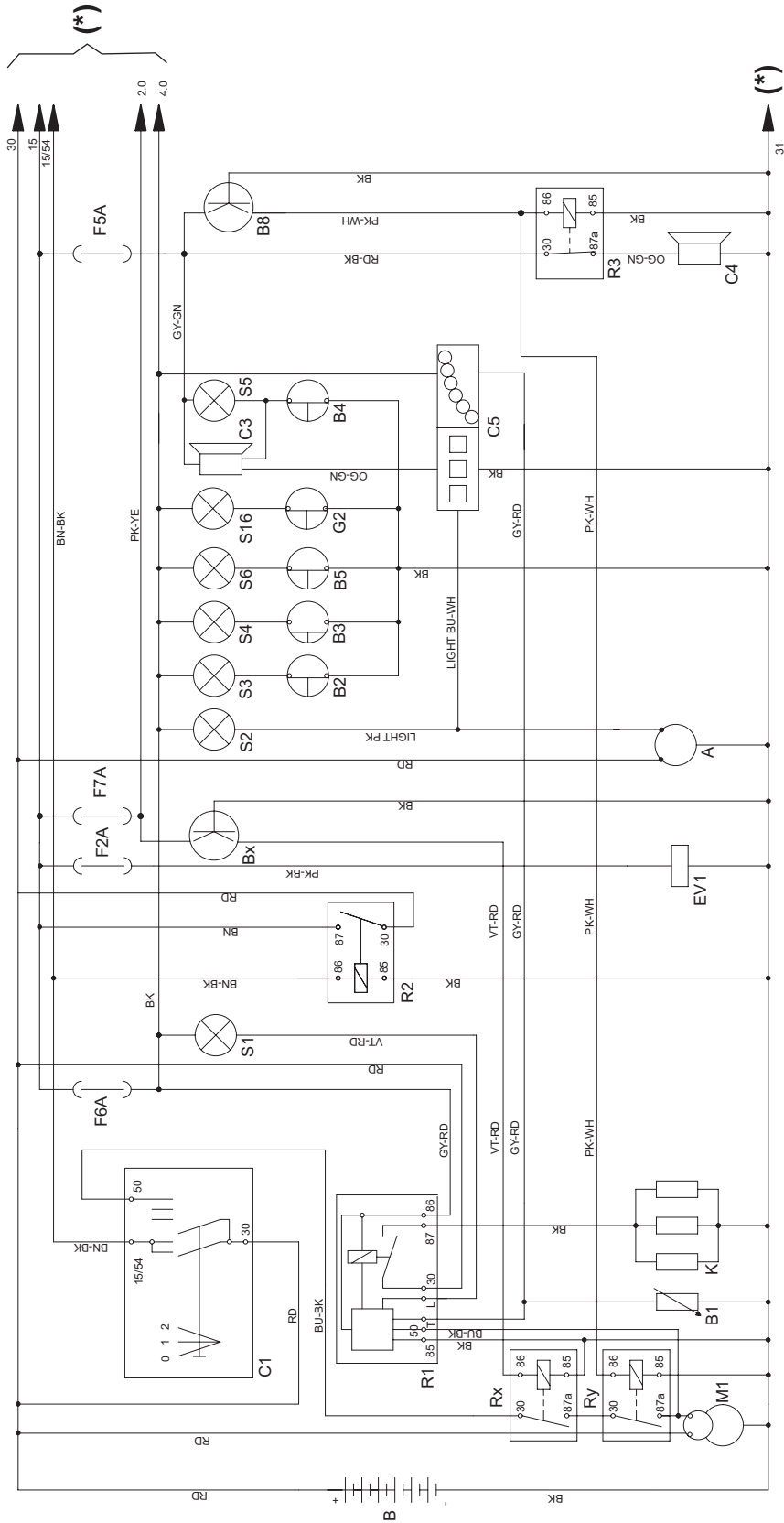

Color code

BK	Black
BU	Blue
BN	Brown
GN	Green
GY	Grey
OG	Orange
PK	Pink
RD	Red
VT	Violet
WH	White
YE	Yellow
LIGHT BU	Light blue
LIGHT PK	Light pink

(*) Continues to the next page

S301506

WIRING DIAGRAM (Continues)

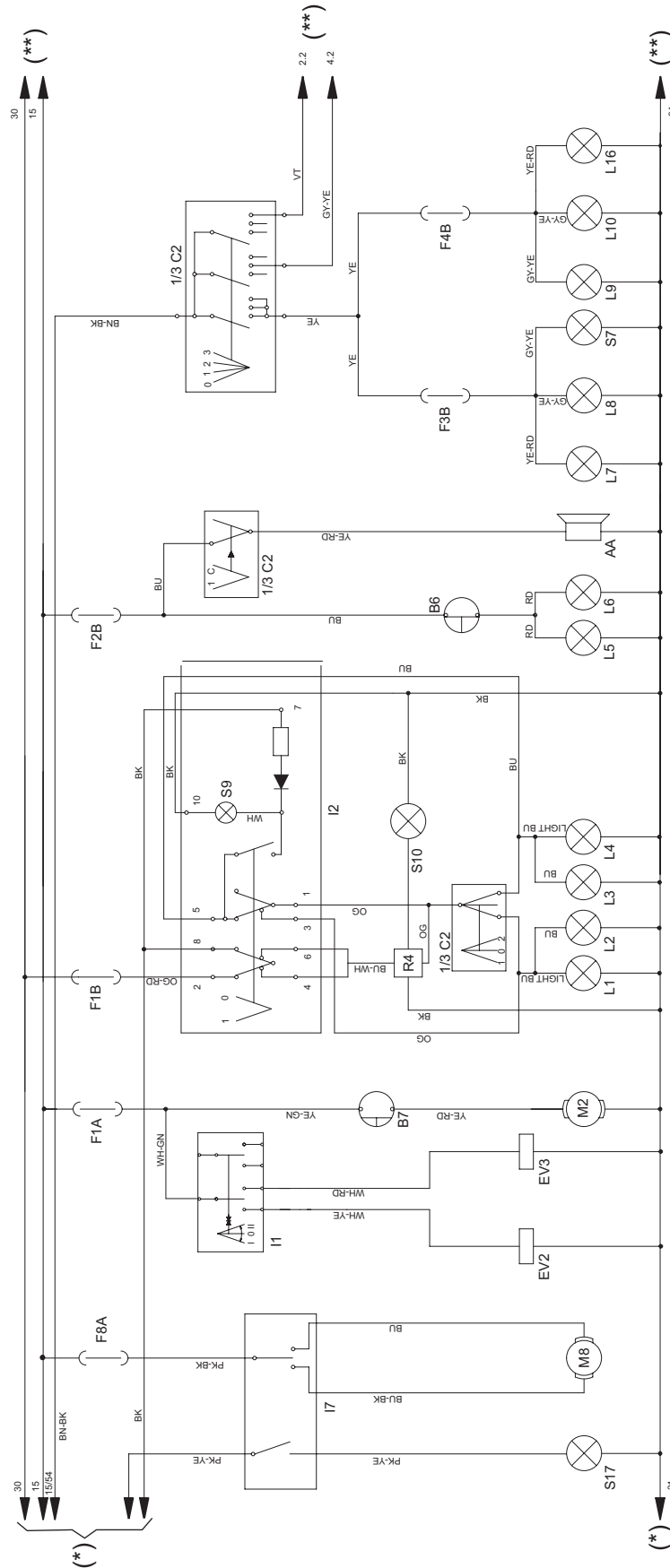

(*) Continues from the previous page

(**) Continues to the next page

ELECTRICAL SYSTEM

WIRING DIAGRAM (Continues)

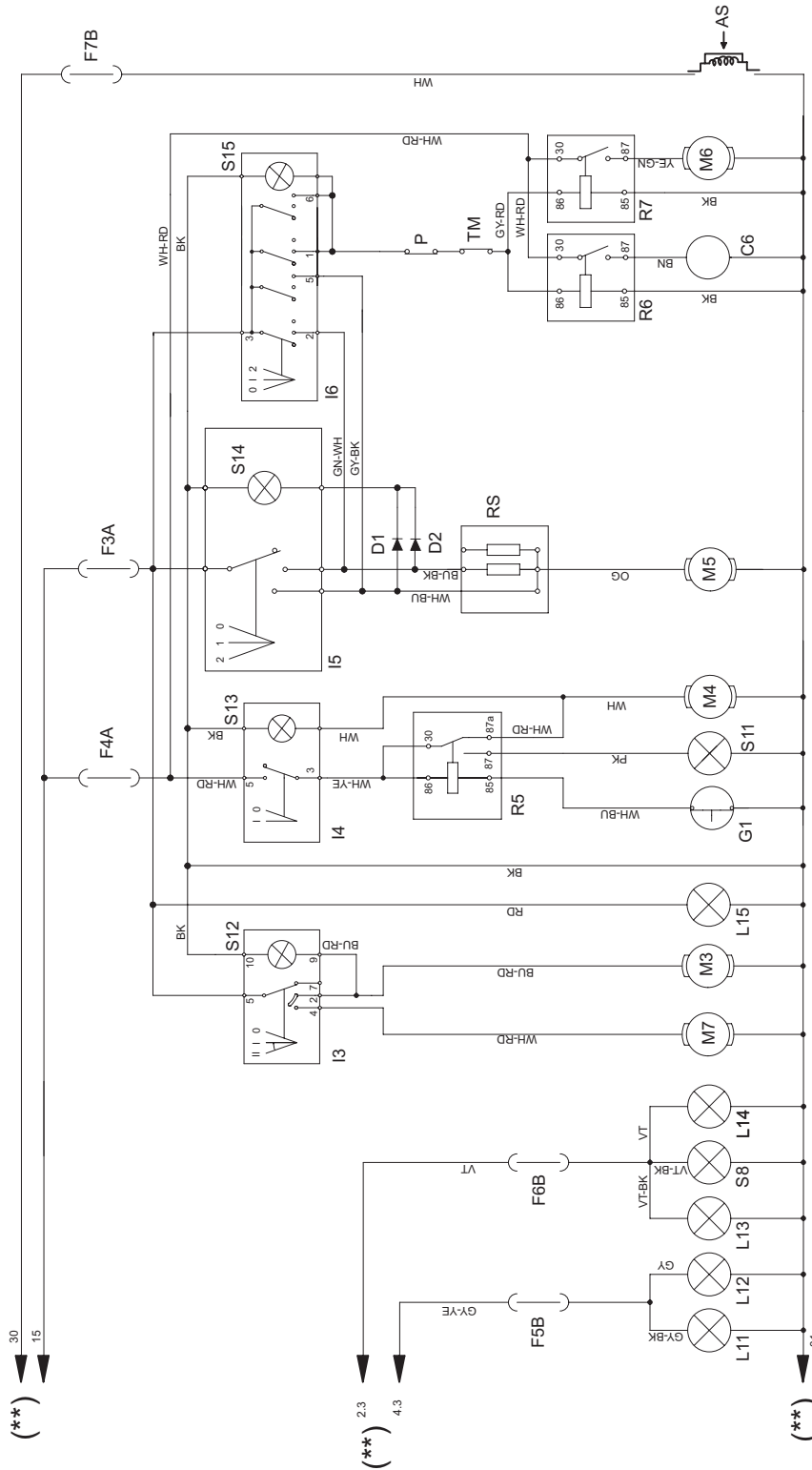

S301506

(**) Continues from the previous page

TROUBLESHOOTING

See the previous chapters related to the use of the electrical system.

Other possible causes:

1. The fuses are burnt (replace).
2. The harness is cut or pressed (repair).

ELECTRICAL SYSTEM

BATTERY FLUID LEVEL CHECK

**WARNING!**

Protect body parts (eyes, hair, hands, etc.) properly, when performing battery check and cleaning procedures.

1. Engage the parking brake with the lever (66).
2. Turn the ignition key (76) to OFF position and remove it.
3. Remove the screws and the left panel (23) in the cab.
4. Check the electrolyte level in the battery (A) and, if necessary, top up.
5. If necessary, clean the battery.
6. Check the battery terminal connections for oxidation.
7. Install the left panel (23) in the cab and the screws.

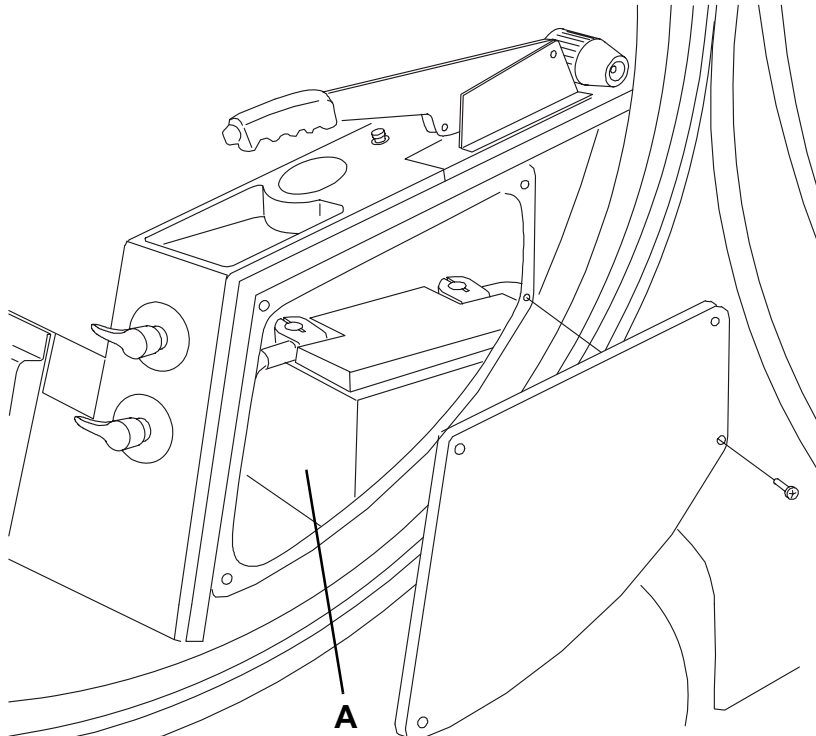

S301507

FUSE REPLACEMENT

- Engage the parking brake with the lever (66).
- Turn the ignition key (76) to OFF position and remove it.
- Operating on the cab dashboard, remove the transparent cover of the fuse box (A) or (B) and replace the suspected fuse among the following:

Fuse box B

- A) Hazard warning light fuse (10 A)
- B) Brake light/horn fuse (10 A)
- C) Left side running light fuse (10 A)
- D) Right side running light fuse (10 A)
- E) Low beam fuse (15 A)
- F) High beam fuse (15 A)
- G) Cigarette lighter fuse (20 A)
- H) Free fuse holder

Fuse box A

- I) Hydraulic system oil cooler fan/skirt solenoid valve fuse (20 A)
 - J) Fuel solenoid valve fuse (10 A)
 - K) Cab blower/flashing light/windscreen wiper fuse (15 A)
 - L) Dust control system water pump fuse (10 A)
 - Dust control system water pump/climate control system (optional) fuse (20 A)
 - M) Reverse gear buzzer fuse (10 A)
 - N) Warning lights/glow plug control unit fuse (10 A)
 - O) Electric jack warning light fuse (10 A)
 - P) Hopper lid opening/closing electric jack fuse (15 A)
- Install the transparent cover of the fuse box (A) or (B).

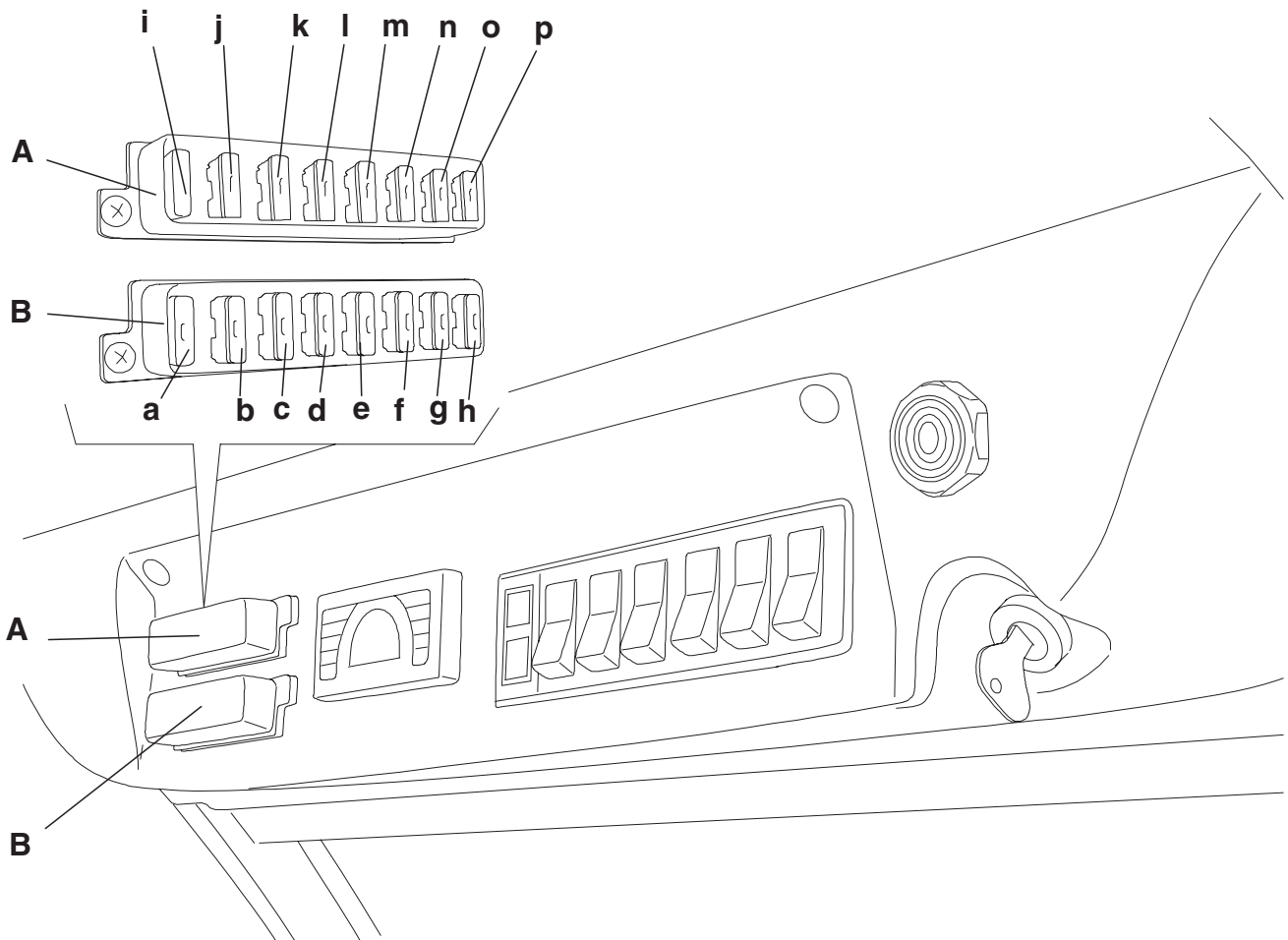

S301429

ELECTRICAL SYSTEM

RELAY REPLACEMENT

1. Engage the parking brake with the lever (66).
2. Turn the ignition key (76) to OFF position and remove it.
3. Remove the screws (C) and lower the dashboard panel (D) in the cab.
4. Remove the suspected relay among the following:
 - General relay (R2)
 - Water pump relay (R5)
 - Reverse gear buzzer relay (R3)
 - Turn signal intermittence relay (R4)
 - Climate control system compressor relay (R6) (optional)
 - Condenser fan relay (R7) (optional)
 - Engine glow plug control unit relay (R1)
 - Engine start safety relay (RX)
 - Engine start safety relay (RY)
5. Assemble the components in the reverse order of disassembly.

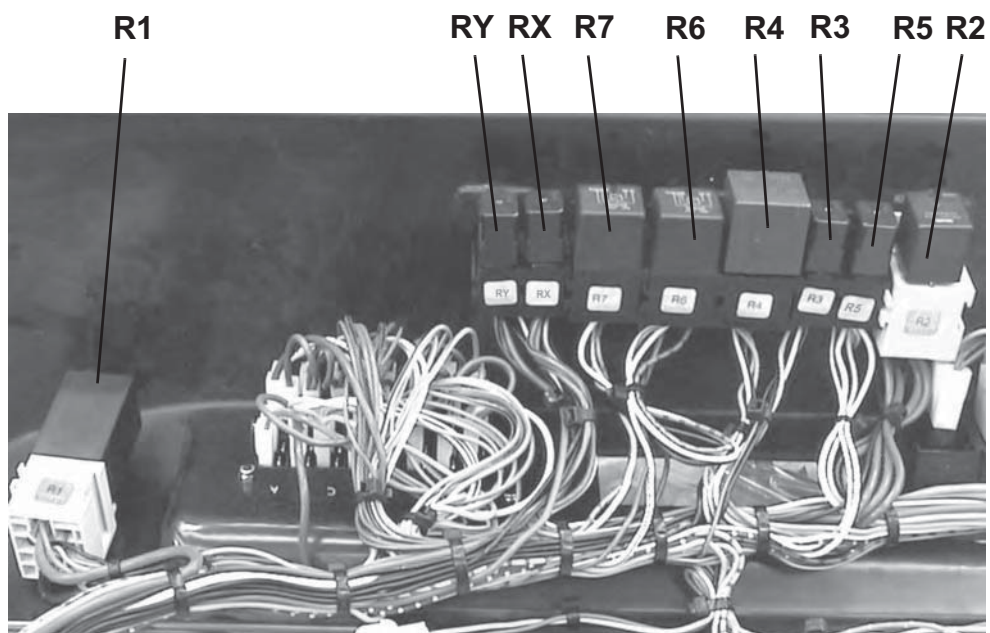
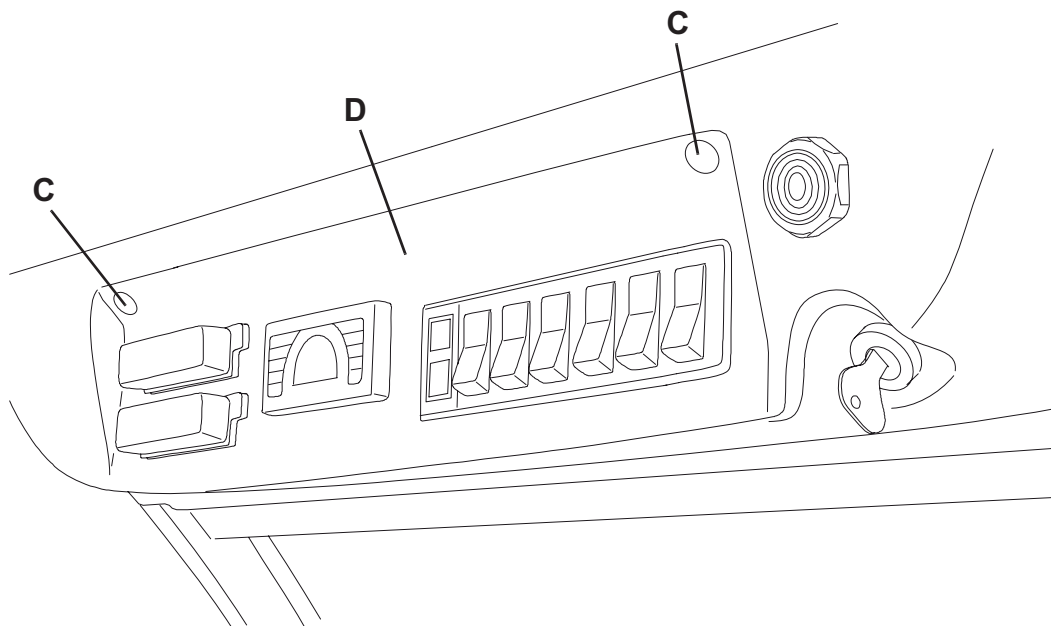

S301508

CONTROL PANEL DISPLAY REPLACEMENT

1. Engage the parking brake with the lever (66).
2. Turn the ignition key (76) to OFF position and remove it.
3. Remove the screws and the left panel (23) in the cab.
4. Disconnect the negative pin from the battery (A).
5. Remove the screws (C) and lower the dashboard panel (D) in the cab.
6. Remove the screws (E) and lower the display (F).
7. Disconnect the connectors (G) and (H), then recover the display (F).
8. Install the new display by performing steps 6 and 7 in the reverse order.
9. Adjust the display by using the keyboard of tool no. 33014099 connected to connectors (I) and (J).

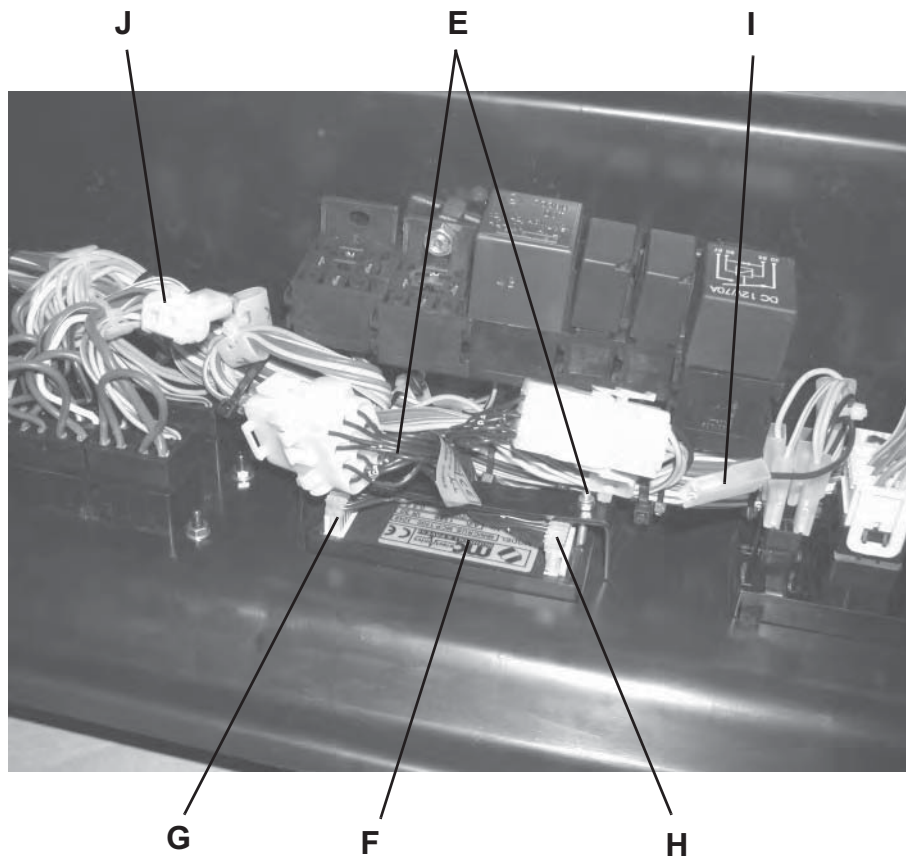
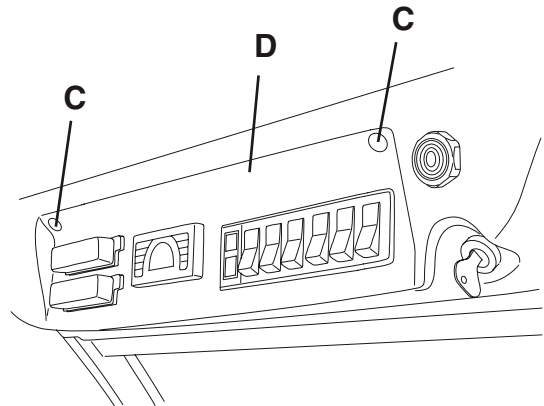
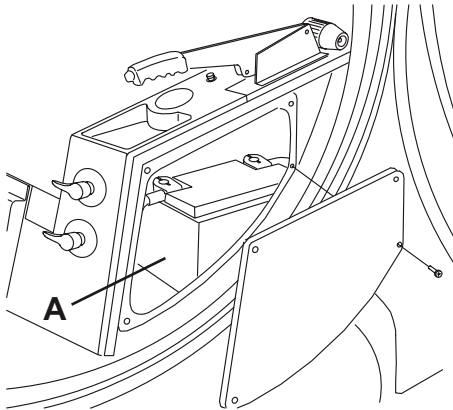

S301509

ELECTRICAL SYSTEM

LOW BEAM AND HIGH BEAM ADJUSTMENT AND BULB REPLACEMENT

Preliminary operations

1. Drive the machine on a solid and level ground, then engage the parking brake with the lever (66).
2. Turn the ignition key (76) to OFF position and remove it.

Bulb replacement

3. Remove the screws (A) and move the headlight (B).
4. Replace the burned bulbs.
5. Install the headlight (B) and fasten it with the screws (A).
6. Adjust the headlights according to the following procedure.

Low beam adjustment

7. Use the screws (C) and (D), in the following way:
 - To adjust the beam vertically, turn the screws (C) and (D) simultaneously;
 - To adjust the beam horizontally, turn the screws (C) and (D) individually.



S300929



Nilfisk-Advance SpA

Registered office: Via F. Turati 16/18, 20121 Milano

Administrative office: Strada Comunale della Braglia n° 18

26862 Guardamiglio (Lodi)

www.nilfisk-advance.com

Phone: +39 0377 451124

Fax: +39 0377 51443

Printed in Italy