

NINJA®

QB1004 Series
OWNER'S GUIDE

Master Prep® Professional



ninjakitchen.com
1 877 646-5288

IMPORTANT SAFETY INSTRUCTIONS

For Household Use Only

WHEN USING ELECTRICAL APPLIANCES, BASIC SAFETY PRECAUTIONS SHOULD ALWAYS BE FOLLOWED, INCLUDING THE FOLLOWING:

READ ALL INSTRUCTIONS BEFORE USING YOUR NINJA® MASTER PREP® PROFESSIONAL.

POLARIZED PLUG

⚠ WARNING: To reduce the risk of electric shock, this appliance has a polarized plug (one blade is wider than the other). This plug will fit into a polarized outlet only one way. If the plug does not fit fully into the outlet, reverse the plug. If it still does not fit, contact a qualified electrician to install the proper outlet. **DO NOT** modify the plug in any way.

⚠ WARNING: Extension cords are not recommended for use with this product.

⚠ WARNING:

TO REDUCE THE RISK OF FIRE, ELECTRIC SHOCK OR INJURY:

- 1 ⚠ WARNING:** Remove utensils prior to processing. Failure to remove may cause the jar to be damaged or to shatter which may cause personal injury.
- 2 ⚠ WARNING:** The Blade Assemblies are sharp, not locked in place and removable, handle with care. When handling the Blade Assemblies, always hold them by the shaft. Failure to do so will result in a risk of laceration.
- 3 ⚠ WARNING:** The Blade Assemblies are sharp and not locked in place. When pouring, carefully remove the Blade Assembly first, holding it by the shaft. Failure to do so will result in a risk of laceration.
- 4 ⚠ WARNING:** The Blade Assemblies are sharp and not locked in place. Make sure to carefully remove the splashguard and Blade Assembly, holding it by the shaft. Replace the splashguard before emptying contents of the pitcher or Master Prep Professional Bowl. Failure to do so will result in a risk of laceration.
- 5 ⚠ CAUTION:** **DO NOT** blend hot liquids, doing so may cause excessive pressure build-up, resulting in risk of the user being burned.
- 6** To protect against electrical shock, **DO NOT** submerge the appliance or allow the power cord to come into contact with water or any other liquid.

- 7 **DO NOT** allow the appliance to be used by children. Close supervision is necessary when used near children. This is not a toy.
- 8 Never leave an appliance unattended when in use.
- 9 Appliance accessories are not intended to be used in the microwave as it may result in damage to the accessories.
- 10 Remove the Master Pod from the appliance and unplug the power cord from the electrical outlet when not in use, before assembling or disassembling parts and before cleaning. To unplug, grasp the plug and pull from the electrical outlet. Never pull from the power cord.
- 11 **DO NOT** abuse the power cord. Never carry the Master Pod by the power cord or yank it to disconnect from electrical outlet; instead grasp the plug and pull to disconnect.
- 12 **DO NOT** operate any appliance with a damaged cord or plug, or after the appliance malfunctions, has been dropped or damaged in any manner. This appliance has no serviceable parts. Return the appliance to SharkNinja Operating LLC for examination, repair or adjustment.
- 13 **DO NOT** let the power cord hang over the edge of table or counter or touch hot surfaces such as the stove.
- 14 Always use appliance on a dry, level surface.
- 15 Keep hands, hair, clothing, as well as utensils out of container while processing to reduce the risk of severe injury to persons or damage to the appliance. A scraper may be used but only when the appliance is not running.
- 16 Avoid contact with moving parts.
- 17 **DO NOT** attempt to sharpen blades.
- 18 **DO NOT** use the appliance if blade assemblies are bent or damaged.
- 19 **DO NOT** expose pitcher or the chopping bowl to extreme temperature changes.
- 20 **DO NOT** use pitcher or chopping bowl if it is cracked or chipped.
- 21 To reduce the risk of injury, **NEVER** operate the appliance without the splashguard in place.
- 22 **DO NOT** operate this appliance on or near any hot surfaces (such as gas or electric burner or in a heated oven).
- 23 The use of accessory attachments, including canning jars not recommended by the manufacturer may cause fire, electrical shock or risk of personal injury.
- 24 **DO NOT** remove the Master Pod before the Blade Assemblies have stopped turning.
- 25 **DO NOT** overfill.
- 26 **DO NOT** operate the appliance empty.
- 27 **DO NOT** try to defeat the interlock mechanism. Make sure that the 4-Blade Assemblies are properly inserted before operating the appliance.
- 28 Immediately release the On/Off pulse button on the Master Pod in the event that the appliance malfunctions during use.
- 29 **DO NOT** operate the appliance for more than 15 seconds.
- 30 If the appliance overheats, a thermal switch will become activated and shut off the motor. To reset, unplug the appliance and let it cool down for approximately 10 minutes before using again.
- 31 **THIS PRODUCT IS INTENDED FOR HOUSEHOLD USE ONLY.** Do not use this appliance for anything other than its intended use. **DO NOT** use outdoors.

SAVE THESE INSTRUCTIONS

THIS BOOK COVERS MODEL NUMBERS:

QB1004
QB1004CO
QB1004LD

TECHNICAL SPECIFICATIONS

Voltage: 120V., 60Hz.
Power: 450 Watts
Pitcher Capacity: 48 oz. (6 cups, 1.5 L)
40 oz. (5 cups, 1.25 L)
Bowl Capacity: 16 oz. (2 cups, 500 ml)



Contents

**Thank you for
purchasing
the Ninja®
Master Prep®
Professional.**

Getting Started	5
Before First Use	7
Assembly and Use of the Pitchers	8
Assembly and Use of the Master Prep Bowl	10
Cleaning and Maintenance	12
Troubleshooting Guide.....	13
Replacement Parts	13
Warranty & Registration.....	14

Getting Started

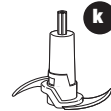
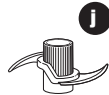
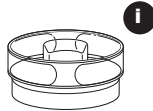
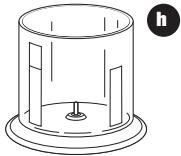
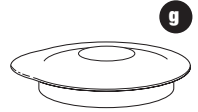
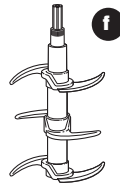
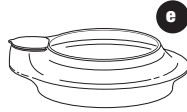
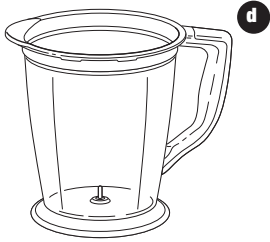
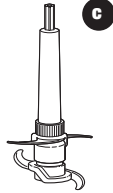
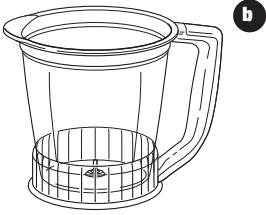
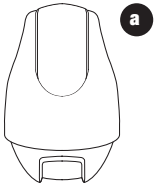

- a** Master Pod
- b** Master Prep® Professional 40 oz. Pitcher with Non-Slip Base
- c** Ninja® 4-Blade Assembly
- d** Master Prep® Professional 48 oz. Pitcher with Non-Slip Base
- e** Pitcher Splashguard
- f** Ninja® 6-Blade Assembly
- g** Pitcher Storage Lid

- h** Master Prep Professional Bowl with Non-Slip Base
- i** Bowl Splashguard
- j** Upper Chopping Blade Assembly (bowl)
- k** Lower Chopping Blade Assembly (bowl)
- l** Bowl Storage Lid
- m** Power Cord (not shown)

NOTE: Attachments are not interchangeable.

The Ninja® Master Prep® Professional is an indispensable kitchen tool that is perfect for blending, chopping, mixing or pureeing when preparing your favorite recipes. For best results, be sure to carefully read all the instructions contained in the manual before using this appliance.

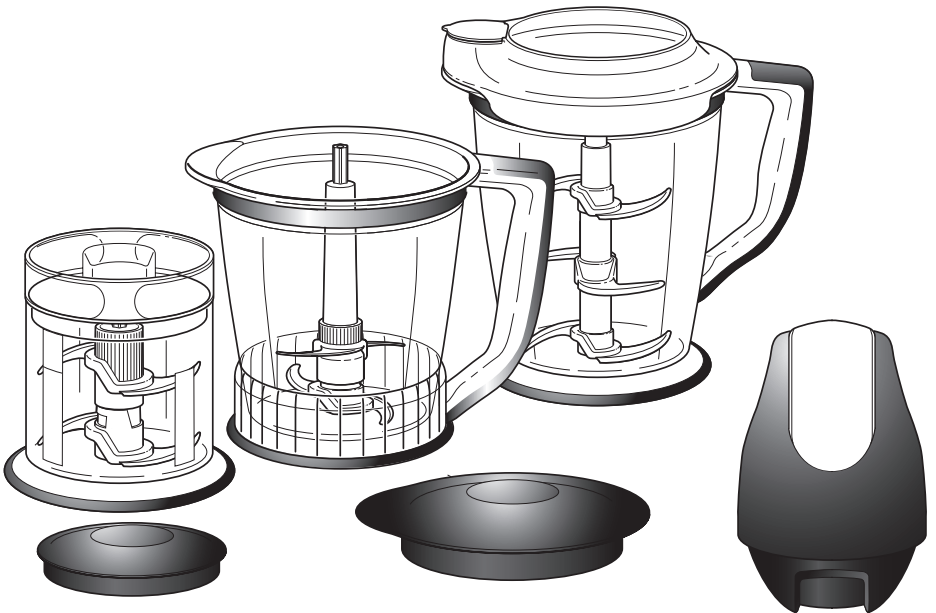

450 Watt Master Pod

The 450 watt Master Pod operates on 120V., 60Hz. electrical power. **NEVER** allow the Master Pod to become wet when plugged into an electrical outlet.

- ⚠ WARNING:** The Master Pod should never be immersed in water or any other liquid.
- ⚠ CAUTION:** Make sure that the Master Pod is unplugged from the electrical outlet and that the Blade Assemblies have stopped turning before removing from the bowl or pitchers.
- ⚠ CAUTION:** The Blade Assemblies are sharp and not locked in place. Make sure to carefully remove the splashguard and Blade Assembly, holding it by the shaft, before emptying contents of the pitcher or the Master Prep Professional Bowl. Failure to do so will result in a risk of laceration.

IMPORTANT: Never run the appliance empty.

Before First Use

⚠ WARNING: Blade Assemblies are sharp and not locked in place. If using the pour spout, ensure that the splashguard is fully on the pitcher. Failure to do so will result in a risk of laceration.

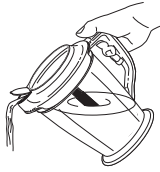

⚠ WARNING: Blade Assemblies are sharp and not locked in place. Make sure to carefully remove the splashguard and Blade

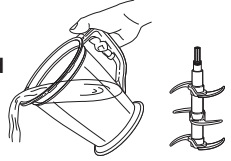

Assembly, holding it by the shaft. Replace the splashguard before emptying contents of the pitcher. Failure to do so will result in a risk of laceration.

PLEASE KEEP THESE IMPORTANT SAFEGUARDS IN MIND WHEN USING THE APPLIANCE:

IMPORTANT: Make sure that the Master Pod is plugged in for use.

IMPORTANT: Never add ingredients into the container before placing the Blade Assemblies in first.

IMPORTANT: Attachments are not interchangeable.

IMPORTANT: DO NOT attempt to operate the appliance without the splashguard on.

IMPORTANT: Never run the appliance empty.

IMPORTANT: Appliance accessories are not intended to be used in the microwave as it may result in damage to the accessories.

⚠ WARNING: DO NOT try to place the Blade Assemblies onto the Master Pod and then into the Master Prep Professional pitchers. Always assemble the Ninja 6-Blade and Ninja 4 Blade Assembly inside the pitchers.



⚠ CAUTION: DO NOT immerse the Master Pod into water or any other liquid.

- 1 Remove all packaging material and labels from the appliance. Separate/remove all parts from each other.
- 2 Wash the lids, splashguards, bowl, pitchers, and blade assemblies in warm, soapy water. When washing the blade assemblies use a dish-washing utensil with a handle to avoid direct hand contact with blades.

⚠ WARNING: Handle the blade assemblies with care when washing, as the blades are sharp.

- 3 Handle the blade assemblies with care to avoid contact with sharp edges. Rinse and air dry thoroughly.
- 4 The pitchers, bowl, lids, splashguards, and Blade Assemblies are all dishwasher safe. It is recommended that the lids, splashguards and blade assemblies be placed on the top rack. Ensure that the blade assemblies are removed from the pitcher and the bowl before placing in the dishwasher.
- 5 Wipe the motor base clean with a damp cloth.

Assembly and Use of the Pitchers

- ⚠ **WARNING:** Handle the Ninja 4-Blade and 6-Blade Assemblies with care, as the blades are sharp.
 - ⚠ **WARNING:** Remove utensils prior to processing. Failure to remove may cause the pitcher to be damaged or to shatter, which may cause personal injury.
 - ⚠ **WARNING:** DO NOT try to place the Ninja 4-Blade or 6-Blade Assemblies onto the Master Pod and then into the pitcher.
 - ⚠ **WARNING:** DO NOT attempt to operate the appliance without the safety splashguard in place.
 - ⚠ **WARNING:** Never leave the appliance unattended while in use.
 - ⚠ **CAUTION:** DO NOT blend hot liquids, doing so may cause excessive pressure buildup, resulting in risk of the user being burned.
- IMPORTANT:** Make sure that the Master Pod is plugged in for use.

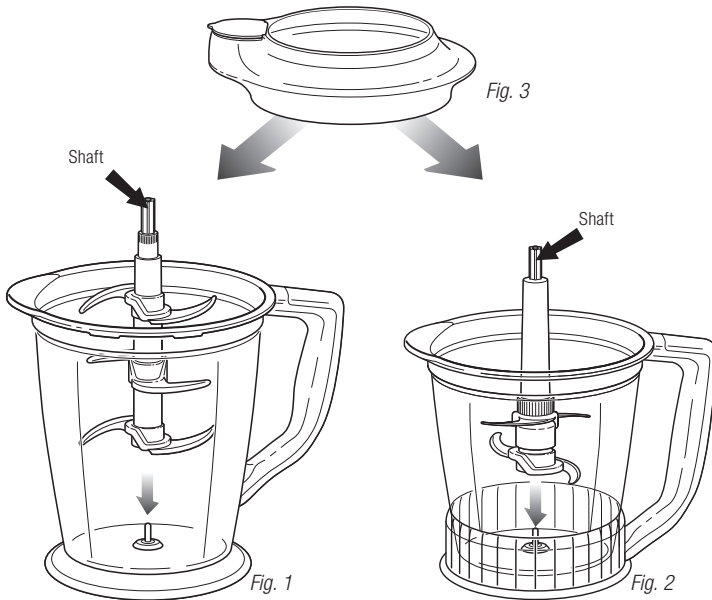

- 1 Review warning and caution statements above before proceeding to number 2.
 - 2 Place the pitcher on a clean, dry, level surface.
 - 3 Holding the Ninja® 4-Blade Assembly or Ninja 6-Blade Assembly by the shaft, place it onto the spindle pin inside the Master Prep® Professional pitcher.
- Use the Ninja 6-Blade Assembly in the 48 oz. Pitcher. (fig. 1)
 - Use the Ninja 4-Blade Assembly in the 40 oz. Pitcher. (fig. 2)

IMPORTANT: Place the Ninja Blade Assemblies inside the pitcher carefully as blades are sharp.

- 4 Add the ingredients to be processed into the Ninja Master Prep Professional pitcher.
- 5 Place the pitcher splashguard onto the top of the Ninja Master Prep Professional pitcher. (fig. 3)

IMPORTANT: Never add ingredients into the Ninja Master Prep Professional pitcher before placing the blade assembly in first.

Assembly and Use of the Pitchers - cont.

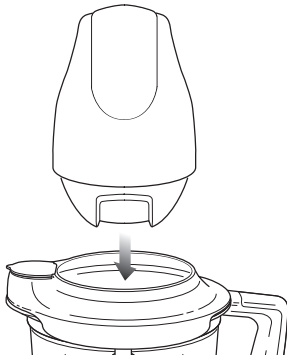

Fig. 4

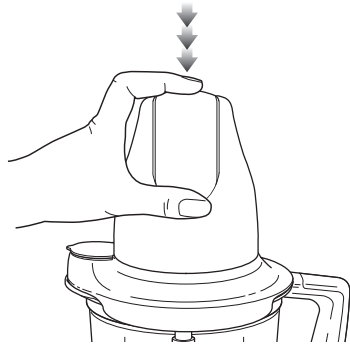

Fig. 5

6 Review warning and caution statements on page 8 before proceeding to number 7.

7 Place the Master Pod on top of the pitcher splashguard making sure that it is securely in place. **(fig. 4) DO NOT** attempt to operate the appliance without the safety splashguard in place.

8 To start the appliance, plug the power cord into the electrical outlet, securely hold Master Pod while operating and press on the On/Off pulse button located on the top of the power head. **(fig. 5)**

9 Hold the Ninja® Master Prep® Professional pitcher firmly while depressing the On/Off pulse button to ensure the unit stays in place.

NOTE: DO NOT operate the appliance continuously for more than 15 seconds at a time.

10 To stop the appliance, remove your fingers from the On/Off pulse button.

10 In order to obtain a better quality of chopping, operate the appliance by using the "pulse" method.

12 Make sure that the Blade Assembly has stopped completely before removing the Master Pod.

13 If the ingredients stick to the side of the Master Prep Professional pitcher, stop the appliance, remove the Master Pod and the splashguard. Use a spatula to dislodge the pieces and then replace the splashguard and the Master Pod. Continue processing.

14 Depending on the consistency of the contents, use the pouring spout to empty liquid contents.

15 For thicker consistencies, first remove the pitcher splashguard. Then, carefully remove the Blade Assemblies by the top of the shaft. Place blade assemblies away from the work area to avoid accidental contact. Finally, empty contents from the pitcher.

HINTS & TIPS FOR USING YOUR NINJA MASTER PREP PROFESSIONAL

- To crush ice into snow, start by using short pulses to break up large chunks. Continue until snow is achieved.

Assembly and Use of the Master Prep® Bowl

- ⚠ **WARNING:** Handle the Upper and Lower Chopping Bowl Blade Assemblies with care, as the blades are sharp.
- ⚠ **WARNING:** Remove utensils prior to processing. Failure to remove may cause the bowl to be damaged or to shatter, which may cause personal injury.
- ⚠ **WARNING:** DO NOT try to place the Blade Assemblies onto the Master Pod and then into the bowl.
- ⚠ **WARNING:** DO NOT attempt to operate the appliance without the safety splashguard in place.
- ⚠ **WARNING:** DO NOT crush ice in Master Prep Bowl or damage may occur to the unit.
- ⚠ **WARNING:** Never leave the appliance unattended while in use.
- ⚠ **CAUTION:** DO NOT blend hot liquids, doing so may cause excessive pressure buildup, resulting in risk of the user being burned.
- ⚠ **CAUTION:** Upper and Lower Chopping Bowl Blade Assemblies are loose and not locked in place. Make sure to remove the Chopping Blade Assembly before emptying contents of processor bowl.
IMPORTANT: Make sure that the Master Pod is plugged in for use.

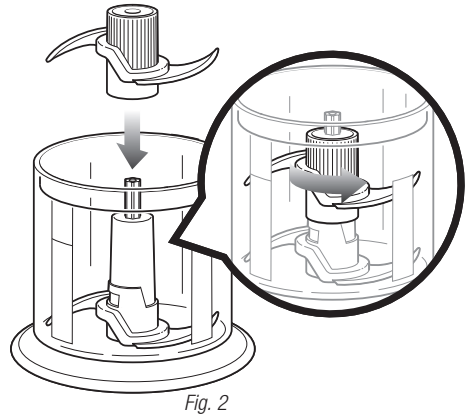
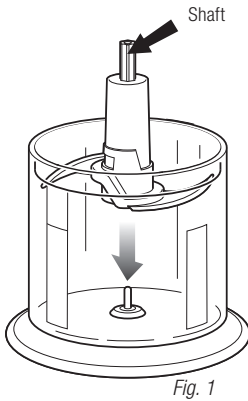

- 1 Review warning and caution statements above before proceeding to number 2.
- 2 Place the Master Prep Professional Bowl on a clean, dry, level surface.
- 3 Holding the Lower Chopping Blade Assembly by the shaft, place it over the spindle pin inside the Master Prep Professional Bowl. (**fig. 1**)
- 4 Carefully insert the Upper Chopping Blade Assembly over the Lower Chopping Blade Assembly rotating it until it locks onto the Lower Chopping Blade Assembly. (**fig. 2**)

IMPORTANT: Always assemble the Chopping Blade Assembly inside the container.



- ⚠ **WARNING:** DO NOT try to place the Upper and Lower Chopping Blade Assembly onto the Master Pod and then into the Master Prep Professional Bowl.

Assembly and Use of the Master Prep® Bowl - cont.

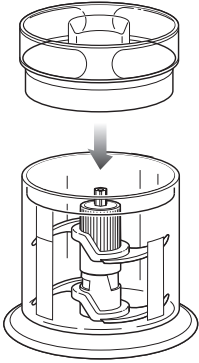

Fig. 3

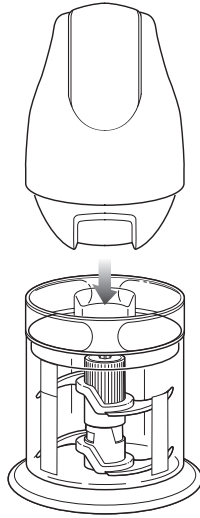

Fig. 4

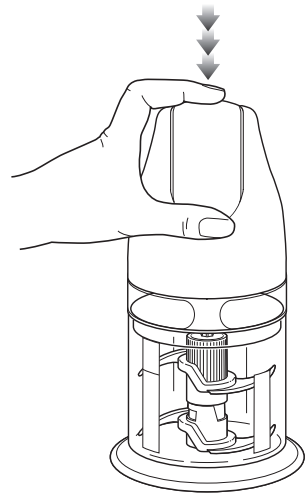

Fig. 5

5 Review warning and caution statements on page 10 before proceeding to number 6.

- 6** Place the food that you want to process into the Master Prep Professional Bowl.

IMPORTANT: Never add ingredients into the Master Prep Professional Bowl before placing the blade assembly in first.

NOTE: DO NOT add more than 2 cups dry or 1 cup liquid ingredients as this will strain the motor and may cause overflow.

- 7** Place the splashguard on the bowl. (fig. 3)
- 8** Place the Master Pod on top of the splashguard making sure that it is securely in place. (fig. 4) **DO NOT** attempt to operate the appliance without the safety splashguard in place.
- 9** To start the appliance, plug the power cord into the electrical outlet, securely hold Master Pod while operating and press on the on/off pulse button located on the top of the Master Pod. (fig. 5)
- 10** Hold the Master Prep® bowl firmly while depressing the On/Off pulse button to ensure the unit stays in place.
- NOTE: DO NOT** operate the appliance continuously for more than 15 seconds at a time. Be careful not to over process. For coarsely chopped foods, use repeated short pulsing action until the desired consistency is reached.
- 11** To stop the appliance, remove your fingers from the On/Off pulse button.

- 12** In order to obtain a better quality of chopping, operate the appliance by using the "pulse" method.

- 13** Make sure that the Chopping Blade Assembly has stopped completely before removing the Master Pod.

- 14** If the ingredients stick to the side of the Master Prep® Professional bowl, stop the appliance, remove the Master Pod and the splashguard. Use a spatula to dislodge the pieces and then replace the splashguard and the Master Pod. Continue processing.

- 15** Blade assembly is loose and not locked in place. Remove the blade assembly by its shaft before you empty the contents of the Master Prep Professional Bowl.

HINTS & TIPS FOR USING YOUR NINJA® MASTER PREP PROFESSIONAL

- The Chopping Blade Assembly can be used for chopping meat, fish, vegetables, cheese etc.
- For mincing, chopping and pureeing, increase the length of pulses.
- For coarse chopping, use short, quick pulses and monitor food texture.
- Pre-cut larger pieces to make them fit into the Master Prep®. When chopping hard foods (e.g. meat, cheese) cut into 1-inch cubes.

Care & Maintenance

HOW TO CLEAN

⚠ CAUTION: Make sure that the Master Pod is unplugged from the power source before inserting or removing any attachment and before cleaning.

⚠ CAUTION: DO NOT immerse the Master Pod into water or any other liquid.

- 1 Separate/remove all parts from each other.
- 2 **Hand Washing:** Wash the lids, splashguards, pitchers, bowl and Blade Assemblies in warm, soapy water. When washing the Blade Assemblies, use a dish-washing utensil with a handle to avoid direct hand contact with blades. Handle the Blade Assemblies with care to avoid contact with sharp edges. Rinse and air dry thoroughly.

Dishwasher: The pitchers, bowl, lids, splashguards, and Blade Assemblies are all dishwasher safe. It is recommended that the lids and blade assemblies be placed on the top rack. Ensure the blade assemblies are removed from the pitchers and the bowl before placing in the dishwasher.

⚠ WARNING: Handle the Blade Assemblies with care when washing, as the blades are sharp. Contact with the blades' edges can result in laceration.

- 3 Wipe the motor base clean with a damp cloth.

Please call customer service if any servicing needs to be performed on the appliance at 1-877-646-5288.

HOW TO STORE

- 1 Store the Master Prep® upright with the blade assembly and splashguard inside the corresponding container. Loosely wrap the power cord around the Master Pod.

RESETTING THE MOTOR THERMOSTAT

The Ninja® Master Prep Professional features a unique safety system which prevents damage to the unit's motor and drive system should you inadvertently overload your appliance. If the appliance is being overloaded, the motor will stop. To reset the appliance, follow the resetting procedure below:

- 1 Unplug the appliance from the electrical outlet.
- 2 Remove the Master Pod and splashguard and empty the container and ensure that no food is jamming the blade assembly.
- 3 Allow the appliance to cool for approximately 10 minutes.
- 4 Replace the splashguard and Master Pod onto the container and re-plug the appliance into the electrical outlet.
- 5 Proceed to use the appliance as before making sure not to exceed the recommended maximum capacities.

Troubleshooting Guide

PROBLEMS	POSSIBLE REASONS & SOLUTIONS
Motor Doesn't Start or Blade Assembly Doesn't Rotate.	<p>Check that the bottom of Master Pod is clean and there is no food blocking connection when placing on containers.</p> <p>There is too much food in the container.</p> <p>The unit has overheated or overloaded. Unplug and wait approximately 10 minutes before using again.</p> <p>Make sure the splashguard is securely on container.</p> <p>Make sure the Master Pod is securely placed on splashguard.</p> <p>Check that the plug is securely inserted into the electrical outlet.</p> <p>Check fuse or breaker. Replace fuse/reset breaker.</p>
Food is Unevenly Chopped.	<p>Either you are chopping too much food at one time, or the pieces are not small enough. Try cutting the food into smaller pieces of even size and processing smaller amounts per batch.</p>
Food is Chopped Too Fine or is Too Watery.	<p>The food has been over processed. Use brief pulses or process for shorter time. Let blade assembly stop completely between pulses.</p>
Food Collects On Splashguard or On the Sides of the Master Prep Professional Pitcher or Master Prep Professional Bowl.	<p>You may be processing too much food. Turn the machine off. When the blade assembly stops rotating, remove the Master Pod and the splashguard. Remove some of the food being processed.</p>
You Cannot Achieve Snow From Solid Ice.	<p>Do not use ice that has been sitting out or has started to melt. Be sure to use short pulses in the beginning to break up large pieces.</p>

Replacement Parts

ORDERING REPLACEMENT PARTS

To order additional parts and attachments, please visit our website: www.ninjakitchen.com or feel free to contact customer service: **1-877-646-5288**.



ONE (1) YEAR LIMITED WARRANTY

SharkNinja Operating LLC warrants this product to be free from material defects and workmanship for a period of one (1) year from the date of purchase when utilized for normal household use, subject to the following conditions, exclusions and exceptions.

The liability of **SharkNinja Operating LLC** is limited solely to the cost of the repair or replacement of the unit at our option. This Limited Warranty does not cover normal wear of parts and does not apply to any unit that has been tampered with or used for commercial purposes. This Limited Warranty does not cover damage caused by misuse, abuse, negligent handling or damage due to faulty packaging or mishandling in transit. This Limited Warranty does not cover damage or defects caused by or resulting from damages from shipping or repairs, service or alteration to the product or any of its parts, which have been performed by a repair person not authorized by **SharkNinja Operating LLC**.

If your appliance fails to operate properly while in use under normal household conditions within the warranty period, return the complete appliance and accessories, freight prepaid. For assistance with warranty service options or customer support, please call our customer care and product specialists at, call 1 (877) 646-5288 or visit our website www.ninjakitchen.com.

If the appliance is found to be defective in material or workmanship, **SharkNinja Operating LLC** will repair or replace it free of charge. Proof of purchase is required and a fee of \$19.95 will apply to cover the cost of return freight.*

This Limited Warranty is extended to the original purchaser of the unit and excludes all other legal, implied and/or conventional warranties. The responsibility of **SharkNinja Operating LLC** if any, is limited to the specific obligations expressly assumed by it under the terms of this Limited Warranty. In no event is **SharkNinja Operating LLC** liable for incidental or consequential damages to anyone of any nature whatsoever. Some states do not permit the exclusion or limitation of incidental or consequential damages, so the above may not apply to you.

This Limited Warranty gives you specific legal rights, and you may also have other rights which vary from state to state or from province to province.

***IMPORTANT: Carefully pack item to avoid damage in shipping. Be sure to include proof of purchase date and to attach tag to item before packing with your name, complete address and phone number with a note giving purchase information, model number and what you believe is the problem with the item. We recommend you insure the package (as damage in shipping is not covered by your Limited Warranty). Mark the outside of your package "ATTENTION CUSTOMER SERVICE".**

Product Registration

Please visit www.registeryourninja.com or call **1-877-646-5288** to register your new Ninja® product within ten (10) days of purchase. You will be asked to provide the store name, date of purchase and model number along with your name and address.

The registration will enable us to contact you in the unlikely event of a product safety notification. By registering you acknowledge to have read and understood the instructions for use, and warnings set forth in the accompanying instructions.



SharkNinja Operating LLC

US: Newton, MA 02459

CAN: Ville St-Laurent, QC H4S 1A7

1-877-646-5288

www.ninjakitchen.com

Copyright © SharkNinja Operating LLC 2016

Master Prep and **Ninja** are registered trademarks of SharkNinja Operating LLC.

Illustrations may differ from actual product. We are constantly striving to improve our products, therefore the specifications contained herein are subject to change without notice.

For SharkNinja U.S. Patent information visit www.sharkninja.com/USPatents.

Printed in China

QB1004_Series_30_161024_6