

**WARNING: PLEASE CAREFULLY READ THE SEPARATE HEALTH AND SAFETY PRECAUTIONS BOOKLET INCLUDED WITH THIS PRODUCT BEFORE USING YOUR NINTENDO® HARDWARE SYSTEM, GAME PAK OR ACCESSORY. THIS BOOKLET CONTAINS IMPORTANT HEALTH AND SAFETY INFORMATION.**

*The official seal is your assurance that this product is licensed or manufactured by Nintendo. Always look for this seal when buying video game systems, accessories, games and related products.*



Nintendo does not license the sale or use of products without the Official Nintendo Seal.®

- Pour une version française de ce manuel, veuillez aller sur le site [www.nintendo.com/consumer/manuals.html](http://www.nintendo.com/consumer/manuals.html) ou appeler le 1-800-255-3700.
- Para obtener la versión de este manual en español, visite nuestro web site a [www.nintendo.com/consumer/manuals.html](http://www.nintendo.com/consumer/manuals.html) o llame a 1-800-255-3700.

© 2004 Nintendo. All Rights Reserved.  
TM and ® are trademarks of Nintendo.

PN 50504B

NINTENDO DS

C/NTR-USA

**INSTRUCTION BOOKLET**

**1**

## Important Safety Information: Read The Following Warnings Before You Or Your Child Play Video Games

### **⚠ WARNING - Seizures**

- Some people (about 1 in 4000) may have seizures or blackouts triggered by light flashes or patterns, such as while watching TV or playing video games, even if they have never had a seizure before.
- Anyone who has had a seizure, loss of awareness, or other symptom linked to an epileptic condition should consult a doctor before playing a video game.
- Parents should watch when their children play video games. Stop playing and consult a doctor if you or your child have any of the following symptoms:

<b>Convulsions</b>	<b>Eye or muscle twitching</b>	<b>Loss of awareness</b>
<b>Altered vision</b>	<b>Involuntary movements</b>	<b>Disorientation</b>

- To reduce the likelihood of a seizure when playing video games:
  1. Sit or stand as far from the screen as possible.
  2. Play video games on the smallest available television screen.
  3. Do not play if you are tired or need sleep.
  4. Play in a well-lit room.
  5. Take a 10 to 15 minute break every hour.

### **⚠ WARNING - Repetitive Motion Injuries and Eyestrain**

Playing video games can make your muscles, joints, skin or eyes hurt after a few hours. Follow these instructions to avoid problems such as tendonitis, carpal tunnel syndrome, skin irritation or eyestrain:

- Avoid excessive play. It is recommended that parents monitor their children for appropriate play.
- Take a 10 to 15 minute break every hour, even if you don't think you need it.
- If your hands, wrists, arms or eyes become tired or sore while playing, stop and rest them for several hours before playing again.
- If you continue to have sore hands, wrists, arms or eyes during or after play, stop playing and see a doctor.

### **HARDWARE PRECAUTIONS / MAINTENANCE**

1. Do not disassemble or try to repair the NINTENDO DS or components. Doing so voids your warranty.
2. Always slide the power button of the NINTENDO DS off before loading or removing a Game Pak. Insert the Game Pak completely without forcing either the Game Pak or the NINTENDO DS.
3. Do not store the NINTENDO DS in a humid place, on the floor or in any location where it may collect dirt, dust, lint, etc.
4. Do not drop, hit or otherwise abuse the NINTENDO DS or components.
5. Make sure all connections to the NINTENDO DS are made carefully and inserted into the correct locations only. Hold plugs straight when inserting them into a socket.
6. When disconnecting any plugs from the NINTENDO DS or wall outlet, first turn the NINTENDO DS off. Then carefully pull by the plug itself rather than by the cord. Do not step on, sharply pull or bend any wires or cables.
7. Do not expose the NINTENDO DS, Game Paks or any of the NINTENDO DS components to extreme heat or cold. The liquid crystal display (LCD) may become slower or may not work when the temperature is low. The LCD will deteriorate at a high temperature. Take care not to expose the NINTENDO DS to direct sunlight for extended periods of time.
8. The LCD may be damaged by sharp objects or pressure. Take great care to protect the display from scratches or stains.

9. Connect **ONLY** special accessories designed for use with the NINTENDO DS to the AC ADAPTER Connector.
10. Do not spill liquids on the NINTENDO DS, Game Paks or any other of the NINTENDO DS components. To clean, use a soft slightly damp cloth. Allow the component to dry completely before using again. (Use water only.)
11. Do not rapidly turn the power switch on and off, as this may shorten the life of the batteries and cause battery backed-up Game Paks to lose your stored game information.
12. For the best game image, look directly at the NINTENDO DS display from the front and operate only in a good light.
13. To avoid dirt or dust from getting into the NINTENDO DS, always leave a Game Pak loaded (with the power off), when not in use.
14. When using an AC adapter, make sure you are using the correct model appropriate for your NINTENDO DS. Always unplug the AC adapter from the wall outlet when not in use.

### **GAME PAK PRECAUTIONS / MAINTENANCE**

1. Avoid touching the connectors with your fingers. Do not blow on them or allow them to get wet or dirty. Doing so may damage the Game Pak and/or the NINTENDO DS.
2. The Game Pak is a high precision piece of electronics. Do not store it in places that are very hot or cold. Do not hit, drop or otherwise abuse it. Do not take it apart.
3. Do not clean with benzene, paint thinner, alcohol or any other solvent.
4. Always check the Game Pak edge connector for foreign material before inserting the Game Pak into the NINTENDO DS. To prevent the edge connectors from becoming dirty, we recommend that you regularly use the NINTENDO DS Cleaning Wand. (Sold separately. Visit our on-line store at [www.nintendo.com](http://www.nintendo.com) or call 1-800-255-3700.)

### **Cautions Related to Wireless Functionality**

#### **COMPLIANCE WITH FCC REGULATIONS**

1. Do not use wireless multiplayer in crowded areas such as trains. Someone nearby may be using a heart pacemaker.
2. When you are using wireless multiplayer, keep at least 22cm from anyone who is using a heart pacemaker.
3. Turn the power OFF in areas where the use of electrical devices or wireless devices is prohibited, such as airports, hospitals and the like.
4. Using this machine in wireless multiplayer mode near equipment that is a source of radio interference (wireless LAN, micro wave ovens, cordless telephones, etc) could interfere with the operation of those devices.

#### **FCC Notice**

#### **COMPLIANCE WITH FCC REGULATIONS**

RF Radiation Exposure Statement:

In order to comply with FCC radio-frequency radiation exposure guidelines for an uncontrolled exposure, this device and its antenna must not be co-located or operating in conjunction with any other antenna or transmitter.

Under FCC rules, changes or modifications to this product not expressly approved by the manufacturer could void the user's authority to operate this product.

#### **IC Notice**

#### **COMPLIANCE WITH IC REGULATIONS**

Operation is subject to the following two conditions:(1) this device may not cause interference, and (2) this device must accept any interference, including interference that may cause undesired operation of the device.

The Term "IC:" before the certification/registration number only signifies that the Industry Canada technical specifications were met.

## 2 List of Components

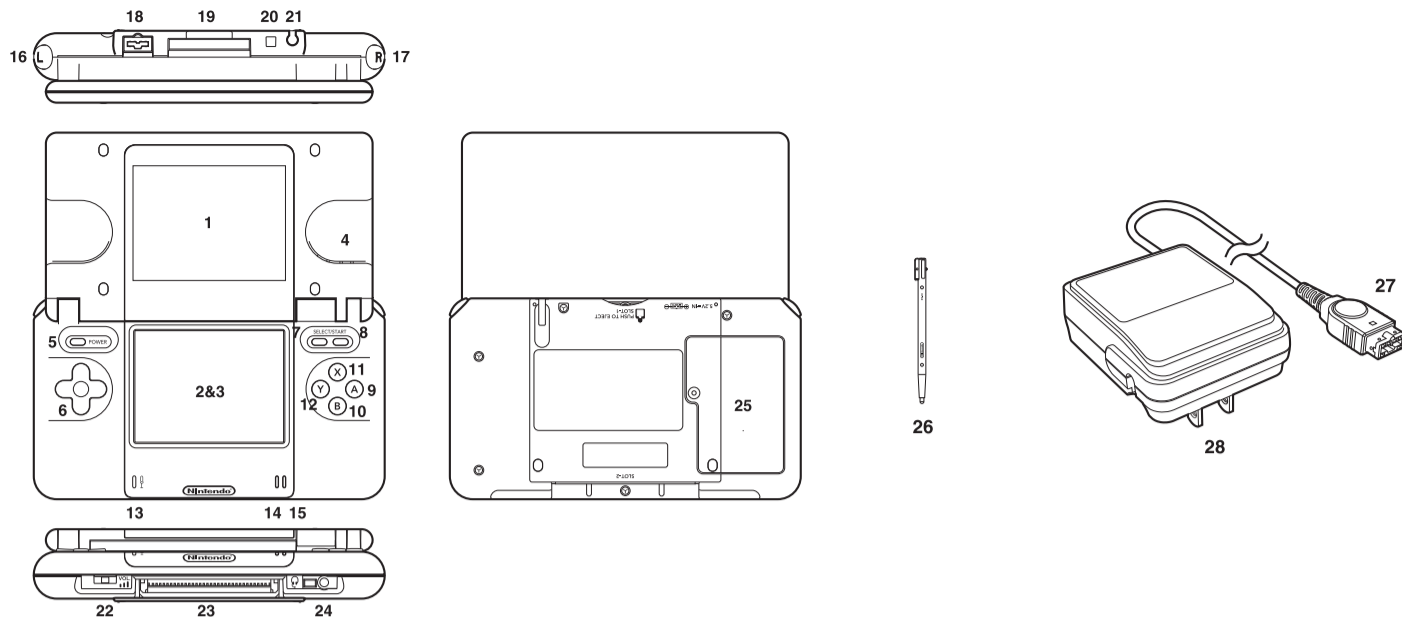

- |   |   |   |
|---|---|---|
| <ul style="list-style-type: none"> <li>1. Color LCD Screen</li> <li>2. Color LCD Screen(Touch Screen)</li> <li>3. Protect Sheet</li> <li>4. Speaker</li> <li>5. Power Button</li> <li>6. + Control Pad</li> <li>7. SELECT Button</li> <li>8. START Button</li> <li>9. A Button</li> <li>10. B Button</li> </ul> | <ul style="list-style-type: none"> <li>11. X Button</li> <li>12. Y Button</li> <li>13. MIC.</li> <li>14. Recharge Indicator LED</li> <li>15. Power Indicator LED</li> <li>16. L Button</li> <li>17. R Button</li> <li>18. AC ADAPTER Connector</li> <li>19. DS Game Pak Slot</li> <li>20. Wrist Strap Attachment</li> </ul> | <ul style="list-style-type: none"> <li>21. Touch Pen Holder</li> <li>22. Volume</li> <li>23. GBA Game Pak Slot</li> <li>24. Headphone / MIC. Connector</li> <li>25. Battery Cover</li> <li>26. Touch Pen</li> <li>27. DC Connector Plug</li> <li>28. AC Connector Prongs</li> </ul> |
|---|---|---|

## 3 Charging the NINTENDO DS Battery Pack

Do not use the NINTENDO DS AC Adapter during a lightning storm. There may be a risk of electric shock from lightning.

Before you use your NINTENDO DS for the first time, or after you have not used it for a long time, you must charge the rechargeable battery pack. (For optimal battery pack life, do not let the battery pack remain completely discharged for long periods of time.)

The rechargeable battery pack can be recharged approximately 500 times, but performance may decrease after repeated recharges, depending on usage conditions such as temperature. Battery life may also decrease over time. After 500 recharges, battery life may become only 70% of the battery life when new.

It takes approximately three hours to recharge the battery. (The actual recharge time varies depending on how much battery life you have left.) When the Power Indicator LED becomes red, save your game and recharge the battery to prevent game data loss. You can play games while recharging the battery, but the recharge time is longer when you do so.

**IMPORTANT:** The NINTENDO DS AC Adapter is only for use with the NINTENDO DS portable & Game Boy Advance SP video game system. It is not compatible with the original Game Boy, Game Boy pocket, Game Boy Color or original Game Boy Advance.

When you are finished playing, always turn your system OFF, and unplug the AC Adapter (if you are using it) from both the wall socket and NINTENDO DS. Do not wrap the AC Adapter cord around the NINTENDO DS.

1. Insert the AC Adapter's DC Connector Plug into **AC ADAPTER Connector** on the NINTENDO DS.

**IMPORTANT:** Be sure the DC Connector Plug is facing in the correct direction before inserting into **AC ADAPTER Connector** to avoid damaging the DC Connector Plug and/or the External Extension Connector.

2. Swing the prongs out of the AC Adapter and insert into a standard 120-volt AC wall outlet. **Be sure that the prongs are fully inserted into the outlet.**

The Recharge Indicator LED will light up. You can play games while charging, however it will take longer to recharge the battery. **The LED will turn OFF when the battery is fully charged.**

3. When fully charged, remove the AC Adapter from the wall outlet and fold the prongs back into the housing. Remove the DC Connector Plug from **AC ADAPTER Connector**. **When disconnecting any plugs from the NINTENDO DS or wall outlet, carefully pull by the plug itself rather than by the cord.**

## 4 Using the NINTENDO DS Video Game System

1. Insert a Game Pak into the DS Game Pak Slot or GBA Game Pak Slot on the underside of the NINTENDO DS.

**CAUTION:** Always check the Game Pak edge connector for foreign material before inserting the Game Pak into the NINTENDO DS.

2. Turn on the power by pushing the Power Switch towards the screen.

3. The screen will display the NINTENDO DS logo, and then change to the display for the game that you are playing. Be sure to read the Game Pak instruction booklet for the game you are playing.

4. To remove the Game Pak after playing, first turn the power OFF by sliding the Power Switch towards the front, then slide the Game Pak out of the DS Game Pak Slot or GBA Game Pak Slot.

5. When finished playing, fold the NINTENDO DS closed to protect the display screen. Note: The power does not automatically turn off when the system is folded closed.

## 5 Multiplayer Game Play Using NINTENDO DS Game Paks

### Things to prepare:

Nintendo DS : the same number of pieces as players  
Game Software : the same number of pieces as players

### How to play:

1. Make sure that all Nintendo DS systems are powered off, then insert a game cartridge into the systems.
2. Turn on the power for all the systems.
3. Follow the instruction in Game Pak manual.

### Cautions for Wireless Play:

For better communication, please follow the guidelines below:

- Keep the distance among Nintendo DS systems within 3m.
- Keep the Nintendo DS systems facing each other.
- Make sure that there is no obstacles between the Nintendo DS systems.
- Don't use the Nintendo DS systems near some RF equipment such as wireless LAN, microwave, codeless equipment which may cause interference to the system.
- A group of people who are playing Wireless Play may cause interference to other groups each other so that the communication may not work smoothly. In this case, please stay away from other groups.
- Playing with the number of players exceeds the numbers specified in a game may disturb the communication. Please follow the number of players specified in a game.

