



FastMile 2.1.06

Nokia FastMile 4G Receiver Product Overview

3TG-00386-ABGA-TCZZA

Issue: DRAFT

August 2020

Nokia is a registered trademark of Nokia Corporation. Other products and company names mentioned herein may be trademarks or tradenames of their respective owners.

The information presented is subject to change without notice. No responsibility is assumed for inaccuracies contained herein.

© 2020 Nokia.

Contains proprietary/trade secret information which is the property of Nokia and must not be made available to, or copied or used by anyone outside Nokia without its written authorization. Not to be used or disclosed except in accordance with applicable agreements.

1 Preface

This preface provides general information about the Product Overview for the Nokia FastMile 4G Receiver.

1.1 Summary of document issue changes

Changes between document issues are cumulative. Therefore, the latest document issue contains all changes made to previous issues.

Issue 01: first issue of the document for this release of the FastMile 4G Receiver

1.2 Scope

This document provides an overview of the Nokia FastMile 4G Receiver along with information about safety and troubleshooting the Nokia FastMile 4G Receiver.

1.3 Audience

This document is intended for planners, administrators, operators, and maintenance personnel involved in installing, upgrading, or maintaining the Nokia FastMile 4G Receiver.

1.4 Required knowledge

The reader must be familiar with general telecommunications principles.

1.5 Acronyms and initialisms

The expansions and optional descriptions of most acronyms and initialisms used in this document appear in the glossary at the back of the document.

1.6 Assistance and ordering phone numbers

Nokia provides global technical support through the following URL:
<https://customer.nokia.com/support/s/>.

For ordering information, contact your Nokia sales representative.

1.7 Nokia quality processes

Nokia's FastMile 4G Receiver quality practices are in compliance with TL 9000 requirements. These requirements are documented in the Fixed Networks Quality Manual 3FQ-30146-6000-QRZZA. The quality practices adequately ensure that technical requirements and customer end-point requirements are met. The customer or its representatives may be allowed to perform on-site quality surveillance audits, as agreed upon during contract negotiations.

1.8 Safety information

For safety information, see the appropriate safety guideline chapters.

1.9 Documents

Documents are available at the Nokia Documentation Center.

Procedure 1 To access a document on the Nokia Documentation Center

Individual PDFs of customer documents are accessible through the Nokia Documentation Center.

-
- 1 Go to <https://documentation.nokia.com>
Log in as required.

 - 2 Enter FastMile 4G Receiver in the Product box.

 - 3 Select the search criteria as needed (Release, Content Type, Sort by, etc.) and Click on Search.

 - 4 Click on the PDF icon to access a document.
-

1.10 Special information

The following are examples of how special information is presented in this document.



Danger — Danger indicates that the described activity or situation may result in serious personal injury or death; for example, high voltage or electric shock hazards.



Warning — Warning indicates that the described activity or situation may, or will, cause equipment damage or serious performance problems.



Caution — Caution indicates that the described activity or situation may, or will, cause service interruption.



Note — A note provides information that is, or may be, of special interest.

1.10.1 Steps with options or substeps

When there are options in a step, they are identified by letters. When there are required substeps in a step, they are identified by roman numerals.

Procedure 2 Example of options in a step

At step 1, you must choose option a or b.

1 This step offers two options. You must choose one of the following:

- a This is one option.
- b This is another option.

2 You must perform this step.

Procedure 3 Example of required substeps in a step

At step 1, you must perform a series of substeps within the step.

-
- 1 This step has a series of substeps that you must perform to complete the step. You must perform the following substeps:
 - i This is the first substep.
 - ii This is the second substep.
 - iii This is the third substep.
 - 2 You must perform this step.
-

1.11 Multiple PDF document search

You can use Adobe Reader Release 6.0 and later to search multiple PDF files for a common term. Adobe Reader displays the results in a single display panel. The results are grouped by PDF file, and you can expand the entry for each file.



Note — The PDF files in which you search must be in the same folder.

Procedure 4 To search multiple PDF files for a common term

-
- 1 Open Adobe Acrobat Reader.
 - 2 Choose Edit→Search from the Acrobat Reader main menu. The Search PDF panel appears.
 - 3 Enter the search criteria.
 - 4 Click on the All PDF Documents In radio button.
 - 5 Select the folder in which to search using the drop-down menu.
 - 6 Click on the Search button.
-

Acrobat Reader displays the search results. You can expand the entries for each document by clicking on the + symbol.

Table of contents

1	Preface	3
1.1	Summary of document issue changes	3
1.2	Scope	3
1.3	Audience.....	3
1.4	Required knowledge.....	3
1.5	Acronyms and initialisms	3
1.6	Assistance and ordering phone numbers	3
1.7	Nokia quality processes.....	4
1.8	Safety information.....	4
1.9	Documents	4
1.10	Special information	5
1.10.1	Steps with options or substeps.....	5
1.11	Multiple PDF document search	6
2	ETSI environmental and CRoHS guidelines	19
2.1	Environmental labels	19
2.1.1	Overview.....	19
2.1.2	Environmental related labels	19
2.1.2.1	Products below Maximum Concentration Value (MCV) label.....	19
2.1.2.2	Products containing hazardous substances above Maximum Concentration Value (MCV) label.....	20
2.2	Hazardous Substances Table (HST).....	21
2.3	Other environmental requirements	21
2.3.1	Environmental requirements.....	22
2.3.2	Storage	22
2.3.3	Transportation	22
2.3.4	Stationary use.....	22
2.3.5	Thermal limitations	22
2.3.6	Material content compliance.....	23
2.3.7	End-of-life collection and treatment.....	23
2.4	Additional information	24
3	ETSI safety guidelines	25
3.1	Safety instructions	25
3.1.1	Safety instruction boxes	25
3.1.2	Safety-related labels.....	26
3.2	Safety standards compliance	26
3.2.1	EMC compliance	27
3.2.2	Equipment safety standard compliance.....	27
3.2.3	Environmental standard compliance	27
3.2.4	Laser product standard compliance	27
3.3	Electrical safety guidelines	28
3.3.1	Power supplies	28
3.3.2	Cabling	28
3.3.3	Protective earth	28
3.4	ESD safety guidelines	29

3.5	Environmental requirements.....	29
3.6	Additional information	29
4	ANSI safety guidelines	31
4.1	Safety instructions	31
4.1.1	Safety instruction boxes in customer documentation	31
4.1.2	Safety-related labels.....	32
4.2	Safety standards compliance	33
4.2.1	EMC, EMI, and ESD compliance.....	34
4.2.2	Equipment safety standard compliance.....	34
4.3	Electrical safety guidelines	35
4.3.1	Power supplies	35
4.3.2	Cabling	35
4.3.3	Protective earth	35
4.4	ESD safety guidelines	36
4.5	Environmental requirements.....	36
4.6	Additional information	36
5	Product overview.....	37
5.1	Overview of the Nokia FastMile 4G Receiver.....	37
5.2	End-to-end example	39
5.3	Installing the Nokia FastMile 4G Receiver.....	40
6	Functional overview	41
6.1	Overview.....	41
6.1.1	Nokia Wireless app.....	41
6.1.2	Web UI.....	42
6.1.3	Remote management.....	43
6.2	LTE characteristics	43
6.3	Data forwarding	44
6.4	Ethernet characteristics	45
6.5	Power supply characteristics	45
6.6	Remote management protocols	46
7	Model overview	49
7.1	Models of the Nokia FastMile 4G Receiver	49
7.1.1	Label information	51
8	Physical interfaces	53
8.1	Physical interfaces of the Compact mono-band and ABA models	53
8.2	Physical interfaces of the Compact multi-band models.....	54
9	SIM cards.....	57
9.1	SIM card information for the Compact mono-band and ABA models.....	57
9.2	SIM card information for the Compact multi-band models	58
10	LEDs.....	59
10.1	Status LED	59
10.2	Signal strength LEDs	61
11	Power information	63
11.1	Power information for the Nokia FastMile 4G Receiver	63
11.2	Available PoE injectors.....	63

12	Performance information	67
12.1	Performance overview.....	67
12.2	Throughput information	67
12.3	Carrier aggregation information.....	68
12.4	Power consumption information	82
13	Management using the Nokia Wireless app	83
13.1	Using the Nokia Wireless app to manage the Nokia FastMile 4G Receiver	83
13.2	Using the Nokia Wireless app to manage a unit managed by the Nokia Altiplano FastMile Controller	86
13.3	Using the Nokia Wireless app to manage a unit managed by an ACS	104
14	Management using the Web UI.....	125
14.1	Using the Web UI to manage the Nokia FastMile 4G Receiver.....	125
14.2	Using the Web UI status screen	125
14.3	Using the Web UI network screen	131
14.4	Using the Web UI CBRS screen.....	142
14.5	Using the Web UI system screen	143
15	Standards certification	151
15.1	Standards certification for Compact mono-band and ABA models	151
15.2	Standards certification for the Compact multi-band models	152
16	Appendix A: Specifications	153
16.1	Specifications	153
17	Appendix B: RF exposure	155
17.1	RF exposure	155
18	Appendix C: FCC statements and label instructions	157
18.1	FCC compliance statement	157
18.2	FCC radiation exposure statement.....	158
18.3	FCC label instructions	158
19	Glossary	159

List of figures

2	ETSI environmental and CRoHS guidelines	19
Figure 1	Products below MCV value label.....	20
Figure 2	Products above MCV value label	21
Figure 3	Recycling/take back/disposal of product symbol	23
4	ANSI safety guidelines	31
Figure 4	Sample safety label for FCC.....	33
Figure 5	Sample safety label for ETL	33
5	Product overview	37
Figure 6	Application example of the Nokia FastMile 4G Receiver.....	38
Figure 7	Examples of model types of the Nokia FastMile 4G Receiver.....	39
Figure 8	End-to-end example featuring the Nokia FastMile 4G Receiver with a residential gateway and PoE injector	40
6	Functional overview	41
Figure 9	Remote management of the Nokia FastMile 4G Receiver through the Nokia Altiplano FastMile Controller	47
Figure 10	Remote management of the Nokia FastMile 4G Receiver through an ACS	48
8	Physical interfaces	53
Figure 11	Location of physical interfaces on the Compact mono-band and ABA models of the Nokia FastMile 4G Receiver	54
Figure 12	Location of the ground point for the Compact multi-band models of the Nokia FastMile 4G Receiver.....	56
Figure 13	Location of physical interfaces on the underside of the Compact multi-band models of the Nokia FastMile 4G Receiver	56
9	SIM cards	57
Figure 14	Detailed view of SIM card slot on the Compact mono-band and ABA models.....	57
Figure 15	Detailed view of SIM card slot on the Compact multi-band models	58
10	LEDs	59
Figure 16	Location of the status LED on the Compact mono-band and ABA models of the Nokia FastMile 4G Receiver	59
Figure 17	Location of the status LED on the Compact multi-band models of the Nokia FastMile 4G Receiver.....	59
Figure 18	Location of the signal strength LEDs.....	61
Figure 19	Location of the measurement button	61
13	Management using the Nokia Wireless app	83
Figure 20	Before we begin screen.....	84
Figure 21	Terms of Service screen.....	85
Figure 22	Introductory screen for unit managed by the Nokia Altiplano FastMile Controller through NETCONF	87
Figure 23	Screen with prompt to scan the QR code for unit managed by the Nokia Altiplano FastMile Controller through NETCONF	88

Figure 24	QR code screen for unit managed by the Nokia Altiplano FastMile Controller through NETCONF	89
Figure 25	Screen showing the Already Installed option for unit managed by the Nokia Altiplano FastMile Controller through NETCONF	90
Figure 26	Screen for connecting to the Nokia FastMile 4G Receiver	91
Figure 27	Screen for enabling the VPN profile	92
Figure 28	Prompt for accepting the connection request	93
Figure 29	Screen to log in to a Nokia FastMile 4G Receiver managed by the Nokia Altiplano FastMile Controller	94
Figure 30	System state screen example for a Nokia FastMile 4G Receiver managed by the Nokia Altiplano FastMile Controller	96
Figure 31	System state screen with Beam Angle information for a Nokia FastMile 4G Receiver managed by the Nokia Altiplano FastMile Controller .	97
Figure 32	Screen that has the “Upload CA certificates” option for a Nokia FastMile 4G Receiver managed by the Nokia Altiplano FastMile Controller .	98
Figure 33	Screen that lists the CA certificates for a Nokia FastMile 4G Receiver managed by the Nokia Altiplano FastMile Controller	99
Figure 34	Screen indicating that uploading of the CA certificates was successful for a Nokia FastMile 4G Receiver managed by the Nokia Altiplano FastMile Controller	100
Figure 35	Screen showing the “Reboot Device” option for a Nokia FastMile 4G Receiver managed by the Nokia Altiplano FastMile Controller	101
Figure 36	Screen showing the reboot message for a Nokia FastMile 4G Receiver managed by the Nokia Altiplano FastMile Controller	102
Figure 37	Screen showing the “Perform Factory Reset” option for a Nokia FastMile 4G Receiver managed by the Nokia Altiplano FastMile Controller .	103
Figure 38	Screen showing the factory reset message for a Nokia FastMile 4G Receiver managed by the Nokia Altiplano FastMile Controller	104
Figure 39	Introductory screen for unit managed by an ACS through TR-069	106
Figure 40	Screen with prompt to scan the QR code for unit managed by an ACS through TR-069	107
Figure 41	QR code screen for unit managed by an ACS through TR-069	108
Figure 42	Screen showing the Already Installed option for unit managed by an ACS through TR-069	109
Figure 43	Screen for connecting to the Nokia FastMile 4G Receiver	110
Figure 44	Screen for enabling the VPN profile	111
Figure 45	Prompt for accepting the connection request	112
Figure 46	Screen to log in to a Nokia FastMile 4G Receiver managed by an ACS through TR-069	113
Figure 47	System state screen example for a Nokia FastMile 4G Receiver managed by an ACS through TR-069	115
Figure 48	System state screen with Beam Angle information for a Nokia FastMile 4G Receiver managed by an ACS through TR-069	116
Figure 49	Screen that has the “Upload CA certificates” option for a Nokia FastMile 4G Receiver managed by an ACS through TR-069	117

Figure 50	Upload CA Certificates screen for a Nokia FastMile 4G Receiver managed by an ACS through TR-069	118
Figure 51	List of CA certificates displayed on the Upload CA Certificates screen for a Nokia FastMile 4G Receiver managed by an ACS through TR-069.....	119
Figure 52	Screen showing that upload of CA certificates was successful for a Nokia FastMile 4G Receiver managed by an ACS through TR-069	121
Figure 53	Screen showing the “Reboot Device” option for a Nokia FastMile 4G Receiver managed by an ACS through TR-069	122
Figure 54	Screen showing the “Perform Factory Reset” option for a Nokia FastMile 4G Receiver managed by ACS through TR-069.....	123
Figure 55	Screen showing the factory reset message for a Nokia FastMile 4G Receiver managed by ACS through TR-069	124
14	Management using the Web UI.....	125
Figure 56	Example of the top part of the Status screen when the FastMile 4G Receiver is not connected to a cell.....	127
Figure 57	Example of the lower part of the Status screen without available cells when the FastMile 4G Receiver is not connected to a cell.....	127
Figure 58	Example of the lower part of the Status screen with available cells when the FastMile 4G Receiver is not connected to a cell.....	128
Figure 59	Example of the top part of the Status screen when the FastMile 4G Receiver is connected to a cell.....	128
Figure 60	Example of a lower part of the Status screen when the FastMile 4G Receiver is connected to a cell.....	129
Figure 61	Example of the Trigger Measurement pop up window	129
Figure 62	Example of ongoing Trigger Measurement	130
Figure 63	Example of Trigger Measurement completed and FastMile 4G Receiver is detached.....	130
Figure 64	Example of Trigger Measurement completed and FastMile 4G Receiver is reattached.....	131
Figure 65	Example of the lowest part of the Status screen when the FastMile 4G Receiver is connected to a cell	131
Figure 66	Example of the Login screen	133
Figure 67	Example of the Network screen.....	134
Figure 68	Example of scroll down for the Network screen	134
Figure 69	Example of the Add Access Point window	135
Figure 70	Example of the Delete Access Point window	136
Figure 71	Example of the Edit Location window	137
Figure 72	Example of the Edit Controller window.....	138
Figure 73	Example of the Edit Connection Request window	139
Figure 74	Example of the Edit DHCP window	140
Figure 75	Example of the Certificates information window.....	141
Figure 76	Example of the Add Cell window	141
Figure 77	Example of the Delete Cell window	142
Figure 78	Example of the Web UI CBRS screen	143
Figure 79	Example of the System screen.....	144
Figure 80	Example of the Restart Device confirmation window	145
Figure 81	Example of the Restore Device confirmation window	146

Figure 82 Example of the screen that displays while firmware is being uploaded..... 147

Figure 83 Example of the screen that displays while firmware is being upgraded 148

Figure 84 Example of the screen that displays while the system is being rebooted 149

List of tables

3	ETSI safety guidelines	25
Table 1	Safety labels	26
4	ANSI safety guidelines	31
Table 2	Safety labels	32
6	Functional overview	41
Table 3	E-UTRA bands supported by the Nokia FastMile 4G Receiver	43
Table 4	Data forwarding methods supported by the Nokia FastMile 4G Receiver	44
7	Model overview	49
Table 5	Models of the Nokia FastMile 4G Receiver	49
Table 6	Label information for the Nokia FastMile 4G Receiver	51
8	Physical interfaces	53
Table 7	Physical interfaces of the Compact mono-band and ABA models of the Nokia FastMile 4G Receiver	53
Table 8	Physical interfaces of the Compact multi-band models of the Nokia FastMile 4G Receiver	54
10	LEDs	59
Table 9	Status LED behavior for Nokia FastMile 4G Receiver managed from the Nokia Altiplano FastMile Controller	60
Table 10	Status LED behavior for Nokia FastMile 4G Receiver managed from an ACS	60
Table 11	Signal strength LED threshold values	62
11	Power information	63
Table 12	Available PoE injectors for Model 4G05-B	64
Table 13	Available PoE injectors for Model 4G17-A	64
Table 14	Available PoE injectors for models other than Model 4G05-B and Model 4G17-A	65
12	Performance information	67
Table 15	LTE throughput information	67
Table 16	Carrier aggregation support for Model 4G01-A and Model 4G01-B (2*2 MIMO downlink with SISO uplink).....	69
Table 17	Carrier aggregation support for Model 4G02-A (2*2 MIMO downlink with SISO uplink)	71
Table 18	Carrier aggregation support for Model 4G03-A (2*2 MIMO downlink with SISO uplink)	71
Table 19	Carrier aggregation support for Model 4G04-A (2*2 MIMO downlink with SISO uplink)	73
Table 20	Carrier aggregation support for Model 4G05-A and Model 4G05-B (2*2 MIMO downlink).....	73
Table 21	Carrier aggregation support for Model 4G06-A (2*2 MIMO downlink)	77

Table 22	Carrier aggregation support for Model 4G17-A (2*2 MIMO downlink with SISO uplink).....	81
Table 23	Power consumption information for all models.....	82
15	Standards certification.....	151
Table 24	Standards certifications for the Nokia FastMile 4G Receiver Compact mono-band and ABA models	151
Table 25	Standards certifications for the Nokia FastMile 4G Receiver Compact multi-band models.....	152
16	Appendix A: Specifications	153
Table 26	Specifications for the Nokia FastMile 4G Receiver	153
17	Appendix B: RF exposure.....	155
Table 27	RF exposure distances.....	155
18	Appendix C: FCC statements and label instructions	157
Table 28	FCC ID for Nokia FastMile 4G Receiver.....	157

2 ETSI environmental and CRoHS guidelines

This chapter provides information about the ETSI environmental China Restriction of Hazardous Substances (CRoHS) regulations that govern the installation and operation of Nokia FastMile 4G Receiver equipment. This chapter also includes environmental operation parameters of general interest.

2.1 Environmental labels

This section describes the environmental instructions that are provided with the customer documentation, equipment, and location where the equipment resides.

2.1.1 Overview

CRoHS is applicable to Electronic Information Products (EIP) manufactured or sold and imported in the territory of the mainland of the People's Republic of China. EIP refers to products and their accessories manufactured by using electronic information technology, including electronic communications products and such subcomponents as batteries and cables.

2.1.2 Environmental related labels

Environmental labels are located on appropriate equipment. The following are sample labels.

2.1.2.1 Products below Maximum Concentration Value (MCV) label

Figure 1 shows the label that indicates a product is below the maximum concentration value, as defined by standard SJ/T11363-2006 (Requirements for Concentration Limits for Certain Hazardous Substances in Electronic Information Products). Products with this label are recyclable. The label may be found in this documentation or on the product.

Figure 1 Products below MCV value label



18986

2.1.2.2 Products containing hazardous substances above Maximum Concentration Value (MCV) label

Figure 2 shows the label that indicates a product is above the maximum concentration value, as defined by standard SJ/T11363-2006 (Requirements for Concentration Limits for Certain Hazardous Substances in Electronic Information Products). The number contained inside the label indicates the Environment-Friendly User Period (EFUP) value. The label may be found in this documentation or on the product.

Figure 2 Products above MCV value label

18985

Together with major international telecommunications equipment companies, Nokia has determined it is appropriate to use an EFUP of 50 years for network infrastructure equipment and an EFUP of 20 years for handsets and accessories. These values are based on manufacturers' extensive practical experience of the design, manufacturing, maintenance, usage conditions, operating environments, and physical condition of infrastructure and handsets after years of service. The values reflect minimum values and refer to products operated according to the intended use conditions. See "[Hazardous Substances Table \(HST\)](#)" for more information.

2.2 Hazardous Substances Table (HST)

This section describes the compliance of the Nokia FastMile 4G Receiver equipment to the CRoHS standard when the product and subassemblies contain hazardous substances beyond the MCV value. This information is found in this user documentation where part numbers for the product and subassemblies are listed. It may be referenced in other documentation that describes the Nokia FastMile 4G Receiver equipment.

In accordance with the People's Republic of China Electronic Industry Standard Marking for the Control of Pollution Caused by Electronic Information Products (SJ/T11364-2006), customers may access the Nokia Hazardous Substance Table, in Chinese, by contacting their Nokia representative.

2.3 Other environmental requirements

Observe the following environmental requirements when handling Nokia FastMile 4G Receiver equipment.

2.3.1 Environmental requirements

See chapter 16 in this document for more information about temperature ranges for the Nokia FastMile 4G Receiver equipment and other Nokia FastMile 4G Receiver specifications.

2.3.2 Storage

According to ETS 300-019-1-1 - Class 1.1, storage of Nokia FastMile 4G Receiver equipment must be in Class 1.1, weather-protected, temperature-controlled locations.

2.3.3 Transportation

According to EN 300-019-1-2 - Class 2.3, transportation of Nokia FastMile 4G Receiver equipment must be in packed, public transportation.

2.3.4 Stationary use

According to EN 300-019-1-3 - Class 3.1/3.2/3.E, stationary use of Nokia FastMile 4G Receiver equipment must be in a temperature-controlled location with no condensation allowed.

2.3.5 Thermal limitations

The thermal limitations for the Nokia FastMile 4G Receiver equipment are:

- operating temperature (ambient):
 - Compact mono-band and ABA models: -30°C to 65°C (-22°F to 149°F)
 - Compact multi-band models: -30°C to 55°C (-22°F to 131°F); Model 4G05-B: -40°C to 55°C (-40°F to 131°F)
- Humidity: 5% to 95% non condensing

2.3.6 Material content compliance

European Union (EU) Directive 2002/95/EC, “Restriction of the use of certain Hazardous Substances” (RoHS), restricts the use of lead, mercury, cadmium, hexavalent chromium, and certain flame retardants in electrical and electronic equipment. This Directive applies to electrical and electronic products placed on the EU market after 1 July 2006, with various exemptions, including an exemption for lead solder in network infrastructure equipment. Nokia products shipped to the EU after 1 July 2006 comply with the EU RoHS Directive.

Nokia has implemented a material/substance content management process. The process is described in: Nokia process for ensuring RoHS Compliance (1AA002660031ASZZA). This ensures compliance with the European Union Directive 2011/65/EU on the Restriction of the Use of Certain Hazardous Substances in Electrical and Electronic Equipment (RoHS2). With the process equipment is assessed in accordance with the Harmonised Standard EN50581:2012 (CENELEC) on Technical documentation for the assessment of electrical and electronic products with respect to the restriction of hazardous substances.

2.3.7 End-of-life collection and treatment

Electronic products bearing or referencing the symbol shown in Figure 3, when put on the market within the European Union (EU), shall be collected and treated at the end of their useful life, in compliance with applicable EU and local legislation. They shall not be disposed of as part of unsorted municipal waste. Due to materials that may be contained in the product, such as heavy metals or batteries, the environment and human health may be negatively impacted as a result of inappropriate disposal.

Figure 3 Recycling/take back/disposal of product symbol



At the end of its life, Nokia FastMile 4G Receiver equipment is subject to the applicable local legislations that implement the European Directive 2012/19EU on waste electrical and electronic equipment (WEEE).

There can be different requirements for collection and treatment in different member states of the European Union.

In compliance with legal requirements and contractual agreements, where applicable, Nokia will offer to provide for the collection and treatment of Nokia products bearing the logo shown in Figure 3 at the end of their useful life, or products displaced by Nokia equipment offers. For information regarding take-back of equipment by Nokia, or for more information regarding the requirements for recycling/disposal of product, contact your Nokia account manager or Nokia take back support at sustainability.global@nokia.com.

2.4 Additional information

See chapter 17 for RF exposure information.

3 ETSI safety guidelines

This chapter provides information about the mandatory regulations that govern the installation and operation of Nokia FastMile 4G Receiver equipment in the ETSI market.

3.1 Safety instructions

This section describes the safety instructions that are provided in the customer documentation and on the Nokia FastMile 4G Receiver equipment.

3.1.1 Safety instruction boxes

The safety instruction boxes are provided in the Nokia FastMile 4G Receiver customer documentation. Observe the instructions to meet safety requirements.

The following is an example of the Danger box.



Danger — Possibility of personal injury.

The Danger box indicates that the described activity or situation may pose a threat to personal safety. It calls attention to a situation or procedure which, if not correctly performed or adhered to, may result in death or serious physical harm.

Do not proceed beyond a Danger box until the indicated conditions are fully understood and met.

The following is an example of the Warning box.



Warning 1 — Possibility of equipment damage.

Warning 2 — Possibility of data loss.

The Warning box indicates that the described activity or situation may, or will, cause equipment damage, loss of data, or serious performance problems. It identifies a possible equipment-damaging situation or provides essential information to avoid the degradation of system operations or data.

Do not proceed beyond a warning until the indicated conditions are fully understood and met.

The following is an example of the Caution box.



Caution 1 — Possibility of service interruption.

Caution 2 — Service interruption.

The Caution box indicates that the described activity or situation may, or will, cause service interruption.

Do not proceed beyond a caution until the indicated conditions are fully understood and met.

The following is an example of the Note box.



Note — Information of special interest.

The Note box provides information that assists the personnel working with Nokia FastMile 4G Receiver equipment. It does not provide safety-related instructions.

3.1.2 Safety-related labels

The Nokia FastMile 4G Receiver equipment is labeled with the specific safety instructions and compliance information that is related to a product, or product variant or model, of the equipment. Observe the instructions on the safety labels.

Table 1 provides sample safety labels on Nokia FastMile 4G Receiver equipment.

Table 1 Safety labels

Description	Label text
ESD warning	Caution: This assembly contains an electrostatic sensitive device.

3.2 Safety standards compliance

This section describes Nokia FastMile 4G Receiver equipment compliance with the European safety standards.

3.2.1 EMC compliance

The Nokia FastMile 4G Receiver equipment complies with the following EMC requirements:

- Electromagnetic Compatibility (EMC) standard for radio equipment and services; Part 52: Specific conditions for Cellular Communication Mobile and portable (UE) radio and ancillary equipment; Harmonised Standard covering the essential requirements of article 3.1(b) of Directive 2014/53/EU
- Electromagnetic Compatibility (EMC) standard for radio equipment and services; Part 1: Common technical requirements; Harmonized Standard covering the essential requirements of article 3.1(b) of Directive 2014/53/EU and the essential requirements of article 6 of Directive 2014/30/EU EN 301489-1
- Electromagnetic Compatibility (EMC) standard for radio equipment and services; Part 17: Specific conditions for Broadband Data Transmission Systems; Harmonized Standard covering the essential requirements of article 3.1(b) of Directive 2014/53/EU EN 301489-17

3.2.2 Equipment safety standard compliance

The Nokia FastMile 4G Receiver equipment complies with the requirements of the following:

- EN 60950-1, Safety of Information Technology Equipment for use in a restricted location (per R-269)
- IEC 60950-22, EN 60950-22: Information Technology Equipment- Safety - Part 22 Equipment to be installed Outdoors
- IEC 62368 Audio/video, information and communication technology equipment- Part 1: Safety requirements
- IEC 60529 Degrees of protection provided by enclosures (IP Code)

3.2.3 Environmental standard compliance

The Nokia FastMile 4G Receiver equipment complies with the EN 300 019 European environmental standards.

3.2.4 Laser product standard compliance

The Nokia FastMile 4G Receiver equipment is not a laser product.

3.3 Electrical safety guidelines

This section provides the electrical safety guidelines for the Nokia FastMile 4G Receiver equipment.



Note 1 — The Nokia FastMile 4G Receiver equipment complies with the U.S. National Electrical Code. However, local electrical authorities have jurisdiction when there are differences between the local and U.S. standards.

Note 2 — The Nokia FastMile 4G Receiver equipment complies with BS EN 61140.

3.3.1 Power supplies

The use of any non-Nokia approved power supplies or power adapters is not supported or endorsed by Nokia. Such use will void any warranty or support contract with Nokia. Such use greatly increases the danger of damage to equipment or property.

3.3.2 Cabling

The following are the guidelines regarding cables used for the Nokia FastMile 4G Receiver equipment:

- All cables must be approved by the relevant national electrical code.
- Cables for outdoor connection to the Nokia FastMile 4G Receiver equipment must be suitable for outdoor use.
- The Nokia FastMile 4G Receiver equipment must be used with the cabling supplied with the equipment.

3.3.3 Protective earth

Earthing and bonding of the Nokia FastMile 4G Receiver equipment must comply with the requirements of local electrical codes.

3.4 ESD safety guidelines

The Nokia FastMile 4G Receiver equipment is sensitive to ESD if opened. Operations personnel must observe the following ESD instructions when they handle the Nokia FastMile 4G Receiver equipment.



Caution — This equipment is ESD sensitive if opened. Proper ESD protections should be used if you open the Nokia FastMile 4G Receiver.

Service personnel are not required to wear wrist straps when performing normal installation or maintenance activities.

3.5 Environmental requirements

See chapter 16 in this document for information about temperature ranges for the Nokia FastMile 4G Receiver equipment and other Nokia FastMile 4G Receiver specifications.

During operation in the supported temperature range, condensation inside the Nokia FastMile 4G Receiver equipment caused by humidity is not an issue because the Nokia FastMile 4G Receiver is a sealed unit.

3.6 Additional information

See chapter 17 for RF exposure information.

4 ANSI safety guidelines

This chapter provides information about the mandatory regulations that govern the installation and operation of the Nokia FastMile 4G Receiver equipment in the North American or ANSI market.

4.1 Safety instructions

This section describes the safety instructions that are provided in the customer documentation and on the Nokia FastMile 4G Receiver equipment.

4.1.1 Safety instruction boxes in customer documentation

The safety instruction boxes are provided in the Nokia FastMile 4G Receiver customer documentation. Observe the instructions to meet safety requirements.

The following is an example of the Danger box.



Danger — Possibility of personal injury.

The Danger box indicates that the described activity or situation may pose a threat to personal safety. It calls attention to a situation or procedure which, if not correctly performed or adhered to, may result in death or serious physical harm.

Do not proceed beyond a Danger box until the indicated conditions are fully understood and met.

The following is an example of the Warning box.



Warning 1 — Possibility of equipment damage.

Warning 2 — Possibility of data loss.

The Warning box indicates that the described activity or situation may, or will, cause equipment damage, loss of data, or serious performance problems. It identifies a possible equipment-damaging situation or provides essential information to avoid the degradation of system operations or data.

Do not proceed beyond a warning until the indicated conditions are fully understood and met.

The following is an example of the Caution box.



Caution 1 — Possibility of service interruption.

Caution 2 — Service interruption.

The Caution box indicates that the described activity or situation may, or will, cause service interruption.

Do not proceed beyond a caution until the indicated conditions are fully understood and met.

The following is an example of the Note box.



Note — Information of special interest.

The Note box provides information that assists the personnel working with Nokia FastMile 4G Receiver equipment. It does not provide safety-related instructions.

4.1.2 Safety-related labels

The Nokia FastMile 4G Receiver equipment is labeled with specific safety compliance information and instructions that are related to a product, or product model, of the equipment. Observe the instructions on the safety labels.

Table 2 provides examples of the text in the various Nokia FastMile 4G Receiver equipment safety labels.

Table 2 Safety labels

Description	Label text
UL compliance	ETL/cETL
UL50E compliance	Type 3
ESD warning	Caution: This assembly contains electrostatic sensitive device.
FCC standards compliance	Tested to comply with FCC standards for home or office use.
Operation conditions	This device complies with Part 15 of the FCC Rules. Operation is subject to the following two conditions: (1) this device may not cause harmful interference, and (2) this device must accept any interference received, including interference that may cause undesired operation.
CE marking	There are various CE symbols for CE compliance.

Figure 4 shows a sample safety label for FCC and Figure 5 shows a sample safety label for ETL.

Figure 4 Sample safety label for FCC

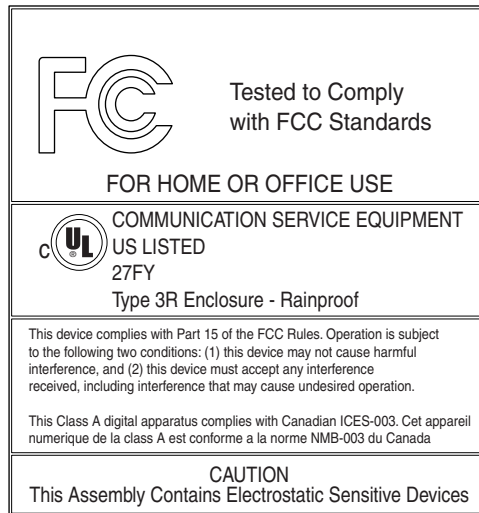

18533

Figure 5 Sample safety label for ETL



27799

4.2 Safety standards compliance

This section describes the Nokia FastMile 4G Receiver equipment compliance with North American safety standards.



Warning — Changes or modifications to this unit not expressly approved by the party responsible for compliance could void the user's authority to operate the equipment.

4.2.1 EMC, EMI, and ESD compliance

The Nokia FastMile 4G Receiver equipment complies with the following EMC, EMI, and ESD requirements:

- Federal Communications Commission PART 15-RADIO FREQUENCY DEVICES Subpart C-INTENTIONAL RADIATORS Title 47 CFR Part 15. Part 15.247, Part 15.255

This equipment has been tested and found to comply with the limits for a Class B digital device, pursuant to Part 15 of the FCC Rules. These limits are designed to provide reasonable protection against harmful interference in a residential installation. This equipment generates, uses and can radiate radio frequency energy and, if not installed and used in accordance with the instructions, may cause harmful interference to radio communications.

However, there is no guarantee that interference will not occur in a particular installation. If this equipment does cause harmful interference to radio or television reception, which can be determined by turning the equipment off and on, the user is encouraged to try to correct the interference by one or more of the following measures:

- Reorient or relocate the receiving antenna.
- Increase the separation between the equipment and receiver.
- Connect the equipment into an outlet on a circuit different from that to which the receiver is needed.
- Consult the dealer or an experienced radio/TV technician for help.

4.2.2 Equipment safety standard compliance

The Nokia FastMile 4G Receiver equipment complies with the requirements of:

- UL 62368-1 Audio/Video, Information And Communication Technology Equipment - Part 1: Safety Requirements
- CSA C22.2#62368-1 Audio/Video, Information And Communication Technology Equipment - Part 1: Safety Requirements
- UL 60950-22 Information Technology Equipment - Safety - Part 22: Equipment to be Installed Outdoors

4.3 Electrical safety guidelines

This section provides the electrical safety guidelines for the Nokia FastMile 4G Receiver equipment.



Note — The Nokia FastMile 4G Receiver equipment complies with the U.S. National Electrical Code. However, local electrical authorities have jurisdiction when there are differences between the local and U.S. standards.

4.3.1 Power supplies

The use of any non-Nokia approved power supplies or power adapters is not supported or endorsed by Nokia. Such use will void any warranty or support contract with Nokia. Such use greatly increases the danger of damage to equipment or property.

4.3.2 Cabling

The following are the guidelines regarding cables used for the Nokia FastMile 4G Receiver equipment:

- All cables must be approved by the relevant national electrical code.
- Cables for outdoor connection to the Nokia FastMile 4G Receiver equipment must be suitable for outdoor use.
- If cabling is supplied with the Nokia FastMile 4G Receiver, the supplied cabling must be used with the equipment.

4.3.3 Protective earth

Earthing and bonding of the Nokia FastMile 4G Receiver equipment must comply with the requirements of NEC article 250 or local electrical codes.

4.4 ESD safety guidelines

The Nokia FastMile 4G Receiver equipment is sensitive to ESD if opened. Operations personnel must observe the following ESD instructions when they handle the Nokia FastMile 4G Receiver equipment.



Caution — This equipment is ESD sensitive if opened. Proper ESD protections should be used if you open the Nokia FastMile 4G Receiver.

Service personnel are not required to wear wrist straps when performing normal installation or maintenance activities.

4.5 Environmental requirements

See chapter 16 in this document for information about temperature ranges for the Nokia FastMile 4G Receiver equipment and other Nokia FastMile 4G Receiver specifications.

During operation in the supported temperature range, condensation inside the Nokia FastMile 4G Receiver equipment caused by humidity is not an issue because the Nokia FastMile 4G Receiver is a sealed unit.

4.6 Additional information

See chapter 17 for RF exposure information.

See chapter 18 for additional FCC compliance information.

5 Product overview

5.1 Overview of the Nokia FastMile 4G Receiver

5.2 End-to-end example

5.3 Installing the Nokia FastMile 4G Receiver

5.1 Overview of the Nokia FastMile 4G Receiver

The Nokia FastMile 4G Receiver is an outdoor device used in the Nokia FastMile 4G solution.

The Nokia FastMile 4G solution uses 3GPP based LTE radio technology to provide indoor and outdoor broadband connectivity with guaranteed high bitrates in larger service areas in a more cost-efficient manner than is possible with other existing solutions. The Nokia FastMile 4G solution can overcome network performance challenges faced by today's mobile networks by optimizing all of the following:

- intra site interference due to neighbor sectors in same LTE base station
- inter site interference due to neighbor base stations
- link performance due to wall penetration loss and several miles path loss

The Nokia FastMile 4G Receiver provides high-performing, outdoor wireless broadband access over LTE to meet residential users' total home connectivity needs for urban, suburban, rural, and deep rural spots.

The Nokia FastMile 4G Receiver supports LTE connectivity to an LTE base station in the network, and provides 1 Gbps Ethernet connectivity through an Ethernet cable connected to a residential gateway such as the following in the home:

- Nokia 7368 ISAM CPE A-020W-A
- Nokia 7368 ISAM CPE A-240Z-A

The Nokia FastMile 4G Receiver can be installed on the side of a house or on a pole close to the house. A pole mount kit that includes a pole adapter can be ordered from Nokia.

Figure 6 shows an application example where the Nokia FastMile 4G Receiver is mounted on the side of a house.

Figure 6 Application example of the Nokia FastMile 4G Receiver

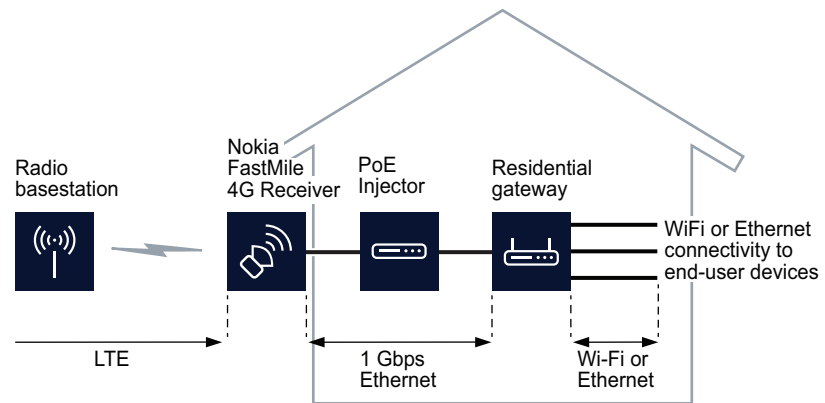

28814

The Nokia FastMile 4G Receiver is available in the following model types:

- Compact multi-band; this model type has the following features:
 - fixed beamforming antennas
 - multi-band transmission
- Compact mono-band; this model type has the following features:
 - fixed beamforming antennas
 - mono-band transmission
- ABA; this model type has the following features:
 - high gain beam steering antenna
 - automated beam alignment

Figure 7 shows examples of the model types of the Nokia FastMile 4G Receiver.

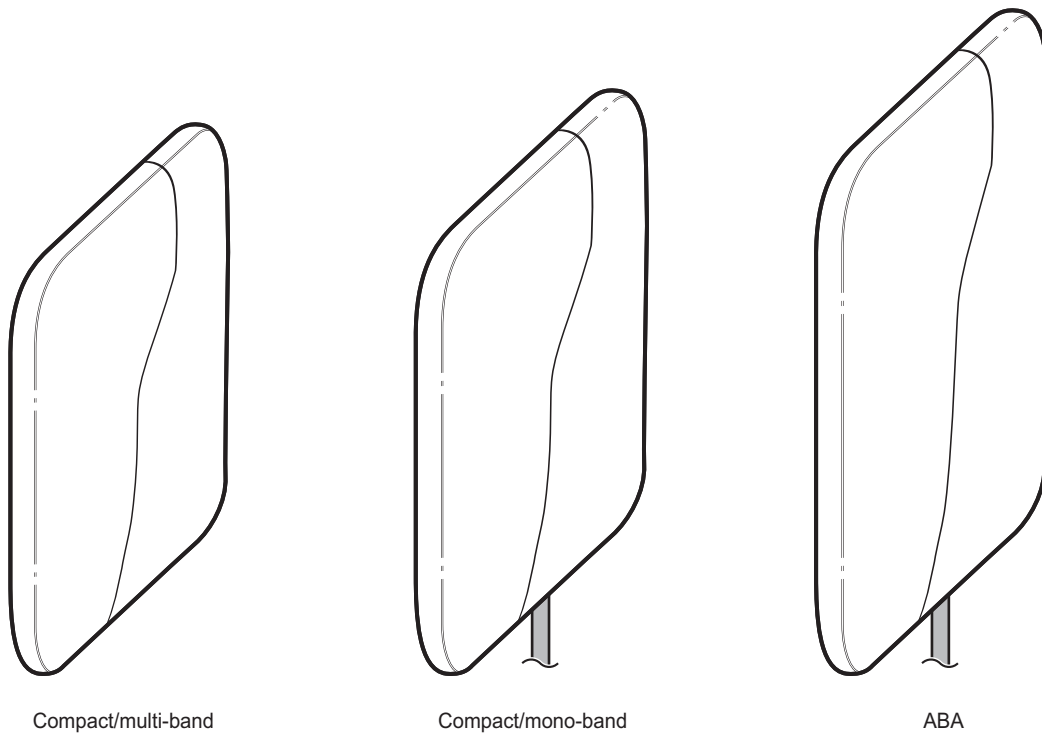
Figure 7 Examples of model types of the Nokia FastMile 4G Receiver

28770

The Nokia FastMile 4G Receiver has built-in antenna and LTE modem that provide the LTE broadband access to the network.

The Nokia FastMile 4G Receiver is capable of withstanding outdoor environmental conditions. It has an IP rating of IP66 TYPE3 and can operate in the following temperature ranges:

- compact mono-band and ABA models can operate in a temperature of -30°C to 65°C (-22°F to 149°F)
- compact multi-band models can operate in a temperature of -30°C to 55°C (-22°F to 131°F); the Model 4G05-B can operate in a temperature of -40°C to 55°C (-40°F to 131°F)

See chapter 16 for additional specifications of the Nokia FastMile 4G Receiver.

5.2 End-to-end example

The Nokia FastMile 4G Receiver can be used to provide IPTV, Internet, and VoIP services to end-users that are connected to the Nokia FastMile 4G Receiver through a Nokia-approved residential gateway or a Nokia-approved PoE injector. The Nokia FastMile 4G Receiver can also connect directly to a video monitor, personal computer, and so on rather than using a residential gateway and PoE injector.

Due to the independence between the Nokia FastMile 4G Receiver and the gateway, the Nokia FastMile 4G Receiver also addresses the business market. The business customer can seamlessly re-use their existing business gateway. The Nokia FastMile 4G Receiver supports extended QCI and multiple APNs that can be mapped on VLANs to support QoS for different services.

Figure 8 shows an end-to-end example that features the Nokia FastMile 4G Receiver with a residential gateway and PoE injector.

Figure 8 End-to-end example featuring the Nokia FastMile 4G Receiver with a residential gateway and PoE injector

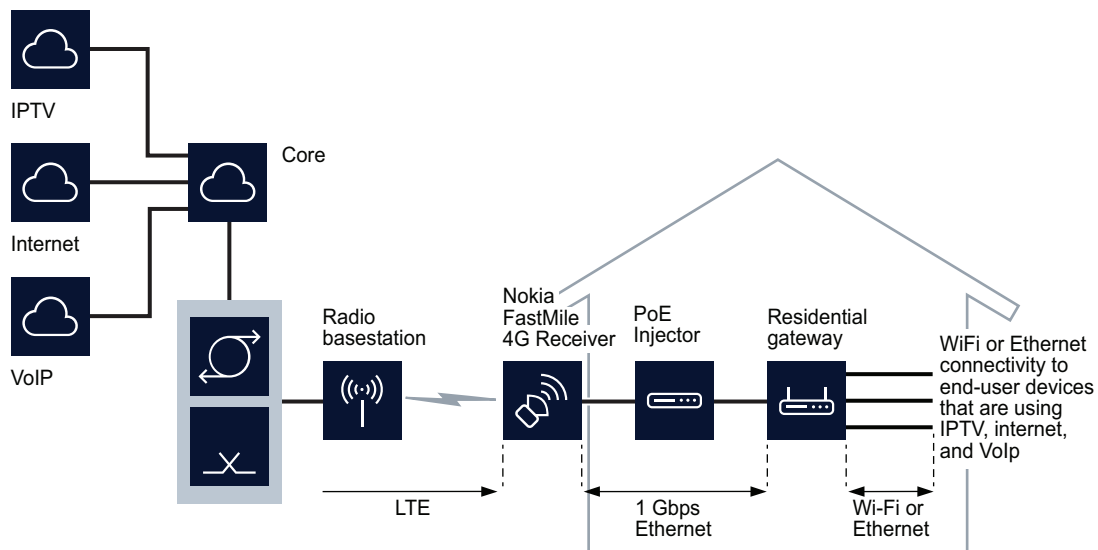

28815

5.3 Installing the Nokia FastMile 4G Receiver

As part of installing the Nokia FastMile 4G Receiver, you can use the Nokia Wireless app (described in section 6.1.1) to help in determining the mounting location for the Nokia FastMile 4G Receiver with either of the following:

- an ACS through TR-069 with help from the Nokia Altiplano FastMile Controller
- an ACS through TR-069 without help from the Nokia Altiplano FastMile Controller

The *Nokia FastMile 4G Receiver Installation Guide* provides steps on how to use the Nokia Wireless app to help in determining the mounting location, and how to install the Nokia FastMile 4G Receiver on the side of a house or on a pole close to the house.

6 Functional overview

6.1 Overview

6.2 LTE characteristics

6.3 Data forwarding

6.4 Ethernet characteristics

6.5 Power supply characteristics

6.6 Remote management protocols

6.1 Overview

The Nokia FastMile 4G Receiver provides wireless broadband access in the form of LTE to meet the ever growing network needs of end users. The Nokia FastMile 4G Receiver is an outdoor device that lets operators use LTE to offer fixed wireless broadband to their customers.

The Nokia FastMile 4G Receiver is easy to install and is user-friendly to operate.

6.1.1 Nokia Wireless app

The Nokia FastMile 4G Receiver can be installed with the assistance of an Android application, known as Nokia Wireless app, installed on a mobile phone. The app in general lets you scan the QR code of the receiver, identify the best location to install the receiver by measuring the signal strength and connect to the receiver over a Bluetooth connection in order to apply configuration.

The Nokia Wireless app also provides management and troubleshooting capabilities for the Nokia FastMile 4G Receiver such as the following:

- viewing information that includes:
 - LTE cell info such as connection state, status, EARFCN, and PCI
 - current and average signal stats for RSRP, RSRQ, RSSI, and SINR
 - other stats (for example, bytes sent and bytes received)
- uploading CA certificates to the Nokia FastMile 4G Receiver
- resetting the 4G Receiver to factory settings
- rebooting the 4G Receiver

See the Installation guide for more information about how the Nokia Wireless app is used in the installation process. See chapter 13 in this document for more information about how Nokia Wireless app can be used for management of the Nokia FastMile 4G Receiver.

6.1.2 Web UI

The Nokia FastMile 4G Receiver supports local management capability, allowing status view and configuration operations, through a Web UI for a Nokia FastMile 4G Receiver managed by an ACS through TR-069.

The Web UI can be accessed directly from a laptop through the Ethernet port of the Nokia FastMile 4G Receiver via the dedicated static IP address 192.168.0.1 (<https://192.168.0.1>). Alternatively, it is possible to access the Web UI from behind a Nokia-approved residential gateway which is appropriately configured.

It is recommended not to change or reconfigure the Nokia FastMile 4G Receiver static IP for the Web UI interface, since changing the default IP address (that is, 192.168.0.1) would impede access from the Web UI.

Web UI functionality is optimized for the following browsers:

- Google Chrome (version 76.0.3809.132 or greater)
- Mozilla Firefox (version 69.0 or greater)
- Microsoft Edge (version 44.18362.267.0 or greater)



Note — Internet Explorer is not supported since it will be replaced by Edge and will not be updated from Microsoft any more.

The Web UI design is optimized for a resolution of 1920x1080 pixels, but is not restricted to it.



Note — The Web UI is based on https. The client browser will indicate an unknown certificate warning because a Nokia signed certificate is used; this does not constitute a security issue or threat. It is safe to accept the certificate.

See chapter 14 in this document for information about using the Web UI to manage the Nokia FastMile 4G Receiver.

6.1.3 Remote management

The Nokia FastMile 4G Receiver supports remote management capability, allowing management and health monitoring of it from the Nokia Altiplano FastMile Controller (through NETCONF) or from an ACS (through TR-069).



Note 1 — The NETCONF version of the FastMile 4G Receiver for remote management from the Nokia Altiplano FastMile Controller is not supported from FM 2.0.03a onwards.

Note 2 — The Nokia FastMile 4G Receiver supports DHCP option 43 when it works as a DHCP server for the gateway by providing information about the ACS to the gateway. The relevant DHCP option 43 parameters must be configured in the preconfig.xml file.

See the documentation for the Nokia Altiplano FastMile Controller for information about managing and monitoring the Nokia FastMile 4G Receiver through the Nokia Altiplano FastMile Controller.

See section 6.6 for information about the remote management protocols.

6.2 LTE characteristics

The following are some of the key LTE characteristics of the Nokia FastMile 4G Receiver:

- LTE 3GPP Release 12 Compliant, UE Category 12
- transmit power: max +23 dBm +/- 2 dBm
- supports the E-UTRA bands listed in Table 3

Table 3 E-UTRA bands supported by the Nokia FastMile 4G Receiver

E-UTRA bands	Model
Band 42/43/48 (mono-band support)	4G01-A
Band 42/43/48 ⁽¹⁾ (ABA support)	4G01-B
Band 3 (mono-band support)	4G02-A
Band 7/38/40/41 (mono-band support)	4G03-A
Band 3/7/20/32 (multi-band support)	4G04-A
Band 1/3/7/38/40/41/20/28 (multi-band support)	4G05-A and 4G05-B

(1 of 2)

E-UTRA bands	Model
Band 2/25/4/66/7/42/43/48 ⁽²⁾ /28 (multi-band support)	4G06-A << does (2) need to be removed and Note 2 removed or re-worded as per ALU02675463 (Fastmile 4G - 4G06-A with pre-installed CBSD certificate) >>
Band 1/3/7/20/32 (multi-band support)	4G17-A

(2 of 2)

Notes

- (1) Note that B48 for the 4G01-B has not been tested for FCC certification and is not ready for commercial use in this release.
- (2) Note that FCC certification for B48 for the 4G06-A is ongoing and is not ready for commercial use in this release << **remove or re-word?** >>

6.3 Data forwarding

The Nokia FastMile 4G Receiver supports the following data forwarding methods:

Table 4 Data forwarding methods supported by the Nokia FastMile 4G Receiver

Forwarding mode	Typical use
Single APN with multi-bearers for route mode	Recommended for using only one APN specific for Nokia FastMile 4G Receiver
Single APN with multi-bearers for bridge mode	Could be used for WAN of the Nokia FastMile 4G Receiver with VLAN tag
Multiple APNs with bridge mode	Used as multi-APN, separated service with APNs: each APN is for each service. Note in this case, a specific port should be reserved for service traffic.
Multiple APNs with mixed mode	Can be used for separated APNs on OAM and also other APNs for separated services: <ul style="list-style-type: none"> • Only default APN is in route mode which could be OAM • Besides APN, each APN is for each service
Tunnel mode	Can be used for using tunnel for L2 forwarding such as PPPoE

6.4 Ethernet characteristics

The following are some of the key Ethernet characteristics of the Nokia FastMile 4G Receiver:

- provides a 1 Gbps Ethernet LAN Interface that, depending on the model of the Nokia FastMile 4G Receiver, has the following:
 - the Compact mono-band and ABA models have a pre-attached 3 m (9.8 ft) Cat5e shielded UV resistant twisted pair Ethernet cable with a male RJ 45 connector at the free end; the 4G01-A and 4G03-A Compact mono-band models are also available with a pre-attached 20 m (65.6 ft) Cat5e shielded UV resistant twisted pair Ethernet cable with a male RJ 45 connector at the free end << **confirm 4G01-A** >>
 - the Compact multi-band models have a female RJ 45 connector that supports connection of a customer-supplied Ethernet cable:
 - the Model 4G17-A requires a Cat5e shielded or non-shielded twisted pair Ethernet cable with standard pinouts that is up to a maximum of 80 m (262 ft) in length << **confirm all this info** >>
 - all other Compact multi-band models require a Cat5e shielded twisted pair Ethernet cable with standard pinouts that is up to a maximum of 80 m (262 ft) in length
- supports IEEE802.3 1000BASE-T
- supports IEEE802.3az energy efficient Ethernet
- the Ethernet cable for all models is also used for power over Ethernet (PoE) as per IEEE802.3 at type-2

6.5 Power supply characteristics

The following are some of the key power supply characteristics of the Nokia FastMile 4G Receiver:

- powered through PoE from a Nokia-approved residential gateway, or through a Nokia-approved PoE injector (see section 11.2 for information about PoE injectors for use with the FastMile 4G Receiver)
- supports PoE+ as per IEEE802.3 at type-2
- rating: 53 VDC at 600 mA

See section 11.1 for power information.

6.6 Remote management protocols

Remote management of the Nokia FastMile 4G Receiver can be done from the Nokia Altiplano FastMile Controller through NETCONF or from an ACS through TR-069/TR181 depending on the installed SIM card.



Note — The NETCONF version of the FastMile 4G Receiver for remote management from the Nokia Altiplano FastMile Controller is not supported from FM 2.0.03a onwards.

For the first startup, the Nokia FastMile 4G Receiver starts from the NETCONF version. The Nokia FastMile 4G Receiver will automatically detect the remote management protocol through information that is on the SIM card installed in the unit. If the Nokia FastMile 4G Receiver detects that the remote management protocol on the SIM card is TR-069/TR181, it restarts and starts up with TR-069/TR181 management.

If the remote management protocol is NETCONF, the Nokia FastMile 4G Receiver can be managed remotely from the Nokia Altiplano FastMile Controller.

If the remote management protocol is TR-069, the Nokia FastMile 4G Receiver can be managed remotely from an ACS.

Figure 9 shows the Nokia Altiplano FastMile Controller being used for remote management of the Nokia FastMile 4G Receiver. Note that NETCONF is used by the Nokia Altiplano FastMile Controller to manage the Nokia FastMile 4G Receiver, and that an ACS manages the residential gateway through TR-069.

Figure 9 Remote management of the Nokia FastMile 4G Receiver through the Nokia Altiplano FastMile Controller

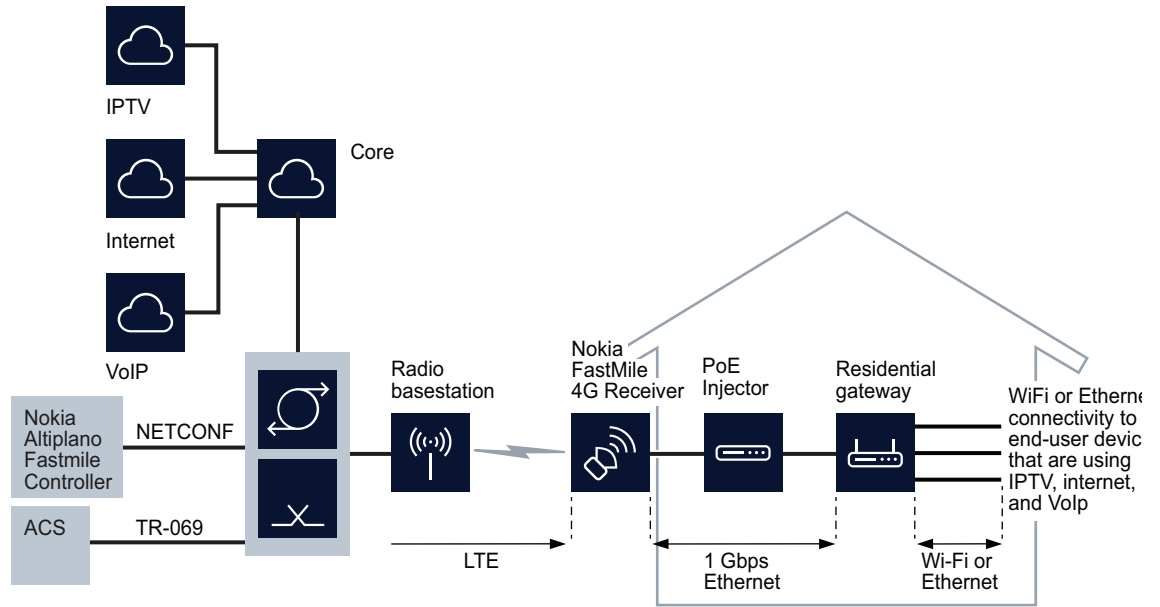

28

Figure 10 shows an ACS being used for remote management of the Nokia FastMile 4G Receiver. Note that the ACS uses TR-069 to manage both the Nokia FastMile 4G Receiver and the residential gateway.

Figure 10 Remote management of the Nokia FastMile 4G Receiver through an ACS

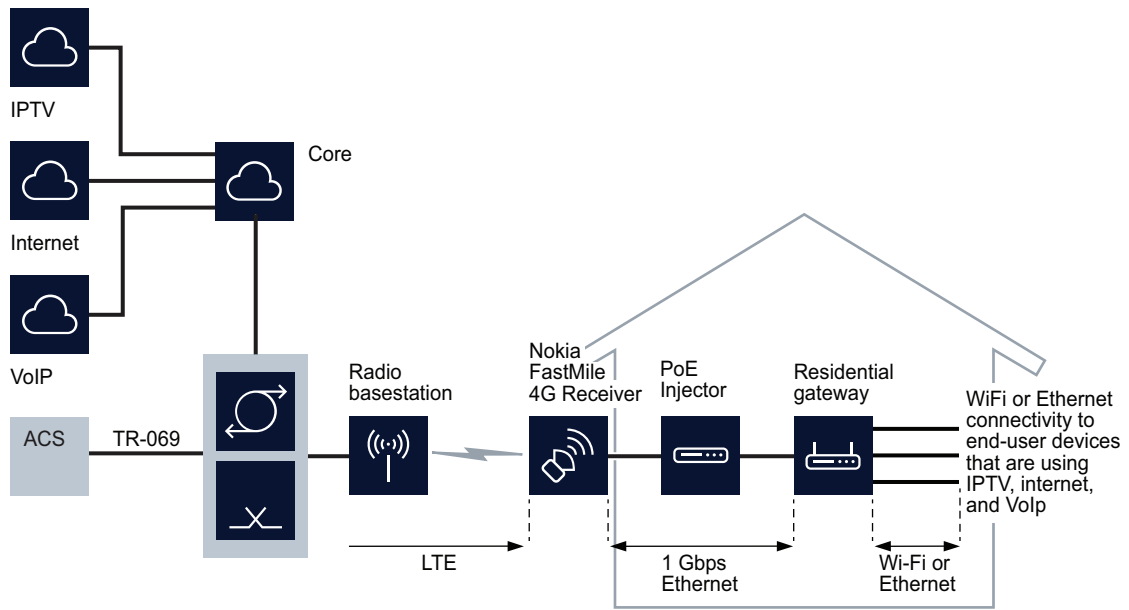

28817

7 Model overview

7.1 Models of the Nokia FastMile 4G Receiver

7.1 Models of the Nokia FastMile 4G Receiver

A wide range of models are available for the Nokia FastMile 4G Receiver to support different E-UTRA bands and band combinations for LTE, including the capability to limit the bands to be used among the bands physically supported, to support network resource planning, and to speed up the cell attach speed.

All models can be wall-mounted or pole-mounted. If you will be mounting the Nokia FastMile 4G Receiver on a pole, you will need kit 3TG-00291-AA that contains the pole adapter for the Nokia FastMile 4G Receiver. Note that pole strapping and wall fasteners are not provided by Nokia.

Table 5 describes the E-UTRA band and frequency support and the antenna configurations for each model of the Nokia FastMile 4G Receiver.

Table 5 Models of the Nokia FastMile 4G Receiver

Model	E-UTRA band support and frequencies	Antenna configuration	Model type
4G01-A	<ul style="list-style-type: none"> Band 42: TDD, 3400 MHz – 3600 MHz Band 43: TDD, 3600 MHz – 3800 MHz Band 48: TDD, 3550 MHz – 3700 MHz 	Integrated with 15 dBi fixed beamforming antenna	Compact mono-band << add any other info in this table or elsewhere for RCR ALU02675458 (Fastmile 4G - 4G01-A with 20m pigtail and pre-installed CBSD certificate)? >>
4G01-B	<ul style="list-style-type: none"> Band 42: TDD, 3400 MHz – 3600 MHz Band 43: TDD, 3600 MHz – 3800 MHz Band 48⁽¹⁾: TDD, 3550 MHz – 3700 MHz 	Integrated with 3x4 dual polarized antenna array, electronic beam steering +/- 45° horizontally, and up to 17 dBi peak antenna gain with beam steering	ABA
4G02-A	<ul style="list-style-type: none"> Band 3: FDD, Tx 1710 MHz – 1785 MHz, Rx 1805 MHz – 1880 MHz 	Integrated with 10.5 dBi fixed beamforming antenna	Compact mono-band
4G03-A	<ul style="list-style-type: none"> Band 7: FDD, Tx 2500 MHz – 2570 MHz, Rx 2620 MHz – 2690 MHz Band 38: TDD, 2570 MHz – 2620 MHz Band 40: TDD, 2300 MHz – 2400 MHz Band 41: TDD, 2496 MHz – 2690 MHz 	Integrated with 12.5 dBi fixed beamforming antenna	Compact mono-band

(1 of 3)

Model	E-UTRA band support and frequencies	Antenna configuration	Model type
4G04-A	<ul style="list-style-type: none"> Band 3: FDD, Tx 1710 MHz –1785 MHz, Rx 1805 MHz – 1880 MHz Band 7: FDD, Tx 2500 MHz – 2570 MHz, Rx 2620 MHz – 2690 MHz Band 20: FDD, Tx 832 MHz – 862 MHz Rx 791 MHz – 821 MHz Band 32: FDD, Rx 1452 MHz – 1496 MHz 	<p>Band 7 is integrated with > 11 dBi fixed beamforming antenna</p> <p>Band 3 is integrated with > 10 dBi fixed beamforming antenna</p> <p>Band 32 is integrated with > 8.3 dBi fixed beamforming antenna</p> <p>Band 20 is integrated with > 2.5dBi fixed beamforming antenna</p>	Compact multi-band
4G05-A	<ul style="list-style-type: none"> Band 1: FDD, Tx 1920 MHz –1980 MHz, Rx 2110 MHz –2170 MHz Band 3: FDD, Tx 1710 MHz –1785 MHz, Rx 1805 MHz – 1880 MHz Band 7: FDD, Tx 2500 MHz – 2570 MHz, Rx 2620 MHz – 2690 MHz Band 38: TDD, 2570 MHz – 2620 MHz Band 40: TDD, 2300 MHz – 2400 MHz Band 41: TDD, 2496 MHz – 2690 MHz Band 20: FDD, Tx 832 MHz – 862 MHz, Rx 791 MHz – 821 MHz Band 28: FDD, Tx 703 MHz – 748 MHz, Rx 758 MHz – 803 MHz 	<p>Bands 7, 38, 40, and 41 are integrated with > 11 dBi fixed beamforming antenna</p> <p>Bands 1 and 3 are integrated with > 10 dBi fixed beamforming antenna</p> <p>Bands 20 and 28 are integrated with > 2.5 dBi fixed beamforming antenna</p>	Compact multi-band
4G05-B	<ul style="list-style-type: none"> Band 1: FDD, Tx 1920 MHz –1980 MHz, Rx 2110 MHz –2170 MHz Band 3: FDD, Tx 1710 MHz –1785 MHz, Rx 1805 MHz – 1880 MHz Band 7: FDD, Tx 2500 MHz – 2570 MHz, Rx 2620 MHz – 2690 MHz Band 38: TDD, 2570 MHz – 2620 MHz Band 40: TDD, 2300 MHz – 2400 MHz Band 41: TDD, 2496 MHz – 2690 MHz Band 20: FDD, Tx 832 MHz – 862 MHz, Rx 791 MHz – 821 MHz Band 28: FDD, Tx 703 MHz – 748 MHz, Rx 758 MHz – 803 MHz 	<p>Bands 7, 38, 40, and 41 are integrated with > 11 dBi fixed beamforming antenna</p> <p>Bands 1 and 3 are integrated with > 10 dBi fixed beamforming antenna</p> <p>Bands 20 and 28 are integrated with > 2.5 dBi fixed beamforming antenna</p>	Compact multi-band similar to Model 4G05-A but for use in colder temperatures
4G06-A	<ul style="list-style-type: none"> Band 2: FDD, Tx 1850 MHz - 1910 MHz, Rx 1930 MHz - 1990 MHz Band 25: FDD, Tx 1850 MHz - 1915 MHz, Rx 1930 MHz - 1995 MHz Band 4: FDD, Tx 1710 MHz - 1755 MHz, Rx 2110 MHz - 2155 MHz Band 66: FDD, Tx 1710 MHz - 1780 MHz, Rx 2110 MHz - 2200 MHz Band 7: FDD, Tx 2500 MHz - 2570 MHz, Rx 2620 MHz - 2690 MHz Band 42: TDD, 3400 MHz - 3600 MHz Band 43: TDD, 3600 MHz - 3800 MHz Band 48⁽²⁾: TDD, 3550 MHz - 3700 MHz; Band 28: FDD, Tx 703 MHz - 748 MHz, Rx 758 MHz -- 803 MHz 	<p>Bands 2, 25, 4, and 66 are integrated with > 9.3 dBi fixed beamforming antenna</p> <p>Bands 7 is integrated with > 11 dBi fixed beamforming antenna</p> <p>Bands 42, 43 and 48⁽²⁾ are integrated with > 11 dBi fixed beamforming antenna</p> <p>Band 28 is integrated with > 2.5 dBi fixed beamforming antenna</p>	Compact multi-band << does (2) need to be removed and Note 2 removed or re-worded as per ALU02675463 (Fastmile 4G - 4G06-A with pre-installed CBSD certificate) >>

(2 of 3)

Model	E-UTRA band support and frequencies	Antenna configuration	Model type
4G17-A	<ul style="list-style-type: none"> Band 1: FDD, Tx 1920 MHz -1980 MHz, Rx 2110 MHz -2170 MHz Band 3: FDD, Tx 1710 MHz -1785 MHz, Rx 1805 MHz - 1880 MHz Band 7: FDD, Tx 2500 MHz - 2570 MHz, Rx 2620 MHz - 2690 MHz Band 20: FDD, Tx 832 MHz - 862 MHz, Rx 791 MHz - 821 MHz Band 32: FDD, Rx 1452 MHz - 1496 MHz 	<p>Band 7 is integrated with > 11 dBi fixed beamforming antenna</p> <p>Bands 1 and 3 are integrated with > 10 dBi fixed beamforming antenna</p> <p>Band 32 is integrated with > 8.3 dBi fixed beamforming antenna</p> <p>Band 20 is integrated with > 2.5dBi fixed beamforming antenna</p>	Compact multi-band

(3 of 3)

Notes

- (1) Note that B48 for the 4G01-B has not been tested for FCC certification and is not ready for commercial use in this release.
- (2) Note that FCC certification for B48 for the 4G06-A is ongoing and is not ready for commercial use in this release. << remove or re-word? >>

7.1.1 Label information

Table 6 describes the label information for the Nokia FastMile 4G Receiver.

Table 6 Label information for the Nokia FastMile 4G Receiver

Model	Product details
4G01-A	Nokia FM compact
4G01-B	Nokia FM ABA
4G02-A	Nokia FM compact
4G03-A	Nokia FM compact
4G04-A	Nokia FM compact
4G05-A	Nokia FM compact
4G05-B	Nokia FM compact
4G06-A	Nokia FM compact
4G17-A	Nokia FM compact

8 Physical interfaces

8.1 Physical interfaces of the Compact mono-band and ABA models

8.2 Physical interfaces of the Compact multi-band models

8.1 Physical interfaces of the Compact mono-band and ABA models

Table 7 describes the physical interfaces of the Compact mono-band and ABA models of the Nokia FastMile 4G Receiver.

Table 7 Physical interfaces of the Compact mono-band and ABA models of the Nokia FastMile 4G Receiver

Interface	Description
Ground point	Point for connecting to external ground. Connection to the ground point is not required. Located on the underside of the unit; see Figure 11.
Ethernet cable	Ethernet connectivity for the Compact mono-band and ABA models is through a pre-attached 3 m (9.8 ft) cat5e shielded UV resistant Ethernet cable; the same cable is also used for power (PoE as per IEEE802.3 at type-2). PoE must be provided by a Nokia-approved residential gateway or a Nokia-approved PoE injector (see section 11.2 for information about PoE injectors for use with the FastMile 4G Receiver). The 4G01-A and 4G03-A Compact mono-band models are also available with a pre-attached 20 m (65.6 ft) Cat5e shielded UV resistant twisted pair Ethernet cable.<< confirm 4G01-A >> Located on the underside of the unit; see Figure 11. The pre-attached Ethernet cable has a male RJ 45 connector at the free end. An additional length of cat5e shielded UV resistant Ethernet cabling can be attached to the Ethernet cable up to a maximum of 80 m (262 ft) in combined length. A waterproof IP67 female RJ 45 plug is needed to connect the Ethernet cabling to the Ethernet cable of the Nokia FastMile 4G Receiver.
Status LED	Single multifunction LED that indicates status information for the Nokia FastMile 4G Receiver. Located on the underside of the unit; see Figure 11. See section 10.1 for the behavior of the status LED of the Compact mono-band and ABA models.
Reset button	Button to reset the Nokia FastMile 4G Receiver. Located on the underside of the unit; see Figure 11.

(1 of 2)

Interface	Description
SIM slot	Slot for Nano/4FF SIM card for a Compact mono-band model or ABA model of the Nokia FastMile 4G Receiver. Located on the underside of the unit; see Figure 11. If the SIM card needs to be replaced, the Nokia FastMile 4G Receiver needs to be put in a powered off state before the SIM card can be removed and the new one inserted See section 9.1 for SIM card information for the Compact mono-band and ABA models of the Nokia FastMile 4G Receiver.

(2 of 2)

Figure 11 shows the location of the physical interfaces on the Compact mono-band and ABA models of the Nokia FastMile 4G Receiver.

Figure 11 Location of physical interfaces on the Compact mono-band and ABA models of the Nokia FastMile 4G Receiver

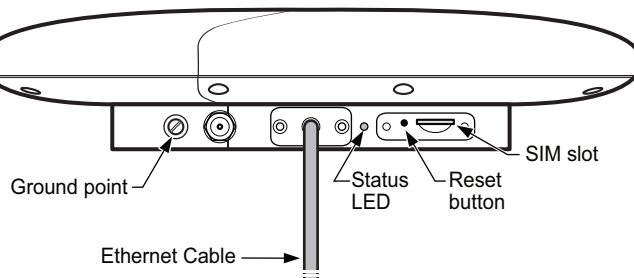

28797

8.2 Physical interfaces of the Compact multi-band models

Table 8 describes the physical interfaces of Compact multi-band models of the Nokia FastMile 4G Receiver.

Table 8 Physical interfaces of the Compact multi-band models of the Nokia FastMile 4G Receiver

Interface	Description
Ground point	Point for connecting to external ground. Connection to the ground point is not required. Located on the back of the unit; see Figure 12.

(1 of 2)

Interface	Description
Ethernet port	<p>The Compact multi-band models have a female RJ 45 connector for attaching a customer-supplied Ethernet cable:</p> <ul style="list-style-type: none"> the Model 4G17-A has a floating ground design that supports a Cat5e shielded or non-shielded twisted pair Ethernet cable with standard pinouts that is up to a maximum of 80 m (262 ft) in length << confirm all this info >> all other Compact multi-band models require a cat5e shielded Ethernet cable with standard pinouts that is a maximum of 80 m (262 ft) in length <p>The same Ethernet cable is also used for power (PoE as per IEEE802.3 at type-2). PoE must be provided by a Nokia-approved residential gateway or a Nokia-approved PoE injector (see section 11.2 for information about PoE injectors for use with the FastMile 4G Receiver).</p> <p>The Ethernet port is located on the underside of the unit; see Figure 13.</p>
Status LED	<p>Single multifunction LED that indicates status information for the Nokia FastMile 4G Receiver.</p> <p>Located on the top of the unit.</p> <p>See section 10.1 for a figure showing the location of the status LED of the Compact multi-band models and information about its behavior.</p>
Signal strength LEDs	<p>The Compact multi-band models have a set of five LEDs that work together to indicate the LTE signal strength detected by the Nokia FastMile 4G Receiver.</p> <p>Located on the top of the unit.</p> <p>See section 10.2 for a figure showing the location of the signal strength LEDs and information about their behavior.</p>
Measurement button	<p>Button to activate the signal strength LEDs.</p> <p>Located on the side of the unit.</p> <p>See section 10.2 for a figure showing the location of the measurement button and information about using it to activate the signal strength LEDs.</p>
Reset button	<p>Button to reset the Nokia FastMile 4G Receiver.</p> <p>Located on the underside of the unit; see Figure 13.</p>
SIM slot	<p>Slot for Nano/4FF SIM card for a Compact multi-band model of the Nokia FastMile 4G Receiver.</p> <p>Located on the underside of the unit; see Figure 13.</p> <p>See section 9.2 for SIM card information for the Compact multi-band models of the Nokia FastMile 4G Receiver.</p>

(2 of 2)

Figure 12 shows the location of the ground point for the Compact multi-band models of the Nokia FastMile 4G Receiver.

Figure 12 Location of the ground point for the Compact multi-band models of the Nokia FastMile 4G Receiver

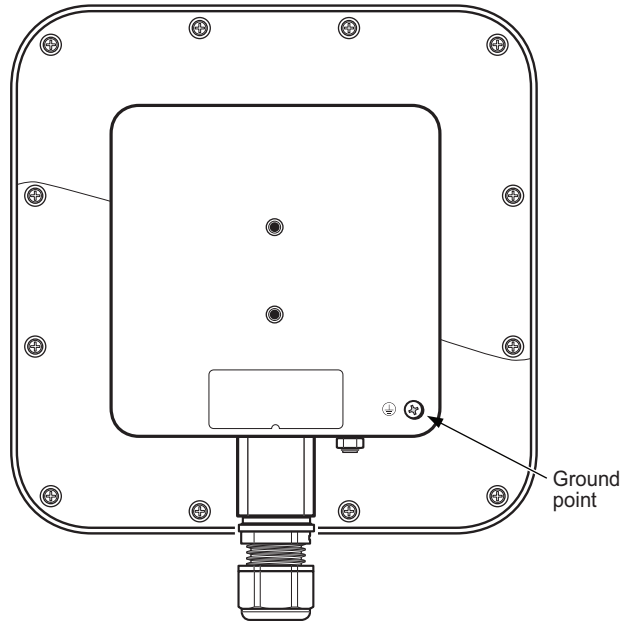

28798

Figure 13 shows the location of the physical interfaces that are on the underside of the Compact multi-band models of the Nokia FastMile 4G Receiver.

Figure 13 Location of physical interfaces on the underside of the Compact multi-band models of the Nokia FastMile 4G Receiver

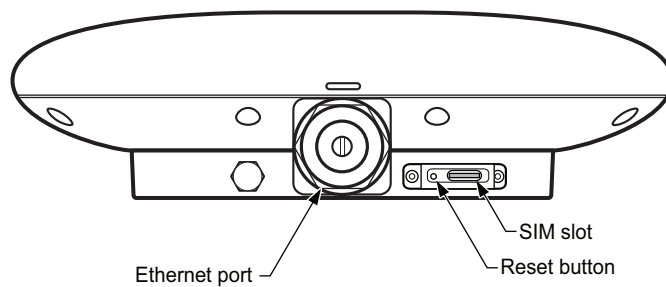

28771

9 SIM cards

9.1 SIM card information for the Compact mono-band and ABA models

9.2 SIM card information for the Compact multi-band models

9.1 SIM card information for the Compact mono-band and ABA models

The SIM card installed in the Nokia FastMile 4G Receiver allows the Nokia FastMile 4G Receiver to connect to the LTE network and determines the remote management protocol supported for the Nokia FastMile 4G Receiver; see section 6.6 for more information about remote management.

Figure 14 shows a detailed view of the SIM card slot on the Compact mono-band and ABA models of the Nokia FastMile 4G Receiver.

Figure 14 Detailed view of SIM card slot on the Compact mono-band and ABA models

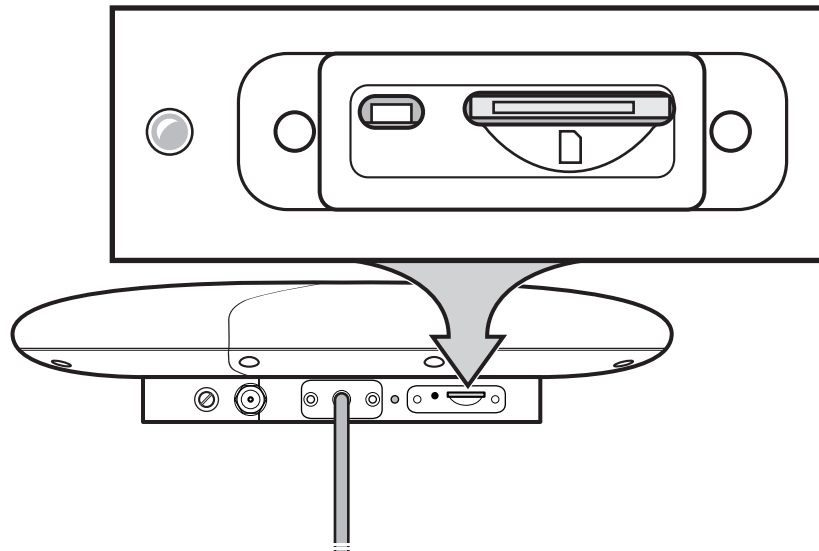

28642

The Nokia FastMile 4G Receiver Installation Guide provides detailed steps for inserting the SIM card. The SIM card must be appropriate for the remote management protocol to be used for the Nokia FastMile 4G Receiver.

9.2 SIM card information for the Compact multi-band models

The SIM card installed in the Nokia FastMile 4G Receiver allows the Nokia FastMile 4G Receiver to connect to the LTE network and determines the remote management protocol supported for the Nokia FastMile 4G Receiver; see section 6.6 for more information about remote management.

Figure 15 shows a detailed view of the SIM card slot on the Compact multi-band models of the Nokia FastMile 4G Receiver.

Figure 15 Detailed view of SIM card slot on the Compact multi-band models

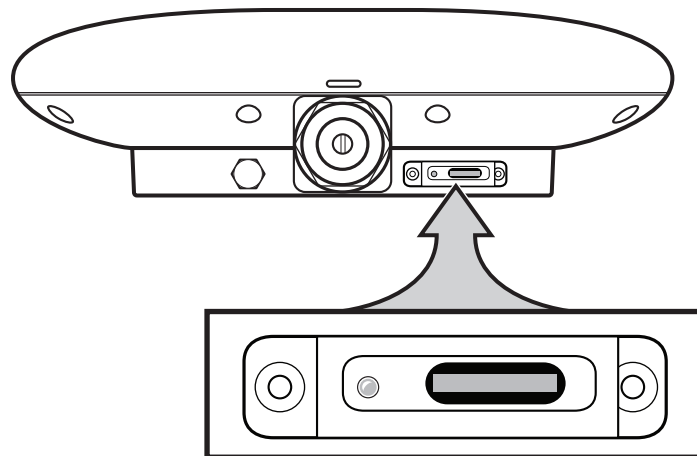

28802

The Nokia FastMile 4G Receiver Installation Guide provides detailed steps for inserting the SIM card. The SIM card must be appropriate for the remote management protocol to be used for the Nokia FastMile 4G Receiver.

10 LEDs

10.1 Status LED

10.2 Signal strength LEDs

10.1 Status LED

All models of the Nokia FastMile 4G Receiver have a status LED:

- Figure 16 shows the location of the status LED on the Compact mono-band and ABA models of the Nokia FastMile 4G Receiver
- Figure 17 shows the location of the status LED on the Compact multi-band models of the Nokia FastMile 4G Receiver

Figure 16 Location of the status LED on the Compact mono-band and ABA models of the Nokia FastMile 4G Receiver

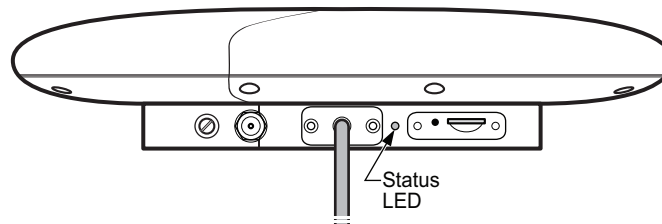

28799

Figure 17 Location of the status LED on the Compact multi-band models of the Nokia FastMile 4G Receiver

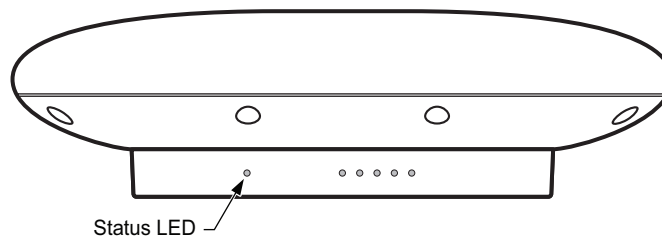

28772

The status LED behaves differently depending on whether the Nokia FastMile 4G Receiver is managed from:

- the Nokia Altiplano FastMile Controller (through NETCONF): see Table 9
- an ACS (through TR-069): see Table 10



Note — The NETCONF version of the FastMile 4G Receiver for remote management from the Nokia Altiplano FastMile Controller is not supported from FM 2.0.03a onwards

Table 9 Status LED behavior for Nokia FastMile 4G Receiver managed from the Nokia Altiplano FastMile Controller

LED color	LED priority	LED behavior	Status information
Blue	First priority	Blinking	Bluetooth connection in progress
		Solid	Bluetooth connection established
		Off	No Bluetooth connection
Red	Second priority	Blinking	Critical alarm
		Solid	Major or minor alarm
		Off	No alarm
Green	Third priority	Blinking twice per second	Kernel and application start up
		Blinking one per second	Application start up
		Solid	Start up
		Off	OAM link is established

Table 10 Status LED behavior for Nokia FastMile 4G Receiver managed from an ACS

LED color	LED priority	LED behavior	Status information
Blue	First priority	Blinking	Bluetooth connection in progress
		Solid	Bluetooth connection established
		Off	No Bluetooth connection
Green	Second priority	Blinking twice per second	Kernel and application start up
		Blinking one per second	Application start up
		Solid	Start up
		Off	Software is stable

10.2 Signal strength LEDs

Five signal strength LEDs are provided on the Compact multi-band models of the Nokia FastMile 4G Receiver as shown in Figure 18.

Figure 18 Location of the signal strength LEDs

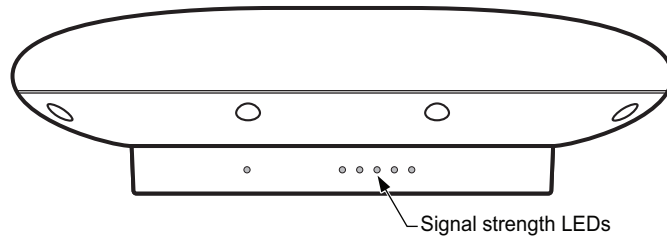

28773

The signal strength LEDs can be activated by pressing the measurement button on the side of the Compact multi-band models of the Nokia FastMile 4G Receiver. Figure 19 shows the location of the measurement button.

Figure 19 Location of the measurement button

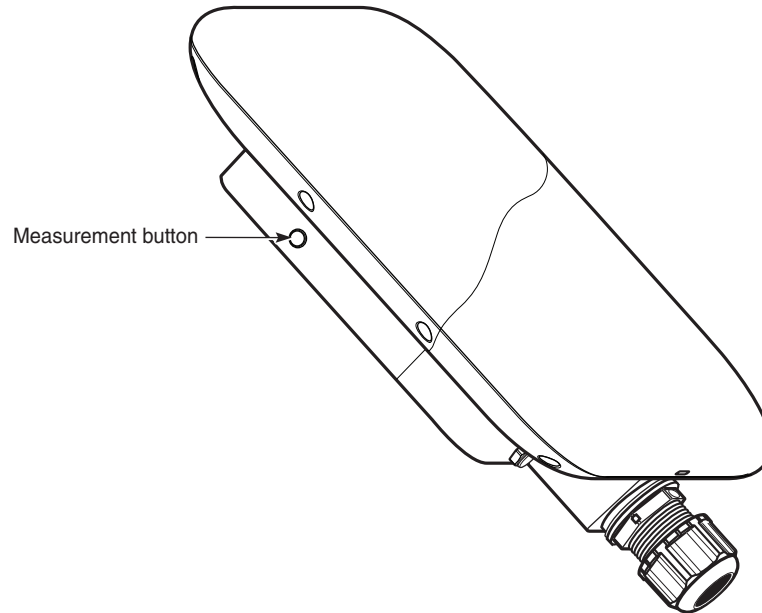

28885

The signal strength LEDs act as a set to indicate the LTE signal strength detected by the Nokia FastMile 4G Receiver. For example, if the signal strength is fourth level, then LEDs 1, 2, 3, and 4 are lit. Table 11 lists the threshold values for the signal strength LEDs, but note that the threshold values can be changed through an ACS.

Table 11 Signal strength LED threshold values

Number of lit LEDs	Threshold
None	<-110dBm
One	-110 to -106 dBm
Two	-105 to -101dBm
Three	-100 to -96dBm
Four	-95 to -91dBm
Five	>=-90dBm

11 Power information

11.1 Power information for the Nokia FastMile 4G Receiver

11.2 Available PoE injectors

11.1 Power information for the Nokia FastMile 4G Receiver

The Nokia FastMile 4G Receiver receives power through a Cat5e shielded Ethernet cable that must be connected to a Nokia-approved residential gateway or a Nokia-approved PoE injector (see section 11.2 for information about PoE injectors available from Nokia for use with the FastMile 4G Receiver).

- Compact mono-band and ABA models have a pre-attached Cat5e shielded twisted pair Ethernet cable with a male RJ 45 connector at the free end. An additional length of cat5e shielded Ethernet cabling can be attached to the Ethernet cable up to a maximum of 80 m (262 ft) in combined length. A waterproof IP67 female RJ 45 plug is needed to connect the Ethernet cabling to the Ethernet cable of the Nokia FastMile 4G Receiver. See section 8.1 for more information about the pre-attached Ethernet cable.
- Compact multi-band models have an Ethernet port that has a female RJ 45 connector, and require a customer-supplied Ethernet cable (See section 8.2 for more information about the Ethernet port):
 - the Model 4G17-A has a floating ground design that supports a cat5e shielded or non-shielded twisted pair Ethernet cable with standard pinouts that is up to a maximum of 80 m (262 ft) in length << **confirm all this info** >>
 - all other Compact multi-band models require a cat5e shielded Ethernet cable with standard pinouts that is a maximum of 80 m (262 ft) in length

See section 12.4 for power consumption information.

11.2 Available PoE injectors

If the Nokia FastMile 4G Receiver is going to be powered through a PoE injector, the PoE injector must be a Nokia-approved PoE injector.

The following classes of PoE injectors are available from Nokia for use with the FastMile 4G Receiver:

- Class I: can comply with EN 60950-1 if grounding is provided on the wall socket; should be put as close as possible to the place where the Ethernet cable enters the home
- Class II: can comply with EN 60950-1 if no grounding is provided on the wall socket; can also be used if grounding is provided on the wall socket

The following tables list the PoE injectors that are available from Nokia for use with the FastMile 4G Receiver:

- Table 12 lists the PoE injectors that are available from Nokia for use with the Model 4G05-B
- Table 13 lists the PoE injectors that are available from Nokia for use with the Model 4G17-A
- Table 14 lists the PoE injectors that are available from Nokia for use with all other models of the FastMile 4G Receiver

Table 12 Available PoE injectors for Model 4G05-B

Class	Model	Description	Color	Nokia part number	Vendor part number
Class I	15w Class I PoE injector	PoE+15w ClassI, MAINS CORD TYPE E&F-EU	White	3TG-01541-AB	G1344A-530-030-PSE1000, CH-231+CH-706,White,EU

Table 13 Available PoE injectors for Model 4G17-A

Class	Model	Description	Color	Nokia part number	Vendor part number
Class II	15w Class II PoE injector	PoE+15w ClassII, MAINS CORD TYPE C-EU	White	3TG-01541-BB	G1344B-530-030-PSE1000, CH-221+CH-705,White,EU

Table 14 Available PoE injectors for models other than Model 4G05-B and Model 4G17-A

Class	Model	Description	Color	Nokia part number	Vendor part number
Class I	30w FWAPoE1-CB-US-W	30w G0545 53V0.6A, MAINS CORD TYPE B-US	White	3TG-00041-AA	G0545-530-060-PSE1000, CH-331C+CH-706,White,US
	30wFWAPoE1-CEF-EU-W	30w G0545 53V0.6A, MAINS CORD TYPE E&F-EU	White	3TG-00041-AB	G0545-530-060-PSE1000, CH-231+CH-706,White,EU
	30w FWAPoE1-CG-UK-W	30w G0545 53V0.6A, MAINS CORD TYPE G-UK	White	3TG-00041-AC	G0545-530-060-PSE1000, CH-1601+CH-706,White,UK
	30w FWAPoE1-CI-CCC-W	30w G0545 53V0.6A, MAINS CORD TYPE I-CCC	White	3TG-00041-AD	G0545-530-060-PSE1000, CH-133+CH-706,White,CCC
	30w FWAPoE1-CI-AU-W	30w G0545 53V0.6A, MAINS CORD TYPE I-AU	White	3TG-00041-AE	G0545-530-060-PSE1000, CH-1231+CH-706,White,AU
	30wFWAPoE1-CB-PSE-W	30w G0545 53V0.6A, MAINS CORD TYPE B-PSE	White	3TG-00041-AF	G0545-530-060-PSE1000, CH-1131+CH-1106,White,PSE
	30w FWAPoE1-CD-BIS-W	30w G0545 53V0.6A, MAINS CORD TYPE D-BIS	White	3TG-00041-AG	G0545-530-060-PSE1000, CH-2002+CH-706,White,BIS
Class II	30w FWAPoE1-CC-EU-W	30w G0545 53V0.6A, MAINS CORD TYPE C-EU	White	3TG-00041-BB	G0545N-530-060-PSE1000, CH-221+CH-706,White,EU

12 Performance information

12.1 Performance overview

12.2 Throughput information

12.3 Carrier aggregation information

12.4 Power consumption information

12.1 Performance overview

This chapter provides the following performance information for the Nokia FastMile 4G Receiver:

- throughput information: see section [12.2](#)
- carrier aggregation information: see section [12.3](#)
- power consumption information: section [12.4](#)

Some performance metrics for the Nokia FastMile 4G Receiver can be viewed through the Nokia Wireless app or Web UI or accessed through the Nokia Altiplano FastMile Controller:

- see chapter [13](#) for more information about viewing information for the Nokia FastMile 4G Receiver through the Nokia Wireless app
- see chapter [14](#) for more information about viewing information for the Nokia FastMile 4G Receiver through the Web UI
- see the documentation for the Nokia Altiplano FastMile Controller for more information about accessing information for the Nokia FastMile 4G Receiver through the Nokia Altiplano FastMile Controller

12.2 Throughput information

Table [15](#) provides LTE throughput information for the Nokia FastMile 4G Receiver.

Table 15 LTE throughput information

Mode	UDP DL (3CA)	TCP DL (3CA)	UDP UL	TCP UL
FDD	560M	360M	73M	73M
TDD	415M	360M	14M	18M

The results in the above table are based on the following:

- Downlink: DL 3xCA 2x2MIMO 256 QAM
- Uplink: single carrier 64 QAM
- FDD inter-band 3CA
- TDD Band 41 intra-Band 2CA, configuration is configuration 2, subframe 7
- Base Bandwidth 20M
- Data rates can have a margin of 2%
- Packet length is 1470B for UDP
- Window is 1000k for TCP
- Data rates are for IPv4 cases
- Data forwarding working on router model

The end-to-end throughput is achieved in the conductive mode with cable connected.

Ethernet throughput for the Nokia FastMile 4G Receiver is as per standard Ethernet 1000BASE-T, with a maximum of 1000 Mbps. The Ethernet link gets negotiated at 1000 Mbps when a residential gateway or a PoE injector is connected to the Nokia FastMile 4G Receiver.

12.3 Carrier aggregation information

<< the 4G02-A and 4G03-A tables will be replaced with the updated tables from Issue 03 of the FM 2.1.04 Nokia FastMile 4G Receiver Product Overview after that doc has been approved >>

The following tables provide carrier aggregation support information for the Nokia FastMile 4G Receiver:

- Model 4G01-A and 4G01-B (2*2 MIMO downlink with SISO uplink): Table 16
- Model 4G02-A (2*2 MIMO downlink with SISO uplink): Table 17
- Model 4G03-A (2*2 MIMO downlink with SISO uplink): Table 18
- Model 4G04-A (2*2 MIMO downlink with SISO uplink): Table 19
- Model 4G05-A and 4G05-B (2*2 MIMO downlink): Table 20
- Model 4G06-A (2*2 MIMO downlink): Table 21
- Model 4G17-A (2*2 MIMO downlink with SISO uplink): Table 22



Note 1 — B48 for the 4G01-B has not been tested for FCC certification and is not ready for commercial use in this release.

Note 2 — FCC certification for B48 for the 4G06-A is ongoing and is not ready for commercial use in this release. <<does Note 2 need to be removed or re-worded as per ALU02675463 (Fastmile 4G - 4G06-A with pre-installed CBSD certificate)? >>

Table 16 Carrier aggregation support for Model 4G01-A and Model 4G01-B (2*2 MIMO downlink with SISO uplink)

Index	Downlink				Upload	
	PCC	SCC1	SCC2	SCC3	PCC	SCC
1	42A	43A				
2	43A	42A				
3	42C					
4	43C					
5	48C					
6	42A	42A				
7	43A	43A				
8	48A	48A				
9	42A	43A			42A	43A
10	43A	42A			43A	42A
11	42C				42C	
12	43C				43C	
13	48C				48C	
14	42A	42A			42A	42A
15	43A	43A			43A	43A
16	48A	48A			48A	48A
17	42A	43C				
18	43A	42C				
19	42A	42A	43A			
20	42A	43A	43A			
21	43A	43A	42A			
22	43A	42A	42A			
23	42D					
24	43D					
25	48D					
26	42A	42A	42A			
27	43A	43A	43A			
28	48A	48A	48A			
29	42A	43C			42A	43A
30	43A	42C			43A	42A
31	42A	42A	43A		42A	42A

(1 of 3)

Index	Downlink				Upload	
	PCC	SCC1	SCC2	SCC3	PCC	SCC
32	42A	43A	43A			
33	43A	43A	42A			
34	43A	42A	42A			
35	42D					
36	43D					
37	48D					
38	42A	42A	42A			
39	43A	43A	43A			
40	48A	48A	48A			
41	42A					
42	43A					
43	42A	42A	42A	43A		
44	42A	43A	43A	43A		
45	42A	43A	43A	43A		
46	43A	42A	42A	42A		
47	43A	43A	42A	42A		
48	43A	43A	43A	42A		
49	42E					
50	43E					
51	48E					
52	42A	42A	42A	42A		
53	43A	43A	43A	43A		
54	48A	48A	48A	48A		
55	42A	43D			42A	43A
56	43A	42D			43A	42A
57	42A	42A	42A	43A	42A	42A
58	42A	42A	43A	43A	42A	42A
59	42A	43A	43A	43A	42A	43A
60	43A	42A	42A	42A	43A	42A
61	43A	43A	42A	42A	43A	43A
62	43A	43A	43A	42A	43A	43A
63	42E				42C	
64	43E				43C	

(2 of 3)

Index	Downlink				Upload	
	PCC	SCC1	SCC2	SCC3	PCC	SCC
65	48E				48C	
66	42A	42A	42A	42A	42A	42A
67	43A	43A	43A	43A	43A	43A
68	48A	48A	48A	48A	48A	48A

(3 of 3)

Table 17 Carrier aggregation support for Model 4G02-A (2*2 MIMO downlink with SISO uplink)

Index	Downlink		Uplink	
	PCC	SCC1	PCC	SCC1
1	3C			
2	3A	3A		
3	3C		3C	
4	3A	3A	3A	3A
5	3D			
6	3D		3C	
7	3E			
8	3E		3C	

Table 18 Carrier aggregation support for Model 4G03-A (2*2 MIMO downlink with SISO uplink)

index	Downlink		Uplink	
	PCC	SCC	PCC	SCC
1	7C			
2	38C			
3	40C			
4	41C			
5	7A	7A		
6	38A	38A		
7	40A	40A		
8	41A	41A		
9	7C		7C	

(1 of 2)

index	Downlink		Uplink	
	PCC	SCC	PCC	SCC
10	38C		38C	
11	40C		40C	
12	41C		41C	
13	7A	7A	7A	7A
14	38A	38A	38A	38A
15	40A	40A	40A	40A
16	41A	41A	41A	41A
17	7D			
18	38D			
19	40D			
20	41D			
21	7C	7A		
22	38C	38A		
23	40C	40A		
24	41C	41A		
25	7D		7C	
26	38D		38C	
27	40D		40C	
28	41D		41C	
29	7C	7A	7A	7A
30	38C	38A	38A	38A
31	40C	40A	40A	40A
32	41C	41A	41A	41A
33	40E			
34	41E			
35	40C	40C		
36	41C	41C		
37	40E		40C	
38	41E		41C	
39	40C	40C	40A	40A
40	41C	41C	41A	41A

(2 of 2)

Table 19 Carrier aggregation support for Model 4G04-A (2*2 MIMO downlink with SISO uplink)

Index	Downlink			Uplink	
	PCC	SCC1	SCC2	PCC	SCC1
1	3A	7A			
2	3A	20A			
3	3A	32A			
4	7A	3A			
5	20A	3A			
6	7A	20A			
7	7A	32A			
8	20A	7A			
9	20A	32A			
10	3A	7A		3A	7A
11	3A	20A		3A	20A
12	7A	3A		7A	3A
13	20A	3A		20A	3A
14	7A	20A		7A	20A
15	20A	7A		20A	7A
16	3A	7A	20A		
17	7A	3A	20A		
18	20A	7A	3A		
19	3A	20A	32A		
20	20A	3A	32A		

Table 20 Carrier aggregation support for Model 4G05-A and Model 4G05-B (2*2 MIMO downlink)

Index	Downlink		
	PCC	SCC1	SCC2
1	1A	3A	
2	3A	1A	
3	1A	7A	
4	7A	1A	
5	1A	38A	

(1 of 5)

Index	Downlink		
	PCC	SCC1	SCC2
6	38A	1A	
7	1A	41A	
8	41A	1A	
9	3A	7A	
10	7A	3A	
11	3A	20A	
12	20A	3A	
13	3A	28A	
14	28A	3A	
15	3A	38A	
16	38A	3A	
17	3A	40A	
18	40A	3A	
19	3A	41A	
20	41A	3A	
21	28A	40A	
22	40A	28A	
23	28A	41A	
24	41A	28A	
25	3C		
26	28C		
27	40C		
28	41C		
29	1A	3C	
30	3C	1A	
31	1C	7A	
32	7A	1C	
33	3A	7C	
34	7C	3A	
35	3A	38C	
36	38C	3A	
37	3A	40C	
38	40C	3A	

(2 of 5)

Index	Downlink		
	PCC	SCC1	SCC2
39	3A	41C	
40	41C	3A	
41	28A	40C	
42	40C	28A	
43	28A	41C	
44	41C	28A	
45	1A	3A	7A
46	3A	1A	7A
47	7A	3A	1A
48	1A	3A	38A
49	3A	1A	38A
50	38A	3A	1A
51	1A	3A	41A
52	3A	1A	41A
53	41A	3A	1A
54	3A	28A	40A
55	28A	3A	40A
56	40A	28A	3A
57	3A	28A	41A
58	28A	3A	41A
59	41A	28A	3A
60	41D		
61	1C	3C	
62	3C	1C	
63	1A	3D	
64	3D	1A	
65	3C	7C	
66	7C	3C	
67	3A	7D	
68	7D	3A	
69	3C	38C	
70	38C	3C	
71	3A	38D	

(3 of 5)

Index	Downlink		
	PCC	SCC1	SCC2
72	38D	3A	
73	3C	40C	
74	40C	3C	
75	3A	40D	
76	40D	3A	
77	3C	41C	
78	41C	3C	
79	3A	41D	
80	41D	3A	
81	28C	40C	
82	40C	28C	
83	28A	40D	
84	40D	28A	
85	28C	41C	
86	41C	28C	
87	28A	41D	
88	41D	28A	
89	1A	3A	7C
90	3A	1A	7C
91	7C	3A	1A
92	1A	3C	7A
93	3C	1A	7A
94	7A	3C	1A
95	1A	3A	38C
96	3A	1A	38C
97	38C	3A	1A
98	1A	3C	38A
99	3C	1A	38A
100	38A	3C	1A
101	1A	3A	41C
102	3A	1A	41C
103	41C	3A	1A
104	1A	3C	41A

(4 of 5)

Index	Downlink		
	PCC	SCC1	SCC2
105	3C	1A	41A
106	41A	3C	1A
107	3A	28A	40C
108	28A	3A	40C
109	40C	28A	3A
110	3A	28C	40A
111	28C	3A	40A
112	40A	28C	3A
113	3A	28A	41C
114	28A	3A	41C
115	41C	28A	3A
116	3A	28C	41A
117	28C	3A	41A
118	41A	28C	3A

(5 of 5)

Table 21 Carrier aggregation support for Model 4G06-A (2*2 MIMO down-link)

Index	Downlink			
	PCC	SCC1	SCC2	SCC3
1	2A	4A		
2	4A	2A		
3	2A	7A		
4	7A	2A		
5	2A	28A		
6	28A	2A		
7	2A	42A		
8	42A	2A		
9	2A	48A		
10	48A	2A		
11	2A	66A		
12	66A	2A		
13	4A	7A		

(1 of 5)

Index	Downlink			
	PCC	SCC1	SCC2	SCC3
14	7A	4A		
15	4A	28A		
16	28A	4A		
17	4A	42A		
18	42A	4A		
19	4A	43A		
20	43A	4A		
21	7A	28A		
22	28A	7A		
23	7A	42A		
24	42A	7A		
25	7A	43A		
26	43A	7A		
27	7A	66A		
28	66A	7A		
28	28A	42A		
30	42A	28A		
31	28A	43A		
32	43A	28A		
33	28A	66A		
34	66A	28A		
35	42A	66A		
36	66A	42A		
37	43A	66A		
38	66A	43A		
39	2C			
40	4C			
41	7C			
42	25C			
43	28C			
44	42C			
45	43C			
46	48C			

(2 of 5)

Index	Downlink			
	PCC	SCC1	SCC2	SCC3
47	66C			
48	2A	4A	28A	
49	4A	2A	28A	
50	28A	2A	4A	
51	2A	4A	48A	
52	4A	2A	48A	
53	48A	2A	4A	
54	2A	7A	42A	
55	7A	2A	42A	
56	42A	2A	7A	
57	2A	28A	42A	
58	28A	2A	42A	
59	42A	2A	28A	
60	2A	28A	43A	
61	28A	2A	43A	
62	43A	2A	28A	
63	2A	28A	66A	
64	28A	2A	66A	
65	66A	2A	28A	
66	2A	48A	66A	
67	48A	2A	66A	
68	66A	2A	48A	
69	4A	7A	28A	
70	7A	4A	28A	
71	28A	4A	7A	
72	4A	7A	42A	
73	7A	4A	42A	
74	42A	4A	7A	
75	4A	7A	43A	
76	7A	4A	43A	
77	43A	4A	7A	
78	4A	28A	42A	
79	28A	4A	42A	

(3 of 5)

Index	Downlink			
	PCC	SCC1	SCC2	SCC3
80	42A	4A	28A	
81	4A	28A	43A	
82	28A	4A	43A	
83	43A	4A	28A	
84	7A	28A	66A	
85	28A	7A	66A	
86	66A	7A	28A	
87	7A	42A	66A	
88	42A	7A	66A	
89	66A	7A	42A	
90	7A	43A	66A	
91	43A	7A	66A	
92	66A	7A	43A	
93	28A	42A	66A	
94	42A	28A	66A	
95	66A	28A	42A	
96	28A	43A	66A	
97	43A	28A	66A	
98	66A	28A	43A	
99	4A	7A	28A	42A
100	7A	4A	28A	42A
101	28A	7A	4A	42A
102	42A	7A	28A	4A
103	4A	7A	28A	43A
104	7A	4A	28A	43A
105	28A	7A	4A	43A
106	43A	7A	28A	4A
107	7A	28A	42A	66A
108	28A	7A	42A	66A
109	42A	28A	7A	66A
110	66A	28A	42A	7A
111	7A	28A	43A	66A
112	28A	7A	43A	66A

(4 of 5)

Index	Downlink			
	PCC	SCC1	SCC2	SCC3
113	43A	28A	7A	66A
114	66A	28A	43A	7A

(5 of 5)

Table 22 Carrier aggregation support for Model 4G17-A (2*2 MIMO downlink with SISO uplink)

Index	Downlink				Uplink		
	PCC	SCC1	SCC2	SCC3	PCC	SCC1	SCC2
1	1A	3A					
2	3A	1A					
3	1A	7A					
4	7A	1A					
5	3A	7A					
6	7A	3A					
7	1A	32A					
8	3A	32A					
9	7A	32A					
10	1A	3A			1A	3A	
11	3A	1A			3A	1A	
12	1A	7A			1A	7A	
13	7A	1A			7A	1A	
14	3A	7A			3A	7A	
15	1A	3A	7A				
16	3A	1A	7A				
17	7A	3A	1A				
18	1A	3A	32A				
19	3A	1A	32A				
20	3A	7A	32A				
21	7A	3A	32A				
22	1A	7A	32A				
23	7A	1A	32A				
24	1A	3A	7A		1A	3A	
25	3A	1A	7A		3A	1A	

(1 of 2)

Index	Downlink				Uplink		
	PCC	SCC1	SCC2	SCC3	PCC	SCC1	SCC2
26	1A	3A	7A		1A		7A
27	7A	3A	1A		7A		1A
28	3A	1A	7A		3A		7A
29	7A	3A	1A		7A	3A	
30	1A	3A	32A		1A	3A	
31	3A	1A	32A		3A	1A	
32	3A	7A	32A		3A	7A	
33	7A	3A	32A			3A	
34	1A	7A	32A		1A	7A	
35	7A	1A	32A			1A	
36	1A	3A	7A	32A			
37	3A	1A	7A	32A			
38	7A	3A	1A	32A			
39	1A	3A	7A	32A	1A	3A	
40	3A	1A	7A	32A	3A	1A	
41	1A	3A	7A	32A	1A		7A
42	7A	3A	1A	32A	7A		1A
43	3A	1A	7A	32A	3A		7A
44	7A	1A	3A	32A	7A		3A

(2 of 2)

12.4 Power consumption information

Table 23 provides power consumption information for all models of the Nokia FastMile 4G Receiver.

Table 23 Power consumption information for all models

Condition	Power consumption
Maximum power output	12W
Idle power	1.6 W

13 Management using the Nokia Wireless app

13.1 Using the Nokia Wireless app to manage the Nokia FastMile 4G Receiver

13.2 Using the Nokia Wireless app to manage a unit managed by the Nokia Altiplano FastMile Controller

13.3 Using the Nokia Wireless app to manage a unit managed by an ACS

13.1 Using the Nokia Wireless app to manage the Nokia FastMile 4G Receiver

After the Nokia FastMile 4G Receiver has been installed as described in the installation guide, you can use the Nokia Wireless app to perform management activities on it, such as viewing information, uploading CA certificates, rebooting the Nokia FastMile 4G Receiver, or resetting to factory settings.

The user of the Nokia Wireless app has to agree with the “Terms of Service” and the “Nokia Privacy Policy” that define the app. This is a mandatory step during the first start up of the app. Terms of Service can be found inside the Nokia Wireless app whereas a link is provided to the Nokia Privacy Policy, which is described in the Nokia public webpage. The user can find this information later on by visiting the “About” screen of the app.

Figure 20 shows the “Before we begin” screen that provides access to the Terms of Service and the Nokia Privacy Policy.

Figure 20 Before we begin screen

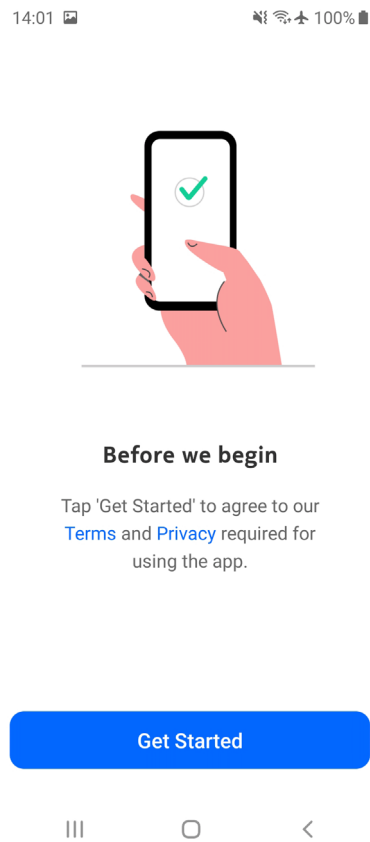
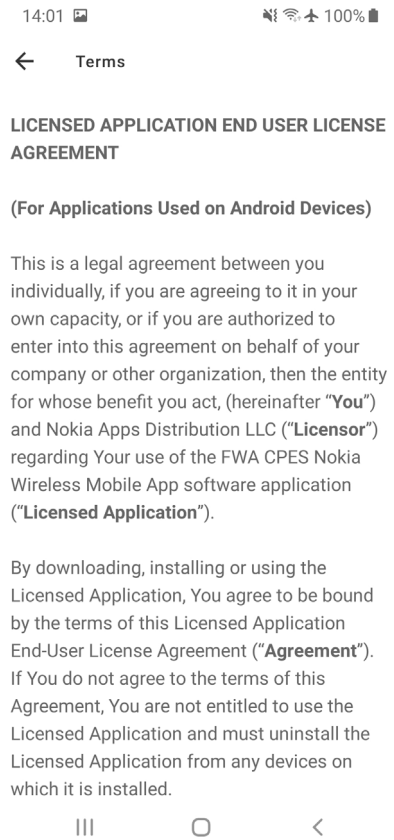

Figure 21 shows the “Terms of Service” screen that is accessed through the “Before we begin” screen.

Figure 21 Terms of Service screen



The Nokia Wireless app is protected as much as possible against malicious users. Tools like obfuscation and encryption used by the Nokia Wireless app, as well as runtime checks and tamper detection, make it hard for malicious users to understand the code flow or to hack the application.

There are some differences in managing the Nokia FastMile 4G Receiver through the Nokia Wireless app depending on whether the Nokia FastMile 4G Receiver is managed remotely by the Nokia Altiplano FastMile Controller (through NETCONF) or by an ACS (through TR-069):

- if the Nokia Altiplano FastMile Controller is being used for remote management of the Nokia FastMile 4G Receiver (through NETCONF), see section [13.2](#)
- if an ACS is being used for remote management of the Nokia FastMile 4G Receiver (through TR-069), see section [13.3](#)

13.2 Using the Nokia Wireless app to manage a unit managed by the Nokia Altiplano FastMile Controller

If the Nokia Altiplano FastMile Controller is being used for remote management of the Nokia FastMile 4G Receiver (through NETCONF), you can use the Nokia Wireless app to perform management activities on it, such as viewing information, uploading CA certificates, rebooting the Nokia FastMile 4G Receiver, or resetting to factory settings, as described in the following procedure.



Note — The NETCONF version of the FastMile 4G Receiver for remote management from the Nokia Altiplano FastMile Controller is not supported from FM 2.0.03a onwards.

You will need the QR code that was saved as described during installation the Nokia FastMile 4G Receiver in order to scan it when logging in to it through the Nokia Wireless app. Logging in to the Nokia FastMile 4G Receiver also includes the following:

- initiating a Bluetooth connection
- enabling Bluetooth
- allowing the Bluetooth pairing request
- establishing the VPN connection
- entering the username and password



Note — The Bluetooth connection from the Nokia Wireless app towards the Nokia FastMile 4G Receiver is closed after one hour of inactivity in order to preserve Nokia Wireless phone resources. There is a mechanism in place that enables the user to re-establish the Bluetooth connection when he or she re-enters the app.

Procedure 5 To perform management activities

Use the following procedure to perform management activities through the Nokia Wireless app for a Nokia FastMile 4G Receiver that is managed remotely by the Nokia Altiplano FastMile Controller through NETCONF.

-
- 1 When you are close to the Nokia FastMile 4G Receiver, connect the mobile phone to the Internet and open the Nokia Wireless app on the phone.

An introductory screen with a video appears.

Figure 22 shows the introductory screen.

Figure 22 **Introductory screen for unit managed by the Nokia Altiplano FastMile Controller through NETCONF**

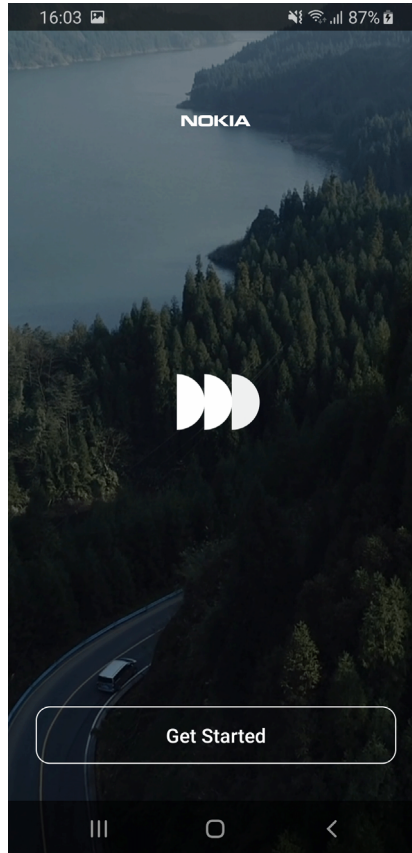

Continue by tapping on “Get started”.

- 2 After the introductory screen has cleared, the Nokia Wireless app shows an animation of how to scan the QR code of the Nokia FastMile 4G Receiver so that the app can obtain the MAC address, unique device identifier, enterprise id, and device type of the Nokia FastMile 4G Receiver.

The QR code was provided on a sheet of paper in the shipping package of the Nokia FastMile 4G Receiver. The sheet of paper, or a photograph of it, should have been saved and made available for anyone who later needs to scan the QR code when accessing the Nokia FastMile 4G Receiver.

Figure 23 shows the screen for the prompt to scan the QR code.

Figure 23 Screen with prompt to scan the QR code for unit managed by the Nokia Altiplano FastMile Controller through NETCONF

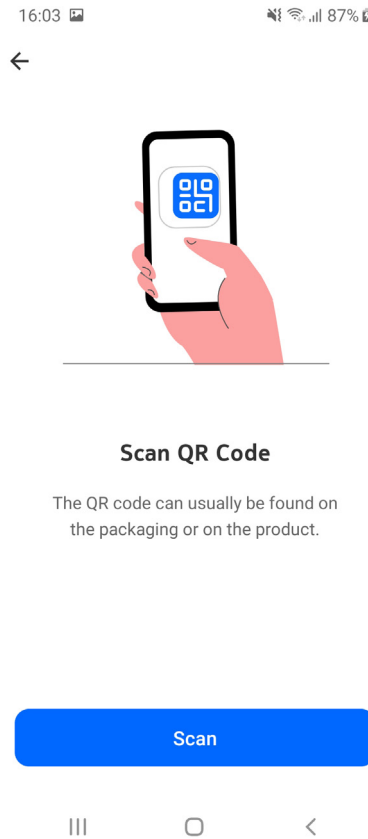

Tap on “Scan” to start the scan of the QR code.

Use the viewfinder of the phone to align with the QR code.

Figure 24 shows the QR code screen.

Figure 24 QR code screen for unit managed by the Nokia Altiplano FastMile Controller through NETCONF



- 3 The Nokia Wireless app displays the screen to install the Nokia FastMile 4G Receiver. Tap on the "Already Installed?" option. Figure 25 shows the Already Installed option.

Figure 25 Screen showing the Already Installed option for unit managed by the Nokia Altiplano FastMile Controller through NETCONF



- 4 The Nokia Wireless app prompts you to connect to the Nokia FastMile 4G Receiver. The connection will be done through Bluetooth in conjunction with a VPN. You will need to be close to the Nokia FastMile 4G Receiver and you will need to have Bluetooth enabled on the mobile phone and accept the pairing request when it appears.

Figure 26 shows the screen to connect to the Nokia FastMile 4G Receiver.

Figure 26 Screen for connecting to the Nokia FastMile 4G Receiver

Connect to the Nokia FastMile 4G Receiver by tapping on “Connect”.

- 5 The Nokia Wireless app prompts you to enable the VPN profile for a secure method to communicate with the Nokia FastMile 4G Receiver.

Figure 27 shows the screen to enable the VPN profile.

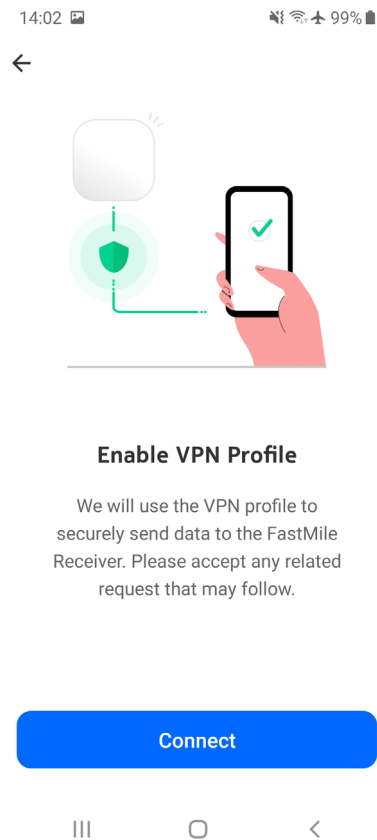
Figure 27 Screen for enabling the VPN profile

Enable the VPN profile by tapping on “Connect”.

- 6 The android system of the mobile phone prompts you to accept the connection request. Figure 28 shows the prompt to accept the connection request.

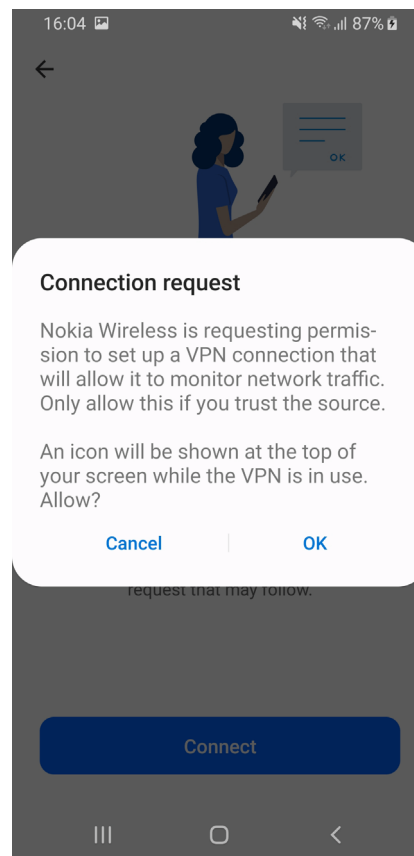
Figure 28 Prompt for accepting the connection request

Accept the connection request by tapping on “OK”.

- 7 The Nokia Wireless app prompts you to log in to the Nokia FastMile 4G Receiver. You will need to input the username and password for the Nokia FastMile 4G Receiver.

Figure 29 shows the screen to log in to the Nokia FastMile 4G Receiver.

Figure 29 Screen to log in to a Nokia FastMile 4G Receiver managed by the Nokia Altiplano FastMile Controller

16:04 87%

←

Login to FastMile Receiver

Username
fm2-operator ✓

Password
•••••••• ✓

Log in

☰ ○ <

Log in to the Nokia FastMile 4G Receiver by tapping on “Log in”.

After you have logged in, you can:

- view information for the Nokia FastMile 4G Receiver: see step [8](#)
- upload updated certificates to the Nokia FastMile 4G Receiver: see step [9](#)
- reboot the Nokia FastMile 4G Receiver: see step [10](#)
- change the configuration settings to the default factory load settings (Perform Factory Reset); see step [11](#)

-
- 8** You can view the following information for a Nokia FastMile 4G Receiver managed by the Nokia Altiplano FastMile Controller by selecting the Connection Status option of the main screen and scrolling through the screen by swiping up or down:
- LTE cell info:
 - connection state: Does the Nokia FastMile 4G Receiver connect to this cell
 - status: The current operational state of the PDN connection
 - EARFCN: The carrier frequency in the uplink and downlink is designated by the E-UTRA. Absolute Radio Frequency Channel Number (EARFCN) in the range 0 - 65535.
 - PCI: The physical cellid of cell
 - Current signal stats:
 - RSRP: RSRP (Reference Signals Received Power) is a measurement of the received power level in an LTE cell network in dBm
 - RSRQ: RSRQ (Reference Signals Received Quality) is a measurement of the received power quality in an LTE cell network in dB
 - RSSI: RSSI (Received Signal Strength Indicator) is a measurement of the power present in a received radio signal by the Nokia FastMile 4G Receiver
 - SINR: SINR (the Signal-to-Interference-plus-Noise ratio) is used in the LTE network from the Nokia FastMile 4G Receiver side to measure the quality of wireless connections in dB
 - Average signal stats:
 - RSRP: average value of Reference Signal Received Power (dBm) in the measured interval, resolution 1dBm
 - RSRQ: average value of Reference Signal Received Quality (dB) in the measured interval, resolution 1dB
 - RSSI: average value of Received Signal Strength indicator (dBm) in the measured interval, resolution 1
 - SINR: average value of Signal-to-Interference-plus-Noise Ratio (dB) in the measured interval, resolution 1dB
 - Other stats:
 - bytes sent: the total number of bytes sent on the interface
 - bytes received: the total number of bytes received on the interface

Figure 30 shows an example of the System state screen.

Figure 30 System state screen example for a Nokia FastMile 4G Receiver managed by the Nokia Altiplano FastMile Controller

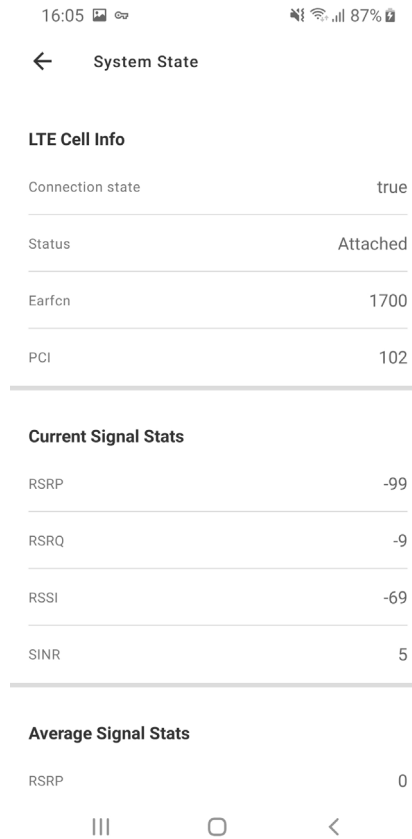

Note — The Nokia Wireless app will display a value of “N/A” for parameters that are not supported by the installed Home 4G Receiver Software version.

The following additional Beam Angle information is displayed only for an ABA version as shown in Figure 31:

- Antenna mode: wide or narrow
- Horizontal angle: the horizontal angle is expressed as a degree if the Antenna mode is narrow or as N/A if the antenna mode is wide

Figure 31 System state screen with Beam Angle information for a Nokia FastMile 4G Receiver managed by the Nokia Altiplano FastMile Controller

System State	
SINR	40
Average Signal Stats	
RSRP	10
RSRQ	11
RSSI	12
SINR	13
Other Stats	
Bytes Sent	101
Bytes Received	100
Beam Angle Information	
Antenna mode	narrow
Horizontal angle	20

9 You can upload updated certificates (stored under downloads in the mobile phone's directory) to the Nokia FastMile 4G Receiver.

- i** Tap on the “Upload CA certificates” option.

Figure 32 shows the screen that has the “Upload CA certificates” option.

Figure 32 Screen that has the “Upload CA certificates” option for a Nokia FastMile 4G Receiver managed by the Nokia Altiplano FastMile Controller

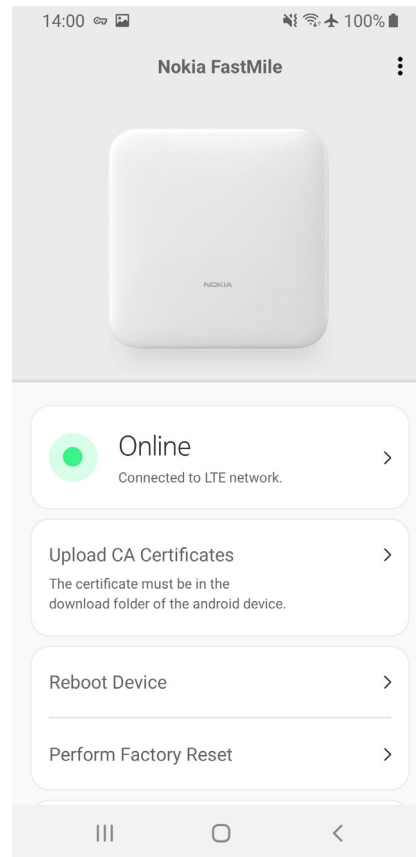

- ii Select the required CA certificates and tap on “Ok”. Note that the certificates must be in the download folder of the mobile phone before you can upload them to the Nokia FastMile 4G Receiver.

Figure 33 shows the screen that lists the CA certificates.

Figure 33 Screen that lists the CA certificates for a Nokia FastMile 4G Receiver managed by the Nokia Altiplano FastMile Controller

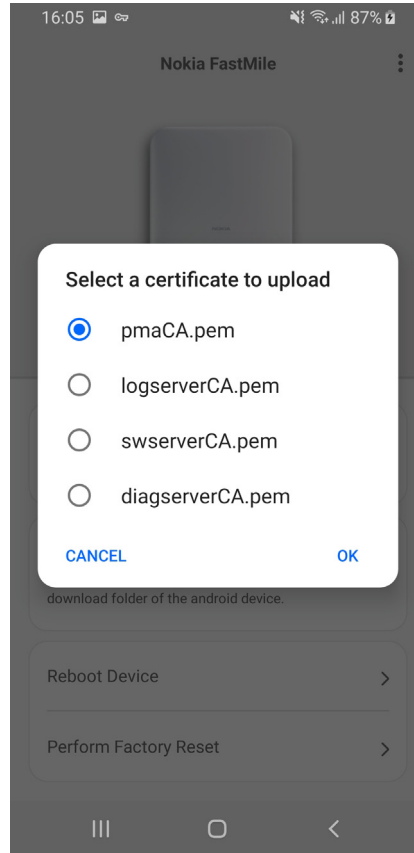

The following CA certificates are supported for a Nokia FastMile 4G Receiver managed by the Nokia Altiplano FastMile Controller:

- pmaCA.pem (used for authenticating the Nokia Altiplano FastMile Controller)
- logserverCA.pem (used for authenticating the log server)
- swserverCA.pem (used for authenticating the software upgrade server)
- diagserverCA.pem (used for authenticating the optional diagnostics server)

iii Figure 34 shows the screen that indicates that uploading of the CA certificates was successful.

Figure 34 Screen indicating that uploading of the CA certificates was successful for a Nokia FastMile 4G Receiver managed by the Nokia Altiplano FastMile Controller

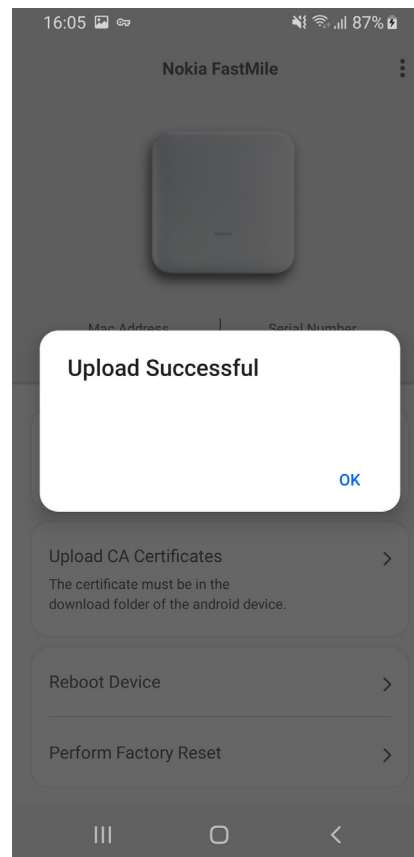

Tap on "Ok" to clear the message.

- 10** You can reboot a Nokia FastMile 4G Receiver managed by the Nokia Altiplano FastMile Controller through NETCONF by tapping on the "Reboot Device" option.

Figure 35 shows the "Reboot Device" option.

Figure 35 Screen showing the “Reboot Device” option for a Nokia FastMile 4G Receiver managed by the Nokia Altiplano FastMile Controller

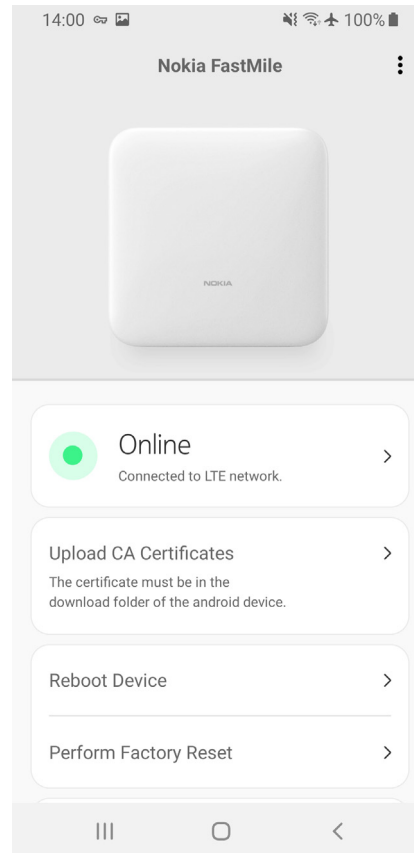

The screen shows the reboot message indicating that the Bluetooth connection will be interrupted and that you will be disconnected.

Figure 36 shows the screen that has the reboot message.

Figure 36 Screen showing the reboot message for a Nokia FastMile 4G Receiver managed by the Nokia Altiplano FastMile Controller

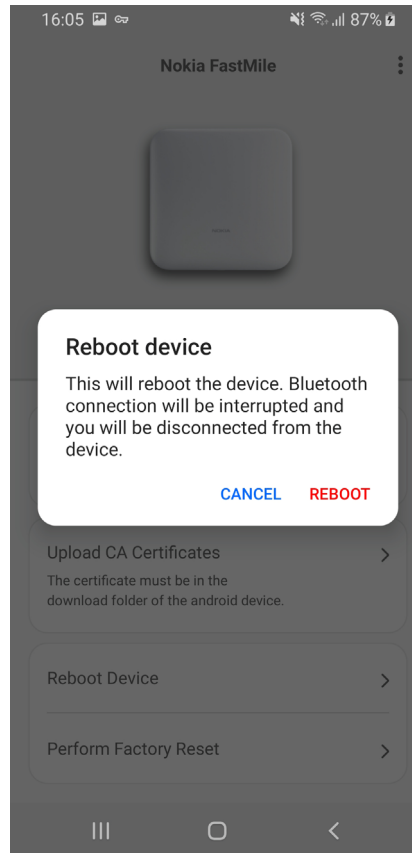

Press the Reboot option if you want to proceed with the reboot, or press the Cancel option.

If you pressed the Reboot option, press OK.

- 11** You can change the configuration settings for a Nokia FastMile 4G Receiver managed by the Nokia Altiplano FastMile Controller through NETCONF to the default factory load settings by tapping on the "Perform Factory Reset" option.

Figure 37 shows the "Perform Factory Reset" option.

Figure 37 Screen showing the “Perform Factory Reset” option for a Nokia FastMile 4G Receiver managed by the Nokia Altiplano FastMile Controller

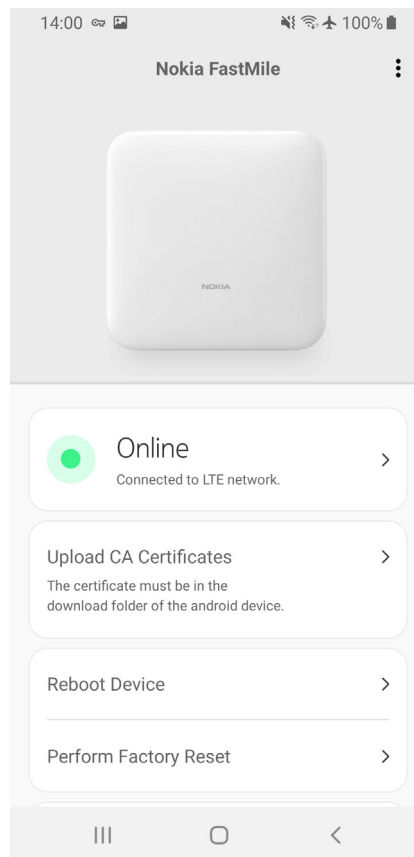

The screen shows the factory reset message indicating that the factory reset will reset the device back to factory settings and that all changes will be lost and that you will be disconnected.

Figure 38 shows the screen that has the factory reset message.

Figure 38 Screen showing the factory reset message for a Nokia FastMile 4G Receiver managed by the Nokia Altiplano FastMile Controller

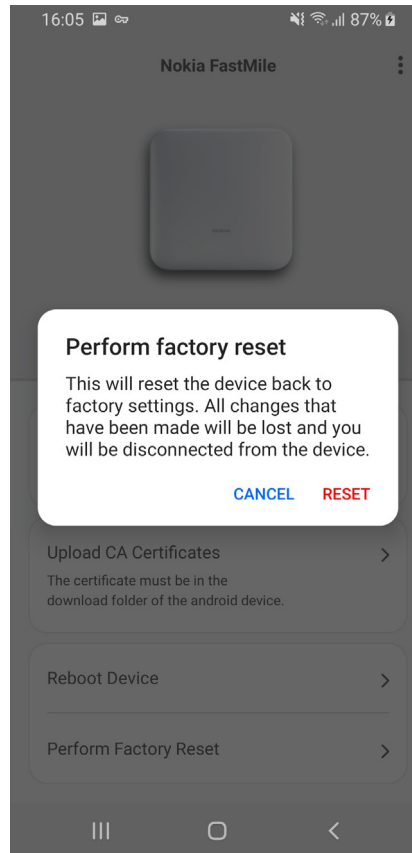

Press the Reset option if you want to proceed with the reset to factory settings, or press the Cancel option.

If you pressed the Reset option, press OK.

13.3 Using the Nokia Wireless app to manage a unit managed by an ACS

If an ACS is being used for remote management of the Nokia FastMile 4G Receiver (through TR-069), you can use the Nokia Wireless app to perform management activities on the Nokia FastMile 4G Receiver after it has been installed, such as viewing information, uploading CA certificates, rebooting, or resetting to factory settings, as described in the following procedure.

This procedure does not involve use of the Nokia Altiplano FastMile Controller.

You will need the QR code that was saved as described during installation of the Nokia FastMile 4G Receiver in order to scan it when logging in to the 4G Receiver through the Nokia Wireless app. Logging in to the Nokia FastMile 4G Receiver also includes the following:

- initiating a Bluetooth connection
- enabling Bluetooth
- allowing the Bluetooth pairing request
- establishing the VPN connection
- entering the username and password



Note — The Bluetooth connection from the Nokia Wireless app towards the Nokia FastMile 4G Receiver is closed after one hour of inactivity in order to preserve Nokia Wireless phone resources. There is a mechanism in place that enables the user to re-establish the Bluetooth connection when he or she re-enters the app.

Procedure 6 To perform management activities

Use the following procedure to use the Nokia Wireless app to perform management activities for a Nokia FastMile 4G Receiver that is managed remotely by an ACS through TR-069.

-
- 1 When you are close to the Nokia FastMile 4G Receiver, connect the mobile phone to the Internet and open the Nokia Wireless app on the phone.

An introductory screen with a video appears.

Figure 39 shows the introductory screen.

Figure 39 **Introductory screen for unit managed by an ACS through TR-069**

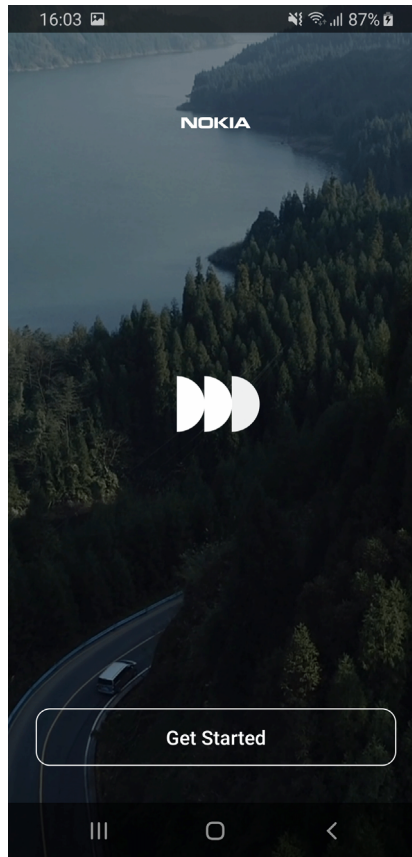

Continue by tapping on “Get started”.

-
- 2 After the introductory screen has cleared, the Nokia Wireless app shows an animation of how to scan the QR code of the Nokia FastMile 4G Receiver so that the app can obtain the MAC address, unique device identifier, enterprise id, and device type of the Nokia FastMile 4G Receiver.

The QR code was provided on a sheet of paper in the shipping package of the Nokia FastMile 4G Receiver. The sheet of paper, or a photograph of it, should have been saved and made available for anyone who later needs to scan the QR code when accessing the Nokia FastMile 4G Receiver.

Figure 40 shows the screen for the prompt to scan the QR code.

Figure 40 Screen with prompt to scan the QR code for unit managed by an ACS through TR-069

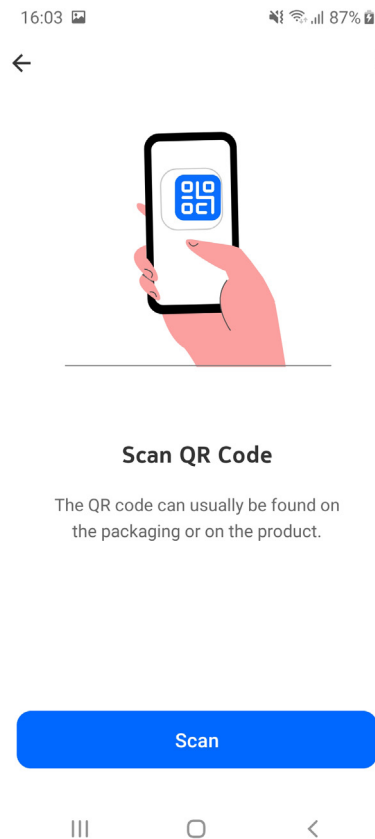

The Nokia Wireless app also provides a way to manually enter all the needed information in order to proceed with the installation without scanning a QR code.

Tap on “Scan” to start the scan of the QR code.

Use the viewfinder of the phone to align with the QR code.

Figure 41 shows the QR code screen.

Figure 41 QR code screen for unit managed by an ACS through TR-069

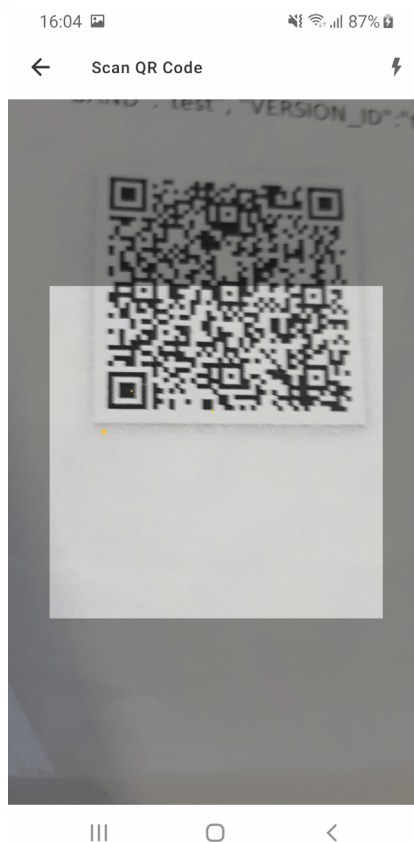

- 3 The Nokia Wireless app displays the screen to install the Nokia FastMile 4G Receiver.
Tap on the "Already Installed?" option.
Figure 42 shows the Already Installed option.

Figure 42 Screen showing the Already Installed option for unit managed by an ACS through TR-069



- 4 The Nokia Wireless app prompts you to connect to the Nokia FastMile 4G Receiver. The connection will be done through Bluetooth in conjunction with a VPN. You will need to be close to the Nokia FastMile 4G Receiver and you will need to have Bluetooth enabled on the mobile phone and accept the pairing request when it appears.

Figure 43 shows the screen to connect to the Nokia FastMile 4G Receiver.

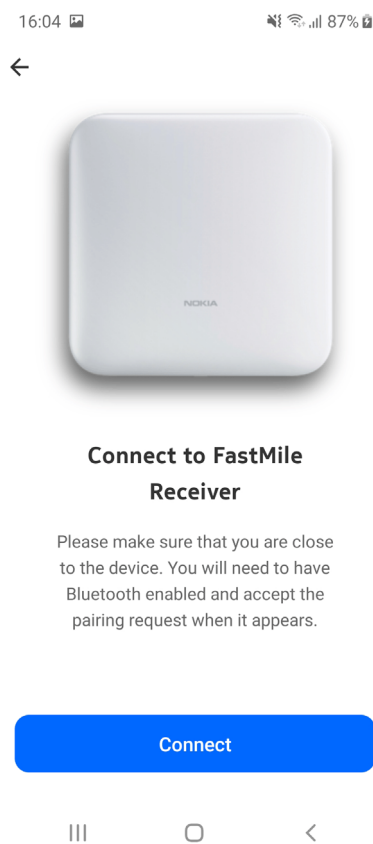
Figure 43 Screen for connecting to the Nokia FastMile 4G Receiver

Connect to the Nokia FastMile 4G Receiver by tapping on “Connect”.

- 5 The Nokia Wireless app prompts you to enable the VPN profile for a secure method to communicate with the Nokia FastMile 4G Receiver.

Figure 44 shows the screen to enable the VPN profile.

Figure 44 Screen for enabling the VPN profile

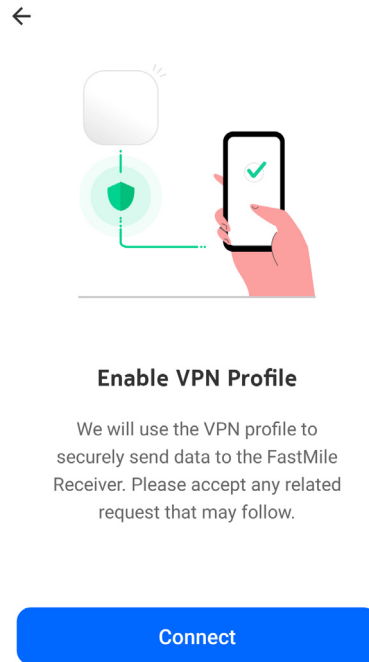

Enable the VPN profile by tapping on “Connect”.

-
- 6** The android system of the mobile phone prompts you to accept the connection request. Figure 45 shows the prompt to accept the connection request.

Figure 45 Prompt for accepting the connection request

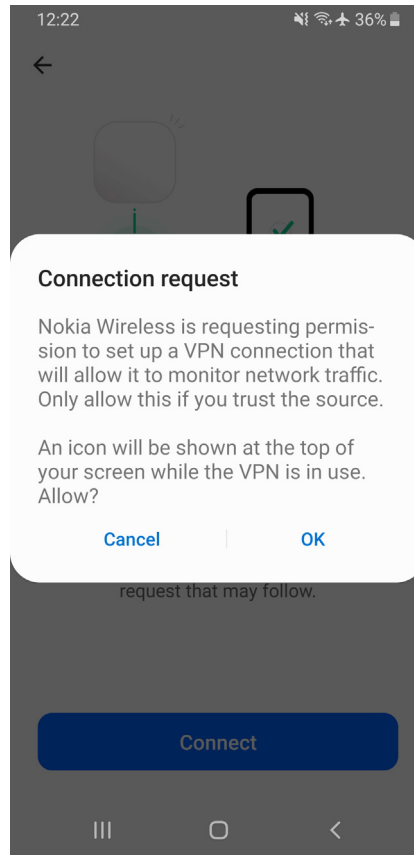

Accept the connection request by tapping on “OK”.

-
- 7 The Nokia Wireless app prompts you to log in to the Nokia FastMile 4G Receiver. You will need to input the username and password for the Nokia FastMile 4G Receiver.

Figure 46 shows the screen to log in to the Nokia FastMile 4G Receiver.

Figure 46 Screen to log in to a Nokia FastMile 4G Receiver managed by an ACS through TR-069

16:04 87%

←

Login to FastMile Receiver

Username
fm2-operator ✓

Password
•••••••• ✓

Log in

☰ ○ <

Log in to the Nokia FastMile 4G Receiver by tapping on “Log in”.

After you have logged in, you can:

- view information for the Nokia FastMile 4G Receiver: see step [8](#)
- upload updated certificates to the Nokia FastMile 4G Receiver: see step [9](#)
- reboot the Nokia FastMile 4G Receiver: see step [10](#)
- change the configuration settings to the default factory load settings (Perform Factory Reset); see step [11](#)

-
- 8 You can view the following information for a Nokia FastMile 4G Receiver managed by an ACS by selecting the Connection Status option of the main screen and scrolling through the screen by swiping up or down:
- LTE cell info:
 - connection state: Does the Nokia FastMile 4G Receiver connect to this cell
 - status: The current operational state of the PDN connection
 - EARFCN: The carrier frequency in the uplink and downlink is designated by the E-UTRA. Absolute Radio Frequency Channel Number (EARFCN) in the range 0 - 65535.
 - PCI: The physical cellid of cell
 - Current signal stats:
 - RSRP: RSRP (Reference Signals Received Power) is a measurement of the received power level in an LTE cell network in dBm
 - RSRQ: RSRQ (Reference Signals Received Quality) is a measurement of the received power quality in an LTE cell network expressed as a ratio
 - RSSI: RSSI (Received Signal Strength Indicator) is a measurement of the power present in a received radio signal by the Nokia FastMile 4G Receiver in dBm
 - SINR: SINR (the Signal-to-Interference-plus-Noise ratio) is used in the LTE network from the Nokia FastMile 4G Receiver side to measure the quality of wireless connections in dB
 - Other stats:
 - bytes sent: the total number of bytes sent on the interface
 - bytes received: the total number of bytes received on the interface

Figure 47 shows an example of the System state screen.