



7368 Intelligent Services Access Manager ONT

7368 ISAM ONT XS-240W-A XS-250WX-A Product Guide

3FE-48631-AAAA-TCZZA

Issue: 01

Nokia is a registered trademark of Nokia Corporation. Other products and company names mentioned herein may be trademarks or tradenames of their respective owners.

The information presented is subject to change without notice. No responsibility is assumed for inaccuracies contained herein.

© 2018 Nokia.

Contains proprietary/trade secret information which is the property of Nokia and must not be made available to, or copied or used by anyone outside Nokia without its written authorization. Not to be used or disclosed except in accordance with applicable agreements.

1 Preface

This preface provides general information about the documentation set for optical network terminals (ONTs).

1.1 Scope

This documentation set provides information about safety, features and functionality, ordering, hardware installation and maintenance, and software installation procedures for the current release.

1.2 Audience

This documentation set is intended for planners, administrators, operators, and maintenance personnel involved in installing, upgrading, or maintaining the ONTs.

1.3 Required knowledge

The reader must be familiar with general telecommunications principles.

1.4 Acronyms and initialisms

The expansions and optional descriptions of most acronyms and initialisms appear in the glossary.

1.5 Assistance and ordering phone numbers

Nokia provides global technical support through regional call centers. Phone numbers for the regional call centers are available at the following URL: <http://support.alcatel-lucent.com>.

For ordering information, contact your Nokia sales representative.

1.6 Nokia quality processes

Nokia's ONT quality practices are in compliance with TL 9000 requirements. These requirements are documented in the Fixed Networks Quality Manual 3FQ-30146-6000-QRZZA. The quality practices adequately ensure that technical requirements and customer end-point requirements are met. The customer or its representatives may be allowed to perform on-site quality surveillance audits, as agreed upon during contract negotiations

1.7 Safety information

For safety information, see the appropriate safety guidelines chapter.

1.8 Documents

Documents are available using ALED or OLCS.

Procedure 1 To download a ZIP file package of the customer documentation

-
- 1 Navigate to <http://support.alcatel-lucent.com> and enter your user name and password. If you are a new user and require access to this service, please contact your Nokia sales representative.

 - 2 From the Technical Content for drop-down menu, choose the product.

 - 3 Click on Downloads: Electronic Delivery.

 - 4 Choose Documentation from the drop-down menu and click Next.

 - 5 Select the image from the drop-down menu and click Next.

 - 6 Follow the on-screen directions to download the file.
-

Procedure 2 To access individual documents

Individual PDFs of customer documents are also accessible through the Nokia Customer Support website.

- 1 Navigate to <http://support.alcatel-lucent.com> and enter your user name and password. If you are a new user and require access to this service, please contact your Nokia sales representative.
 - 2 From the Technical Content for drop-down menu, choose the product.
 - 3 Click on Manuals and Guides to display a list of customer documents by title and part number. You can filter this list using the Release drop-down menu.
 - 4 Click on the PDF to open or save the file.
-

1.9 Special information

The following are examples of how special information is presented in this document.



Danger — Danger indicates that the described activity or situation may result in serious personal injury or death; for example, high voltage or electric shock hazards.



Warning — Warning indicates that the described activity or situation may, or will, cause equipment damage or serious performance problems.



Caution — Caution indicates that the described activity or situation may, or will, cause service interruption.



Note — A note provides information that is, or may be, of special interest.

1.9.1 Procedures with options or substeps

When there are options in a procedure, they are identified by letters. When there are required substeps in a procedure, they are identified by roman numerals.

Procedure 3 Example of options in a procedure

At step 1, you can choose option a or b. At step 2, you must do what the step indicates.

-
- 1 This step offers two options. You must choose one of the following:
 - a This is one option.
 - b This is another option.
-

- 2 You must perform this step.
-

Procedure 4 Example of required substeps in a procedure

At step 1, you must perform a series of substeps within a step. At step 2, you must do what the step indicates.

-
- 1 This step has a series of substeps that you must perform to complete the step. You must perform the following substeps:
 - i This is the first substep.
 - ii This is the second substep.
 - iii This is the third substep.
-

- 2 You must perform this step.
-

1.10 Multiple PDF document search

You can use Adobe Reader Release 6.0 and later to search multiple PDF files for a common term. Adobe Reader displays the results in a single display panel. The results are grouped by PDF file, and you can expand the entry for each file.



Note — The PDF files in which you search must be in the same folder.

Procedure 5 To search multiple PDF files for a common term

-
- 1 Open Adobe Acrobat Reader.

 - 2 Choose Edit→Search from the Acrobat Reader main menu. The Search PDF panel appears.

 - 3 Enter the search criteria.

 - 4 Click on the All PDF Documents In radio button.

 - 5 Select the folder in which to search using the drop-down menu.

 - 6 Click on the Search button.

Acrobat Reader displays the search results. You can expand the entries for each document by clicking on the + symbol.

Table of contents

1	Preface	3
1.1	Scope	3
1.2	Audience.....	3
1.3	Required knowledge.....	3
1.4	Acronyms and initialisms	3
1.5	Assistance and ordering phone numbers	3
1.6	Nokia quality processes.....	4
1.7	Safety information.....	4
1.8	Documents	4
1.9	Special information	5
1.9.1	Procedures with options or substeps.....	6
1.10	Multiple PDF document search	7
2	ETSI ONT safety guidelines	17
2.1	Safety instructions	17
2.1.1	Safety instruction boxes	17
2.1.2	Safety-related labels.....	18
2.2	Safety standards compliance	19
2.2.1	EMC, EMI, and ESD compliance.....	19
2.2.2	Equipment safety standard compliance.....	19
2.2.3	Environmental standard compliance	20
2.2.4	Laser product standard compliance	20
2.2.5	Resistibility requirements compliance	20
2.2.6	Acoustic noise emission standard compliance	20
2.3	Electrical safety guidelines	20
2.3.1	Power supplies	21
2.3.2	Cabling	21
2.3.3	Protective earth	21
2.4	ESD safety guidelines	21
2.5	Laser safety guidelines.....	21
2.5.1	Laser classification	22
2.5.1.1	Laser warning labels.....	22
2.5.2	Transmit optical output	24
2.5.3	Normal laser operation	24
2.5.4	Location class.....	25
2.6	Environmental requirements.....	25
3	ETSI environmental and CRoHS guidelines	27
3.1	Environmental labels	27
3.1.1	Overview.....	27
3.1.2	Environmental related labels	27
3.1.2.1	Products below Maximum Concentration Value (MCV) label.....	27
3.1.2.2	Products containing hazardous substances above Maximum Concentration Value (MCV) label.....	28
3.2	Hazardous Substances Table (HST).....	29
3.3	Other environmental requirements	29

3.3.1	ONT environmental requirements	29
3.3.2	Storage	29
3.3.3	Transportation	30
3.3.4	Stationary use.....	30
3.3.5	Thermal limitations	30
3.3.6	Material content compliance.....	30
3.3.7	End-of-life collection and treatment.....	31
4	ANSI ONT safety guidelines	33
4.1	Safety instructions	33
4.1.1	Safety instruction boxes in customer documentation	33
4.1.2	Safety-related labels.....	34
4.2	Safety standards compliance	35
4.2.1	EMC, EMI, and ESD standards compliance.....	36
4.2.2	Equipment safety standard compliance.....	36
4.2.3	Environmental standards compliance.....	37
4.2.4	Laser product standards compliance.....	37
4.2.5	Resistibility requirements compliance	38
4.3	Laser safety guidelines.....	38
4.3.1	Laser warning labels.....	38
4.3.2	Laser classification	40
4.3.3	Transmit optical output	41
4.3.4	Normal laser operation	41
4.3.5	Location class.....	41
4.4	Electrical safety guidelines	42
4.4.1	Power supplies	42
4.4.2	Cabling	42
4.4.3	Protective earth	42
4.5	ESD safety guidelines	42
4.6	Environmental requirements.....	43
5	XS-240W-A and XS-250WX-A unit data sheet	45
5.1	XS-240W-A and XS-250WX-A part numbers and identification	45
5.2	XS-240W-A and XS-250WX-A general description.....	48
5.2.1	TR69 authentication using TLS and CA certificates	51
5.3	XS-240W-A and XS-250WX-A software and installation feature support.....	52
5.4	XS-240W-A and XS-250WX-A interfaces and interface capacity.....	52
5.4.1	XS-240W-A and XS-250WX-A connections and components	53
5.5	XS-240W-A and XS-250WX-A LEDs	53
5.6	XS-240W-A and XS-250WX-A detailed specifications	55
5.7	XS-240W-A and XS-250WX-A GEM ports and T-CONTs.....	56
5.8	XS-240W-A and XS-250WX-A functional blocks.....	57
5.9	XS-240W-A and XS-250WX-A standards compliance	61
5.9.1	Responsible party	61
5.9.2	Energy-related products standby and off modes compliance.....	62
5.9.3	FCC statement	62
5.9.4	FCC Radiation Exposure Statement	63
5.10	XS-240W-A and XS-250WX-A special considerations.....	63
5.10.1	Wi-Fi service.....	63

5.10.1.1	Wi-Fi physical features	63
5.10.1.2	Wi-Fi standards and certifications	64
5.10.1.3	Wi-Fi GUI features.....	64
5.10.2	XS-240W-A and XS-250WX-A ONT considerations and limitations	64
6	Install an XS-240W-A or XS-250WX-A indoor ONT	65
6.1	Purpose	65
6.2	General.....	65
6.3	Prerequisites.....	65
6.4	Recommended tools.....	65
6.5	Safety information.....	66
6.6	Procedure	67
7	Replace an XS-240W-A or XS-250WX-A indoor ONT.....	73
7.1	Purpose	73
7.2	General.....	73
7.3	Prerequisites.....	73
7.4	Recommended tools.....	73
7.5	Safety information.....	74
7.6	Procedure	75
8	Configure an XS-240W-A or XS-250WX-A indoor ONT	79
8.1	General.....	79
8.2	HGU mode GUI configuration.....	79
8.2.1	Login.....	79
8.2.2	Device and connection status.....	80
8.2.3	Network configuration.....	94
8.2.4	Security configuration	113
8.2.5	Application configuration	122
8.2.6	Maintenance	130
8.2.7	RG troubleshooting counters.....	142

List of figures

2	ETSI ONT safety guidelines	17
Figure 1	PSE certification	19
Figure 2	Laser product label	22
Figure 3	Laser classification label.....	23
Figure 4	Laser warning labels.....	24
3	ETSI environmental and CRoHS guidelines	27
Figure 5	Products below MCV value label.....	28
Figure 6	Products above MCV value label	28
Figure 7	Recycling/take back/disposal of product symbol	31
4	ANSI ONT safety guidelines	33
Figure 8	Sample safety label on the ONT equipment.....	35
Figure 9	Sample laser product label showing CDRH 21 CFR compliance	37
Figure 10	Laser product label	39
Figure 11	Laser classification label.....	39
Figure 12	Laser warning labels.....	40
Figure 13	Sample laser product safety label on the ONT equipment.....	41
5	XS-240W-A and XS-250WX-A unit data sheet	45
Figure 14	XS-240W-A or XS-250WX-A in wall mounting bracket	49
Figure 15	XS-240W-A ONT connections.....	50
Figure 16	XS-250WX-A ONT connections	50
Figure 17	XS-250WX-A indoor ONT LEDs.....	54
Figure 18	Functional blocks for XS-240W-A ONT	58
Figure 19	Functional blocks for XS-250WX-A ONT.....	59
Figure 20	XS-240W-A and XS-250WX-A ONT SoC hardware block	60
6	Install an XS-240W-A or XS-250WX-A indoor ONT	65
Figure 21	XS-240W-A and XS-250WX-A wall mounting bracket	68
Figure 22	XS-240W-A and XS-250WX-A ONT in wall mounting bracket	68
Figure 23	XS-240W-A ONT connections.....	69
Figure 24	XS-250WX-A connections	69
7	Replace an XS-240W-A or XS-250WX-A indoor ONT	73
Figure 25	XS-240W-A ONT connections.....	75
Figure 26	XS-250WX-A ONT connections	76
8	Configure an XS-240W-A or XS-250WX-A indoor ONT	79
Figure 27	Web login window.....	80
Figure 28	Device Information window.....	81
Figure 29	LAN status window	83
Figure 30	WAN status window.....	85
Figure 31	WAN status IPv6 window	87
Figure 32	Home networking information window	89
Figure 33	Optics module status window	90
Figure 34	Statistics window	92
Figure 35	Voice Information window.....	93

Figure 36	LAN network window	95
Figure 37	LAN IPv6 network window	97
Figure 38	WAN network window	99
Figure 39	WAN DHCP window	100
Figure 40	Wireless 2.4GHz network window	102
Figure 41	Wireless 5GHz network window	105
Figure 42	Wireless Schedule network window	107
Figure 43	IP Routing network window	108
Figure 44	DNS network window	109
Figure 45	TR-069 network window	111
Figure 46	QoS Config window (L2).....	112
Figure 47	Firewall window	114
Figure 48	MAC filter window	115
Figure 49	IP filter window	116
Figure 50	URL Filter window	118
Figure 51	DMZ and ALG window.....	119
Figure 52	Access Control window	121
Figure 53	Port forwarding window	123
Figure 54	DDNS window	124
Figure 55	NTP window	125
Figure 56	USB window	126
Figure 57	UPnP and DLNA window.....	128
Figure 58	Voice setting window	129
Figure 59	Password window	132
Figure 60	LOID Config window.....	133
Figure 61	SLID configuration window	134
Figure 62	Device management window.....	135
Figure 63	Backup and Restore window	136
Figure 64	Firmware upgrade window	137
Figure 65	Reboot window	138
Figure 66	Factory default window.....	139
Figure 67	Diagnose window	140
Figure 68	Log window.....	141
Figure 69	RG Troubleshooting Counters window.....	143

List of tables

2	ETSI ONT safety guidelines	17
Table 1	Safety labels	18
4	ANSI ONT safety guidelines	33
Table 2	Safety labels	34
5	XS-240W-A and XS-250WX-A unit data sheet	45
Table 3	Identification of XS-240W-A indoor ONTs	45
Table 4	Identification of XS-250WX-A indoor ONTs	46
Table 5	XS-240W-A and XS-250WX-A power supply	48
Table 6	XS-240W-A and XS-250WX-A comparison	48
Table 7	XS-240W-A and XS-250WX-A indoor ONT interface connection capacity	52
Table 8	XS-240W-A and XS-250WX-A indoor ONT physical connections	53
Table 9	XS-240W-A and XS-250WX-A indoor ONT LEDs	54
Table 10	XS-240W-A and XS-250WX-A indoor ONT physical specifications	55
Table 11	XS-240W-A and XS-250WX-A indoor ONT power consumption specifications	56
Table 12	XS-240W-A and XS-250WX-A indoor ONT environmental specifications	56
Table 13	XS-240W-A and XS-250WX-A indoor ONT capacity for GEM ports and T-CONTs	57
Table 14	Responsible party contact information	62
Table 15	XS-240W-A and XS-250WX-A ONT considerations and limitations	64
8	Configure an XS-240W-A or XS-250WX-A indoor ONT	79
Table 16	Device Information parameters	81
Table 17	LAN status parameters	83
Table 18	WAN status parameters	85
Table 19	WAN status IPv6 parameters	87
Table 20	Home networking parameters	89
Table 21	Optics module status parameters	91
Table 22	Voice Information parameters	93
Table 23	LAN network parameters	95
Table 24	LAN IPv6 network parameters	97
Table 25	WAN network parameters	99
Table 26	WAN DHCP parameters	101
Table 27	Wireless 2.4GHz network parameters	102
Table 28	Wireless 5GHz network parameters	105
Table 29	IP Routing network parameters	108
Table 30	DNS network parameters	110
Table 31	TR-069 network parameters	111
Table 32	QoS Config parameters	113
Table 33	Firewall parameters	115
Table 34	MAC filter parameters	116
Table 35	IP filter parameters	117
Table 36	URL Filter parameters	118

Table 37	DMZ and ALG parameters	119
Table 38	Access control parameters	121
Table 39	Port forwarding parameters	123
Table 40	DDNS parameters	124
Table 41	USB parameters	127
Table 42	Voice setting parameters.....	130
Table 43	Password parameters.....	132
Table 44	LOID configuration parameters	133
Table 45	SLID configuration parameters.....	134
Table 46	Device management parameters	135
Table 47	RG Troubleshooting Counters parameters.....	143

2 ETSI ONT safety guidelines

This chapter provides information about the mandatory regulations that govern the installation and operation of the optical network terminals (ONTs).

2.1 Safety instructions

This section describes the safety instructions that are provided in the ONT customer documentation and on the equipment.

2.1.1 Safety instruction boxes

The safety instruction boxes are provided in the ONT customer documentation. Observe the instructions to meet safety requirements.

The following is an example of the Danger box.



Danger — Possibility of personal injury.

The Danger box indicates that the described activity or situation may pose a threat to personal safety. It calls attention to a situation or procedure which, if not correctly performed or adhered to, may result in death or serious physical harm.

Do not proceed beyond a Danger box until the indicated conditions are fully understood and met.

The following is an example of the Warning box.



Warning 1 — Possibility of equipment damage.

Warning 2 — Possibility of data loss.

The Warning box indicates that the described activity or situation may, or will, cause equipment damage, loss of data, or serious performance problems. It identifies a possible equipment-damaging situation or provides essential information to avoid the degradation of system operations or data.

Do not proceed beyond a warning until the indicated conditions are fully understood and met.

The following is an example of the Caution box.



Caution 1 — Possibility of service interruption.

Caution 2 — Service interruption.

The Caution box indicates that the described activity or situation may, or will, cause service interruption.

Do not proceed beyond a caution until the indicated conditions are fully understood and met.

The following is an example of the Note box.



Note — Information of special interest.

The Note box provides information that assists the personnel working with ONTs. It does not provide safety-related instructions.

2.1.2 Safety-related labels

The ONT equipment is labeled with the specific safety instructions and compliance information that is related to a variant of the ONT. Observe the instructions on the safety labels.

Table 1 provides sample safety labels on the ONT equipment.

Table 1 Safety labels

Description	Label text
ESD warning	Caution: This assembly contains an electrostatic sensitive device.
Laser classification	Class 1 laser product
PSE marking	These power supplies are Japan PSE certified and compliant with Japan VCCI emissions standards.

Figure 1 shows the PSE certification.

Figure 1 PSE certification

 Warning	This is a Class B product based on the standard of the Voluntary Control Council for Interference from Information Technology Equipment (VCCI). If this is used near a radio or television receiver in a domestic environment, it may cause radio interference. Install and use the equipment according to the instruction manual.
警告	VCCI準拠クラスB機器（日本） この機器は、Information Technology EquipmentのVoluntary Control Council for Interference (VCCI)の規格に準拠したクラスB製品です。この機器をラジオやテレビ受信機の近くで使用した場合、混信が発生する恐れがあります。本機器の設置および使用に際しては、取扱説明書に従ってください。

19841

2.2 Safety standards compliance

This section describes the ONT compliance with the European safety standards.

2.2.1 EMC, EMI, and ESD compliance

The ONT equipment complies with the following EMC, EMI, and ESD requirements:

- EN 300-328 v1.9.1 wide band data transmission standards for 2.4GHz bands
- EN 300-386 V1.5.1: Electromagnetic Compatibility and Radio Spectrum Matters (ERM): Telecommunications Network Equipment; Electromagnetic Compatibility (EMC) requirements; Electrostatic Discharge (ESD) requirements
- EN 55022 (2006): Class B, Information Technology Equipment, Radio Disturbance Characteristics, limits and methods of measurement
- EN 55024 (2010): Information Technology Equipment, Immunity Characteristics, limits and methods of measurement
- European Council Directive 2004/108/EC
- EN 300-386 V1.4.1: 2008
- EN 55022:2006 Class B (ONTs)

2.2.2 Equipment safety standard compliance

The ONT equipment complies with the requirements of EN 60950-1, Safety of Information Technology Equipment for use in a restricted location (per R-269).

2.2.3 Environmental standard compliance

The ONT equipment complies with the EN 300 019 European environmental standards.

2.2.4 Laser product standard compliance

For most ONTs, the ONT equipment complies with EN 60825-1 and IEC 60825-2 for laser products. If there is an exception to this compliance regulation, you can find this information in the standards compliance section of the unit data sheet in this Product Guide.

2.2.5 Resistibility requirements compliance

The ONT equipment complies with the requirements of ITU Recommendation K.21 for resistibility of telecommunication equipment installed in customer premises to over voltage and overcurrents.

2.2.6 Acoustic noise emission standard compliance

The ONT equipment complies with EN 300 753 acoustic noise emission limit and test methods.

2.3 Electrical safety guidelines

This section provides the electrical safety guidelines for the ONT equipment.



Note 1 — The ONTs comply with the U.S. National Electrical Code. However, local electrical authorities have jurisdiction when there are differences between the local and U.S. standards.

Note 2 — The ONTs comply with BS EN 61140.

2.3.1 Power supplies

The use of any non-Nokia approved power supplies or power adapters is not supported or endorsed by Nokia. Such use will void any warranty or support contract with Nokia. Such use greatly increases the danger of damage to equipment or property.

2.3.2 Cabling

The following are the guidelines regarding cables used for the ONT equipment:

- All cables must be approved by the relevant national electrical code.
- The cables for outdoor installation of ONTs must be suitable for outdoor use.
- POTS wiring run outside the subscriber premises must comply with the requirements of local electrical codes. In some markets, the maximum allowed length of the outside run is 140 feet (43 m). If the outside run is longer, NEC requires primary protection at both the exit and entry points for the wire.

2.3.3 Protective earth

Earthing and bonding of the ONTs must comply with the requirements of local electrical codes.

2.4 ESD safety guidelines

The ONT equipment is sensitive to ESD. Operations personnel must observe the following ESD instructions when they handle the ONT equipment.



Caution — This equipment is ESD sensitive. Proper ESD protections should be used when you enter the TELCO Access portion of the ONT.

During installation and maintenance, service personnel must wear wrist straps to prevent damage caused by ESD.

2.5 Laser safety guidelines

Observe the following instructions when you perform installation, operations, and maintenance tasks on the ONT equipment.

Only qualified service personnel who are extremely familiar with laser radiation hazards should install or remove the fiber optic cables and units in this system.



Danger — There may be invisible laser radiation at the fiber optic cable when the cable is removed from the connector. Avoid direct exposure to the laser beam.

Observe the following danger for laser hazard. Eyes can be damaged when they are exposed to a laser beam. Take necessary precautions before you plug in the optical modules.



Danger — Possibility of equipment damage. Risk of eye damage by laser radiation.

2.5.1 Laser classification

The ONT is classified as a Class 1 laser product based on its transmit optical output.

2.5.1.1 Laser warning labels

The following figures show the labels related to laser product, classification and warning.

Figure 2 shows a laser product label.

Figure 2 Laser product label



18455

Figure 3 shows a laser classification label. Laser classification labels may be provided in other languages.

Figure 3 Laser classification label

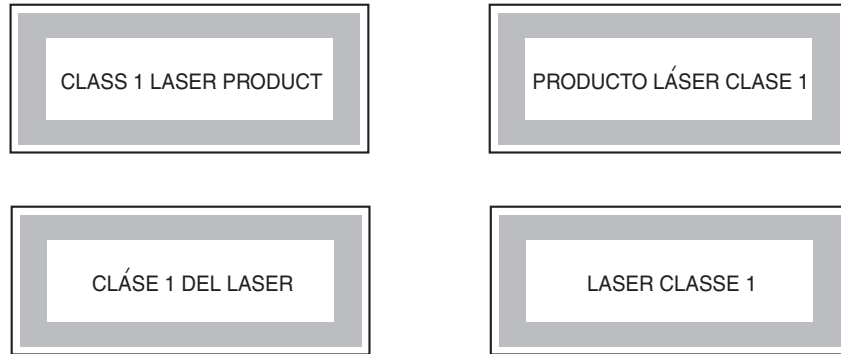

18992

Figure 4 shows a laser warning label and an explanatory label for laser products. Labels and warning may be provided in other languages. The explanatory label provides the following information:

- a warning that calls attention to the invisible laser radiation
- an instruction against staring into the beam or viewing directly with optical instruments
- wavelength
- normal output power
- maximum output power

Figure 4 Laser warning labels



18993

2.5.2 Transmit optical output

The maximum transmit optical output of an ONT is +5 dBm.

2.5.3 Normal laser operation

In normal operation, fiber cable laser radiation is always off until it receives signal from the line terminal card.

Eyes can be damaged when they exposed to a laser beam. Operating personnel must observe the instructions on the laser explanatory label before plugging in the optical module.



Danger — Risk of eye damage by laser radiation.

2.5.4 Location class

Use cable supports and guides to protect the receptacles from strain.

2.6 Environmental requirements

See the ONT technical specification documentation for more information about temperature ranges.

During operation in the supported temperature range, condensation inside the ONT caused by humidity is not an issue. To avoid condensation caused by rapid changes in temperature and humidity, Nokia recommends:

- The door of the ONT not be opened until temperature inside and outside the enclosure has stabilized.
- If the door of the ONT must be opened after a rapid change in temperature or humidity, use a dry cloth to wipe down the metal interior to prevent the risk of condensation.
- When high humidity is present, installation of a cover or tent over the ONT helps prevent condensation when the door is opened.

3 ETSI environmental and CRoHS guidelines

This chapter provides information about the ETSI environmental China Restriction of Hazardous Substances (CRoHS) regulations that govern the installation and operation of the optical line termination (OLT) and optical network termination (ONT) systems. This chapter also includes environmental operation parameters of general interest.

3.1 Environmental labels

This section describes the environmental instructions that are provided with the customer documentation, equipment, and location where the equipment resides.

3.1.1 Overview

CRoHS is applicable to Electronic Information Products (EIP) manufactured or sold and imported in the territory of the mainland of the People's Republic of China. EIP refers to products and their accessories manufactured by using electronic information technology, including electronic communications products and such subcomponents as batteries and cables.

3.1.2 Environmental related labels

Environmental labels are located on appropriate equipment. The following are sample labels.

3.1.2.1 Products below Maximum Concentration Value (MCV) label

Figure 5 shows the label that indicates a product is below the maximum concentration value, as defined by standard SJ/T11363-2006 (Requirements for Concentration Limits for Certain Hazardous Substances in Electronic Information Products). Products with this label are recyclable. The label may be found in this documentation or on the product.

Figure 5 Products below MCV value label



18986

3.1.2.2 Products containing hazardous substances above Maximum Concentration Value (MCV) label

Figure 6 shows the label that indicates a product is above the maximum concentration value, as defined by standard SJ/T11363-2006 (Requirements for Concentration Limits for Certain Hazardous Substances in Electronic Information Products). The number contained inside the label indicates the Environment-Friendly User Period (EFUP) value. The label may be found in this documentation or on the product.

Figure 6 Products above MCV value label



Together with major international telecommunications equipment companies, Nokia has determined it is appropriate to use an EFUP of 50 years for network infrastructure equipment and an EFUP of 20 years for handsets and accessories. These values are based on manufacturers' extensive practical experience of the design, manufacturing, maintenance, usage conditions, operating environments, and physical condition of infrastructure and handsets after years of service. The values reflect minimum values and refer to products operated according to the intended use conditions. See "[Hazardous Substances Table \(HST\)](#)" for more information.

3.2 Hazardous Substances Table (HST)

This section describes the compliance of the OLT and ONT equipment to the CRoHS standard when the product and subassemblies contain hazardous substances beyond the MCV value. This information is found in this user documentation where part numbers for the product and subassemblies are listed. It may be referenced in other OLT and ONT documentation.

In accordance with the People's Republic of China Electronic Industry Standard Marking for the Control of Pollution Caused by Electronic Information Products (SJ/T11364-2006), customers may access the Nokia Hazardous Substance Table, in Chinese, from the following location:

- <http://www.nokia-sbell.com/wwwroot/images/upload/private/1/media/ChinaRoHS.pdf>

3.3 Other environmental requirements

Observe the following environmental requirements when handling the P-OLT or ONT equipment.

3.3.1 ONT environmental requirements

See the ONT technical specification documentation for more information about temperature ranges.

3.3.2 Storage

According to ETS 300-019-1-1 - Class 1.1, storage of OLT equipment must be in Class 1.1, weather-protected, temperature-controlled locations.

3.3.3 Transportation

According to EN 300-019-1-2 - Class 2.3, transportation of the OLT equipment must be in packed, public transportation with no rain on packing allowed.

3.3.4 Stationary use

According to EN 300-019-1-3 - Class 3.1/3.2/3.E, stationary use of OLT equipment must be in a temperature-controlled location, with no rain allowed, and with no condensation allowed.

3.3.5 Thermal limitations

When the OLT is installed in the CO or CEV, install air filters on the P-OLT. The thermal limitations for OLT operation in a CO or CEV are:

- operating temperature: 5°C to 40°C (41°F to 104°F)
- short-term temperature: -5°C to 50°C (23°F to 122°F)
- operating relative humidity: 5% to 85%
- short-term relative humidity: 5% to 95%, but not to exceed 0.024 kg of water/kg

3.3.6 Material content compliance

European Union (EU) Directive 2002/95/EC, "Restriction of the use of certain Hazardous Substances" (RoHS), restricts the use of lead, mercury, cadmium, hexavalent chromium, and certain flame retardants in electrical and electronic equipment. This Directive applies to electrical and electronic products placed on the EU market after 1 July 2006, with various exemptions, including an exemption for lead solder in network infrastructure equipment. Nokia products shipped to the EU after 1 July 2006 comply with the EU RoHS Directive.

Nokia has implemented a material/substance content management process. The process is described in: Nokia process for ensuring RoHS Compliance (1AA002660031ASZZA). This ensures compliance with the European Union Directive 2011/65/EU on the Restriction of the Use of Certain Hazardous Substances in Electrical and Electronic Equipment (RoHS2). With the process equipment is assessed in accordance with the Harmonised Standard EN50581:2012 (CENELEC) on Technical documentation for the assessment of electrical and electronic products with respect to the restriction of hazardous substances.

3.3.7 End-of-life collection and treatment

Electronic products bearing or referencing the symbol shown in Figure 7, when put on the market within the European Union (EU), shall be collected and treated at the end of their useful life, in compliance with applicable EU and local legislation. They shall not be disposed of as part of unsorted municipal waste. Due to materials that may be contained in the product, such as heavy metals or batteries, the environment and human health may be negatively impacted as a result of inappropriate disposal.



Note — In the European Union, a solid bar under the symbol for a crossed-out wheeled bin indicates that the product was put on the market after 13 August 2005.

Figure 7 Recycling/take back/disposal of product symbol



At the end of their life, the OLT and ONT products are subject to the applicable local legislations that implement the European Directive 2012/19EU on waste electrical and electronic equipment (WEEE).

There can be different requirements for collection and treatment in different member states of the European Union.

In compliance with legal requirements and contractual agreements, where applicable, Nokia will offer to provide for the collection and treatment of Nokia products bearing the logo shown in Figure 7 at the end of their useful life, or products displaced by Nokia equipment offers. For information regarding take-back of equipment by Nokia, or for more information regarding the requirements for recycling/disposal of product, contact your Nokia account manager or Nokia take back support at sustainability.global@nokia.com.

4 ANSI ONT safety guidelines

This chapter provides information about the mandatory regulations that govern the installation and operation of the optical network terminals or units (ONTs or ONUs) in the North American or ANSI market.

4.1 Safety instructions

This section describes the safety instructions that are provided in the ONT customer documentation and on the equipment.

4.1.1 Safety instruction boxes in customer documentation

The safety instruction boxes are provided in the ONT customer documentation. Observe the instructions to meet safety requirements.

The following is an example of the Danger box.



Danger — Possibility of personal injury.

The Danger box indicates that the described activity or situation may pose a threat to personal safety. It calls attention to a situation or procedure which, if not correctly performed or adhered to, may result in death or serious physical harm.

Do not proceed beyond a Danger box until the indicated conditions are fully understood and met.

The following is an example of the Warning box.



Warning 1 — Possibility of equipment damage.

Warning 2 — Possibility of data loss.

The Warning box indicates that the described activity or situation may, or will, cause equipment damage, loss of data, or serious performance problems. It identifies a possible equipment-damaging situation or provides essential information to avoid the degradation of system operations or data.

Do not proceed beyond a warning until the indicated conditions are fully understood and met.

The following is an example of the Caution box.



Caution 1 — Possibility of service interruption.

Caution 2 — Service interruption.

The Caution box indicates that the described activity or situation may, or will, cause service interruption.

Do not proceed beyond a caution until the indicated conditions are fully understood and met.

The following is an example of the Note box.



Note — Information of special interest.

The Note box provides information that assists the personnel working with ONTs. It does not provide safety-related instructions.

4.1.2 Safety-related labels

The ONT equipment is labeled with specific safety compliance information and instructions that are related to a variant of the ONT. Observe the instructions on the safety labels.

Table 2 provides examples of the text in the various ONT safety labels.

Table 2 Safety labels

Description	Label text
UL compliance	Communication service equipment US listed. Type 3R enclosure - Rainproof.
TUV compliance	Type 3R enclosure - Rainproof.
ESD warning	Caution: This assembly contains electrostatic sensitive device.
Laser classification	Class 1 laser product
Laser product compliance	This laser product conforms to all applicable standards of 21 CFR 1040.10 at date of manufacture.
FCC standards compliance	Tested to comply with FCC standards for home or office use.
CDRH compliance	Complies with 21 CFR 1040.10 and 1040.11 except for deviations pursuant to Laser Notice No. 50, dated June 24, 2007

(1 of 2)

Description	Label text
Operation conditions	This device complies with Part 15 of the FCC Rules. Operation is subject to the following two conditions: (1) this device may not cause harmful interference, and (2) this device must accept any interference received, including interference that may cause undesired operation.
Canadian standard compliance (modular ONT)	This Class A digital apparatus complies with Canadian ICES-003.
Canadian standard compliance (outdoor ONT)	This Class B digital apparatus complies with Canadian ICES-003.
CE marking	There are various CE symbols for CE compliance.

(2 of 2)

Figure 8 shows a sample safety label on the ONT equipment.

Figure 8 Sample safety label on the ONT equipment

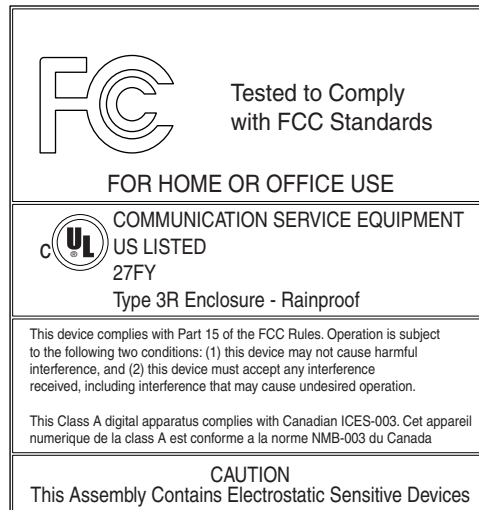

18533

4.2 Safety standards compliance

This section describes the ONT compliance with North American safety standards.



Warning — Changes or modifications to this unit not expressly approved by the party responsible for compliance could void the user's authority to operate the equipment.

4.2.1 EMC, EMI, and ESD standards compliance

The ONT equipment complies with the following requirements:

- Federal Communications Commission (FCC) CFR 47, Part 15, Subpart B, Class A requirements for OLT equipment
- GR-1089-CORE requirements, including:
 - Section 3 Electromagnetic Interference, Emissions Radiated and Conducted
 - Section 3 Immunity, Radiated and Conducted
 - Section 2 ESD Discharge Immunity: System Level Electrostatic Discharge and EFT Immunity: Electrically Fast Transients

This equipment has been tested and found to comply with the limits for a Class B digital device, pursuant to Part 15 of the FCC Rules. These limits are designed to provide reasonable protection against harmful interference in a residential installation. This equipment generates, uses and can radiate radio frequency energy and, if not installed and used in accordance with the instructions, may cause harmful interference to radio communications.

However, there is no guarantee that interference will not occur in a particular installation. If this equipment does cause harmful interference to radio or television reception, which can be determined by turning the equipment off and on, the user is encouraged to try to correct the interference by one or more of the following measures:

- Reorient or relocate the receiving antenna.
- Increase the separation between the equipment and receiver.
- Connect the equipment into an outlet on a circuit different from that to which the receiver is needed.
- Consult the dealer or an experienced radio/TV technician for help.

4.2.2 Equipment safety standard compliance

The ONT equipment complies with the requirements of UL60950-1, Outdoor ONTs to “Communication Service Equipment” (CSE) and Indoor ONTs to Information Technology Equipment (ITE).

4.2.3 Environmental standards compliance

The ONT equipment complies with the following standards:

- GR-63-CORE (NEBS): requirements related to operating, storage, humidity, altitude, earthquake, office vibration, transportation and handling, fire resistance and spread, airborne contaminants, illumination, and acoustic noise
- GR-487-CORE: requirements related to rain, chemical, sand, and dust
- GR-487 R3-82: requirements related to condensation
- GR-3108: Requirements for Network Equipment in the Outside Plant (OSP)
- TP76200: Common Systems Equipment Interconnections Standards

4.2.4 Laser product standards compliance

The ONT equipment complies with 21 CFR 1040.10 and CFR 1040.11, except for deviations pursuant to Laser Notice No. 50, dated June 24, 2007” or to 21 CFR 1040.10 U.S. Center for Devices and Radiological Health (CDRH) of the Food and Drug Administration (FDA) Laser Notice 42 for ONTs containing Class 1 Laser modules certified by original manufactures.

Per CDRH 21 CFR 10.40.10 (h) (1) (iv) distributors of Class 1 laser products, such as Nokia ONTs shall leave the following Laser Safety cautions with the end user.

- a) “Class 1 Laser Product”
- b) “Caution – Use of controls or adjustments or performance of procedures other than those specified herein may result in hazardous radiation exposure.”

Figure 9 shows a laser product label.

Figure 9 Sample laser product label showing CDRH 21 CFR compliance

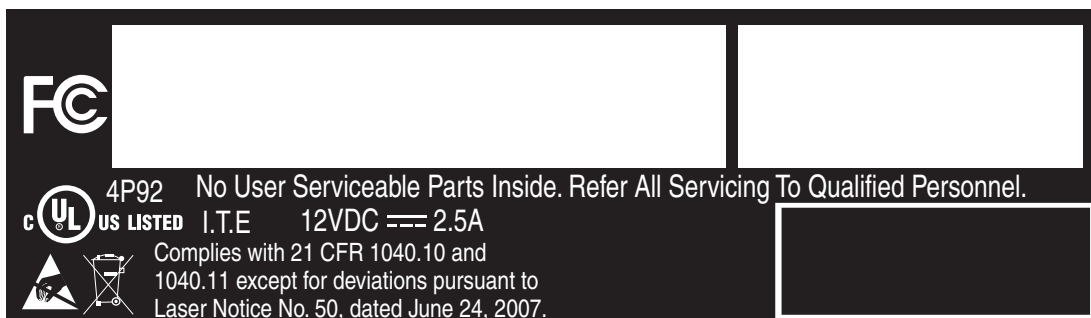

22813

4.2.5 Resistibility requirements compliance

The ONT equipment complies with the requirements of ITU Recommendation K.21 for resistibility of telecommunication equipment installed in customer premises to overvoltage and overcurrents.

4.3 Laser safety guidelines

Only qualified service personnel who are extremely familiar with laser radiation hazards should install or remove the fiber optic cables and units in this system.

Observe the following warnings when you perform installation, operations, and maintenance tasks on the ONT equipment.



Danger — There may be invisible laser radiation at the fiber optic cable when the cable is removed from the connector. Avoid direct exposure to beam.

Observe the following danger for a laser hazard. Eyes can be damaged when they are exposed to a laser beam. Take necessary precautions before you plug in the optical modules.



Danger — Possibility of equipment damage. Risk of eye damage by laser radiation.

Per CDRH 21 CFR 10.40.10 (h) (1) (iv) distributors of Class 1 laser products, such as Nokia ONTs shall leave the following Laser Safety cautions with the end user.

- a) "Class 1 Laser Product"
- b) "Caution – Use of controls or adjustments or performance of procedures other than those specified herein may result in hazardous radiation exposure."

4.3.1 Laser warning labels

The following figures show sample labels related to laser product, classification and warning.

Figure 10 shows a laser product label.

Figure 10 Laser product label

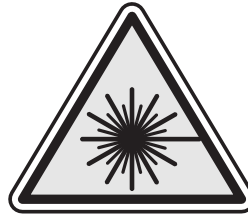

18455

Figure 11 shows a laser classification label. Laser classification labels may be provided in other languages.

Figure 11 Laser classification label

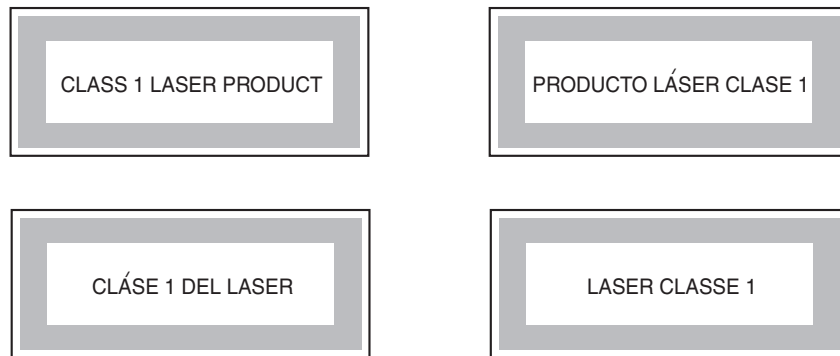

18992

Figure 12 shows a laser warning label and an explanatory label for laser products. Explanatory labels may be provided in other languages. The explanatory label provides the following information:

- a warning that calls attention to the invisible laser radiation
- an instruction against staring into the beam or viewing directly with optical instruments
- wavelength
- normal output power
- maximum output power

Figure 12 Laser warning labels



18993

4.3.2 Laser classification

The ONT is classified as a Class 1 laser product based on its transmit optical output.

For Class 1 laser products, lasers are safe under reasonably foreseeable conditions of operation, including the use of optical instruments for intrabeam viewing.

Figure 13 shows a sample laser product safety label on the ONT equipment.

Figure 13 Sample laser product safety label on the ONT equipment



18532

4.3.3 Transmit optical output

The maximum transmit optical output of an ONT is +5 dBm.

4.3.4 Normal laser operation

In normal operation, fiber cable laser radiation is always off until it receives signal from the line terminal card.

Operating personnel must observe the instructions on the laser explanatory label before plugging in the optical module.



Danger — Risk of eye damage by laser radiation.

4.3.5 Location class

Use cable supports and guides to protect the receptacles from strain.

4.4 Electrical safety guidelines

This section provides the electrical safety guidelines for the ONT equipment.



Note — The ONTs comply with the U.S. National Electrical Code. However, local electrical authorities have jurisdiction when there are differences between the local and U.S. standards.

4.4.1 Power supplies

The use of any non-Nokia approved power supplies or power adapters is not supported or endorsed by Nokia. Such use will void any warranty or support contract with Nokia. Such use greatly increases the danger of damage to equipment or property.

4.4.2 Cabling

The following are the guidelines regarding cables used for the ONT equipment:

- Use only cables approved by the relevant national electrical code.
- Use cables suitable for outdoor use for outdoor installation of ONTs.
- The ONTs have been evaluated for use with external POTS wiring without primary protection that may not exceed 140 ft (43 m) in reach. However, the power cable must not exceed 100 ft (31 m).

4.4.3 Protective earth

Earthing and bonding of the ONTs must comply with the requirements of NEC article 250 or local electrical codes.

4.5 ESD safety guidelines

The ONT equipment is sensitive to ESD. Operations personnel must observe the following ESD instructions when they handle the ONT equipment.



Caution — This equipment is ESD sensitive. Proper ESD protections should be used when entering the TELCO Access portion of the ONT.

During installation and maintenance, service personnel must wear wrist straps to prevent damage caused by ESD.

Nokia recommends that you prepare the site before you install the ONT equipment. In addition, you must control relative humidity, use static dissipating material for furniture or flooring, and restrict the use of air conditioning.

4.6 Environmental requirements

See the ONT technical specification documentation for temperature ranges for ONTs.

During operation in the supported temperature range, condensation inside the ONT caused by humidity is not an issue. To avoid condensation caused by rapid changes in temperature and humidity, Nokia recommends:

- The door of the ONT not be opened until temperature inside and outside the enclosure has stabilized.
- If the door of the ONT must be opened after a rapid change in temperature or humidity, use a dry cloth to wipe down the metal interior to prevent the risk of condensation.
- When high humidity is present, installation of a cover or tent over the ONT helps prevent condensation when the door is opened.

5 XS-240W-A and XS-250WX-A unit data sheet

- [5.1 XS-240W-A and XS-250WX-A part numbers and identification](#)
- [5.2 XS-240W-A and XS-250WX-A general description](#)
- [5.3 XS-240W-A and XS-250WX-A software and installation feature support](#)
- [5.4 XS-240W-A and XS-250WX-A interfaces and interface capacity](#)
- [5.5 XS-240W-A and XS-250WX-A LEDs](#)
- [5.6 XS-240W-A and XS-250WX-A detailed specifications](#)
- [5.7 XS-240W-A and XS-250WX-A GEM ports and T-CONTs](#)
- [5.8 XS-240W-A and XS-250WX-A functional blocks](#)
- [5.9 XS-240W-A and XS-250WX-A standards compliance](#)
- [5.10 XS-240W-A and XS-250WX-A special considerations](#)

5.1 XS-240W-A and XS-250WX-A part numbers and identification

Table 3 provides part numbers and identification information for the XS-240W-A indoor ONT.

Table 3 Identification of XS-240W-A indoor ONTs

Ordering kit part number ⁽¹⁾	Provisioning number	Description	CLEI	CPR	ECI/ Bar code
3FE 48631 AA ONT only North American Region (NAR)	3FE 48631 AA	XGSPON HGU with 2 POTS ports, 4 10/100/1000 Base-T Ethernet interfaces, and dual band 802.11n 3x3 and 802.11ac 4x4 WiFi radio with on/off switch. This ONT also has 2 USB 3.0 ports.	—	—	—

(1 of 2)

Ordering kit part number ⁽¹⁾	Provisioning number	Description	CLEI	CPR	ECI/ Bar code
3FE 48631 AC ONT only Europe, the Middle East, and Africa region (EMEA)	3FE 48631 AC	XGSPON HGU with 2 POTS ports, 4 10/100/1000 Base-T Ethernet interfaces, and dual band 802.11n 3x3 and 802.11ac 4x4 WiFi radio with on/off switch. This ONT also has 2 USB 3.0 ports.	—	—	—
3FE 48626 AA	3FE 48631 AA	XGSPON HGU with 2 POTS ports, 4 10/100/1000 Base-T Ethernet interfaces, and dual band 802.11n 3x3 and 802.11ac 4x4 WiFi radio with on/off switch. This ONT also has 2 USB 3.0 ports. Includes a 3-pin US power adapter. Also includes the power supply described in Table 5 and the wall mounting bracket (3FE 46917 AA) shown in Figure 14.	—	—	—
3FE 48626 BA	3FE 48631 AC	XGSPON HGU with 2 POTS ports, 4 10/100/1000 Base-T Ethernet interfaces, and dual band 802.11n 3x3 and 802.11ac 4x4 WiFi radio with on/off switch. This ONT also has 2 USB 3.0 ports. Includes a 3-pin EU (European) power adapter. Also includes the power supply described in Table 5 and the wall mounting bracket (3FE 46917 AA) shown in Figure 14.	—	—	—
3FE 48626 CA	3FE 48631 AC	XGSPON HGU with 2 POTS ports, 4 10/100/1000 Base-T Ethernet interfaces, and dual band 802.11n 3x3 and 802.11ac 4x4 WiFi radio with on/off switch. This ONT also has 2 USB 3.0 ports. Includes a 3-pin UK (British) power adapter. Also includes the power supply described in Table 5 and the wall mounting bracket (3FE 46917 AA) shown in Figure 14.	—	—	—

(2 of 2)

Notes

⁽¹⁾ These kits will be available in a future release.

Table 4 provides part numbers and identification information for the XS-250WX-A indoor ONT.

Table 4 Identification of XS-250WX-A indoor ONTs

Ordering kit part number ⁽¹⁾	Provisioning number	Description	CLEI	CPR	ECI/ Bar code
3FE 48307 AA ONT only North American Region (NAR)	3FE 48307 AA	XGSPON HGU with 2 POTS ports, 4 10/100/1000 Base-T Ethernet interfaces, 1 XGE UNI port, and dual band 802.11n 3x3 and 802.11ac 4x4 WiFi radio with on/off switch. This ONT also has 2 USB 3.0 ports.	—	—	—

(1 of 2)

Ordering kit part number ⁽¹⁾	Provisioning number	Description	CLEI	CPR	ECI/ Bar code
3FE 48307 AC ONT only Europe, the Middle East, and Africa region (EMEA)	3FE 48307 AC	XGSPON HGU with 2 POTS ports, 4 10/100/1000 Base-T Ethernet interfaces, 1 XGE UNI port, and dual band 802.11n 3x3 and 802.11ac 4x4 WiFi radio with on/off switch. This ONT also has 2 USB 3.0 ports.	—	—	—
3FE 48439 AA	3FE 48307 AA	XGSPON HGU with 2 POTS ports, 4 10/100/1000 Base-T Ethernet interfaces, 1 XGE UNI port, and dual band 802.11n 3x3 and 802.11ac 4x4 WiFi radio with on/off switch. This ONT also has 2 USB 3.0 ports. Includes a 3-pin US power adapter. Also includes the power supply described in Table 5.	—	—	—
3FE 48439 BA	3FE 48307 AC	XGSPON HGU with 2 POTS ports, 4 10/100/1000 Base-T Ethernet interfaces, 1 XGE UNI port, and dual band 802.11n 3x3 and 802.11ac 4x4 WiFi radio with on/off switch. This ONT also has 2 USB 3.0 ports. Includes a 3-pin EU (European) power adapter. Also includes the power supply described in Table 5.	—	—	—
3FE 48439 CA	3FE 48307 AC	XGSPON HGU with 2 POTS ports, 4 10/100/1000 Base-T Ethernet interfaces, 1 XGE UNI port, and dual band 802.11n 3x3 and 802.11ac 4x4 WiFi radio with on/off switch. This ONT also has 2 USB 3.0 ports. Includes a 3-pin UK (British) power adapter. Also includes the power supply described in Table 5.	—	—	—

(2 of 2)

Notes

(1) These kits will be available in Release 5.7.01.

Table 5 provides power supply ordering information about the XS-240W-A and XS-250WX-A ONT. For more information on power supplies, see the *7368 ISAM ONT Power Supply and UPS Guide*.

Table 5 XS-240W-A and XS-250WX-A power supply

Power/UPS model	Power UPS and cabling part number information	Customer category or country compliance tested for ⁽¹⁾	Notes
Delta power adapter, ADP-66CR BC (AC power cable not included)	Part number: 1AF29813 AA AC cable variants: <ul style="list-style-type: none"> 1AB076760010 (UK, Ireland, Middle East) 1AB076760071 (Europe) 1AB076760009 (Australia, New Zealand, and China) 1AB076760072 (UK, South Africa, and Middle East) 1AB076760073 (ANSI) 	ANSI municipality United States, Canada Common European Union countries	AC/DC 12V, 66W, 5.5A power, 6-pin Molex DC connector

Note

⁽¹⁾ The list of detailed tests (for example, GR-1089i3 (ESD, EFT, RDE, CDE, RDI, and CDI), GR-1089i4 (LightningAC) and marks (for example, FCC Class B, UL, CE Mark Class B, and K.21) are available from your Nokia technical support representative.

Table 6 provides a summary of the similarities and differences between the XS-240W-A and the XS-250WX-A ONTs and their variants.

Table 6 XS-240W-A and XS-250WX-A comparison

Feature	XS-240W-A	XS-250WX-A
PON uplink	XGSPON	XGSPON
10G UNI port	N/A	1 x 10G UNI port
Optics	Integrated XGSPON optics on board	Integrated XGSPON optics on board
LEDs	No 10G LED	All LEDs
ANSI (NAR) variant	<ul style="list-style-type: none"> ETL/FCC with DFS / WiFi Alliance 	<ul style="list-style-type: none"> ETL/FCC with DFS / WiFi Alliance
ETSI (EMEA) variant	<ul style="list-style-type: none"> EC/WiFi Alliance 	<ul style="list-style-type: none"> EC/WiFi Alliance

5.2 XS-240W-A and XS-250WX-A general description

XS-240W-A and XS-250WX-A ONTs are designed to cater to business and residential customer requirements. These ONTs offer data and video services to the subscriber.

XS-240W-A and XS-250WX-A indoor ONTs provide the subscriber interface for the network by terminating the PON interface and converting it to user interfaces that directly connect to subscriber devices. The ONT is compatible with all existing subscriber equipment, including analog phones with both tone and rotary dial capabilities, cordless phones, modems, fax machines, and caller ID boxes (Type I, Type II, and Type III).

XS-240W-A and XS-250WX-A ONTs feature an XGSPON link. The XS-250WX-A also provides one 10GE UNI port. Both ONTs provide two POTS ports and four Ethernet interfaces.

The ONTs also feature a UPS power supply connection, on/off and reset buttons, and two USB 3.0 ports.

On/off buttons are included for WPS, LEDs, and WLAN.

XS-240W-A and XS-250WX-A ONTs can be placed on a flat surface, such as a desk or shelf, or in the stand provided with the ONT kit. They can also be wall mounted using the mounting bracket (3FE 46917 AA), as shown in Figure 14.

Figure 14 XS-240W-A or XS-250WX-A in wall mounting bracket

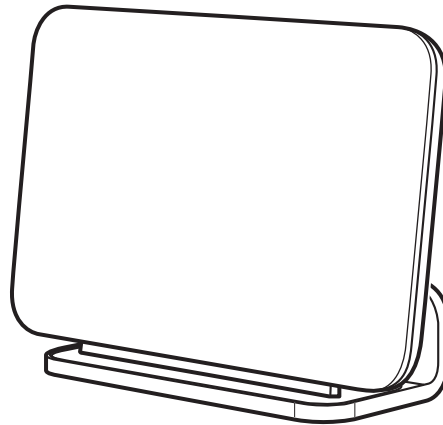

28188

Figure 15 shows the connection for the XS-240W-A ONT.

Figure 15 XS-240W-A ONT connections

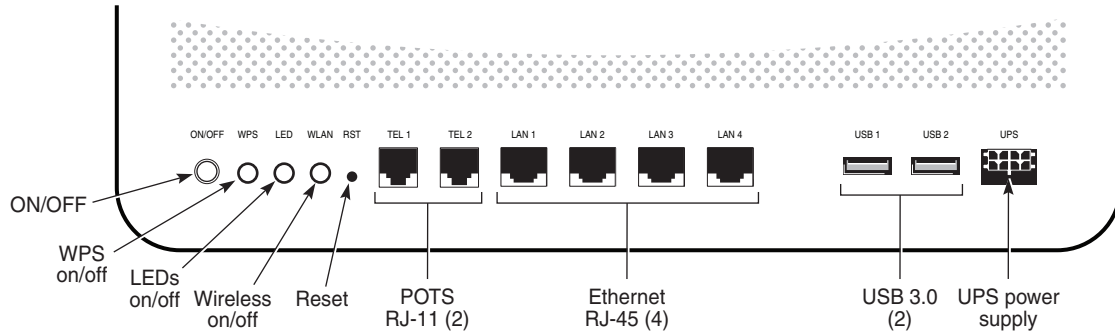

28054

Figure 16 shows the connection for the XS-250WX-A ONT.

Figure 16 XS-250WX-A ONT connections

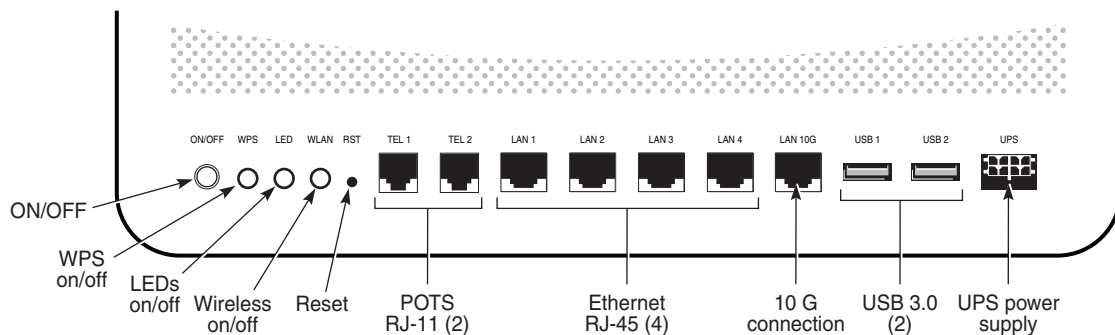

28051

XS-240W-A and XS-250WX-A indoor ONTs provide the following functions:

- 10 Gbps interface supports 100M/1G/2.5G/5G/10Gbps auto negotiation (XS-250WX-A only)
- Four RJ-45 10/100/1000 Ethernet port with auto negotiation and MDI/MDIX auto sensing
- Two POTS ports for carrier grade voice services
- Two USB 3.0 ports, accessible to all LAN devices
- Triple-Play services, including voice, video and high speed Internet access
- Traffic classification and QoS capability
- Support for fax services
- Built-in layer 2 switch; Line Rate L2 traffic
- 512M RAM and 256M Flash
- IP video distribution
- Optics that support received signal strength indication (RSSI)
- Concurrent 802.11n 3x3 MIMO in 2.4GHz and 802.11ac 4x4 MIMO in 5GHz

- WLAN on/off push button
- WPS on/off button
- 64/128 WEP encryption
- WPA, WPA-PSK/TKIP
- WPA2, WPA2-PSK/AES
- VLAN tagging/detagging and marking/remarking of IEEE 802.1p per Ethernet port.
- Dying gasp support
- SIP voice support
- Multiple voice Code
- DTMF dialing
- Echo cancellation (G.168)
- Fax mode configuration (T.30/T.38)
- Caller ID, call waiting, call hold, 3-way calling, call transfer, message waiting
- Forward Error Correction (FEC)
- Frame Check Sequence (FCS) error counter
- support for multiple SSIDs (private and public instances); contact your Nokia representative for further details.
- Routed mode per LAN port
- Ethernet-based Point-to-Point (PPPoE)
- DHCP client/server
- DNS server/client
- DDNS
- Port forwarding
- Network Address Translation (NAT)
- Network Address Port Translation (NAPT)
- UPnP IGD2.0 support
- ALG
- DMZ
- IGMP snooping and proxy (v2/v3)
- Traffic classification and QoS capability
- OMCI, TR-069, and Web GUI management support
- Performance monitoring and alarm reporting
- Remote software image downloading and activation
- IP/MAC/URL filter
- Multi-level firewall and ACL

5.2.1 TR69 authentication using TLS and CA certificates

XS-240W-A and XS-250WX-A ONTs support TLS, as well as ACS authentication using SHA-256 pre-installed certificates.

If the URL is set to the https://... format, by default, the connection will use TLS without authentication mode. The ONT can also authenticate the ACS using a pre-installed CA certificate.

5.3 XS-240W-A and XS-250WX-A software and installation feature support

For information on installing or replacing the XS-240W-A and XS-250WX-A see:

- [Install an XS-240W-A or XS-250WX-A indoor ONT](#)
- [Replace an XS-240W-A or XS-250WX-A indoor ONT](#)

For information on the following topics, see the *7368 ISAM ONT Product Overview Guide*:

- ONT and MDU general descriptions of features and functions
- Ethernet interface specifications
- POTS interface specifications
- RSSI specifications
- Wi-Fi specifications
- ONT optical budget
- SLID entry via Ethernet port
- ONT management using an ONT interface

5.4 XS-240W-A and XS-250WX-A interfaces and interface capacity

Table 7 describes the supported interfaces and interface capacity for XS-240W-A and XS-250WX-A indoor ONTs.

Table 7 XS-240W-A and XS-250WX-A indoor ONT interface connection capacity

ONT type and model	Maximum capacity					
	POTS	10/ 100/ 1000 BASE-T	RF video (CATV)	MoCA	10G UNI port	GPON SC/APC
XS-240W-A ⁽¹⁾	2	4	—	—	—	1
XS-250WX-A ⁽¹⁾	2	4	—	—	1	1

Note

⁽¹⁾ The XS-240W-A and XS-250WX-A ONTs provide Wi-Fi service that is enabled and disabled using a Wi-Fi on/off switch.

5.4.1 XS-240W-A and XS-250WX-A connections and components

Figures 15 and 16 show the physical connections for XS-240W-A and XS-250WX-A indoor ONTs,

Table 8 describes the physical connections for XS-240W-A and XS-250WX-A indoor ONTs.

Table 8 XS-240W-A and XS-250WX-A indoor ONT physical connections

Connection ⁽¹⁾	Description
On/Off button	This button turns the ONT on or off.
WPS button	The Wi-Fi Protected Setup button enables WPS2.4G and WPS5G. This button enables and disables WLAN data encryption.
LED button	This button turns the LEDs on or off.
WLAN button	Wi-Fi service is compliant with IEEE 802.11 standards and is enabled and disabled using the WLAN button.
Reset button	Pressing the Reset button for less than 10 seconds reboots the ONT; pressing the Reset button for 10 seconds resets the ONT to the factory defaults.
POTS ports	This connection is provided through RJ-11 ports. Up to two POTS connections are supported. The POTS ports support voice services.
Ethernet ports	This connection is provided through Ethernet RJ-45 connectors. Up to four 10/100/1000 Base-T Ethernet interfaces are supported. The Ethernet ports can support both data and in-band video services on all four interfaces.
10GE port (XS-250WX-A only)	The 10GE link is provided through an APC optical connector. One 10GE connection is supported.
USB ports	This connection is provided through 2 USB 3.0 ports. The ONT supports external USB hard drives that can be made accessible to all LAN devices. The following rates apply to the USB 3.0 ports: <ul style="list-style-type: none"> • Rate current: 900mA • Maximum continuous current: 1.5A • Typical short-circuit current: 2.3A
UPS power supply	This connection supports the UPS power adapter described in Table 5.

Note

⁽¹⁾ The primary path for the earth ground for these ONTs is provided by the 12V Return signal in the power connector.

5.5 XS-240W-A and XS-250WX-A LEDs

Figure 17 shows the XS-250WX-A indoor ONT LEDs.

Figure 17 XS-250WX-A indoor ONT LEDs

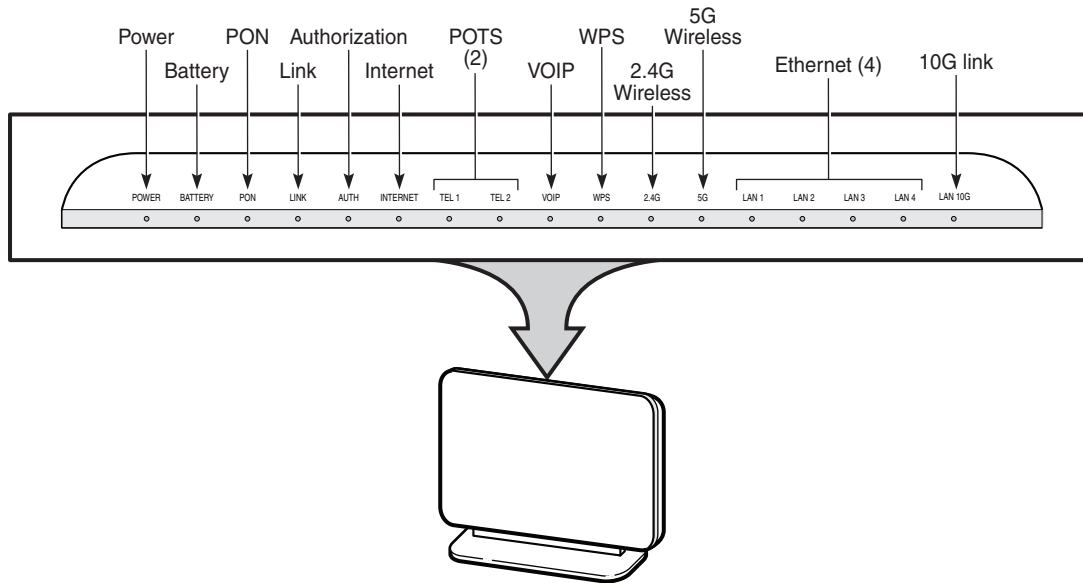

28052



Note — The XS-240W-A model does not feature a 10G UNI port and therefore does not have a LED for a 10G link.

Table 9 provides LED descriptions for XS-240W-A and XS-250WX-A indoor ONTs.

Table 9 XS-240W-A and XS-250WX-A indoor ONT LEDs

Indicator	LED color and behavior	LED behavior description
Power	Green solid Off	Power on Power off
Battery	Green solid Red Off	Device is operating on AC power Device is operating on battery power Battery alarm
PON	Green solid Green flashing Off	GPON link between ONT and OLT is operating normally Device is attempting to link GPON link is down or no link connected
Link	Green solid Off	Link between the device and the OLT is operating normally Link is down or not connected
Auth	Green solid Green flashing Off	ONT is authorized ONT is process of ranging or synchronizing on OMCI ONT is not authorized

(1 of 2)

Indicator	LED color and behavior	LED behavior description
INTERNET	Green solid Green flashing Off	HSI WAN is connected: a) the device has an IP address assigned from IPCP, DHCP, or static, and no traffic has been detected; b) the session is dropped due to idle timeout but the PON link is still present. PPPoE or DHCP connection in progress HSI WAN is not connected: a) there is no physical interface connection; b) the device is in bridged mode without an assigned IP address; c) the session has been dropped for reasons other than idle timeout.
TEL 1 to 2	Green solid Green flashing Off	Phone is off hook Phone is in 'call in' or 'talking' condition Phone is on hook
VOIP	Green solid Off	VOIP service is built up and can provide service VOIP service is not built up or out of service
WPS 2.4G and 5G	Green solid Green flashing Off	WiFi protected setup link is up (negotiation and auto-configuration successful) WiFi protected setup link activity (negotiation and auto-configuration ongoing) WiFi protected setup link down or no link connected (negotiation has not started or has failed)
WLAN 2.4G	Green solid Green flashing Off	WLAN link is enabled Traffic is passing via WLAN link WLAN link is disabled
WLAN 5G	Green solid Green flashing Off	WLAN link is enabled Traffic is passing via WLAN link WLAN link is disabled
LAN 1 to 4	Green solid Green flashing Off	Ethernet is linked LAN activity is present (in either direction) ONT power is off or Ethernet is not connected
10G (XS-250WX-A only)	Green solid Green flashing Off	10G link is operating normally 10G link activity is present (in either direction) 10G link is not connected

(2 of 2)

5.6 XS-240W-A and XS-250WX-A detailed specifications

Table 10 lists the physical specifications for XS-240W-A and XS-250WX-A indoor ONTs.

Table 10 XS-240W-A and XS-250WX-A indoor ONT physical specifications

Description	Specification
Length	11.4 in. (290.3 mm)

(1 of 2)

Description	Specification
Width	7.5 in. (190.3 mm)
Height	3.0 in. (76.6 mm)
Weight [within ± 0.5 lb (0.23 kg)]	2.7 lb (1.24 kg)

(2 of 2)

Table 11 lists the power consumption specifications for XS-240W-A and XS-250WX-A indoor ONT.

Table 11 XS-240W-A and XS-250WX-A indoor ONT power consumption specifications

Mnemonic	Maximum power (Not to exceed)	Condition	Minimum power	Condition
XS-240W-A	43 W	2 POTS off-hook, 4 10/100/1000 Base-T Ethernet, Wi-Fi operational	7.62 W	2 POTS on-hook, other interfaces/services not provisioned
XS-250WX-A	46 W		10.4 W	

Table 12 lists the environmental specifications for XS-240W-A and XS-250WX-A indoor ONT.

Table 12 XS-240W-A and XS-250WX-A indoor ONT environmental specifications

Mounting method	Temperature range and humidity	Altitude
On desk or wall mounted	Operating: 23°F to 104°F (-5°C to 40°C) ambient temperature 5% to 93% relative humidity, non-condensing at 40°C	Contact your Nokia technical support representative for more information

5.7 XS-240W-A and XS-250WX-A GEM ports and T-CONTs

Table 13 lists the maximum number of supported T-CONTs and GEM ports.

Table 13 XS-240W-A and XS-250WX-A indoor ONT capacity for GEM ports and T-CONTs

XS-240W-A and XS-250WX-A ONT	Maximum	Notes
GEM ports per indoor or outdoor ONT	124	124 are present; 122 are available, and 2 are reserved for multicast and debugging
T-CONTs per indoor or outdoor ONT	32	32 are present; 31 are available, and 1 is reserved for OMCI

5.8 XS-240W-A and XS-250WX-A functional blocks

XS-240W-A and XS-250WX-A indoor ONTs are single-residence ONTs that support Wireless (Wi-Fi) service. Wi-Fi service on these ONTs is compliant with the IEEE 802.11 standard and enabled or disabled using a WLAN button. In addition to the Wi-Fi service, these ONTs transmit Ethernet packets to four RJ-45 Ethernet ports and voice traffic to two RJ-11 POTS ports. These ONTs also feature XGPON1 fiber optic, USB, and power connectors.

Figure 18 shows the functional blocks for the XS-240W-A ONT

Figure 18 Functional blocks for XS-240W-A ONT

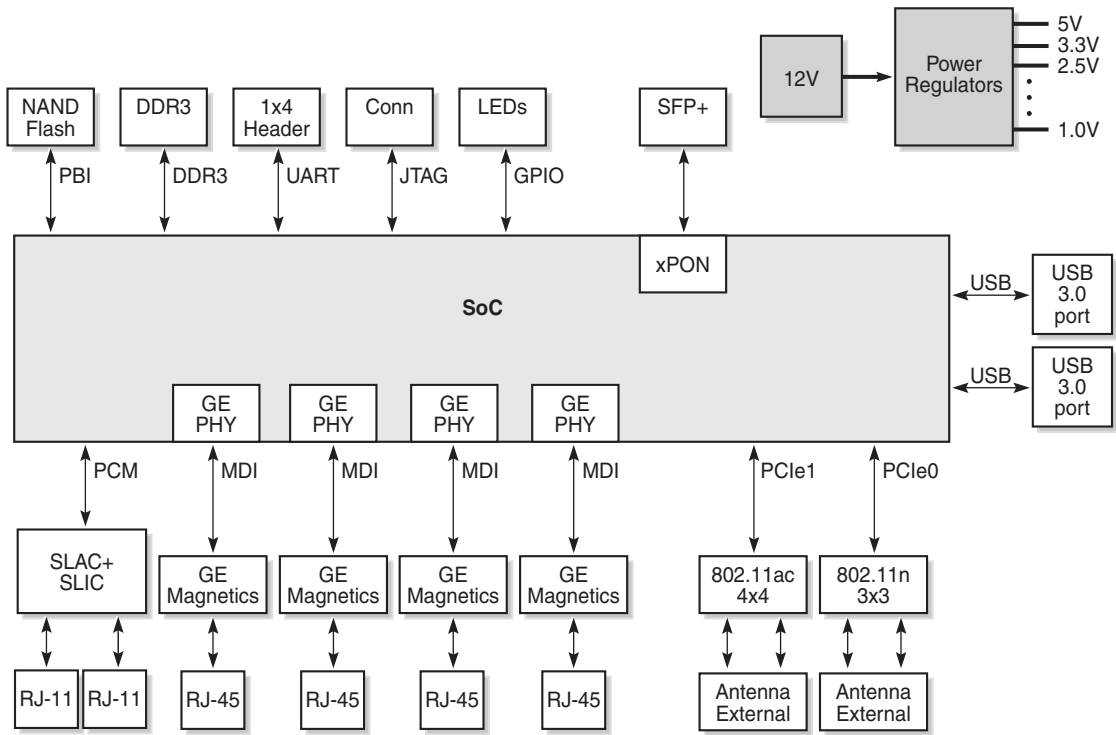

28056

Figure 19 shows the functional blocks for the XS-250WX-A ONT.

Figure 19 Functional blocks for XS-250WX-A ONT

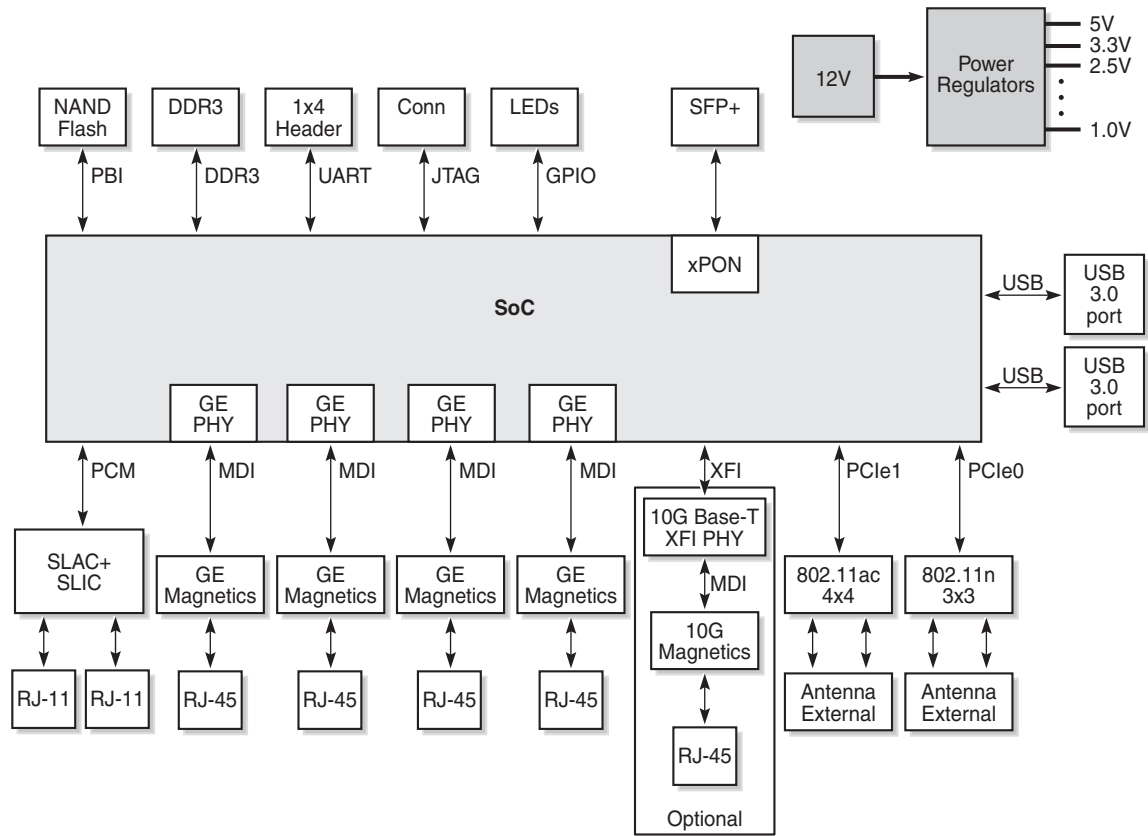

28053

ONT SoC technology serves as the main hardware block for these ONTs; see Figure 20.

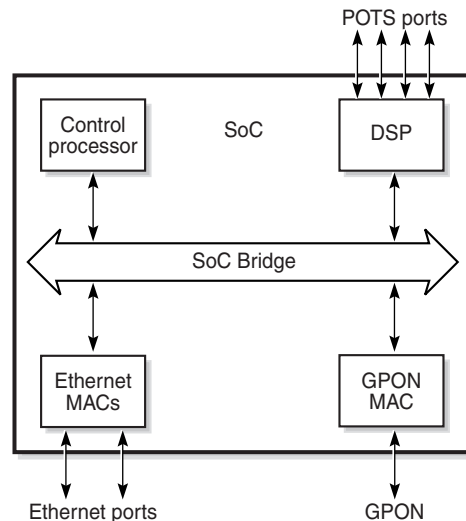
Figure 20 XS-240W-A and XS-250WX-A ONT SoC hardware block

19421

ONT SoC technology consists of five key elements:

- **GPON MAC**
The Gigabit Passive Optical Network Media Access Control (GPON MAC) element on the SoC terminates the GPON interface using an optical diplexer. This interface supports GPON as described in G.984.3 (GPON TC Layer) ITU specification.
- **Ethernet MAC**
The SoC provides up to four GE MACs.
- **DSP interface**
The Digital Signal Processor (DSP) provides voice processing for 2 POTS lines with 3-way calling. The DSP has a dedicated 64 kbyte instruction cache and shares a 32 kbyte data cache with the Control Processor. It provides up to 4 network processor cores, each at 800MHz.
- **Control Processor**
The Control Processor features an integral memory management unit that supports a dedicated 64 kbyte instruction cache and shares a single 32 kbyte data cache with the DSP. The Control Processor and DSP also include a single channel Data Management Application (DMA) controller with a 4 kbyte read ahead low-latency Dynamic Random Access Memory (DRAM) access port.
- **Switch matrix**
The Switch matrix provides an integrated data channel between the four GE MACs, the GPON MAC, the DSP, the control processor, and the other integrated elements such as flash memory, DRAM, and the local bus controller.

These ONTs can also interact with additional hardware components to support functionality not provided by the SoC technology.

5.9 XS-240W-A and XS-250WX-A standards compliance

XS-240W-A and XS-250WX-A indoor ONTs are compliant with the following standards:

- AINSI/FCC/UL
- CE marking
- China/CCC (hardware only)
- EN 300-328 for 2.4GHz bands
- EN 301-489 for EUT with WiFi
- EN 301-893 for 5GHz bands
- ETL
- ETSI/CE/CB
- G.711 support for FAX and modem connection
- G.984 support GPON interface (framing)
- G.984.2 support for Amd1, class B+
- G.984.3 support for activation and password functions
- G.984.3 support for AES with operator enable/disable on per port-ID level
- G.984.3 support for FEC in both upstream and downstream directions
- G.984.3 support for multicast using a single GEM Port-ID for all video traffic
- G984.4 and G.983.2 support for ONT management and provisioning
- G987.x support for XGPON TC layer
- IECEE CB certification
- IEEE 801.11 ac/n (Wi-Fi)
- IEEE 802.1p QoS
- IEEE 802.1q VLANs
- IEEE 802.3x flow control
- IEEE 802.3az, 802.3u, 802.3z
- ITU-T G.9807.1 support for XSPON TC layer

5.9.1 Responsible party

Table 14 lists the party in the US responsible for this ONT.

Table 14 Responsible party contact information

Legal Company name	Nokia USA Inc.
Address	2301 SUGAR BUSH RD. STE 300, RALEIGH, NC 27612
Phone, Fax	+1 919 850 6127

5.9.2 Energy-related products standby and off modes compliance

Hereby, Nokia declares that the XS-240W-A and XS-250WX-A ONTs are in compliance with the essential requirements and other relevant provisions of Directive 2009/125/EC together with Commission Regulation (EC) No 1275/2008 and Commission Regulation (EC) No 801/2013.

The XS-240W-A and XS-250WX-A ONTs qualify as equipment with high network availability (HiNA) functionality. Since the main purpose of XS-240W-A and XS-250WX-A ONTs is to provide network functionality with HiNA 7 days /24 hours, the modes Off/Standby, Power Management, and Networked Standby are inappropriate.

For information about the type and number of network ports, see [“XS-240W-A and XS-250WX-A interfaces and interface capacity”](#) in this chapter.

For information about power consumption, see [“XS-240W-A and XS-250WX-A detailed specifications”](#) in this chapter.

5.9.3 FCC statement

This equipment has been tested and found to comply with the limits for a Class B digital device, pursuant to part 15 of the FCC Rules. These limits are designed to provide reasonable protection against harmful interference in a residential installation. This equipment generates, uses and can radiate radio frequency energy and, if not installed and used in accordance with the instructions, may cause harmful interference to radio communications. However, there is no guarantee that interference will not occur in a particular installation. If this equipment does cause harmful interference to radio or television reception, which can be determined by turning the equipment off and on, the user is encouraged to try to correct the interference by one or more of the following measures:

- Reorient or relocate the receiving antenna.
- Increase the separation between the equipment and receiver.
- Connect the equipment into an outlet on a circuit different from that to which the receiver is connected.
- Consult the dealer or an experienced radio/TV technician for help.

5.9.4 FCC Radiation Exposure Statement

This device complies with FCC radiation exposure limits set forth for an uncontrolled environment and it also complies with Part 15 of the FCC RF Rules. This equipment must be installed and operated in accordance with provided instructions and the antenna(s) used for this transmitter must be installed to provide a separation distance of at least 20 cm from all persons and must not be co-located or operating in conjunction with any other antenna or transmitter. End-users and installers must be provided with antenna installation instructions and consider removing the no-collocation statement.

This device complies with Part 15 of the FCC Rules. Operation is subject to the following two conditions:

- 1 this device may not cause harmful interference, and
- 2 this device must accept any interference received, including interference that may cause undesired operation.



Caution — Any changes or modifications not expressly approved by the party responsible for compliance could void the user's authority to operate the equipment.

5.10 XS-240W-A and XS-250WX-A special considerations

XS-240W-A and XS-250WX-A are package P ONTs.

5.10.1 Wi-Fi service

XS-240W-A and XS-250WX-A indoor ONTs feature Wi-Fi service as well as voice and data services. Wi-Fi is a wireless networking technology that uses radio waves to provide wireless HSI and network connections. This ONT complies with the IEEE 802.11 standards, which the Wi-Fi Alliance defines as the basis for Wi-Fi technology.

5.10.1.1 Wi-Fi physical features

XS-240W-A and XS-250WX-A indoor ONTs have the following physical features that assist in providing Wi-Fi service:

- 7 internal antennae: 3 for 2.4G and 4 for 5G
- WLAN button for enabling and disabling Wi-Fi service
- one Wi-Fi Protected Setup (WPS) push button (for 2.4G and 5G) for adding WPS-enabled wireless devices

5.10.1.2 Wi-Fi standards and certifications

The Wi-Fi service on XS-240W-A and XS-250WX-A indoor ONTs supports the following IEEE standards and Wi-Fi Alliance certifications:

- certified for IEEE 802.11ac/b/g/n standards
- WPA support including WPA-PSK
- certified for WPA2-Personal and WPA2-Enterprise

5.10.1.3 Wi-Fi GUI features

XS-240W-A and XS-250WX-A indoor ONTs have HTML-based Wi-Fi configuration GUIs.

5.10.2 XS-240W-A and XS-250WX-A ONT considerations and limitations

Table 15 lists the considerations and limitations for Package P XS-240W-A and XS-250WX-A ONTs.

Table 15 XS-240W-A and XS-250WX-A ONT considerations and limitations

Considerations and limitations
Some voice features are configurable on a per ONT basis, including Call Waiting, Call Hold, 3-Way Calling, and Call Transfer.
The following voice features / GSIP parameters are configurable on a per-Client/ per-ONT basis (not per-Subscriber): <ul style="list-style-type: none"> • Enable Caller ID and Enable Caller Name ID • Digitmap and the associated Interdigit and Critical timers and Enter key parameters • Warmline timer is enabled per subscriber, but the warmline timer value is configured per ONT and must have a lower value than the Permanent time • Miscellaneous timers: Permanent, Timed-release, Reanswer, Error-tone, and CW-alert timers • Features / functions: Message waiting mode, WMWI refresh interval, DTMF volume level • Service Codes for the following features: CCW, Call Hold and Warmline
The following features are not supported in Release 5.6: port triggering, port mirroring, parental control (access restrictions), and policy-based forwarding (in IP routing and QoS configuration).
This device is restricted to indoor use.

6 Install an XS-240W-A or XS-250WX-A indoor ONT

6.1 Purpose

6.2 General

6.3 Prerequisites

6.4 Recommended tools

6.5 Safety information

6.6 Procedure

6.1 Purpose

This chapter provides the steps to install an XS-240W-A or XS-250WX-A indoor ONT.

6.2 General

The steps listed in this chapter describe mounting and cabling for XS-240W-A or XS-250WX-A indoor ONTs.

6.3 Prerequisites

You need the following items before beginning the installation:

- all required cables

6.4 Recommended tools

You need the following tools for the installation:

- #2 Phillips screwdriver
- 1/4 in. (6 mm) flat blade screwdriver
- wire strippers
- fiber optic splicing tools

- RJ-45 cable plug crimp tool
- voltmeter or multimeter
- optical power meter
- drill and drill bits
- paper clip

6.5 Safety information

Read the following safety information before installing the unit.



Danger 1 — Hazardous electrical voltages and currents can cause serious physical harm or death. Always use insulated tools and follow proper safety precautions when connecting or disconnecting power circuits.

Danger 2 — Make sure all sources of power are turned off and have no live voltages present on feed lines or terminals. Use a voltmeter to measure for voltage before proceeding.

Danger 3 — Always contact the local utility company before connecting the enclosure to the utilities.



Warning — This equipment is ESD sensitive. Proper ESD protections should be used when removing the fiber access cover of the indoor ONT.



Caution — Keep indoor ONTs out of direct sunlight. Prolonged exposure to direct sunlight can damage the unit.



Note 1 — Observe the local and national laws and regulations that may be applicable to this installation.

Note 2 — Observe the following:

- The indoor ONT should be installed in accordance with the applicable requirements of the NEC or CEC. Local authorities and practices take precedent when there is conflict between the local standard and the NEC or CEC.
- The indoor ONT must be installed by qualified service personnel.
- Indoor ONTs must be installed with cables that are suitably rated and listed for indoor use.
- See the detailed specifications in the [XS-240W-A and XS-250WX-A unit data sheet](#) for the temperature ranges for these ONTs.

6.6 Procedure

Use this procedure to install an XS-240W-A or XS-250WX-A indoor ONT.

1 Place the indoor ONT unit:

- a** On the flat surface, such as a desk or shelf, or in the stand provided with the ONT kit; go to step [3](#).



Note — The XS-240W-A or XS-250WX-A ONT cannot be stacked with another ONT or with other equipment. The ONT mounting requirements are:

- allow a minimum 100 mm clearance above the top cover
- allow a minimum 50 mm clearance from the side vents
- do not place any heat source directly above the top cover or below the bottom cover

- b** On a wall, go to step [2](#).
-

2 Mount the ONT on a wall using the wall mounting bracket (3FE 46917 AA) shown in Figure [21](#).

Figure 21 XS-240W-A and XS-250WX-A wall mounting bracket

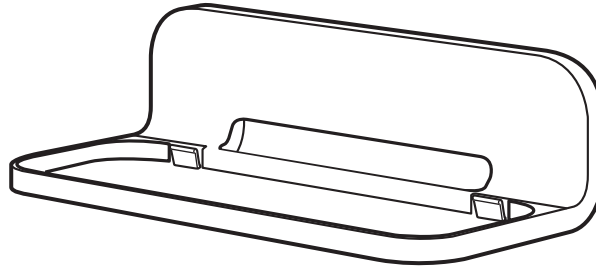

28187

Figure 22 shows the ONT mounted in the wall bracket. Be careful not to bend the cables.

Figure 22 XS-240W-A and XS-250WX-A ONT in wall mounting bracket

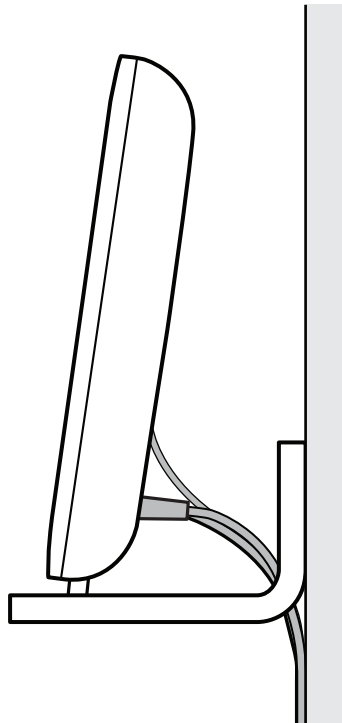

28189

3 Review the connection locations as shown in Figures 23 and 24.

Figure 23 XS-240W-A ONT connections

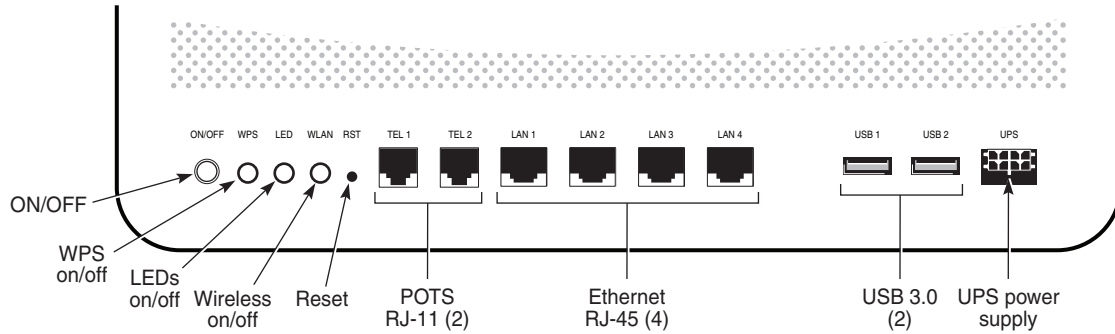

28054

Figure 24 XS-250WX-A connections

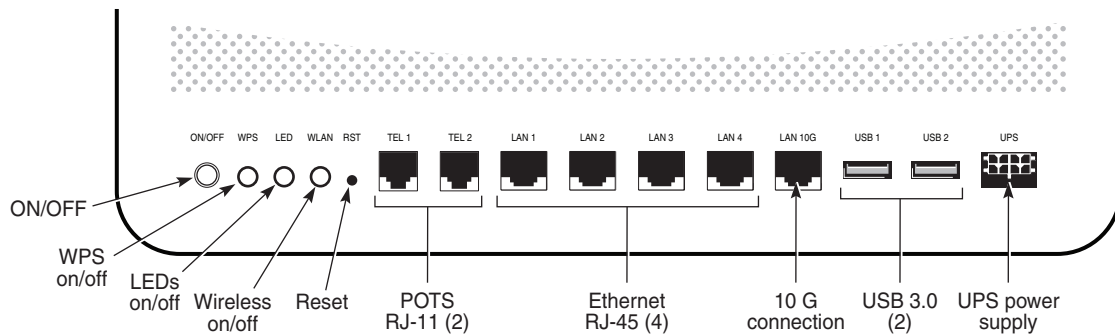

28051



Note — The 10 GE UNI port is only featured on the XS-250WX-A.

4 Connect the Ethernet cables to the RJ-45 ports; see Figure 23 or 24 for the location of the RJ-45 ports.

5 Route the POTS cables directly to the RJ-11 ports as per local practices.

The POTS port to the left is labeled TEL1 for Line 1 while the port on the right is labeled TEL2 for Line 2, as shown in Figure 23 or 24.

-
- 6 For the XS-250WX-A ONT, connect the fiber optic cable with APC adapter into the 10GE connector; see Figure 24 for the location of the 10GE connector.



Danger — Fiber cables transmit invisible laser light. To avoid eye damage or blindness, never look directly into fibers, connectors, or adapters.



Warning — Be careful to maintain a bend radius of no less than 1.5 in. (3.8 cm) when connecting the fiber optic cable. Too small of a bend radius in the cable can result in damage to the optic fiber.



Note — Fiber cable preparation varies depending on the type and size of the inside or outside plant fiber cable being spliced to the SC/APC fiber optic pigtail cable.

-
- 7 Install the power supply according to manufacturer specifications.



Note — Observe the following:

- Units must be powered by a Listed or CE approved and marked limited power source power supply with a minimum output rate of 12VDC, 3A.

-
- 8 Power up the ONT unit by using the power switch.

-
- 9 If used, enable the Wi-Fi service:

- i Locate the WLAN button on the ONT; see Figure 23 or 24 for location of the WLAN button.
- ii Press the WLAN button to change the status of the Wi-Fi service.

-
- 10 If used, enable the WPS service.

- i Locate the WPS buttons on the ONT; see Figure 23 or 24 for location of the WPS buttons for 2.4G and 5G Wi-Fi.
- ii Press the WPS buttons to change the status of the Wi-Fi Protected Service.

-
- 11 Verify the ONT LEDs, voltage status, and optical signal levels; see the *7368 Hardware and Cabling Installation Guide*.

-
- 12 Activate and test the services; see the *7368 Hardware and Cabling Installation Guide*.

-
- 13** If used, configure the SLID; see the *7368 ISAM ONT Configuration, Management, and Troubleshooting Guide*.
-
- 14** If necessary, reset the ONT.
- i** Locate the Reset button on a XS-240W-A or XS-250WX-A indoor ONT as shown in Figure [23](#) or [24](#).
 - ii** Insert the end of a straightened paper clip or other narrow object into the hole in the Reset button to reset the ONT.
-
- 15** STOP. This procedure is complete.

7 Replace an XS-240W-A or XS-250WX-A indoor ONT

7.1 Purpose

7.2 General

7.3 Prerequisites

7.4 Recommended tools

7.5 Safety information

7.6 Procedure

7.1 Purpose

This chapter provides the steps to replace XS-240W-A or XS-250WX-A indoor ONTs.

7.2 General

The steps listed in this chapter describe mounting and cabling for XS-240W-A or XS-250WX-A indoor ONTs.

7.3 Prerequisites

You need the following items before beginning the installation:

- all required cables

7.4 Recommended tools

You need the following tools for replacing the ONT:

- #2 Phillips screwdriver
- 1/4 in. (6 mm) flat blade screwdriver
- wire strippers
- fiber optic splicing tools

- RJ-45 cable plug crimp tool
- voltmeter or multimeter
- optical power meter
- drill and drill bits

7.5 Safety information

Read the following safety information before replacing the unit.



Danger 1 — Hazardous electrical voltages and currents can cause serious physical harm or death. Always use insulated tools and follow proper safety precautions when connecting or disconnecting power circuits.

Danger 2 — Make sure all sources of power are turned off and have no live voltages present on feed lines or terminals. Use a voltmeter to measure for voltage before proceeding.

Danger 3 — Always contact the local utility company before connecting the enclosure to the utilities.



Warning — This equipment is ESD sensitive. Proper ESD protections should be used when removing the fiber access cover of the indoor ONT.



Caution — Keep indoor ONTs out of direct sunlight. Prolonged exposure to direct sunlight can damage the unit.



Note 1 — Observe the local and national laws and regulations that may be applicable to this installation.

Note 2 — Observe the following:

- The indoor ONT should be installed in accordance with the applicable requirements of the NEC or CEC. Local authorities and practices take precedent when there is conflict between the local standard and the NEC or CEC.
- The indoor ONT must be installed by qualified service personnel.
- Indoor ONTs must be installed with cables that are suitably rated and listed for indoor use.
- See the detailed specifications in the [XS-240W-A and XS-250WX-A unit data sheet](#) for the ONT temperature ranges for these ONTs.

7.6 Procedure

Use this procedure to replace an XS-240W-A or XS-250WX-A indoor ONT.

1 Deactivate the ONT services at the P-OLT.

If you are using the SLID feature, this step is not required. The ONT and the services can remain in service (IS).

- i Use the RTRV-ONT command to verify the ONT status and th associated services. Record the serial number or the SLID of the ONT displayed in the command output.

Example:

```
RTRV-ONT::ONT-1-1-1-1-1;
```

- ii If the ONT is in service, place the ONT in OOS state.

Example:

```
ED-ONT::ONT-1-1-1-1-1;
```

2 If used, disable the Wi-Fi service by pressing the WLAN button; see Figure 25 for 26 for the location of the WLAN button.

Figure 25 XS-240W-A ONT connections

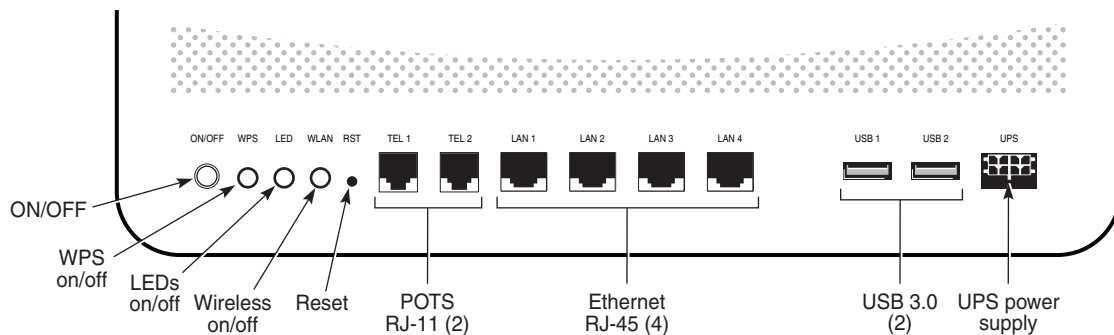

28054

Figure 26 XS-250WX-A ONT connections

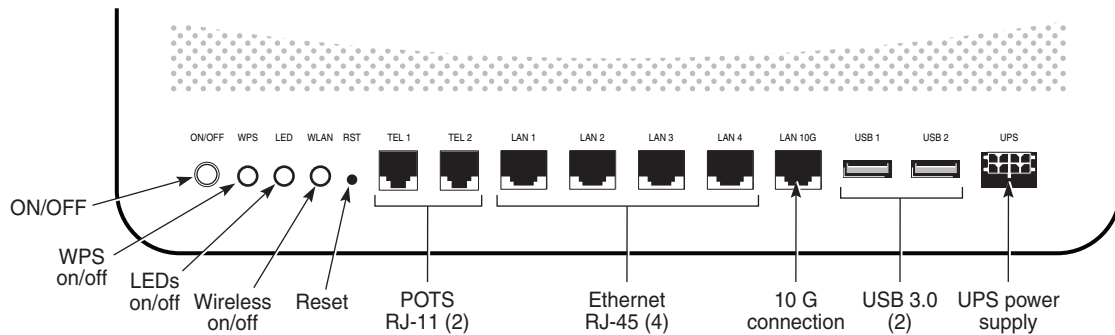

28051

- 3** Power down the unit by using the on/off power switch; see Figure 25 or 26 for the on/off switch.

Note that the 10 GE UNI port is only featured on the XS-250WX-A.

- 4** Disconnect the POTS, Ethernet, and power cables from the ONT; see Figure 25 or 26 for the connector locations on the XS-240W-A and XS-250WX-A indoor ONT.

- 5** Unplug the fiber optic cable with APC connector from the ONT; see Figure 25 or 26 for the location of the fiber optic port.



Danger — Fiber cables transmit invisible laser light. To avoid eye damage or blindness, never look directly into fibers, connectors, or adapters.

- 6** Replace the ONT with a new unit.

- 7** Connect the Ethernet cables directly to the RJ-45 ports; see Figure 25 or 26 for the location of the RJ-45 ports.

- 8** Connect the POTS cables directly to the RJ-11 ports as per local practices; see Figure 25 or 26 for the location of the RJ-11 ports.

The RJ-11 port to the left is labeled TEL1 for Line 1 while the port on the right is labeled TEL2 for Line 2.

-
- 9 If required, have approved service personnel who are trained to work with optic fiber clean the fiber optic connection. See the *7368 ISAM ONT Configuration, Management, and Troubleshooting Guide* for more information about fiber optic handling, inspection, and cleaning.



Danger — Fiber optic cables transmit invisible laser light. To avoid eye damage or blindness, never look directly into fibers, connectors, or adapters.

-
- 10 For the XS-250WX-A ONT, connect the fiber optic cable with APC adapter into the APC connector. Figure 26 shows the location of the fiber optic connector.



Danger — Fiber cables transmit invisible laser light. To avoid eye damage or blindness, never look directly into fibers, connectors, or adapters.



Warning — Be careful to maintain a bend radius of no less than 1.5 in. (3.8 cm) when connecting the fiber optic cable. Too small of a bend radius in the cable can result in damage to the optic fiber.



Note — Fiber cable preparation varies depending on the type and size of the inside or outside plant fiber cable being spliced to the SC/APC fiber optic pigtail cable.

-
- 11 Install the power supply according to manufacturer specifications.



Note — Observe the following:

- Units must be powered by a Listed or CE approved and marked limited power source power supply with a minimum output rate of 12VDC, 3A.

-
- 12 Power up the unit by using the power on/off switch.

-
- 13 If used, enable the Wi-Fi service by pressing the WLAN button; see Figure 25 or 26 for the location of the WLAN button.

-
- 14 If used, enable the WPS service.

- i Locate the WPS buttons on the ONT; see Figure 25 or 26 for location of the WPS buttons for 2.4G and 5G Wi-Fi.
- ii Press the WPS buttons to change the status of the Wi-Fi Protected Service.

-
- 15** If used, configure the SLID; see the *7368 ISAM ONT Configuration, Management, and Troubleshooting Guide* for more information.



Note — A new SLID or the old SLID may be used with the replacement ONT. If a new SLID is used, the new SLID must also be programmed at the P-OLT using TL1 or a network manager. If the old SLID is used, no changes need to be made at the P-OLT; see the operations and maintenance documentation for the OLT for more details.

-
- 16** Verify the ONT LEDs, voltage status, and optical signal levels; see the *7368 Hardware and Cabling Installation Guide*.

-
- 17** Activate and test the services; see the *7368 Hardware and Cabling Installation Guide*.

-
- 18** If necessary, reset the ONT.

- i Locate the Reset button on a XS-240W-A or XS-250WX-A indoor ONT as shown in Figure 25 or 26.
- ii Insert the end of a straightened paper clip or other narrow object into the hole in the Reset button to reset the ONT.

-
- 19** STOP. This procedure is complete.

8 Configure an XS-240W-A or XS-250WX-A indoor ONT

8.1 General

8.2 HGU mode GUI configuration

8.1 General

Please refer to the configuration information provided with your OLT for the software configuration procedure for an XS-240W-A or XS-250WX-A ONT.

For HTTP configuration procedures, please refer to the *7368 ISAM ONT Configuration, Management, and Troubleshooting Guide*.

8.2 HGU mode GUI configuration

Use the procedures below to use the web-based GUI for the XS-240W-A or XS-250WX-A in HGU mode. This mode is preset at delivery.

A home gateway unit (HGU) is a home networking device, used as a gateway to connect devices in the home through fiber to the Internet. An HGU provides a variety of features for the home network including routing and firewall capability. By using the HGU, users can connect all smart equipment in their home, including personal computers, set-top boxes, mobile phones, and other consumer electronics devices, to the Internet.

8.2.1 Login

Use the procedure below to login to the web-based GUI for the XS-240W-A or XS-250WX-A.

Procedure 6 Login to web-based GUI

-
- 1 Open a web browser and enter the IP address of the ONT in the address bar.

The login window appears.

The default gateway IP address is `http://192.168.1.254`. You can connect to this IP address using your web browser after connecting your PC to one of Ethernet ports of the ONT. The static IP address of your PC must be in the same 192.168.1.x subnet as the ONT.

-
- 2 Enter your username and password in the Log in window, as shown in Figure 27.

The default user name is AdminGPON. The default password for OPID ALCL is ALC#FGU.

Figure 27 Web login window

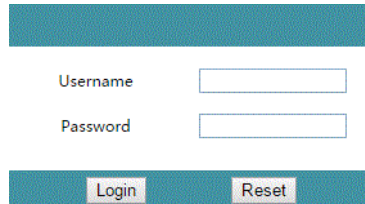

The screenshot shows a web login interface. At the top is a teal header bar. Below it are two input fields: 'Username' and 'Password'. At the bottom are two buttons: 'Login' and 'Reset'.



Caution — Pressing the Reset button for less than 10 seconds reboots the ONT; pressing the Reset button for 10 seconds resets the ONT to the factory defaults.



Note — If you forget the current username and password, press the reset button for 5 s and the default values for the username and password will be recovered at startup.

-
- 3 Click Login. The Device Information screen appears.



Note — To help protect the security of your Internet connection, the application displays a pop-up reminder to change both the Wi-Fi password and the ONT password.

To increase password security, use a minimum of 10 characters, consisting of a mix of numbers and upper and lower case letters.

-
- 4 STOP. This procedure is complete.
-

8.2.2 Device and connection status

XS-240W-A and XS-250WX-A ONTs support the retrieval of a variety of device and connection information, including:

- device information
- LAN status
- WAN status

- WAN status IPv6
- Home networking information
- optics module status
- statistics
- voice information

Procedure 7 Device information retrieval

- 1 Select Status > Device Information from the top-level menu in the 10G PON Gateway window, as shown in Figure 28.

Figure 28 Device Information window

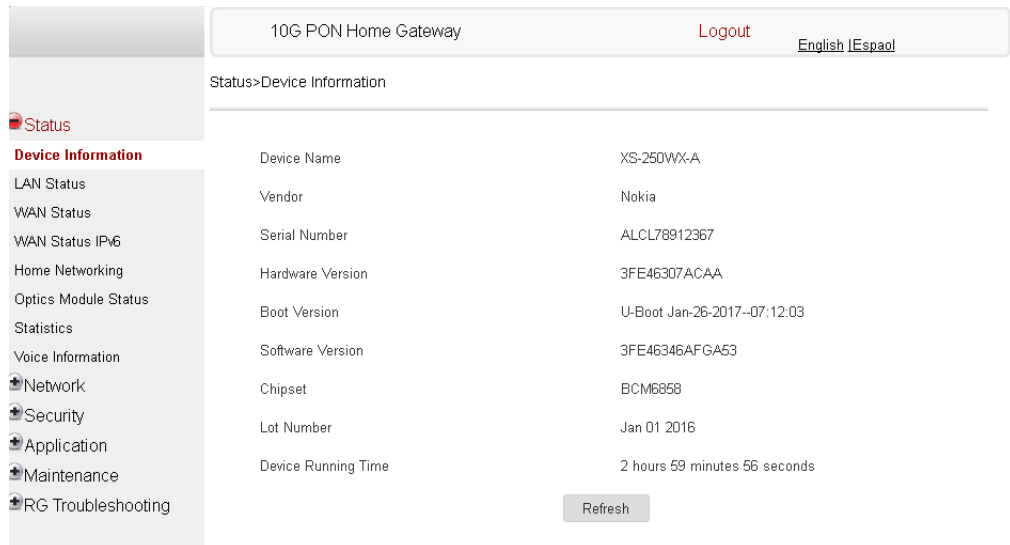

Table 16 describes the fields in the Device Information window.

Table 16 Device Information parameters

Field	Description
Device Name	Name on the ONT
Vendor	Name of the vendor
Serial Number	Serial number of the ONT
Hardware version	Hardware version of the ONT
Boot version	Boot version of the ONT
Software version	Software version of the ONT

(1 of 2)

Field	Description
Chipset	Chipset of the ONT
Lot Number	Production date of the ONT
Device Running Time	Amount of time the device has run since last reset in hours, minutes, and seconds

(2 of 2)

2 Click Refresh to update the displayed information.

3 STOP. This procedure is complete.

Procedure 8 LAN status retrieval

- 1 Select Status > LAN Status from the top-level menu in the 10G PON Gateway window, as shown in Figure 29.

Figure 29 LAN status window

Information	LAN1	LAN2	LAN3	LAN4	LAN5(10G)
Status	Up	Up	Down	Up	Down
Duplex Mode	Full	Full	Auto	Full	Full
Max Bit Rate	1000	1000	Auto	1000	10
Errors Received	0	0	0	0	0
Errors Sent	0	0	0	0	0
Packets Received	13819	0	0	0	0
Packets Sent	11369	333	0	334	0

Table 17 describes the fields in the LAN status window.

Table 17 LAN status parameters

Field	Description
Wireless Information	

(1 of 2)

Field	Description
Wireless Status	Indicates whether the wireless is on or off
Wireless Channel	Wireless channel number
SSID Name	Name of each SSID
Wireless Encryption Status	Encryption type used on the wireless connection
Wireless Rx Packets	Number of packets received on the wireless connection
Wireless Tx Packets	Number of packets transmitted on the wireless connection
Wireless Rx Bytes	Number of bytes received on the wireless connection
Wireless Tx Bytes	Number of bytes transmitted on the wireless connection
Power Transmission (mW)	Power of the wireless transmission, in mW
Ethernet Information	
Ethernet Status	Indicates whether the Ethernet connection is on or off
Ethernet IP Address	IP address of the Ethernet connection
Ethernet Subnet Mask	Subnet Mask of the Ethernet connection
Ethernet MAC Address	MAC address of the Ethernet connection
Ethernet Rx Packets	Number of packets received on the Ethernet connection
Ethernet Tx Packets	Number of packets transmitted on the Ethernet connection
Ethernet Rx Bytes	Number of bytes received on the Ethernet connection
Ethernet Tx Bytes	Number of bytes transmitted on the Ethernet connection
LAN 1 to 4 and LAN 5 (10G) information	This panel displays the following information for each LAN: <ul style="list-style-type: none"> • status (up or down) • duplex mode (full or auto) • max bit rate • errors received • errors sent • packets received • packets sent • bytes received • bytes sent

(2 of 2)

2 Click Refresh to update the displayed information.

3 STOP. This procedure is complete.

Procedure 9 WAN status retrieval

- 1 Select Status > WAN Status from the top-level menu in the 10G PON Gateway window, as shown in Figure 30.

Figure 30 WAN status window

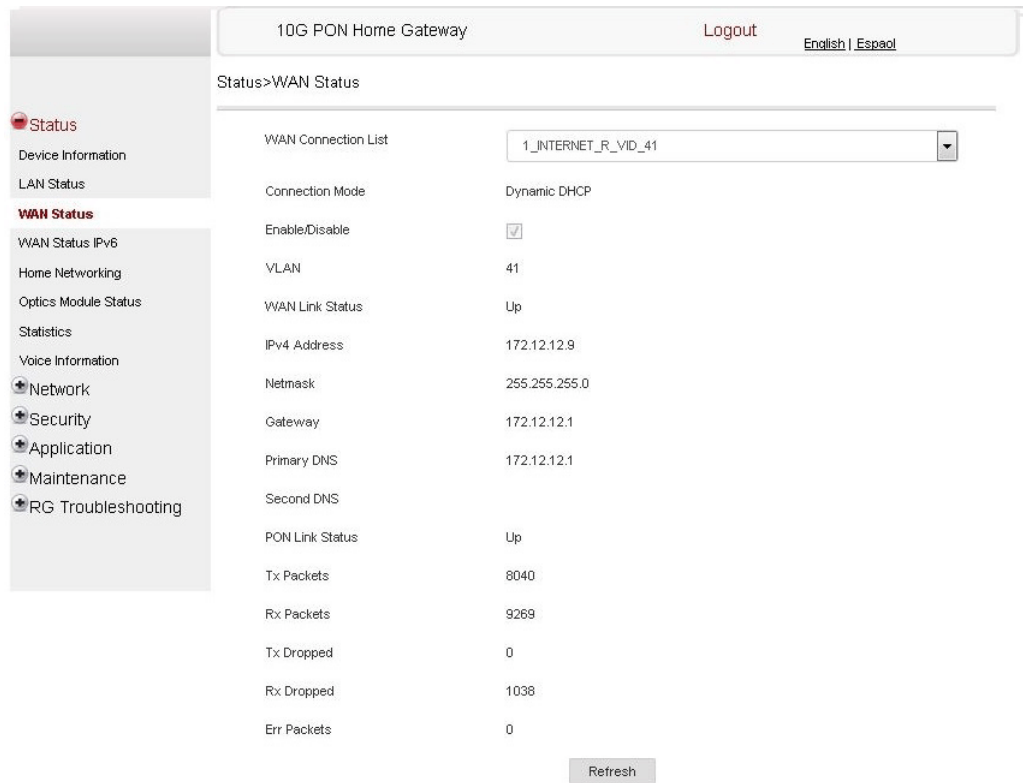

Table 18 describes the fields in the WAN status window.

Table 18 WAN status parameters

Field	Description
WAN connection list	Drop-down menu listing all WAN connections. The connection shown is the connection for which WAN status will be shown.
Connection Mode	Connection mode of the WAN connection
Enable/Disable	Select this checkbox to enable the WAN connection
VLAN	VLAN ID
WAN Link Status	Whether the WAN link is up or down

(1 of 2)

Field	Description
IPv4 Address	IPv4 address
Netmask	Netmask
Gateway	IPv4 gateway address
Primary DNS	Primary Domain Name Server
Second DNS	Secondary Domain Name Server
PON Link Status	Whether the PON link is up or down
Tx Packets	Number of packets transmitted on the WAN connection
Rx Packets	Number of packets received on the WAN connection
Tx Dropped	Number of packets dropped on the transmit WAN connection
Rx Dropped	Number of packets dropped on the receive WAN connection
Err Packets	Number of errored packets on the WAN connection

(2 of 2)

2 Click Refresh to update the displayed information.

3 STOP. This procedure is complete.

Procedure 10 WAN status IPv6 retrieval

- 1 Select Status > WAN Status IPv6 from the top-level menu in the 10G PON Gateway window, as shown in Figure 31.

Figure 31 WAN status IPv6 window

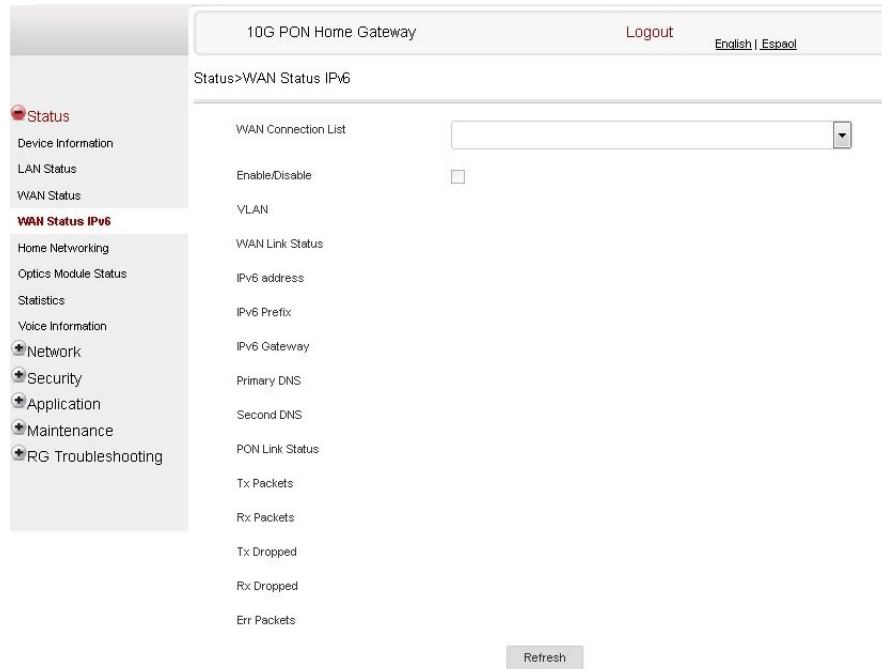

Table 19 describes the fields in the WAN status IPv6 window.

Table 19 WAN status IPv6 parameters

Field	Description
WAN connection list	Drop-down menu listing all WAN connections. The connection shown is the connection for which WAN status will be shown.
Enable/Disable	Select this checkbox to enable the WAN connection
VLAN	VLAN ID
WAN Link Status	Whether the WAN link is up or down
IPv6 Address	IPv6 address that identifies the device and its location
IPv6 Prefix	IPv6 Prefix
IPv6 Gateway	IPv6 Gateway address
Primary DNS	Primary Domain Name Server

(1 of 2)

Field	Description
Second DNS	Secondary Domain Name Server
PON Link Status	Whether the PON link is up or down
Tx Packets	Number of packets transmitted on the WAN connection
Rx Packets	Number of packets received on the WAN connection
Tx Dropped	Number of packets dropped on the transmit WAN connection
Rx Dropped	Number of packets dropped on the receive WAN connection
Err Packets	Number of errored packets on the WAN connection

(2 of 2)

2 Click Refresh to update the displayed information.

3 STOP. This procedure is complete.

Procedure 11 Home networking information retrieval

- 1 Select Status > Home Networking from the top-level menu in the 10G PON Gateway window, as shown in Figure 32.

Figure 32 Home networking information window

The screenshot shows the '10G PON Home Gateway' web interface. The breadcrumb path is 'Status > Home Networking'. The sidebar menu includes: Status, Device Information, LAN Status, WAN Status, WAN Status IPv6, **Home Networking**, Optics Module Status, Statistics, Voice Information, Network, Security, Application, Maintenance, and RG Troubleshooting. The main content area is divided into three sections:

- Local Interface:** A table with columns 'Connection Type', 'Connected Devices', and 'Setting'. It lists Ethernet (1 device), Wireless (2.4GHz) (0 devices), and Wireless (5GHz) (0 devices).
- Wireless Settings (2.4GHz):** A table with columns 'Network Name' and 'Access Point'. It lists four networks: ALHN-1983, ALHN-1983-2, ALHN-1983-3, and ALHN-1983-4, each with a corresponding MAC address.
- Wireless Settings (5GHz):** A table with columns 'Network Name' and 'Access Point'. It lists four networks: ALHN-1983-5, ALHN-1983-6, ALHN-1983-7, and ALHN-1983-8, each with a corresponding MAC address.
- Local Devices:** A table with columns 'Status', 'Connection Type', 'Device Name', 'IPv4 Address', 'Hardware Address', 'IP Address Allocation', and 'Delete'. It shows one active device connected via Ethernet with IP 192.168.1.64 and hardware address dc:4a:3e:8f:90:14.

A 'Refresh' button is located at the bottom of the Local Devices section.

Table 20 describes the fields in the Home networking window.

Table 20 Home networking parameters

Field	Description
Local Interface	
Ethernet	Table displays the number of Ethernet connections and their settings
Wireless	Table displays the number of wireless connections and their settings
Wireless Settings	
Network Name	Name of the wireless network
Access Point	Address of the wireless access point
Local Devices	

(1 of 2)

Field	Description
Table entry	Each entry indicates the status (active or inactive), connection type, device name, IP address, hardware address, and IPv4 address allocation of each connected local device.

(2 of 2)

- 2 Click Delete to delete a particular local device connection.
- 3 Click Refresh to update the displayed information.
- 4 STOP. This procedure is complete.

Procedure 12 Optics module status retrieval

- 1 Select Status > Optics Module Status from the top-level menu in the 10G PON Gateway window, as shown in Figure 33.

Figure 33 Optics module status window

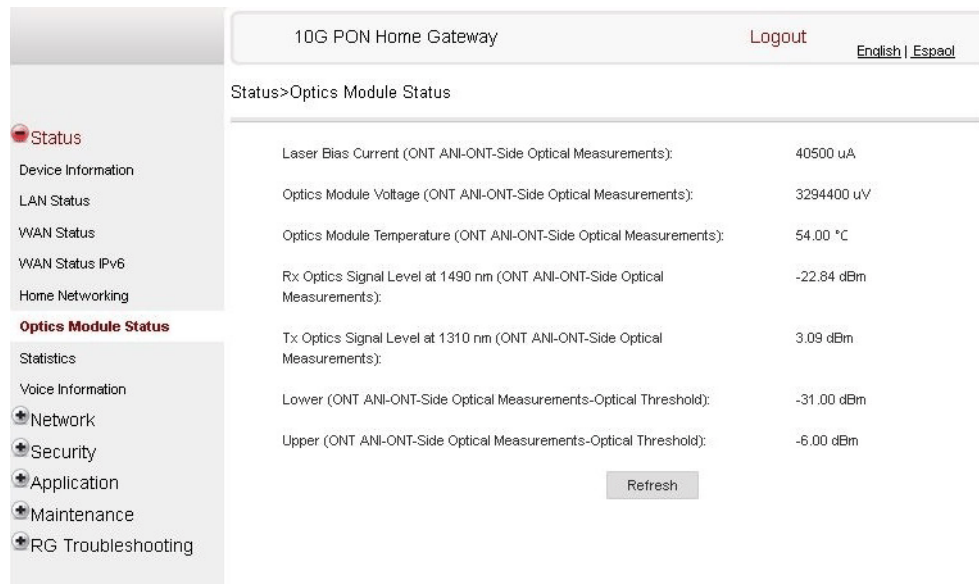

Table 21 describes the fields in the Optics module status window.

Table 21 Optics module status parameters

Field	Description
Laser Bias Current (ONT ANI-ONT-Side Optical Measurements)	Laser bias current, measured in uA
Optics Module Voltage (ONT ANI-ONT-Side Optical Measurements)	Optics module voltage, measured in V
Optics Module Temperature (ONT ANI-ONT-Side Optical Measurements)	Optics module temperature, measured in C
Rx Optics Signal Level at 1490 nm (ONT ANI-ONT-Side Optical Measurements)	Received optics signal level at 1490 nm, measured in dBm
Tx Optics Signal Level at 1310 nm (ONT ANI-ONT-Side Optical Measurements)	Transmitted optics signal level at 1310 nm, measured in dBm
Lower (ONT ANI-ONT-Side Optical Measurements-Optical Threshold)	Lower optical threshold, measured in dBm
Upper (ONT ANI-ONT-Side Optical Measurements-Optical Threshold)	Upper optical threshold, measured in dBm

2 Click Refresh to update the displayed information.

3 STOP. This procedure is complete.

Procedure 13 Statistics retrieval

- 1 Select Status > Statistics from the top-level menu in the 10G PON Gateway window, as shown in Figure 34.

Figure 34 Statistics window

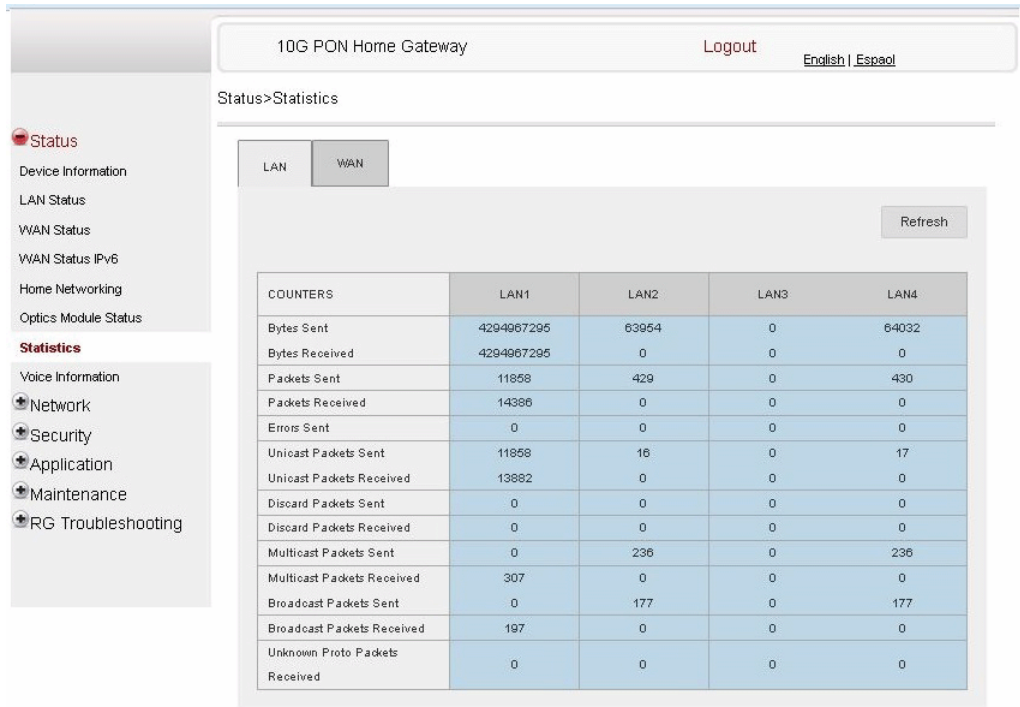

The Statistics window displays the statistical details for the WAN and each LAN line, such as the bytes, packets, and errors.

- 2 STOP. This procedure is complete.

Procedure 14 Voice information retrieval

- 1 Select Status > Voice Information from the top-level menu in the 10G PON Gateway window, as shown in Figure 35.

Figure 35 Voice Information window

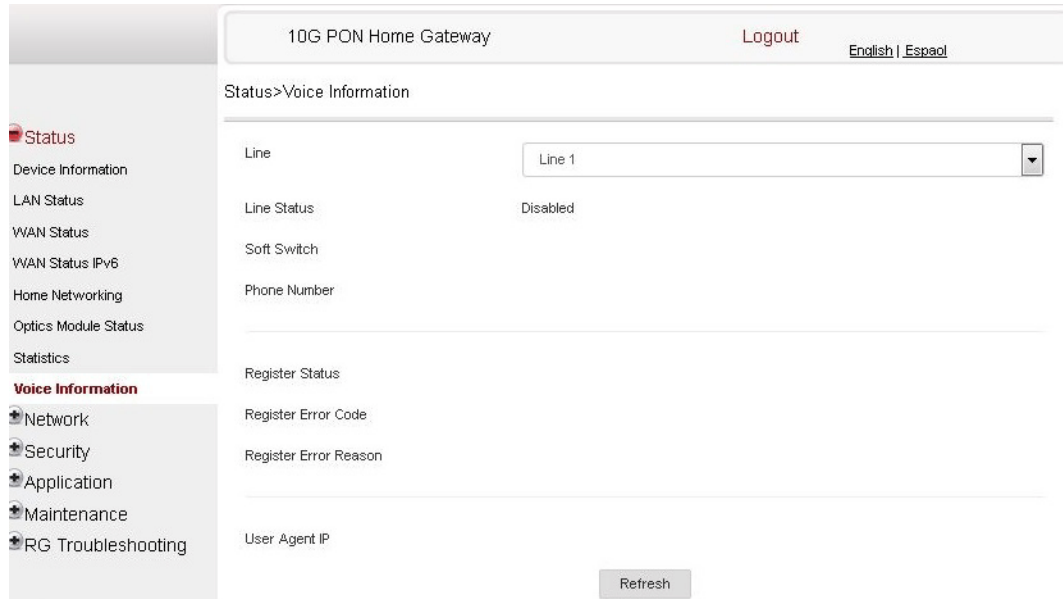

Table 22 describes the fields in the Voice Information window.

Table 22 Voice Information parameters

Field	Description
Line	Select the POTS line: 1 or 2
Line Status	Status of the selected POTS line: Disabled: the line is disabled Up: the line is registered Registering: the line is registering Error: the line failed to register
Softswitch ⁽¹⁾	Proxy IP address; blank if the line is not registered
Phone number ⁽¹⁾	Phone number configured for the selected telephone line
Register Status	Registration status of the selected POTS port: registered or unregistered
Register Error Code	Error code for the unregistered POTS port
User Agent	User Agent: IP

(1 of 2)

Field	Description
Register Error Reason	Error reason for the unregistered POTS port

(2 of 2)

Note

⁽¹⁾ This field is only visible at the adminPON level; it is not visible at the userAdmin level.

2 Click Refresh to update the displayed information.

3 STOP. This procedure is complete.

8.2.3 Network configuration

XS-240W-A and XS-250WX-A ONTs also support network configuration, including:

- LAN
- LAN IPv6
- WAN
- WAN DHCP
- Wireless 2.4GHz
- Wireless 5GHz
- wireless scheduling
- IP Routing
- DNS
- TR-069
- QoS

Procedure 15 LAN networking configuration

- 1 Select Network > LAN from the top-level menu in the 10G PON Gateway window, as shown in Figure 36.

Figure 36 LAN network window

Table 23 describes the fields in the LAN network window.

Table 23 LAN network parameters

Field	Description
All Ports to Bridge Mode	Select this checkbox to set all ports to bridge mode

(1 of 2)

Field	Description
Port Mode Port 1 - 4 and Port 5 (10G)	Drop-down port mode for each port: Route mode or bridge mode
IPv4 Address	IP Address of the ONT
Subnet Mask	Subnet mask of the ONT
DHCP enable	Select this checkbox to enable DHCP
DHCP Start IP Address	Starting DHCP IP address
DHCP End IP Address	Ending DHCP IP address
DHCP Lease Time	DHCP lease time (in min)
Primary DNS	Primary DNS identifier
Secondary DNS	Secondary DNS identifier
Static DHCP Entry MAC Address	MAC address for the static DHCP
Static DHCP Entry IPv4 Address	IPv4 address for the static DHCP

(2 of 2)

2 Select the mode for each port.

3 Click Save.

4 Enter the DHCP configuration information.

5 Click Save.

6 Enter the Static DHCP information.

7 Click Add.

You can also use this panel to delete a Static DHCP MAC address or IPv4 address.

8 STOP. This procedure is complete.

Procedure 16 LAN IPv6 networking configuration

- 1 Select Network > LAN_IPv6 from the top-level menu in the 10G PON Gateway window, as shown in Figure 37.

Figure 37 LAN IPv6 network window

Table 24 describes the fields in the LAN IPv6 network window.

Table 24 LAN IPv6 network parameters

Field	Description
DNS Server	Choose a DNS server from the drop-down menu.
prefix config	Choose a prefix config option from the drop-down menu, either WANConnection (prefix will be obtained from the WAN) or Static (enables you to enter the prefix).
prefix	This field appears if you selected the “Static” option for the “prefix config” field. Type a connection.
Interface	This field appears if you selected the Wan Connection option for the “prefix config” field. Choose a WAN connection interface from the drop-down menu.

(1 of 2)

Field	Description
DHCP Start IP Address	Enter the starting DHCP IP address.
DHCP End IP Address	Enter the ending DHCP IP address.
Whether the address info through DHCP	Select this checkbox to enable address information retrieval through DHCP.
Whether other info obtained through DHCP	Select this checkbox to enable retrieval of other information through DHCP.
Maximum interval for periodic RA messages	Enter the maximum interval (in seconds) for periodic Router Advertisement messages. The interval range is from 4 to 1800.
Minimum interval for periodic RA messages	Enter the minimum interval (in seconds) for periodic Router Advertisement messages. The interval range is from 4 to 1800.

(2 of 2)

2 Choose a DNS server, prefix config, and interface.

3 Select or enter the DHCP configuration information.

4 Enter the maximum and minimum intervals for RA messages.

5 Click Save/Apply.

6 STOP. This procedure is complete.

Procedure 17 WAN networking configuration

- 1 Select Network > WAN from the top-level menu in the 10G PON Gateway window, as shown in Figure 38.

Figure 38 WAN network window

Table 25 describes the fields in the WAN network window.

Table 25 WAN network parameters

Field	Description
WAN Connection List	Choose a WAN connection from the drop-down menu to set the connection parameters
Connection Type	Select a connection type: IPoE or PPPoE
IP Mode	Choose an IP mode from the drop-down menu: IPv4 or IPv6
Enable/Disable	Select this checkbox to enable the WAN connection
NAT	Select this checkbox to enable NAT
Service	Select the checkboxes to enable service types for this connection
Enable VLAN	Select this checkbox to enable VLAN
VLAN ID	Enter the VLAN ID
VLAN PRI	Enter the VLAN PRI

(1 of 2)

Field	Description
WAN IP Mode	Choose an IP mode from the drop-down menu
Manual DNS	Enter a DNS

(2 of 2)

2 Configure a specific WAN connection.

3 Click Save.

4 STOP. This procedure is complete.

Procedure 18 WAN DHCP configuration

- 1 Select Network > WAN DHCP from the top-level menu in the 10G PON Gateway window, as shown in Figure 39.

Figure 39 WAN DHCP window

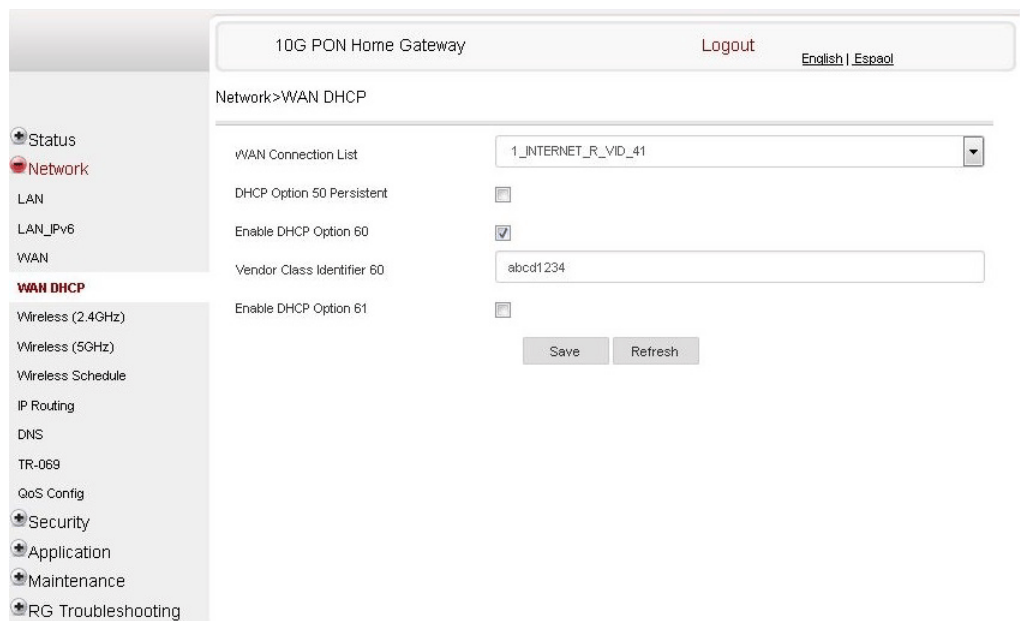

Table 26 describes the fields in the WAN DHCP window.

Table 26 WAN DHCP parameters

Field	Description
WAN Connection List	Choose a WAN connection from the drop-down menu
DHCP Option 50 persistent	Select this checkbox to enable DHCP Option 50
Enable DHCP Option 60	Select this checkbox to enable DHCP Option 60 (vendor class identifier)
Vendor Class Identifier 60	Enter the identifier for the vendor class
Enable DHCP Option 61	Select this checkbox to enable DHCP Option 61 (client identifier)

2 Configure a WAN DHCP option.

3 Click Save.

4 STOP. This procedure is complete.

Procedure 19 WiFi 2.4G networking configuration

- 1 Select Network > Wireless 2.4GHz from the top-level menu in the 10G PON Gateway window, as shown in Figure 40.

Figure 40 Wireless 2.4GHz network window

The screenshot shows the configuration interface for the 10G PON Home Gateway. The top navigation bar includes '10G PON Home Gateway', 'Logout', and language options 'English | Español'. The left sidebar contains a menu with items like Status, Network, LAN, WAN, and Wireless (2.4GHz). The main content area is titled 'Network > Wireless (2.4GHz)' and contains the following settings:

- Enable:**
- Mode:** auto(b/g/n)
- Bandwidth:** 20MHz
- Channel:** Auto
- Transmitting Power:** 100%
- WMM:** Enable
- Total MAX Users:** 32

SSID Configuration

- SSID Select:** SSID1
- SSID Name:** ALHN-1983
- Enable SSID:** Enable
- SSID Broadcast:** Enable
- Port Mode:** Route
- MAX Users:** 32
- Encryption Mode:** WPA/WPA2 Personal
- WPA Version:** WPA/WPA2
- WPA Encryption Mode:** TKIP/AES
- WPA Key:** [Masked]
- Show password:**
- Enable WPS:** Disable

Buttons for 'Save' and 'Refresh' are located at the bottom right of the configuration area.

Table 27 describes the fields in the Wireless 2.4GHz network window.

Table 27 Wireless 2.4GHz network parameters

Field	Description
Enable	Select this checkbox to enable WiFi

(1 of 2)

Field	Description
Mode	Choose a Wi-Fi mode from the drop-down menu: <ul style="list-style-type: none"> • auto (b/g/n) • b • g • n • b/g
Bandwidth	Choose from: <ul style="list-style-type: none"> • 20 MHz • 40 MHz • 20/40 MHz
Channel	Choose a channel from the drop-down menu or choose Auto to have the channel automatically assigned
Transmitting Power	Choose a percentage for the transmitting power from the drop-down menu: <ul style="list-style-type: none"> • Low (25%) • Medium (50%) • High (75%) • Maximum (100%)
WMM	Select this checkbox to enable or disable wireless multi media
Total MAX Users	Enter the total number of MAX users
SSID Select	Choose the SSID from the drop-down menu
SSID Name	Enter the SSID name
Enable SSID	Enable or disable SSID from this drop-down menu
SSID Broadcast	Enable or disable SSID broadcast from this drop-down menu
Port Mode	Choose a port mode from the drop-down menu: <ul style="list-style-type: none"> • Route • Bridge
MAX Users	Enter the number of MAX users
Encryption Mode	Choose an encryption mode from the drop-down menu: <ul style="list-style-type: none"> • OPEN • WEP • WPA/WPA2 Personal • WPA/WPA2 Enterprise ⁽¹⁾(2)
WPA Version	Choose a WPA version from the drop-down menu: <ul style="list-style-type: none"> • WPA1 • WPA2 • WPA1/WPA2
WPA Encryption Mode	Choose a WPA encryption mode from the drop-down menu: <ul style="list-style-type: none"> • TKIP • AES • TKIP/AES
WPA Key	Enter the WPA key
Enable WPS	Enable or disable WPS from this drop-down menu

(2 of 2)

Notes

- (1) When Encryption Mode is set to "WPA/WPA2 Enterprise", the following options are no longer available: WPA version, WPA encryption mode, WPA key, Enable WPS, WPS mode.
- (2) When Encryption Mode is set to "WPA/WPA2 Enterprise", the following options become available: Primary RADIUS server, port and password; Secondary RADIUS server, port, and password; RADIUS accounting port.

2 Configure the wireless 2.4 GHz connection.

3 If you have enabled and configured WPS, click WPS connect.

4 Click Save.

5 STOP. This procedure is complete.

Procedure 20 Wireless 5GHz networking configuration

- 1 Select Network > Wireless 5GHz from the top-level menu in the 10G PON Gateway window, as shown in Figure 41.

Figure 41 Wireless 5GHz network window

The screenshot shows the configuration interface for the 10G PON Home Gateway. The main title is "10G PON Home Gateway" with "Logout" and language options "English | Español". The navigation menu on the left includes Status, Network (selected), LAN, LAN IPv6, WAN, WAN DHCP, Wireless (2.4GHz), **Wireless (5GHz)**, Wireless Schedule, IP Routing, DNS, TR-069, QoS Config, Security, Application, Maintenance, and RG Troubleshooting. The main content area is titled "Network > Wireless (5GHz)".

Wireless (5GHz) Settings:

- Enable:
- Bandwidth: 80MHz
- Channel: Auto
- Transmitting Power: 100%
- WMM: Enable
- Enable MU-MIMO: Disable
- Total MAX Users: 32
- DFS re-entry: Enable

SSID Configuration:

- SSID Select: SSID5
- SSID Name: ALHN-1983-5
- Enable SSID: Enable
- SSID Broadcast: Enable
- Port Mode: Route
- MAX Users: 32
- Encryption Mode: WPA2-AES
- WPA Key:
- Show password:
- Enable WPS: Disable

Buttons: Save, Refresh

Table 28 describes the fields in the Wireless 5GHz network window.

Table 28 Wireless 5GHz network parameters

Field	Description
Enable	Select this checkbox to enable WiFi

(1 of 2)

Field	Description
Bandwidth	Choose from: <ul style="list-style-type: none"> • 20 MHz • 40 MHz • 80 MHz
Channel	Choose a channel from the drop-down menu or choose Auto to have the channel automatically assigned
Transmitting Power	Choose a percentage for the transmitting power from the drop-down menu: <ul style="list-style-type: none"> • Low (20%) • Medium (40%) • High (60%) • Maximum (100%)
WMM	Select this checkbox to enable or disable wireless multi media
Enable MU-MIMO	Choose Enable or disable MU-MIMO from this drop-down menu The default is Enable, which enables users and wireless terminals to communicate with each other. MU-MIMO may decrease Wi-Fi performance for clients who do not support it, in which case Nokia recommends that you choose Disable.
Total MAX Users	Enter the total number of MAX users
DFS re-entry	Select this checkbox to enable or disable DFS re-entry
SSID Select	Choose the SSID from the drop-down menu
SSID Name	Change the name of the selected SSID
Enable SSID	Choose Enable or disable SSID from this drop-down menu
SSID Broadcast	Choose Enable or disable SSID broadcast from this drop-down menu
Port Mode	Choose Route or Bridge from the drop-down menu
MAX Users	Enter the number of MAX users
Encryption Mode	Choose an encryption mode from the drop-down menu: <ul style="list-style-type: none"> • OPEN • WEP • WPA/WPA2 Personal • WPA/WPA2 Enterprise ⁽¹⁾⁽²⁾
WPA Key	Enter the WPA key
Enable WPS	Choose Enable or disable WPS from this drop-down menu

(2 of 2)

Notes

- (1) When Encryption Mode is set to "WPA/WPA2 Enterprise", the following options are no longer available: WPA version, WPA encryption mode, WPA key, Enable WPS, WPS mode.
- (2) When Encryption Mode is set to "WPA/WPA2 Enterprise", the following options become available: Primary RADIUS server, port and password; Secondary RADIUS server, port, and password; RADIUS accounting port.

2 Configure the wireless 5GHZ connection.

3 If you have enabled and configured WPS, click WPS connect.

-
- 4 Click Save.
 - 5 STOP. This procedure is complete.
-

Procedure 21 Wireless scheduling

-
- 1 Select Network > Wireless Schedule from the top-level menu in the 10G PON Gateway window, as shown in Figure 42.

Figure 42 Wireless Schedule network window

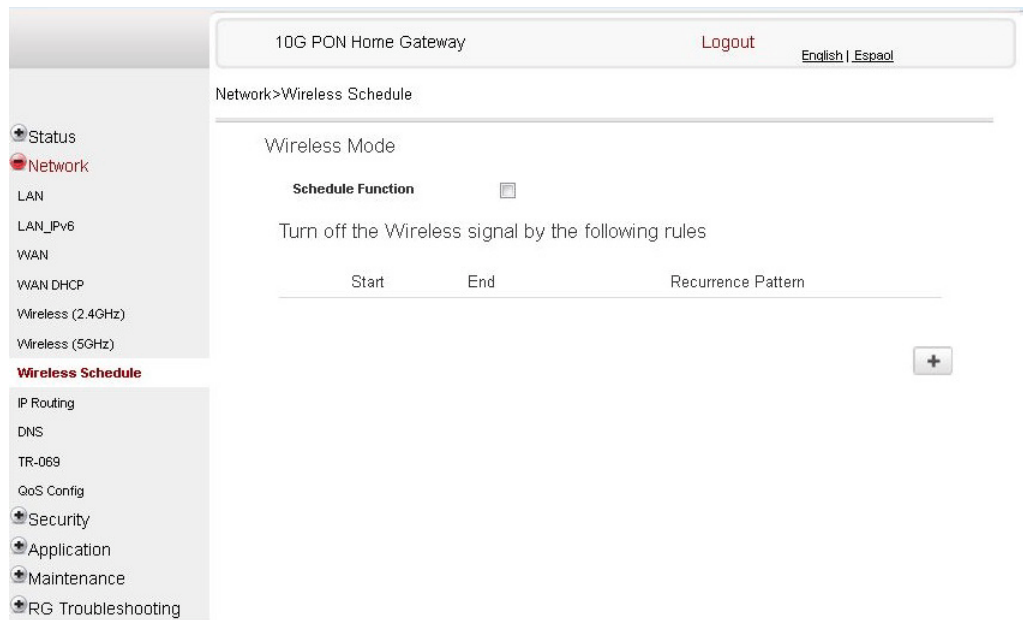

-
- 2 Select the Schedule Function checkbox to turn the wireless signal off for the configured period.
 - 3 Select the Start, End, and Recurrence Pattern rules for turning the wireless signal off.
 - 4 Click Save.
 - 5 STOP. This procedure is complete.
-

Procedure 22 IP Routing configuration

Note that forwarding policy is not supported in Release 5.6.

- 1 Select Network > IP Routing from the top-level menu in the 10G PON Gateway window, as shown in Figure 43.

Figure 43 IP Routing network window

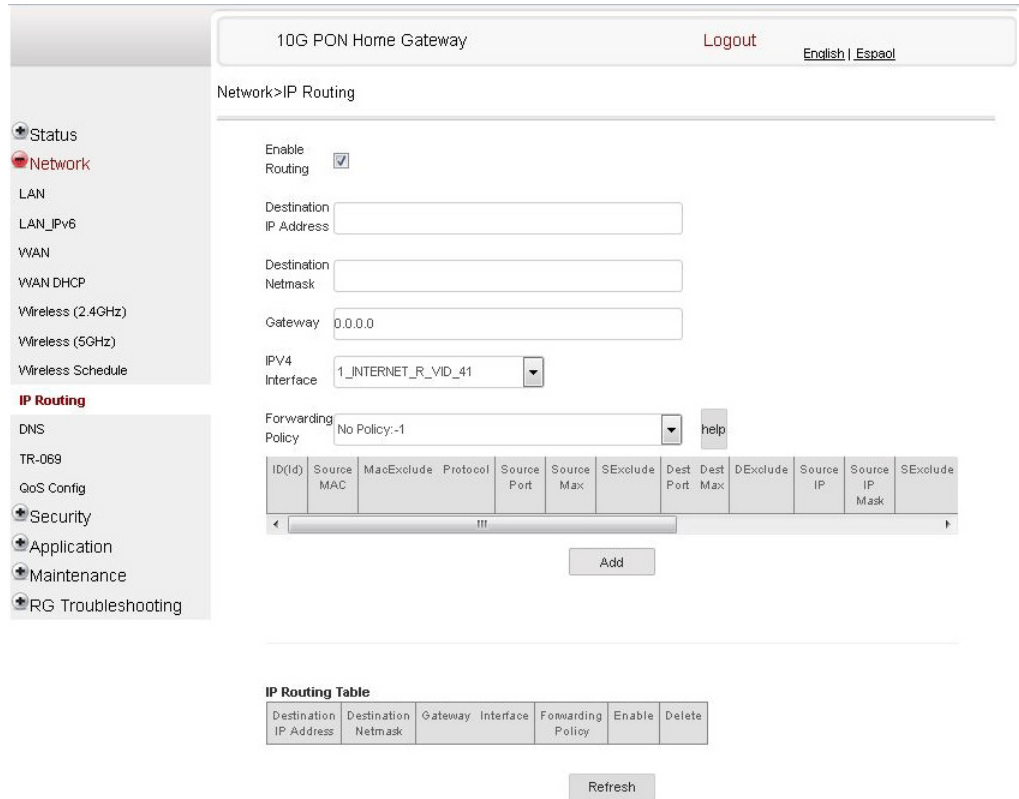

Table 29 describes the fields in the IP Routing network window.

Table 29 IP Routing network parameters

Field	Description
Enable Routing	Select this checkbox to enable routing
Destination IP Address	Enter the destination IP address
Destination Netmask	Enter the destination network mask
Gateway	Enter the gateway address

(1 of 2)

Field	Description
IPv4 Interface	Choose a WAN connection previously created in the WAN network window from the drop-down menu

(2 of 2)

- 2 Enter the routing information.
- 3 Click Add.
- 4 STOP. This procedure is complete.

Procedure 23 DNS configuration

- 1 Select Network > DNS from the top-level menu in the 10G PON Gateway window, as shown in Figure 44.

Figure 44 DNS network window

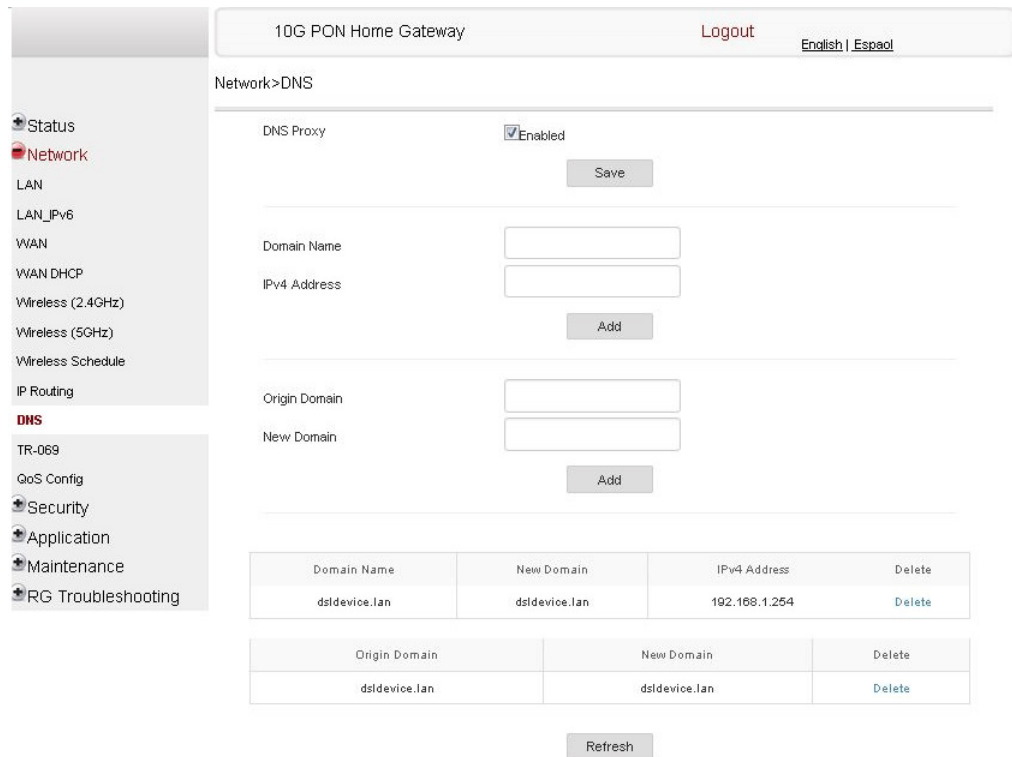

Table 30 describes the fields in the DNS network window.

Table 30 DNS network parameters

Field	Description
DNS Proxy Enabled	Select this checkbox to enable DNS proxy
Domain Name	Domain name
IPv4 Address	Domain IP address
Origin Domain	Origin domain name
New Domain	New domain name

2 Enter the domain name and IP address and click Add.

3 If required, associate an origin domain with a new domain, click Add.

4 STOP. This procedure is complete.

Procedure 24 TR-069 configuration

- 1 Select Network > TR-069 from the top-level menu in the 10G PON Gateway window, as shown in Figure 45.

Figure 45 TR-069 network window

Table 31 describes the fields in the TR-069 network window.

Table 31 TR-069 network parameters

Field	Description
Periodic Inform Enable	Select this checkbox to enable periodic inform updates
Periodic Inform Interval(s)	Time between periodic inform updates, in seconds
URL	URL of the auto-configuration server
Username	Username used to log in to the auto-configuration server
Password	Password used to log in to the auto-configuration server
Connect Request Username	Username used to log in to the ONT
Connect Request Password	Password used to log in to the ONT

- 2 Configure TR-069 by entering the required information.

3 Click Save.

4 STOP. This procedure is complete.

Procedure 25 QoS configuration

Note that forwarding policy is not supported in Release 5.6.

1 Select Network > QoS Config from the top-level menu in the 10G PON Gateway window.

Figure 46 shows the QoS Config window for QoS L2 (Layer 2 packet sizes).

The window for QoS L3 shows additional fields, as described in Table 32.

Figure 46 QoS Config window (L2)

The screenshot shows the '10G PON Home Gateway' interface with the 'Network > QoS Config' menu selected. The 'QoS Setting' section includes a table with the following columns: ID(Id), Source MAC, Source MAC Exclude, Protocol, Source Port, Source Max, SEclude, Dest Port, Dest Max, DEclude, and So I. Below the table, the 'Type' is set to 'L2 QoS'. Other fields include 'Source MAC' with an 'Exclude' checkbox, 'Interface' set to '-- select an option', '802.1p Mark' (Range: 0-7), 'DSCP Mark' (Range: 0-63), and 'Forwarding Policy' (Range: 1-7). An 'Add' button is located at the bottom right of the settings area.

Table 32 describes the fields in the QoS Config window.

Table 32 QoS Config parameters

Field	Description
Type	Choose a QoS type from the drop-down menu: L2 or L3
Source MAC	Enter the source MAC. Select the Exclude checkbox to exclude the source MAC
Interface	Choose an interface from the drop-down menu
802.1p Mark	Enter the value for the 802.1p (range: 0-7)
DSCP Mark	Enter the value for the DSCP mark (range: 0-63)
Additional fields for L3	
Protocol	Select a protocol from the drop-down menu, or select the Exclude checkbox
Application	Select an application from the drop-down menu
Source IP and Source IP Mask	Enter the values for the source IP and IP mask, or select the Exclude checkbox
Destination IP and Destination IP Mask	Enter the values for the destination IP and IP mask, or select the Exclude checkbox
Source Port and Source Port Max	Enter the values for the source port and port max (highest port number) or select the Exclude checkbox
Destination Port and Destination Port Max	Enter the values for the destination port and port max (highest port number), or select the Exclude checkbox

2 Choose a QoS type from the drop-down menu: L2 or L3.

3 Configure a QoS policy.

4 Click Add to add a QoS policy.

5 STOP. This procedure is complete.

8.2.4 Security configuration

XS-240W-A and XS-250WX-A ONT also supports security configuration, including:

- firewall
- MAC filter
- IP filter
- URL filter

- DMZ and ALG
- access control

Note that parent control is not supported in Release 5.6.

Procedure 26 Firewall configuration

- 1 Select Security > Firewall from the top-level menu in the 10G PON Gateway window, as shown in Figure 47.

Figure 47 Firewall window



Firewall security applies only to services provided by the ONT. Internet access from the LAN side is not affected by this firewall.

Three security levels are available: Low, Medium, and High.

At the Low level, pre-routing is supported: port forwarding, DMZ, host application, and host drop. Also supported are application services: DDNS, DHCP, DNS, H248, IGMP, NTP client, SSH, Telnet, TFTP, TR-069, and VoIP.

At the Medium level, pre-routing is supported: port forwarding, DMZ, host application, and host drop. Also supported are application services: DDNS, DHCP, DNS, H248, IGMP, NTP client, TFTP, TR-069, and VoIP. The following types of ICMP messages are permitted: echo request and reply, destination unreachable, and TTL exceeded. Other types of ICMP messages are blocked. DNS proxy is supported from LAN to WAN but not from WAN to LAN.

At the High level, pre-routing and application services are not supported. UDP Port 8000 can be used to access the services, for example FTP can use 8021 and Telnet can use 8023. Regular UDP cannot be used. RG access is permitted via the LAN side but not via the WAN side.

Table 33 describes the fields in the firewall window.

Table 33 Firewall parameters

Field	Description
Security level	Choose the security level from the drop-down menu: low, medium, or high
Attack Protect (Protection against DoS or DDoS attacks)	Choose enable or disable attack protect from the drop-down menu The default is disable

- 2 Configure the firewall.
- 3 Click Save.
- 4 STOP. This procedure is complete.

Procedure 27 MAC filter configuration

- 1 Select Security > Mac Filter from the top-level menu in the 10G PON Gateway window, as shown in Figure 48.

Figure 48 MAC filter window

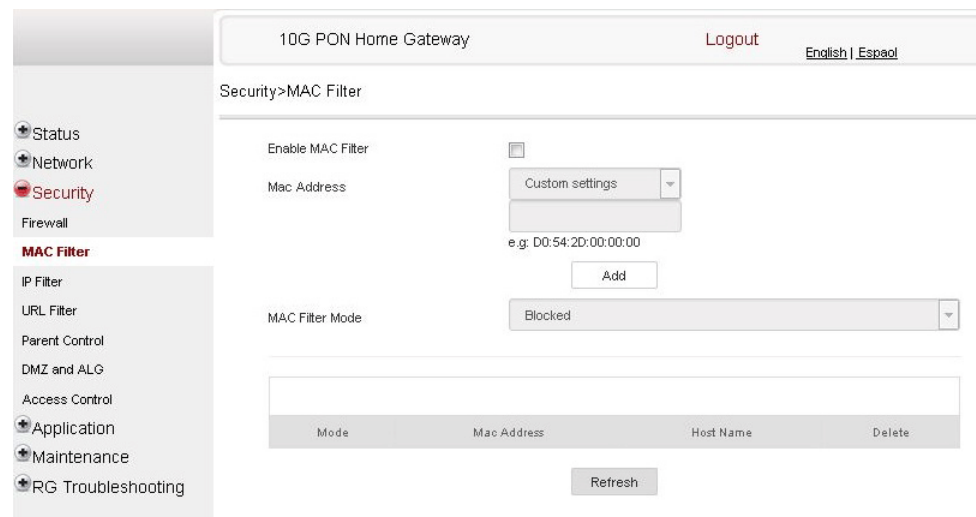

Table 34 describes the fields in the MAC filter window.

Table 34 MAC filter parameters

Field	Description
Enable MAC filter	Select this checkbox to enable the MAC filter
Mac Address	Select a MAC address from the drop-down menu or enter the address in the text field
Mac Filter Mode	Choose the MAC filter mode from this drop-down menu: Blocked or Allowed

- 2 Click Refresh to update the information.
- 3 Configure a MAC filter.
- 4 Click Add.
- 5 STOP. This procedure is complete.

Procedure 28 IP filter configuration

- 1 Select Security > IP filter from the top-level menu in the 10G PON Gateway window, as shown in Figure 49.

Figure 49 IP filter window

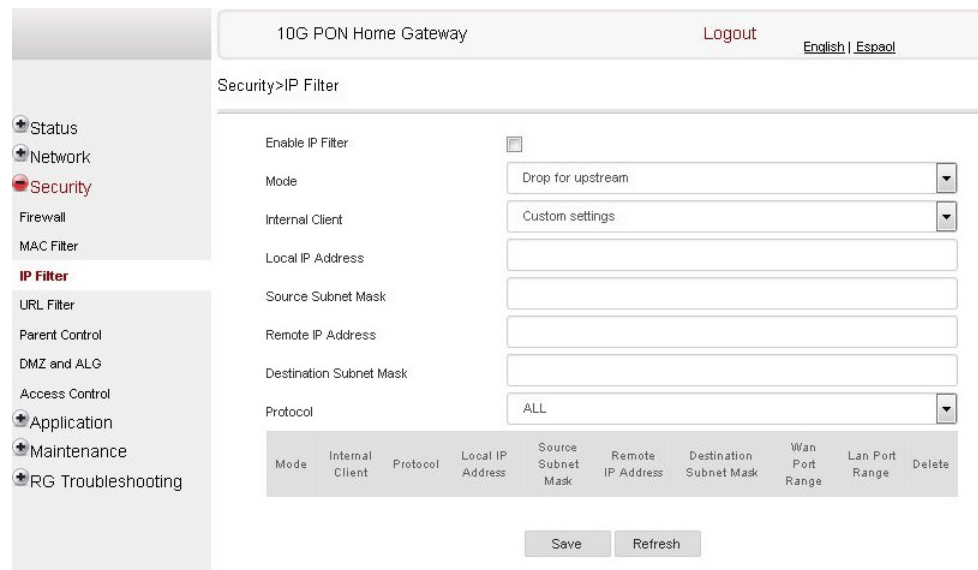

Table 35 describes the fields in the IP filter window.

Table 35 IP filter parameters

Field	Description
Enable IP Filter	Select this checkbox to enable an IP filter
Mode	Choose an IP filter mode from the drop-down menu: <ul style="list-style-type: none"> Drop for upstream Drop for downstream
Internal Client	Choose an internal client from the drop-down menu: <ul style="list-style-type: none"> Customer setting - uses the IP address input below IP - uses the connecting devices' IP to the ONT
Local IP Address	Local IP address
Source Subnet Mask	Source subnet mask
Remote IP Address	Remote IP address
Destination Subnet Mask	Destination subnet mask
Protocol	Choose an application protocol or all from the drop-down menu

2 Configure the IP filter.

3 Click Add.

4 STOP. This procedure is complete.

Procedure 29 URL filter configuration

- 1 Select Security > URL Filter from the top-level menu in the 10G PON Gateway window, as shown in Figure 50.

Figure 50 URL Filter window



Note — You cannot use URL filtering for HTTPS. The URL is encrypted when using HTTPS.

Table 36 describes the fields in the URL Filter window.

Table 36 URL Filter parameters

Field	Description
Enable URL filter	Select the checkbox to enable the URL filter
URL filter type	Select the checkbox for Exclude URL or Include URL
URL Address	Type the URL address
Port Number	Type the port number; the default is 80

- 2 Configure the URL Filter.

- 3 Click Add Filter.
- 4 STOP. This procedure is complete.

Procedure 30 DMZ and ALG configuration

- 1 Select Security > DMZ and ALG from the top-level menu in the 10G PON Gateway window, as shown in Figure 51.

Figure 51 DMZ and ALG window

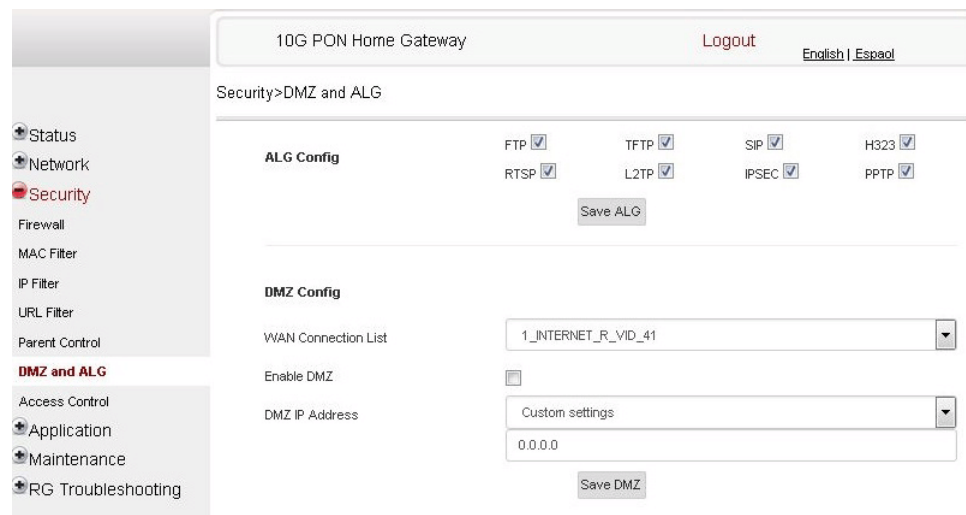

Table 37 describes the fields in the DMZ and ALG window.

Table 37 DMZ and ALG parameters

Field	Description
ALG Config	Select the checkboxes to enable the protocols to be supported by the ALG: FTP, TFTP, SIP, H323, RTSP, L2TP, IPSEC, PPTP
DMZ Config	
WAN Connection List	Choose a WAN connection from the drop-down menu
Enable DMZ	Select this checkbox to enable DMZ on the chosen WAN connection
DMZ IP Address	Choose Customer Setting and enter the DMZ IP address or choose the IP address of a connected device from the drop-down menu

-
- 2** Configure ALG.

 - 3** Click Save ALG.

 - 4** Configure DMZ.

 - 5** Click Save DMZ.

 - 6** STOP. This procedure is complete.

Procedure 31 Access control configuration

This procedure describes how to configure the access control level (ACL).



Note 1 — ACL takes precedence over the firewall policy.

Note 2 — The trusted network object will be shared for all WAN connections; it is not applied individually to a WAN connection.

- 1 Select Security > Access Control from the top-level menu in the 10G PON Gateway window, as shown in Figure 52.

Figure 52 Access Control window

Table 38 describes the fields in the Access Control window.

Table 38 Access control parameters

Field	Description
WAN	Choose a connection from the drop-down menu
Trusted Network Enable	Select this checkbox to enable trusted network

(1 of 2)

Field	Description
ICMP, Telnet, SSH, HTTP, TR-069, HTTPS	Select an access control level for each protocol: WAN side: Allow, Deny, or Trusted Network Only LAN side: Allow or Deny
Source IP Start	Enter a start IP address for the new subnet trusted network
Source IP End	Enter an end IP address for the new subnet trusted network

(2 of 2)

-
- 2 Select a WAN connection from the drop-down menu.

 - 3 Select the checkbox to enable Trusted Network.

 - 4 Select an access control level for each of the four protocols: ICMP, SSH, HTTP, and TR-069 for both the WAN and the LAN side.

 - 5 Click Save.

 - 6 Optionally, add one or more subnet trusted networks.

The maximum number of entries is 32.

You can also use the Source IP fields to delete a previously created entry for a subnet trusted network.

 - 7 STOP. This procedure is complete.
-

8.2.5 Application configuration

XS-240W-A and XS-250WX-A ONT also supports application configuration, including:

- port forwarding
- DDNS
- NTP
- USB
- UPnP and DLNA
- voice setting

Note that port triggering is not supported in release 5.6.

Procedure 32 Port forwarding configuration

- 1 Select Application > Port forwarding from the top-level menu in the 10G PON Gateway window, as shown in Figure 53.

Figure 53 Port forwarding window

The screenshot shows the '10G PON Home Gateway' web interface. The top navigation bar includes 'Logout' and language options 'English | Español'. The left sidebar menu is expanded to 'Application', with 'Port Forwarding' highlighted. The main content area is titled 'Application>Port Forwarding' and contains the following configuration fields:

- Application Name:** A dropdown menu currently set to 'Custom settings'.
- WAN Port:** Two empty text input boxes separated by a tilde (~).
- LAN Port:** Two empty text input boxes separated by a tilde (~).
- Internal Client:** A dropdown menu set to 'Custom settings' and an empty text input box.
- Protocol:** A dropdown menu set to 'TCP'.
- Enable Mapping:** An unchecked checkbox.
- WAN Connection List:** A dropdown menu set to '1_INTERNET_R_VID_41'.

Below the fields is an 'Add' button. At the bottom of the window is a table with the following columns: Application Name, WAN Connection, WAN Port, LAN Port, Device Name, Internal Client, Protocol, Status, and Delete.

Table 39 describes the fields in the port forwarding window.

Table 39 Port forwarding parameters

Field	Description
Application Name	Choose an application name from the drop-down menu
WAN Port	WAN port range
LAN Port	LAN port range
Internal Client	Choose a connected device from the drop-down menu and enter the associated IP address
Protocol	Choose the port forwarding protocol from the drop-down menu: <ul style="list-style-type: none"> • TCP • UDP • TCP/UDP
Enable Mapping	Select this checkbox to enable mapping
WAN Connection List	Choose a WAN connection from the drop-down menu Note: only active devices are shown on this menu

- 2 Configure port forwarding.
- 3 Click Add.
- 4 STOP. This procedure is complete.

Procedure 33 DDNS configuration

- 1 Select Application > DDNS from the top-level menu in the 10G PON Gateway window, as shown in Figure 54.

Figure 54 DDNS window

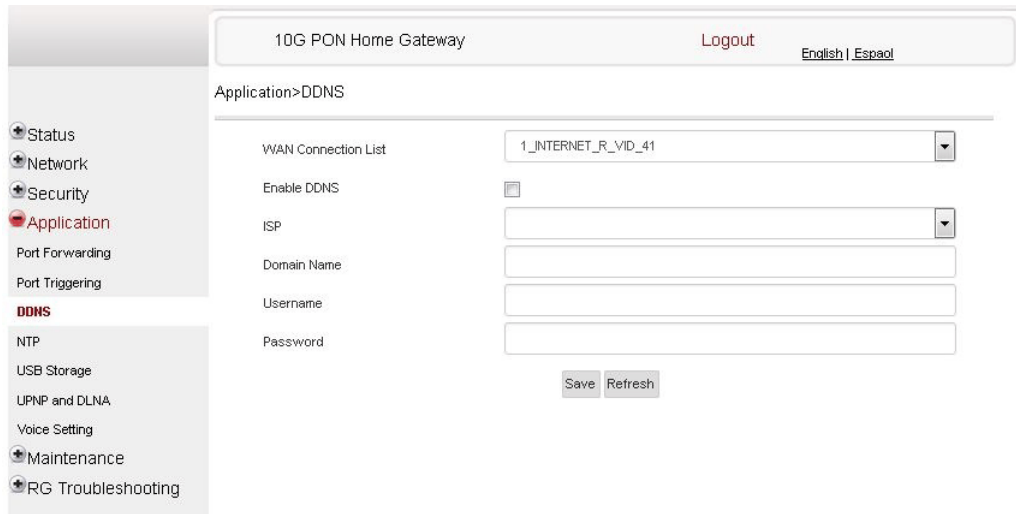

Table 40 describes the fields in the DDNS window.

Table 40 DDNS parameters

Field	Description
WAN Connection List	Choose a WAN connection from the drop-down menu
Enable DDNS	Select this checkbox to enable DDNS on the chosen WAN connection
ISP	Choose an ISP from the drop-down menu.
Domain Name	Domain name
Username	Username

(1 of 2)

Field	Description
Password	Password

(2 of 2)

-
- 2 Configure DDNS.

 - 3 Click Save.

 - 4 STOP. This procedure is complete.
-

Procedure 34 NTP configuration

-
- 1 Select Application > NTP from the top-level menu in the 10G PON Gateway window, as shown in Figure 55.

Figure 55 NTP window

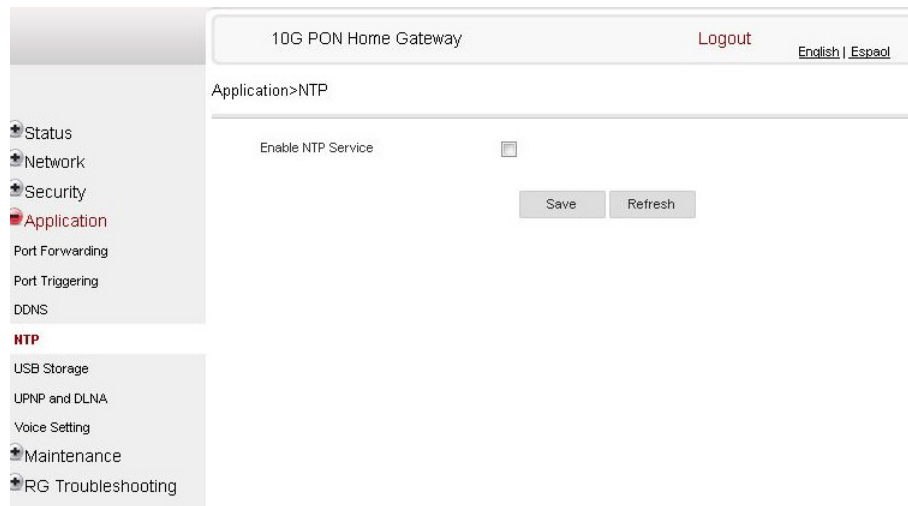

-
- 2 Select the checkbox to enable NTP service.

 - 3 Click Save.

 - 4 STOP. This procedure is complete.
-

Procedure 35 USB configuration

You can connect USB storage devices and USB printers to the USB ports of the device. The USB menu enables you to configure FTP and SFTP servers for your USB storage devices.

You can also use the USB menu to enable and disable USB printer sharing across clients on the LAN.

The USB connected devices are shown in overview table on the bottom of the USB window.

The device incorporates a CUPS server to enable USB printer sharing across the LAN by using the RAW print-through protocol. When a USB printer is connected to the device, it can be configured on LAN clients by referring to

`http://<hostname>:631/printers/<printer_name>`

as a shared printer, where <hostname> refers to the DNS name or the IP address of the device and the <printer_name> is displayed in the connected USB device table of the USB page. The USB printer driver must be installed on the LAN client to execute print jobs. When an error prevents the print job from being completed, a generic error message is returned to the LAN client. Up to four print jobs at a time are supported.

- 1 Select Application > USB from the top-level menu, as shown in Figure 56.

Figure 56 USB window

The screenshot shows the 'Application > USB' configuration page. On the left is a navigation menu with 'USB' selected. The main area contains the following settings:

- Enable FTP Server:**
 - Username: ftpadmin
 - Password: [masked]
 - Re-enter Password: [masked]
- Enable SFTP Server:**
 - Enable SFTP for Remote Access:
 - Username: sftpadmin
 - Password: [masked]
 - Re-enter Password: [masked]
- Enable Printer Sharing:**

Below the settings is a table titled 'Connected USB Devices Table':

Host Number	Device Name	Format	Total Space	Free Space
USB1	USB1_1	FAT	1.9GB	1.4GB

At the bottom of the table are 'Save' and 'Refresh' buttons.

Table 41 describes the fields in the USB window.

Table 41 USB parameters

Field	Description
Enable FTP server	Select this checkbox to enable using an FTP server
Username	Username for FTP server
Password	Password for FTP server
Re-enter Password	Password for FTP server
Enable SFTP server	Select this checkbox to enable using an SFTP server
Enable SFTP for Remote Access	Select this checkbox to enable SFTP for remote access
Username	Username for SFTP server
Password	Password for SFTP server
Re-enter Password	Password for SFTP server
Enable Printer Sharing	Select this checkbox to enable printer sharing Printer sharing is disabled by default
Connected USB devices	For each printer that is connected to the ONT, the following fields are displayed: <ul style="list-style-type: none"> • Host Number for example: Printer1, Printer2 • Device Name: name or identification for the USB device • Format: for a USB printer, the printing protocol is RAW; for a USB storage device, this field displays the storage format • Total space (applies only to a USB storage device) • Free space (applies only to a USB storage device)

2 Configure USB.

3 Click Save.

4 STOP. This procedure is complete.

Procedure 36 UPNP and DLNA configuration

- 1 Select Application > UPNP and DLNA from the top-level menu in the 10G PON Gateway window, as shown in Figure 57.

Figure 57 UPNP and DLNA window

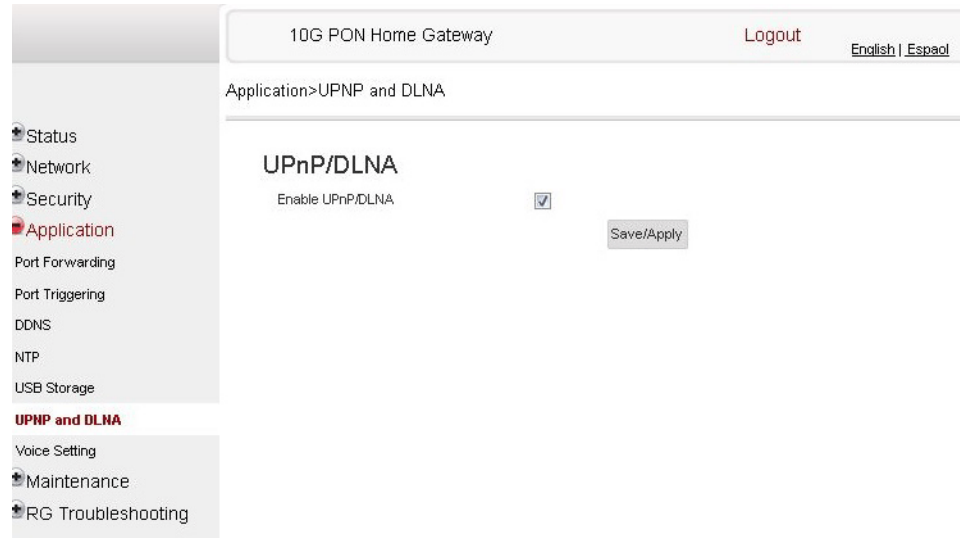

- 2 Select the Enable UPnP checkbox to enable UPnP.
 - 3 Click Save/Apply.
 - 4 STOP. This procedure is complete.
-

Procedure 37 Voice setting

Voice setting can only be uses in TR-069 mode.

- 1 Select Application > Voice Setting from the top-level menu in the 10G PON Gateway window, as shown in Figure 58.

Figure 58 Voice setting window

The screenshot shows the 'Voice Setting' configuration window. On the left is a navigation menu with 'Application' selected. The main area is titled 'Application>Voice Setting' and contains the following fields:

- Voice Setting:**
 - OutboundProxy: [Empty text box]
 - OutboundProxyPort: [5060]
 - Proxy Server: [Empty text box]
 - Proxy Port: [5060]
 - Register Server: [Empty text box]
 - Register Port: [5060]
 - UserAgentDomain: [Empty text box]
 - DigitMap: [*(X|*#X|*X#|XXXXXXXXXX)(88885010)E|0901XXXXXXXXXXXX|0901XXXXXXXXXX|0900X.T|09020|090|3-8|[0-3]|0903|4-9|0904|6-9|090|5-8|[4-9]|09090|0902|1-9|XXXXXXXXXX|0909|1-9|X.T|X.T]
 - DTMF mode: [RFC2833]
 - FaxT38: [True]
- Line Setting:**
 - Line: [Line1]
 - Enable: [Disabled]
 - Directory Number: [Empty text box]
 - AuthUserName: [Empty text box]
 - AuthPassword: [Empty text box]

Table 42 describes the fields in the Voice Setting window.

Table 42 Voice setting parameters

Field	Description
Outbound Proxy	Enter the SIP outbound proxy
Outbound Proxy Port	Enter the outbound proxy port
Proxy Server	Enter the proxy server
Proxy Port	Enter the proxy port
Register Server	Enter the register server
Register Port	Enter the register port
User Agent Domain	Enter the user agent domain
DTMF Mode	Choose InBand, rfc2822, Info, or Auto from the drop-down menu
FaxT38	Choose False or True from the drop-down menu
Line	Choose a line from the drop-down menu
Enable	Choose Enabled or Disabled from the drop-down menu
Directory Number	Enter a directory number
AuthUserName	Enter an authorized user name
AuthPassword	Enter a password for the user

2 Configure voice setting.

3 Click Save.

4 STOP. This procedure is complete.

8.2.6 Maintenance

XS-240W-A and XS-250WX-A ONT also supports maintenance tasks, including:

- change password
- configure LOID
- configure SLID
- manage device
- backup and restore
- upgrade firmware
- reboot device
- restore factory defaults

- diagnose WAN connections
- view log

Procedure 38 Password configuration

A password must adhere to the password rules, which are as follows:

- the password may consist of uppercase letters, lowercase letters, digital numbers, and the following special characters **! # + , - / @ _ : =]**
- the password length must be from 8 to 24 characters
- the first character must be a digital number or a letter
- the password must contain at least two types of characters: numbers, letters, or special characters
- the same character must not appear more than 8 times in a row

When the password meets the password rules, the application displays the message “Your password has been changed successfully”.

When the password does not meet the password rules, the application displays a message to indicate which password rule has not been followed, for example:

- the password is too short
- the password is too long
- the first character cannot be a special character
- there are not enough character classes

-
- 1** Select Maintenance > Password from the top-level menu in the GPON Home Gateway window, as shown in Figure 59.

Figure 59 Password window

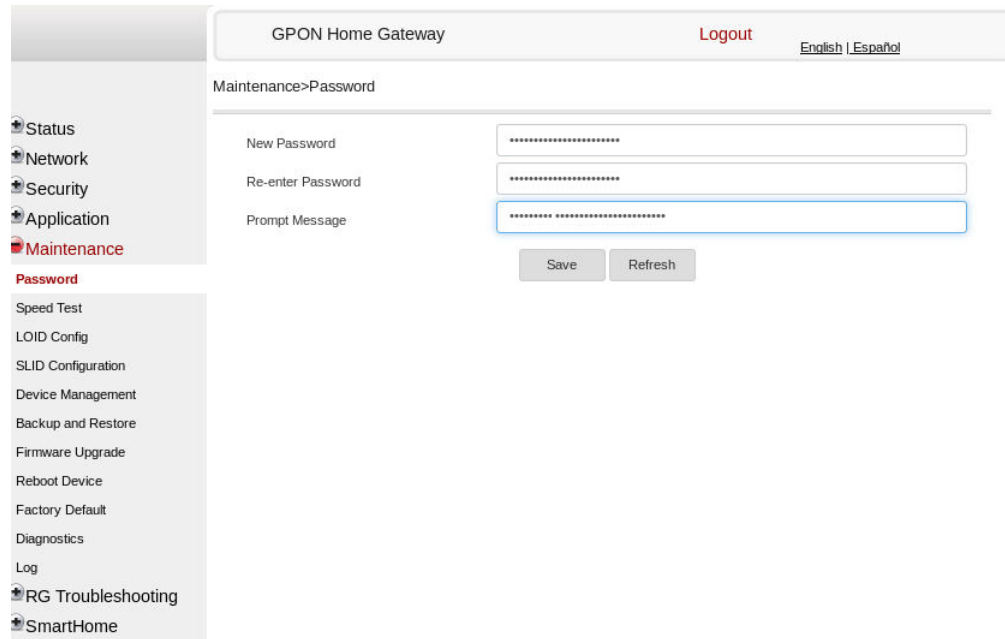

Table 43 describes the fields in the password window.

Table 43 Password parameters

Field	Description
New Password	New password (must adhere to the password rules described above)
Re-enter password	Must match the new password entered above exactly
Prompt message	Password prompt message

- 2 Configure the new password.
- 3 Click Save.
- 4 STOP. This procedure is complete.

Procedure 39 LOID configuration

- 1 Select Maintain > LOID Config from the top-level menu in the 10G PON Gateway window, as shown in Figure 60.

Figure 60 LOID Config window

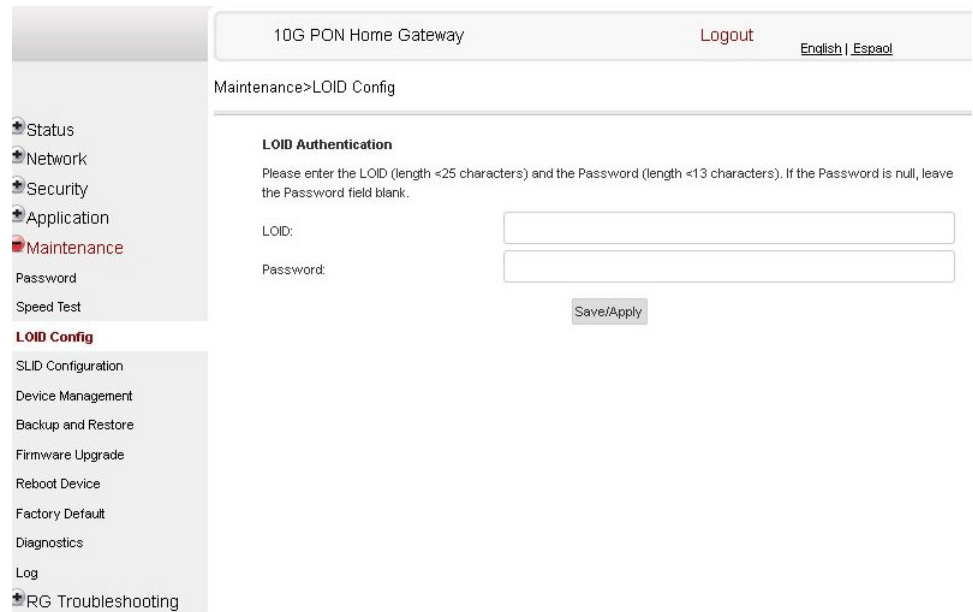

Table 44 describes the fields in the LOID configuration window.

Table 44 LOID configuration parameters

Field	Description
LOID	Type the LOID; the maximum number of characters is 24 If the password is null, this field may be left blank
Password	Type the password; the maximum number of characters is 12

- 2 Configure the LOID.
- 3 Click Save/Apply.
- 4 STOP. This procedure is complete.

Procedure 40 SLID configuration

- 1 Select Maintain > SLID Configuration from the top-level menu in the 10G PON Gateway window, as shown in Figure 61.

Figure 61 SLID configuration window

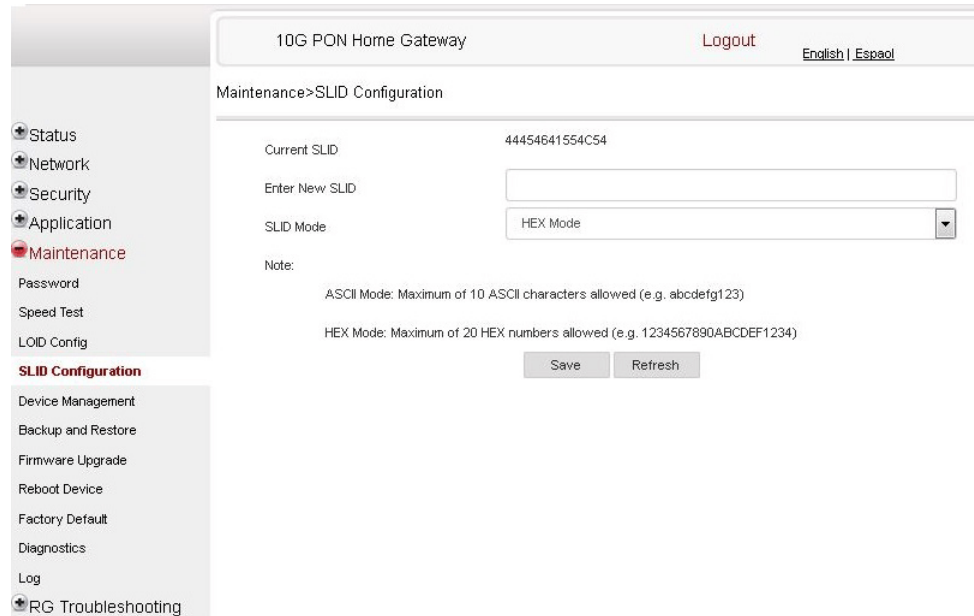

Table 45 describes the fields in the SLID configuration window.

Table 45 SLID configuration parameters

Field	Description
Current SLID	Displays current SLID
Input new SLID	Enter new SLID
SLID Mode	Choose a SLID mode from the drop-down menu.

- 2 Configure the new SLID.
- 3 Click Save.
- 4 STOP. This procedure is complete.

Procedure 41 Device management

- 1 Select Maintain > Device Management from the top-level menu in the 10G PON Gateway window, as shown in Figure 62.

Figure 62 Device management window

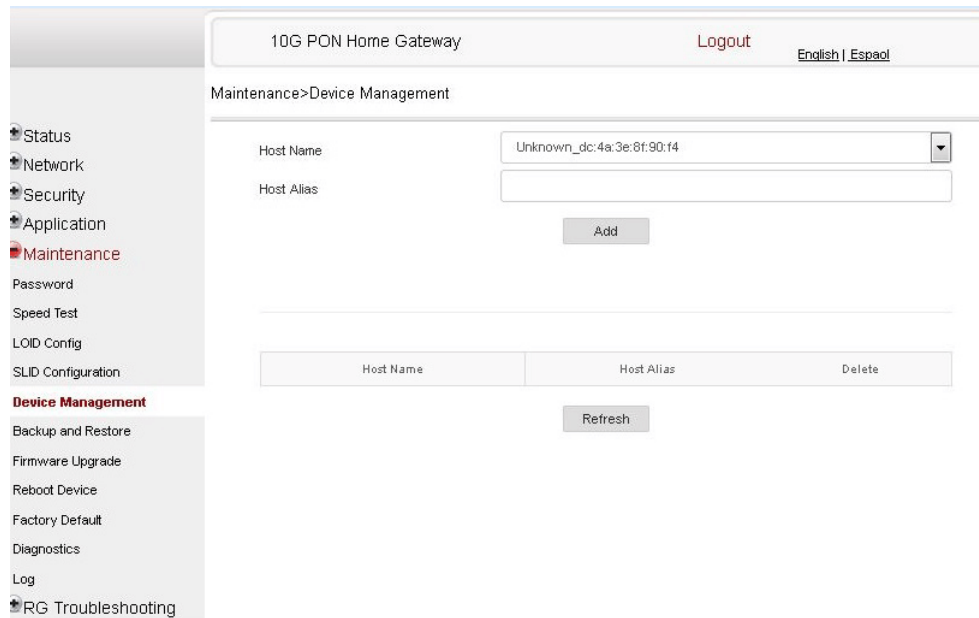

Table 46 describes the fields in the Device management window.

Table 46 Device management parameters

Field	Description
Host name	Choose a host from the drop-down menu
Alias	Enter an alias for the chosen host

- 2 Configure an alias for a specific host.
- 3 Click Add.
- 4 STOP. This procedure is complete.

Procedure 42 Backup and restore

- 1 Select Maintain > Backup and Restore from the top-level menu in the 10G PON Gateway window, as shown in Figure 63.

Figure 63 Backup and Restore window

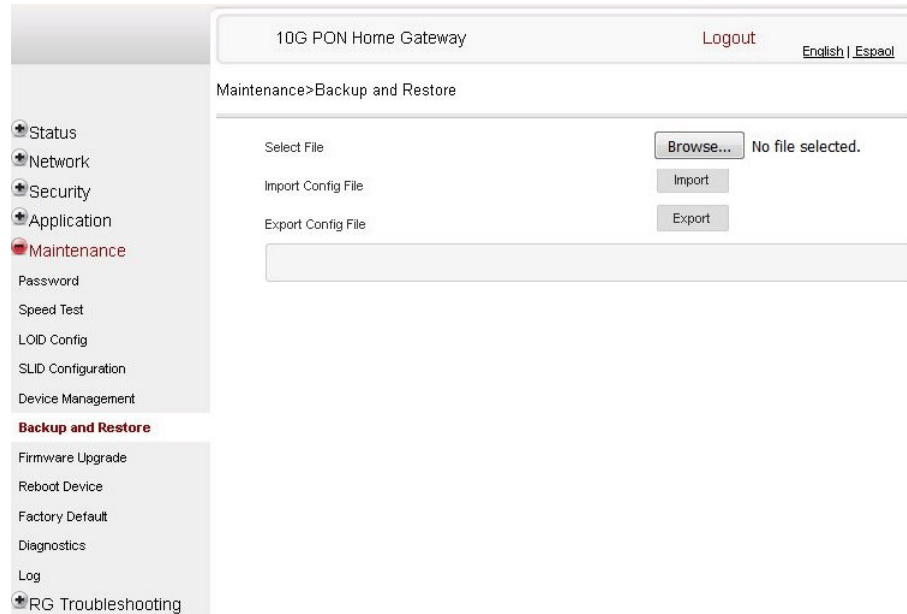

- 2 Click Select File and choose the backup file.
 - 3 Click Import Config File to restore the ONT to the saved backup or click Export Config File to export the current ONT configuration to the backup file.
 - 4 STOP. This procedure is complete.
-

Procedure 43 Upgrade firmware

- 1 Select Maintain > Firmware Upgrade from the top-level menu in the 10G PON Gateway window, as shown in Figure 64.

Figure 64 Firmware upgrade window

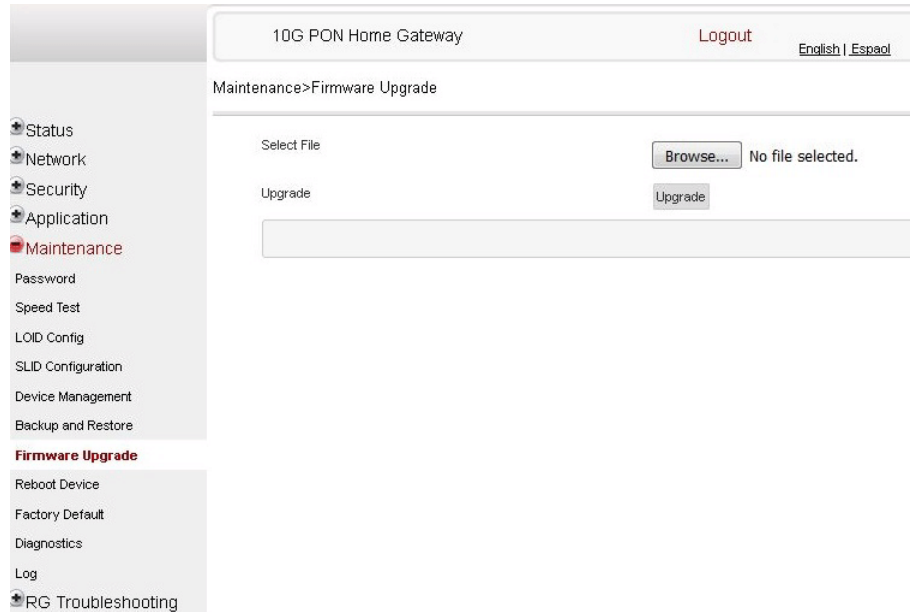

- 2 Click Select File and choose the firmware file.
- 3 Click Upgrade to upgrade the firmware.
- 4 STOP. This procedure is complete.

Procedure 44 Reboot ONT

- 1 Select **Maintain > Reboot Device** from the top-level menu in the 10G PON Gateway window, as shown in Figure 65.

Figure 65 Reboot window

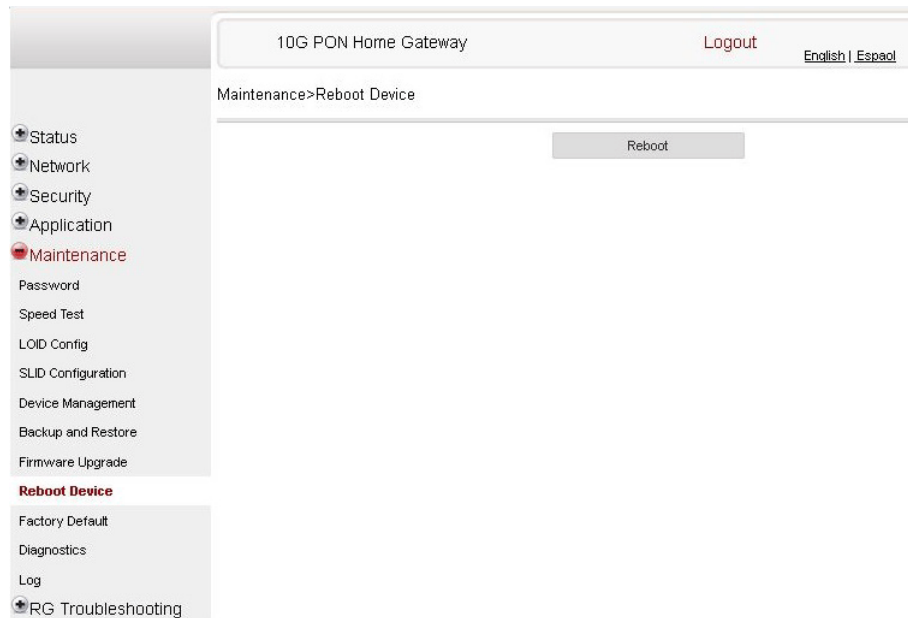

- 2 Click **Reboot** to reboot the ONT.
 - 3 **STOP.** This procedure is complete.
-

Procedure 45 Restore factory defaults

- 1 Select **Maintain > Factory Default** from the top-level menu in the 10G PON Gateway window, as shown in Figure 66.

Figure 66 Factory default window

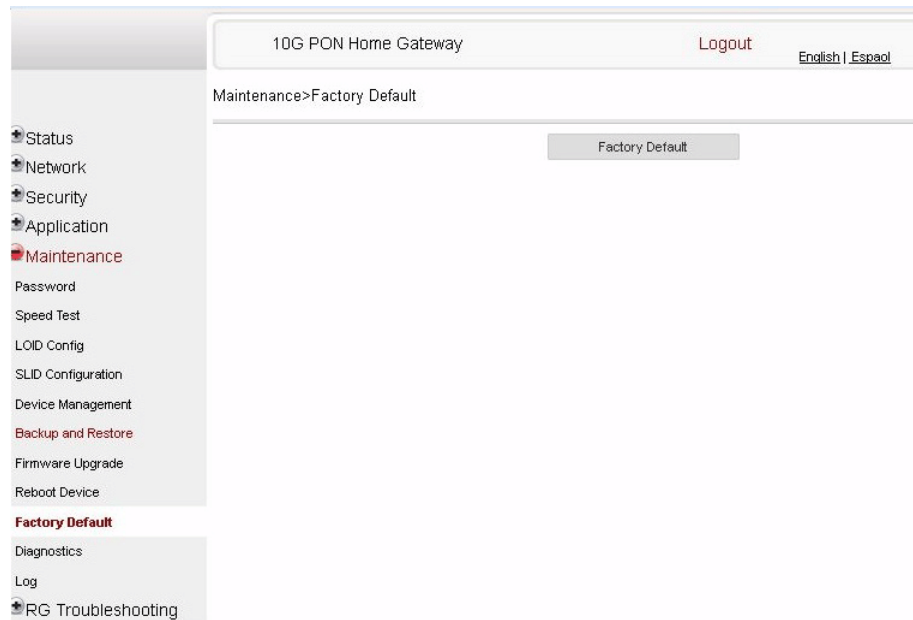

- 2 Click **Factory Default** to reset the ONT to its factory default settings.
 - 3 **STOP**. This procedure is complete.
-

Procedure 46 Diagnose WAN connections

- 1 Select **Maintain > Diagnose** from the top-level menu in the 10G PON Gateway window, as shown in Figure 67.

Figure 67 Diagnose window

10G PON Home Gateway Logout [English](#) | [Español](#)

Maintenance > Diagnostics

WAN Connect List: LAN/WAN Interface

IP or Domain Name:

Test: ping traceroute

Ping Try Times(1 ~ 1000):

Packet Length(64 ~ 1500):

Max no. of trace hops(1 ~ 255):

- 2 Choose a WAN connection to diagnose from the drop-down menu.
- 3 Enter the IP address or domain name.
- 4 Select the test type: ping, traceroute, or both.
- 5 Enter the number of ping attempts to perform (1 - 1000); the default is 4.
- 6 Enter a ping packet length (64-1024); the default is 64.
- 7 Enter the maximum number of trace hops (1-255); the default is 30.
- 8 Click **Start Test**. Results will be displayed at the bottom of the window.

- 9 Click Cancel to cancel the test.
- 10 STOP. This procedure is complete.

Procedure 47 View log files

- 1 Select Maintain > Log from the top-level menu in the 10G PON Gateway window, as shown in Figure 68.

Figure 68 Log window

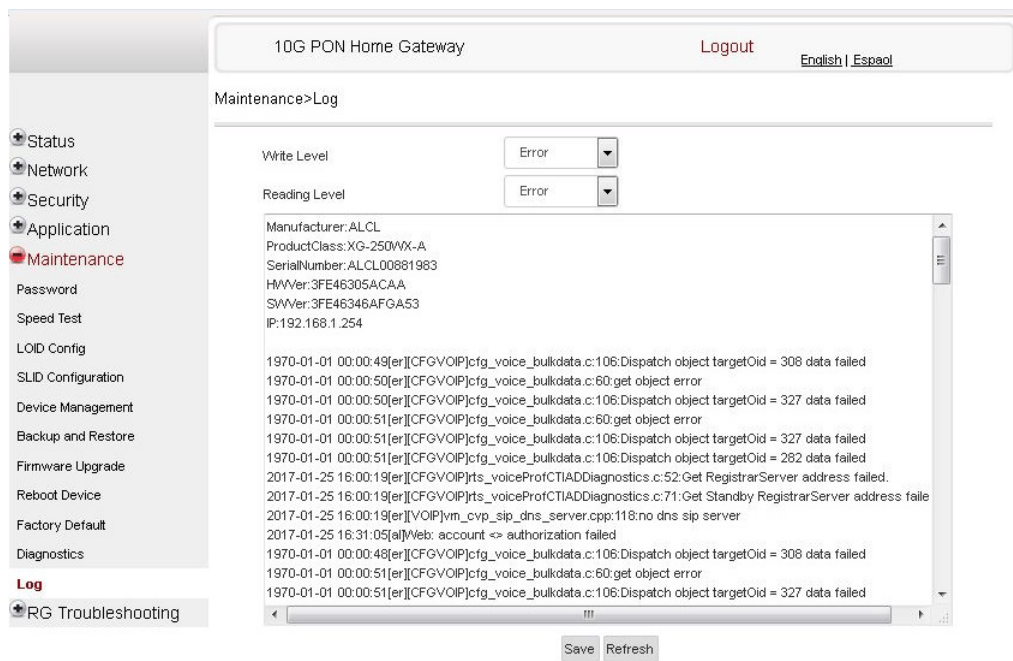

- 2 Choose a write level from the drop-down menu to determine which types of events are recorded in the log file:
 - Emergency
 - Alert
 - Critical
 - Error
 - Warning
 - Notice
 - Informational
 - Debug
 - 3 Choose a reading level from the drop-down menu to determine which types of events to display from the log file:
 - Emergency
 - Alert
 - Critical
 - Error
 - Warning
 - Notice
 - Informational
 - Debug
 - 4 The log file is displayed at the bottom of the window.
 - 5 STOP. This procedure is complete.
-

8.2.7 RG troubleshooting counters

The Troubleshooting Counters feature enables service providers and end users to monitor the performance of their broadband connection.

Tests are run to retrieve upstream and downstream throughput, latency, and DNS response time. The Troubleshooting Counters window also displays upstream and downstream packet loss and Internet status.

Note that port mirroring is not supported in Release 5.6.

Procedure 48 Retrieve Residential Gateway (RG) troubleshooting counters

- 1 Select RG Troubleshooting Counters from the left menu in the 10G PON Gateway window.

The RG Troubleshooting Counters window appears; see Figure 69.

Figure 69 RG Troubleshooting Counters window

The screenshot shows the '10G PON Home Gateway' interface. The left sidebar contains a menu with 'RG Troubleshooting' selected, and 'RG Troubleshoot Counters' highlighted. The main content area displays the following fields and controls:

- WAN Connection List:** A dropdown menu showing '1_INTERNET_R_VID_41'.
- US Throughput:** A button labeled 'US-SpeedTest'.
- DS Throughput:** A button labeled 'DS-SpeedTest'.
- US Packet Loss:** A text field.
- DS Packet Loss:** A text field.
- Internet Status:** A text field showing 'UP'.
- Latency:** A text input field and a button labeled 'LatencyTest'.
- DNS Response Time:** A text input field and a button labeled 'DNSResponseTest'.
- Port Mirror:** A section with four dropdown menus: 'Source Port' (set to 'WAN'), 'Destination Port' (set to 'LAN1'), 'Direction' (set to 'UP'), and 'Status' (set to 'Enable'). Below these is a 'Save' button.
- Table:** A table with four columns: 'Source Port', 'Destination Port', 'Direction', and 'Disable'.
- Refresh:** A button at the bottom of the window.

Table 47 describes the fields in the RG Troubleshooting Counters window.

Table 47 RG Troubleshooting Counters parameters

Field	Description
WAN Connection List	Select a WAN connection from the list

(1 of 2)

Field	Description
US Throughput	This test is used to determine the upstream throughput/speed Click US Speed Test to specify the time for the upstream test The default is weekly, performed at idle to a public server
DS Throughput	This test is used to determine the downstream throughput/speed Click DS Speed Test to specify the time for the downstream test The default is weekly, performed at idle to a public server
US Packet Loss	The number of upstream packages lost
DS Packet Loss	The number of downstream packages lost
Internet Status	Whether the broadband connections is active (UP) or not (DOWN)
Latency	This test is used to determine the lowest round-trip time in milliseconds by pinging the target server multiple times Click Latency Test to specify the time for the test The default is weekly, performed at idle to a public server
DNS Response Time	This test is used to determine the lowest round-trip time in milliseconds by sending a request to the target DNS server Click DNS Response Test to specify the time for the test The default is weekly, performed at idle to a public server

(2 of 2)

2 Configure the test times if desired.

3 Click Refresh to update the data.

4 STOP. This procedure is complete.

Customer document and product support

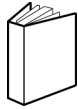

Customer documentation

[Customer Documentation Welcome Page](#)



Technical Support

[Customer Documentation Technical Support](#)



Documentation feedback

[Customer Documentation Feedback](#)

