NOKIA

Nokia RoofTop™ Wireless Router (R240/ R240A) Hardware Installation Guide (self-install)

COPYRIGHT

© 2000 Nokia Corporation. All rights reserved.
Rights reserved under the copyright laws of the United States.

RESTRICTED RIGHTS LEGEND

Use, duplication, or disclosure by the Government is subject to restrictions as set forth in subparagraph (c)(1)(ii) of the Rights in Technical Data and Computer Software clause at DFARS 252.227-7013.

TRADEMARKS

Nokia is a registered trademark of Nokia Corporation. Nokia RoofTop™ is a registered trademark of Nokia Networks. Other products mentioned in this document are trademarks or registered trademarks of their respective holders.

COMPLIANCE STATEMENTS

This hardware complies with the standards listed in this section.

Compliance in the United States

Emission Standards

UNINTENTIONAL EMISSIONS: FCC Part 15 CLASS B

INTENTIONAL EMISSIONS: FCC Part 15, Section 15.247

This equipment has been tested and found to comply with the limits for a Class B digital device, pursuant to Part 15 of the FCC rules. These limits are designed to provide reasonable protection against harmful interference in a residential installation. This equipment generates, uses, and can radiate radio frequency energy and, if not installed and used in accordance with the instructions, may cause harmful interference to radio communications. However, there is no guarantee that interference will not occur in a particular installation. If this equipment does cause harmful interference to radio or television reception which can be determined by turning the equipment off and on, the user is encouraged to try and correct the interference by one or more of the following measures:

- Reorient or locate the receiving antenna.
- Increase the separation between the equipment and receiver.
- Connect the equipment into an outlet on a circuit different from that to which the receiver is connected.
- Consult the dealer or an experienced radio/TV technician for help.

Any modifications made to the unit, unless expressly approved by Nokia could void the user's authority to operate the equipment.

FCC Rules and Regulations - Part 68

This equipment complies with Part 68 of the FCC Rules. The FCC Part 68 Label is located on the rear panel of the Network/Power Unit. This label contains, among other information, the FCC Registration Number and Ringer Equivalency Number (REN) for this equipment. You must, upon request, provide this information to your telephone company. The REN is useful to determine the quantity of devices you may connect to your telephone line and still have all those devices ring when your telephone number is called. In most but not all areas, the sum of the RENs of all devices connected to one line should not exceed five (5.0). To be certain of the number of devices you may connect to your line, as determined by the REN, you should contact your local telephone company to determine the maximum REN for your calling area.

Connection to the telephone network should be made by using standard modular telephone jacks, type RJ11. The plug and/or jacks used must comply with FCC Part 68 rules. If your telephone equipment causes harm to the telephone network, the telephone company may discontinue your service temporarily. If possible, they will notify you in advance, but if advance notice is not practical, you will be notified as soon as possible. You will be informed of your right to file a complaint with the FCC.

Your telephone company may make changes in its facilities, equipment, operations or procedures that could affect the proper functioning of your equipment. If they do, you will be notified in advance to give you an opportunity to maintain uninterrupted telephone service.

This equipment may not be used on coin service provided by the telephone company. Connection to party lines is subject to tariffs.

If trouble is experienced with this unit, for repair or warranty information, please contact customer service at the address and phone listed below. If the equipment is causing harm to the network, the telephone company may request that you disconnect the equipment until the problem is resolved.

DO NOT DISASSEMBLE THIS EQUIPMENT. It does not contain any user serviceable components.

Compliance in Canada

Canadian compliance (Industry Canada) When tested with at least one intended host: This digital apparatus does not exceed the Class B limits for radio noise emissions from digital apparatus set out in the interference-causing equipment entitled "Digital Apparatus", ICES-003 of the Canadian Department of Communications.

Cet appareil numérique respecte les limites bruits radioélectriques applicables aux appareils numériques de Class B prescrites dans la norme sur le matériel brouilleur: "Appareils Numériques", NMB-003 édictée par le Ministre Canadien des Communications.

Notice: The Industry Canada (IC) label identifies certified equipment. This certification means that the equipment meets telecommunications network protective, operational and safety requirements as prescribed in the appropriate Terminal Equipment Technical document(s). The department does not guarantee the equipment will operate to the user's satisfaction.

Before installing this equipment, users should ensure that it is permissible to be connected to the facilities of the local telecommunications company. The equipment must also be installed using an acceptable method of connection. The customer should be aware that compliance with the above conditions may not prevent degradation of service in some situations.

Repairs to certified equipment should be coordinated by a representative designated by the supplier. Any repairs or alterations

made by a user to this equipment, or equipment malfunctions, may give the telephone communications company cause to request the user to disconnect the equipment.

Notice: The Ringer Equivalent Number (REN) assigned to each terminal device provides an indication of the maximum number of terminals allowed to be connected to a telephone interface. The termination on an interface may consist of any combination of devices subject only to the requirement that the sum of the Ringer Equivalence Numbers of all the devices does not exceed 5.

REN: See the equipment for REN information.

DISCLAIMER:

TO THE INSTALLER: THE INSTRUCTIONS PROVIDED IN THIS GUIDE ARE PROVIDED "AS IS" WITHOUT WARRANTY OF ANY KIND EXPRESSED OR IMPLIED. NOKIA MAKES NO REPRESENTATIONS OR WARRANTIES, EXPRESS OR IMPLIED, INCLUDING BUT NOT LIMITED TO THE WARRANTIES OF MERCHANTABILITY OR FITNESS FOR A PARTICULAR PURPOSE OR INFRINGEMENT, INCLUDING ANY THIRD PARTY PATENTS, COPYRIGHTS, TRADEMARKS OR OTHER RIGHTS. THERE IS NO WARRANTY BY NOKIA THAT THE INSTRUCTIONS CONTAINED IN THE GUIDE WILL MEET YOUR REQUIREMENTS. THERE IS NO WARRANTY BY NOKIA THAT THE INSTRUCTIONS AND STATEMENTS CONTAINED IN THE GUIDE OR ITS CONTENT ARE TRUE, ACCURATE OR COMPLETE.

LIMITATION OF LIABILITY: TO THE MAXIMUM EXTENT PERMITTED BY APPLICABLE LAW, IN NO EVENT SHALL NOKIA, ITS EMPLOYEES OR AFFILIATES BE LIABLE FOR ANY LOST PROFITS, REVENUE, SALES, DATA, OR COSTS OF PROCUREMENT OF SUBSTITUTE GOODS OR SERVICES, PROPERTY DAMAGE, PERSONAL INJURY, INTERRUPTION OF BUSINESS, LOSS OF BUSINESS INFORMATION OR FOR ANY SPECIAL, DIRECT, INDIRECT, INCIDENTAL, ECONOMIC, COVER, PUNITIVE, SPECIAL OR CONSEQUENTIAL DAMAGES HOWEVER CAUSED, AND WHETHER ARISING UNDER CONTRACT, TORT, NEGLIGENCE, OR OTHER THEORY OF LIABILITY ARISING OUT OF THE USE OF OR INABILITY TO USE THE GUIDE, EVEN IF NOKIA OR AFFILIATES ARE ADVISED OF THE POSSIBILITY OF SUCH DAMAGES.

Contents

CHAPTER 1	<i>About this document</i>	9
	1.1 Introduction	9
	1.1.1 Task flowchart	9
CHAPTER 2	<i>Safety issues</i>	13
	2.1 Introduction	13
	2.2 Hazard warnings	14
	2.3 Regulatory safety requirements	15
CHAPTER 3	<i>Planning the installation</i>	17
	3.1 Main installation steps	17
	3.1.1 To find a location for the router	18
	3.1.2 To plan the Network/Power Unit location	19
	3.1.3 To plan the cable routing	19
	3.1.4 To plan the grounding	19
CHAPTER 4	<i>Outdoor installation</i>	21
	4.1 Introduction	21
	4.1.1 Components to be installed	21
	4.2 To install the router	22
	4.2.1 To prepare and install grounding	28
CHAPTER 5	<i>Routing the cable into the property</i>	31
	5.1 General guidelines on cable routing	31
CHAPTER 6	<i>Indoor installation</i>	33
	6.1 Introduction	33
	6.1.1 Components to be installed	33
	6.2 Network/ Power Unit (NPU)	34

Contents

6.3 To install the Network/ Power Unit	35
6.3.1 Connection options.....	38
6.3.2 Network	38
6.3.3 Direct personal computer connection.....	39
6.3.4 Home PNA connection.....	40
CHAPTER 7 <i>Configuring the end user PC</i>	41
7.1 Introduction.....	41
7.1.1 To configure the your personal computer.	42
CHAPTER 8 <i>Post installation testing</i>	43
8.1 Introduction.....	43
8.1.1 Functional testing.....	43
APPENDIX A Cables	45
APPENDIX B Technical Specifications	47

1.1 Introduction

This document explains the procedures necessary to install the Nokia Rooftop Wireless Router.



2.1 Introduction

It is important, when installing the Nokia Wireless Router, that the unit is not installed where it could be either damaged by its environment, or pose a hazard for the user. In this respect, when installing the unit be aware of the following Hazard Warnings and Regulatory Safety Requirements

2.2 Hazard warnings

- **Environment** - Do not place the Network Power Unit (NPU) in a very cold, dusty, wet or high humidity environment. The unit should be situated away from all heat sources such as radiators, heat registers, stoves, amplifiers and other heat producing appliances.
- **Fire or electric shock** - Do not expose the NPU to any type of moisture, including rain. Do not use or install near water-related environments such as sinks, bathtubs, laundry areas, spas, swimming pools, or in wet basements. Take care not to spill any liquids on the unit.
- Use extreme caution when installing antennas in areas with overhead power lines. Outdoor antennas and their supporting masts, guy wires, and cables are electrical conductors. Contact with high-voltage electrical wires can cause serious injury or death.
- Because antennas and wireless routers are elevated metal objects with connections to ground, they attract lightning. Attach a grounding wire to the antenna and router to provide a safe path to ground for lightning.
- Do not install the router near medical equipment or in a hospital or medical environment without ensuring that there will be no interference with such equipment.
- Persons with pacemakers should not go close to the router on the roof. If you have any reason to suspect that interference is taking place with a pacemaker, switch off the router immediately.
- **Co-location** - In certain situations, multiple wireless routers may be co-located on the rooftop of a residential subscriber. To comply with RF safety requirements, there must be a minimum distance of one meter (either horizontally or vertically, depending on the rooftop environment) between each wireless router. Wireless routers may not be co-located with or work in conjunction with other transmitting devices without professional installation.
- **RF exposure** - To comply with RF safety requirements, do not go closer than 20 cm of the antenna on the roof when the Network/Power Unit is plugged in.

3.1 Main installation steps

The complete wireless router installation consists of five basic steps:

1. The Nokia roofTop Wireless Router
2. The Multiwire connection (between the router and the Network/Power Unit)
3. The Network/ Power Unit
4. The grounding (where required)
5. The indoor connections between the Network/Power Unit and the computer(s) in the property.

When planning the installation the following needs to be considered:

- The hardware and tools required to complete the installation.
- Wireless router installation location.
- Multiwire routing between the router and the NPU.
- The power source location for the NPU.
- The routing path for the ethernet cabling.
- Antenna grounding and lightning arrestor requirements.

3.1.1 To find a location for the router

When planning the location of the router the highest point on the roof should be used to ensure a clear line of sight. Existing structures like chimneys, pipes, tv antenna poles etc. should be used for mounting the router. Only if there is no suitable mounting point, should a mounting pole be used.

Height of the antenna is often limited to physical limitations of the site. For example, an antenna mast can be placed on a rooftop or installed on an existing structure or tower. Avoid using a mast if at all possible, but be sure that the antenna clears the roof line.

It is acceptable to use the TV antenna pole already installed. If the TV antenna is used, be sure to loosen the antenna mounting, slide the TV antenna down the pole leaving sufficient room to mount the router at the top of the pole.

3.1.2 To plan the Network/Power Unit location

The Network/ Power Unit can only be physically located by being plugged into an AC outlet. When locating the AC outlet for the Network/ Power Unit consider:

- The route of the multiwire cabling
- The proximity of a telephone connection point (where applicable for HomePNA) or routing of the Ethernet cable

3.1.3 To plan the cable routing

- Avoid pipes, downspouts and possible areas which may abrade the cabling.

For further details see Chapter 6, Routing the cable into the property.

3.1.4 To plan the grounding

Test the existing grounding system at the property. Where the existing grounding is not acceptable, consider:

- Route of the grounding cable from the router, avoiding other pipes, down spouts etc
- Location for the grounding rod



4.1 Introduction

4.1.1 Components to be installed

The Outdoor portion of the Nokia RoofTop Wireless Router system comprises:

- Wireless router with integral antenna
- Grounding kit for router (if required)
- Router mounting hardware
- A shielded multiwire cable containing 7 twisted pairs of wires. This is used to connect the wireless router with the NPU. Nokia provides several different lengths of cable with D-Connectors already installed on the end of the cable.
- RF Cable adaptor, Nokia Code WR 46899A

4.2 To install the router

1. Mount the wireless router bracket to the mounting point, ensuring that the bracket is fixed securely.

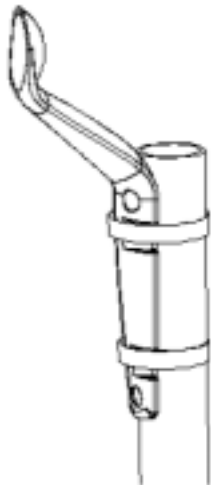

Router bracket fixed to mast

2. Attach the antenna by screwing it into the top of the wireless router. Carefully guide the antenna down onto the RF pin to prevent the pin being bent out of shape. Ensure secure connection, but do not overtighten.



Attach the omni-directional antenna

-
3. Connect the multiwire connection to the D-Connector in the bottom of the wireless router. Tighten the two screws on the connector and slide the rubber sleeve over the connections to prevent the ingress of water.

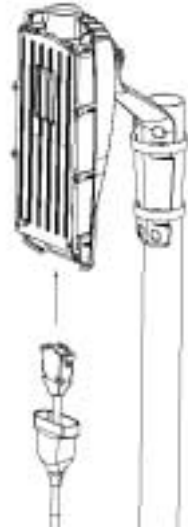

Attach multiwire connection and Ground wire

NOTE: Take care when tightening the D-Connector to the router. It is easy to damage the router casing if the screws are overtightened.

4. Using cable ties and/ or adhesive tape, secure the multiwire connection and ground wire (where used) to the mast. Take care to avoid placing strain on the connectors when securing the cables to the mast. Use ties/ tape about every two feet down the length of the mast. Always cover the cable ties with electrical tape to prevent excess pressure on the D-connector should the cable tie fail.
5. Attach mounting bracket to back of router. Ensure that the bolt fits correctly and is not cross threaded. There is no need to tighten the bolt, play is required to attach the router to the mast mounting bracket.

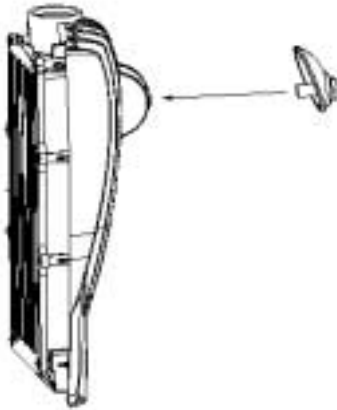

Attach mounting bracket to router

-
6. Attach the front panel of the wireless router.

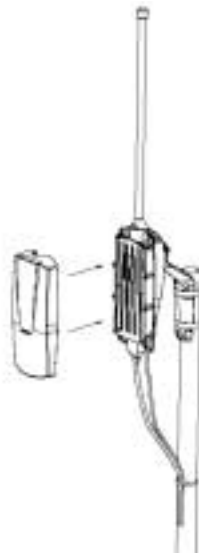

Attach front panel of wireless router

7. Slide the router and its bracket onto the router mount. Make sure that the router is mounted perfectly vertical on the mount, using a level as necessary, and tighten the bolt in the back of the router. Be careful not to overtighten the bolt. Overtightening of the bolt will strip the thread in the back of the aluminum casting of the wireless router.

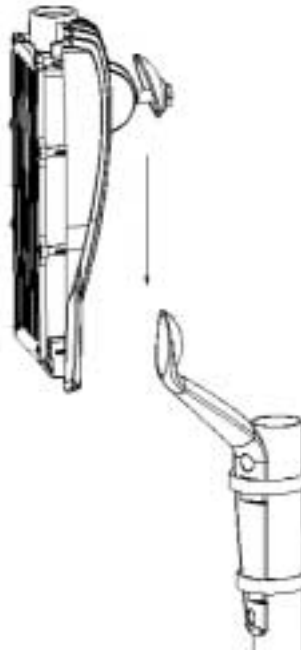

Slide the router mount onto the mast bracket

4.2.1 To prepare and install grounding

NOTE: Grounding is only installed where the existing grounding system is not sufficient for router grounding purposes.

Because antennas are elevated metal objects with connections to ground, they attract lightning.

Attaching an effective ground to the router provides a path for the lightning.

- 1.** Connect the grounding box connector marked “Surge” towards the antenna and the connector marked “Protected” to the Network/ Power Unit (NPU) end of the cabling.
- 2.** Protect the connections as previously described, using weatherproofing tape.
- 3.** Locate the lightning arrestor close to the point of entry to the home.
- 4.** Provide a good, very low resistance wire connection from the wireless router to the ground.
- 5.** Use #12 copper wire connected to the router grounding clamp and a ground rod next to the building.

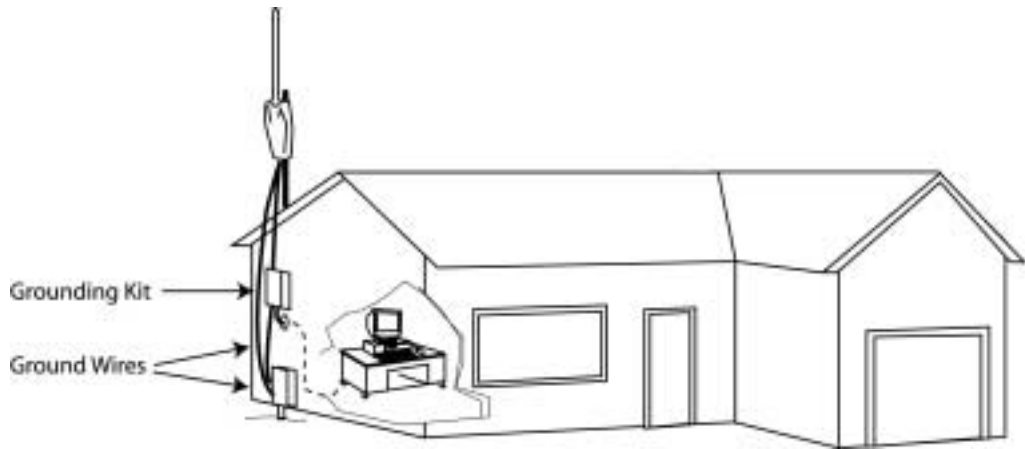

Grounding of router and NPU



5.1 General guidelines on cable routing

- Where possible, route the cables inside the wall/ roof spaces
- THINK where the cables are going to go! Avoid air ducts, water and gas pipes.
- Try to use existing entries into your home to avoid having to drill holes.
- Try to make the cable entry to the computer connections as close to the your PC as possible, using the shortest cable possible.
- Where wires have to be routed outside of the building, make sure that they are supported with cable clips at 18 to 24 inch intervals and are not unsightly. Make sure that there is a “drip loop” at the point of entry to prevent water ingress into the property. Seal any drilled holes using silicone sealant.



6.1 Introduction

6.1.1 Components to be installed

The Indoor portion of the Nokia Wireless Router System consists of:

- Network Power Unit (NPU)
- Ethernet or home PNA connection cable

6.2 Network/ Power Unit (NPU)

1. HomePNA 2.0 interface, a standard phone jack (RJ-11)
2. Ethernet interface, a standard 10/100 BaseT Ethernet jack (RJ-45)
3. Router outdoor unit connection: A multiwire cable from Router unit is connected to this.

The connector is a punch down connector inside the unit.



6.3 To install the Network/ Power Unit

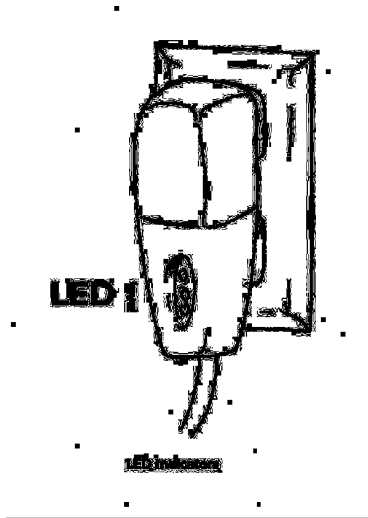

1. Trim back the multiwire cable insulation taking care not to cut any of the smaller wires in the cable.
2. Remove the Network/Power Unit from its' packaging and loosen the strain relief (the unit is already disassembled).
3. Place the cable through the strain relief and slot the appropriate wire into the appropriate slot in the connection. Using the punch down tool, fix the wire into the Network/ Power Unit.
4. When all wires are connected securely, reconnect the cable strain relief in the unit to prevent the multiwire cable from being pulled out of the unit.
5. Replace the Network/Power Unit cover and replace the screws. Do not overtighten the screws.
6. Plug the Network/Power Unit into the wall AC outlet. The LEDs on the unit should flash three times to indicate that the unit is connected to the router.

-
7. Connect the ethernet cable from the Network/ Power Unit to the PC or home PNA adapter or network hub.

NOTE: Shielded ethernet cables must be used on all installations.

The LEDs indicate the following information:

LED	Description
Power/ LAN	<p><u>Solid On</u> Power on, but no ethernet packets seen</p> <p><u>Slow Flash</u> Waiting for the router to complete boot cycle</p> <p><u>Intermittent Flash</u> Off during packet transmit or receive. Otherwise ON</p> <p><u>Off</u> No power or the router is not functioning (IROS is off)</p>

LED	Description
<p>Anchor</p>	<p><u>Solid On</u> The link to the neighbor in the path to the AirHead has an uplink and downlink speed of 2Mb and the path to the AirHead is less than, or equal to 3 hops</p> <p><u>Slow Flash</u> The link to the neighbor in the path to the AirHead has an uplink and downlink speed of 1Mb and the path to the AirHead is less than, or equal to 3 hops</p> <p><u>Fast Flash</u> More than 3 hops to the AirHead or The unit has neighbors but there is no path to the AirHead</p> <p><u>Off</u> The router has no neighbors</p>
<p>Network</p>	<p><u>Solid On</u> More than, or equal to 2 independent neighbors, with at least one 2Mbps path to the AirHead and the path to the AirHead is less than or equal to 3 hops</p> <p><u>Slow Flash</u> Greater than, or equal to 2 independent neighbors with a 1 Mbps path to the Air-Head and the AirHead is less than, or equal to 3 Hops</p> <p><u>Fast Flash</u> The unit has 1 neighbor with a 2 Mbps path to the AirHead and the AirHead is less than, or equal to 3 Hops</p> <p><u>Off</u> None of the above</p>

6.3.1 Connection options

There are three ways to connect the Wireless Router to the computer system:

- Network Hub Connection, using 10/ 100bT ethernet interface.
- Direct Personal Computer Connection, using 10/ 100bT ethernet crossover cable.
- Home PNA Connection.

The Router automatically activates the ethernet or Home PNA, depending upon which connector is used. If the cable is connected to both connectors, the ethernet port is activated.

All these options are described in more detail below.

6.3.2 Network

Use a standard Ethernet Cable with an RJ45 connector at the Wireless Router and the appropriate connector at the LAN Ethernet connection.

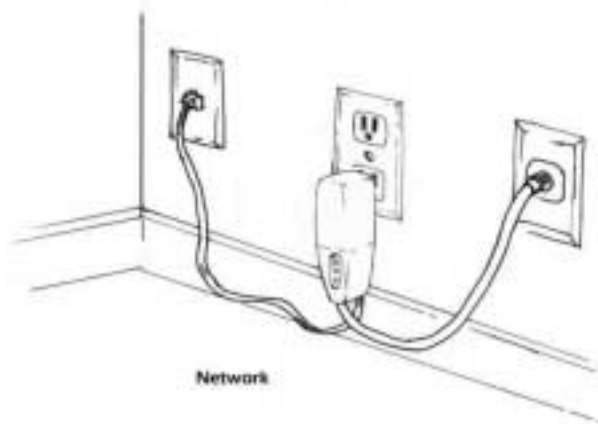

Network Connection

6.3.3 Direct personal computer connection

Connect an Ethernet crossover cable between the Network Interface and Power Supply Unit and the Personal Computer Ethernet connection. Use an RJ45 connector at the Network/ Power Unit and the appropriate connector for the Personal Computer Ethernet connection. See appendix for wiring diagram for crossover cable.

Connect the Network/ Power Unit, computer and LAN as shown in the following diagram.

Use one crossover cable whenever a network hub is not being used and always use it at the PC.

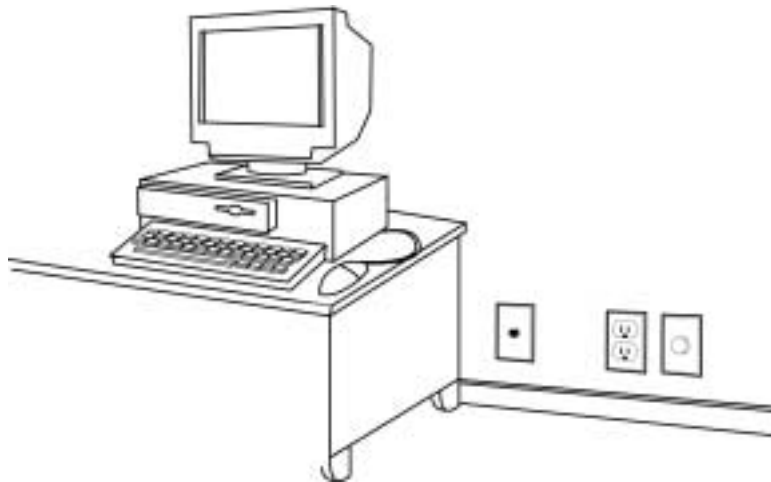

Direct PC connection

NOTE: Changing the Ethernet configuration from a LAN connection to a direct PC connection requires changing from a standard Ethernet cable to a crossover cable.

6.3.4 Home PNA connection

- Connect the phone cable between a Network/ Power Unit HomePNA connection and RJ11 phone jack or directly to the PC-HomePNA adapter.
- Connect PC to adapter according to manufacturers instructions.

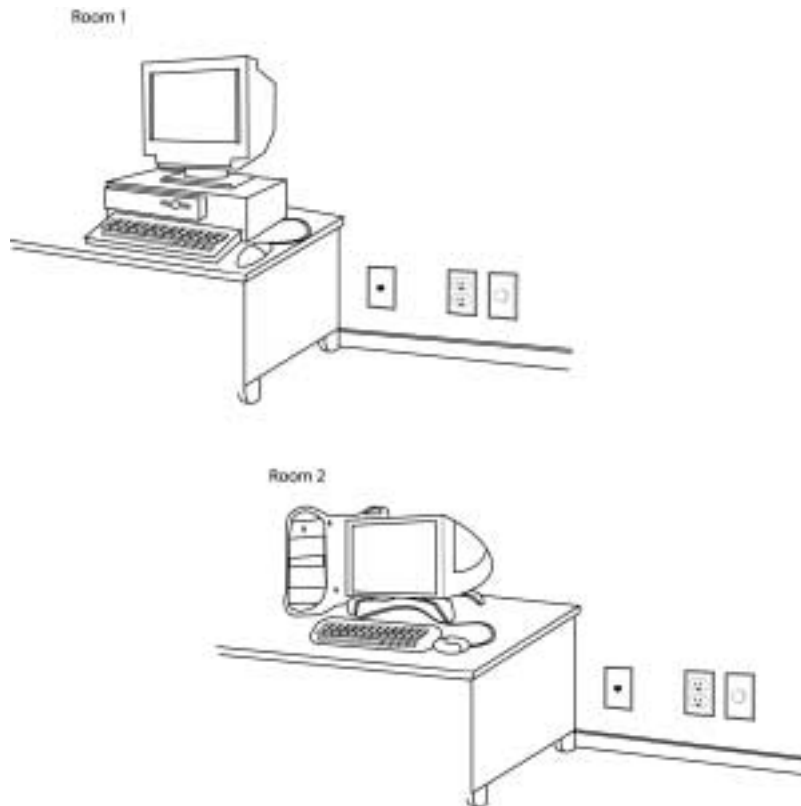

7.1 Introduction

After the router installation is complete, your PC needs to be configured for use with the Nokia Wireless Router system. The ISP provides all the information required prior to installation.

7.1.1 To configure the your personal computer

This section covers the Microsoft WindowsTM operating system.

- 1.** Check that the PC has a network interface card (NIC).

If the PC does not have a NIC, install it.

- 2.** Define the TCP/IP Properties. In the IP Address field, either select the "Obtain IP Address Automatically" or enter the IP Address and Subnet Mask in accordance with information provided by the ISP.
- 3.** In the Default Gateway field, enter the IP address of the default gateway, provided by the ISP.

8.1 Introduction

It is necessary to ensure that the system is working correctly after full wireless router, Network/ Power Unit installations and PC configuration are complete.

To carry out the test, follow the procedure shown below.

8.1.1 Functional testing

Ensure that the router functions correctly by carrying out the following:

1. Ensure that the NPU is inserted properly into the AC-outlet. The LEDs flash three times to indicate that the router is functioning correctly.
2. Turn on your PC. Wait for 3-5 minutes to allow the router to anchor to the network.
3. Check that the LEDs indicate an active internet connection (according to Chapter 6 - Indoor installation).

-
4. Open a web-browser and browse a few Internet pages to ensure that the system downloads web sites.

NOTE: AOL customers will need to use dial-up connections for the AOL browser to perform correctly. The router supports only Netscape and Internet Explorer browsers.

5. Check the data speed by placing a “throughput test” to www.2wire.com. Generally, speeds of 200kb are acceptable.
6. Where there are problems with download or speed of connection, check the installation first. If this does not solve the problem, then contact the ISP.

Ethernet crossover cable

The wiring for an Ethernet Crossover cable for 10Base-T is as follows:

RJ45 Plug

Pin 1 (Tx+) to Pin 3 (Rx+)

Pin 2 (Tx-) to Pin 6 (Rx-)

Pin 3 (Rx+) to Pin 1 (Tx+)

Pin 6 (Rx-) to Pin 2 (Tx-)



Technical Specifications

This appendix describes technical specifications for Nokia RoofTop™ Wireless Router Models R240 & 240A Outdoor-Mounted Unit.

Data Capacity per Cell	12 Mbps (6x2 Mbps per channel)
AirHeads (master routers that are connected to the wired Internet via backhaul) per Cell	Up to 6
Routers per Cell	Up to 240
Routers per AirHead	Up to 40
Antenna Type	8 dBi Omnidirectional (integrated)
Link Range (typical)	
1 Mbps Data Rate	1.75 Miles
2 Mbps Data Rate	0.50 Miles

Radio/ Modem Specifications	
Frequency Band (GHz)	2.4000 - 2.4835
Radio Type	Frequency Hopping Spread Spectrum
Modulation	2 and 4 level GF SK
Transmit Power (typical)	12 dBm - 27.5 dBm (Dynamically adjusts in 1dB steps)
Receiver Sensitivity(10⁻⁵ BER)	
1Mbps Data Rate	- 82 dBm (typical)
2 Mbps Data Rate	-72 dBm (typical)
Interfaces and Connectors	
Ethernet	10/100 Base -TX, autosensing, RJ-45
Phoneline Networking	Home PNA 2.0/ 1.0, RJ-11
Router Environment	
Operational Temperature	- 40° C to 55° C (-40° to 131° F)
Relative Humidity	100%
Weight	
Router	3.3 lbs (including antenna and mount)
Dimensions	
Router	4"W x 2 ³ / ₈ "D x 8 ¹ / ₄ "H
NPU	1 ³ / ₄ "W x 2 ³ / ₄ "D x 5 ¹ / ₂ "H
Antenna (8dBi)	21 ¹ / ₂ "H x ³ / ₄ " Diameter
Power Consumption	16 Watts @ 120 VAC
Management	Nokia Wireless Router Manager, SNMP MIB II, Telnet

Internet Protocols	IP, TCP, UDP, ICMP, RIPv1, RIPv2, SNMP, TFTP, IGMP, ARP, Proxy-ARP, Telnet, DHCP Relay, DHCP Server, NAT.
Agency Compliance	FCC Class B, FCC CFR 47 Part 15, FCC Part 68 ICES-003, RSS-210, CS-03

