



FastMile Rel.17.10

# **FastMile Home Outdoor Modem User Manual**

DN09218237

Issue 03 Draft 28.11.2017

# Disclaimer

The information in this document applies solely to the hardware/software product ("Product") specified herein, and only as specified herein. Reference to "Nokia" later in this document shall mean the respective company within Nokia Group of Companies with whom you have entered into the Agreement (as defined below).

This document is intended for use by Nokia's customers ("You") only, and it may not be used except for the purposes defined in the agreement between You and Nokia ("Agreement") under which this document is distributed. No part of this document may be used, copied, reproduced, modified or transmitted in any form or means without the prior written permission of Nokia. If You have not entered into an Agreement applicable to the Product, or if that Agreement has expired or has been terminated, You may not use this document in any manner and You are obliged to return it to Nokia and destroy or delete any copies thereof.

The document has been prepared to be used by professional and properly trained personnel, and You assume full responsibility when using it. Nokia welcomes your comments as part of the process of continuous development and improvement of the documentation.

This document and its contents are provided as a convenience to You. Any information or statements concerning the suitability, capacity, fitness for purpose or performance of the Product are given solely on an "as is" and "as available" basis in this document, and Nokia reserves the right to change any such information and statements without notice. Nokia has made all reasonable efforts to ensure that the content of this document is adequate and free of material errors and omissions, and Nokia will correct errors that You identify in this document. Nokia's total liability for any errors in the document is strictly limited to the correction of such error(s). Nokia does not warrant that the use of the software in the Product will be uninterrupted or error-free.

NO WARRANTY OF ANY KIND, EITHER EXPRESS OR IMPLIED, INCLUDING BUT NOT LIMITED TO ANY WARRANTY OF AVAILABILITY, ACCURACY, RELIABILITY, TITLE, NON-INFRINGEMENT, MERCHANTABILITY OR FITNESS FOR A PARTICULAR PURPOSE, IS MADE IN RELATION TO THE CONTENT OF THIS DOCUMENT. IN NO EVENT WILL NOKIA BE LIABLE FOR ANY DAMAGES, INCLUDING BUT NOT LIMITED TO SPECIAL, DIRECT, INDIRECT, INCIDENTAL OR CONSEQUENTIAL OR ANY LOSSES, SUCH AS BUT NOT LIMITED TO LOSS OF PROFIT, REVENUE, BUSINESS INTERRUPTION, BUSINESS OPPORTUNITY OR DATA THAT MAY ARISE FROM THE USE OF THIS DOCUMENT OR THE INFORMATION IN IT, EVEN IN THE CASE OF ERRORS IN OR OMISSIONS FROM THIS DOCUMENT OR ITS CONTENT.

This document is Nokia proprietary and confidential information, which may not be distributed or disclosed to any third parties without the prior written consent of Nokia.

Nokia is a registered trademark of Nokia Corporation. Other product names mentioned in this document may be trademarks of their respective owners.

Copyright © 2017 Nokia. All rights reserved.



## Important Notice on Product Safety

This product may present safety risks due to laser, electricity, heat, and other sources of danger.

Only trained and qualified personnel may install, operate, maintain or otherwise handle this product and only after having carefully read the safety information applicable to this product.

The safety information is provided in the Safety Information section in the "Legal, Safety and Environmental Information" part of this document or documentation set.

Nokia is continually striving to reduce the adverse environmental effects of its products and services. We would like to encourage you as our customers and users to join us in working towards a cleaner, safer environment. Please recycle product packaging and follow the recommendations for power use and proper disposal of our products and their components.

If you should have questions regarding our Environmental Policy or any of the environmental services we offer, please contact us at Nokia for any additional information.

# Table of contents

<b>1</b>	<b>Introduction .....</b>	<b>9</b>
1.1	Scope.....	9
1.2	Who Should Read this Manual .....	9
1.3	How this manual is organized.....	9
1.4	Acronyms.....	9
<b>2</b>	<b>Home Outdoor Modem Overview .....</b>	<b>10</b>
2.1	Product Overview .....	10
2.2	Functional Overview .....	10
2.3	Variants Overview.....	10
2.3.1	Variants .....	10
2.4	Key Characteristics.....	11
2.4.1	LTE.....	11
2.4.2	Ethernet.....	11
2.4.3	Power supply.....	11
2.4.4	TR-069 .....	11
2.5	Interface/Ports .....	11
2.6	LED Status.....	12
2.7	Power Source .....	13
2.8	Performance .....	13
2.8.1	Throughput.....	13
2.8.2	Power Consumption .....	13
2.9	Certifications .....	14
<b>3</b>	<b>Installation Procedure .....</b>	<b>15</b>
3.1	Safety Information.....	15
3.2	Package Contents .....	15
3.3	Home Outdoor Modem Installation Prerequisites.....	15
3.3.1	Lightning protection.....	16

3.4	Home Outdoor Modem installation .....	16
3.4.1	Selecting the Home Outdoor Modem mounting location using Installation App .....	16
3.4.2	Mounting Instructions .....	24
3.4.3	Connectivity and power up sequence .....	32
3.4.4	Managing Home Outdoor Modem through Management app .....	35
<b>4</b>	<b>Troubleshooting.....</b>	<b>37</b>
4.1	Common Problems during Installation and startup Phase .....	37
4.1.1	Home Outdoor Modem is not registered. ....	37
4.1.2	Home Outdoor Modem registration fails at Controller.....	37
4.1.3	Home Outdoor Modem is registered to a wrong BS/Cell .....	37
4.1.4	Home Outdoor Modem installation application cannot connect to the Controller.....	38
4.1.5	Home Outdoor Modem cannot form the LTE connection by using the narrow-beam. ....	39
4.1.6	Cable between Home Outdoor Modem and Home Router not properly connected .....	41
4.1.7	SIM is not inserted.....	41
4.1.8	Invalid PIN .....	42
4.1.9	Home Outdoor Modem is not able to attach to LTE Network due to Incorrect APN.....	42
4.2	Common Problems during Execution Phase.....	43
4.2.1	Home Outdoor Modem Provisioning is not successful after reboot/factory reset .....	43
4.2.2	Home Outdoor Modem firmware upgrade to latest build failed .....	43
4.2.3	Home Outdoor Modem is not able to communicate with Controller after firmware upgrade 44	
4.2.4	Home Outdoor Modem detached from network.....	44
<b>5</b>	<b>Appendix A: Factory Settings .....</b>	<b>45</b>
<b>6</b>	<b>Appendix B Specifications .....</b>	<b>46</b>
<b>7</b>	<b>Appendix D FCC Compliance Statement.....</b>	<b>47</b>

## List of figures

Figure 1	Front and Back view of Home Outdoor Modem.....	10
Figure 2	Interfaces/Ports at Home Outdoor Modem - 1.....	12
Figure 3	Interfaces/Ports at Home Outdoor Modem - 2.....	12
Figure 4	Welcome Screen.....	17
Figure 5	Need Location.....	17
Figure 6	Phone Calibration.....	18
Figure 7	Finding Location.....	19
Figure 8	Find QR code.....	19
Figure 9	Scan the QR code.....	20
Figure 10	Set FastMile Controller Address.....	20
Figure 11	Check the contents.....	21
Figure 12	Insert the SIM.....	22
Figure 13	Finding nearest tower.....	23
Figure 14	Check Mount Type.....	24
Figure 15	Wall Selection.....	25
Figure 16	Setting Direction.....	25
Figure 17	Bottom view of Wall Mounting Anchor.....	26
Figure 18	Install Mount.....	26
Figure 19	Earth connection with Wall-mount and Poll-mount Configuration.....	27
Figure 20	Connect cable.....	27
Figure 21	Tilt Home Outdoor Modem.....	28
Figure 22	Lock Home Outdoor Modem.....	28
Figure 23	Install the Pole.....	29
Figure 24	Pole Mount Option.....	29
Figure 25	Bottom view of Pole Mount.....	30
Figure 26	Setting Direction.....	30
Figure 27	Tilt the Home Outdoor Modem.....	31

---

Figure 28	Lock Home Outdoor Modem .....	31
Figure 29	Power sequence of Home Outdoor Modem through Home Router .....	32
Figure 30	Ethernet Adapter Assembly .....	32
Figure 31	Connect Cable.....	33
Figure 32	Plug in Home Router .....	34
Figure 33	Testing Connection .....	34
Figure 34	Software Update Available .....	35
Figure 35	Install Updates.....	36
Figure 36	Connection .....	36
Figure 37	Cell re-assignment during Home Outdoor Modem Installation Procedure .....	40

## List of tables

Table 1	Manual contents .....	9
Table 2	Acronyms .....	9
Table 3	Interfaces/ports of Home Outdoor Modem .....	12
Table 4	LED Status .....	13
Table 5	LTE throughput.....	13
Table 6	Home Outdoor Modem Certifications.....	14
Table 7	Package contents of Home Outdoor Modem.....	15
Table 8	Factory settings .....	45
Table 9	Specifications .....	46

## Summary of changes

Changes between document issues are cumulative. Therefore, the latest document issue contains all changes made to previous issues.

### **Changes between issues 01 and 02**

Valid for FastMile 17.6. Updated the supported bands in section 2.3.2 LTE

Key Characteristics.

### **Changes between issues 02 and 03**

Valid for FastMile 17.10. Several minor changes.



# 1 Introduction

## 1.1 Scope

The purpose of this document is to primarily provide installation requirements and procedures for Nokia FastMile Home Outdoor Modem.

## 1.2 Who Should Read this Manual

This document is intended for persons installing and troubleshooting the equipment.

## 1.3 How this manual is organized

#	Chapter	Contents
1	Introduction	Introduces the FastMile Home Outdoor Modem (ODU); defines the purpose, scope, and intended audience of this document; explains how information is organized in this document.
2	Home Outdoor Modem Overview	This chapter presents brief overview of Home Outdoor Modem.
3	Installation Procedure	This chapter presents detailed installation steps and startup procedure for Home Outdoor Modem
4	Troubleshooting	This chapter lists down common problems faced during various phases. It also contains their resolutions.

Table 1 Manual contents

## 1.4 Acronyms

The acronyms below are fundamental to the information provided in this guide.

Acronym	Expanded
ACS	Auto Configuration Server
CPE	Customer Premises Equipment
IDU	Indoor Unit of CPE (same as Home Router)
NTE	Network Termination Equipment (same as Home Outdoor Modem, ODU)
ODU	Outdoor Unit of CPE (same as Home Outdoor Modem, NTE)
PoS	Point of sales
PoSApp	Point of sales Application
LTE	Long Term Evolution
LTTH	LTE to the home
LTTH-C	FastMile Controller
SIM	Subscriber Identity module

Table 2 Acronyms

---

## 2 Home Outdoor Modem Overview

This chapter provides an overview of Home Outdoor Modem.

### 2.1 Product Overview

Home Outdoor Modem is the Outdoor Unit of Nokia FastMile solution, the purpose of which is to provide the last mile broadband connection using LTE technology.



**Figure 1** Front and Back view of Home Outdoor Modem

The Home Outdoor Modem includes high-gain beam forming antenna and LTE modem providing the LTE broadband access to the network. Home Outdoor Modem is capable of sustaining outdoor environmental conditions.

### 2.2 Functional Overview

The Nokia FastMile Home Outdoor Modem wireless broadband access to meet end users' networking needs. The FastMile Home Outdoor Modem lets operators use LTE to offer fixed wireless broadband

The FastMile Home Outdoor Modem is easy to install and user-friendly to operate. The smart phone installation application makes sure the modem is deployed in the optimal location.

The FastMile Home Outdoor Modem supports remote management capability, allowing management and health monitoring of the devices from FastMile Controller management system.

### 2.3 Variants Overview

#### 2.3.1 Variants model number

FMHOM0007A	Band 41 with Arctic operating temperature range (-30°C to 65°C)
FMHOM0007	Band 41 with Standard operating temperature range (-20°C to 65°C)

Above variants retain a common FCCID: 2AL7J-FMHOMN0041 for Band 41 operation

## Key Characteristics

### 2.3.2 LTE

LTE 3GPP Release 9 Compliant, UE Category 4

Transmit avg power: Max +23dBm +/-2.7dB

FastMile 17.10: Supported Band 41

#### Antenna Characteristics:

3x3 dual polarized antenna array

Electronical beam steering +/- 45° horizontally

14.5 dBi peak antenna gain

### 2.3.3 Ethernet

Supports 1GbE WAN Interface

Supports IEEE802.3 1000BASE-T

Supports CAT5e/6 unshielded twisted pair cable

Supports IEEE802.3az Energy efficient Ethernet

### 2.3.4 Power supply

The Home Outdoor Modem is powered via PoE from the Home Router or PoE injector.

WAN Port supports PoE+ as per IEEE802.3 at type-2

### 2.3.5 TR-069

Supports device management using TR-069 Amendment 5.

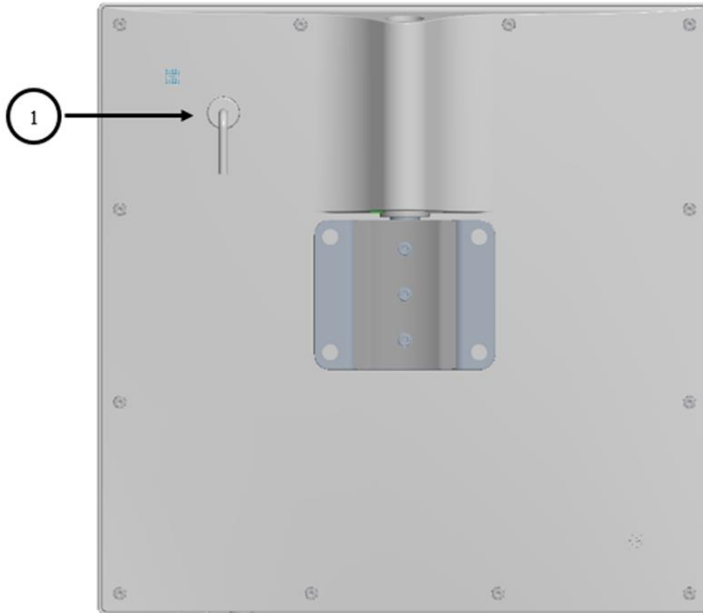
Supports configuration management, diagnostics and monitoring at Home Outdoor Modem.

## 2.4 Interface/Ports

#	Interface/port
1	1Gbps Ethernet port (PoE+ PD WAN)

2	SIM Slot (Nano/4FF SIM)
3	Reset Button
4	LED Indicator

**Table 3 Interfaces/ports of Home Outdoor Modem**



**Figure 2 Interfaces/Ports at Home Outdoor Modem - 1**



**Figure 3 Interfaces/Ports at Home Outdoor Modem - 2**

## 2.5 LED Status

#	Stage	LED	Blink rate
1	Power-On, Early Boot	WHITE(Non-Flashing)	No Blink
2	Successful Start	GREEN(Non-Flashing)	No Blink
3	Issue at Home Outdoor Modem (resulting to no service)	Flashing ORANGE	2Hz
4	SW update is available	Flashing Green	0.5Hz

5	Pressing 'Reset to Factory Defaults' button (or) Reset done programmatically	Flashing ORANGE for 1 Sec	2Hz
---	--	---------------------------	-----

Table 4 LED Status

## 2.6 Power Source

The Home Router (IDU) and Home Outdoor Modem (ODU) are connected together with a CAT 5e/ 6 that provides power from the Home Router to the Home Outdoor Modem through PoE+.

## 2.7 Performance

### 2.7.1 Throughput

#### 2.7.1.1 LTE

Use case	UDP UL	UDP DL	UDP Bi-dir (UL/DL)	TCP UL	TCP DL	TCP Bi-dir (UL/DL)
Throughput achieved (Mbps)	46	145	46/145	45.5	142	45.5/ 142

Table 5 LTE throughput

- Data rates can have a margin of 2-3 % error.
- Packet Length used is 1460 B in case of UDP, Window is 128k in case of TCP.
- The data rates are for IPv4 cases.

#### 2.7.1.2 Ethernet

Ethernet 1000BASE-T, throughput as per standard is max 1000Mbps. The Ethernet link gets negotiated at 1000Mbps when Home Router is connected to it. The end to end throughput achieved is 145/46 Mbps (restricted by LTE Throughput).

### 2.7.2 Power Consumption

Power consumption at full throughput: ~2.2Watts

Power consumption at Low LTE Signal Level: ~4.5Watts

---

## 2.8 Certification details

Certification	Remarks
FCC certification on TDD Band 41	For US operation

**Table 6** Home Outdoor Modem Certification

## 3 Installation Procedure

This chapter describes the pre-requisites for Home Outdoor Modem Installation. The chapter also guides us with the step by step installation procedure along with the dependencies on each step.

### 3.1 Safety Information

- Professional installation is recommended for Home Outdoor Modem. If the user plans to install the Home Outdoor Modem himself, safety instructions should be take care of.
- Use only FastMile Home Router or Nokia approved PoE Injectors for powering the Home Outdoor Modem.
- Do not POWER ON the Home Outdoor Modem before assembling the entire setup.
- Maintain at least 50 cm distance from the front face of the Home Outdoor Modem while the system is operating.
- Install at a minimum height of 2.5 meters from the ground plane
- WARNING: Lightning Danger: Since cables from external environment may connect to the system and they are exposed to lightning, do not work on equipment or cables during periods of lightning activity.

### 3.2 Package Contents

Sales Item No	Item	Quantity
1	Home Outdoor Modem Unit	1
2	Ethernet Adapter	1
3	Wall Mounting Anchor	1
4	Pole Mounting Anchor (Optional)	1

**Table 7** Package contents of Home Outdoor Modem

Note: If one or more item(s) mentioned above is missing or damaged, please contact customer support.

### 3.3 Home Outdoor Modem Installation Prerequisites

- Installation person should have the knowledge on installing the Unit.
- Valid SIM needs to be inserted in the Home Outdoor Modem before mounting to the pole or wall.
- All the devices should be available and registered on operator's Point of Sales location.
- Mechanical tools are required (not included) for mounting the Home Outdoor Modem.

- 
- Mobile apps requirements: iPhone or Android phones with hardware compass
    - iPhone iOS needs to be 9 or above
    - Android OS needs to be 5.0 Lollipop or above.

### 3.3.1 Lightning protection

- If you are installing the Home Outdoor Modem above roof level, check that lightning rods are above the planned install location.
- If outside cable length is less than 10 meters, no protection is required. If there is long outside cabling, we recommend installing PoE+ capable surge protectors.
- Use only properly earthed wall socket for powering the Home Router power adaptor (or PoE+ injector).

## 3.4 Home Outdoor Modem installation

The FastMile Home Outdoor Modem can be installed by using the Mobile Installation App and following the below mentioned steps.

### 3.4.1 Selecting the Home Outdoor Modem mounting location using Installation App

Mobile Installation App helps to select the best wall/pole for mounting the Home Outdoor Modem. Mobile Installation App can also be used to perform the initial Cell selection for Home Outdoor Modem installation.

Follow the below ordered steps for Home Outdoor Modem installation using Mobile Installation App:

#### Step 1:

Open Installation App on your phone. To run this App, the phone should be connected to internet. A Welcome screen will appear.



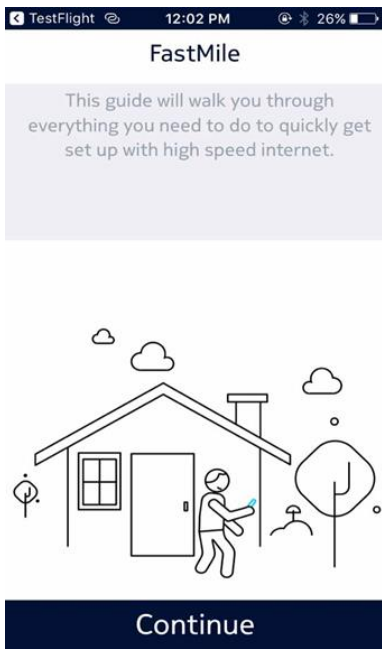


Figure 4 Welcome Screen

Tap on Continue button present on the screen to start Home Outdoor Modem installation procedure.

**Step 2:**

- The Installation App finds the current installation location of the Home Outdoor Modem using GPS and the assigned tower using Controller.

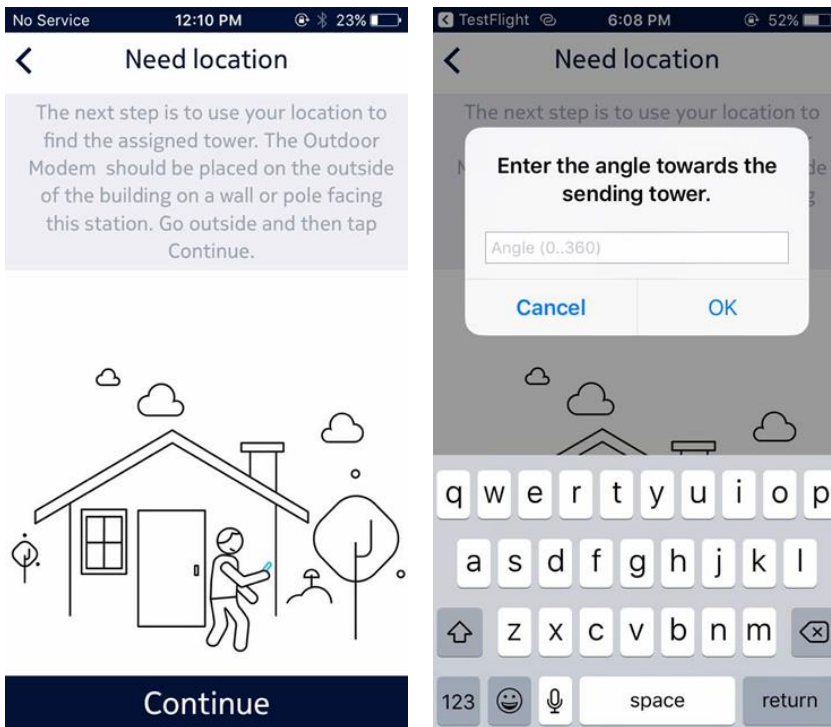
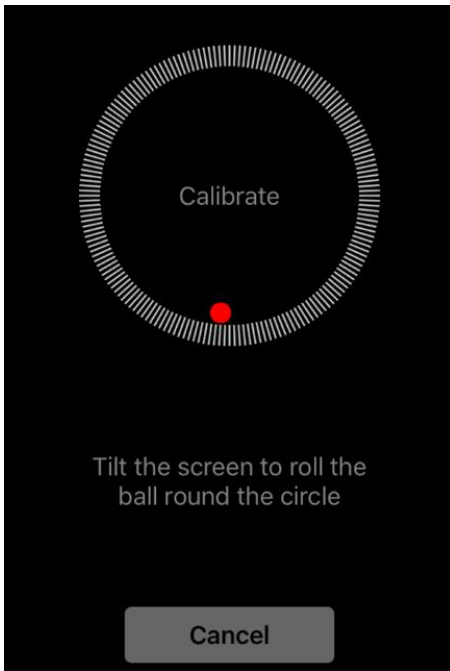


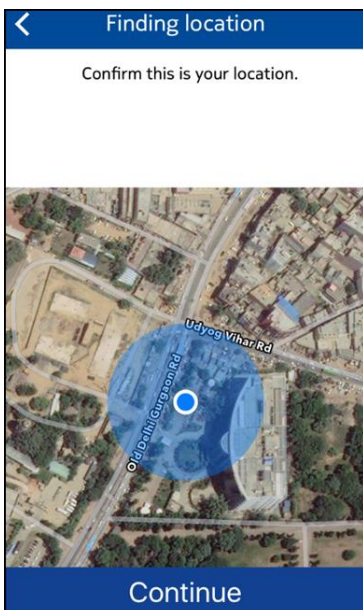
Figure 5 Need Location

- The App may ask for an initial angle towards the sending tower. You may choose to provide the angle that will help in installation or you may Cancel the request that will make the App choose the default angle.
- Tap on Continue button present on the screen to go to next screen.
- The Installation App now provides an option to perform calibration on the phone.



**Figure 6 Phone Calibration**

- The calibration step is recommended but not mandatory. User can also skip this step by just clicking the Cancel button present on the screen.
- After completion of calibration, the next screen on the App asks to confirm the current location of the user.

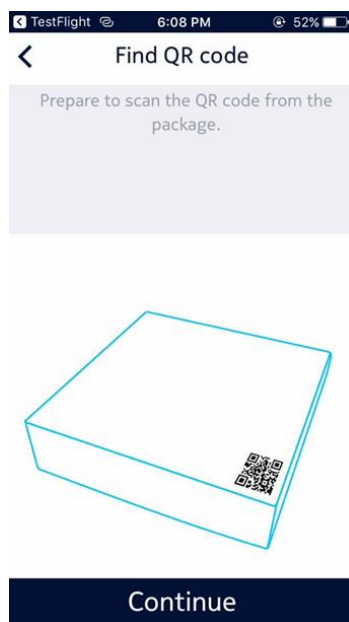


**Figure 7 Finding Location**

- Verify the location shown by the App and tap on Continue button present on the screen to move further.

**Step 3:**

- Now the App asks to scan the QR code of the Home Outdoor Modem to link the Home Outdoor Modem with the App.

**Figure 8 Find QR code**

- Tap the Continue button on the screen when you are ready with the QR code printed on the Home Outdoor Modem package to start the scan procedure.
- A new screen with Viewfinder will then be available to scan the QR code.
- On current screen, a viewfinder is available so that user can align the QR code and scan it.

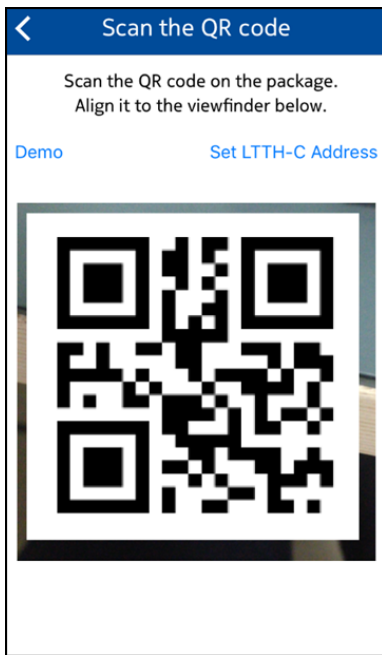


Figure 9 Scan the QR code

#### Step 4:

- The App now provides an option to connect the Home Outdoor Modem with FastMile Controller.

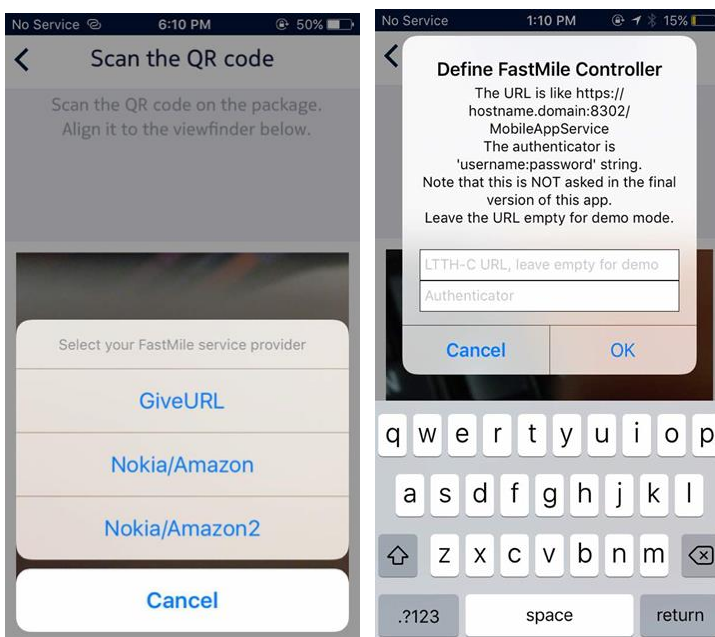


Figure 10 Set FastMile Controller Address

- Select “GiveURL” option to provide FastMile Controller Address manually. A popup screen will appear prompting the user to input the FastMile Controller address.
- Provide the FastMile Controller URL on the Pop Up Screen and click OK to continue further.

**Step 5:**

- The Installation App now instructs the user to open the package and unpack the FastMile Home Outdoor Modem device.

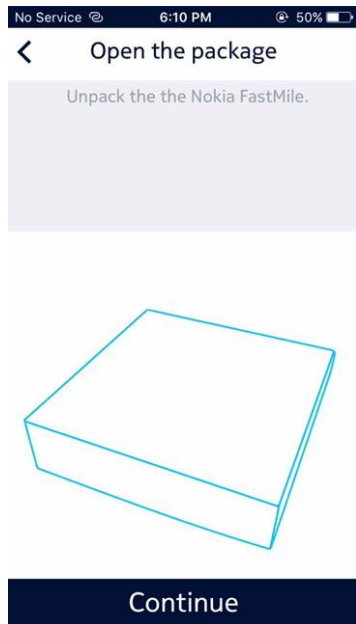


Figure 3 8: Open the package

- Tap on Continue button to go to next screen after opening the package.
- The next screen presents a list of contents that should be present in the package and asks the user to verify his package contents.

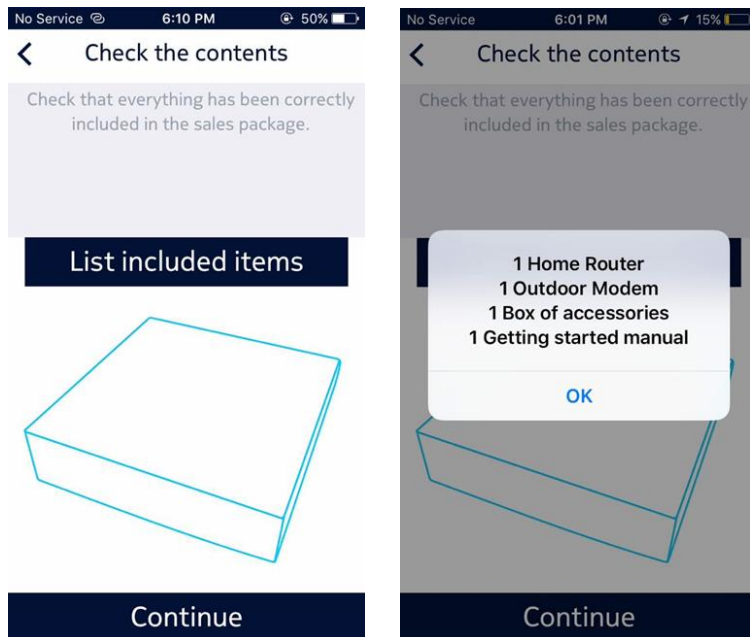
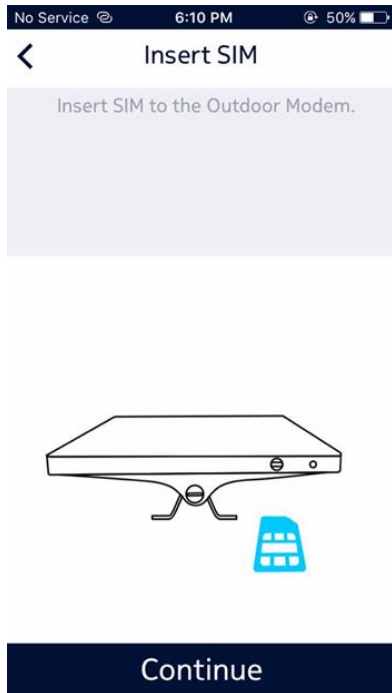


Figure 11 Check the contents

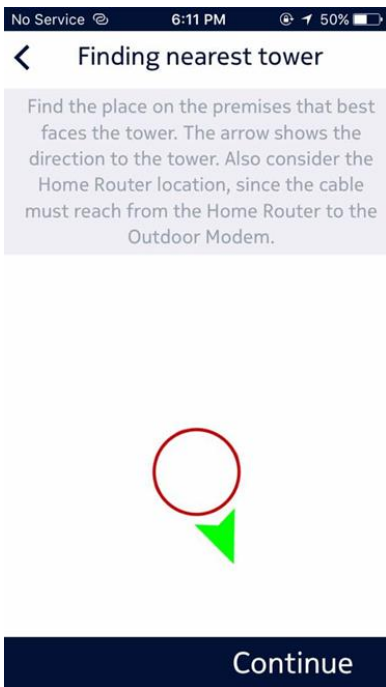
- Tap on Continue button after verification to proceed further.

**Step 6:**

- At this step, the App instructs the User to insert SIM card in Home Outdoor Modem.

**Figure 12** Insert the SIM

- The SIM slot is present in the back side of the Home Outdoor Modem (refer section 2.2 for the SIM slot).
- After Inserting the SIM in the appropriate slot in Home Outdoor Modem, click on Continue button to go to next screen.
- Now the App tries to find the nearest tower on which Home Outdoor Modem has been registered.
- Screen shows the direction and cell ID of tower with respect to the user's current location on map view.

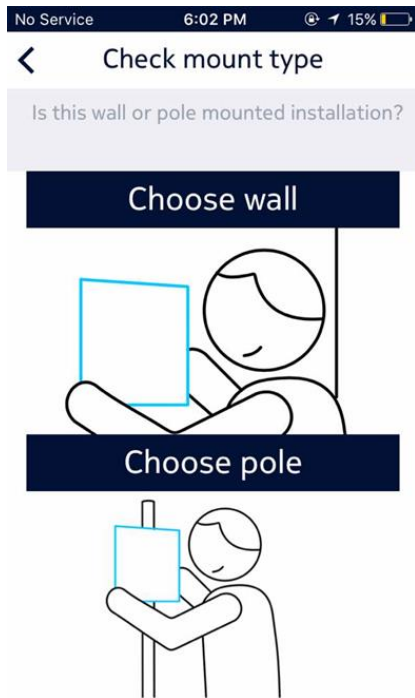


**Figure 13** Finding nearest tower

- Now user has to find a better place on the premises that best faces the tower. Turn towards the direction of the tower and click on Continue.
- The Red circle turns green when user aligns in the direction of the tower.
- If any obstacle like large building or wall is coming in between the tower direction and current location, then user can try the following:
  - Try different angle or location in the premises to face towards the tower.
  - Or user can change the tower by clicking on “Try another tower”.
- As the Red circle turns Green, click on Continue button to go to next step.

## 3.4.2 Mounting Instructions

After Selecting the cell and position on the premises, user needs to choose the mounting type for Home Outdoor Modem.



**Figure 14** Check Mount Type

User needs to select one of the following two mounting types suitable to the location in the premises where it has to install the Home Outdoor Modem.

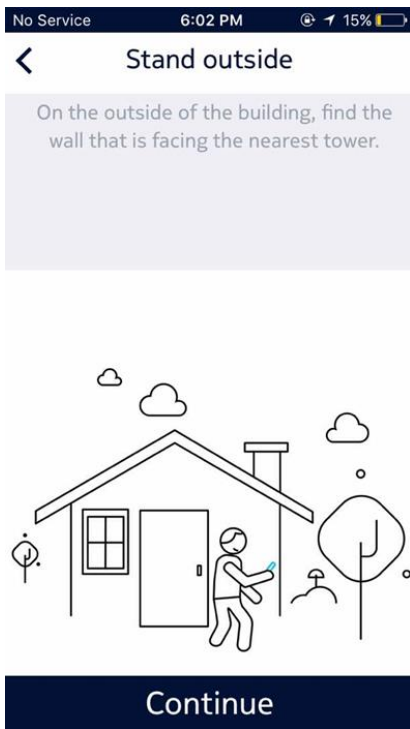
1. Wall mount: Follow the instructions in section 3.4.2.1
2. Pole mount: Follow the instructions in section 3.4.2.2

### 3.4.2.1 Wall Mount Option

#### Step 1:

- In this step Installation App asks user to select the wall on the outside of the building which is facing towards the tower.
- Installation App also instructs the user to move phone towards the wall in a particular manner to calculate the angle between the selected wall and the tower.



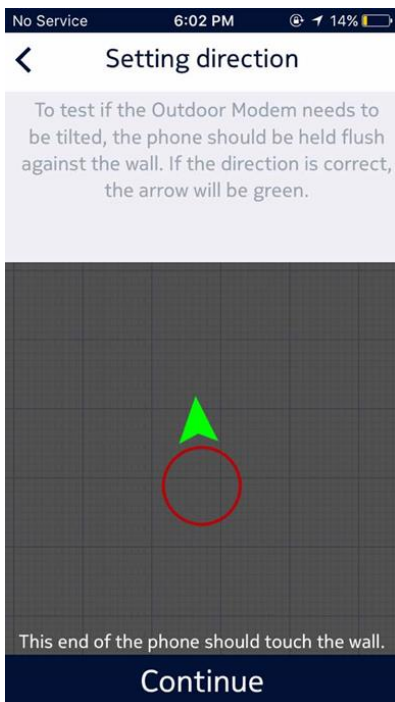


**Figure 15 Wall Selection**

- After selecting the wall, click on Continue to go to next step.

### Step 2:

- A map view will appear on the screen. In this Screen Installation app instructs the user to hold the phone against the wall and turn slowly to get in direction of the selected tower.

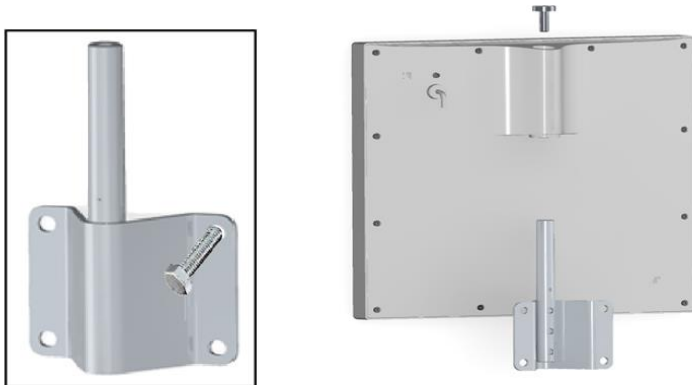


**Figure 16 Setting Direction**

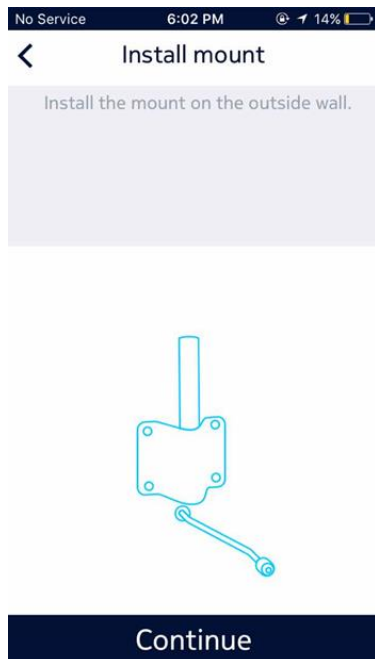
- When user aligns in the direction of tower the arrow becomes Green, it depicts that user can mount the Home Outdoor Modem on wall in this direction.
- After getting direction click on Continue button to go to Next Step.

**Step 3:**

- Now Installation App asks the user to install the mount outside the selected wall.
- Fix the Wall Mounting Anchor to the wall using four bolts. Bolts are not included, select suitable bolts depending on the wall material.

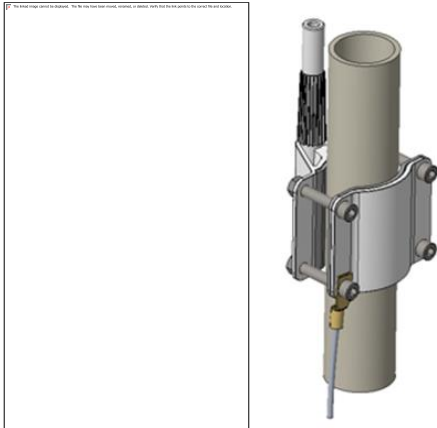


**Figure 17** Bottom view of Wall Mounting Anchor



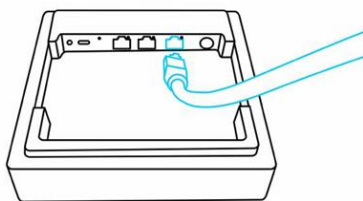
**Figure 18** Install Mount

- Once the Mounting Anchor is fixed to the wall, mount the unit to the wall as per the above figure and tighten the screw.



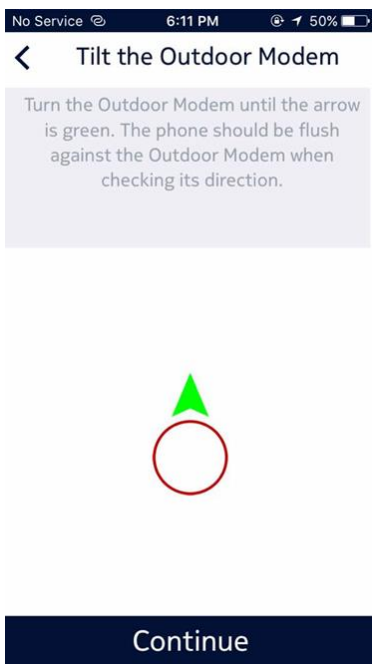
**Figure 19 Earth connection with Wall-mount and Poll-mount Configuration**

- The pole anchor needs to be properly grounded by connecting the anchor bolts to the earthing pit.
- Do not paint on the Home Outdoor Modem.
- Always mount the anchor to the wall using all four screws.
- Once the mounting done, click on Continue button to go to next screen.



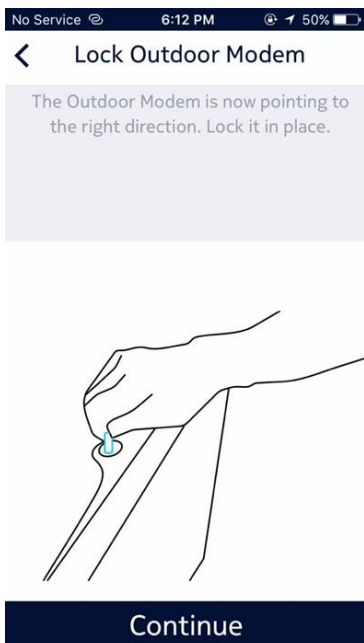
**Figure 20 Connect cable**

- Place the Home Outdoor Modem on the mount.
- Connect the cable (Power over Ethernet cord) between Home Outdoor Modem and Home Router.
- After connecting, click on Continue button to go to next screen.



**Figure 21 Tilt Home Outdoor Modem**

- In this screen Installation App suggest the user to tilt the Home Outdoor Modem.
- This tilt angle is calculated by the Installation App on the basis of selected wall location and the tower.
- After tilting the Home Outdoor Modem, click on Continue to go to next screen.



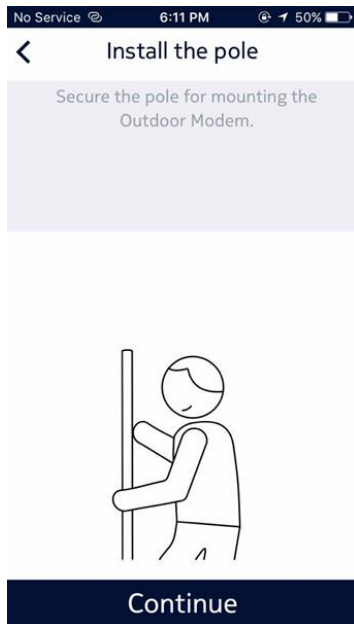
**Figure 22 Lock Home Outdoor Modem**

- Installation App instructs the user to lock the Home Outdoor Modem on the mount and go inside the building.
- Home Outdoor Modem Wall mounting is now completed.

### 3.4.2.2 Pole Mount Option

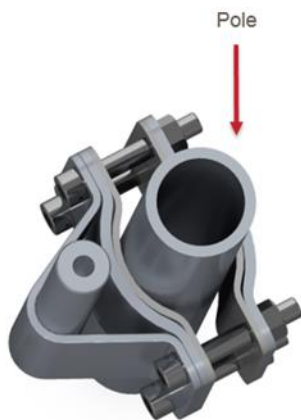
#### Step 1:

- Installation App asks the user to select or install a pole outside the building for mounting Home Outdoor Modem.



**Figure 23** Install the Pole

- The diameter of the pole should be in the range of absolute min 30mm – absolute max 80mm. The recommended minimum diameter would be 35mm for a maximum height of 4m provided the pole is well grounded (fixed). Fix the Pole Mounting Anchor to the pole using four bolts and nuts as shown in the figure below.



**Figure 24** Pole Mount Option

- Once the Mounting Anchor is fixed to the pole, mount the Home Outdoor Modem unit to the pole as shown in the figure below.



**Figure 25** Bottom view of Pole Mount

- Installation App also instructs the user to move phone towards the pole mounted Home Outdoor Modem in a particular manner to calculate the angle between the Home Outdoor Modem on the pole and the tower.

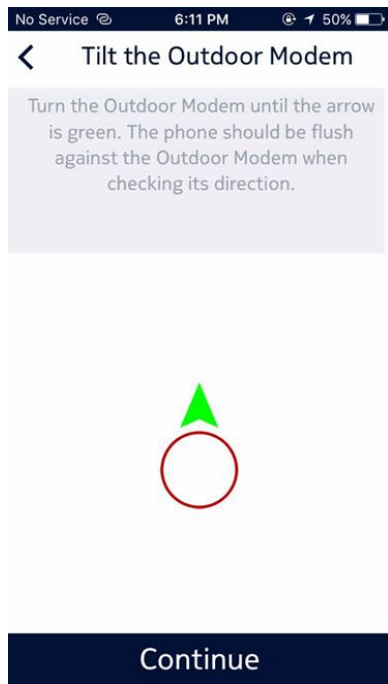


**Figure 26** Setting Direction

- Once the Home Outdoor Modem pole mounting done, click on Continue button to go to next step.

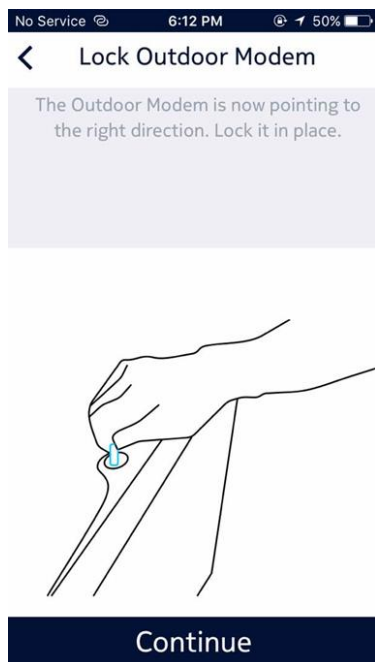
## Step 2:

- The Installation App instructs the user to hold the phone against the Home Outdoor Modem and turn slowly to get the direction of the selected tower.



**Figure 27 Tilt the Home Outdoor Modem**

- When user aligns in the direction of tower the arrow becomes Green, it depicts that user can mount the Home Outdoor Modem on pole in this direction.
- After getting direction click on Continue button to go to Next Step.



**Figure 28 Lock Home Outdoor Modem**

- The Installation App now instructs the user to lock the Home Outdoor Modem on the pole.
- Home Outdoor Modem pole mounting is now completed.

### 3.4.3 Connectivity and power up sequence

The Installation App now guides the user to provide Connectivity to the Home Outdoor Modem Unit and power it ON.

Connect the WAN port of Home Router to the one side of Ethernet Adapter through Cat5e/6 cable. Connect another side of Ethernet Adapter to Home Outdoor Modem using RJ45 connector. Connect the power port of Home Router unit to 54V power adapter output. Turn on the AC mains switch after completing the setup.

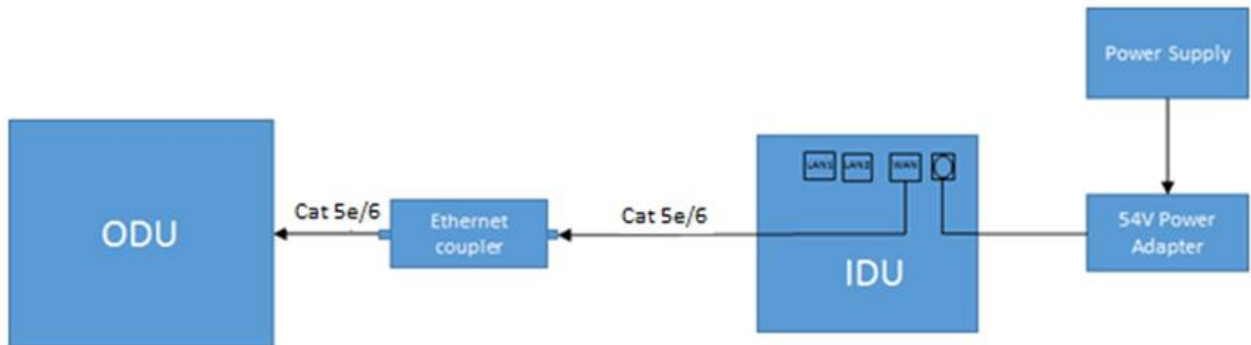


Figure 29 Power sequence of Home Outdoor Modem through Home Router

#### 3.4.3.1 Ethernet Adapter assembly instruction

1. Remove any one side Sealing Nut and Rubber Bush from the Sealing gland of Ethernet Adapter assembly.

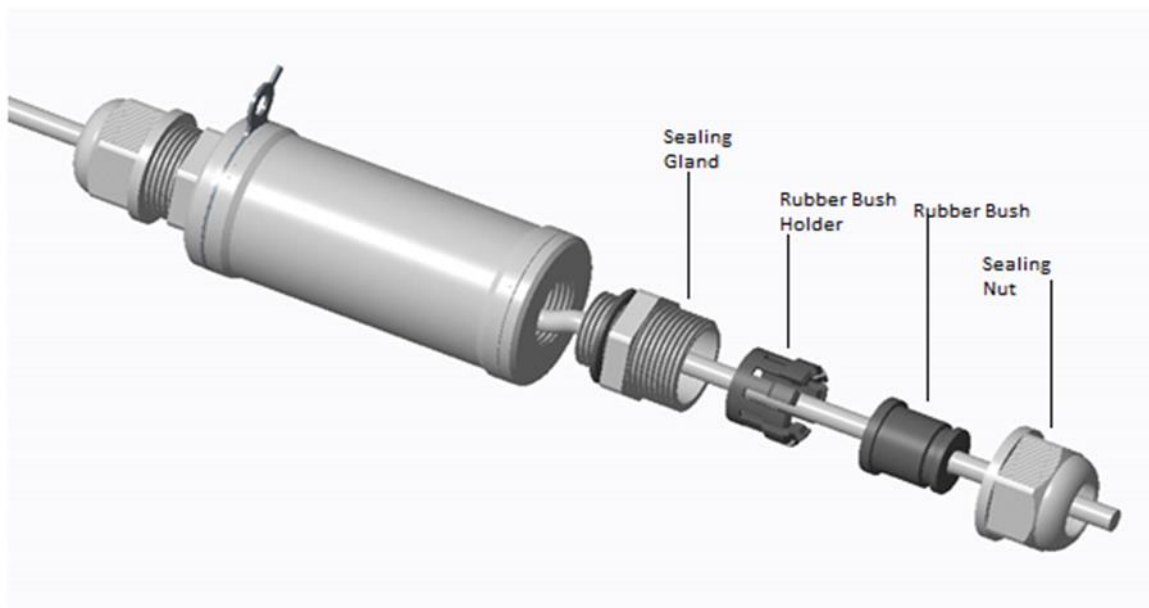


Figure 30 Ethernet Adapter Assembly



2. Insert the Ethernet Wire to the Sealing Nut, Rubber bush and Rubber bush Holder.
3. Connect the RJ45 connector to the one side of Ethernet Adapter inside of Seal.
4. Fix the rubber bush to the Rubber Bush Holder and then fix it to the Sealing Gland. Fix the Sealing Nut to Sealing Gland.
5. Repeat Step-1 to Step-4 for another side of Ethernet Adapter assembly.

### 3.4.3.2 Connection to Home Router

Connect the Ethernet Cable from Home Outdoor Modem to Home Router for Power Supply and Connection Establishment.

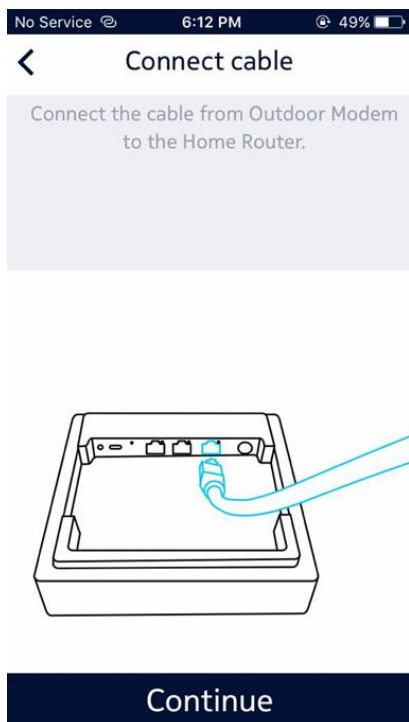


Figure 31 Connect Cable

### 3.4.3.3 Power Up Sequence

Connect Power Cable to the Home Router to Power UP both Home Router and Home Outdoor Modem devices and complete the setup.

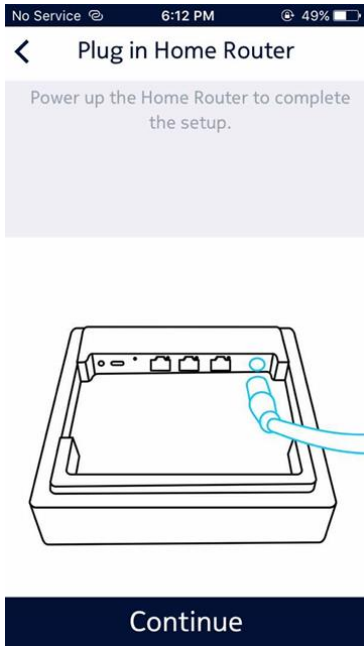


Figure 32 Plug in Home Router

Once the connectivity and Power up scenario has been completed, the Installation App shows the status of Installation procedure.

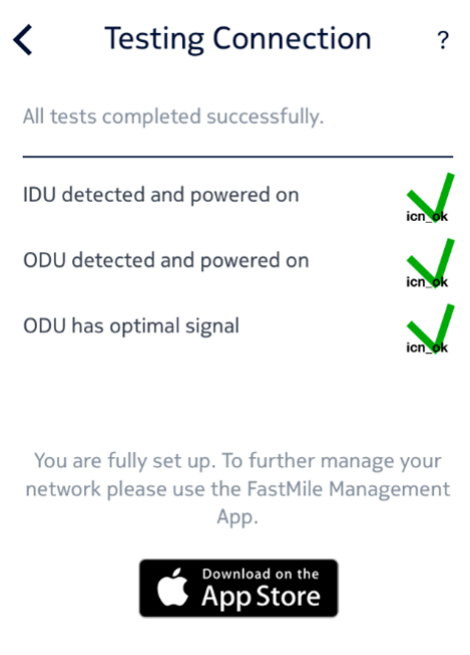


Figure 33 Testing Connection

All Green Ticks shows that Home Outdoor Modem installation has been completed successfully.

### 3.4.4 Managing Home Outdoor Modem through Management app

Once the Home Outdoor Modem is properly installed on the wall/pole outside the premises and connected with the Home Router, you need to manage the Home Outdoor Modem device.

You are provided with one more phone application, the Management app. With the help of this app, you can perform the following actions on Home Outdoor Modem:

- Firmware upgrade of Home Outdoor Modem
- Check Home Outdoor Modem connectivity with the LTE network.

These actions are described in the below sub-sections.

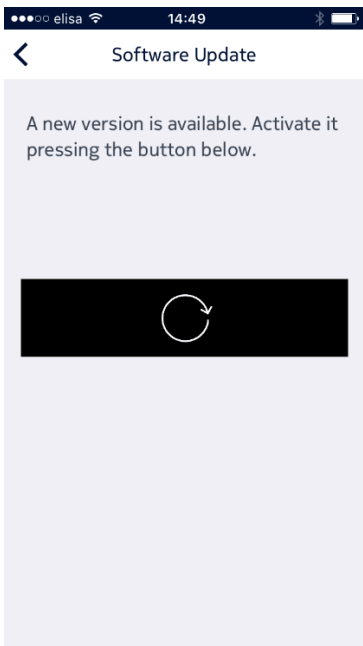
#### 3.4.4.1 Home Outdoor Modem Firmware Upgrade

- Management app shows the latest available Software Updates for both Home Outdoor Modem and Home Router.



**Figure 34** Software Update Available

- You can check for the updated version available by clicking the Update available. You can install and activate the latest software updates by clicking “Restart CPE and Update” button on screen.

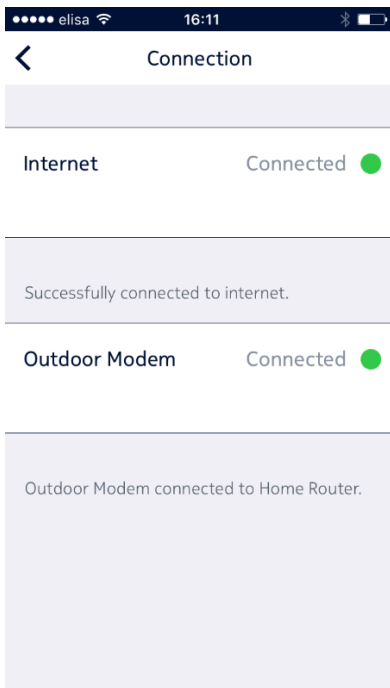


**Figure 35** Install Updates

### 3.4.4.2 Home Outdoor Modem Connectivity

Management app shows the connectivity between the Home Outdoor Modem and LTE network on Connection screen. If Home Outdoor Modem is not connected with LTE network, then Internet connection changes from Green to Red in Management app.

Management app also shows connectivity between Home Outdoor Modem and Home Router. If connectivity between Home Outdoor Modem and Home Router is lost, then Home Outdoor Modem connection changes from Green to Red in Management app.



**Figure 36** Connection

---

## 4 Troubleshooting

This chapter contains the common issues along with their resolutions that a user might face while installing/familiarizing with Home Outdoor Modem.

### 4.1 Common Problems during Installation and startup Phase

#### 4.1.1 Home Outdoor Modem is not registered.

**Root cause(s):**

Registration is not done for the Home Outdoor Modem. BS/Cell must be assigned for each Home Outdoor Modem before given to customer. This registration typically happens in Point-of-Sales (PoS).

**Indication(s) to user:**

When install App asks Controller the BS location for a given Home Outdoor Modem, Controller gives a <status> with error code 2, "NTE is not registered". The application indicates this error code as "NTE not registered".

**Resolution(s):**

Home Outdoor Modem must be returned to PoS for registration.

#### 4.1.2 Home Outdoor Modem registration fails at Controller

**Root cause(s):**

Incorrect HW version or Product Class is provided while Registering Product Category at Controller.

**Indication(s) to user:**

Home Outdoor Modem is not present under 'Find CPE' tab at Controller.

**Resolution(s):**

Rectify HW version and/or Product Class value while Registering Product Category at Controller and Perform Home Outdoor Modem Reboot or Factory Reset.

#### 4.1.3 Home Outdoor Modem is registered to a wrong BS/Cell

**Root cause(s):**

Error in providing the right input in the registration (e.g., street address of the Home Outdoor Modem installation location). As a result, Home Outdoor Modem cannot create (proper) LTE connection to the assigned BS/Cell by using narrow-beam antenna.

**Indication(s) to user:**

Error is seen only after the system is installed.

LEDs in Home Outdoor Modem and Home Router show an error. LEDs at both Home Router and Home Outdoor Modem will be Flashing (2Hz) orange.

Smartphone application shows error "Cannot connect to the assigned cell".

The signal strength is too low. LEDs in Home Outdoor Modem and Home Router may indicate this.

**Resolution(s):**

Visit Point-of-Sales or call Service Desk to re-register the Home Outdoor Modem for a new BS/cell.

Given the new, right registration input, the Controller must be able to cancel the previous registration (BS-CPE mapping), release the capacity reservation for the CPE from the wrong BS/cell, and make a new registration (BS-CPE mapping).

When Home Router is installed (again) after re-registration, it boots and creates the initial connection to the Controller. The Controller commands the Home Router to switch to reset-to-factory-defaults. After that the Installation procedure between the CPE and Controller continues normally with BS/cell assignment by the Controller to CPE and CPE antenna alignment to the right BS/cell.

Note: In the worst case it will be necessary to re-install the Home Outdoor Modem to a different wall after re-registration.

#### **4.1.4 Home Outdoor Modem installation application cannot connect to the Controller**

**Root cause(s):**

The Home Outdoor Modem installation application needs IP (internet) connection to connect to Controller, but internet connection is not available.

**Indication(s) to user:**

The Home Outdoor Modem installation application shows "Cannot connect to LTTH-C".

**Resolution(s):**

Arrange internet connection for the Home Outdoor Modem installation application (3G, 4G, LTE).

Home Outdoor Modem cannot connect to the Controller

**Root cause(s):**

Home Outdoor Modem needs IP (internet) connection to connect to Controller and tries to connect during the first-time boot by using antenna wide-beam mode but with no success.

The LTE/FastMile network field strength is most likely too weak for the Home Outdoor Modem location. This may be due to the Home Outdoor Modem being located on the wrong wall/pole or an operator's network plan is having coverage gap.

Another cause for this could be that the Controller is temporarily down.

**Indication(s) to user:**

LEDs on Home Outdoor Modem and Home Router show an error. LEDs on both Home Router and Home Outdoor Modem will be Flashing (2Hz) orange.

Smartphone application shows error message "Cannot connect to LTTH-C".

**Resolution(s):**

Home Outdoor Modem restart may help to fix "Controller-is-down" case.

If connection is not successful in the wide beam mode, the Home Outdoor Modem tries to scan in the narrow beam mode.

If Home Outdoor Modem appears to be installed to a wrong wall/pole, the installation process is re-done.

If the root cause is the gap in the network coverage, the operator must do network re-planning/adjustments to serve the Home Outdoor Modem location.

If the Controller is down, operator needs to bring up the same to establish connection between Home Outdoor Modem and Controller.

## **4.1.5 Home Outdoor Modem cannot form the LTE connection by using the narrow-beam.**

### **4.1.5.1 Automatic cell re-assignment during Home Outdoor Modem installation is possible**

**Root cause(s):**

Any reason why service can not be provided using the original Cell Id allocation.

**Indication(s) to user:**

In the 'setODUState' message the Home Outdoor Modem indicates to Controller that the Home Outdoor Modem cannot connect to the assigned cell in the initial setup phase but the Home Outdoor Modem could connect to another cell.

LEDs on both Home Router and Home Outdoor Modem will be Flashing (2Hz) orange.

**Resolution(s):**

The Home Outdoor Modem scans the tunable range for cell candidates using narrow beam and picks up best available cell. The Home Outdoor Modem sends the 'setODUState' message with the new cell candidate. If the candidate cell is suitable based on the Controller

assessment, the Controller re-assigns a new cell for the Home Outdoor Modem. The Home Outdoor Modem shall start with factory-default behavior (i.e. get a new Cell Id to be used).

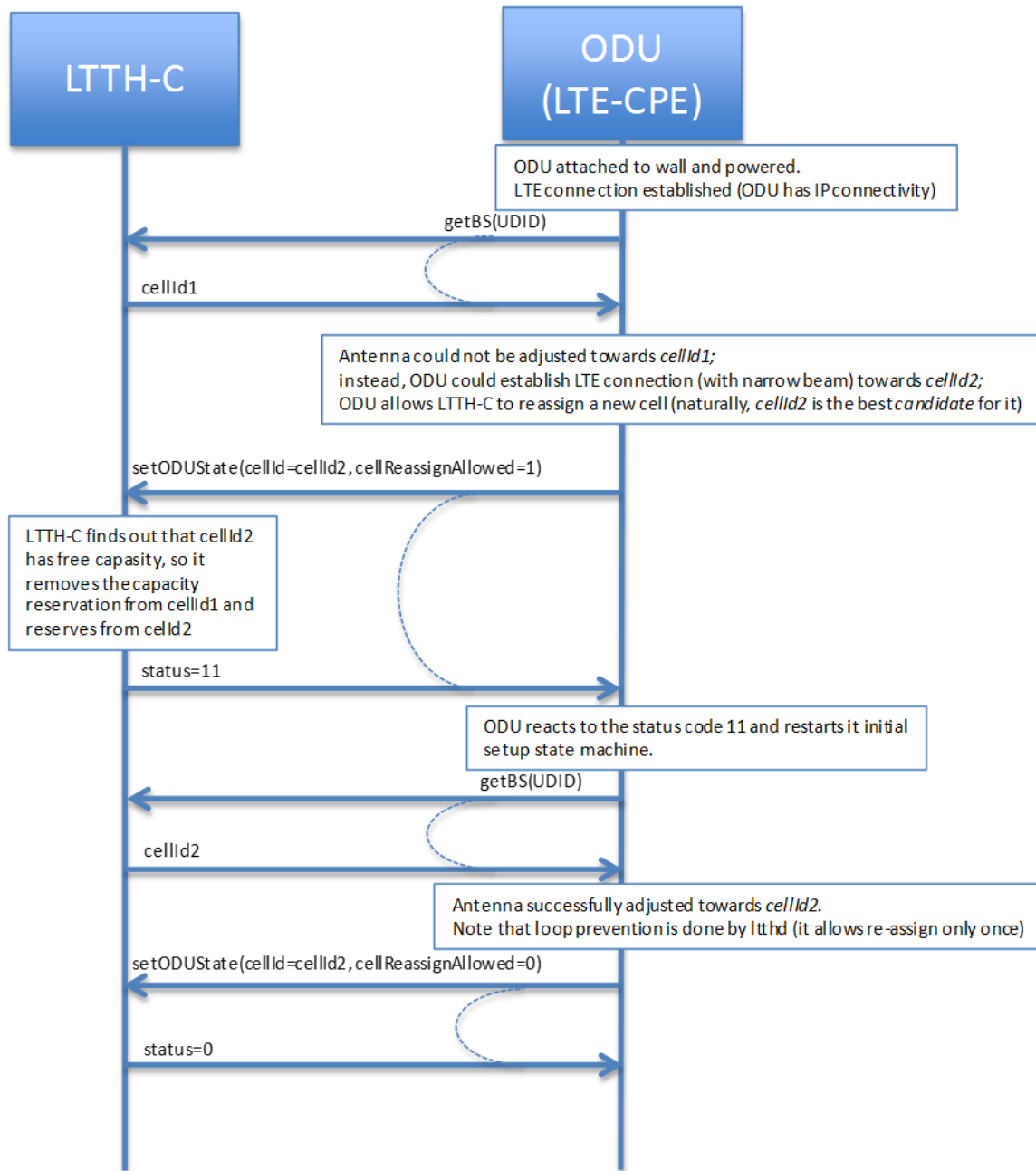


Figure 37 Cell re-assignment during Home Outdoor Modem Installation Procedure

### 4.1.5.2 Other cell re-selection cases

**Root cause(s):**

Home Outdoor Modem is placed to the wrong wall.

The manual tilt is at a wrong position.

The serving cell may be down.



**Indication(s) to user:**

LEDs in Home Outdoor Modem and Home Router show error. LEDs at both Home Router and Home Outdoor Modem will be Flashing (2Hz) orange.

Smartphone application shows error message "Cannot connect to assigned cell".

Home Outdoor Modem informs Controller about its state, "cannot connect" in a HTTP/JSON 'request' message.

**Resolution(s):**

If serving cell is down, the Controller must get information from the network management system (NetAct) of the root cause ("cell is down"). The Controller gives a 'response' with reason "cell is down" to Home Outdoor Modem's 'request' "cannot connect". If possible (according to the capacity plan), Controller re-allocates another Cell Id to Home Outdoor Modem.

If the manual tilt is wrong another tilt angle is manually adjusted. Home Outdoor Modem restart is needed in this case.

If Home Outdoor Modem appears to be installed to a wrong wall, the installation process is re-done.

### **4.1.6 Cable between Home Outdoor Modem and Home Router not properly connected**

**Root cause(s):**

There are problems with PoE cable between Home Outdoor Modem and Home Router. The cable is not properly connected to Home Router and/or Home Outdoor Modem side or the cable is broken.

**Indication(s) to user:**

LED in Home Router shows error. LED at Home Router will be Flashing (2Hz) orange.

LED in Home Outdoor Modem is dead (no power!).

Smartphone application shows error "Cannot connect to NTE, check cable".

**Resolution(s):**

Fix cabling issues.

### **4.1.7 SIM is not inserted**

**Root cause(s):**

SIM is not in place in the Home Outdoor Modem. SIM must be installed before Home Outdoor Modem is set up.

**Indication(s) to user:**

LEDs in Home Outdoor Modem and Home Router show error.

Smartphone application shows error "No SIM" or "SIM error".

**Resolution(s):**

Insert/re-insert SIM in Home Outdoor Modem. Note: the Home Outdoor Modem is in the wall already!

Home Outdoor Modem restart is needed for SIM detection.

### 4.1.8 Invalid PIN

**Root cause(s):**

If SIM has a PIN, the PIN must be defined in Home Outdoor Modem variant pre-configuration (i.e. factory-configured). When PIN configured in Home Outdoor Modem differs from PIN in SIM, LTE connection is not established.

**Indication(s) to user:**

LEDs in Home Outdoor Modem and Home Router show error. LEDs at both Home Router and Home Outdoor Modem will be Flashing (2Hz) orange.

Smartphone application shows error "SIM PIN error".

**Resolution(s):**

Use smartphone application to change the SIM PIN with the help of SIM PUK.

### 4.1.9 Home Outdoor Modem is not able to attach to LTE Network due to Incorrect APN

**Root cause(s):**

Default APN at Home Outdoor Modem is different than LTE Network's APN. Default APN block at Home Outdoor Modem is left blank.

**Indication(s) to user:**

Home Outdoor Modem LED status is blinking orange.

**Resolution(s):**

This is a factory configuration issue. Contact vendor for Factory Configuration Update.

---

## 4.2 Common Problems during Execution Phase

### 4.2.1 Home Outdoor Modem Provisioning is not successful after reboot/factory reset

**Root cause(s):**

While updating config file `cpe.variant.conf/ltthd.variant.conf` files at `opt/Nokia/var/common/data/`, some extra text is added in file.

Incorrect value of a parameter is provided in Config File.

**Indication(s) to user:**

Home Outdoor Modem LED remains solid orange.

**Resolution(s):**

Verify any extra/missing text by comparing it with any working setup or from backup files if taken.

Verify the values in Config Files for essential parameters.

### 4.2.2 Home Outdoor Modem firmware upgrade to latest build failed

**Root cause(s):**

Reboot given to Home Outdoor Modem before flashing gets completed.

**Indication(s) to user:**

In `cpe.variant` file, older build version is shown.

**Resolution(s):**

Verify boot file status at `opt/Nokia/var/common/data` before giving reboot to Home Outdoor Modem. Its value should be 1.

Home Outdoor Modem LED status should be changed to blinking green after flashing get completed. Reboot should be given after that.

Alternatively software update status can be checked from command, `cpe_ctrl swupdatestatus`. When output of this command is 1, reboot should be given only after that.

---

### 4.2.3 Home Outdoor Modem is not able to communicate with Controller after firmware upgrade

**Root cause(s):**

Controller URLs (connection management/JSON) are wrong in `ltthd.variant.conf` file at `/opt/Nokia/var/common/data/` after firmware upgrade.

**Indication(s) to user:**

Home Outdoor Modem LED status changed to blinking orange.

**Resolution(s):**

Controller URL should be changed as per available set up both for connection Management server & JSON URL.

### 4.2.4 Home Outdoor Modem detached from network

**Root cause(s):**

LTE cell goes down.

**Indication(s) to user:**

Home Outdoor Modem LED status changed to blinking orange.

**Resolution(s):**

Perform Factory reset on Home Outdoor Modem (see Appendix A: Factory Settings). If another cell is available at Controller, Home Outdoor Modem will attach on that cell automatically through Cell-Reassignment.

If Problem persists, contact operator.

## 5 Appendix A: Factory Settings

You can return the Home Outdoor Modem to its factory settings. Use the end of a paper clip or a similar object to press and hold the Reset button on the back of the unit for at least five seconds.

The router resets and returns to the factory configuration settings shown in the following table.

FEATURE	Default Behavior
LTE Login	
User login URL	
User name (case-sensitive)	
Login password (case-sensitive)	
Ethernet	
WAN IP	192.168.254.1
Subnet mask	255.255.255.0
DHCP server	Enabled
DHCP range	192.168.254.66 to 192.168.254.126
DHCP starting IP address	192.168.254.66
DHCP ending IP address	192.168.254.126

**Table 8** Factory settings

## 6 Appendix B Specifications

FEATURE	DESCRIPTION
Altitude	≤ 2000m
Dimension	406x406x30mm at the edges and 80mm at the hinge location
Weight	3 kg
Operating temperature	-30°C to 65°C (Arctic variant) -20°C to 65°C (Standard variant)
Storage temperature	-40°C to 85°C
Operating humidity	0% to 93% non-condensing
IP Rating	IP65 Ingress
Power consumption	<9W

**Table 9** Specifications

---

## 7 Appendix D FCC Compliance Statement

### FCC ID: 2AL7J-FMHOMN0041

Valid only for Band 41 usage.

- 1) This device may not cause harmful interference, and
- 2) This device must accept any interference received, including Interference that may cause undesired operation.

### FCC Caution!!!

- Any changes or modifications not expressly approved by the party responsible for compliance could void the user's authority to operate this equipment.
- This equipment should be installed at a minimum height of 2.5 meters from the ground plane and operated with minimum distance 50 cm between the radiator & your body.

This equipment generates, uses and can radiate radio frequency energy and, if not installed and used in accordance with the instructions, may cause harmful interference to radio communications. However, there is no guarantee that interference will not occur in a particular installation.

If this equipment does cause harmful interference to radio or television reception, which can be determined by turning the equipment off and on, the user is encouraged to try to correct the interference by one or more of the following measures:

- Reorient or relocate the receiving antenna.
- Increase the separation between the equipment and receiver.
- Connect the equipment into an outlet on a circuit different from that to which the receiver is connected
- Consult the dealer or an experienced radio/TV technician for help.

For more information, please contact your local Nokia support.