

1. Remove connector seal from OPT1 connector in ESMB/C.
2. Remove protective cap from optical transceiver and insert it into OPT1 in ESMB/C.
3. Route optical cable through cable entry.
4. Uncover the connector. Pull back the optical cable connector seal to uncover the connector.
5. Remove protective plugs.
6. Clean connectors with 99% alcohol and swabs.
7. Connect optical cable to optical transceiver in ESMB/C.
8. Push connector seal firmly.
9. Repeat steps 1-8 to connect optical transceiver and optical cable to OPT1 of FXxx.
10. Ensure all connector seals are properly installed.

### Check list

- DC power cables are connected and the cable clamp is in place.
- Connector seals are firmly in place.
- All cables are connected according to the configuration.
- BTS external cables or cables between the modules on different plinths are routed via cable entries.
- Connector seals are **firmly in place**.
- To avoid cabling rework, check that the unit powers on before tying down the cables.

## 9 Powering up and commissioning the BTS

1. Power up the site and check the LEDs.
2. Commission the BTS.

Note: For commissioning the BTS, see *Commissioning Flexi Multiradio BTS GSM/EDGE* document and *Quick Guide for Flexi Multiradio BTS GSM/EDGE Commissioning*

# 10

## Installing module front covers

### Maintenance strap

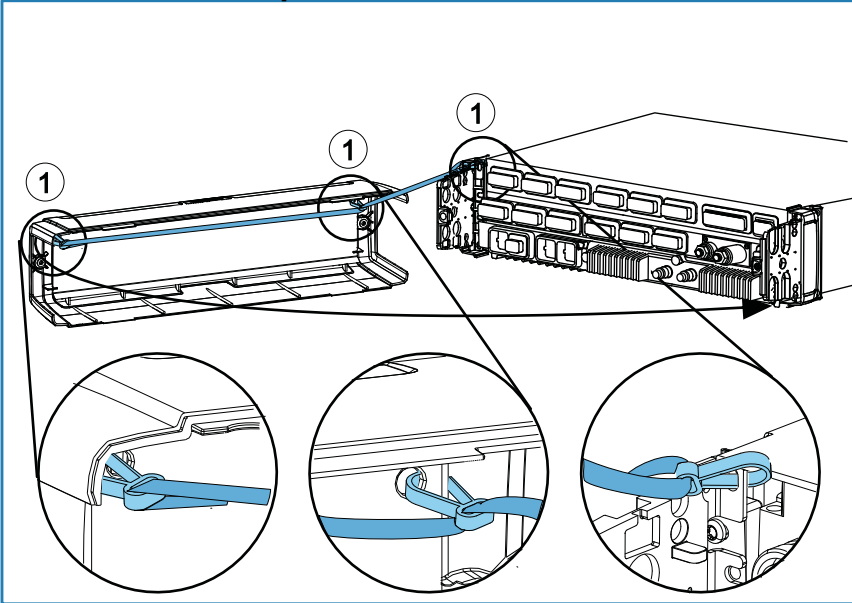

### Module front covers

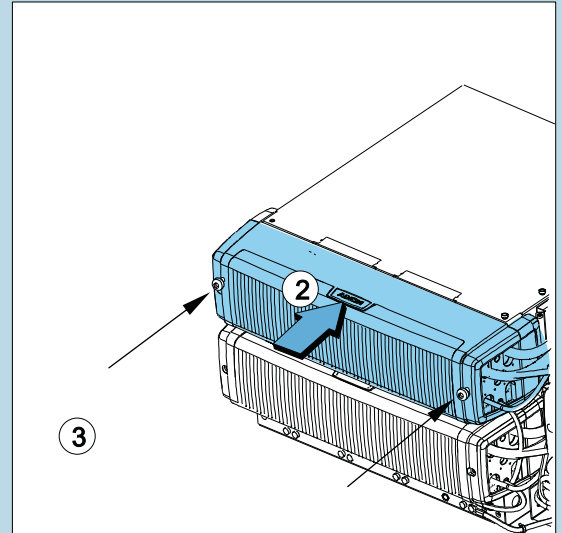

1. Fix the maintenance strap. (Pole or wall only)  
Attach the first and second snap hooks of the maintenance strap to the front cover.  
Attach the third snap hook of the maintenance strap to the external cable entry.
2. Place the cover on top of the module front panel.
3. Fix the screws. Tighten the screws to 2.0 - 2.5 Nm (1.5-1.8 ft-lb)

### Check list

- Module front panel covers are installed.

# 11

## Removing modules with the pull-out tool (for maintenance only)

### Removing System Module with the pull-out tool

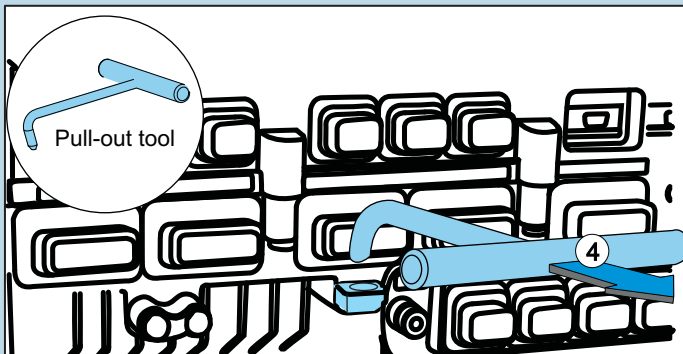

**Caution: Do not completely remove the module or carry it with the pull-out tool.**

1. Remove the front covers and cable entries.
2. Remove the module screws.
3. Hook the pull-out tool through the hole in front of the module.
4. Pull until the unit comes loose.

# Installation check list



**Perform these checks to make sure that the installation is complete:**

- Delivery is complete and undamaged.
- Site meets the minimum clearances.
- Plinth is installed according to the instructions.
- Plinth is grounded.
- Modules are installed according to the instructions.
- One module per casing is grounded to the plinth.
- External power cables are connected.
- Internal power cables are connected.
- Optical cables are connected.
- Antenna jumper cables are connected.
- Transmission cables and sub-modules are connected.
- BTS external cables or cables between the modules on different plinths are routed via cable entries.
- All boots and caps are properly connected and IP-sealed.
- Screws are tightened to the specified torque value.  
Note: In pole and wall installations, screws are secured with thread locking compound.
- Only IP65 class cables with seals provided by Nokia Siemens Networks are used.
- BTS is switched on and all units are ready.
- Module front covers are installed.
- Site is clean and installation completed.
- Optional cables (EAC, Synchronization, Site support interface, FPA interface, LMP cables, RF cables) are connected.