

# Flexi Multiradio BTS Quick Guide



This guide can be used as quick reference for Flexi Multiradio BTS installation.

Flexi Multiradio BTS is a macro BTS site solution. It consists of one System Module with a transmission sub-module and RF Modules. It can be installed stacked on the floor, or mounted on the wall or on the pole.

This quick guide is for basic stand-alone installation only. For other installation options, see operating documentation.

## Check the delivery

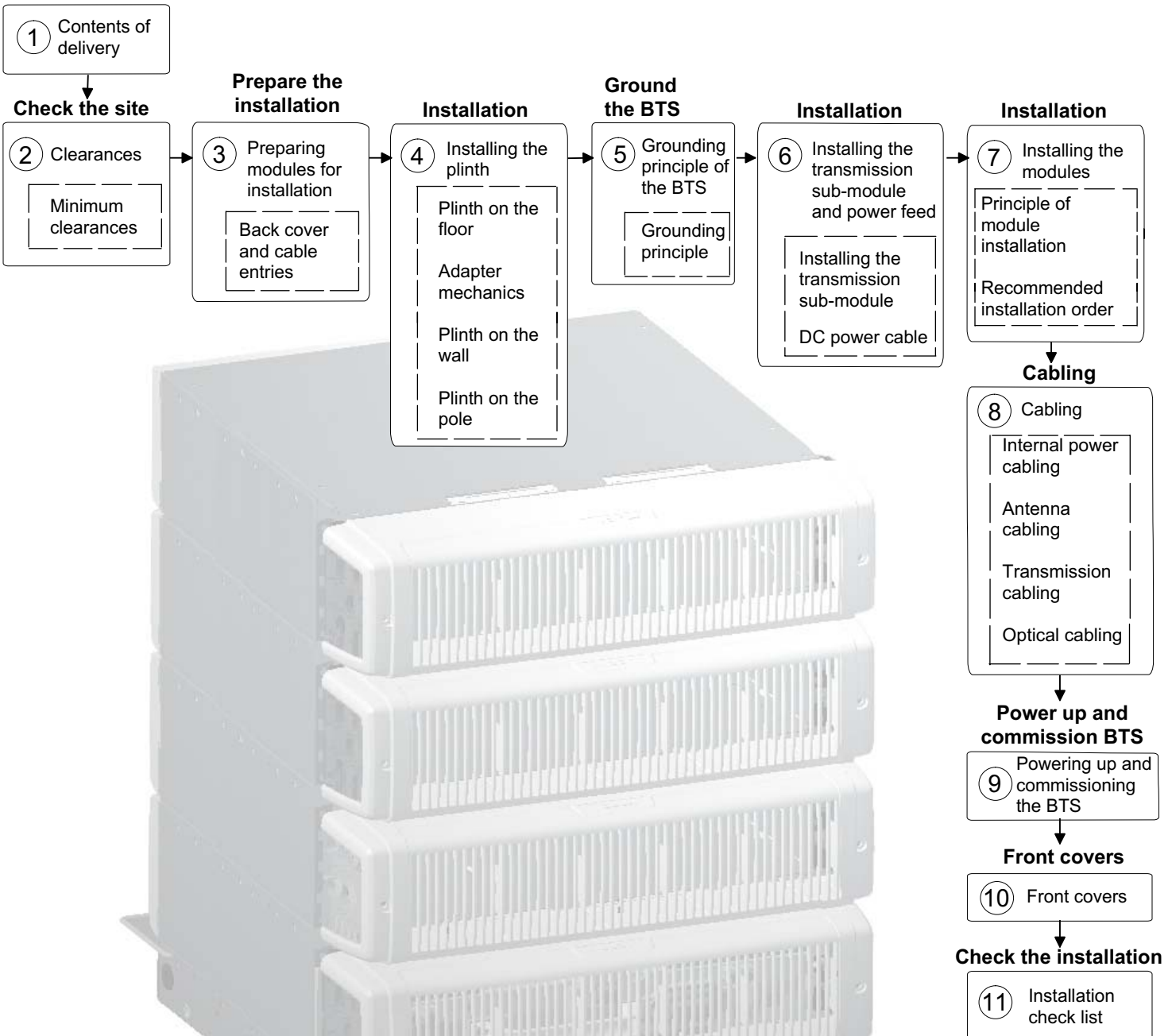

The information in this document is subject to change without notice and describes only the product defined in the introduction of this documentation. This document is not an official customer document and Nokia Siemens Networks does not take responsibility for any errors or omissions in this document. This document is intended for the use of Nokia Siemens Networks customers only for the purposes of the agreement under which the document is submitted. No part of this documentation may be used, reproduced, modified or transmitted in any form or means without the prior written permission of Nokia Siemens Networks. The documentation has been prepared to be used by professional and properly trained personnel, and the customer assumes full responsibility when using it. Nokia Siemens Networks welcomes customer comments as part of the process of continuous development and improvement of the documentation.

The information or statements given in this documentation concerning the suitability, capacity or performance of the mentioned hardware or software products are given "as is" and all liability arising in connection with such hardware or software products shall be defined conclusively and finally in a separate agreement between Nokia Siemens Networks and the customer.

IN NO EVENT WILL Nokia Siemens Networks BE LIABLE FOR ERRORS IN THIS DOCUMENTATION OR FOR ANY DAMAGES, INCLUDING BUT NOT LIMITED TO SPECIAL, DIRECT, INDIRECT, INCIDENTAL OR CONSEQUENTIAL OR ANY LOSSES SUCH AS BUT NOT LIMITED TO LOSS OF PROFIT, REVENUE, BUSINESS INTERRUPTION, BUSINESS OPPORTUNITY OR DATA, that might arise from the use of this document or the information in it. THE CONTENTS OF THIS DOCUMENT ARE PROVIDED "AS IS". EXCEPT AS REQUIRED BY APPLICABLE MANDATORY LAW, NO WARRANTIES OF ANY KIND, EITHER EXPRESS OR IMPLIED, INCLUDING, BUT NOT LIMITED TO, THE IMPLIED WARRANTIES OF MERCHANTABILITY, FITNESS FOR A PARTICULAR PURPOSE AND NON-INFRINGEMENT, ARE MADE IN RELATION TO THE ACCURACY, RELIABILITY OR CONTENTS OF THIS DOCUMENT. NOKIA SIEMENS NETWORKS RESERVES THE RIGHT TO REVISE THIS DOCUMENT OR WITHDRAW IT AT ANY TIME WITHOUT PRIOR NOTICE.

This document and the product it describes are considered protected by copyrights and other intellectual property rights according to the applicable laws.

The wave logo is a trademark of Nokia Siemens Networks Oy. Nokia is a registered trademark of Nokia Corporation. Siemens is a registered trademark of Siemens AG.

Other product names mentioned in this document may be trademarks of their respective owners, and they are mentioned for identification purposes only.

Copyright © Nokia Siemens Networks 2010. All rights reserved.

DN0951796 version 01



### Warning

Invisible laser radiation from the module optical fibre connector.  
Always switch off the laser before detaching the optical fibre from the connector.



### Caution

Incorrect cables and seals may not provide secured weather protection. In outdoor installations, including the outdoor cabinet, use only tested IP55 class outdoor cables with seals provided by Nokia Siemens Networks. This is also recommended for indoor installations.

Electrostatic discharge (ESD) may damage the modules. Wear an ESD wrist strap or use a corresponding method when handling the modules.

The plinth rear stopper is fragile. Do not attempt to lift the plinth using the rear stopper.

Delivery	Contents	Versions	Codes		
System Module delivery	System Module with casing	FSMB 3 FSPA	470036A		
		FSMC 1 FSPC	471401A		
		FSMD 2 FSPC	471402A		
		FSME 2 FSPC	471469A		
	ESD wrist strap				
	2 x cable clamps				
	Stress relief plate for the power cable				
	2 x M5 screws, 4 x K30 screws				
	20 x cable ties				
RF Module delivery	RF Module with casing	FRIA 1.7/2.1 GHz Dual 50 W	471000A		
		FRIB 1.7/2.1 GHz Single 50 W	471215A		
		FRGC 2100 MHz Dual 50 W	471231A		
		FRGD 2100 MHz Single 50 W	471232A		
		FRGF 2100 MHz 3-sector	471483A		
		FRGJ 2100 MHz Dual 50 W	471820A		
		FRGK 2100 MHz Single 50 W	471821A		
		FRGL 2100 MHz Dual 50 W	471834A		
		FRGM 2100 MHz Single 50 W	471835A		
		FRCA 850 MHz Dual 50 W	471266A		
		FRCB 850 MHz Single 50 W	471268A		
		FRDA 900 MHz Dual 50 W	471265A		
		FRDB 900 MHz Single 50 W	471267A		
		FRFA 1900 MHz Dual 50 W	471017A		
		FRFB 1900 MHz Single 50 W	471273A		
		FRKA 1500 MHz 3-sector	472111A		
		FRGP 2100 MHz 3-sector	472100A		
		FRIE 1.7/2.1 GHz 3-sector	471895A		
		FXDA 900 MHz 3-sector	472083A		
		FXCA 850 MHz 3-sector	472142A		
		FXEA 1800 MHz 3-sector	472084A		
		FRGR 2100 MHz 1-sector	472251A		
		FRHA 2600 MHz 3-sector	471894A		
		FRMA 800EU MHz 3-sector	472221A		
			Optical cable		994807A
			Power cable		994808A
			Optical transceiver		4807528
	2 x M5 screws				
	10 x cable ties				
Remote Radio Head delivery	Remote Radio Head	FRGG 2100 MHz	471882A		
		FRGQ 2TX 2100	472261A		
		FHDA 2TX 900	472167A		
		FRIF 2TX 1.7/2.1	472260A		
		FRMB 2TX 800EU	472291A		
Transmission sub-module deliveries	FTPB with 8 x rubber plugs, 4 screws, 1 x FCM-FTM connector card		470137A		
	FTEB with 8 x rubber plugs, 4 screws		470156A		
	1 x FCM-FTM connector card, 8 x grounding isolators				
	FTFA with 2 x metal caps, 4 x screws, 1 x FCM-FTM connector card		470134A		
	FTHA with 2 x rubber plugs, 4 x screws, 1 x FCM-FTM connector card		471522A		
	FTIA with 7 x rubber plugs, 4 x screws, 1 x FCM-FTM connector card		471025A		
	FTIB with 7x rubber plugs, 4x screws, 1x FCM-FTM connector card		471720A		
	FTJA with 7 x rubber plugs, 4 x screws, 1 x FCM-FTM connector card		471248A		
	FTOA with 1 x rubber plug, 4 x screws, 1 x FCM-FTM connector card		470133A		
	1 x SDH SFP transceiver				
	FTFB with 3x metal caps, 2x rubber plugs, 4x screws, 1x FCM-FTM connector card		472036A		
	FTLB with 7x rubber plugs, 4x screws, 1x FCM-FTM connector card		471984A		
	Transmission cable deliveries	FTCA OD cable RJ48C - TQ-M/0 120ohm 5 m		470312A	
FTCB OD cable RJ48C 120ohm 15 m			470309A		
FTCD OD cable SMB-F/0 -BT43-F/0 75ohm 5 m			470313A		
FTCE OD cable SMB-F/0 75ohm 15 m			470310A		
FTCH OD cable LC SM 1310 15 m			470311A		
FTCJ OD cable TNC-F70-TNC M70 50 ohm 2.5 m			471391A		
FTCR OD cable RJ45 CAT5E 15 m			471408A		
FTCV OD cable RJ48C 120ohm 30M			471713A		
FTCX OD cable RJ48C 120ohm 50M			471714A		
FTCF OD cable SMB-F/0 75ohm 30M			471715A		
FTCG OD cable SMB-F/0 75ohm 50M			471716A		
FTCS OD cable RJ45 CAT5E 30M			471717A		
FTCT OD cable RJ45 CAT5E 50M			471718A		
FTCP OD cable MDR-68 100ohm 30M			471548A		
<b>Optional items</b>					
Plinth delivery	Mounting kit for floor, wall and pole	FMFA	470149A		
	2 x fixing plates for the casing				
Covers delivery	12 x M5x8 screws, 2 x M5x12 screws, 2 x M8 screws				
	3U front and back covers	FMCA	470239A		
	2 x maintenance straps				
Pole mounting kit delivery	Grounding cable		994815A		
	2 x external cable entries		085015A		
	Mounting brackets	VMPB	469978A		
FSEB delivery	4 x M10x120 bolts, 4 x M8x25 bolts, 4x M10x200 bolts,				
	4 x M10x300 bolts, 4 x washers				
	Flexi System External Alarm, 1 x D37 cable assembly, 3 x cable ties	FSEB	471421A		
	Flexi System External OVP	FSEC	471397A		
	Flexi Pole Kit	FPKA	471649A		
FPIA delivery	Flexi Pole Installation Kit	FPIA	471767A		

**Check list**

- Deliveries are complete.
- Equipment is not damaged.

## ② Clearances

### Minimum clearances

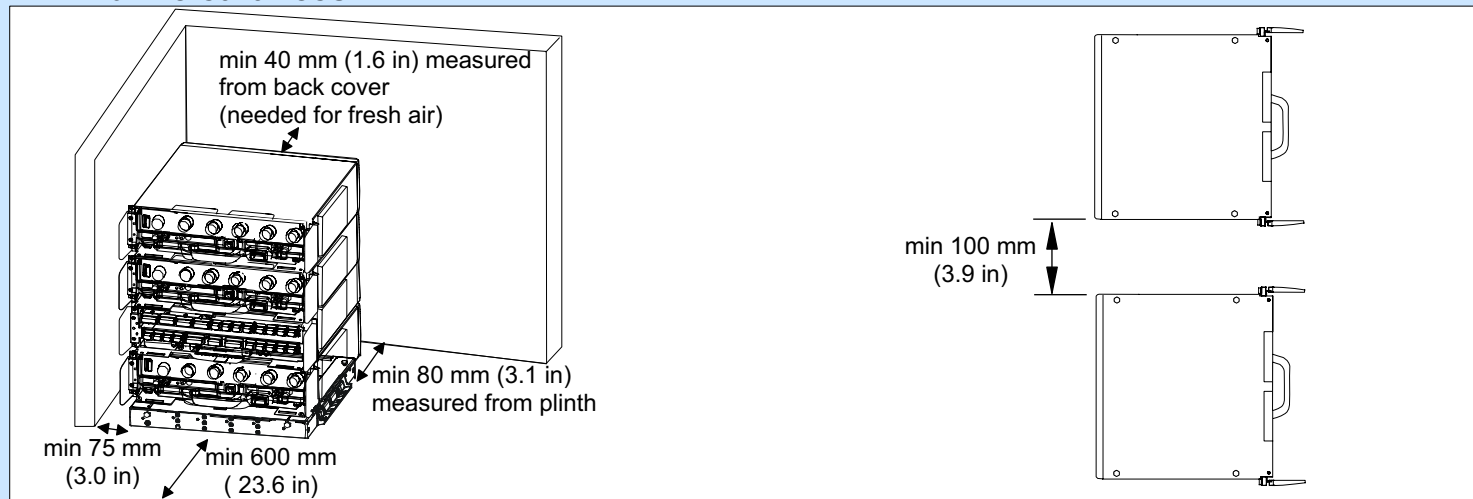

### Check list

- Site meets the minimum clearances.

## ③ Preparing modules for installation

### Back cover and cable entries

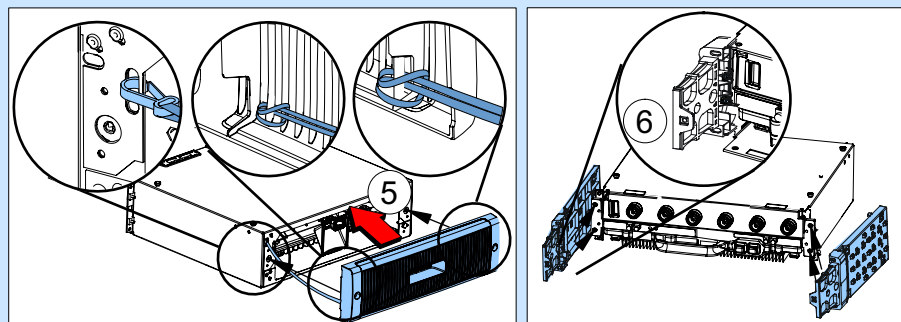

1. Thread the longer loop of the maintenance strap around the grill rib.
2. Route the end with the snap hook through the exposed loop and tighten the loop.
3. Engage the snap hook to the casing using the fixing points.
4. Install the back cover in the rear of the module.
5. Fix the back cover screws (Torx T25) and tighten to 2.5 Nm.
6. Fix the external cable entries to the sides of the casing.

### Check list

- Cable entries and back covers are installed.

## ④ Installing the plinth

### Plinth on the floor

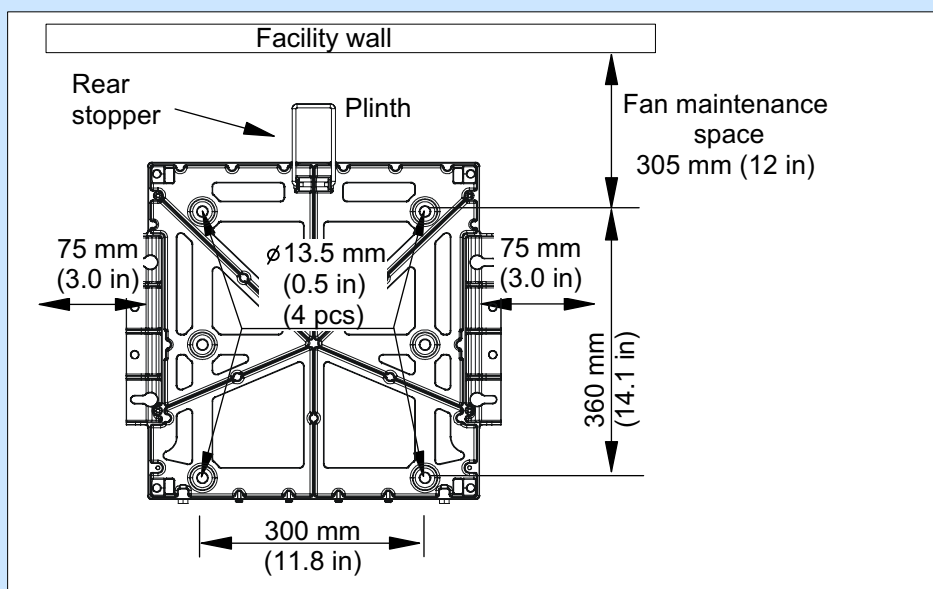

1. Check the clearances around the plinth.
2. Turn the rear stopper.
3. Place the plinth on the floor, grounding points facing forward.
4. Bolt on the floor with 4 bolts, 12 mm in diameter.

# ④ Installing the plinth (continued)

## Adapter mechanics

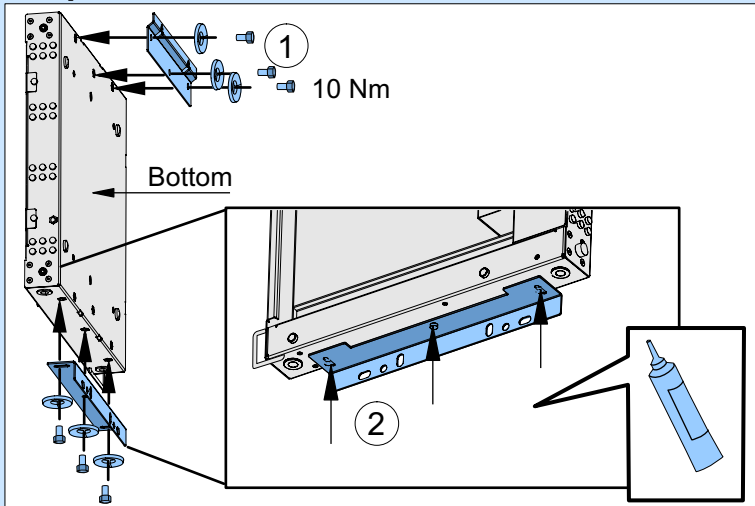

### NOTE:

The brackets of the adapter mechanics are installed on the plinth in wall and pole installations. They are only used with FMFA version 103 or older. In FMFA version 104, the adapter mechanics have been integrated to the plinth.

1. Fix the upper brackets on the plinth with 3 screws. Secure the screws with thread locking compound.
2. Fix the lower bracket on the plinth with 3 screws, **do not tighten yet**. Secure the screws with thread locking compound (for example Loctite 243). When the screws are left loose at this point, it allows the plinth to move slightly and prevents it to get twisted in the installation phase.

## Plinth on the wall

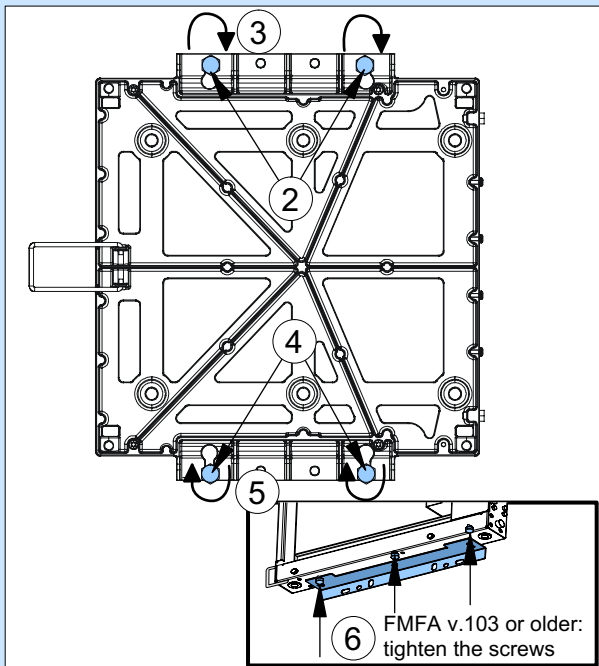
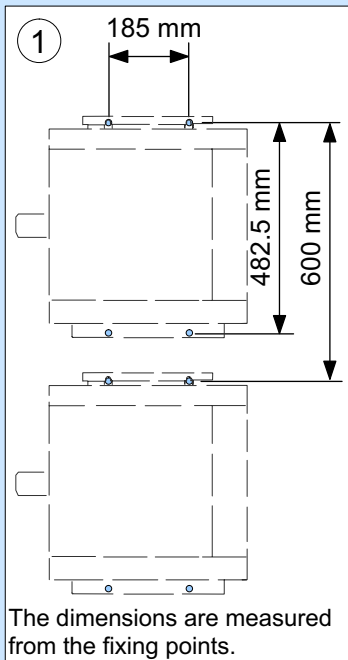

1. Mark screw locations according to the holes in adapter mechanics and drill holes.
2. Fix the mounting screws on the wall and mount the plinth.
3. Tighten the upper mounting screws.
4. Insert the lower mounting screws.
5. Tighten the lower mounting screws.
6. Tighten the adapter mechanics screws (FMFA v.103 or older only).
7. Ground the plinth. See section 4 for instructions.

**TIP: It is recommended to install the plinth with the front panel facing right.**

## Plinth on the pole

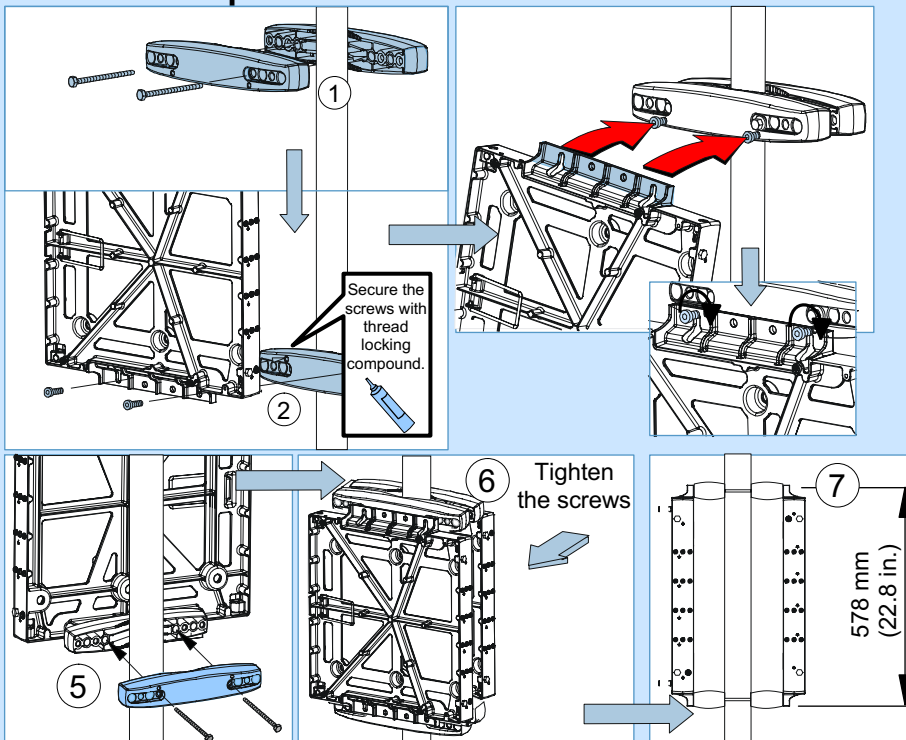

1. Fix the upper bracket on the pole and attach the mounting screws. The minimum diameter of the pole is 60 mm and maximum 300 mm.
2. Fix one half of the lower bracket on the plinth (FMFA v. 103 or older: on the adapter mechanics).
3. Lift the plinth on the pole.
4. Tighten the mounting screws.
5. Fix the counterpart of the lower bracket on the pole.
6. FMFA v. 103 or older: tighten the adapter mechanics screws.
7. If a second plinth is required, install it on the other side of the pole mounting bracket.
8. Ground the plinth. See section 4 for instructions.

## ④ Installing the plinth (continued)

### Check list

- Adapter mechanics are installed, secured with thread locking compound (for example Loctite 243) and tightened (for wall and pole installation).
- Plinth is installed according to instructions.
- Plinth is level and does not get twisted.
- Plinth is grounded.

## ⑤ Grounding principle of the BTS

### Grounding principle

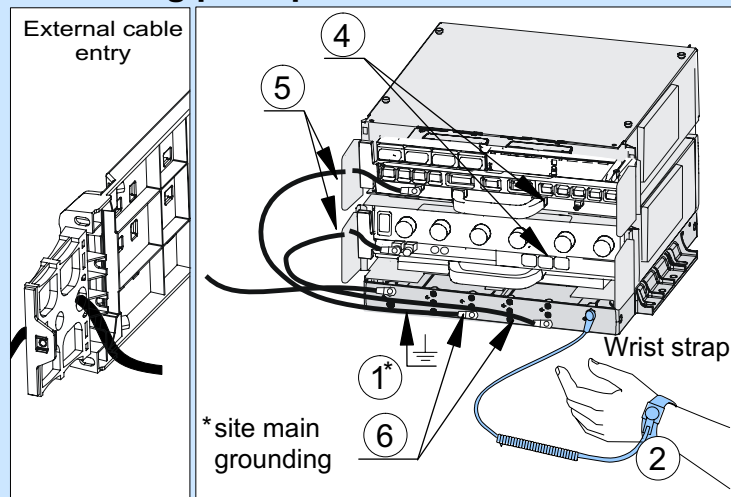

**NOTE: Do not chain grounding cables.**

1. Ground the plinth to the site main ground.
2. Connect the wrist strap.
3. Install the first module.
4. Connect the grounding cable to the module front panel.
5. Route the grounding cable through the cable entry.
6. Connect the other end of the cable to the plinth.
7. Repeat steps 3-6 for each module.
8. Fix the excess cables to the cable support plates with cable ties.

### Check list

- Antistatic wrist strap is used when handling modules.
- Module core is inside the casing.
- All modules are grounded.

## ⑥ Installing the transmission sub-module and power feed

### Installing the transmission sub-module

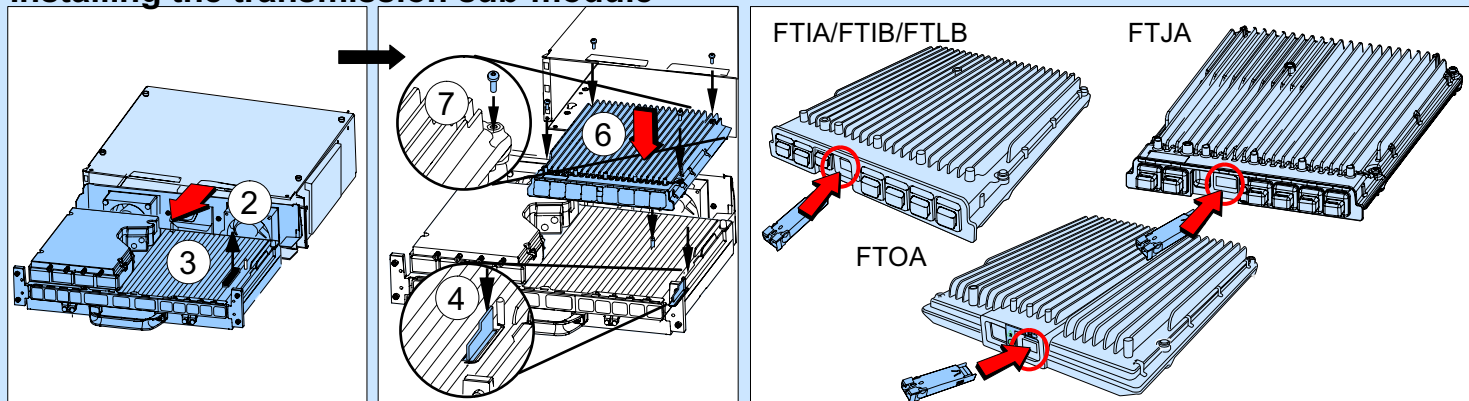

1. Loosen the System Module core fixing screws.
2. Pull out the module core.
3. Remove the rubber plug.
4. Insert the FCM-FTM connection card.
5. Check that the FCM-FTM connection card is straight.
6. Insert the transmission sub-module.
7. Fix the screws carefully. Tighten to 4.0 Nm.

8. If using the FTIA, FTIB, FTJA, FTOA or FTLB do one of the following:  
 FTIA/FTIB/FTLB: Insert a SFP Ethernet transceiver into the GE slot.  
 FTJA: Insert the SFP transceiver into the EIF1 slot.  
 FTQA: Insert the SFP SDH transceiver to the FTOA.

**NOTE: If your transmission sub-module is the FTIA, FTIB, FTJA or FTLB, the optical GE SFP is only required if this interface is used. The standard interface is the FE interface.**

### Check list

- Transmission sub-module is properly installed.

## 6 Installing the transmission sub-module and power feed (continued)

### DC power cable

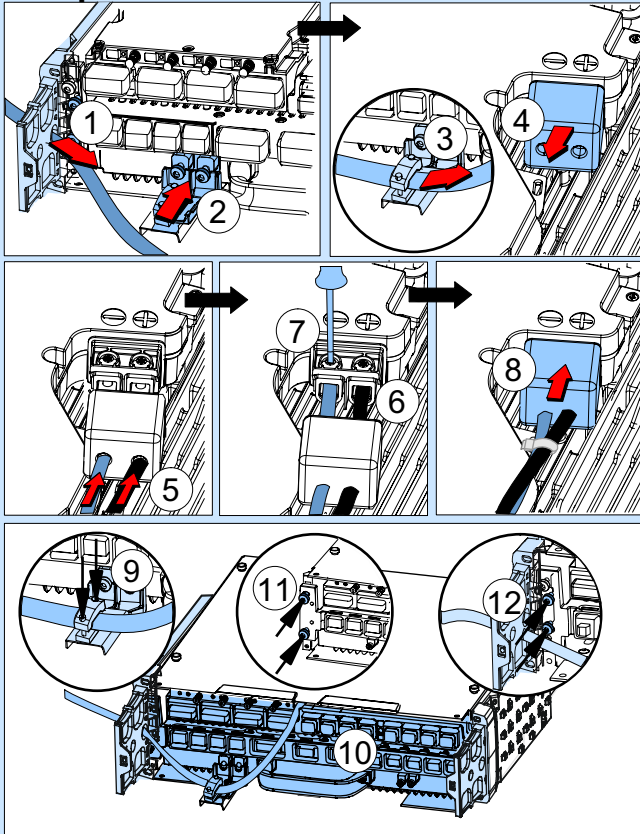

1. Route the DC power cable through the cable entry.
2. Install the cable clamp on the vacant grounding point of the module.
3. Route the cable through the cable clamp.
4. Remove the power connector IP gasket.
5. Thread the DC cable through the IP gasket.
6. Insert the DC power cable to the connector and make sure that the polarity is correct.
7. Tighten the connections to 5.0 Nm. Do not overtighten.
8. Cover the connector with the IP gasket and fix the cable to the cable tie point with a cable tie.
9. Tighten the cable clamp.
10. Re-insert the module core to the casing.
11. Tighten the module core screws.
12. Install the cable entries and tighten the screws.

#### NOTE:

**Do not switch on the site DC power feed yet.**

blue - black +

### Check list

- Make sure that the DC connector IP gasket is in place.
- DC power cable is connected and the cable clamp is in place.
- Module core is inside the casing, and cable entries are installed.

## 7 Installing the modules

### Principle of module installation

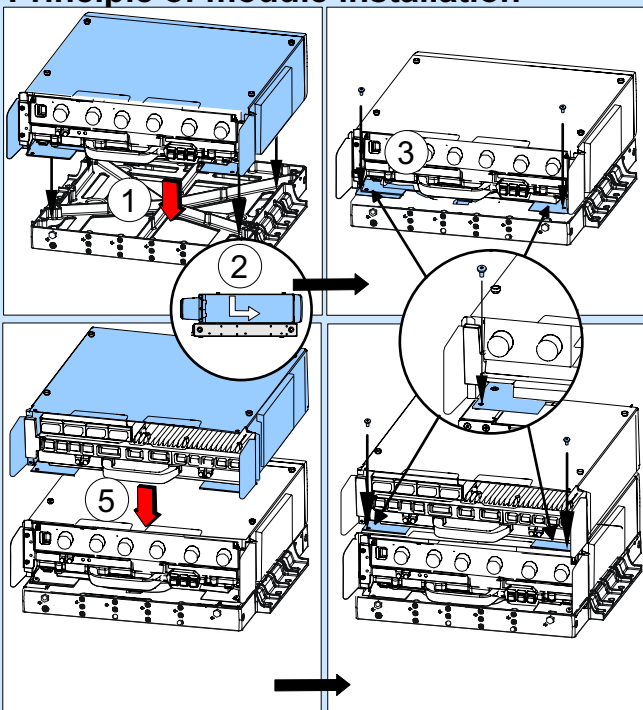

1. Line up the locating marks on the side of the module and align the holes on the first module bottom with the fixing studs on the plinth.
2. Push the module back until it stops.
3. Fix with two screws. In pole and wall installations, secure the screws with thread locking compound.
4. Connect the grounding cable to the module and the plinth.
5. Insert the second module and repeat steps 1-4.
6. Repeat the steps above for each module in your configuration.

**NOTE: In pole and wall installations, attach the fixing plate across the module casings and fix with six screws. Secure the screws with thread locking compound. See product documentation for further information.**

**NOTE: When installing modules into a third-party cabinet, module casings must always be used. Side trays or plates are required under each module in a third-party cabinet. See operating documentation for further information.**

# 7 Installing the modules (continued)

## Recommended installation order

**NOTE: Max. 5 modules for earthquake zone 4.  
Max. 9 modules for earthquake zone 2.**

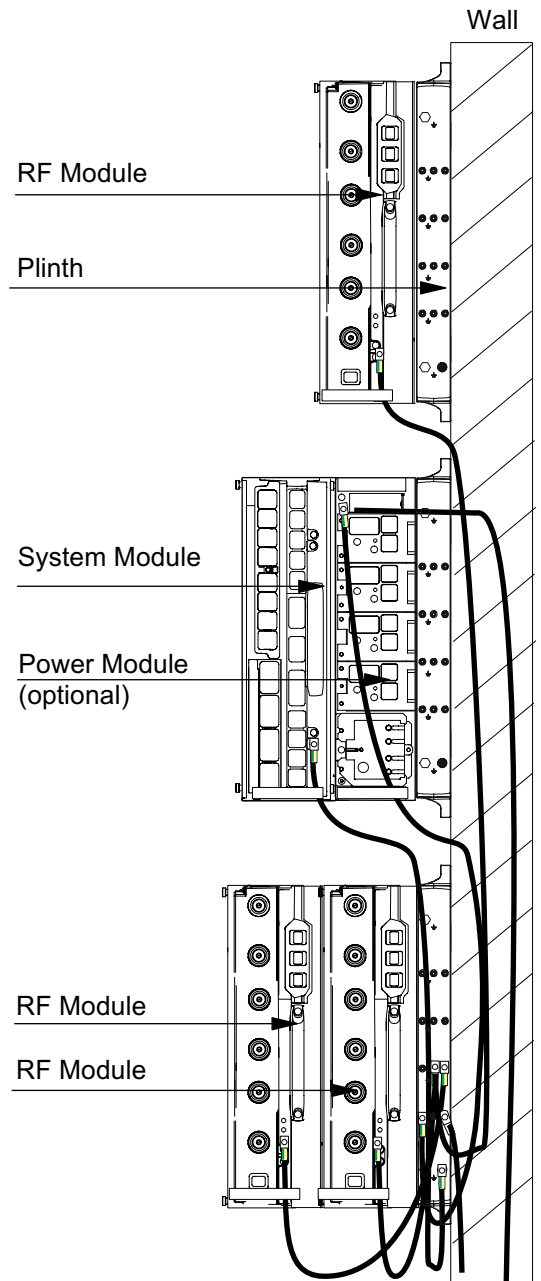
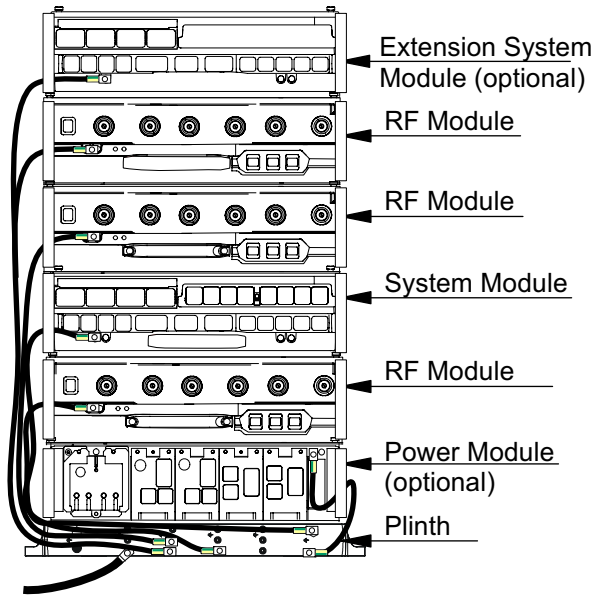

**NOTE: Maximum 2 modules per plinth.**

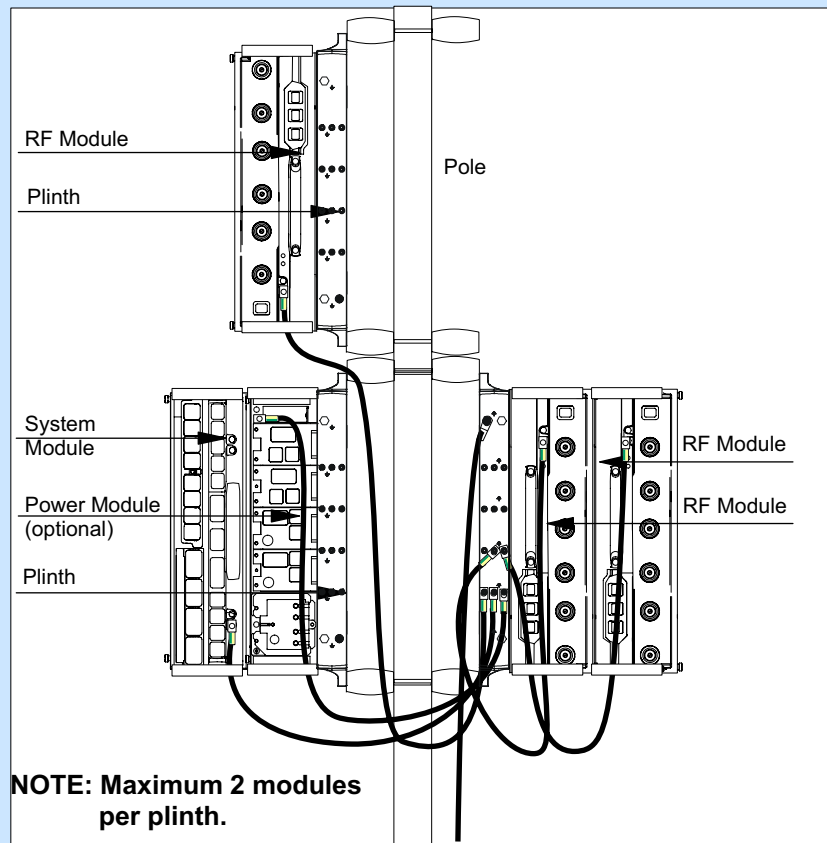

**NOTE: Maximum 2 modules per plinth.**

## Check list

- Modules are properly stacked.
- Modules are level.
- Modules are grounded.
- Module fixing screws are secured with thread locking compound and tightened.



## 8 Cabling

### Internal power cabling

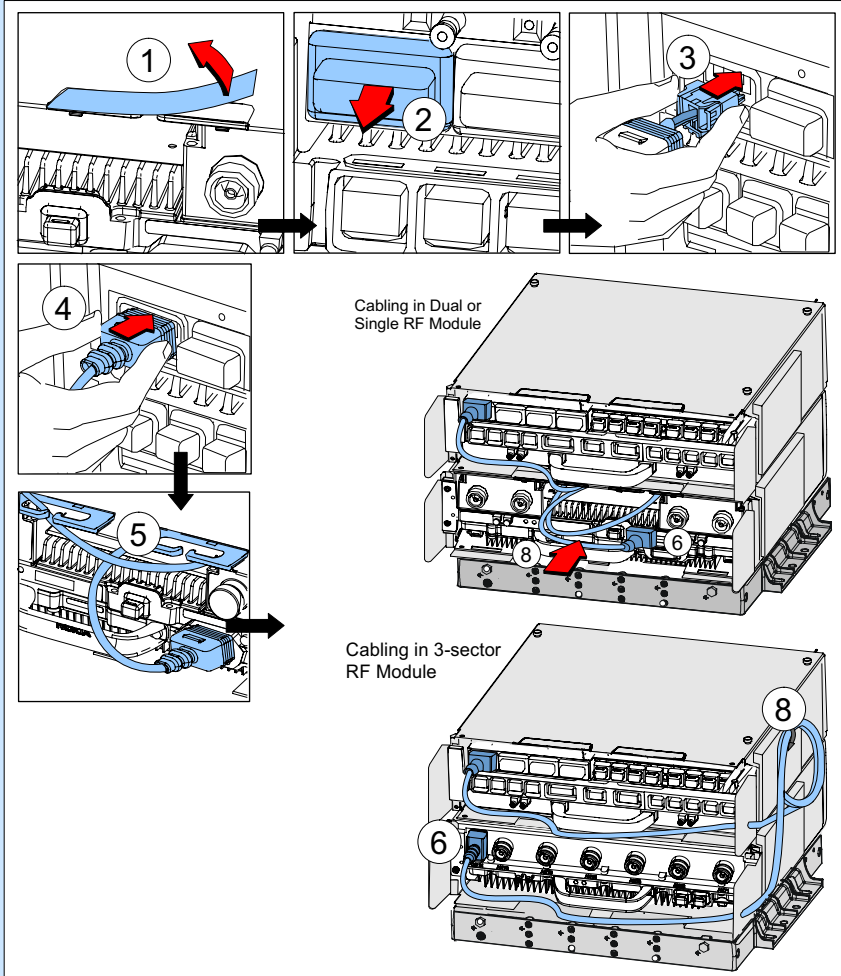

1. Remove the internal cable entry cover (Dual or Single RF Module only).
2. Remove connector seals from power cable connectors in modules.
3. Install the DC cable connector properly to the System Module.
4. Push the connector seal **firmly in place**.
5. Route the cable through the internal cable entry between System and RF Modules (Dual or Single RF Module only).
6. Connect the DC power cable to the RF Module.
7. Push the connector seal firmly in place.
8. Coil up the excess cable and do one of the following:
  - Dual or Single RF Module: push the cable in the RF Module cable slot
  - 3-sector RF Module: Fix the cable to the support plate on the casing with cable ties
9. Repeat for all RF Modules in the configuration.
10. Make sure that all the connector seals are **properly installed**.

### Antenna cabling

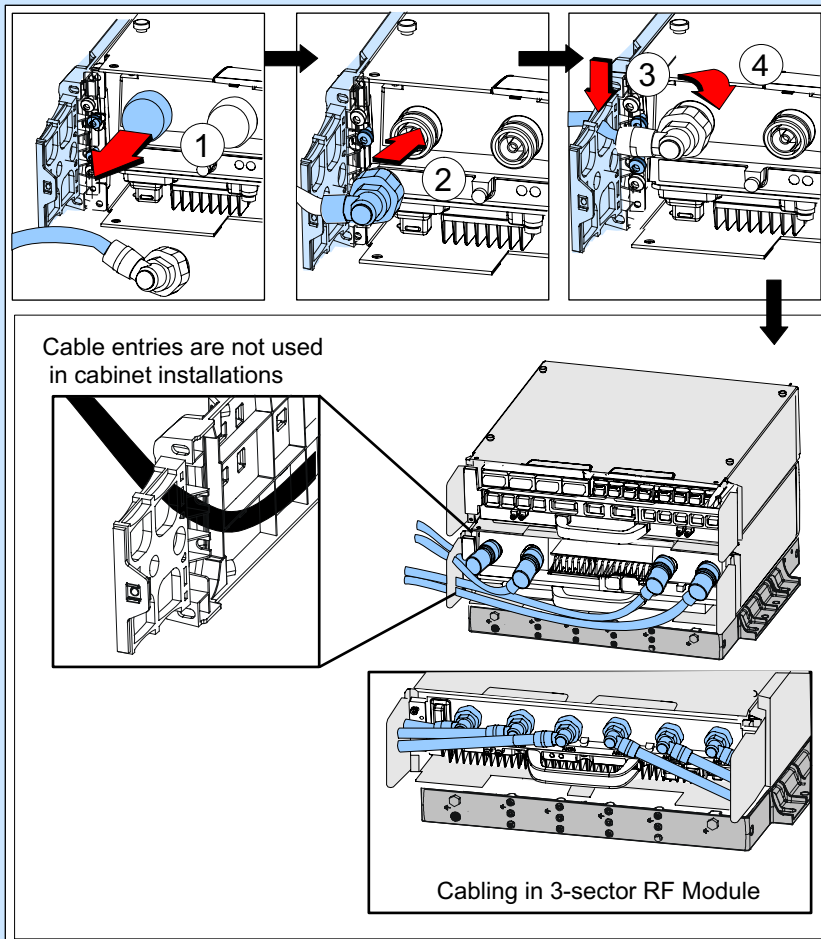

1. Remove the seal from the antenna connector in the RF Module.
2. Push the antenna jumper cable to the RF Module antenna connector.
3. Pierce the cable entry hole with a knife.
4. Push the antenna jumper cable to the cable entry.
5. Tighten the connector to 25 Nm.
6. Repeat for all the antenna cables in the configuration.

**NOTE:** In wall and pole installations, the recommended cable routing is through the lower cable entry.

## 8 Cabling (continued)

### Transmission cabling

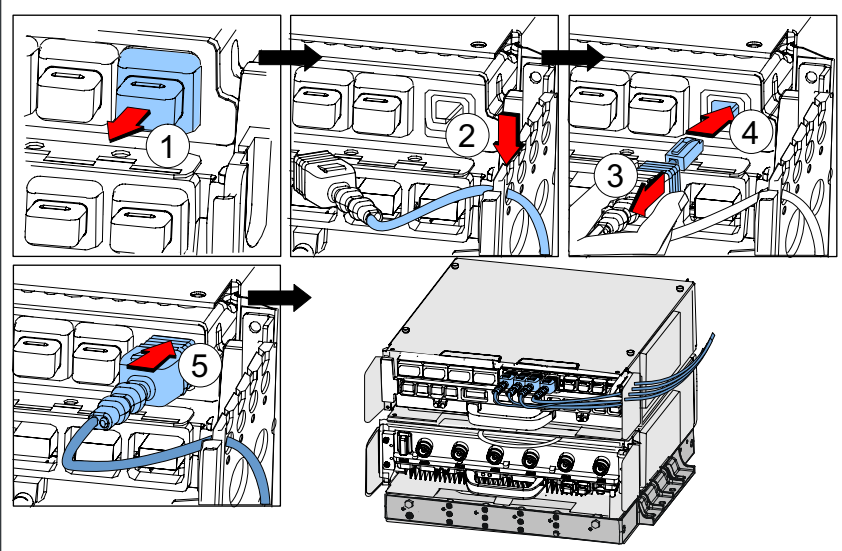

1. Remove the connector seal from the transmission sub-module connector.
2. Route the transmission cable through the cable entry.
3. Pull back the connector seal to uncover the connector.
4. Connect the cable to the transmission sub-module.
5. Push the cable connector seal **firmly in place**.
6. Make sure that all the connector seals are **properly installed**.
7. Fix the cables with the cable ties on the cable entry or cable support plate.
8. Repeat for all transmission cables in the configuration.

#### NOTE:

If using the FTOA or FTLB or the optical GE option of FTIA/FTIB/FTJA, an optical fibre is required.

If using the FTFA or FTFB, it is recommended to use the Flexbus jumper cable FTCJ 471391A for each Flexbus interface.

### Optical cabling

**CAUTION:** The optical cables are factory-bended to the left and, when connected, must always be routed to the left from the connector. Bending them to the right by force will break the cables.

**CAUTION:** Do not bend optical cables beyond the minimum radius of 70 mm.

**TIP:** If necessary, the optical cables can also be routed through the external cable entries. In that case, make a loop of the excess cable and fix it to the cable support plates with cable ties.

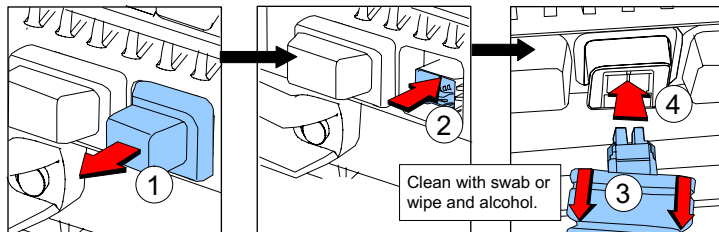

**CAUTION:** Make sure that the optical cable connectors have been cleaned.

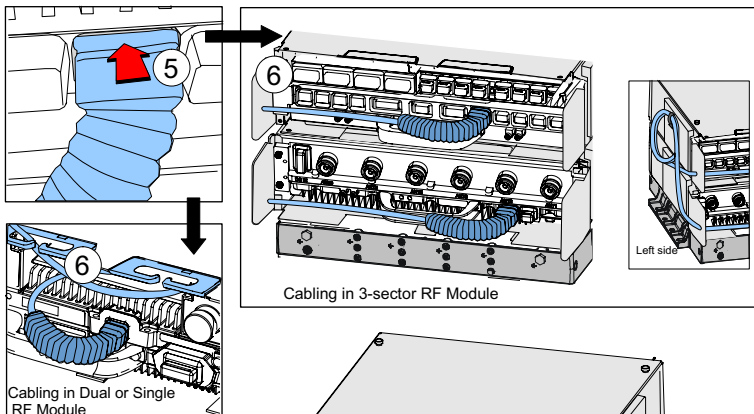

1. Remove the connector seal from the optical cable connector in the modules.
2. Push the optical transceiver in the System Module and remove the IP protective cap from the transceiver.
3. Pull back the connector seal to uncover the connector.
4. Remove the protective plugs, **clean the connector endfaces (see operating documentation)** and connect the cable to the System Module. Make sure it clicks into place.
5. Push the connector seal **firmly in place**.
6. Route the cable between System and RF Modules as follows:
  - Dual or Single RF Module: use the internal cable entry.
  - 3-sector RF Module: use an external cable entry and fix the cable to a cable support plate.
7. Coil up the excess cable and push it in the RF Module cable slot (Dual or Single RF Module only).
8. Push the optical transceiver in the RF Module and remove the IP protective cap from the transceiver.
9. Remove the protective plugs, clean the connectors and connect the optical cable to the RF Module. Make sure it clicks into place.
10. Push the connector seal **firmly in place**.
11. Repeat for all RF Modules in the configuration.
12. Make sure that all connector seals are **properly installed**.

## Check list

- All cables are connected according to the configuration.
- Optical cable connectors have been cleaned.
- BTS external cables or cables between the modules on separate plinths are routed via external cable entries.
- Connector seals are **firmly in place**.
- All cables are tied with cable ties or routed through cable clamps.

## 9 Powering up and commissioning the BTS

1. Power up the BTS and check the LEDs and fuses to ensure that all modules are powered.
2. Commission the BTS. See the *Commissioning Flexi Multiradio BTS* document for further information.

## 10 Front covers

### Front covers

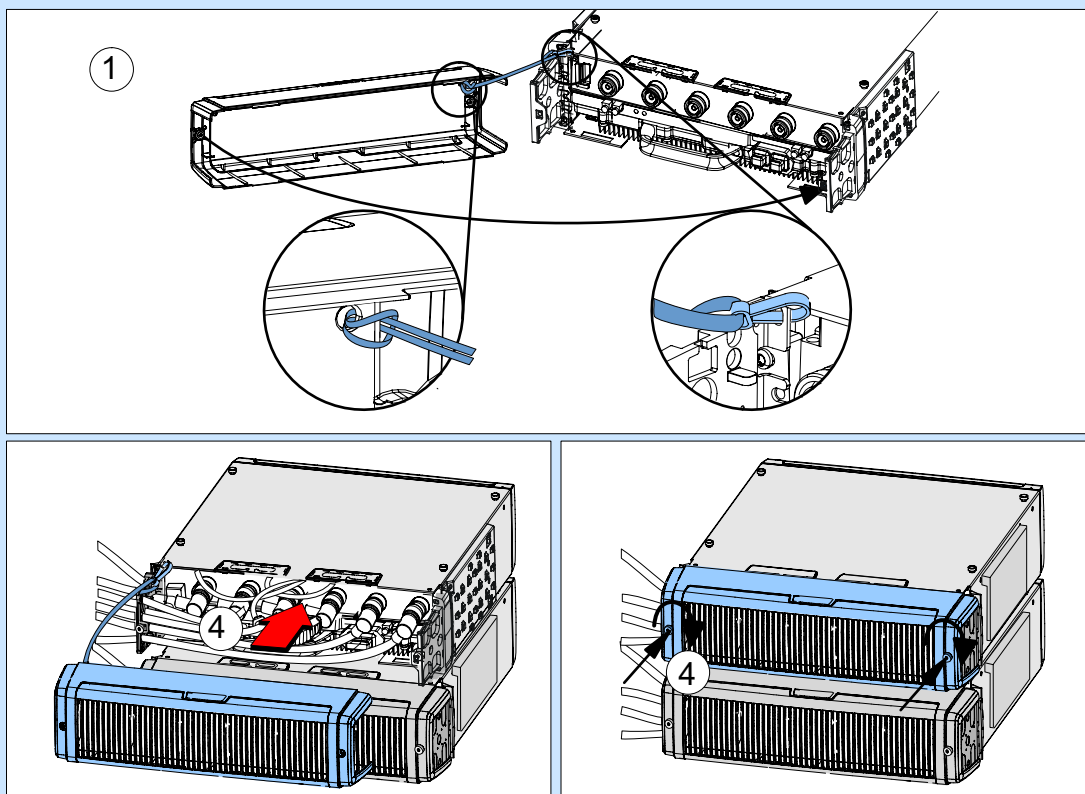

1. Thread the longer loop of the maintenance strap through the hole on the front cover.
2. Route the end with the snap hook through the exposed loop and tighten the loop.
3. Engage the hook to the hole on the external cable entry.
4. Install the front cover and tighten the screws (Torx 25) to 2.5 Nm.

## Check list

- Module front panel covers are installed.

## 11 Installation check list

**Perform these checks to make sure that the installation is complete:**

- Delivery is complete and undamaged.
- Minimum clearances are met.
- FMFA v. 103 or older: Adapter mechanics are installed (for wall and pole installations).
- Plinth is installed according to the instructions.
- Plinth is grounded.
- Transmission sub-module is installed according to the instructions.
- Power supply cable is connected.
- Modules are installed according to the instructions.
- Modules are grounded to the plinth.
- Cable entries are installed.
- Antenna cables are connected according to the configuration.
- Internal power cables are connected.
- Transmission cables are connected.
- Optical fibre cable connectors are cleaned and connected.
- Cables between the modules on the same plinth are routed via internal cable entries.
- BTS external cables or cables between the modules on separate plinths are routed via external cable entries.
- Cables are tied properly.
- Cable connector seals are **firmly in place**.
- Unused connectors are covered with IP seals.
- BTS is switched on and all modules are ready for commissioning.
- Module front covers are installed.
- Site is clean and installation completed.