

Installing and using the Expedience OSU-2510



Directions for connecting your
OSU to a computer or LAN and
obtaining high-speed Internet
access.

Expedience and LinkMonitor are trademarks of NextNet Wireless, Inc.

Other brand and product names may be registered trademarks or trademarks of their respective holders.

Part number: 104-0009-0001

©2002 NextNet Wireless, Inc. All rights reserved.

THE SPECIFICATIONS AND INFORMATION REGARDING THE PRODUCTS IN THIS GUIDE ARE SUBJECT TO CHANGE WITHOUT NOTICE. ALL STATEMENTS, INFORMATION, AND RECOMMENDATIONS IN THIS GUIDE ARE BELIEVED TO BE ACCURATE BUT ARE PRESENTED WITHOUT WARRANTY OF ANY KIND. USERS MUST TAKE FULL RESPONSIBILITY FOR THEIR APPLICATION OF ANY PRODUCT.

NOTWITHSTANDING ANY OTHER WARRANTY HEREIN, ALL DOCUMENT FILES AND SOFTWARE ARE PROVIDED "AS IS" WITH ALL FAULTS. NEXTNET WIRELESS DISCLAIMS ALL WARRANTIES, EXPRESSED OR IMPLIED, INCLUDING, WITHOUT LIMITATION, THOSE OF MERCHANTABILITY, FITNESS FOR A PARTICULAR PURPOSE AND NON-INFRINGEMENT OR ARISING FROM A COURSE OF DEALING, USAGE, OR TRADE PRACTICE.

IN NO EVENT SHALL NEXTNET WIRELESS OR ITS SUPPLIERS BE LIABLE FOR ANY INDIRECT, SPECIAL, CONSEQUENTIAL, OR INCIDENTAL DAMAGES, INCLUDING, WITHOUT LIMITATION, LOST PROFITS OR LOSS OF DAMAGE TO DATA ARISING OUT OF THE USE OR INABILITY TO USE THIS GUIDE, EVEN IF NEXTNET WIRELESS HAS BEEN ADVISED OF THE POSSIBILITY OF SUCH DAMAGES.

Contents

Welcome.....	1
Before you begin	1
Connecting your OSU to a computer ...	6
Installation overview	6
Setting up the computer to dynamically receive an IP address	6
Windows 95, Windows NT, Windows 98, Windows ME: Setting up the network connection	7
Windows 2000: Setting up the network connection	7
Installing the OSU	8
Attaching the NIM box to the outside of house	13
Cabling overview	16
Running cables through house's wall ...	17
Plugging cables into NIM box	17
Connecting ground wires	18
Plugging in power cord and RJ-45 cord	19
Finding the strongest service provider signal	19
Using the software-assisted method to find the strongest signal	21
Using the sound (auditory) method to find the strongest signal	22
Connecting to the Internet	22
Refreshing the OSU's connection	23
Windows users: Refreshing the connection	23
Non-Windows users: Refreshing the connection	23

Connecting the OSU to a network 24
FCC information25

Welcome

This document describes how to install and use your Expedience outdoor subscriber unit (OSU) to obtain wireless high-speed Internet access. You can connect your OSU to a computer or to a small office/home office (SOHO) local area network (LAN) through a hub, switch, or router.

BEFORE YOU BEGIN

- Make sure your computer is equipped with an Ethernet network interface card (NIC).
 - The Ethernet cable that is supplied with your OSU plugs into any standard Ethernet NIC. The NIC is not provided with the OSU, but you can purchase a NIC at most computer and electronics stores.
- Make sure you have purchased an RJ-45 cable. The length of this cable depends on where you plan to install the OSU on your house.
- Make sure you have purchased grounding wire of sufficient length to run between the OSU and a grounding pole. Also, you need to purchase grounding wire to run between the NIM box and the grounding rod.
 - The grounding wire you purchase should be an 8 gauge, solid aluminum wire.
 - It is recommended that the grounding rod you use be 8 foot copper. Note that every house has a grounding rod outside. If desired, you can install a rod into the ground outside the house.
- Find an appropriate location on the outside of the house to mount OSU.
 - To provide Internet service, your OSU communicates with a device on your service provider's communications tower. Your service provider must provide you with information about the nearest communications tower. For example, if the tower nearest to your home is north of your home, you will install the OSU on the north side of your house.
 - Mount the OSU in a high location on your home, such as under the eaves of your house.
- Find an appropriate location on the outside of your house to mount the NIM box.

- Locate the components shipped with your OSU device:
 - OSU device
 - Network interface manager (NIM) box
 - Software CD-ROM
 - Power cable and power supply box
 - Power/Ethernet cable
 - Lag bolt (6)
 - Hex screws (2)
 - Washers (2)
 - Split lock washers (2)
 - Double tab washer (2)

Figure 1 shows the OSU.



Figure 1: OSU

Figure 2 shows the network interface manager box.



Figure 2: NIM box

Table 1 lists the standard contents in your OSU package.

Table 1: OSU package components

Component	Part number
External OSU device (vertical)	123-0009-1001
External OSU device (horizontal)	123-0009-2001
Mounting bracket	350-0009-0010
1/4 X 2" Lag Bolt, Hex Hd, Grade 2 Galv.	594-9907-1464
1/4-20X.875 Bolt, Hex HD, SS	594-9909-1428
1/4 Split Lock Washer, SS	596-3003-1416
1/4 Flat Washer, SS	596-3004-1420
External OSU network interface box	123-0009-0055
Power cord	420-0010-1010
OSU Installation Guide	104-0009-0001
Ethernet cable	597-6020-0050
Installation software CD-ROM	110-0002-0001

Connecting your OSU to a computer

This section describes how to connect your OSU to a computer.

If you want to connect your OSU to a network device (such as a router or switch), refer to the section “Connecting the OSU to a network” on page 24, in this guide.

INSTALLATION OVERVIEW

The installation consists of the following major tasks, each of which is explained in greater detail in the sections that follow:

- 1 After ensuring your Ethernet NIC is installed properly, make sure your computer is set up to automatically obtain an IP address.
- 2 Attach the OSU mounting bracket to the outside of the house, then snap the OSU into the bracket.
- 3 Mount the NIM box to the outside of the house.
- 4 Run the power cable, the Power/Ethernet cable, and RJ-45 cable through a hole drilled through house’s wall.
- 5 Plug the cables into the NIM box.
- 6 Connect the grounding wires.
- 7 Back inside the house, plug in the power cord to standard household power.
- 8 Scan for the strongest service provider signal.
- 9 Connect to the Internet.

1

SETTING UP THE COMPUTER TO DYNAMICALLY RECEIVE AN IP ADDRESS

You must set up your computer so it can dynamically receive an IP address. Your service provider assigns your computer an IP address so that the Internet information you request can reach your computer.

- If you are running Windows 95, Windows NT, Windows 98 or Windows ME, go to “Windows 95, Windows NT, Windows 98, Windows ME: Setting up the network connection” on page 7.
- If you are running Windows 2000, go to “Windows 2000: Setting up the network connection” on page 7.
- If you don’t see your operating system listed here, check the system’s help file. Most explain how to set up a system to dynamically receive an IP address.

1A

WINDOWS 95, WINDOWS NT, WINDOWS 98, WINDOWS ME: SETTING UP THE NETWORK CONNECTION

- 1 From the **Start** menu, select **Settings**. Then select **Control Panel**.
- 2 In the window that appears, double click the **Network** icon.
- 3 Select the TCP/IP entry for the NIC.
- 4 Click **Properties**.
- 5 Select the **IP Address** tab.
- 6 Activate the **Obtain an IP Address automatically** radio button.
- 7 To close the windows, click **OK**.
- 8 Turn off your computer.

1B

WINDOWS 2000: SETTING UP THE NETWORK CONNECTION

- 1 From the **Start** menu, select **Settings**. Then select **Network and Dial-up Connections**.
- 2 Right click the connection you want to alter; that is, the name of your NIC. From the pop-up menu, select **Properties**.
- 3 The Local Area Connection Properties window appears. Select the **Internet Protocol (TCP/IP)** item. Click **Properties**.
- 4 In the window that appears, activate the **Obtain an IP address automatically** radio button. To close the window, click **OK**. On the remaining open window, click **OK** again.
- 5 Turn off your computer.

2

INSTALLING THE OSU

To install the OSU:

- 1 Attach the mounting bracket to the outside of the house.
- 2 Set the OSU inside the mounting bracket.
- 3 Tighten the lower mounting bolt to hold the OSU in place.

The following sections describe these steps in greater detail.

Attach the mounting bracket to the outside of the house

- 1 Make sure you install the OSU on the side of the house that has the greatest exposure to the communications tower of your service provider.

When you purchase your OSU, the service provider can provide you with information about tower locations that can provide the OSU with greatest signal exposure. This information will help you understand the best side of the house on which to mount the OSU.

- 2 Install the mounting bracket to the house. The bracket (like the OSU) must be installed vertically.
 - Drill the two top holes 1.25 inches apart. Drill the bottom hole 7 inches below the top hole.
 - If possible, drill one upper hole and its corresponding lower hole into a stud.
 - After the holes are drilled into the house, drive the screws through the holes on the mounting bracket and into the house.

Figure 3 illustrates the screws to use to attach the mounting bracket to the house.

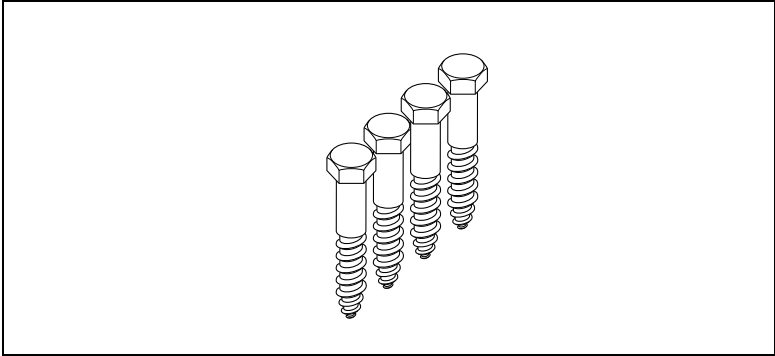

Figure 3: Screws to attach mounting bracket to house

Figure 4 provides a template (not to scale) for drilling holes into the side of the house.

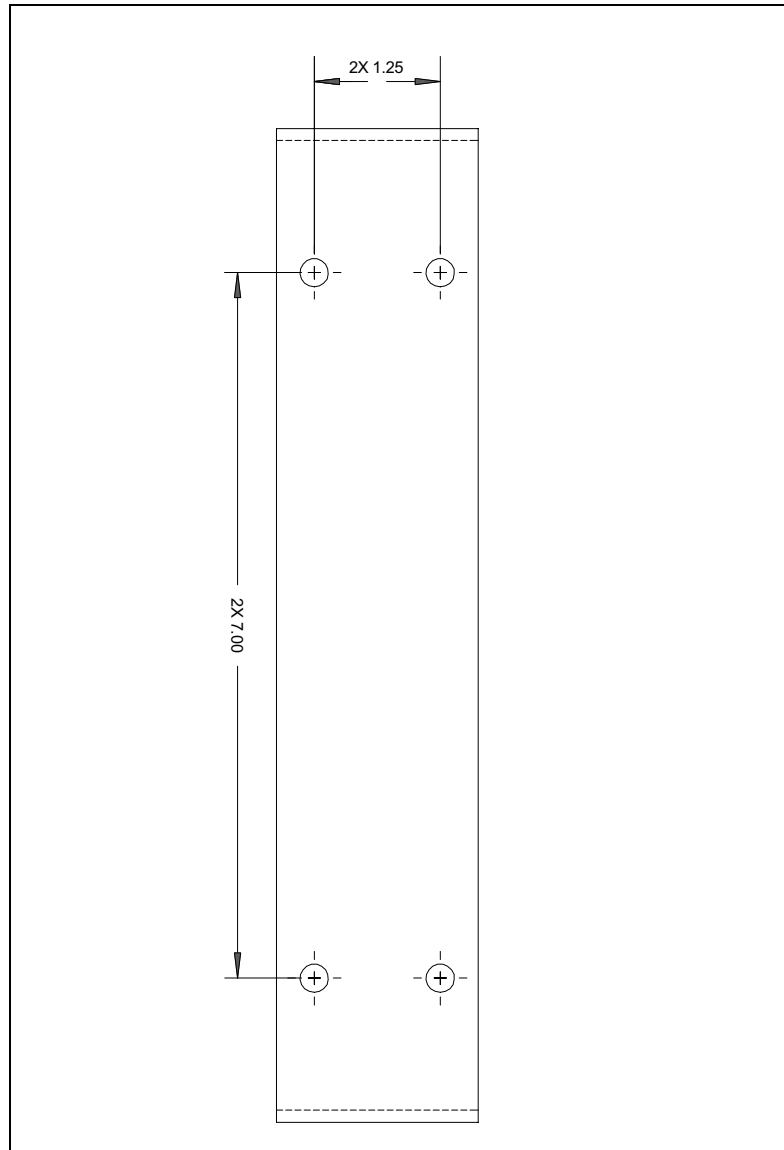

Figure 4: Mounting bracket template

Setting the OSU inside the mounting bracket

The OSU must be installed vertically. The OSU has a peg on top, and a peg on bottom. The upper and lower pegs snap into the mounting bracket's peg holes.

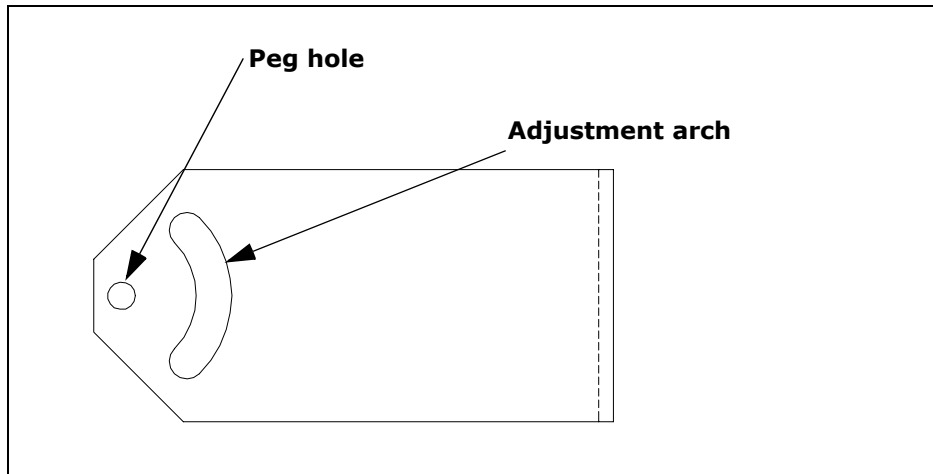

Figure 5: Adjustment arch and peg hole in mounting bracket

After you search for the strongest signal from the service provider, you insert a screw through the adjustment arch into the adjustment screw opening on the OSU.

Tighten this screw fully **only** after you have performed the tasks in step 8 "Finding the strongest service provider signal" on page 19.

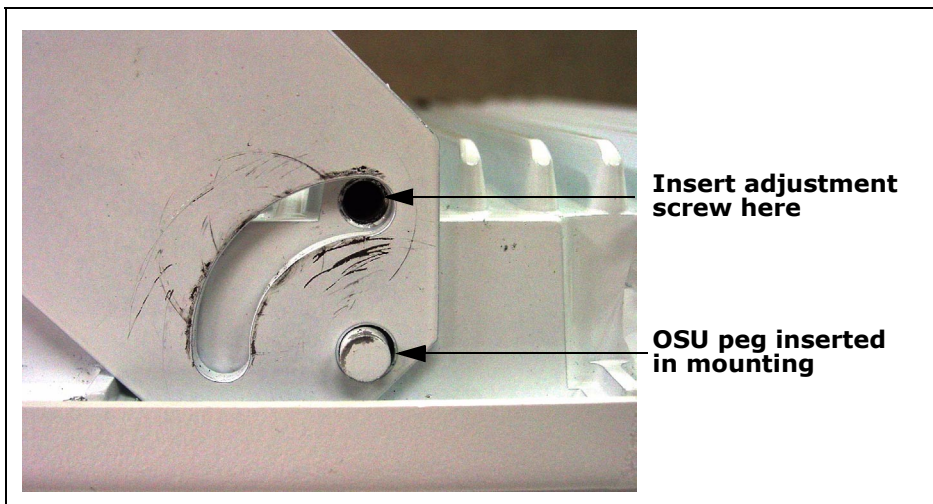

Figure 6: OSU peg in mounting bracket

You must install the OSU vertically. To install the OSU in the mounting bracket:

- 1 Make sure the bottom of the OSU faces the earth. This is the side of the OSU labelled with a sticker “MOUNT THIS SIDE DOWN”.



Figure 7: MOUNT THIS SIDE DOWN Sticker

- 2 On the bottom arm of the mounting bracket, snap the OSU’s peg into the peg hole.

To accommodate the height of the peg, you may need to bend the mounting bracket’s edge down slightly.

- 3 On the top arm of the mounting bracket, snap the OSU’s upper peg into the adjustment arch.

To accommodate the height of the peg, you may need to lift the mounting bracket’s edge up slightly.

Partially tightening adjustment screws to hold OSU in place

To make sure the OSU doesn't slip out of the mounting bracket, partially tighten the screws in the adjustment arch.

Because you still need to pivot the OSU along the adjustment arch—in order to find the strongest signal from the service provider—do not fully tighten the screws yet.

You will fully tighten the screws after completely. When the screws are fully tightened, the OSU will no longer move along the adjustment arch.

Figure 8 illustrates how the screw, split lock, flat washer and double-tab washer are put together.

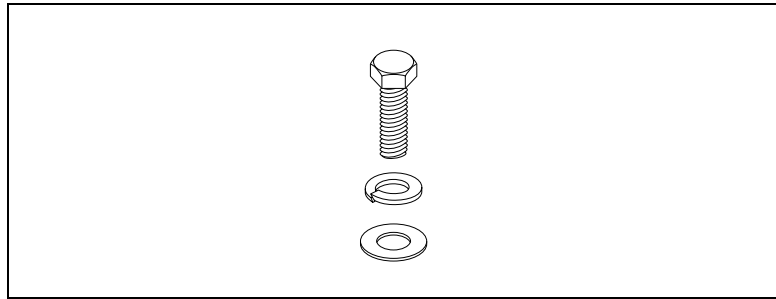

Figure 8: Mounting screw assembly

- 1 Assemble the screw, split lock washer, flat washer and double-tab washer as shown in Figure 8.
- 2 On the upper arm of the mounting bracket, insert the screw through the adjustment arch on the mounting bracket.
- 3 Partially tighten the screw on the OSU to hold it in place.
- 4 Because you still need to ground the OSU, do NOT fully tighten the bolt on the bottom of the OSU yet. You will tighten this bolt in step 6.

3

ATTACHING THE NIM BOX TO THE OUTSIDE OF HOUSE

To attach the NIM to the outside of your house:

- 1 Make sure the bottom of the NIM is facing the ground. A rubber grommet is installed on the bottom of the NIM.
- 2 The screws provided with the NIM are self-drilling.

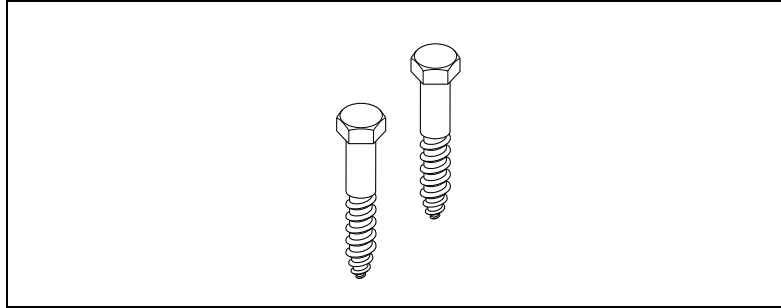

Figure 9: Screws to attach NIM box to house

- Drive the upper screw through the opening in the upper bracket and into the side of the house.
- Drive the lower screw through the opening in the lower bracket and into the side of the house.

Figure 10 illustrates where to drive the screws through the NIM box brackets and into the side of the house.

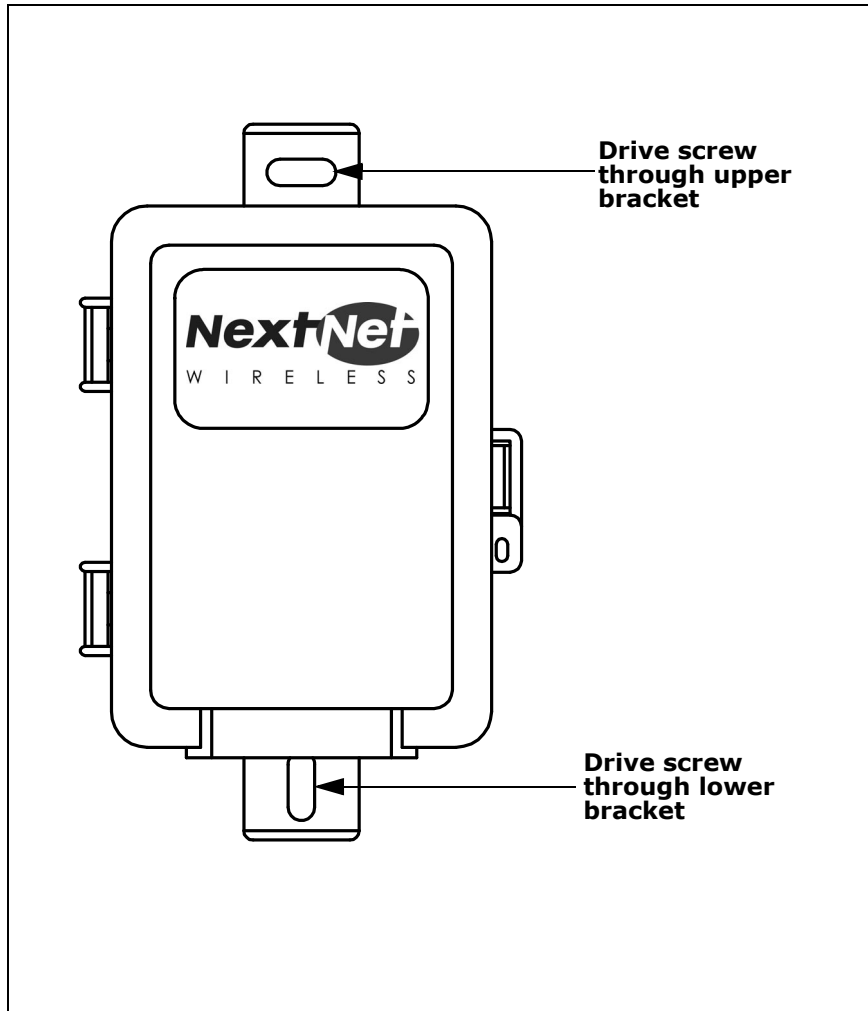

Figure 10: Mounting NIM to house's exterior

CABLING OVERVIEW

Figure 11 illustrates where ground cables, the RJ-45 cable, the power cord, and the Ethernet/power cable run.

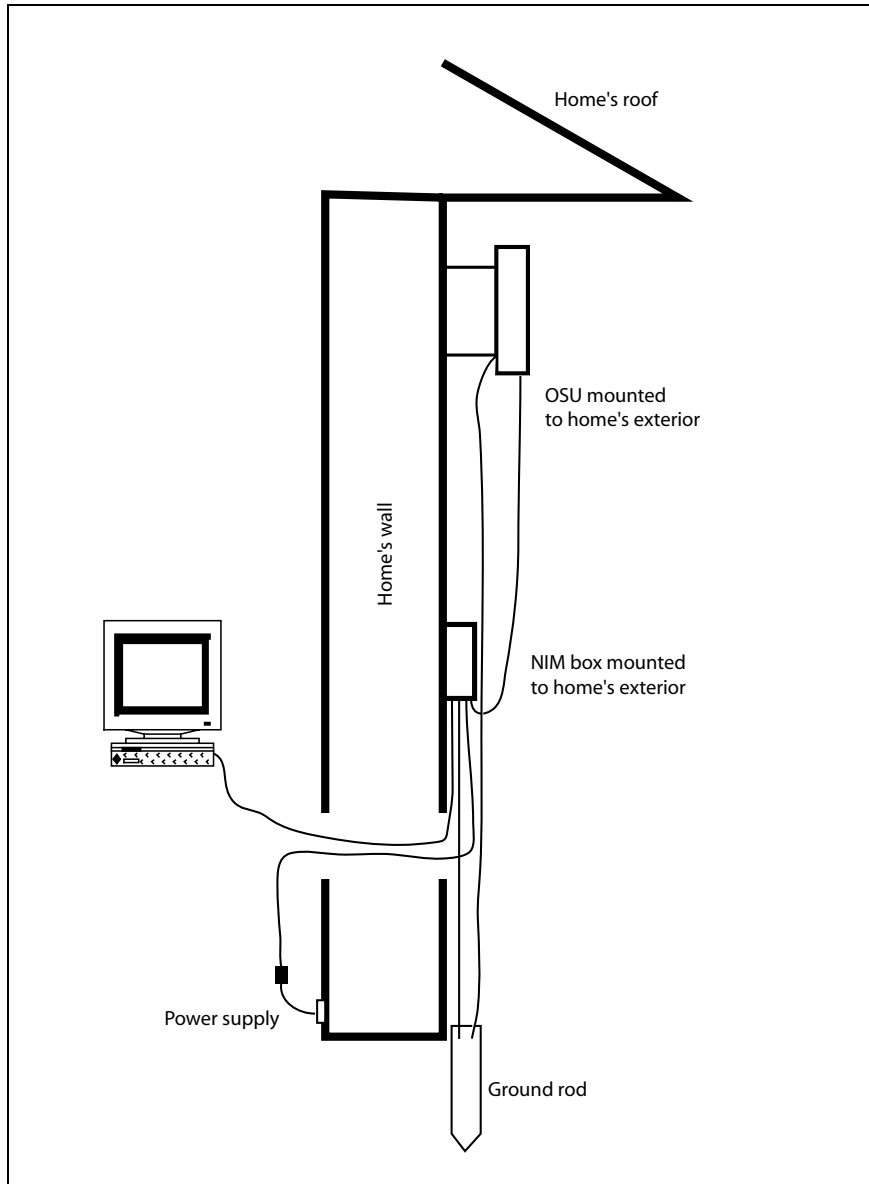

Figure 11: Connecting cables overview

4

RUNNING CABLES THROUGH HOUSE'S WALL

The hole through the house must be no further than 10 feet from the NIM box. This is because the power cord—from the power connector to the ferrite bead—must be inside the house.

- 1 Near the NIM box, drill a 3/4 inch hole through the house.
- 2 Draw the power/Ethernet cord through the hole.
- 3 Draw the power cable through the hole. Make sure that the length of the power cord, from power connector to the ferrite bead, are inside the house.

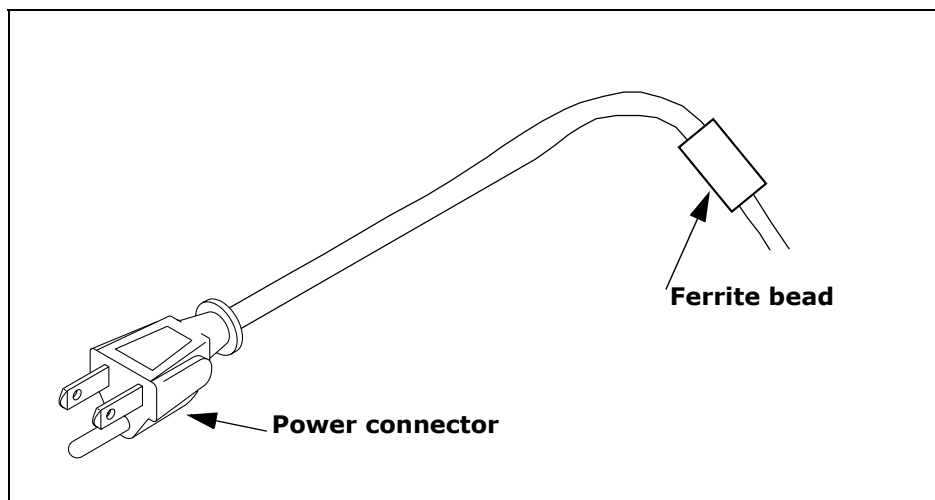

Figure 12: Length of power cable that must be inside house

- 4 Draw the RJ-45 cable through the hole.

5

PLUGGING CABLES INTO NIM BOX

You must connect cables into the NIM box in the order shown below. Failure to connect the cable in the proper order makes it difficult to run the cables through the rubber grommet on the bottom of the NIM box.

- 1 Connect the power/Ethernet cord. This is the cord that runs from the NIM box to the OSU device.
- 2 Plug in the RJ-45 cord.
- 3 Plug in the circular end of the power cord. This is the cord that runs from the power supply in your house to the NIM box.

Note: Do not plug in the power cord to the indoor power supply yet.

Figure 13 shows the cables and the ground wire connected inside the NIM box.

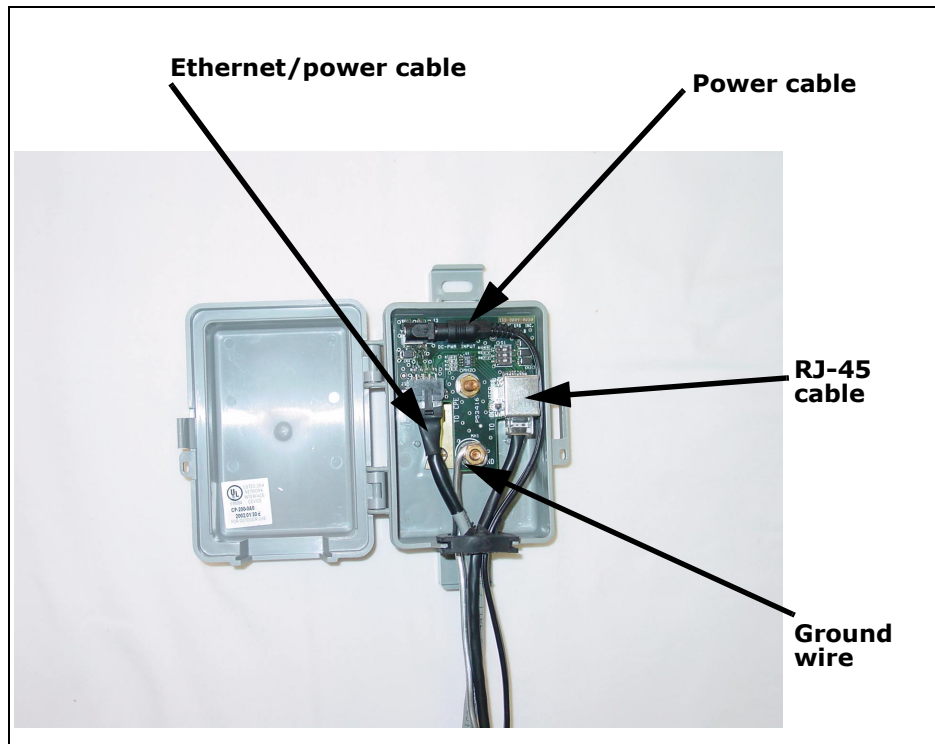

Figure 13: Cables and ground wire plugged into NIM box

6

CONNECTING GROUND WIRES

Both the OSU and the NIM box must be grounded to a grounding rod in the earth near your house. Make sure your grounding rod does not exceed a 50 feet maximum.

To ground the NIM box and the OSU:

- 1 Inside the NIM box, unscrew the hex nut labelled GND.
- 2 Insert one end of the grounding wire through the rubber grommet on the bottom of the NIM box.
- 3 Loop the grounding wire around the ground post.
- 4 Re-tighten the hex nut around the wire to hold it in place.
- 5 Connect the other end of the grounding wire to the grounding rod in the ground next to the house.

- 6 On the OSU device, loop the grounding wire around the bottom bolt that holds the OSU to the bracket.
- 7 Connect the other end of the grounding wire to the grounding rod in the ground next to the house.

7

PLUGGING IN POWER CORD AND RJ-45 CORD

- 1 The power cord uses standard household power. Plug the power cord in the power source.
- 2 Plug the RJ-45 cord into the NIC on your computer or switching device.

8

FINDING THE STRONGEST SERVICE PROVIDER SIGNAL

Your OSU is equipped with an internal antenna. To provide the best service, the OSU searches for the strongest signal transmitted by your service provider.

You can find the strongest signal from your service provider by using one of the following methods:

- Software-assisted method
- Sound (auditory) method

Both methods require you to install the LinkMonitor program

Installing the LinkMonitor program

- 1 Locate the software CD supplied with your OSU.
- 2 Insert the CD into your computer's CD drive. If the installation program does not start automatically, start it by clicking on the Setup.exe icon.

Follow the instructions in the dialog boxes to complete the installation of the LinkMonitor program.

- 3 After the software is installed, a blue RSU icon appears in your computer's system tray.

To run the LinkMonitor program, right click on the icon, and select **Open**.

LinkMonitor program's icon in system tray



Figure 14: Starting the LinkMonitor program

The Expedience LinkMonitor window appears (Figure 15).

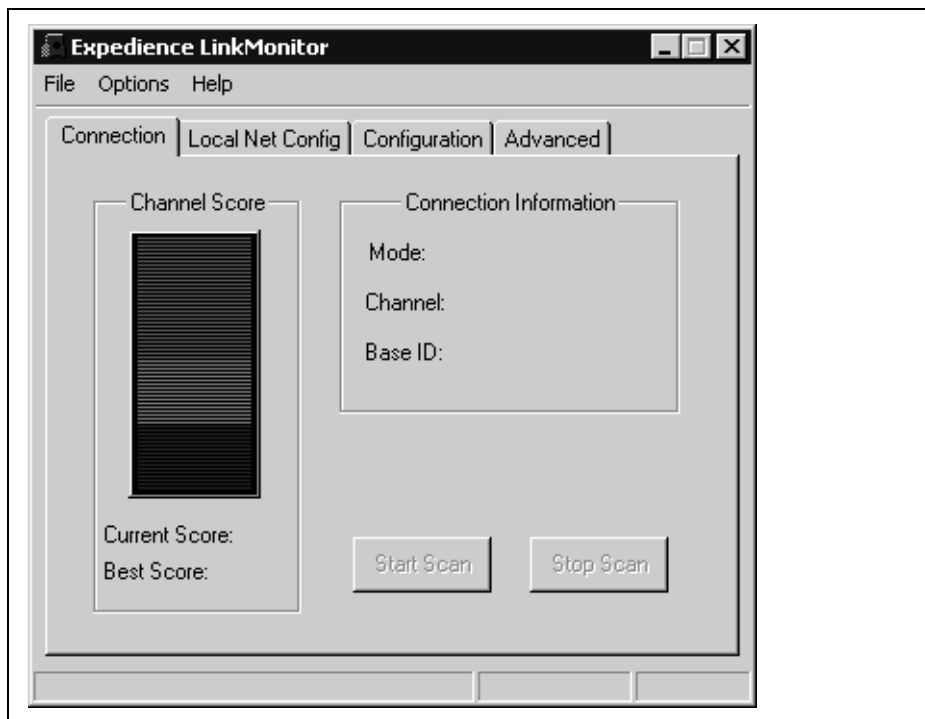

Figure 15: Expedience LinkMonitor window

8A

USING THE SOFTWARE-ASSISTED METHOD TO FIND THE STRONGEST SIGNAL

Note: It may be beneficial to have two people perform this procedure. One person will monitor software statistics inside the house. The other person will rotate the OSU outside the house.

To scan for the strongest signal from your service provider:

- 1 Install the LinkMonitor program as described in the section “Installing the LinkMonitor program” on page 19.
- 2 On the LinkMonitor window, click **Start Scan**.
- 3 Return to the OSU on the side of the house.
- 4 Rotate the OSU along the adjustment arch.
- 5 The LinkMonitor program searches for a signal from your service provider. In the **Channel Score** group, the strength of the signal received at the starting position is indicated in two ways:
 - The indicator bar shows varying levels of red, yellow, and green. Red indicates weak signal strength, yellow indicates moderate signal strength, and green indicates strong signal strength.
 - The **Current Score** field shows the signal strength. During this procedure, the program compares the Current Score to the **Best Score**. Best Score indicates the strongest signal the program has ever seen during the scanning procedure.
- 6 After about five seconds, point the front of the OSU to the right of the starting position.
- 7 Rotate the OSU along the arch again.

The software program determines and reports the strength of the signal that the OSU receives while the OSU is in its current orientation.
- 8 After about five seconds, note the strength of the signal received at its current position.
- 9 Rotate the OSU along the arch. The program determines and reports the strength of the signal that the OSU receives while the OSU is in its current orientation.

- 10 Remembering the strongest signal reported, re-orient the front of the OSU in the direction that the OSU was pointed when the strongest signal was found.
- 11 Tighten the screws fully that hold the OSU in place.
- 12 Return to the LinkMonitor program. Click **Stop Scan**.

8B

USING THE SOUND (AUDITORY) METHOD TO FIND THE STRONGEST SIGNAL

To use the sound (auditory) method to find the strongest signal:

- 1 Install the LinkMonitor program as described in the section “Installing the LinkMonitor program” on page 19.
- 2 On the LinkMonitor window, click **Start Scan**.
- 3 Return to the OSU outside. You should hear the OSU beeping.
- 4 The constancy/frequency of the beeps indicate the strength of the signal that the OSU detects.
- 5 Rotate the OSU along the adjustment arch, noting constancy/frequency of the beeps.
- 6 Point the OSU in the direction where the beeps are most constant.
- 7 Tighten the screws.

9

CONNECTING TO THE INTERNET

To connect to the Internet:

Start your Internet browser, and try to open a few Internet sites.

- If you can open numerous sites, enjoy your new, high-speed service.
- If you cannot open any sites—for example if your browser displays a message “This page cannot be displayed” for all the sites you tried to access—refresh the OSU’s connection, as described in the section “Refreshing the OSU’s connection” on page 23.

Refreshing the OSU's connection

When you refresh the OSU's connection, your service provider is assigning your computer a new IP address. You need to refresh your OSU's connection with your service provider when your Internet browser does not let you open any Internet sites.

WINDOWS USERS: REFRESHING THE CONNECTION

To refresh the connection:

- 1 Make sure you have installed the LinkMonitor program.
- 2 In the system tray, right click the blue RSU icon (Figure 14) and select **Open**.
- 3 In the window that appears, on the **Local Net Config** tab, click the **Renew IP Address** button.

NON-WINDOWS USERS: REFRESHING THE CONNECTION

If you do **not** run the Windows operating system, you can reboot your computer to refresh the connection. You may want to refer to your operating system's help files to determine if other methods exist to refresh the connection (that is, to find a method for refreshing the IP address).

Connecting the OSU to a network

Note: Use **only one** OSU on a network. Do **not** use multiple OSUs on the same network.

To directly connect the OSU to a computer, use the supplied Ethernet cable (also known as a straight-through cable).

However, to connect the OSU to a hub or switch, use an Ethernet cable appropriate for your network device. This might be a straight through or cross-over cable, depending on how your network device switches signals. When determining how to set up your network, remember that the OSU device operates as a hub or a bridge.

After connecting the OSU to the network device, power the OSU and scan for a service provider signal, as described in earlier sections of this guide.



FCC INFORMATION

NOTICE: This equipment has been tested and found to comply with the Radio Frequency Radiation Exposure Limits detailed below. A minimum of 20 centimeters (8 inches) separation between the RSU and the operator and all other persons should be maintained.

Radio Frequency Radiation Exposure Limits

Table 2 Limits for Maximum Permissible Exposure (MPE)

Frequency range (MHz)	Electric field strength (V/m)	Magnetic field strength (A/m)	Power density (mW/cm ²)	Averaging time (minutes)
(A) Limits for Occupational/Controlled Exposures				
0.3-3.0	614	1.63	*(100)	6
3.0-30	1842/f	4.89/f	*(900/f ²)	6
30-300	61.4	0.163	1.0	6
300-1500	—	—	f/300	6
1500-100,000	—	—	5	6
(B) Limits for General Population/Uncontrolled Exposure				
0.3-1.34	614	1.63	*(100)	30
1.34-30	824/f	2.19/f	*(180/f ²)	30
30-300	27.5	0.073	.2	30
300-1500	—	—	f/1500	30
1500-100,000	—	—	1.0	30

f = frequency in MHz

* = Plane-wave equivalent power density

NOTE 1 to Table 2: Occupational/controlled limits apply in situations in which persons are exposed as a consequence of their employment provided those persons are fully aware of the potential for exposure and can exercise control over their exposure.

Limits for occupational/controlled exposure also apply in situations when an individual is transient through a location where occupational/controlled limits apply provided he or she is made aware of the potential for exposure.

NOTE 2 to Table 2: General population/uncontrolled exposures apply in situations in which the general public may be exposed, or in which persons that are exposed as a consequence of their employment may not be fully aware of the potential for exposure or cannot exercise control over their exposure.

Note: This equipment has been tested and found to comply with the limits for a Class B digital device, pursuant to part 15 of the FCC rules. These limits are designed to provide reasonable protection against harmful interference when the equipment is operated in a commercial environment. This equipment generates, uses, and can radiate radio-frequency energy, and, if not installed and used in accordance with the installation manual, may cause harmful interference to radio communications. Operation of this equipment in a residential area is likely to cause harmful interference, in which case users will be required to correct the interference at their own expense.

Table 3 Technical information

Transmitting power	Up to 2 watts
Operating voltage	120 VAC nominal
Frequency band	2500 - 2686 MHz TX/RX
Frequency stability	±10 ppm
Number of channels	31
Channel bandwidth	6 MHz
Modulation	Orthogonal frequency division multiplex
Transmission	Time division duplex/time division multiplex

Index

C

computer
NIC requirement 1
cross-over cable 24

I

IP address (host computer)
refreshing 23
setting up for dynamic assignment 6

L

LAN
connecting to OSU 24

N

network device
connecting to OSU 24
NIC requirement 1

O

OSU
connecting to network 24

P

part numbers list 5

R

router
connecting to OSU 24
RSU
choosing installation location 1
min. separation distance of
equipment and persons 25
package components 5

S

switch
connecting to OSU 24

