

SIEMENS

Installation

Base Transceiver Station Equipment

IMN:BTSE BS11 DRAFT

A30808-X3247-B359-2-7631

CAUTION

Note: This equipment has been tested and found to comply with the limits for a Class A digital device, pursuant to part 15 of the FCC Rules. These limits are designed to provide reasonable protection against harmful interference when the equipment is operated in a commercial environment. This equipment generates, uses, and can radiate radio frequency energy and, if not installed and used in accordance with the instruction manual, may cause harmful interference to radio communications. Operation of this equipment in a residential area is likely to cause harmful interference in which case the user will be required to correct the interference at his own expense.

Siemens AG 1998

Issued by the Public Communication Networks Group
Hofmannstraße 51, D-81359 München

Technical modifications possible

Technical specifications and features are binding only
insofar as they are specifically and expressly agreed
upon in a written contract.

Issues

Note on the change indication:

The change indications for a title marked as issue 1 refer to the previous version. The change indications for a title with an issue greater than 1 refer to the preceding issue.

Change indications (Ind.):

N = new

G = modified;

0 = deleted;

Document	Title	Page(s)	Issue/Ind.
Register			
IMN/ITMN:BTSE	IS	1...87	2 N

This document consists of a total of 87 pages.

Contents

1.	General.....	9
1.1.	Purpose of the Manual	9
1.2.	Overview Base Transceiver Station.....	9
1.2.1.	Main Tasks	9
1.2.2.	Standard Technical Features	10
2.	BS-11i Installation	11
2.1.	Site Requirements.....	11
2.2.	Site Configuration.....	12
2.3.	Construction View of the BTSE	13
2.4.	Equipment Delivery	14
2.4.1.	Preliminary Checks	14
2.4.2.	BTSE Unpacking.....	14
2.4.3.	Installation Kit Unpacking	15
2.4.4.	Spare parts for field maintenance.....	15
2.5.	Wall Mounting of the BTSE	16
2.5.1.	Installation Tools	16
2.5.2.	Ancillary Material.....	16
2.5.3.	BTSE Installation Procedure	16
2.5.4.	Antenna mounting.....	19
2.5.5.	Solar shield mounting.....	19
2.6.	Pole Mounting of the BTSE	22
2.6.1.	Installation Tools	22
2.6.2.	Ancillary Material.....	22
2.6.3.	BTSE Installation Procedure	22
2.6.4.	Antenna mounting.....	28
2.6.5.	Solar shield mounting.....	28
2.7.	External Cabling Activities	28
2.7.1.	Ground and Power Supply Connections	30
2.7.2.	Abis Interface - PCM 30 Link Equipment	32
2.7.3.	Connection to the J01 connector	36
2.8.	Post Installation Notes	36
3.	BS-11e Installation	39
3.1.	Site Requirements.....	39
3.2.	Site Configuration.....	40
3.3.	Construction View of the BTSE	41
3.4.	Equipment Delivery	42
3.4.1.	Preliminary Checks	43
3.4.2.	BTSE Unpacking.....	43
3.4.3.	Installation Kit Unpacking	43
3.4.4.	Spare parts for field maintenance.....	44
3.5.	Wall Mounting of the BTSE	44
3.5.1.	Installation Tools	44
3.5.2.	Ancillary Material.....	45
3.5.3.	BTSE Installation Procedure	45
3.5.4.	Dummy panel mounting	47
3.5.5.	Solar shield mounting.....	47
3.6.	Pole Mounting of the BTSE	49
3.6.1.	Installation Tools	49
3.6.2.	Ancillary Material.....	49

3.6.3.	BTSE Installation Procedure	49
3.6.4.	Solar shield mounting	55
3.7.	External Cabling Activities	55
3.7.1.	Ground and Power Supply Connections	57
3.7.2.	Abis Interface - PCM 30 Link Equipment	59
3.7.3.	Connection to the J01 connector	63
3.8.	Antenna Connections	63
3.8.1.	Antenna System Fulmination Protection	65
3.8.2.	Antivandalism Protection	65
3.8.3.	Cable Down-Leads	65
3.8.4.	Interconnection Plate	65
3.9.	Post Installation Notes	67
4.	Appendix.....	69
4.1.	AC Main Connector.....	69
4.1.1.	Connector type.....	69
4.1.2.	General view.....	69
4.1.3.	Dimensions (mm).....	69
4.1.4.	Technical characteristics	69
4.1.5.	Materials	70
4.1.6.	Pinning of Power Supply Socket.....	70
4.1.7.	Mounting of the cable-Movable socket.....	70
4.2.	PCM Connector	71
4.2.1.	Straight connector type	71
4.2.2.	General view	71
4.2.3.	Dimensions (mm).....	72
4.2.4.	General view.....	72
4.2.5.	Mounting of cable on connector.....	72
4.2.6.	Connections	73
4.3.	RF Connector Type N N15015 C4 GN-1	74
4.3.1.	Connector type.....	74
4.3.2.	General view.....	75
4.3.3.	Dimensions (mm).....	75
4.3.4.	Technical characteristics	75
4.3.5.	Materials	76
4.4.	RF Connector Type N N15022 C4 G-1	76
4.4.1.	Connector type.....	76
4.4.2.	General view.....	76
4.4.3.	Dimensions (mm).....	76
4.4.4.	Technical characteristics	77
4.4.5.	Materials	77
4.5.	RF Connector Type N for ½" cable.....	77
4.5.1.	Connector type.....	77
4.5.2.	General view.....	78
4.5.3.	Dimensions (mm).....	78
4.5.4.	Technical characteristics	78
4.5.5.	Materials	79
4.6.	Alarm Connector	79
4.6.1.	Connector type.....	79
4.6.2.	General view.....	79
4.6.3.	Pinning of J01 connector.....	80
4.6.4.	Mounting of the straight cable socket	80
4.7.	Coaxial Cables.....	81
4.7.1.	½" cable (OTE code: 22580000175).....	81

4.7.2.	Cable RT 5020.....	81
4.8.	Alarm Cable (OTE Code 22401200528)	82
4.9.	Radio Frequency Cables Assembly.....	83
4.9.1	½" Cable Assembly to type "N" connectors (dimensions in mm)	83
4.9.2	RT 5020 Cable Assembly.....	84
4.10.	LMT Cable for BTSE	85
4.10.1.	Composition of LMT Cable.....	85
4.10.2.	General view.....	86
5.	Abbreviations	87

Illustrations

Fig. 1.1.	BTSE in the SBS architecture	10
Fig. 2.1.	Site Configuration.....	12
Fig. 2.2.	BTSE: Location of boards and modules (BiTRX)	13
Fig. 2.3.	Holes for wall mounting	17
Fig. 2.4.	BTSE: Wall mounting frame	18
Fig. 2.6.	Connector panel cover	21
Fig. 2.7.	Antenna connections (BiTRX internal antenna).....	21
Fig. 2.8.	BTSE: Pole mounting frame without tilting mechanism	24
Fig. 2.9.	Buckle slided on band	25
Fig. 2.10.	Band around pole.....	25
Fig. 2.11.	Apply tension	26
Fig. 2.12.	Tightening	26
Fig. 2.13.	Rolling tool	27
Fig. 2.14.	Cutting the band.....	27
Fig. 2.15.	Removing tool	27
Fig. 2.16.	Hammering buckle ears	28
Fig. 2.17.	Connection panel	30
Fig. 2.18.	Ground and power supply connections (example)	32
Fig. 2.19.	STAR/MULTIDROP Configuration.....	33
Fig. 2.20.	Multidrop configuration Functions of Y01 ÷ Y04 connectors.....	34
Fig. 2.21.	Star configuration Functions of Y01 ÷ Y04 connectors	35
Fig. 2.22.	Connection Panel.....	35
Fig. 2.23.	Y01 ÷ Y04, J01 and J02 connectors.....	36
Fig. 3.1.	Site Configuration.....	41
Fig. 3.2.	BTSE: Location of boards and modules (BiTRX)	42
Fig. 3.3.	Holes for wall mounting	46
Fig. 3.4.	BTSE: Wall mounting frame	47
Fig. 3.5.	Solar shield mounting	48
Fig. 3.6.	BTSE: Pole mounting frame.....	51
Fig. 3.7.	Buckle slided on band	52
Fig. 3.8.	Band around pole.....	52
Fig. 3.9.	Apply tension	53
Fig. 3.10.	Tightening	53
Fig. 3.11.	Rolling tool	54
Fig. 3.12.	Cutting the band.....	54
Fig. 3.13.	Removing tool	54
Fig. 3.14.	Hammering buckle ears	55
Fig. 3.15.	Connection panel	57
Fig. 3.16.	Ground and power supply connections (example)	59
Fig. 3.17.	STAR/MULTIDROP Configuration.....	60
Fig. 3.18.	Multidrop configuration Functions of Y01 ÷ Y04 connectors.....	61
Fig. 3.19.	Star configuration Functions of Y01 ÷ Y04 connectors	62
Fig. 3.20.	Connection Panel.....	62
Fig. 3.21.	Y01 ÷ Y04, J01 and J02 connectors.....	63
Fig. 3.22.	Antenna Cabling.....	64
Fig. 3.23.	Cable Pass Plate	66
Fig. 3.24.	Interconnection Plate	67

1. General

The CE declaration of conformity for the product will be fulfilled if the setup and cabling is undertaken in accordance with the specification in the manual and the documentation listed there, such as mounting instructions, cable lists etc. Where necessary, account should be taken of project-specific documentation. Deviations from the specifications or independent changes during setup, such as use of cable types with lower screening values, for example, can lead to the CE requirements being violated. In such cases the CE declaration of conformity is invalidated and the responsibility passes to the person who has caused the deviations.

1.1. Purpose of the Manual

This document is intended to give information necessary to the installation of the BTSE for the SBS Base Station System (BSS).

It contains the description of all steps to install the BTSE on site and the integration into the required infrastructure:

- Power supply.
- PCM30 - Network.
- Grounding.
- Receive / transmit antenna system.
- Alarm connections.

1.2. Overview Base Transceiver Station

1.2.1. Main Tasks

The BTSE performs the following main tasks in accordance with the GSM-requirement (D900):

- Provides the RF-link connection to the mobile stations (MS).
- Supports various cell types (omni cells).
- Provides the 2Mbit PCM30 link connection to the Base Station Controller (BSC) via a terrestrial line (in this case symmetric pair or coax cable is used).
- Submultiplexing on the Abis-interface.
- Multidrop loop and star PCM 30 link connection.

The BTSE is preset to send the four alarm signals detected by it according to the closed contact logic: alarm transmission, open contact: no alarm.

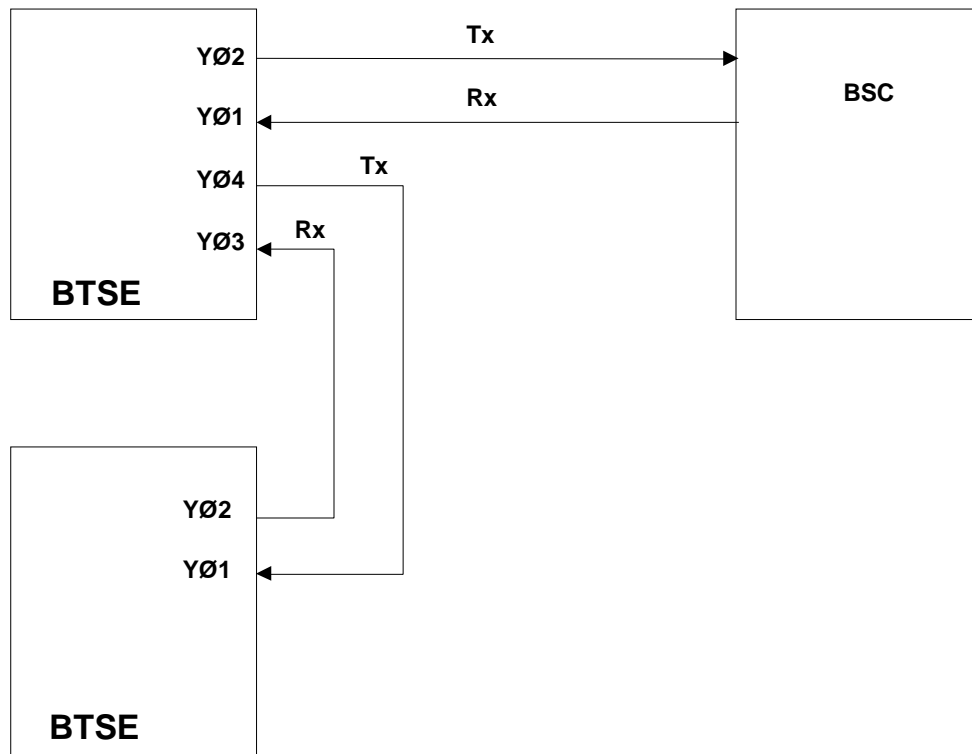

Fig. 1.1. BTSE in the SBS architecture

The Micro-Base Transceiver Stations are a modular family of BTS-products:

with internal antenna and 1 TRX:	BS-11i/900.1	BS-11i/1800.1
with external antenna and 1 TRX:	BS-11e/900.1	BS-11e/1800.1
with internal antenna and 2 TRX:	BS-11i/900.2	BS-11i/1800.2
with external antenna and 2 TRX:	BS-11e/900.2	BS-11e/1800.2

1.2.2. Standard Technical Features

- BS11/900 GSM 900 including Extended GSM Frequency Band (880-915 Mhz, 925-960 MHz).
- BS11/1800 DCS 1800, Frequency Band: 1710-1785 MHz, 1805-1880 MHz.
- Hardware for 8/16 Kb/s sub-multiplexing on Abis interface.
- BS11/900 M1, M2, M3 and 2 Watt GSM Power Classes.
- BS11/1800 M1, M2, M3 and 3 Watt DCS Power Classes.
- Two receiving chains for diversity.
- Hardware for realization of star and multidrop connection.
- Wall and pole mount kit.

2. BS-11i Installation (Internal antenna)

2.1. Site Requirements

The BS-11i (i is intended for internal antenna), called BTSE, is suitable for indoor- and outdoor operation.

The BTSE is protected from dust, rain and other external factors. The protection facilities are the following:

- IP 54.
- Burglar proof cabinet.
- Lightning arrestors on power supply and PCM 30 input.
- Connector protection cover supplied with wrenches and anti-intrusion microswitch.

Prior to the commencement of the installation, the site must have been prepared as follows:

- A wall of min. 1,50 kN/m² load-carrying capacity is required for wall mounting or, for pole mounting the pole dimensions must be sufficient to support the weight of the BTSE. For a maximum wind speed of 160 km/h, the BTSE produces a 400 kg load.
- The installation area should be clear of standing water, fallen leaves, mud and building debris.
- Necessary precautions should be taken against unauthorized access during the installation works.
- The lightning and grounding systems must be completed and tested.
- All installation works of 230 V AC or 110 V AC power supply must be finished.
- The PCM30 cables must have been installed.
- The cables of the alarm signals must have been preset to be – if necessary – connected to the BTSE later on.
- All the cables must be brought into the immediate vicinity of the BTSE, leaving 30 cm for the following operation of abutment of the cables to the BTSE connectors.

Whenever the Client considers it necessary, for the purpose of protecting the cables from attacks of vandalism, it is advisable to pass the cables through steel or galvanized iron tubes raceways.

It is advisable to make the 220 Vac power supply cables pass through a tube or raceway different from those used for the signal cables. Alternatively, it is possible to make all the cables pass through the same raceway, separating, however, the signal cables from the power supply cables by means of an insulating partition placed inside the raceway.

As detailed in para. 2.7.1., the BTSE can accept power supply voltage from 88 V AC to 265 V AC with frequency from 45 Hz to 65 Hz.

Power consumption:

Mono TRX = 100 W + 120 W with heater system inserted from -45 to -20 degrees external temperature.

Bi TRX = 200 W + 120 W with heater system inserted from -45 to -20 degrees external temperature.

2.2. Site Configuration

The installation site configuration is shown in Fig. 2.1. With regard to the alarm signal cables laid inside the buildings, it is necessary to insert some optoisolator devices on their line.

It is necessary to insert overvoltage protections on the alarm signal cables line laid outside buildings. With regard to the PCM30 cables, if considered necessary, a sectioning block can be inserted with the terminations.

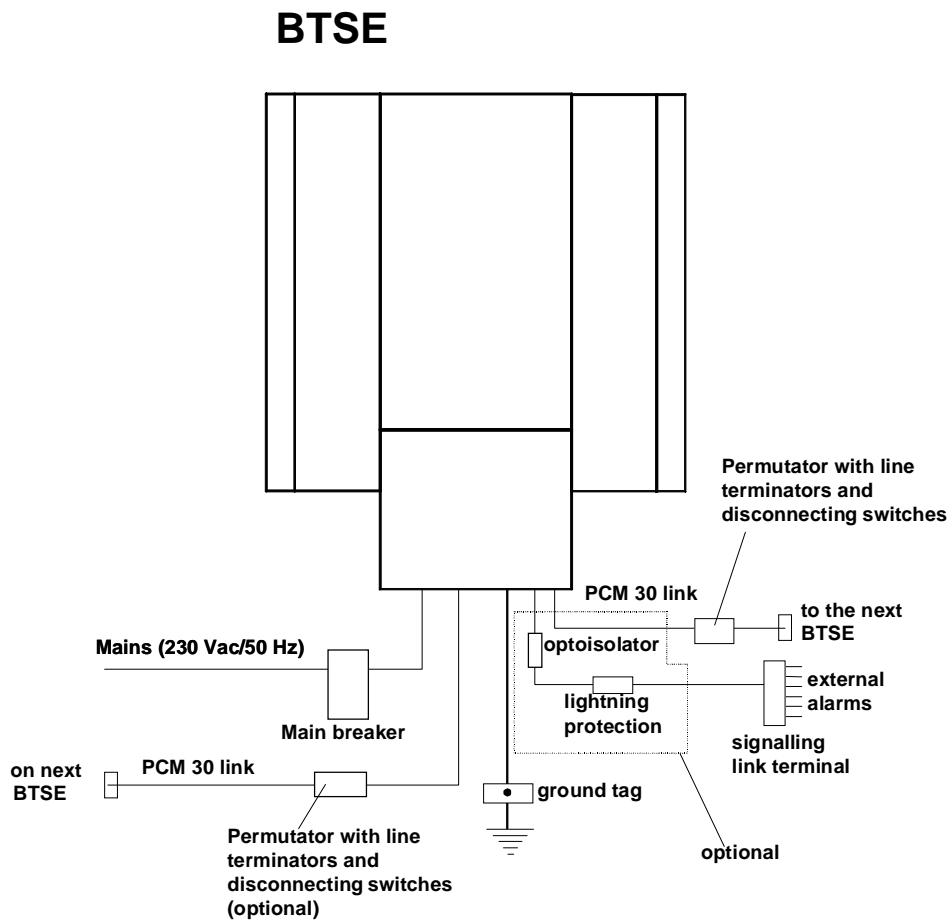

Fig. 2.1. Site Configuration

2.3. Construction View of the BTSE

The BTSE is housed in the shelter with dimensions 541 mm x 460 mm x 163 mm (HxWxD). The integrated climate control system guarantees proper outdoor operation (temp. range: -45° C ÷ +45° C).

The plug-in unit ACMDC (AC multiple DC converter) converts the primary input voltage into all needed DC voltages.

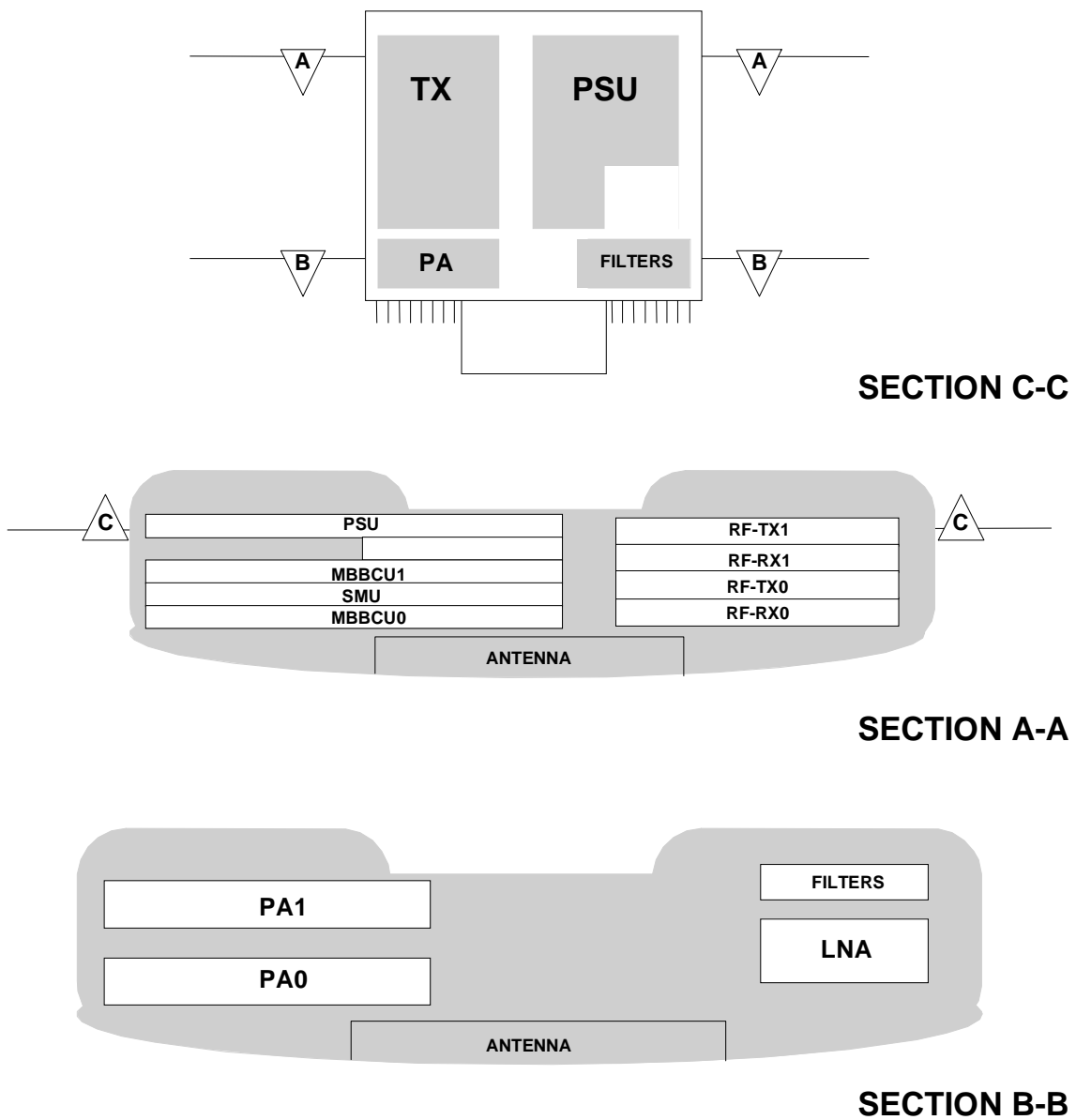

Fig. 2.2. BTSE: Location of boards and modules (BiTRX)

2.4. Equipment Delivery

The rack is shipped in a carton with the dimensions 60 x 50 x 20 cm (HxWxD). The crate can weight up to approx. 27 kg.

The packing consists of two cartons having identical dimensions (600x750x350 mm) containing, respectively:

- BTSE with support for fastening and antenna (weight 35 kg BiTRX; 31 Kg MonoTRX);
- Movable parts for fastening to pole/wall and solar shield (weight 12 kg).

Handle each carton containing installation material with extreme caution to avoid tipping.

The crate has the following information printed on them for identification of delivery:

- Trade mark.
- Customer order number.
- Serial number of rack or other supplied equipment.
- Destination.
- Gross and net weight.
- Overall dimensions (cm).
- Symbol or inprint to identify the "Top" and the "Bottom".

2.4.1. Preliminary Checks

Check that the cartons are not damaged. In case of evident damage due to transport, unpack the equipment in presence of an insurance company representative and promptly claim any damage and inform the shipper for specifying the damage.

Check whether the package is actually addressed to the site and complete.

Open it and take the contents out carefully.

After having removed all contents from the packing material, check for deformation to the devices, of torn or unwelded wiring, of oxidized connectors, as well as deformed front sides of the units, loose screws, damage to paint work etc.

2.4.2. BTSE Unpacking

During the unpacking steps great care must be taken to ensure that the BTSE is not scratched or damaged in any way. Proceed as follows:

- Cut the straps and remove the container cover.
- Take out the BTSE from the cardboard box.
- Open the tubular PE shrink-wrap protecting the BTSE and take it out.
- Remove the dehydrating material bags fixed with the adhesive tape.
- Remove the protection to the head and to the base of the BTSE.

- Lift the BTSE in vertical position.
- Remove the profiles protecting the BTSE edges.

2.4.3. Installation Kit Unpacking

Proceed as follows:

- Open the PVC wrap protecting the carton and withdraw it.
- Remove the dehydrating material bag from the box.
- Cut with a suitable knife the adhesive tape sealing the box.
- Take the installation kit.
- Open the PVC wrap protecting the device/board and withdraw it.

The packing material should be preserved for possible future re-packing. For this purpose, reverse the procedure described above, taking into account the warnings specified for the packing.

Installation is facilitated by the use of the handle with which the BTSE is equipped.

2.4.4. Spare parts for field maintenance

Suggested spare parts for field maintenance are:

Description	Part Number
Sun Shield Reddish color	332-0443/02
Green solar shields	332-0443/03
Beige solar shields	332-0443/04
Neutral solar shields	332-0443/01
Internal Antenna system	131-9222/01
Wall/Pole mechanical fitting	131-9221/01
Line protection module	130-3679/01
Power supply protection module	130-3680/01
Bottom covers for connectors	350-1339/01
Fuses	2622210252
Socket head Screw	15059000039
Look Key	10350000063

As facilities for field maintenance can be used

BS 11 local maintenance terminal interface kit	131-9441/01
--	-------------

2.5. Wall Mounting of the BTSE

2.5.1. Installation Tools

The correct rack installation is carried out with the aid of the following tools:

- Standard toolkit for BTSE installation.
- Spirit level.
- Plumb bob.
- Saw with shavings exhauster filter (for elevated floor only).
- Hammer drill.
- Drill widia
- Hammer.
- Screw driver for cross-slotted screw.

For installation of power distribution panels, cable ducts, antenna, cableways and other infrastructure equipment, additional tools could be necessary.

2.5.2. Ancillary Material

The following ancilliary materials are needed:

- Plumb line.
- Colophony.
- Adhesive tape (yellow/green) for labelling.
- Cable fasteners.

2.5.3. BTSE Installation Procedure

Prior to the commencement of BTSE installation, consult the site documentation to locate the installation point of the BTSE, the PCM 30 network termination, the connection point for AC mains and the nearest ground tag.

Necessary installation material (for fixing the wall mounting frame to the wall and for fixing the base plate to the wall) and washers for correct adjustment come with the delivery.

Proceed in steps as follows:

- Make six holes in the wall corresponding to the holes located on bracket (Fig. 2.3.).
- Insert in the wall six wallplugs (The wallplugs are not included in the installation kit because these wallplugs must be chosen in relation to the wall. The wallplug must receive at least a diameter 8 mm screw.

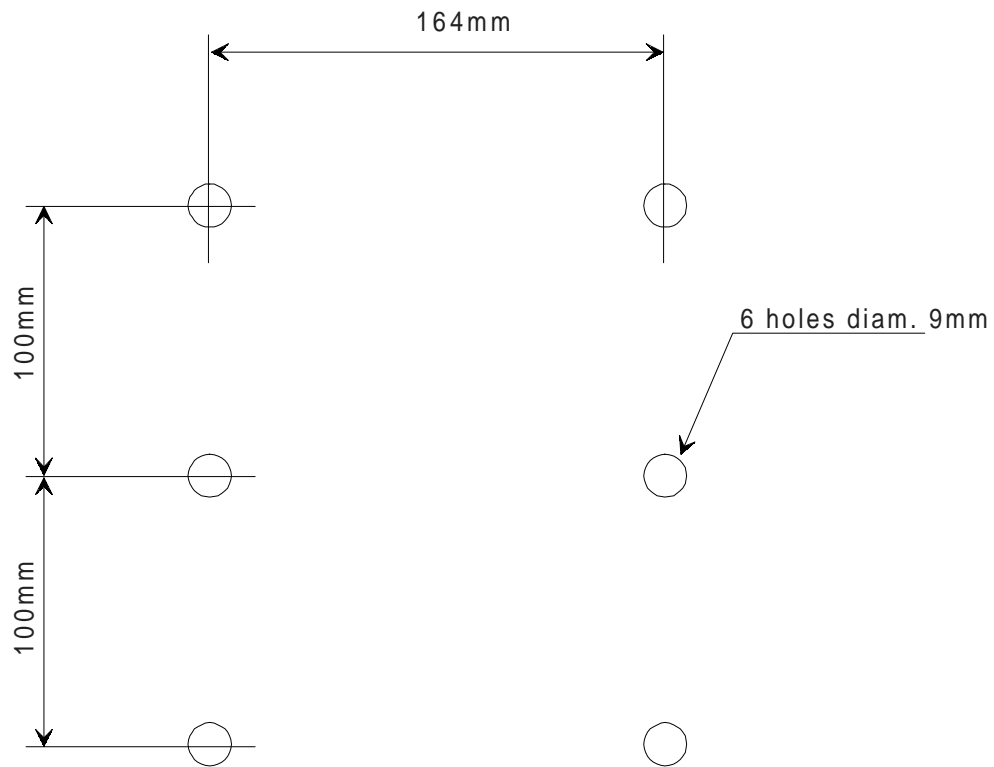

Fig. 2.3. Holes for wall mounting

- With reference to Fig. 2.4. fasten bracket (1) to the wall using six diameter 8 (2) screws and relative washers (3).
- Connect the BTSE (furnished joined with bracket (4)) to bracket (1).
- Tighten the M5 hexagonal head cap screw (5) using the proper wrench supplied.

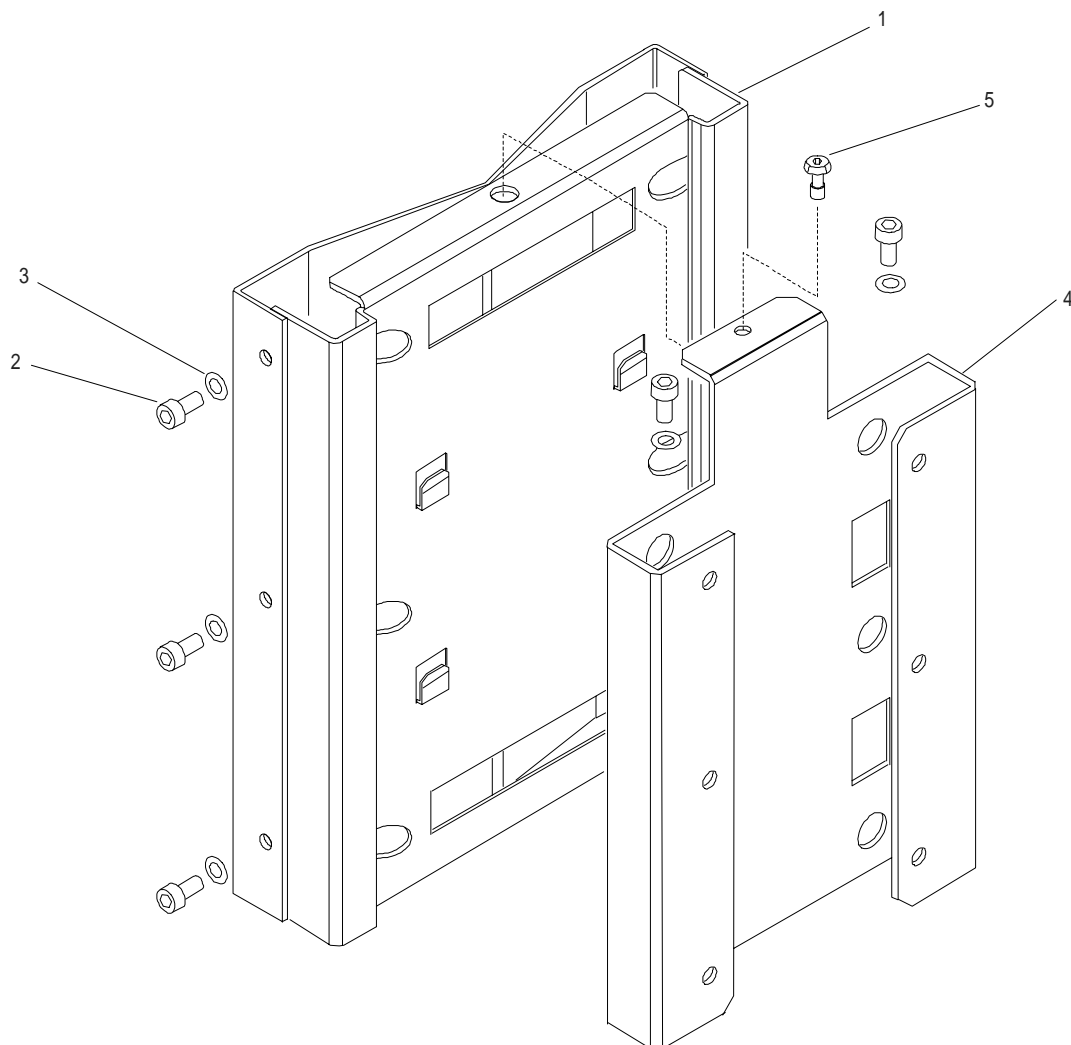

Fig. 2.4. BTSE: Wall mounting frame

2.5.4. Antenna mounting

After removing the antenna from the box, proceed as follows to install it (Fig. 2.5.):

- Position the Antenna (1) panel on the front of the BTSE.
- Tighten the four screws (2).
- Open the lower cover (1, Fig. 2.6.) of the BTSE to gain access to the connector panel using the appropriate wrench supplied.
- Tighten the four male type N connectors (which are connected to the antenna) to the RF connectors placed in the BTSE as shown in Fig. 2.7.
- Make sure that the BTSE is self-protected from adjacent structures with regard to the atmospheric discharges in accordance with the standards in force in the Country where it is installed. If the BTSE is not self-protected, a lightning rod must be installed.

2.5.5. Solar shield mounting

After removing the three elements that make up the solar shield from the box, proceed as follows (Fig. 2.5.):

- Position the upper panel (3) on the top of BTSE and fasten it with the four M4 Phillips head screws (4) tightening them with the appropriate wrench.
- Position panels (5) and (6) correctly on the BTSE and fasten them with the relative fastening screws (7) using the appropriate wrench supplied.

NOTE: *An extra screw is provided.*

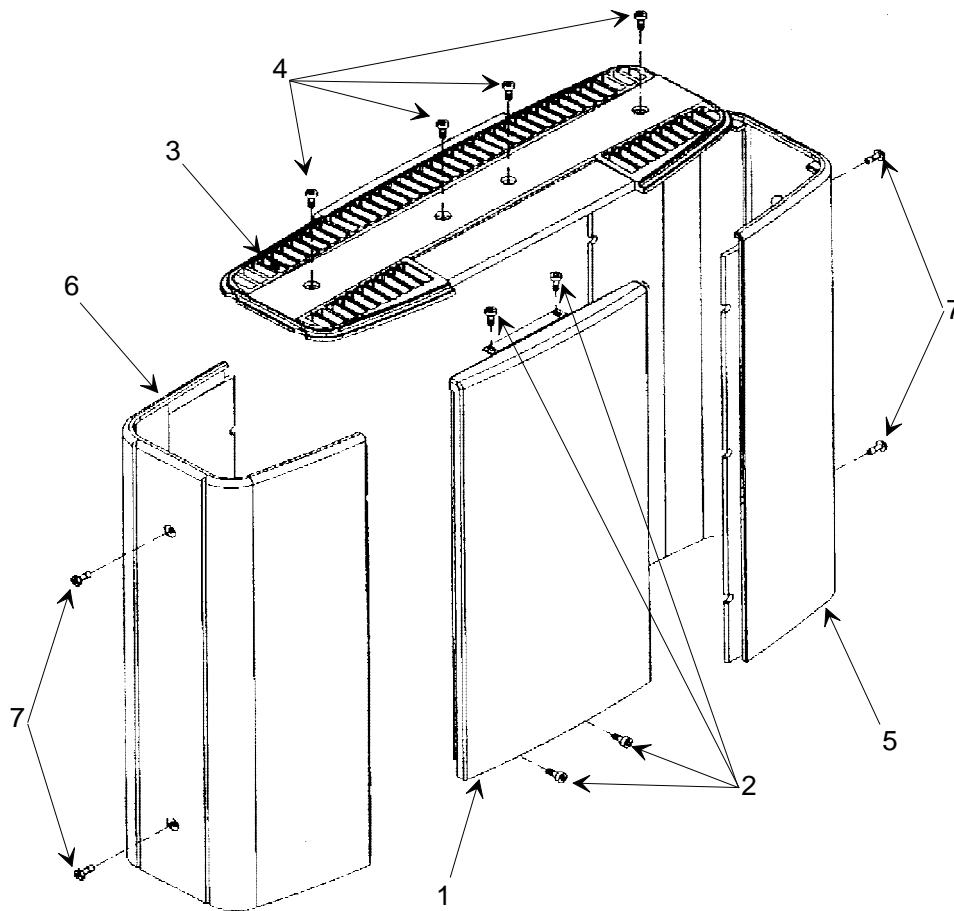

Fig. 2.5. Solar shield mounting

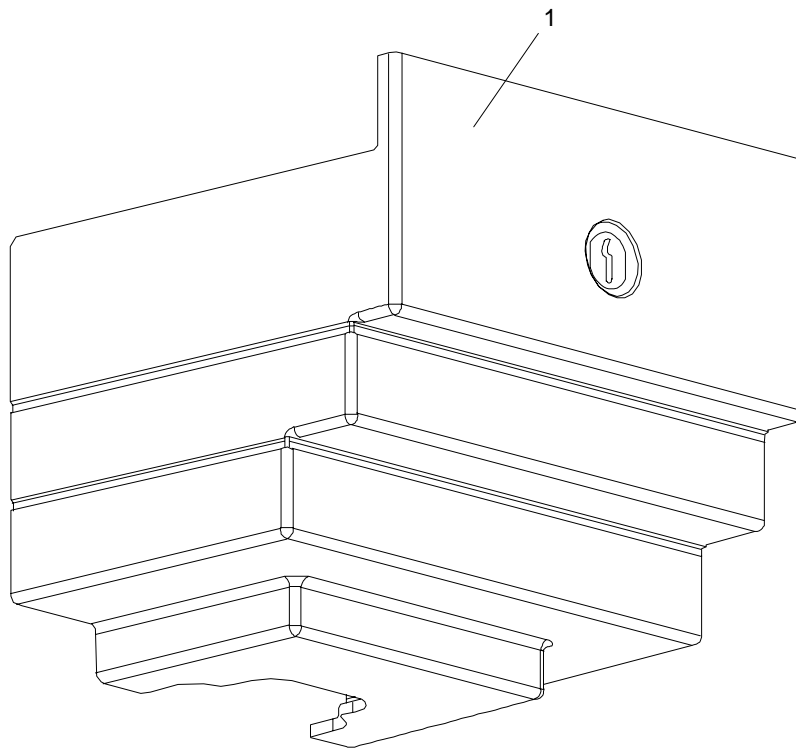

Fig. 2.6. Connector panel cover

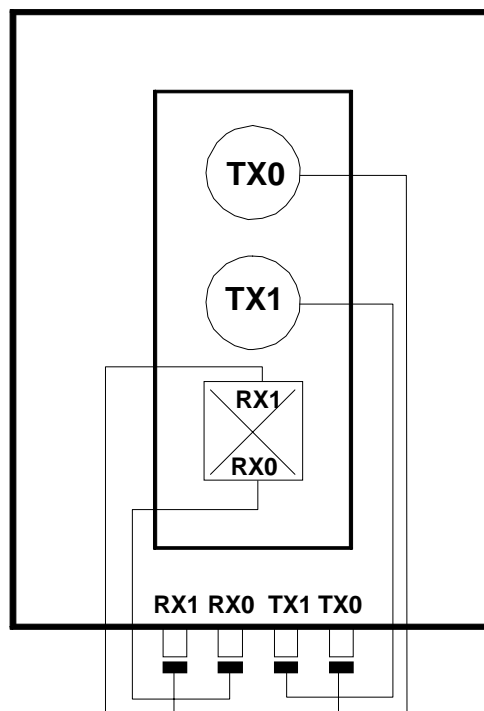

Fig. 2.7. Antenna connections (BiTRX internal antenna)

2.6. Pole Mounting of the BTSE

2.6.1. Installation Tools

The correct rack installation is carried out with the aid of the following tools:

- Standard toolkit for BTSE installation.
- Spirit level.
- Plumb bob.
- Saw with shavings exhauster filter (for elevated floor only).
- Hammer drill.
- Hammer.
- Screw driver for cross-slotted screw.

For installation of power distribution panels, cable ducts, antenna, cableways and other infrastructure equipment, additional tools could be necessary.

2.6.2. Ancillary Material

The following ancillary materials are needed:

- Plumb line.
- Colophony.
- Adhesive tape (yellow/green) for labeling.
- Cable fasteners.

2.6.3. BTSE Installation Procedure

Prior to the commencement of BTSE installation, consult the site documentation to locate the installation point of the BTSE, the PCM 30 network termination, the connection point for AC mains and the nearest ground tag. Necessary installation material such as wall plugs and screws (both for fixing the wall mounting frame to the wall and for fixing the base plate to the wall mounting frame) and washers for correct adjustment come with the delivery.

The system selected for pole installation is the BAND IT System. Installation is possible on poles ranging from 50 mm to 300 mm.

The following Kits of BAND IT products are available:

- BAND 19 x 0.76 mm type B x 206 q.ty 30 meters
- BUCKLE 19 mm type B x 256 q.ty 100 units
- Special BAND IT type B x 201 q.ty 1

Use the number of tapes (2 or 3) indicated below in relation to the pole diameter.
Use the holes indicated for fastening.

Pole diameter	Tape passage hole	Number of tapes (N)
70 mm	n.1	3
100 mm	n. 1	3
130 mm	n. 2	3
160 mm	n. 2	2
200 mm	n. 2	2
300 mm	n. 2	2

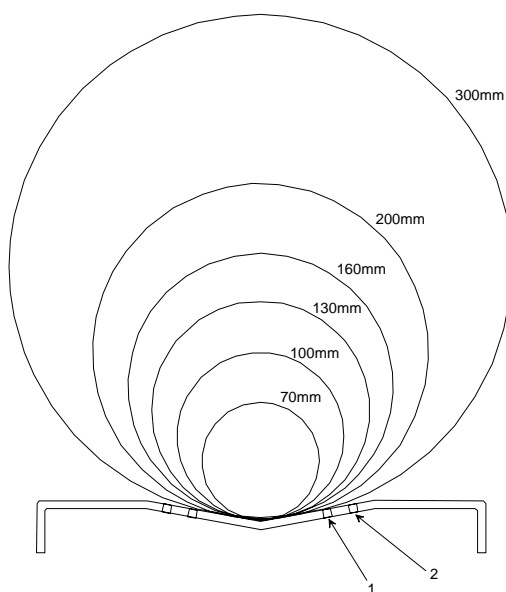

Proceed in steps as follows (Fig. 2.8.):

- Position bracket (1) on the pole (2). For this purpose:

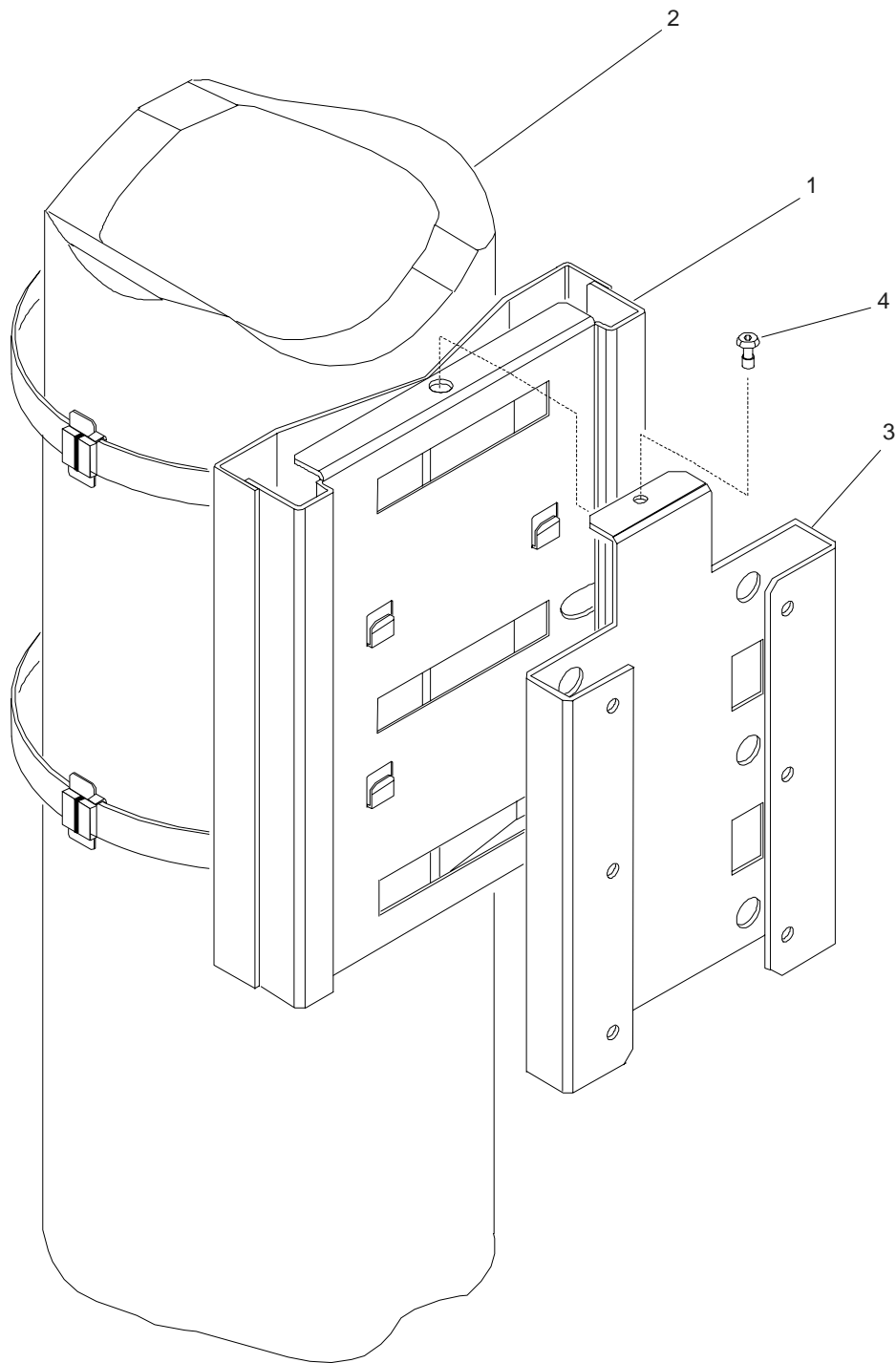

Fig. 2.8. BTSE: Pole mounting frame without tilting mechanism

- Band may be used from bulk roll as this completely eliminates waste of band. Slide buckle on band as shown in Fig. 2.9. bringing end of band around object to be clamped and again through buckle.



Fig. 2.9. Buckle slided on band

- Continue band around object once more and again through buckle (Fig. 2.10.) Double banding develops a great deal more radial compression than single banding. Bend end of band under buckle.



Fig. 2.10. Band around pole

- Place band in open slot of tool nose and in slide (Fig. 2.11.). With thumb on band gripper lever, apply tension by turning handle of tool. After tension is created, it is no longer necessary to hold band gripper lever as it locks itself under tension.

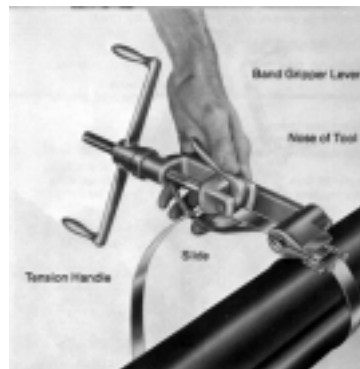

Fig. 2.11. Apply tension

- Place finger on Band-It Band at buckle bridge while tensioning with tool handle, maximum pressure is being exerted by the Band-It Band around object being clamped. Stop turning handle (Fig. 2.12.).



Fig. 2.12. Tightening

- Roll tool over buckle, backing off with tension handle throughout entire rolling operation (Fig. 2.13.). Failure to back off with tension handle throughout entire course of roll may result in breaking of band. There is no loss of tension as band released is used up in the bend.

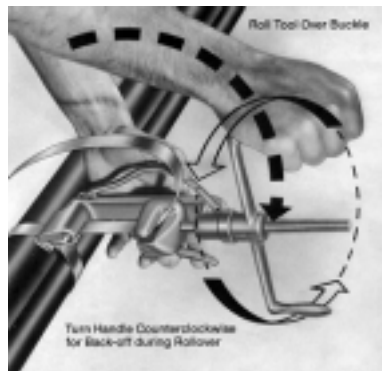

Fig. 2.13. Rolling tool

- Pull cutting handle to cut the band (Fig. 2.14.).



Fig. 2.14. Cutting the band

- Remove tool, holding stub of band down with thumb (Fig. 2.15.).

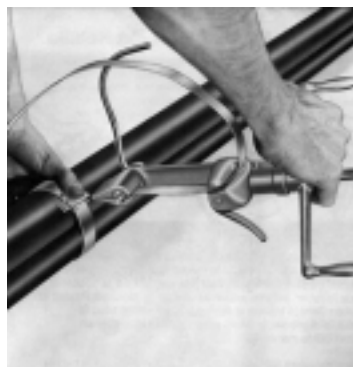

Fig. 2.15. Removing tool

- Clink stub by hammering down buckle ears, completing Band-It clamp (Fig. 2.16.).



Fig. 2.16. Hammering buckle ears

- Connect the BTSE (furnished joined to bracket (3)) to bracket (1).
- Tighten the M5 hexagonal head cap screw (4) using the proper wrench supplied.

2.6.4. Antenna mounting

Refer to section 2.5.4, where the procedure has already been described.

2.6.5. Solar shield mounting

Refer to section 2.5.5, where the procedure has already been described.

2.7. External Cabling Activities

This chapter gives information required for installing the external cables between the BTSE and the infrastructure equipment.

The rack cannot function without the following cable connections:

- terminal block: connection point of 230 V AC or 110 V AC
- ground bolt: grounding system
- Abis interface: PCM30 links
- RX/TX antenna connectors: transmit/receive antennas (just connected)

Refer to Fig. 2.17. for the location of the connectors at the connection.

The functions of the commands, indicators, connectors and fuses of the connection panel are as follows:

- Y01: Reception of the first PCM flux from BSC or from preceding BTSE
- Y02: Transmission of the first PCM flux to BSC or from preceding BTSE
- Y03: Reception of the second PCM flux from BSC or from the following/preceding BTSE
- Y04: Transmission of the second PCM flux to BSC or to the following BTSE
- J01: Test and alarm connector
- P1: Power supply connector
- F1-F2-F3-F4: 10A delayed fuses (F2-F4 spare in MonoTRX)
- SL01: Led with green light (when turned on it signals the presence of the 230 V AC power supply voltage)
- ON/OFF: Power supply switch. It is provided with protection against accidental shutdown.
- RX0: First RF reception (diversity)
- RX1: Second RF reception (diversity)
- TX0: RF transmission TRX0
- TX1: RF transmission TRX1

Note that all the cables external to the BTSE (as well as the internal ones) must be at zero self-extinguishing halogens.

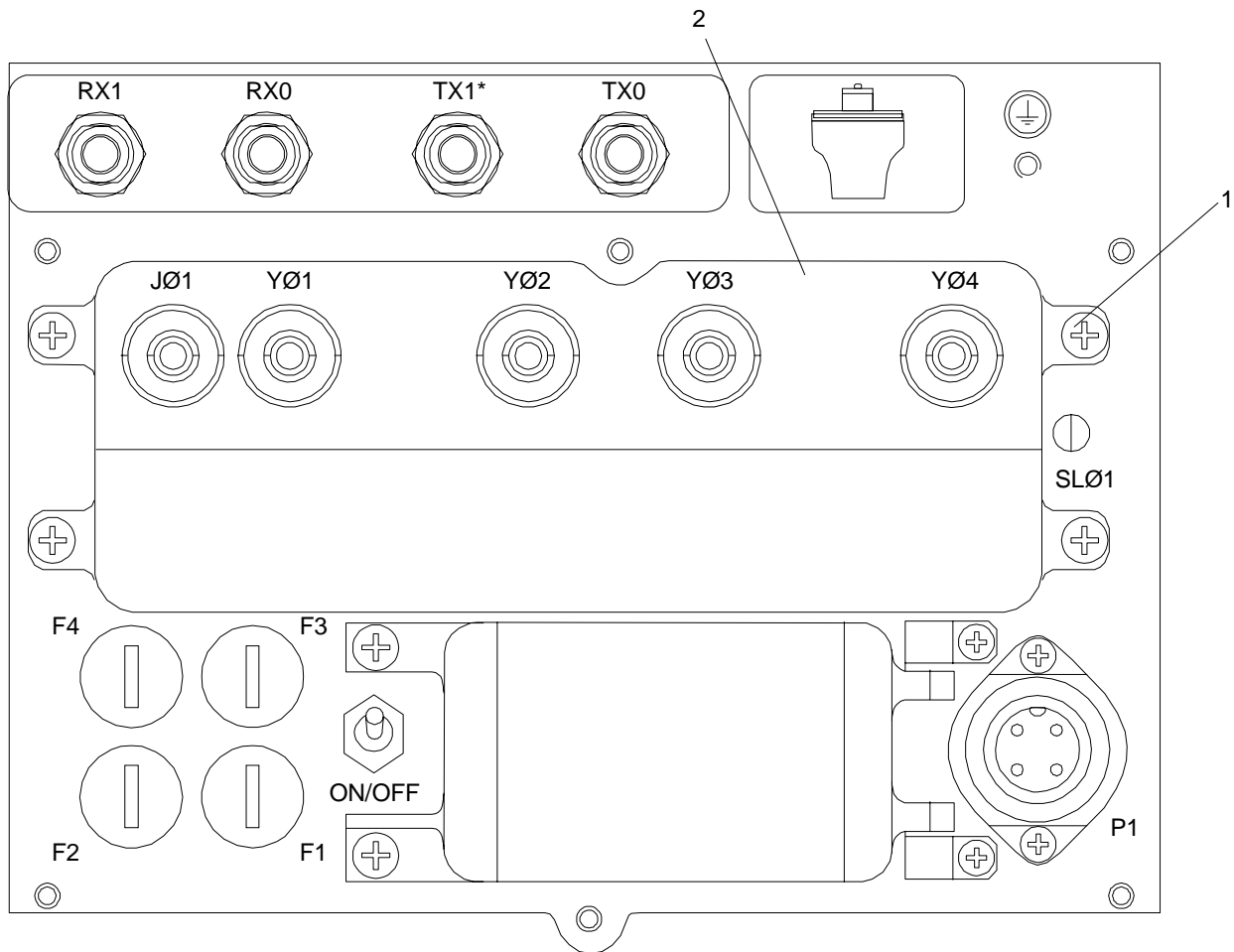

*only in BiTRX

Fig. 2.17. Connection panel

2.7.1. Ground and Power Supply Connections

The grounding and power supply connections must conform to the standards in force in the Country where the installation takes place.

A main cable in flexible raceway-plug is required for connecting the BTSE to the connection point of the 230 V AC power supply.

The terminal block for the 230V AC mains input is located below the BTSE (Fig. 2.18.).

The BTSE accepts either of the following nominal operating voltages indifferently:

- 110 V +15% -25% - 50 Hz \pm 10% - 60 Hz \pm 10% 220 W Max MonoTRX
- 230 V +15% -25% - 50 Hz \pm 10% - 60 Hz \pm 10%
320 W Max BiTRX

To connect the BTSE with the AC mains connection point proceed with the following steps:

- Using the appropriate wrench, remove the box covering the connectors, located on the lower side of the BTSE. The connector cover has already been opened to carry out the antenna installation (section 2.5.4).
- Refer to the site documentation for the required information about type and location of the 230 V AC connection point.
- The dimensioning of the power supply cable, of the grounding cable and of the magneto-thermal switch must be carried out according to the configuration of the BTSE installation site and with respect for the standards in force in the Country in which the installation takes place.
- Check the actual distance between the shelter and the connection point.
- Cut the cable for the required length.
- Fix wire end sleeves at the end that is to be connected to the connector.
- Lead the prepared cable through the cable access at the bottom of the shelter.
- Insert the prepared ends into the connector. With regard to the connector wiring, consult the instructions contained in the appendix.
- Fix the cable at the cable access by cable strap.
- Lead the main cable to the connection point for 230 V AC.

Note that the type and location of the mains connection point are subject to modification. They are dependent on site and customer requirements. A description of the connecting procedure does not form part of this manual. For further information refer to the site documentation and use the corresponding manufacturer documents.

The BTSE must be connected to the ground system.
For this purpose, there is a 6 mm diameter threaded hole underneath the BTSE.
Connect the BTSE and ground system as follows:

- Use the nearest connection point of the ground system.
- Ascertain the distances between the connection points of the ground system and the ground bolts of the shelter.
- Cut the cable (insulated, 6 mm²) to the required length.
- Remove the cable covering at the end to connect to the ground hole (length approx. 7 mm).
- Fasten a cable terminal to the ground cable and fasten it to the ground hole with a hexagonal head cap screw and 2 washers.
- Connect the prepared cable end to the ground bolt.
- Tighten the nut firmly.

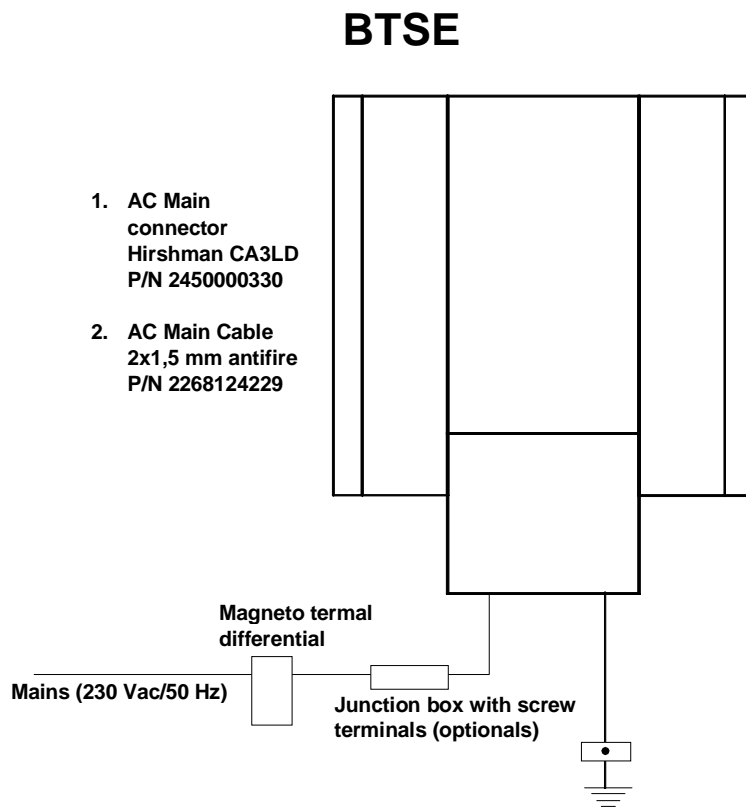

Fig. 2.18. Ground and power supply connections (example)

2.7.2. Abis Interface - PCM 30 Link Equipment

The PCM30 links access the BTSE via the Abis-interface, located at the connection panel (see Fig. 2.17.).

Fig. 2.19. shows two possible Abis configurations to connect the BTSE to the BSC. These configurations are called Star (single) and Multidrop (several).

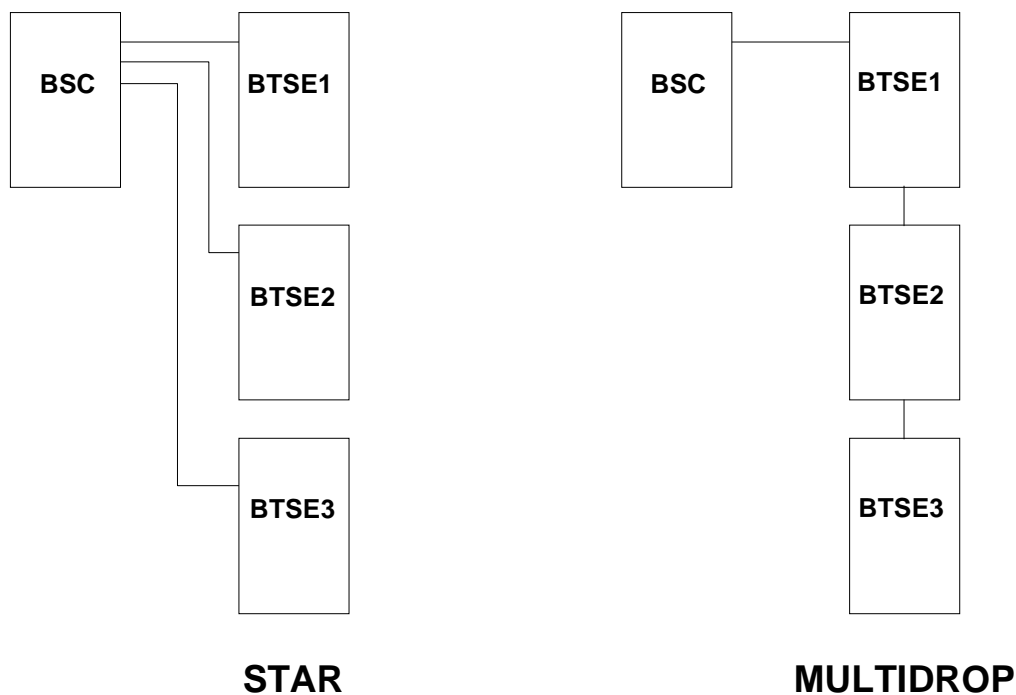

Fig. 2.19. STAR/MULTIDROP Configuration

The functions of the Y01 ÷ Y04 connectors (reception and transmission of the PCM fluxes) are illustrated in Fig. 2.20. ÷ Fig. 2.22.

Connection of the Abis-interface to the PCM 30 link terminal on site is as follows:

- Refer to the site documentation for the required information about the location of the PCM 30 link terminal, the type of shielded cable and of connector, which have to be used.
- Determine the real distance between rack and link terminal.
- Cut the PCM cables to the required length.

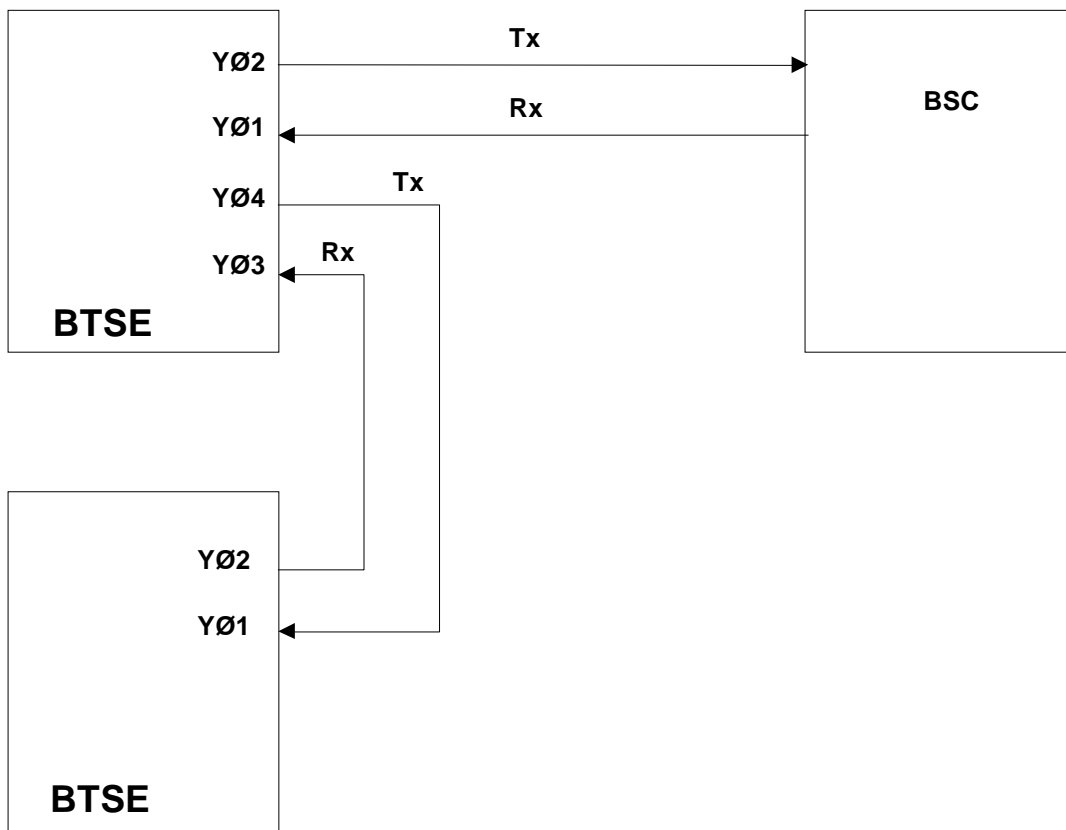

Fig. 2.20. Multidrop configuration Functions of Y01 ÷ Y04 connectors

- With reference to Fig. 2.23., remove the four screws (1) and remove the cover (2) to gain access to the Y01 ÷ Y04 connectors (Fig. 2.24.).
- Insert the four PCM cables in the four holes of the cover removed earlier.
- Abut the PCM cables to the relative connectors (the procedure is shown in the appendix).
- Remove the central plug of each core hitch.
- Pass each cable in the respective core hitch.
- Abut the movable connector to the cable.
- Insert the movable connectors in the respective fixed connectors.
- The BTSE is supplied with the output impedance preset to 75 Ω and with the PCM cable shield grounded. Whenever it is necessary to use the output impedance at 120 Ω or to disconnect the ground shield, consult the ITMN:BTSE BS11 manual.

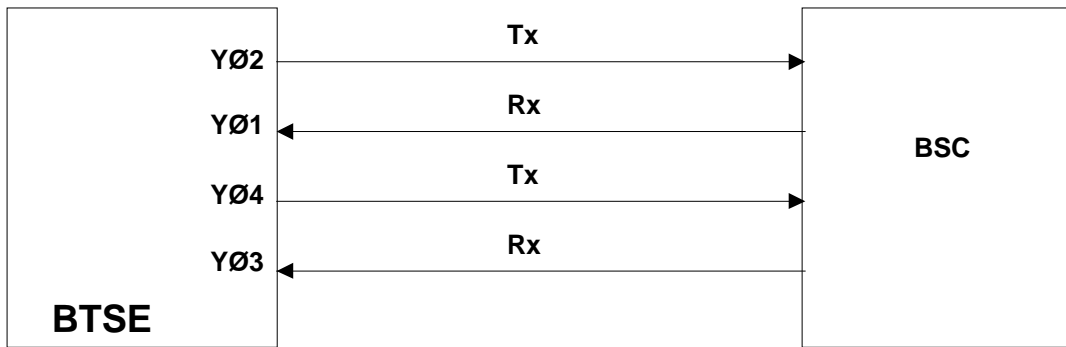
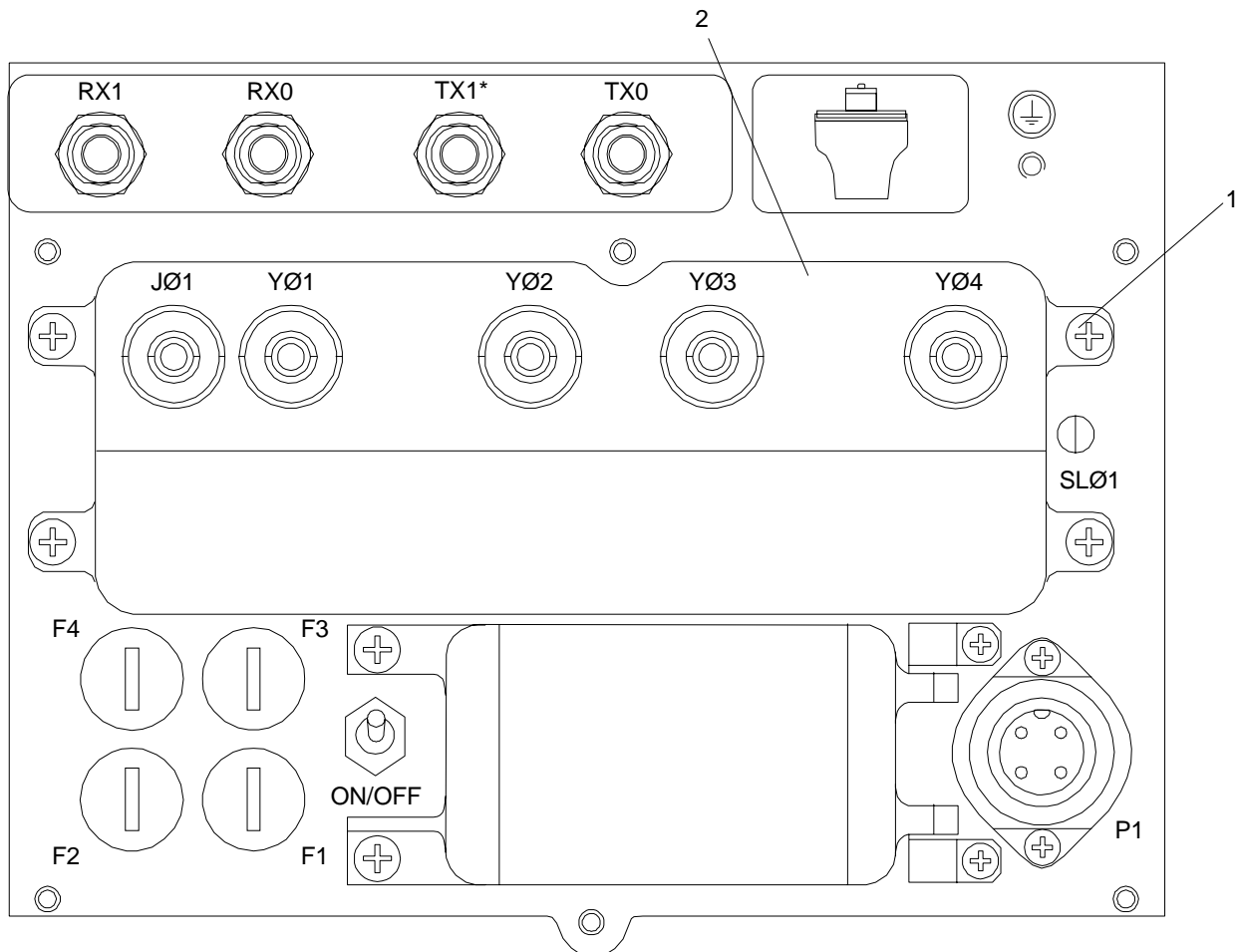

Fig. 2.21. Star configuration Functions of Y01 ÷ Y04 connectors



*only in BiTRX

Fig. 2.22. Connection Panel

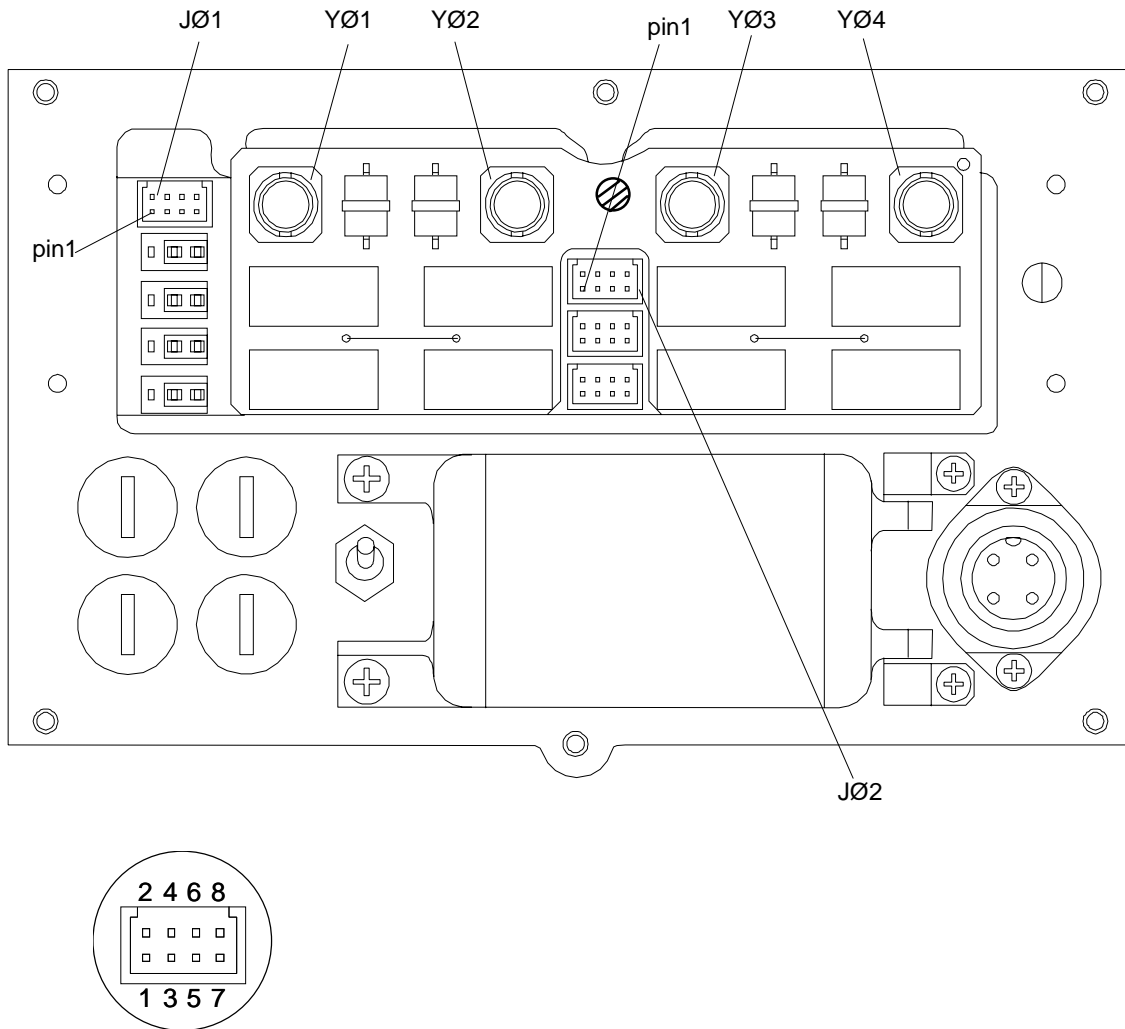

Fig. 2.23. Y01 ÷ Y04, J01 and J02 connectors

2.7.3. Connection to the J01 connector

After having connected the PCM30 cables, before closing the connector panel, connect the cable to the flying connector which will then be connected to J01.

The operations are described in the appendix.

NOTE: *The J02 connector serves for the connection with LMT.*

2.8. Post Installation Notes

After all installation works are finished and all cables clamped at the cable access, close the cable entry box (2, Fig. 2.23.).

Close the cover of the connector panel using the proper wrench.

Remove all packing material from site.

Call the commissioning staff for switch on, testing and network integration of the Base Station.

3. BS-11e Installation (External antenna)

3.1. Site Requirements

The BS-11e (e is intended for external), called BTSE, is suitable for indoor- and outdoor operation.

The BTSE is protected from dust, rain and other external factors. The protection facilities are the following:

- IP 54.
- Burglar proof cabinet.
- Lightning arrestors on power supply and PCM 30 input.
- Connector protection cover supplied with wrenches and anti-intrusion microswitch.

Prior to the commencement of the installation, the site must have been prepared as follows:

- The site specific-base construction must have been mounted.
- A wall of min. 1,50 kN/m² load-carrying capacity is required for wall mounting or, for pole mounting, the pole dimensions must be sufficient to support the weight of the BTSE. For a maximum wind speed of 160 km/h, the BTSE produces a 400 kg load.
- The installation area should be clear of standing water, fallen leaves, mud and building debris.
- Necessary precautions should be taken against unauthorized access during the installation works.
- The lightning and grounding systems must be completed and tested.
- The antenna lead-in must have been carried out and the antenna must have been protected from lightning.
- All installation works of 230 V AC or 110 V AC power supply must be finished.
- The PCM30 cables must have been installed.
- The cables of the alarm signals must have been preset to be – if necessary – connected to the BTSE later on.
- If the BTSE is pole mounted, install a switching box to the base of the pole and abut only the cable that goes to the J02 connector of the BTSE (connector for LMT) to the switching box.

As detailed in para. 3.7.1., the BTSE can accept power supply voltage from 83 V AC to 265 V AC with frequency from 45 Hz to 65 Hz.

Power consumption:

Mono TRX = 100 W + 120 W with heater system inserted from –45 to –20 degrees external temperature.

Bi TRX = 200 W + 120 W with heater system inserted from –45 to –20 degrees external temperature.

- All the cables must be brought into the immediate vicinity of the BTSE, leaving 30 cm for the following operation of abutment of the cables to the BTSE connectors.

Whenever the Client considers it necessary, for the purpose of protecting the cables from attacks of vandalism, it is advisable to pass the cables through steel or galvanized iron tubes raceways.

It is advisable to make the 220 Vac power supply cables pass through a tube or raceway different from those used for the signal cables. Alternatively, it is possible to make all the cables pass through the same raceway, separating, however, the signal cables from the power supply cables by means of an insulating partition placed inside the raceway.

3.2. Site Configuration

The installation site configuration is shown in Fig. 3.1. With regard to the alarm signal cables laid inside the buildings, it is necessary to insert some optoinsulator devices on their line.

It is necessary to insert overvoltage protections on the alarm signal cables line laid outside buildings. With regard to the PCM30 cables, if considered necessary, a sectioning block can be inserted with the terminations.

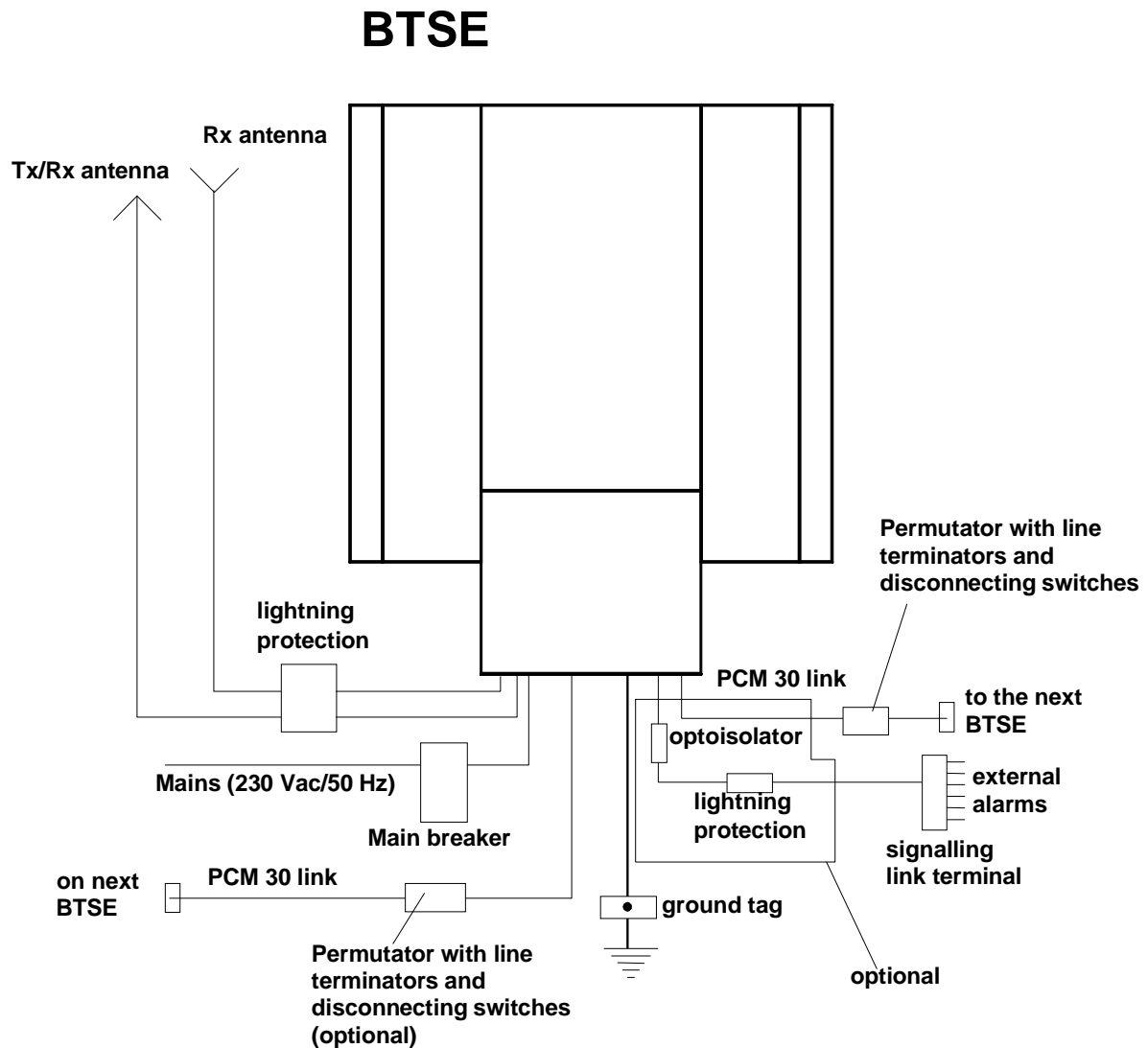

Fig. 3.1. Site Configuration

3.3. Construction View of the BTSE

The BTS equipment is housed in the shelter with dimensions 541 mm x 460 mm x 163 mm (HxWxD).

The integrated climate control system guarantees proper outdoor operation (temp. range: -45° C ÷ +45° C).

The plug-in unit ACMDC (AC multiple DC converter) converts the primary input voltage into all needed DC voltages.

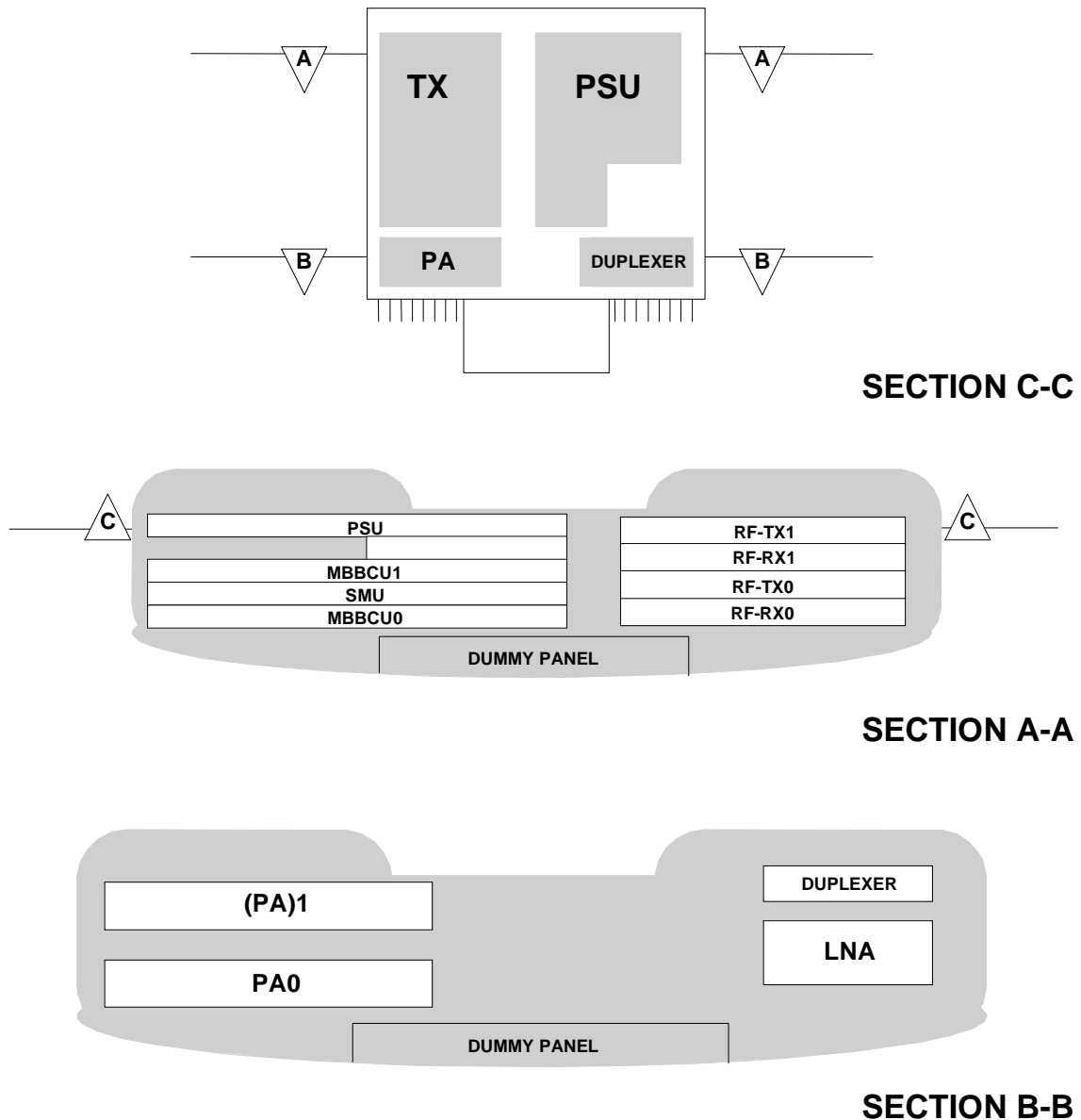

Fig. 3.2. BTSE: Location of boards and modules (BiTRX)

3.4. Equipment Delivery

The rack is shipped in a carton with the dimensions 60 x 50 x 20 cm (HxWxD). The crate can weight up to approx. 27 kg.

The packing consists of two cartons having identical dimensions (600x750x350 m) containing, respectively:

- BTSE with support for fastening and antenna (weight 35 kg BiTRX; 31 Kg. MonoTRX);
- Movable parts for fastening to pole/wall and solar shield (weight 12 kg).

Handle each carton containing installation material with extreme caution to avoid tipping.

The crate has the following information printed on them for identification of delivery:

- Trade mark.
- Customer order number.
- Serial number of rack or other supplied equipment.
- Destination.
- Gross and net weight.
- Overall dimensions (cm).
- Symbol or imprint to identify the "Top" and the "Bottom".

3.4.1. Preliminary Checks

Check that the cartons are not damaged. In case of evident damage due to transport, unpack the equipment in presence of an insurance company representative and promptly claim any damage and inform the shipper for specifying the damage.

Check whether the package is actually addressed to the site and complete.

Open it and take the contents out carefully.

After having removed all contents from the packing material, check for deformation to the devices, of torn or unwelded wiring, of oxidized connectors, as well as deformed front sides of the units, loose screws, damage to paint work etc.

3.4.2. BTSE Unpacking

During the unpacking steps great care must be taken to ensure that the BTSE is not scratched or damaged in any way. Proceed as follows:

- Cut the straps and remove the container cover.
- Take out the BTSE from the cardboard box.
- Open the tubular PE shrink-wrap protecting the BTSE and take it out.
- Remove the dehydrating material bags fixed with the adhesive tape.
- Remove the protection to the head and to the base of the BTSE.
- Lift the BTSE in vertical position.
- Remove the profiles protecting the BTSE edges.

3.4.3. Installation Kit Unpacking

Proceed as follows:

- Open the PVC wrap protecting the carton and withdraw it.
- Remove the dehydrating material bag from the box.
- Cut with a suitable knife the adhesive tape sealing the box.

- Take the installation kit out.
- Open the PVC wrap protecting the device/board and withdraw it.

The packing material should be preserved for possible future re-packing. For this purpose, reverse the procedure described above, taking into account the warnings specified for the packing.

Installation is facilitated by the use of the handle with which the BTSE is equipped.

3.4.4. Spare parts for field maintenance

Suggested spare parts for field maintenance are:

Description	Part Number
Sun Shield Reddish color	332-0443/02
Green solar shields	332-0443/03
Beige solar shields	332-0443/04
Neutral solar shields	332-0443/01
Dummy antenna	332-0450/01
Wall/Pole mechanical fitting	131-9221/01
Line protection module	130-3679/01
Power supply protection module	130-3680/01
Bottom covers for connectors	350-1339/01
Fuses	2622210252
Socket head Screw	15059000039
Look Key	10350000063

As facilities for field maintenance can be used

BS 11 local maintenance terminal interface kit	131-9441/01
--	-------------

3.5. Wall Mounting of the BTSE

3.5.1. Installation Tools

The correct rack installation is carried out with the aid of the following tools:

- Standard toolkit for BTSE installation.
- Spirit level.
- Plumb bob.
- Saw with shavings exhausted filter (for elevated floor only).
- Hammer drill.

- Drill widia
- Hammer.
- Screw driver for cross-slotted screw.

For installation of power distribution panels, cable ducts, antenna, cableways and other infrastructure equipment, additional tools could be necessary.

3.5.2. Ancillary Material

The following ancillary materials are needed:

- Plumb line.
- Colophony.
- Adhesive tape (yellow/green) for labelling.
- Cable fasteners.

3.5.3. BTSE Installation Procedure

Prior to the commencement of BTSE installation, consult the site documentation to locate the installation point of the BTSE, the PCM 30 network termination, the connection point for AC mains and the nearest ground tag.

Necessary installation material (for fixing the wall mounting frame to the wall and for fixing the base plate to the wall) come with the delivery.

Proceed in steps as follows:

- Make six holes in the wall corresponding to the holes located on bracket (Fig. 3.3.).
- Insert in the wall six wallplugs (The wallplugs are not included in the installation kit because these wallplugs must be chosen in relation to the wall. The wallplug must receive at least a diameter 8 mm screw.

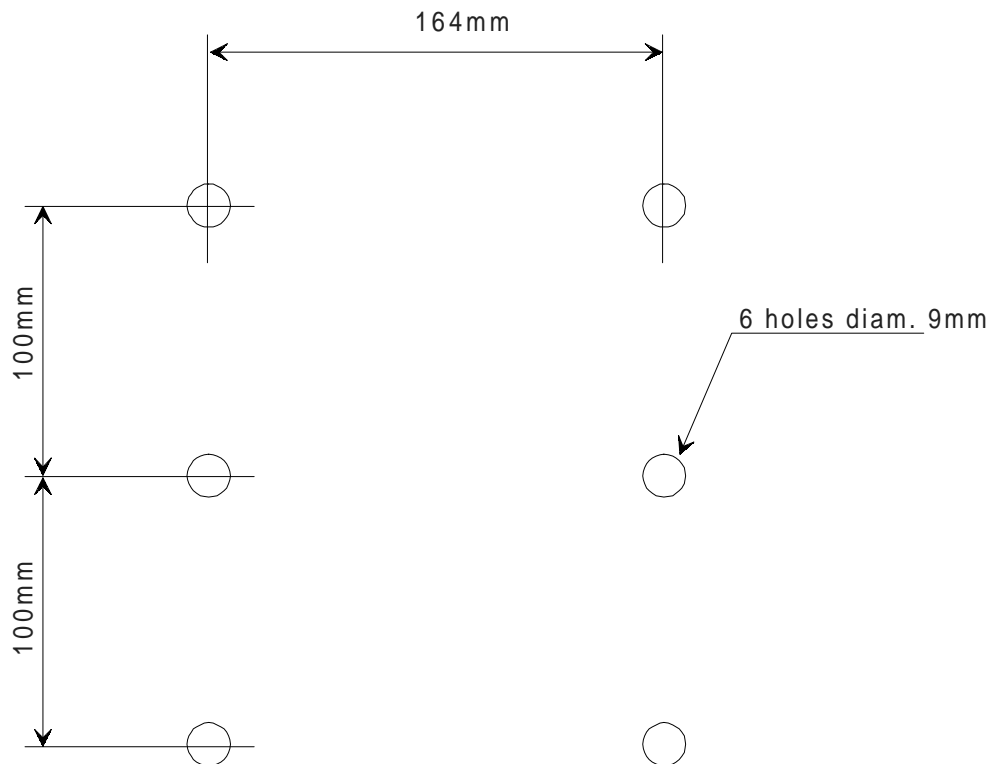

Fig. 3.3. Holes for wall mounting

- With reference to Fig. 3.4. fasten bracket (1) to the wall using six diameter 8 (2) screws and relative washers (3).
- Connect the BTSE joined with bracket (4) to bracket (1).
- Tighten the M5 hexagonal head cap screw (5) using the proper wrench supplied.

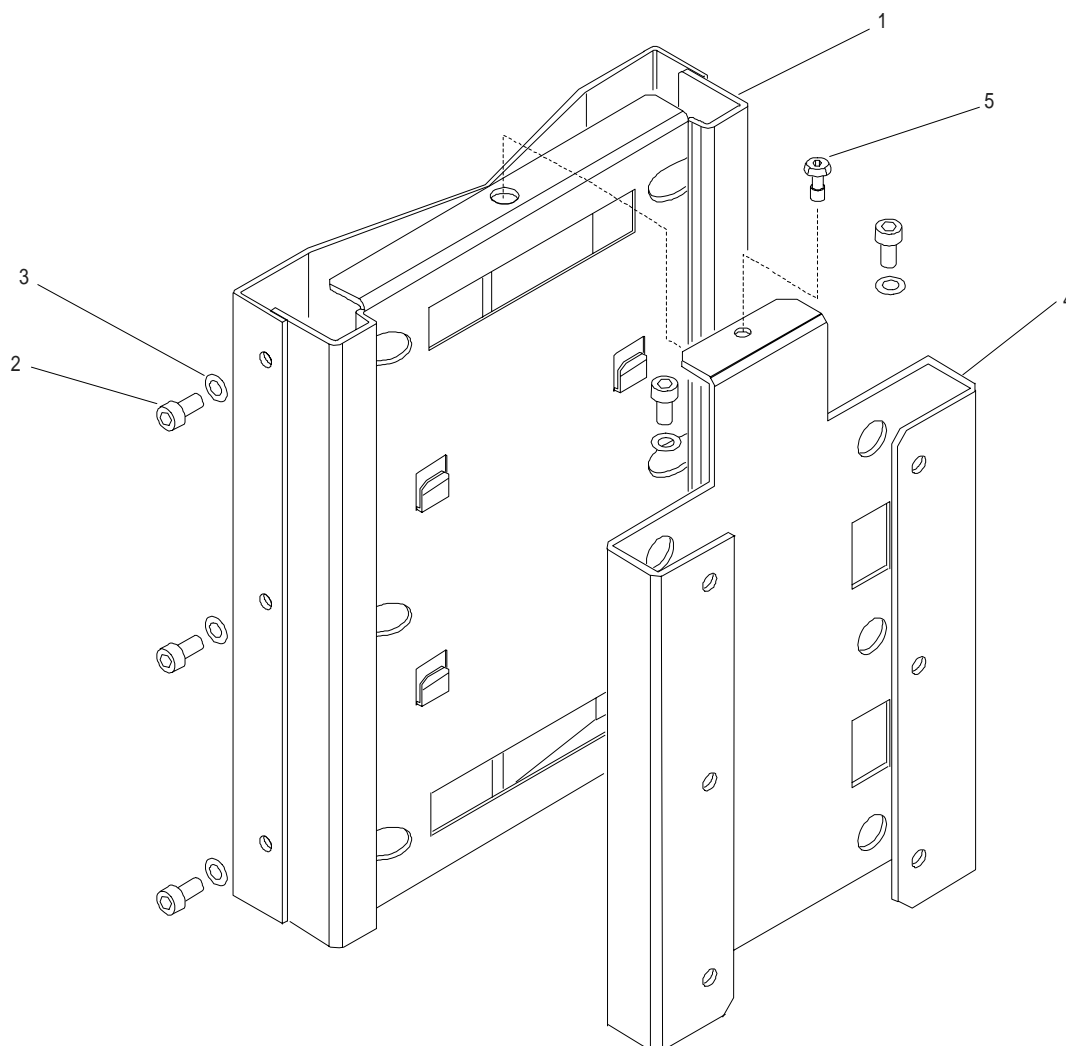

Fig. 3.4. BTSE: Wall mounting frame

3.5.4. Dummy panel mounting

After removing the antenna from the box, proceed as follows to install it (Fig. 3.5):

- Position the dummy panel (1) on the front of the BTSE.
- Tighten the four screws (2).

3.5.5. Solar shield mounting

After removing the three elements that make up the solar shield from the box, proceed as follows (Fig. 3.5.):

- Position the upper panel (3) on the top of BTSE and fasten it with the four M4 Phillips head screws (4) tightening them with the appropriate wrench.
- Position panels (5) and (6) correctly on the BTSE and fasten them with the relative fastening screws (7) using the appropriate wrench supplied.

NOTE: *An extra screw is provided.*

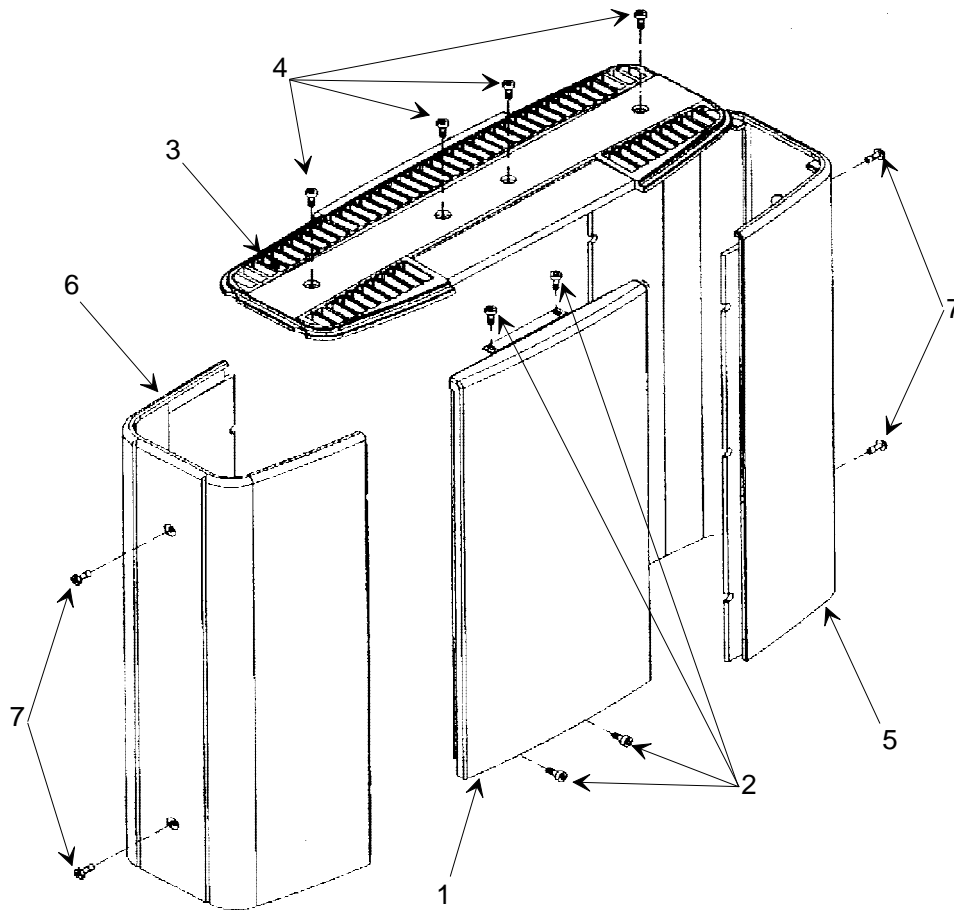

Fig. 3.5. Solar shield mounting

3.6. Pole Mounting of the BTSE

3.6.1. Installation Tools

The correct rack installation is carried out with the aid of the following tools:

- Standard toolkit for BTSE installation.
- Spirit level.
- Plumb bob.
- Saw with shavings exhauster filter (for elevated floor only).
- Hammer drill.
- Hammer.
- Screw driver for cross-slotted screw.

For installation of power distribution panels, cable ducts, antenna, cableways and other infrastructure equipment, additional tools could be necessary.

3.6.2. Ancillary Material

The following ancillary materials are needed:

- Plumb line.
- Colophony.
- Adhesive tape (yellow/green) for labelling.
- Cable fasteners.

3.6.3. BTSE Installation Procedure

Prior to the commencement of BTSE installation, consult the site documentation to locate the installation point of the BTSE, the PCM 30 network termination, the connection point for AC mains and the nearest ground tag. Necessary installation material such as wall plugs and screws (both for fixing the wall mounting frame to the wall and for fixing the base plate to the wall mounting frame) and washers for correct adjustment come with the delivery.

The system selected for pole installation is the BAND IT System. Installation is possible on poles ranging from 50 mm to 300 mm.

The following Kits of BAND IT products are available:

- BAND 19 x 0.76 mm type B x 206 q.ty 30 meters
- BUCKLE 19 mm type B x 256 q.ty 100 units
- Special BAND IT type B x 201 q.ty 1

Use the number of tapes (2 or 3) indicated below in relation to the pole diameter.
Use the holes indicated for fastening.

Pole diameter	Tape passage hole	Number of tapes (N)
70 mm	n.1	3
100 mm	n. 1	3
130 mm	n. 2	3
160 mm	n. 2	2
200 mm	n. 2	2
300 mm	n. 2	2

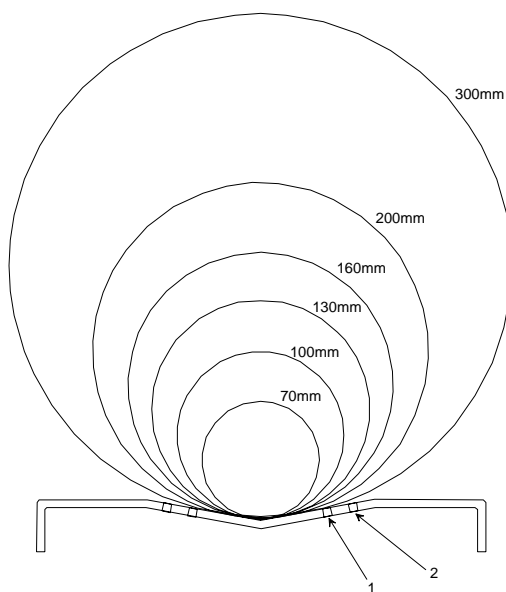

Proceed in steps as follows (Fig. 3.6.):

- Position bracket (1) on the pole (2). For this purpose:

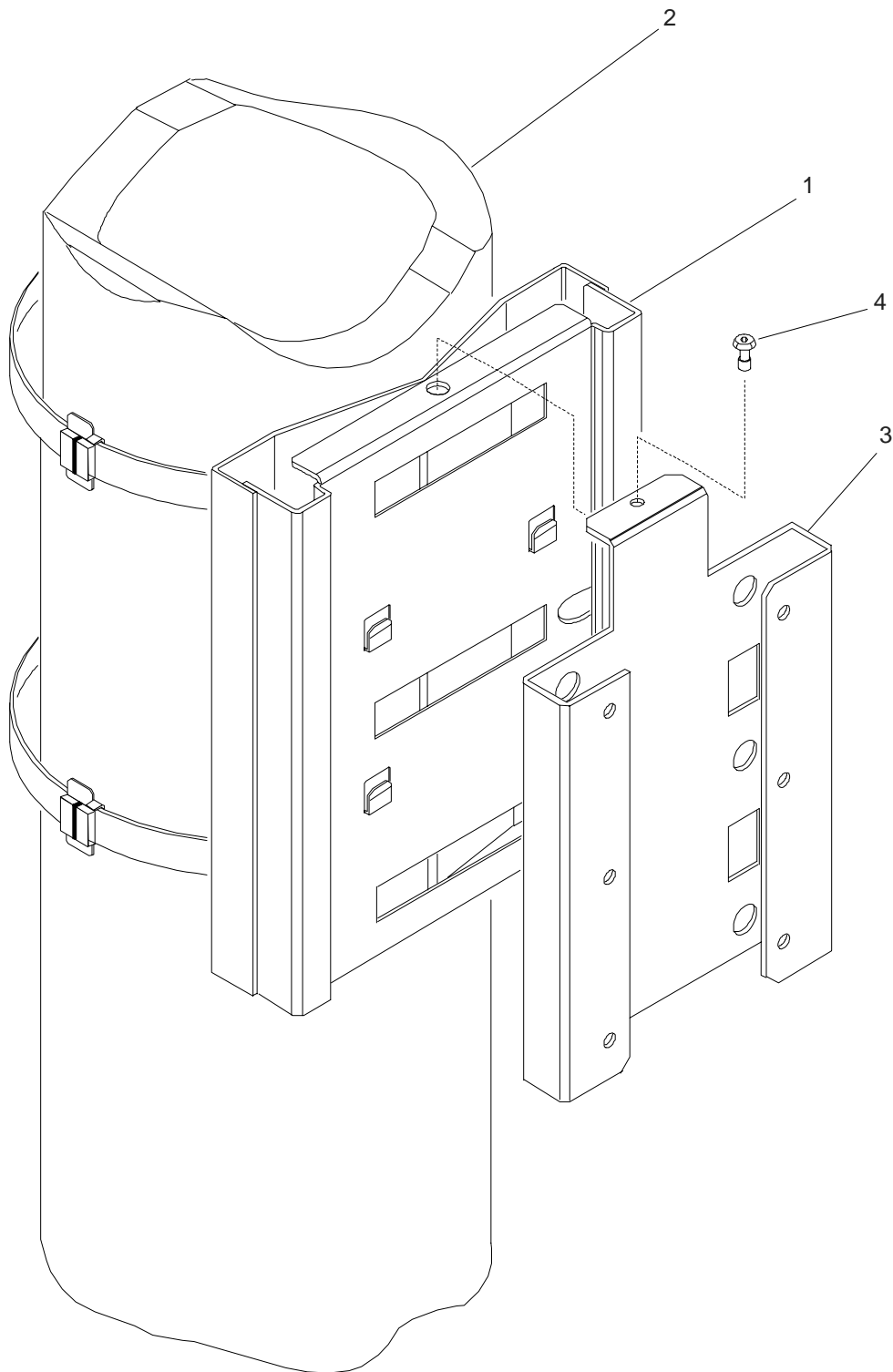

Fig. 3.6. BTSE: Pole mounting frame

- Band may be used from bulk roll as this completely eliminates waste of band. Slide buckle on band as shown in Fig. 3.7. bringing end of band around object to be clamped and again through buckle.



Fig. 3.7. Buckle slided on band

- Continue band around object once more and again through buckle (Fig. 3.8.) Double banding develops a great deal more radial compression than single banding. Bend end of band under buckle.

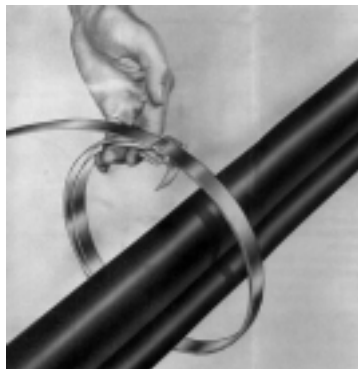

Fig. 3.8. Band around pole

- Place band in open slot of tool nose and in slide (Fig. 3.9.). With thumb on band gripper lever, apply tension by turning handle of tool. After tension is created, it is no longer necessary to hold band gripper lever as it locks itself under tension.

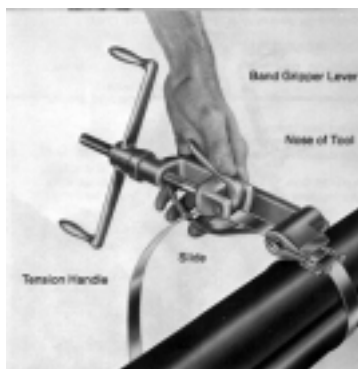

Fig. 3.9. Apply tension

- Place finger on Band-It Band at buckle bridge while tensioning with tool handle, maximum pressure is being exerted by the Band-It Band around object being clamped. Stop turning handle (Fig. 3.10.).



Fig. 3.10. Tightening

- Roll tool over buckle, backing off with tension handle throughout entire rolling operation (Fig. 3.11.). Failure to back off with tension handle throughout entire course of roll may result in breaking of band. There is no loss of tension as band released is used up in the bend.

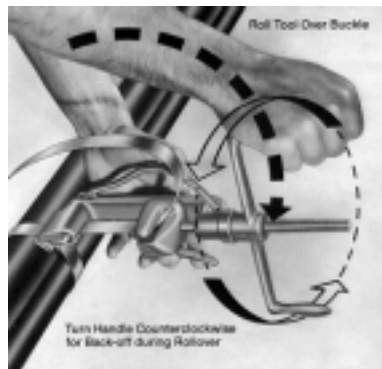

Fig. 3.11. Rolling tool

- Pull cutting handle to cut the band (Fig. 3.12.).



Fig. 3.12. Cutting the band

- Remove tool, holding stub of band down with thumb (Fig. 3.13.).

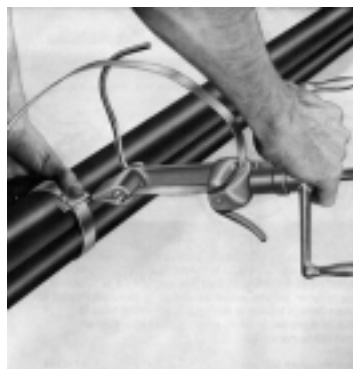

Fig. 3.13. Removing tool

- Clink stub by hammering down buckle ears, completing Band-It clamp (Fig. 3.14.).



Fig. 3.14. Hammering buckle ears

- Connect the BTSE joined to bracket (3) to bracket (1).
- Tighten the M5 hexagonal head cap screw (4) using the proper wrench supplied.

3.6.4. Solar shield mounting

Refer to section 3.5.5, where the procedure has already been described.

3.7. External Cabling Activities

This chapter gives information required for installing the external cables between the BTSE and the infrastructure equipment.

The rack cannot function without the following cable connections:

- terminal block: connection point of 230 V AC or 110 V AC
- ground bolt: grounding system
- Abis interface: PCM30 links
- RX/TX antenna connectors: transmit/receive antennas (just connected)

Refer to Fig. 3.15. for the location of the connectors at the connection panel and remember that TX2 is not used.

The functions of the commands, indicators, connectors and fuses of the connection panel are as follows:

- Y01: Reception of the first PCM flux from BSC or from preceding BTSE
- Y02: Transmission of the first PCM flux to BSC or from preceding BTSE

- Y03: Reception of the second PCM flux from BSC or from the following/preceding BTSE
- Y04: Transmission of the second PCM flux to BSC or to the following BTSE
- J01: Test and alarm connector
- P1: Power supply connector
- F1-F2-F3-F4: 10A delayed fuses (F2-F4 spare in MonoTRX)
- SL01: Led with green light (when turned on it signals the presence of the 230 V AC power supply voltage)
- ON/OFF: Power supply switch. It is provided with protection against accidental shutdown.
- RX0/TX0: First RF reception (diversity) and RF transmission
- RX1/TX1*: Second RF reception (diversity) and *RF transmission if BiTRX
- TX0: RF transmission

Note that all the cables external to the BTSE (as well as the internal ones) must be at zero self-extinguishing halogens.

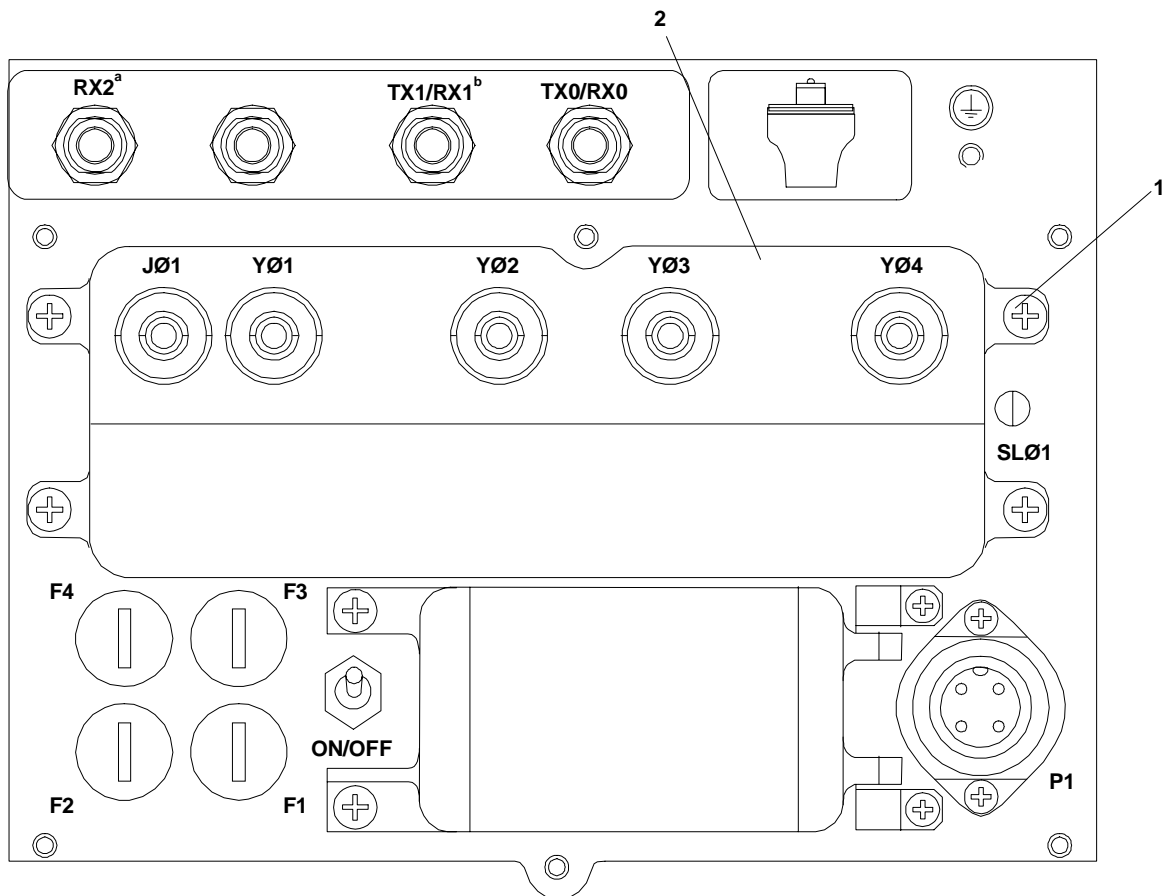

a = Diversity for MonoTRX
b = BiTRX

Fig. 3.15. Connection panel

3.7.1. Ground and Power Supply Connections

The grounding and power supply connections must conform to the standards in force in the Country where the installation takes place.

A main cable in flexible raceway-plug is required for connecting the BTSE to the connection point of the 230 V AC power supply.

The terminal block for the 230V AC mains input is located below the BTSE (Fig. 3.16.).

The BTSE accepts either of the following nominal operating voltages indifferently:

- 110 V +15% -25% - 50 Hz \pm 10% - 60 Hz \pm 10% 220 W Max MonoTRX
- 230 V +15% -25% - 50 Hz \pm 10% - 60 Hz \pm 10% 320 W Max BiTRX

To connect the BTSE with the AC mains connection point proceed with the following steps:

- Using the appropriate wrench, remove the box covering the connectors, located on the lower side of the BTSE.

- Refer to the site documentation for the required information about type and location of the 230 V AC connection point.
- The dimensioning of the power supply cable, of the grounding cable and of the magneto-thermal switch must be carried out according to the configuration of the BTSE installation site and with respect for the standards in force in the Country in which the installation takes place.
- Check the actual distance between the shelter and the connection point.
- Cut the cable for the required length.
- Fix wire end sleeves at the end that is to be connected to the connector.
- Lead the prepared cable through the cable access at the bottom of the shelter.
- Insert the prepared ends into the connector. With regard to the connector wiring, consult the instructions contained in the appendix.
- Fix the cable at the cable access by cable strap.
- Lead the main cable to the connection point for 230 V AC.

Note that the type and location of the mains connection point are subject to modification. They are dependent on site and customer requirements. A description of the connecting procedure does not form part of this manual. For further information refer to the site documentation and use the corresponding manufacturer documents.

The BTSE must be connected to the ground system.
For this purpose, there is a 6 mm diameter threaded hole underneath the BTSE.
Connect the BTSE and ground system as follows:

- Use the nearest connection point of the ground system.
- Ascertain the distances between the connection points of the ground system and the ground bolts of the shelter.
- Cut the cable (insulated, 6 mm²) to the required length.
- Remove the cable covering at the end to connect to the ground hole (length approx. 7 mm).
- Fasten a cable terminal to the ground cable and fasten it to the ground hole with a hexagonal head cap screw and 2 washers.
- Connect the prepared cable end to the ground bolt.
- Tighten the nut firmly.

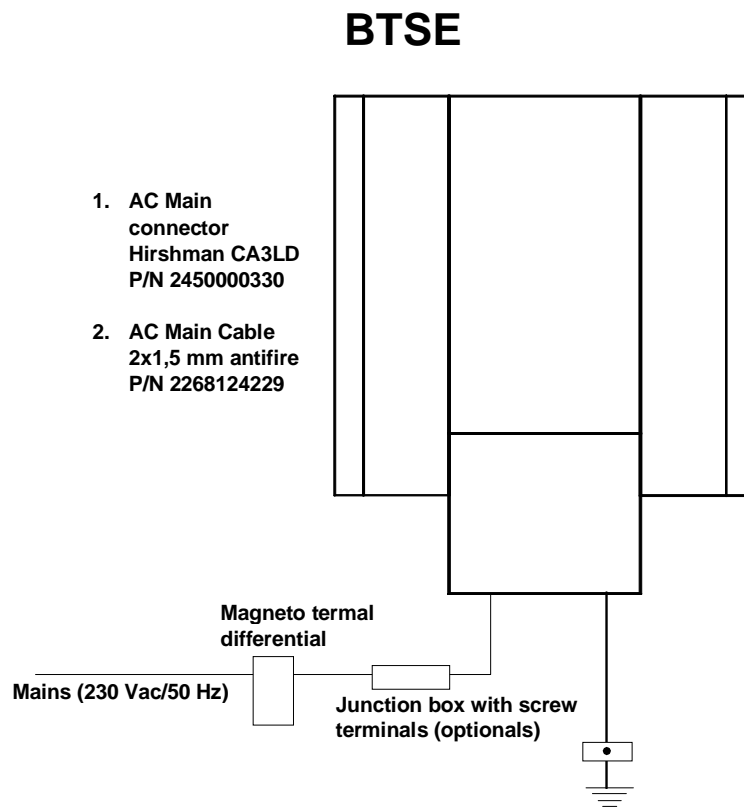

Fig. 3.16. Ground and power supply connections (example)

3.7.2. Abis Interface - PCM 30 Link Equipment

The PCM30 links access the BTSE via the Abis-interface, located at the connection panel (see Fig. 3.15.).

Fig. 3.17. shows three possible Abis configurations to connect the BTSE to the BSC. These configurations are called Star (single), Loop (several in circle) and Multidrop (several).

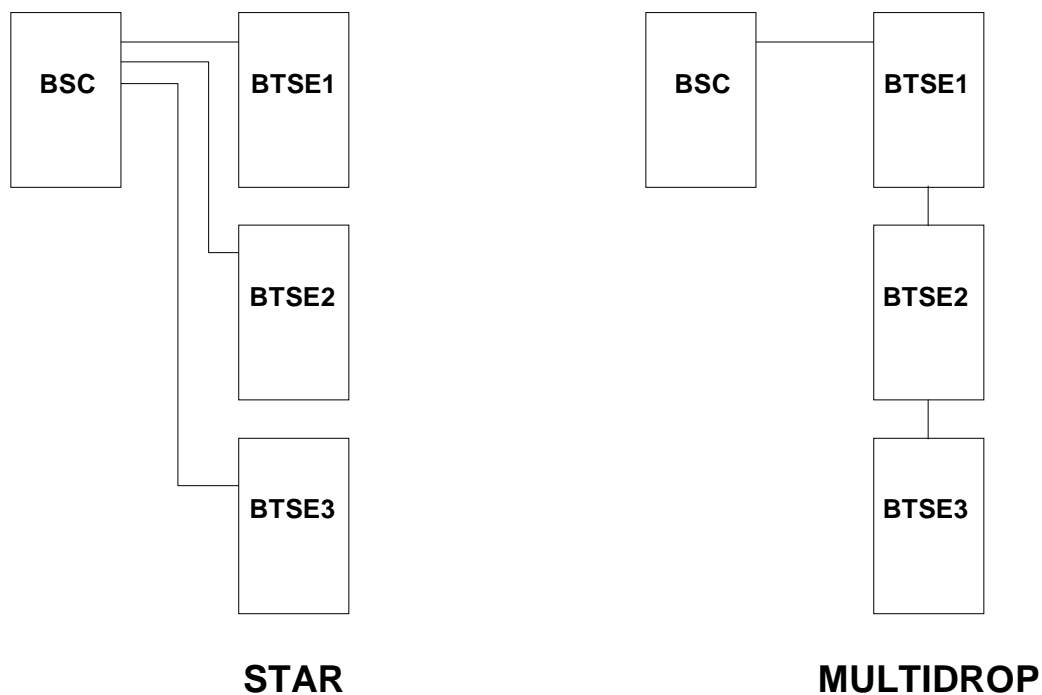

Fig. 3.17. STAR/MULTIDROP Configuration

The functions of the Y01 ÷ Y04 connectors (reception and transmission of the PCM fluxes) are illustrated in Fig. 3.18. ÷ Fig. 3.20.

Connection of the Abis-interface to the PCM 30 link terminal on site is as follows:

- Refer to the site documentation for the required information about the location of the PCM 30 link terminal, the type of shielded cable and of connector, which have to be used.
- Determine the real distance between rack and link terminal.
- Cut the PCM cables to the required length.

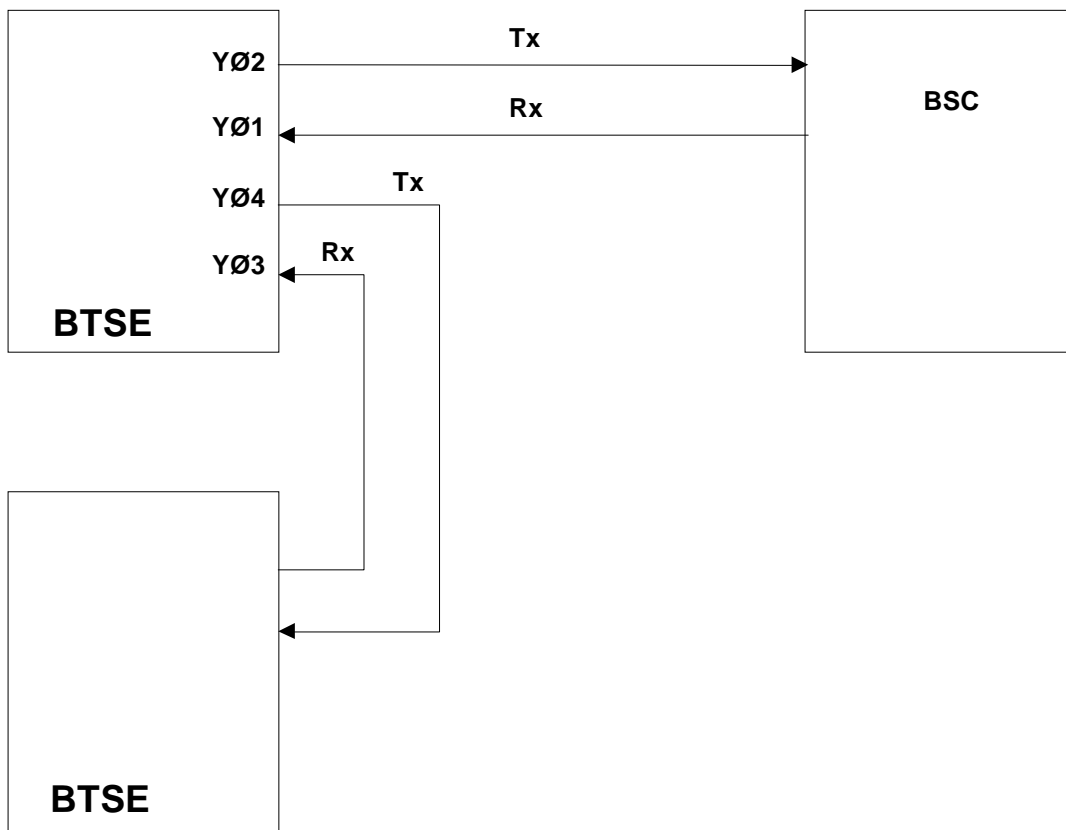

Fig. 3.18. Multidrop configuration Functions of Y01 ÷ Y04 connectors

- With reference to Fig. 3.21., remove the four screws (1) and remove the cover (2) to gain access to the Y01 ÷ Y04 connectors (Fig. 3.22.).
- Insert the four PCM cables in the four holes of the cover removed earlier.
- Abut the PCM cables to the relative connectors (the procedure is shown in the appendix).
- Pass each cable in the respective core hitch.
- Abut the movable connector to the cable.
- Insert the movable connectors in the respective fixed connectors.
- The BTSE is supplied with the output impedance preset to 75 Ω and with the PCM cable shield grounded. Whenever it is necessary to use the output impedance at 120 Ω or to disconnect the ground shield, consult the ITMN:BTSE BS11 manual.

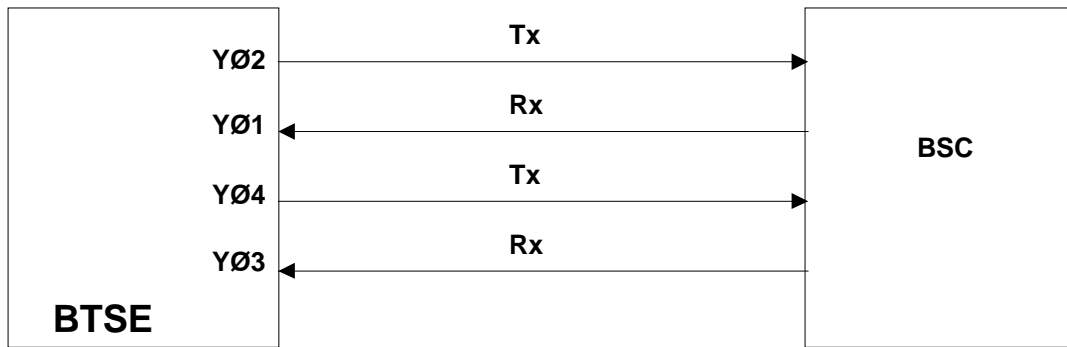

Fig. 3.19. Star configuration Functions of Y01 ÷ Y04 connectors

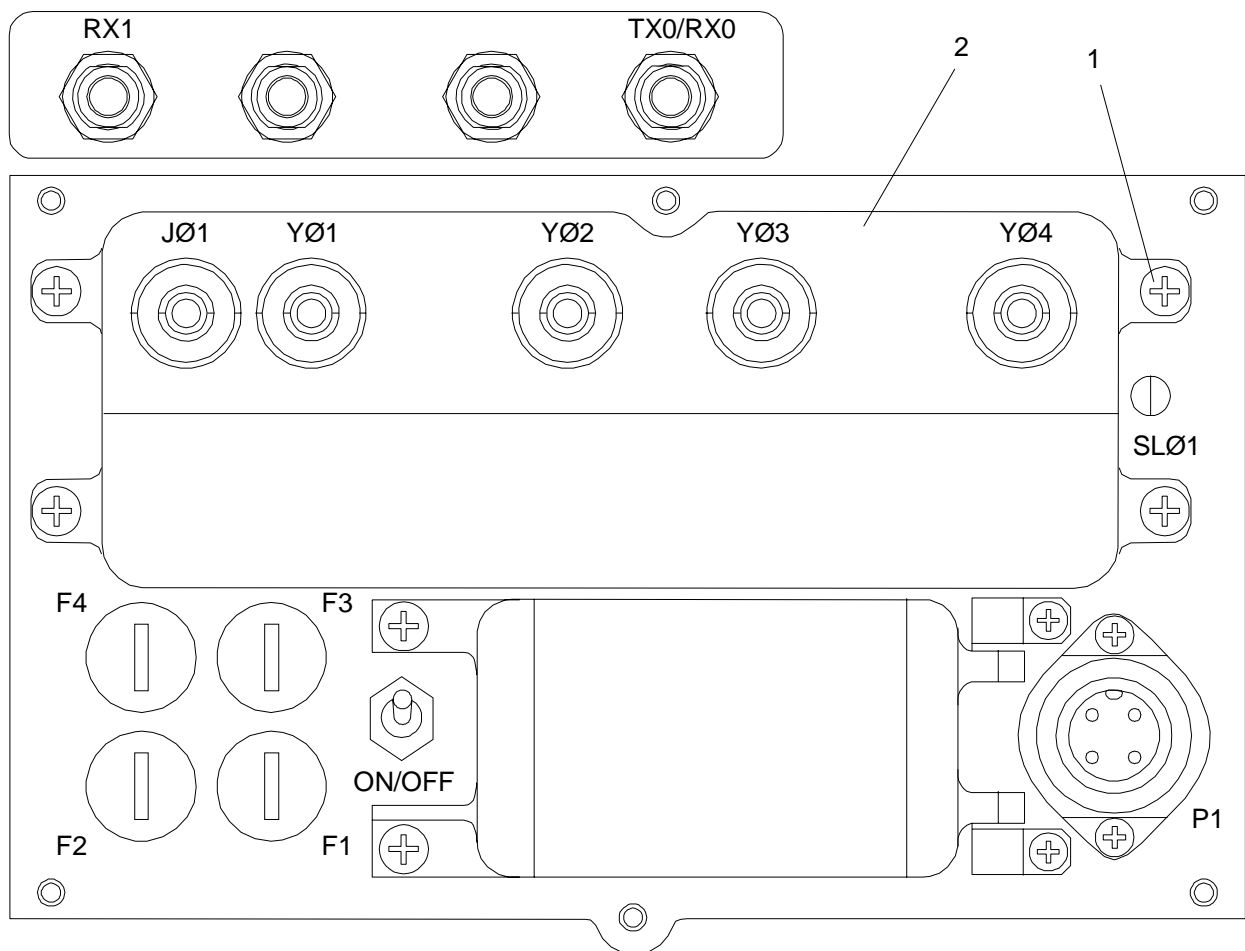
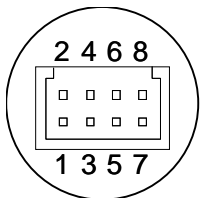
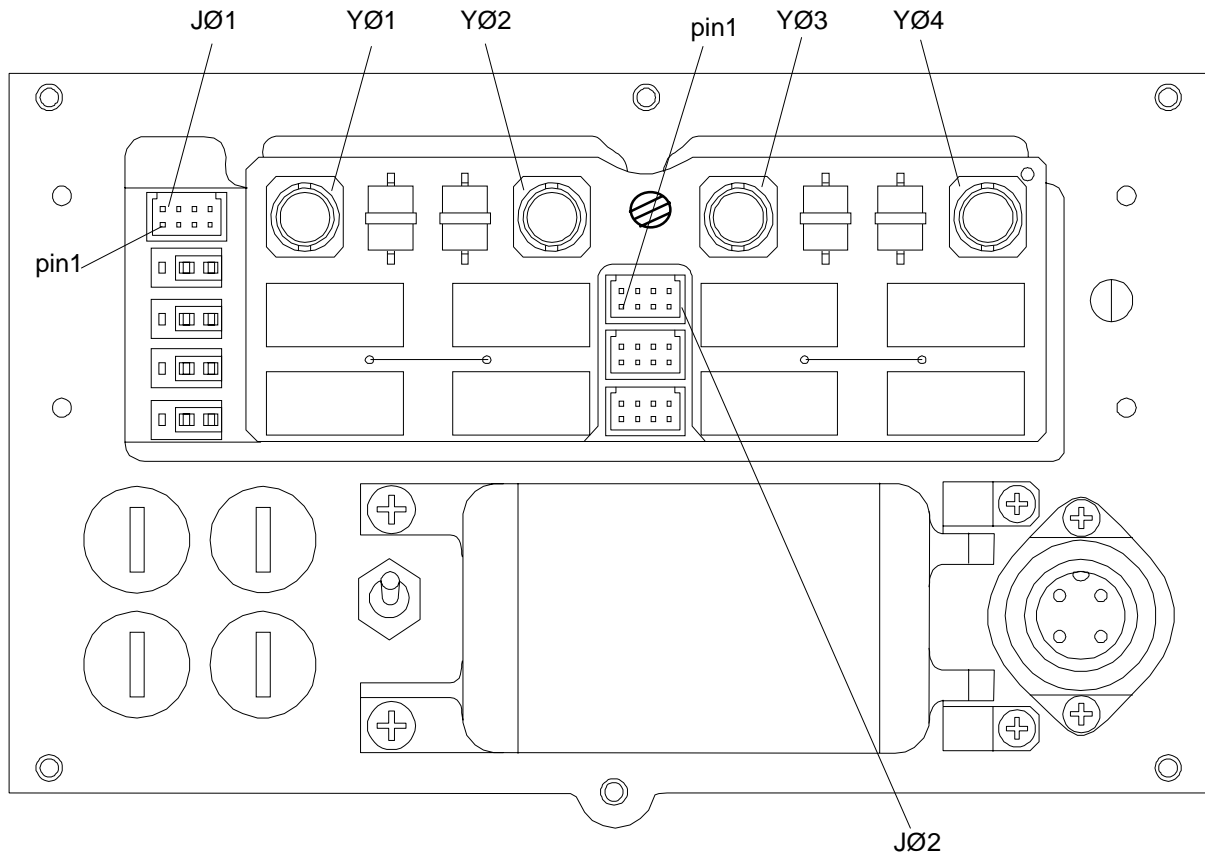

Fig. 3.20. Connection Panel



NOTE: The pin out of JØ1 and JØ2 is in par. 4.6.3

Fig. 3.21. YØ1 ÷ YØ4, JØ1 and JØ2 connectors

3.7.3. Connection to the JØ1 connector

After having connected the PCM30 cables, before closing the connector panel, connect the cable to the flying connector which will then be connected to JØ1.

The operations are described in the appendix.

NOTE: The JØ2 connector serves for the connection with LMT.

3.8. Antenna Connections

The BTSE has to be connected to the transmit and receive antennas according to Fig. 3.23. The antenna configuration and the required cabling are dependent on

the site. The cable pass plate (ref. 11) is shown in fig. 3.24.
For detailed information refer to the site-specific documentation or use the corresponding customer documents. This section gives information about the antenna connections and the connecting procedure of the BTSE.

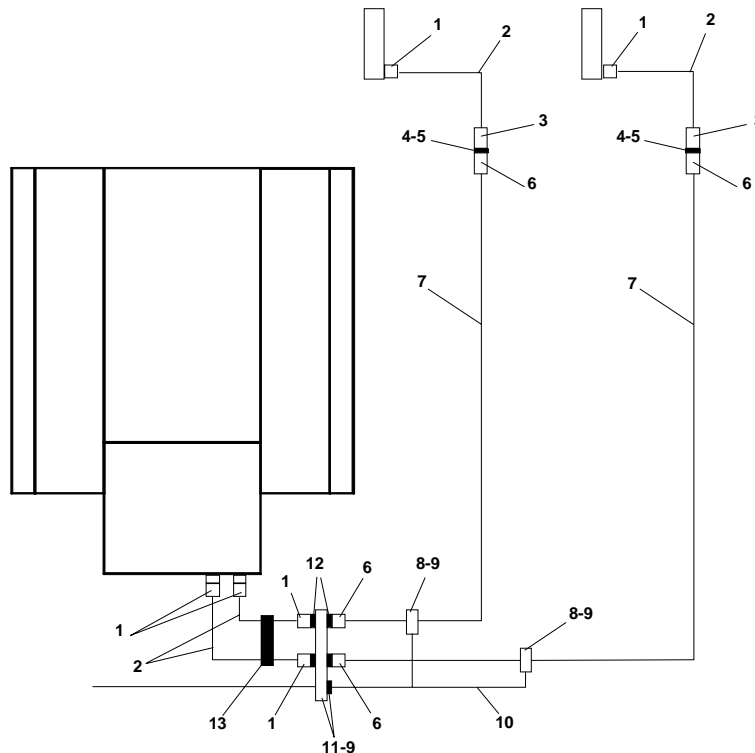

- 1 Coaxial connector mole type N N15015CA N-P/N 24504000018
- 2 Coaxial cable RT 5020
- 3 Coaxial connector female type N N15022C4 G-P/N 24504000025
- 4 Self-agglomerative Rubber tape P/N 20750000206
- 5 Isolation tape PVC P/N 20750000031
- 6 Coaxial connector Male type N for 1/2" cable P/N 24504003077
- 7 Coaxial cable 1/2" P/N 22580000175
- 8 Grounding kit for 1/2" cable P/N 22590000086
- 9 Spade Plug for 6 mm cable P/N 2600440080
- 10 Ground cable 6 mm P/N 22271215152
- 11 Cable pass Plate with ground kit P/N 94287275
- 12 RF Overvoltage Protection Suhner 3400.17.0038 P/N 6047000010
- 13 Tolson neck P/N 20710000538

NOTE: 1) The maximum attenuation of 1 GHz for connection between the BTSE and the aerial antenna system (all included) must be 1.25 dB.

2) The return loss of the aerial antenna system must be at a maximum of 15 dB ($VSWR \leq 1,43$)

Fig. 3.22. Antenna Cabling

The antenna cables access the BTSE via the cable access at the bottom of the BTSE.

For connecting of the BTSE short antenna jumper cables must be prepared on site.

Make sure that the BTSE is self-protected from adjacent structures with regard to the atmospheric discharges in accordance with the standards in force in the Country where it is installed. If the BTSE is not self-protected, a lightning rod must be installed.

Connect the jumper cables as follows:

- Cut the coaxial cable to the required length (distance between the BTSE antenna connectors and the ends of the antenna feeder cables).
- Fix a N-type angle connector (male) at the end to be connected with the antenna connectors.
- Fix a N male connector at the end to be connected with the antenna feeder cable.
- Lead the jumper cable via the cable access to the antenna connector. Pay attention to the minimum bending radius of the cable.
- After fixing of the jumper cable at the antenna connector, use a cable strap for cable fixing at the cable access.
- The TX / RX antenna must be connected to TX 1 connector and RX antenna to RX 2 connector.
- We recommend placing the lightning discharge and the passage between the antenna cable and the antenna down lead on the interconnection plate.

3.8.1. Antenna System Fulmination Protection

After having installed the antenna as indicated earlier, it is necessary to verify if the structure is self-protected. Refer to European standards in effect in the Country where the installation is carried out regarding fulmination protection. If not, the antenna must be grounded by a system carried out according to the standards in force. Use 1/4 shorting stub by SYHNER or M/A-COM.

3.8.2. Antivandalism Protection

It is necessary to protect the cables with stainless steel or zinc-coated tubes or with steel tubes covered with a steel and transparent PVC braid.

3.8.3. Cable Down-Leads

Always keep the feeders separate from the signal cables by means of separate raceways.

Furthermore, ground the braid of the antenna cable at the beginning and at the end of the lead-in.

Use 1/2", 7/8" or Heliac type cables for the antenna lead-in, depending on the distance between the antenna and the BTSE.

3.8.4. Interconnection Plate

Position the interconnection plate (not supplied) as close as possible to the BTSE (Fig. 3.25.) and then carry out the connections between the antenna cables and

the interconnection plate and between the interconnection plate and the BTSE.
Then ground the plate.

The interconnection plate is not supplied.

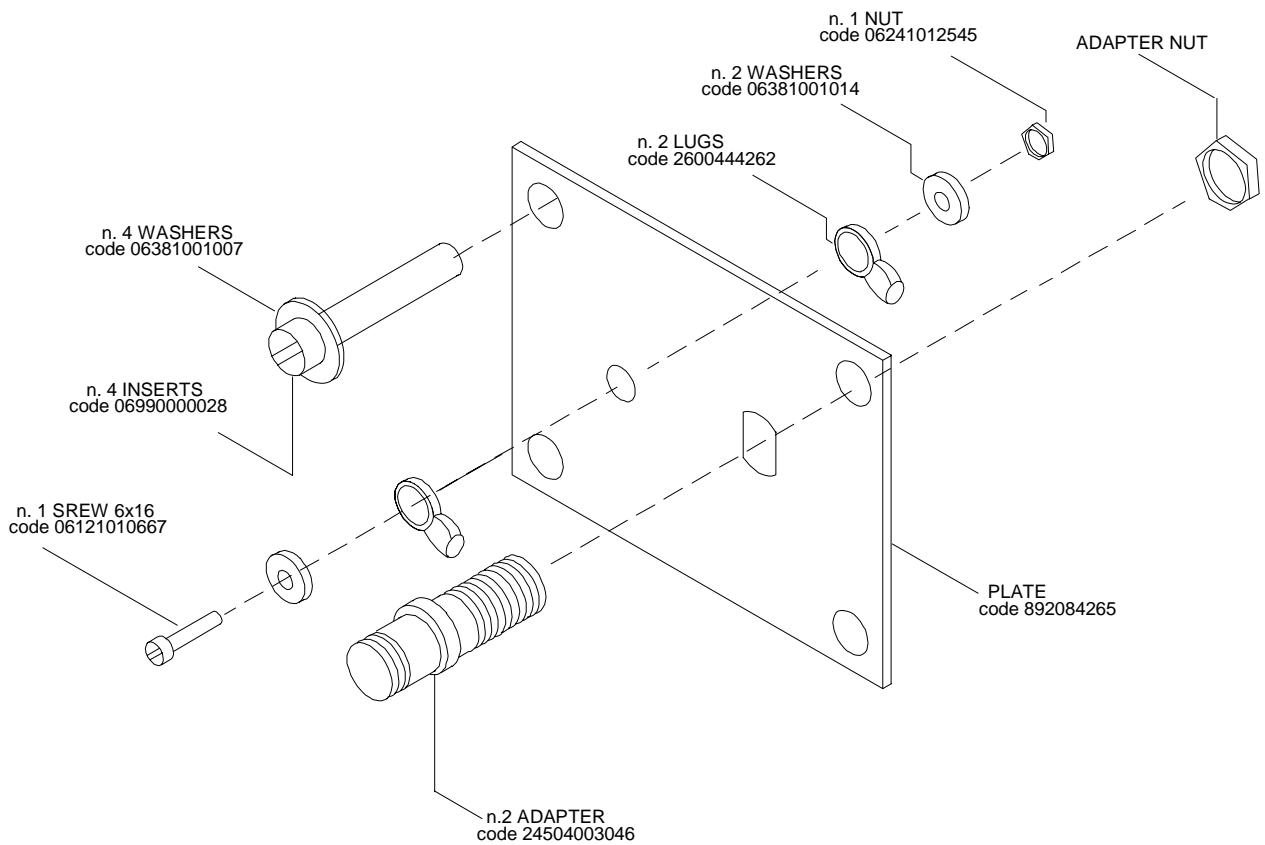

Fig. 3.23. Cable Pass Plate

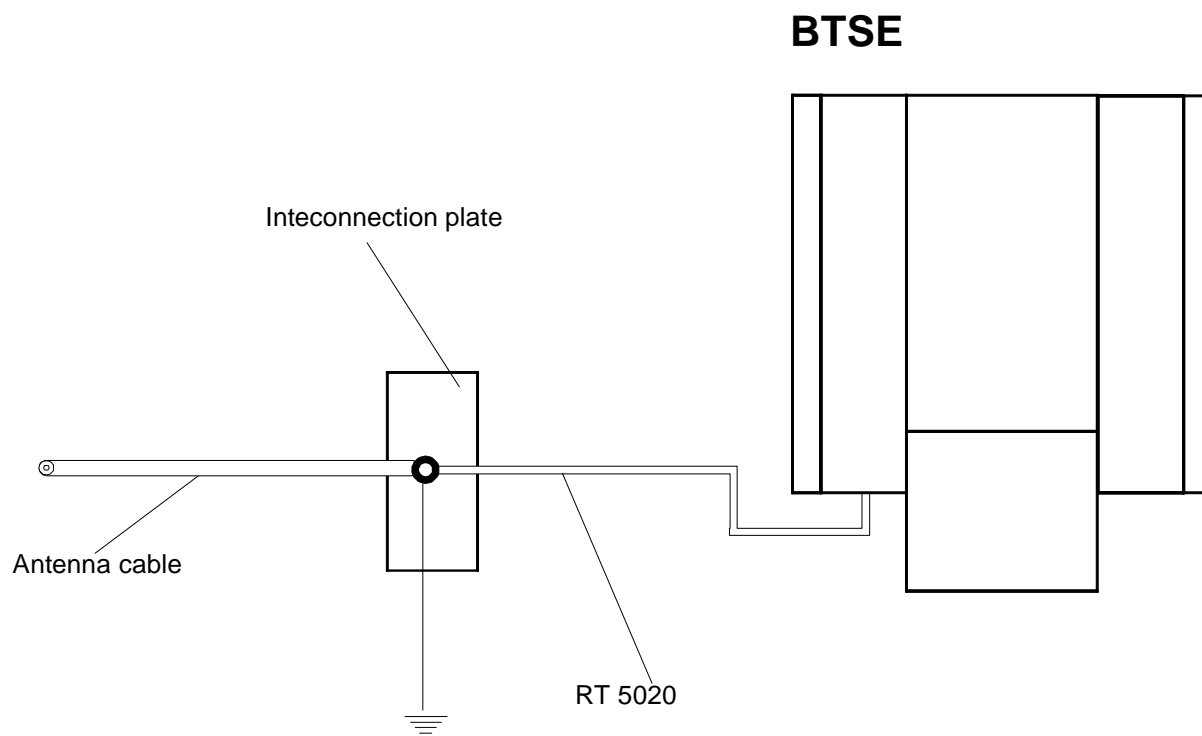

Fig. 3.24. Interconnection Plate

3.9. Post Installation Notes

After all installation works are finished and all cables clamped at the cable access, close the cable entry box (2, Fig. 3.21.).

Close the connector panel cover using the proper wrench.

Remove all packing material from site.

Call the commissioning staff for switch on, testing and network integration of the Base Station.

4. Appendix

4.1. AC Main Connector

4.1.1. Connector type

Type: Hirshmann CA 3 LD 09 ZS

OTE code: 24550000347

4.1.2. General view

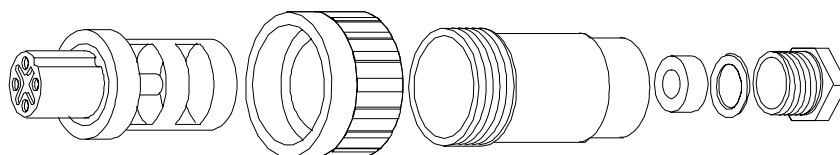

4.1.3. Dimensions (mm)

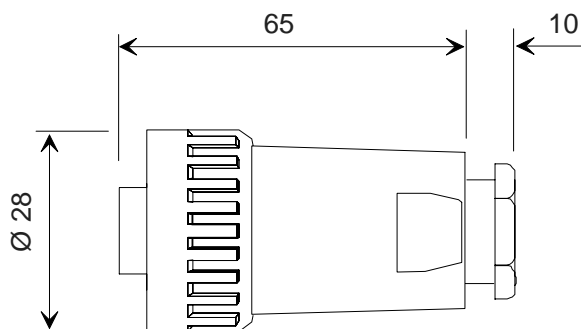

4.1.4. Technical characteristics

- | | |
|---------------------------------|-----------------|
| - Insulation group DIN VDE 0110 | C |
| - Continuous load current | 16 A AC/10 A DC |
| - Contact resistance | 3 mΩ |
| - Pin diameter | 2 mm |
| - Type of connection | screw |
| - Cable gland | Pg 9, Pg 13,5 |

- Outer lead diameter 6....12 mm
- Max lead cross-section 1,5 mm²/AWG 16
- Flammability UL standard 94 V - 0
- Protection class DIN 40 050 IP 65
- Ambient temperature range 40°C ÷ 90°C

4.1.5. Materials

- Contact material/surface CuZn/silver plate
- Contact beard PA 66-GF 25
- Casing PA 66-GF 25
- Sealing ring NBR

4.1.6. Pinning of Power Supply Socket

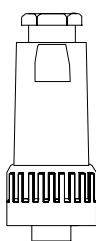
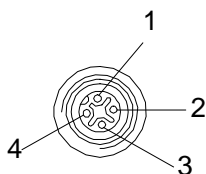

- 1 Phase
- 2 GND
- 3 Phase
- 4 Shield

4.1.7. Mounting of the cable-Movable socket

- Insert the cable fastener, the extension, the ring nut and the other connector components on the cable (section 4.1.1).
- Cut the external cable sheath for a length of approx. 10 cm.
- Remove the conductor covering
- Carry out the connections indicated in section 4.1.2.
- Tighten the connector components.
- Connect the flying connector to the P1 connector

4.2. PCM Connector

4.2.1. Straight connector type

For cables with $6 \div 6.4$ mm diameter

Type: Radiall R 605006

OTE code: 24508000430

For cables with $5 \div 5.5$ mm diameter

Type: Radiall R 605005

4.2.2. General view

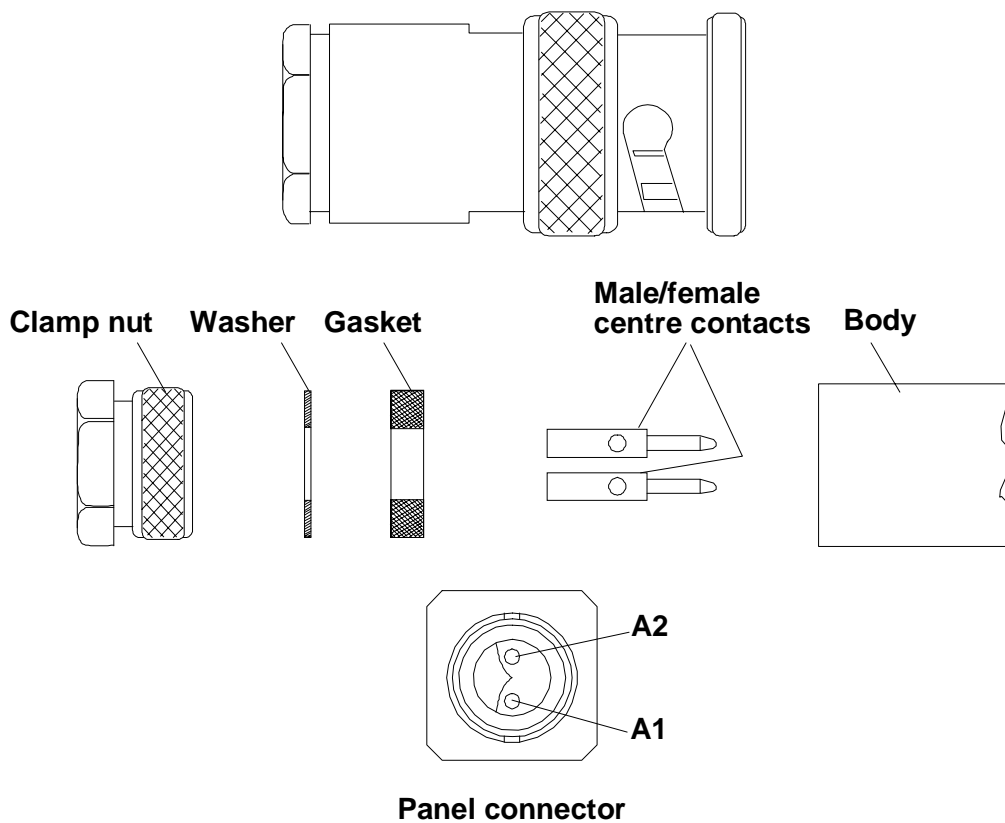

4.2.3. Dimensions (mm)

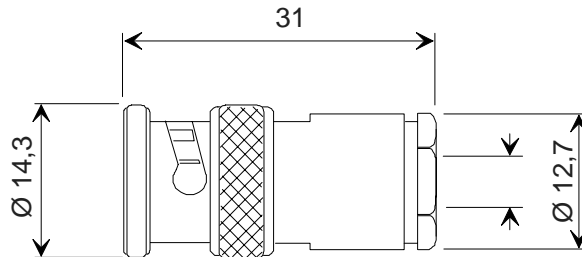

4.2.4. General view

- Characteristic impedance 50 Ohm
- Operating frequency range to 10000 Mhz
- Test voltage:

	Unmated connector	Mated pair
Between centre conductor and inner screen	1500 V.rms	3000 V.rms
Between inner screen and outer screen	1000 V.rms	1000 V.rms
- Temperature range -55°C ++125°C

4.2.5. Mounting of cable on connector

- Strip the cable (dimensions in mm).



- Slide the clamp nut, the large diameter washer and gasket onto the cable.

4.2.6. Connections

75 W coax

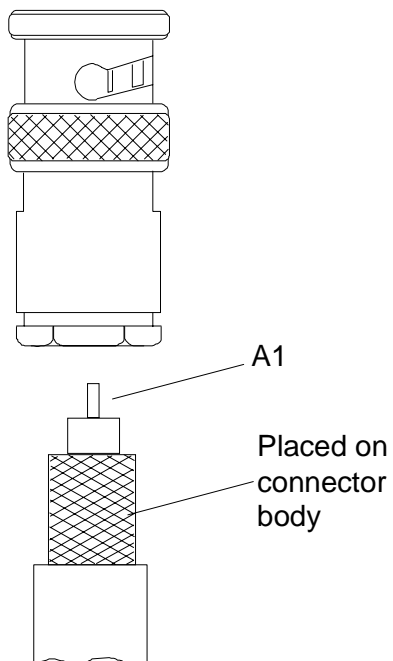

- Connect only A1
- Connect the shield to the connector body.

120 W twisted pair with shield cable

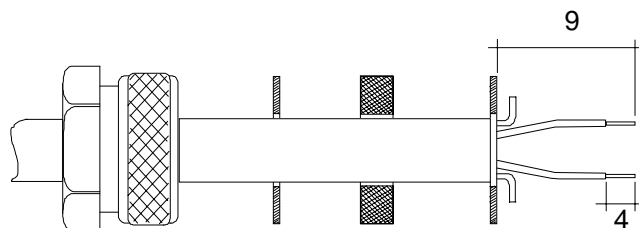

- Slide smaller diameter washer until it bottoms against cable jacket.
- Fold back braid and trim to outside diameter of washer.
- Trimback dielectric as shown.

- Slide smaller diameter washer and the separator.

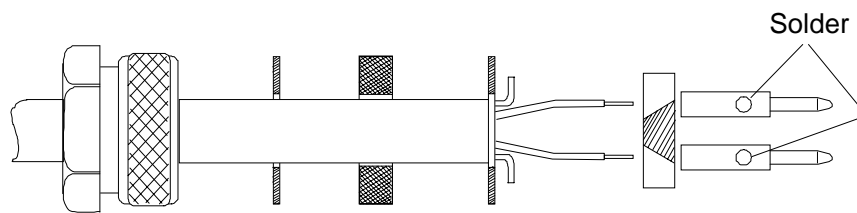

- Solder centre contacts on to inner conductor.
- Screw sub-assembly into the connector body (recommended coupling torque: 450 cm. N).

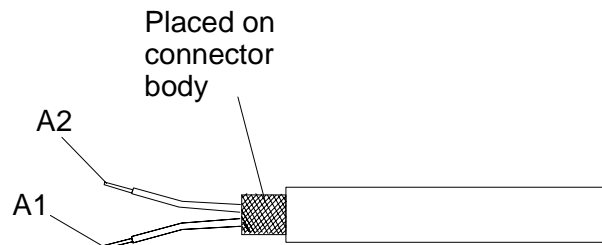
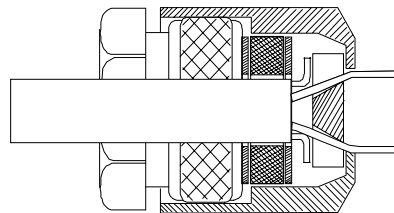

- Connect A1 and A2.
- Connect the shield to the connector body.

4.3. RF Connector Type N N15015 C4 GN-1

4.3.1. Connector type

Coaxial Connector Male for cable RT 5020 (RG 214)

Type: N N15015C4 GN-1

OTE code: 24504000018

4.3.2. General view

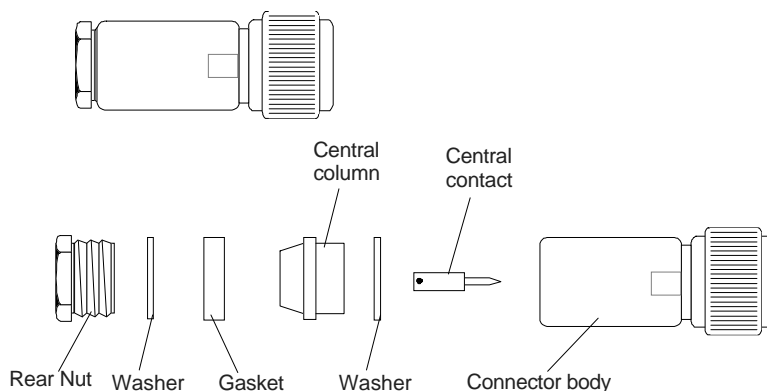

4.3.3. Dimensions (mm)

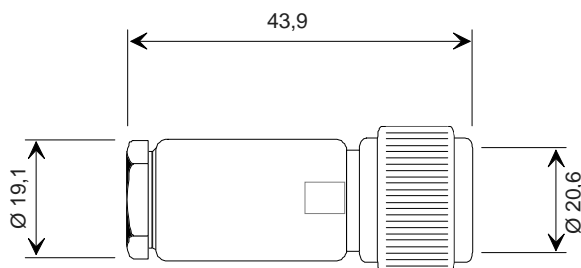

4.3.4. Technical characteristics

- Characteristic impedance	50 Ohm
- Frequency range	DC÷11 GHz
- Insertion loss	<0,15 dB at 10 GHz
- Working voltage	1000 Veff/50 Hz
- Insulation voltage	2500 Veff/50 Hz
- Insulation resistance	>5000 MOhm
- Contact resistance	1 Mohm (central contact) 0,25 Mohm (external contact)
- Temperature range	-65°C÷+165°C
- Maximum power	1000 W (DC÷100MHz) 300 W (101 MHz÷ 1000 MHz) 150 W (1001 MHz÷3000 MHz)

4.3.5. Materials

- | | |
|---------------------------|----------------------------------|
| - Contacts and interfaces | Beryllium bronze |
| - Other metallic parts | Brass (nickel or silver treated) |
| - Sealing rings | Silicon rubber |
| - Insulating parts | PTFE |
| - Central contacts | Gold plated |

4.4. RF Connector Type N N15022 C4 G-1

4.4.1. Connector type

Coaxial Connector Female for cable RT 5020

Type: N N15022 C4 G-1

OTE code: 24504000025

4.4.2. General view

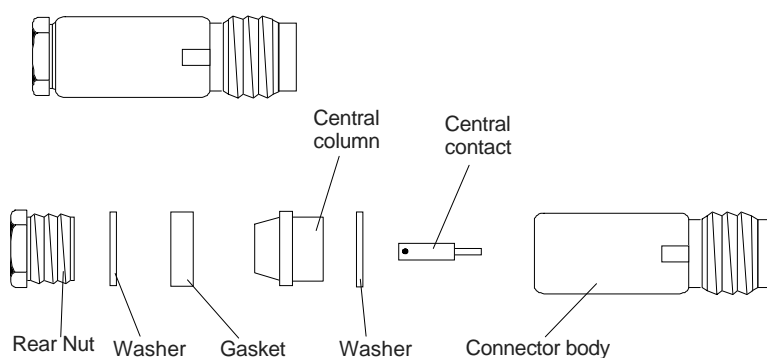

4.4.3. Dimensions (mm)

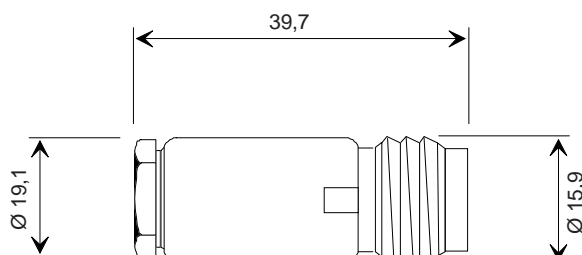

4.4.4. Technical characteristics

- Characteristic impedance	50 Ohm
- Frequency range	DC÷11 GHz
- Insertion loss	<0,15 dB at 10 GHz
- Working voltage	1000 Veff/50 Hz
- Insulation voltage	2500 Veff/50 Hz
- Insulation resistance	>5000 MOhm
- Contact resistance	1 Mohm (central contact) 0,25 Mohm (external contact)
- Temperature range	-65°C÷+165°C
- Maximum power	1000 W (DC÷100MHz) 300 W (101 MHz÷ 1000 MHz) 150 W (1001 MHz÷3000 MHz)

4.4.5. Materials

- Contacts and interfaces	Beryllium bronze
- Other metallic parts	Brass (nickel or silver treated)
- Sealing rings	Silicon rubber
- Insulating parts	PTFE
- Central contacts	Gold plated

4.5. RF Connector Type N for 1/2" cable

4.5.1. Connector type

Coaxial Connector Male

Type: N for 1/2" cable

OTE code: 24504003077

4.5.2. General view

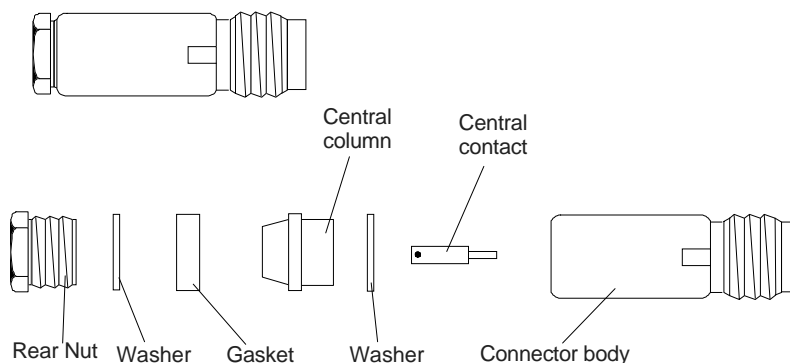

4.5.3. Dimensions (mm)

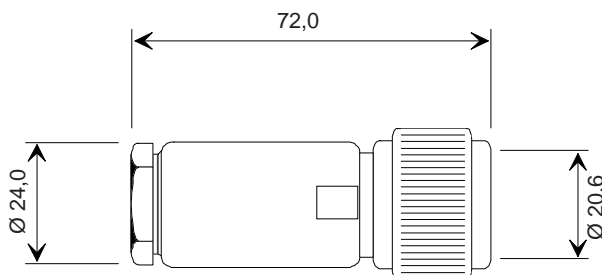

4.5.4. Technical characteristics

- Characteristic impedance 50 Ohm
- Frequency range DC÷11 GHz
- Insertion loss <0,15 dB at 10 GHz
- Working voltage 1000 Veff/50 Hz
- Insulation voltage 2500 Veff/50 Hz
- Insulation resistance >5000 MOhm
- Contact resistance 1 Mohm (central contact)
0,25 Mohm (external contact)
- Temperature range -65°C÷+165°C
- Maximum power 1000 W (DC÷100MHz)
300 W (101 MHz÷ 1000 MHz)
150 W (1001 MHz÷3000 MHz)

4.5.5. Materials

- | | |
|---------------------------|----------------------------------|
| - Contacts and interfaces | Beryllium bronze |
| - Other metallic parts | Brass (nickel or silver treated) |
| - Sealing rings | Silicon rubber |
| - Insulating parts | PTFE |
| - Central contacts | Gold plated |

4.6. Alarm Connector

4.6.1. Connector type

Type: AMP MODU II 280365

4x2 in double file

OTE code: 24301000266

You need also 8 contacts for each connector (OTE code: 24320000010).

4.6.2. General view

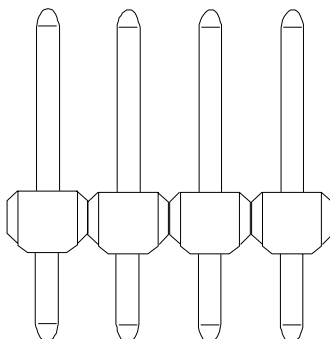
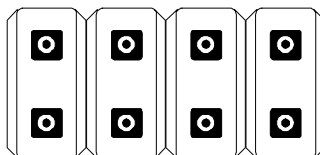

4.6.3. Pinning of J01 and J02 connector

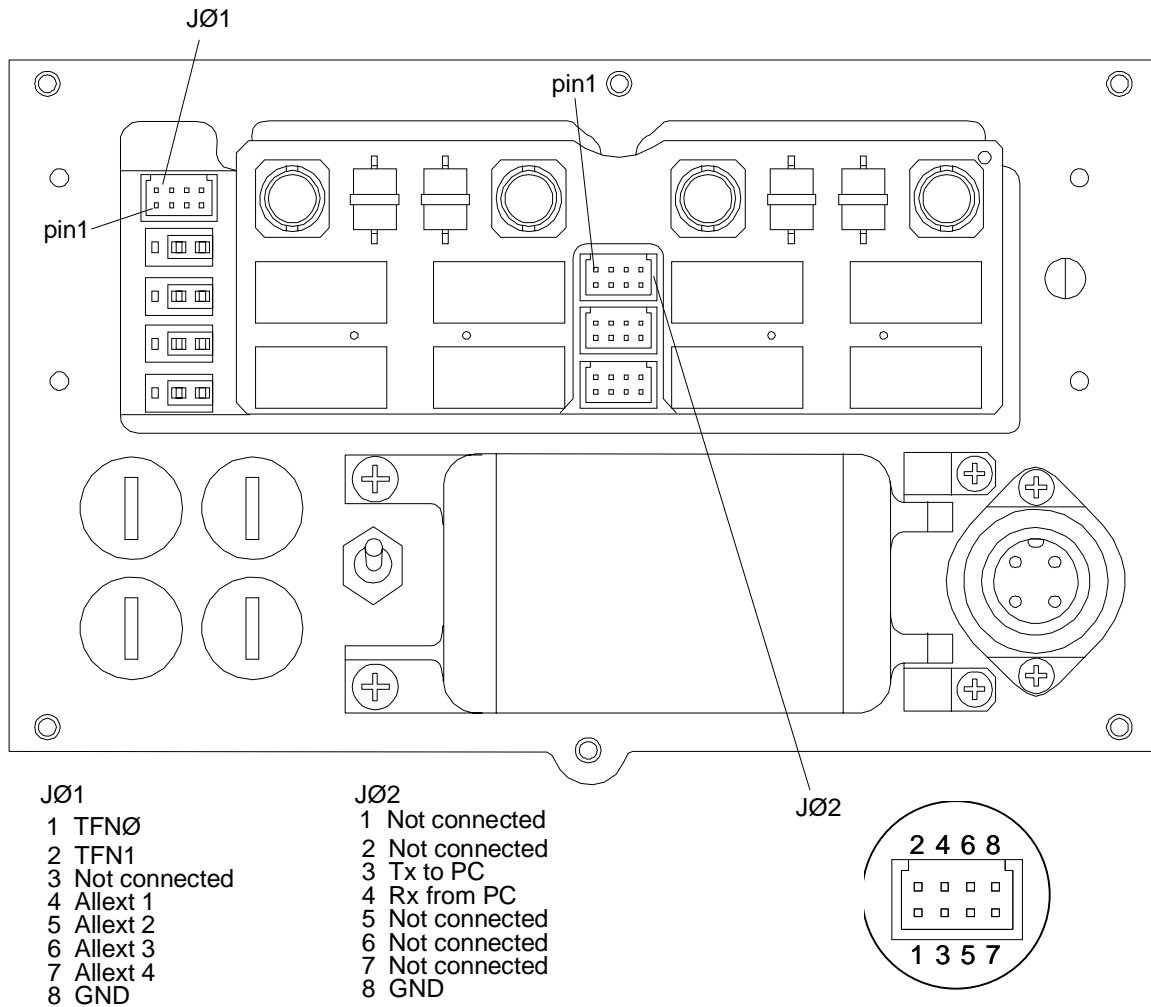

4.6.4. Mounting of the straight cable socket

- Strip the cable conductors (for J01 and J02) approx. 3 mm.
- Crimp the contacts to the conductors (8 for each cable).
- Insert the contact of the contactor until locked in place.
- Insert a thermo-tightening sheath between the connector and the cable.

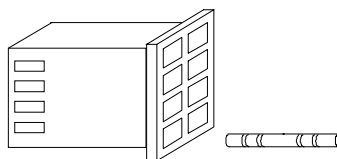

4.7. Coaxial Cables

4.7.1. ½" cable (OTE code: 22580000175)

Technical characteristics

- Impedance 50 Ohm
- Maximum work voltage 1590 V
- Attenuation at 0,5 GHz 5 dB / 100 mt

Dimensions

- Core conductor Ø 4,9 mm
- Dielectric Ø 11,6 mm
- Outer tubular conductor Ø 13,7 mm
- Outer sheath Ø 16 mm

Materials

- Core conductor Copper
- Dielectric Foam PE
- Outer tubular conductor Copper
- Outer sheath Polyethylene (black)

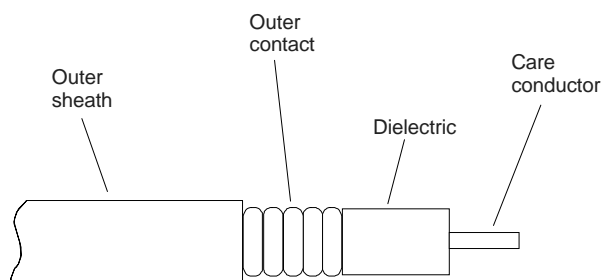

4.7.2. Cable RT 5020

Technical characteristics

- Impedance 50 Ohm ± 2
- Attenuation at 900 MHz 9 dB / 100 mt

Dimensions

- Core conductor Ø 26 mm

- Dielectric \varnothing 7,1 mm
- Outer sheath \varnothing 10,3 mm

Materials

- Core conductor Copper
- Dielectric Cellular polyethylene (PES)
- Outer conductor Copper (n° 2 shields)
- Outer sheath Polyethylene (PE)

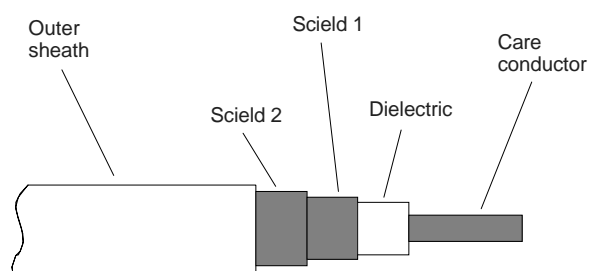

4.8. Alarm Cable (OTE Code 22401200528)

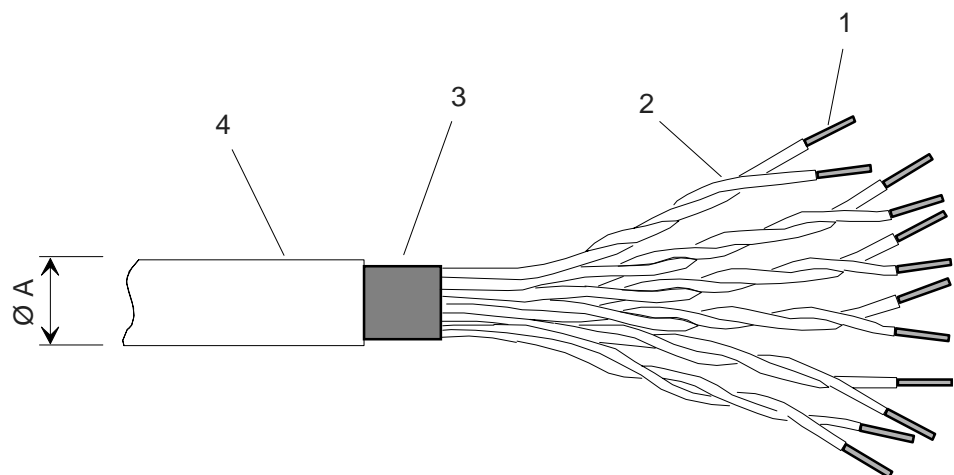

1. Flexible wire 18x0,1 (normal section = 0,14 mm² AWG26), material tinning copper insulated PVC (gage of the insulated = 0,3), major diameter wire = 1,15 mm.
2. Couple wires to helix lacing, lead 30÷40 mm with distribution colours of the wire are listed us follows:
Colours of the couple wires:

Violet - orange

Grey - brown

Pink - black

White - red

3. Braided wire to cotton or rayon
4. Blanket insulation to PVC (colour grey) gage 0,7 mm.

Conductor number	:	8 (4 couple)
Diameter	:	6 : 6,5
Voltage rating	:	250 Vcc
Voltage test	:	1000 Vrms
Minimum bend radius	:	2x major diameter

4.9. Radio Frequency Cables Assembly

4.9.1 1/2" Cable Assembly to type "N" connectors (dimensions in mm)

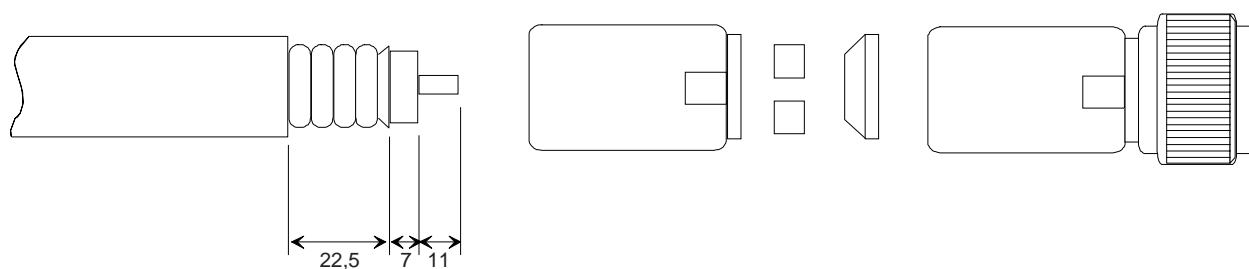

4.9.2 RT 5020 Cable Assembly

Instructions

1. Glide clamp nut and plain gasket over cable and trim outer sheath from cable as shown.

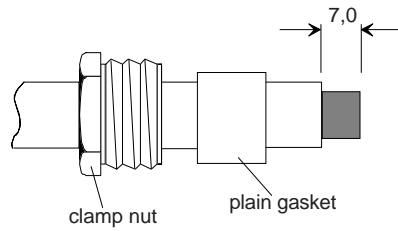

2. Fold back braid and push ferrule over dielectric to trap braid between outer sheath and ferrule. Trim off surplus braid.

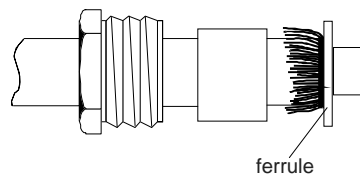

3. Trim back dielectric and check the length of the centre conductor.

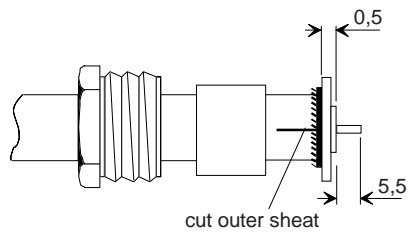

4. Tin centre conductor, then slide rear insulator over dielectric to bull against ferrule.

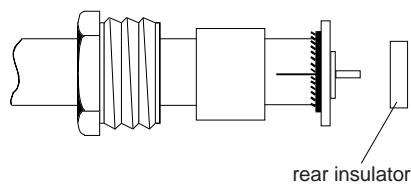

5. Fit contact (male for plugs, female for jack) onto centre conductor. Hold cable and contact tightly together and solder

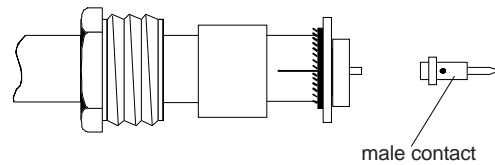

6. Slide plain gasket and clamp nut up to ferrule trapping braid. Fit front insulator over contact to butt against rear isolator and press sub-assembly into body as far as possible.

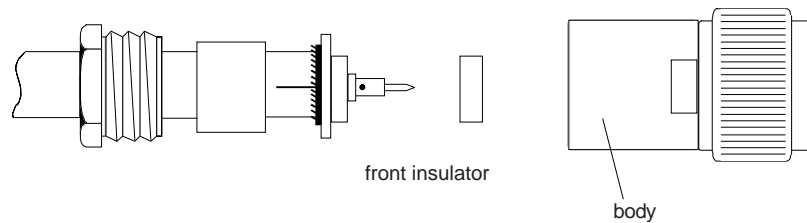

7. Engage and tighten clamp nut.

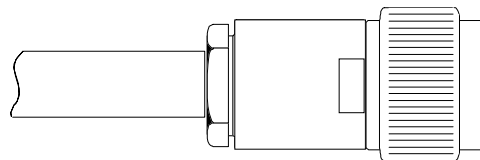

NOTE: a plug body is shown, but these instructions are relevant to both plugs and jack. The characteristics of the contacts and insulator may vary from the drawings shown.

4.10. LMT Cable for BTSE

4.10.1. Composition of LMT Cable

- Connector AMP MODU II type female for crimp contacts (quantity 1, code MSPA 67263-10/044)
- Female crimp contacts AMP (quantity 3, code MSPA 67263-10/101)

- Female connectors 9 wais without contacts (quantity 1,code MSPA 67316-12/002)
- Female contact AWG 24/28 (quantity 3,code MSPA 67316-12/053)
- Plastic cap for connector (quantity 1,code MSPA 67316-60/019)
- 4 Pairs not shielded cable (quantity 2.5m,code MSPA 55650-11/002)

4.10.2. General view

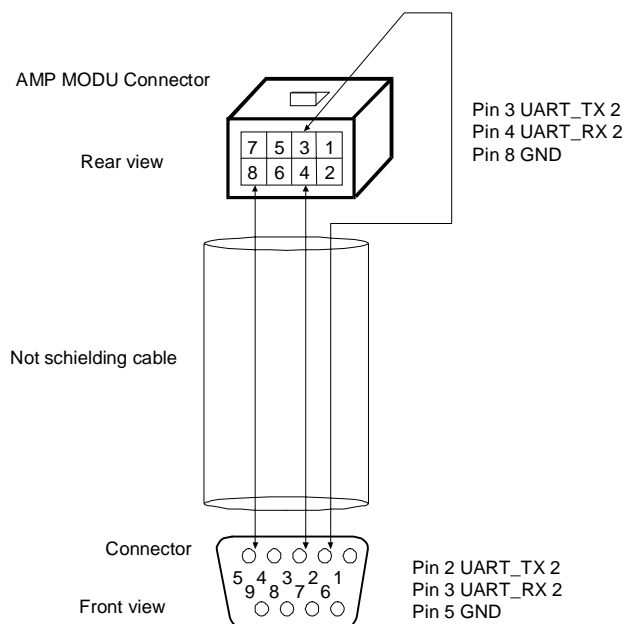

5. Abbreviations

BS-11e/900.1	BTSE with external antenna and single TRX
BS-11i/900.1	BTSE with integrated antenna and single TRX
BSC	Base Station Controller
BSS	Base Station System
D900	Siemens BSS 900 MHz
GSM	Global System for Mobile communications
IMN	Installation Manual
IMN	Installation Manual
LMT	Local Maintenance Terminal
LNA	Low Noise Amplifier
MBBCU	MultiBand Base Central Unit
BTSE	Base Transceiver Station Equipment
MS	Mobile Station
OMC	Operation and Maintenance Center
PA	Power Amplifier
PCM	Pulse Code Modulation
PSU	Power Supply Unit
RX	Receiver
SVR	System Version Release
SW	Software
TCH	Traffic Channel
TRAU	Transcoding and Rate Adaptation Unit
TX	Transmitter
UMN	User's Manual