

Introduction

The Automated Acceptance Test Procedure (ATP) allows Cellular Field Engineers (CFEs) to run automated acceptance tests on all equipped BTS subsystem devices using the Local Maintenance Facility (LMF) and supported test equipment per the current Cell Site Data File (CDF) assignment.

The results of these tests (at the option of the operator) are written to a file that can be printed. All tests are controlled from the LMF platform using the GPIB interface, therefore, only recommended test equipment supported by the LMF can be used.

This chapter describes the tests run from the GUI environment, which is the recommended method. The GUI provides the advantages of simplifying the LMF user interface, reducing the potential for miskeying commands and associated parameters, and speeding up the execution of complex operations involving multiple command strings. If you feel the command line interface (CLI) will provide additional insight into the progress of ATPs and problems that could possibly be encountered, refer to *LMF CLI Commands, R15.X (68P09251A59)*.



IMPORTANT

Before performing any tests, use an editor to view the “CAVEATS” section of the “readme.txt” file in the c:\wlmf folder for any applicable information.

The ATP test is to be performed on out-of-service (OOS) sectors *only*.

DO NOT substitute test equipment not supported by the LMF.

NOTE

Refer to Chapter 3 for detailed information on test set connections for calibrating equipment, cables and other test set components, if required.

Customer requirements determine which ATP tests to are to be performed, and the craftsperson selects the appropriate ATP tests to run.

The tests can be run individually or as one of the following groups:

- **All TX:** TX tests verify the performance of the BTS transmit line up. These include the GLI, MCC, BBX, and CIO cards, the LPAs and passive components including splitters, combiners, bandpass filters, and RF cables.
- **All RX:** RX tests verify the performance of the BTS receiver line up. These include the MPC (for starter frames), EMPC (for expansion frames), CIO, BBX, MCC, and GLI cards and the passive components including RX filters (starter frame only), and RF cables.

. . . continued on next page

- **All TX/RX:** Executes all the TX and RX tests.
- **Full Optimization:** Executes the TX calibration, downloads the BLO, and executes the TX audit before running all of the TX and RX tests.

ATP Test Prerequisites

Before attempting to run any ATP tests, ensure the following have been completed:

- BTS has been optimized and calibrated (see Chapter 3).
- LMF is logged into the BTS.
- CSMs, GLIs, BBXs, MCCs, and TSU (if the RFDS is installed) have correct code load and data load.
- Primary CSM, GLI, and MCCs are INS_ACT.
- BBXs are calibrated and BLOs are downloaded.
- BBXs are OOS_RAM.
- Test cables are calibrated.
- Test equipment is connected for ATP tests (see Figure 3-13 through Figure 3-16 starting on page 3-50).
- Test equipment has been warmed up 60 minutes and calibrated.
- GPIB is on.



WARNING

Before performing the FER, be sure that all LPAs are turned OFF (circuit breakers pulled) or that all transmitter ports are properly terminated.

All transmit ports must be properly terminated for all ATP tests.

Failure to observe these warnings may result in bodily injury or equipment damage.

TX OUT Connection



IMPORTANT

Many of the acceptance test procedures require taking measurements at the **TX OUT** (BTS/RFDS) connector. At sites without RFDS installed, all measurements will be via the BTS **TX OUT** connector. At sites with RFDS installed, all measurements will be via the RFDS directional coupler **TX OUT** connector.

ATP Test Procedure

There are three different ATP testing options that can be performed to completely test a BTS. Depending on your requirements, one of the following ATP testing options should be run.

- ATP Testing Option 1
 - All **TX/RX**
- ATP Testing Option 2
 - All **TX**
 - All **RX**
- ATP Testing Option 3
 - **TX Mask** Test
 - **Rho** Test
 - **Pilot Time Offset** Test
 - **Code Domain Power** Test
 - **FER** Test

NOTE

The Full Optimization test can be run if you want the TX path calibrated before all the TX and RX tests are run.



IMPORTANT

If manual testing has been performed with the HP analyzer, remove the manual control/system memory card from the card slot and set the **I/O Config** to the **Talk & Lstn** mode before starting the automated testing.

Follow the procedure in Table 4-1 to perform any ATP test.

NOTE

The **STOP** button can be used to stop the testing process.

Table 4-1: ATP Test Procedure		
	Step	Action
	1	Select the device(s) to be tested.
	2	From the Tests menu, select the test you want to run.
	3	Select the appropriate carrier(s) (carrier-bts#-sector#-carrier#) displayed in the Channels/Carrier pick list. NOTE To select multiple items, hold down the <Shift> or <Ctrl> key while making the selections.

. . . continued on next page

Table 4-1: ATP Test Procedure

✔	Step	Action
	4	Enter the appropriate channel number in the Carrier n Channels box. The default channel number displayed is determined by the CdmaChans[n] number in the cbse-n.cdf file for the BTS.
	5	Click on the OK button. The status report window and a Directions pop-up are displayed.
	6	Follow the cable connection directions as they are displayed. The test results are displayed in the status report window.
	7	Click on Save Results or Dismiss . NOTE If Dismiss is used, the test results will not be saved in the test report file.

4

TX Output Acceptance Tests: Introduction

Individual Acceptance Tests

The following individual tests can be used to verify the results of specific tests.

Spectral Purity TX Mask (Primary & Redundant BBX)

This test verifies that the transmitted CDMA carrier waveform generated on each sector meets the transmit spectral mask specification with respect to the assigned CDF file values.

Waveform Quality (rho)

This test verifies that the transmitted Pilot channel element digital waveform quality (rho) exceeds the minimum specified value in ANSI-J STD-019. “*Rho*” represents the correlation between actual and perfect CDMA modulation spectrum. A rho value of 1.0000 represents 100% (or perfect correlation).

Pilot Time Offset

The Pilot Time Offset is the difference between the CDMA analyzer measurement interval (based on the BTS system time reference) and the incoming block of transmitted data from the BTS (Pilot only, Pilot Gain = 262, PN Offset = 0).

Code Domain Power (Primary & Redundant BBX)

This test verifies the code domain power levels, which have been set for all ODD numbered Walsh channels, using the OCNS command. This is done by verifying that the ratio of PILOT divided by OCNS is equal to 10.2 ± 2 dB, and, that the noise floor of all EVEN numbered “OFF” Walsh channels measures ≤ -27 dB (with respect to total CDMA channel power).

Frame Error Rate

The Frame Error Rate (FER) test verifies RX operation of the entire CDMA Reverse Link using all equipped MCCs assigned to all respective sector/antennas. This test verifies the BTS sensitivity on all traffic channel elements currently configured on all equipped MCCs at an RF input level of -119 dBm (or -116 dBm if using TMPC).

TX Spectral Purity Transmit Mask Acceptance Test

Tx Mask Test

This test verifies the spectral purity of each BBX carrier keyed up at a specific frequency, *per the current CDF file assignment*. All tests are performed using the external calibrated test set, controlled by the same command. All measurements are via the appropriate **TX OUT** (BTS/RFDS) connector.

The Pilot Gain is set to 541 for each antenna, and all channel elements from the MCCs are forward-link disabled. The BBX is keyed up, using both `bbxlvl` and bay level offsets, to generate a CDMA carrier (with pilot channel element only). BBX power output is set to obtain +40 dBm as measured at the **TX OUT** connector (on either the BTS or RFDS directional coupler).

NOTE

TX output power is set to +40 dBm by setting BTS power level to +33.5 dBm to compensate for 6.5 dB increase from pilot gain set to 541.

The calibrated communications test set measures and returns the attenuation level of all spurious and IM products in a 30 kHz resolution bandwidth. With respect to the mean power of the CDMA channel measured in a 1.23 MHz bandwidth in dB, verify that results meet system tolerances at the following test points:

- 1.7/1.9 GHz:
 - at least **-45 dB @ + 900 kHz** from center frequency
 - at least **-45 dB @ - 900 kHz** from center frequency
- 800 MHz:
 - at least **-45 dB @ + 750 kHz** from center frequency
 - at least **-45 dB @ - 750 kHz** from center frequency
 - at least **-60 dB @ - 1980 kHz** from center frequency
 - at least **-60 dB @ - 1980 kHz** from center frequency

The BBX then de-keys, and, if selected, the MCC is re-configured to assign the applicable redundant BBX to the current TX antenna path under test. The test is then repeated.

Figure 4-1: TX Mask Verification Spectrum Analyzer Display

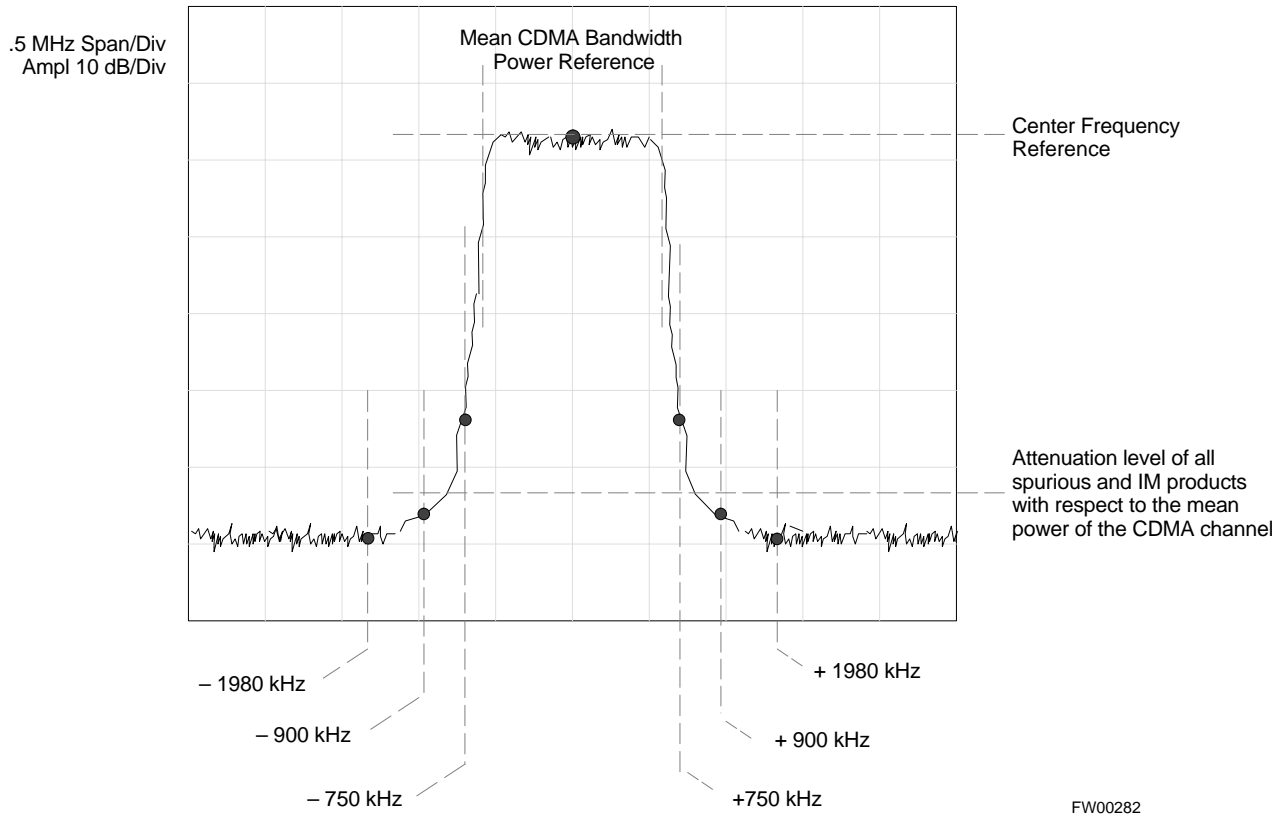

TX Waveform Quality (rho) Acceptance Test

Rho Test

This test verifies the transmitted Pilot channel element digital waveform quality of each BBX carrier keyed up at a specific frequency *per the current CDF file assignment*. All tests are performed using the external calibrated test set controlled by the same command. All measurements are via the appropriate **TX OUT** (BTS/RFDS) connector.

The Pilot Gain is set to 262 for each antenna, and all channel elements from the MCCs are forward link disabled. The BBX is keyed up using both `bbxlvl` and bay level offsets, to generate a CDMA carrier (with pilot channel element only, Walsh code 0). BBX power output is set to 40 dBm as measured at the **TX OUT** connector (on either the BTS or RFDS directional coupler).

The calibrated communications test set measures and returns the Pilot channel element digital waveform quality (rho) in dB, verifying that the result meets system tolerances:

- Waveform quality (rho) should be ≥ 0.912 (**-0.4 dB**).

The BBX then de-keys and, if selected, the MCC is re-configured to assign the applicable redundant BBX to the current TX antenna path under test. The test is then be repeated.



TX Pilot Time Offset Acceptance Test

Pilot Offset Acceptance Test

This test verifies the transmitted Pilot channel element Pilot Time Offset of each BBX carrier keyed up at a specific frequency *per the current CDF file assignment*. All tests are performed using the external calibrated test set controlled by the same command. All measurements are via the appropriate **TX OUT** (BTS/RFDS) connector.

The Pilot Gain is set to 262 for each antenna, and all TCH elements from the MCCs are forward link disabled. The BBX is keyed up, using both `bbxlvl` and bay level offsets, to generate a CDMA carrier (with pilot channel element only, Walsh code 0). BBX power output is set to 40 dBm as measured at the **TX OUT** connector (on either the BTS or RFDS directional coupler).

The calibrated communications test set measures and returns the Pilot Time Offset in μs , verifying results meet system tolerances:

- Pilot Time Offset should be within $\leq 3 \mu\text{s}$ of the target PT Offset (0 μs).

The BBX then de-keys, and if selected, the MCC is re-configured to assign the applicable redundant BBX to the current TX antenna path under test. The test is then repeated.

TX Code Domain Power/Noise Floor Acceptance Test

Code Domain Power Test

This test verifies the Code Domain Power/Noise of each BBX carrier keyed up at a specific frequency *per the current CDF file assignment*. All tests are performed using the external calibrated test set controlled by the same command. All measurements are via the appropriate **TX OUT** (BTS/RFDS) connector.

For each sector/antenna under test, the Pilot Gain is set to 262. All MCC channel elements under test are configured to generate Orthogonal Channel Noise Source (OCNS) on different odd Walsh codes and to be assigned a full-rate gain of 81. The maximum number of MCC/CEs to be tested at any one time is 32 (32 odd Walsh codes). If more than 32 CEs exist, then multiple sets of measurements are made; so all channel elements are verified on all sectors.

BBX power output is set to 40 dBm as measured at the **TX OUT** connector (on either the BTS or RFDS directional coupler).

You verify the code domain power levels, which have been set for all ODD numbered Walsh channels, using the OCNS command. This is done by verifying that Pilot Power (dBm) minus OCNS Power (dBm) is equal to **10.2 ± 2 dB** and that the noise floor of all “OFF” Walsh channels measures **≤ -27 dB** (with respect to total CDMA channel power).

The BBX then de-keys and, if selected, the MCC is re-configured to assign the applicable redundant BBX to the current TX antenna path under test. The test is then repeated. Upon completion of the test, OCNS is disabled on the specified MCC/CE.

TX Code Domain Power/Noise Floor Acceptance Test – continued

Figure 4-2: Code Domain Power and Noise Floor Levels

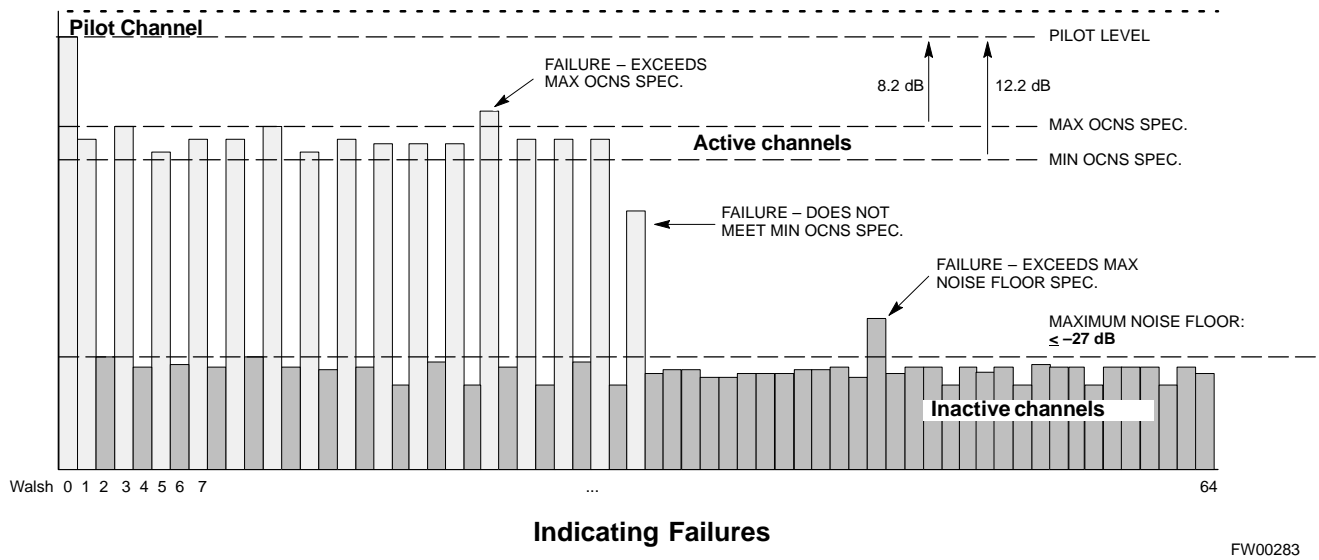
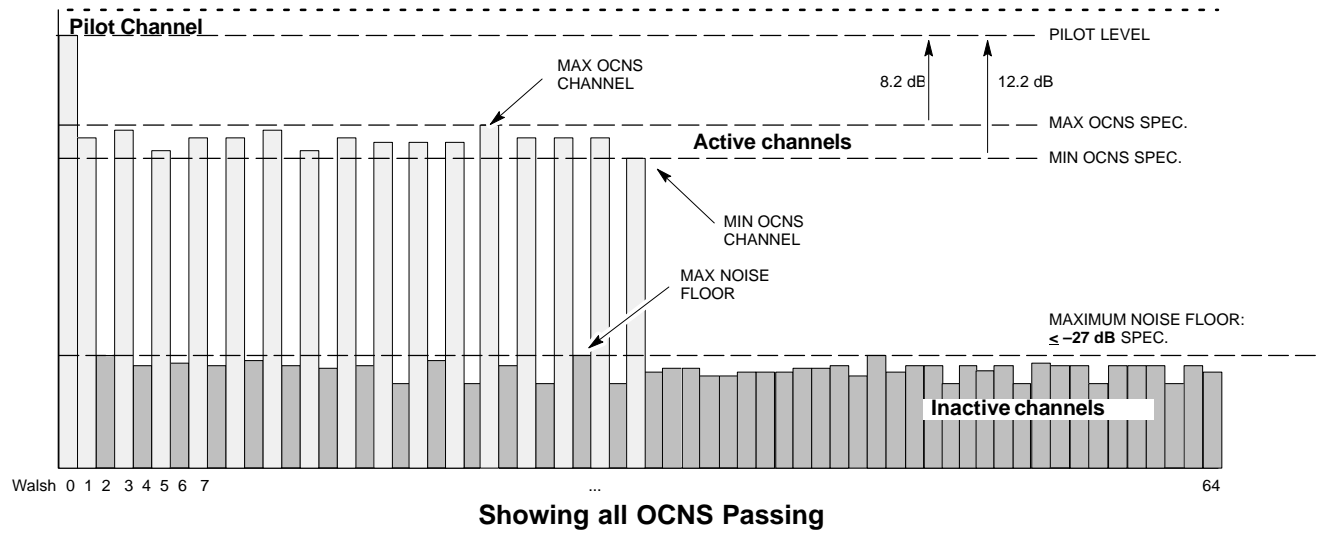

FW00283

RX Frame Error Rate (FER) Acceptance Test

FER Test

This test verifies the BTS FER on *all* traffic channel elements currently configured on *all* equipped MCCs (full rate at 1% FER) at an RF input level of -119 dBm [or -116 dBm if using Tower Top Amplifier (TMPC)]. All tests are performed using the external calibrated test set as the signal source controlled by the same command. All measurements are via the LMF.

The Pilot Gain is set to 262 for each TX antenna, and all channel elements from the MCCs are forward-link disabled. The BBX is keyed up, using only bbxlvl level offsets, to generate a CDMA carrier (with pilot channel element only). BBX power output is set to -20 dBm as measured at the **TX OUT** connector (on either the BTS or RFDS directional coupler). The BBX must be keyed to enable the RX receive circuitry.

The LMF prompts the MCC/CE under test to measure all zero longcode and provide the FER report on the selected active MCC on the reverse link for both the main and diversity RX antenna paths, verifying that results meet the following specification:

- FER returned less than **1%** and total frames measured is **1500**

All MCC/CEs selected are tested on the specified RX antenna path. The BBX then de-keys and, if selected, the MCC is re-configured to assign the applicable redundant BBX to the current RX antenna paths under test. The test is then repeated.

Generate an ATP Report

Background

Each time an ATP test is run, an ATP report is updated to include the results of the most recent ATP tests if the **Save Results** button is used to close the status report window. The ATP report *is not* updated if the status reports window is closed using the **Dismiss** button.

ATP Report

Each time an ATP test is run, a separate report is created for each BTS and includes the following for each test:

- Test name
- BBX number
- Channel number
- Carrier number
- Sector number
- Upper test limit
- Lower test limit
- Test result
- PASS or FAIL
- Description information (if applicable)
- Time stamp
- Details/Warning information (if applicable)

The report can be printed if the LMF computer is connected to a printer. Follow the procedure in the Table 4-2 to view and/or print the ATP report for a BTS.

Table 4-2: Generating an ATP Report

✓	Step	Action
	1	Click on the Login tab (if not in the forefront).
	2	Select the desired BTS from the available Base Station pick list.
	3	Click on the Report button.
	4	Click on a column heading to sort the report.
	5	<ul style="list-style-type: none">– If not desiring a printable file copy, click on the Dismiss button.– If requiring a printable file copy, select the desired file type in the picklist and click on the Save button.

Chapter 5: Prepare to Leave the Site

Table of Contents

Prepare to Leave the Site	5-1
External Test Equipment Removal	5-1
Reset All Devices	5-2
BTS Site Span Configuration Verification	5-3
Set BTS Site Span Configuration	5-4
Updating CBSC LMF Files	5-6
LMF Removal	5-6
Re-connect BTS T1 Spans and Integrated Frame Modem	5-8
Re-establish OMC-R Control/ Verifying T1/E1	5-8

Prepare to Leave the Site

External Test Equipment Removal

Perform the procedure in Table 5-1 to disconnect the test equipment and configure the BTS for active service.

Step	Action
1	Disconnect all external test equipment from all TX and RX connectors on the top of the frame.
2	Reconnect and visually inspect all TX and RX antenna feed lines at the top of the frame.



CAUTION

Verify that all sector antenna feed lines are connected to the correct ports on the frame. Crossed antenna cables will cause system degradation of call processing.

NOTE

Each module or device can be in any state prior to downloading. Each module or device will be in an OOS_RAM state after downloading has completed.

- For all LMF commands, information in *italics* represents valid ranges for that command field.
- Only those fields requiring an input will be specified. Default values for other fields will be assumed.
- For more complete command examples (including system response details), refer to the *CDMA LMF User Guide*.

Reset All Devices

Reset all devices by cycling power before leaving the site. The configuration data and code loads could be different from data and code on the LMF. By resetting all devices, the CBSC can load the proper data and code when the span is active again.

Follow the procedure in Table 5-2 *as required* to bring all processor modules from the OOS to INS mode.



IMPORTANT

Have the CBSC/MM bring up the site and enable all devices at the BTS.

Table 5-2: Enabling Devices

✓	Step	Action
	1	On the LMF, select the device(s) you wish to enable. NOTE The MGLI and CSM must be INS before an MCC can be put INS.
	2	Click on Device from the menu bar.
	3	Click on Enable from the Device menu. A status report window is displayed.
		NOTE If a BBX2 is selected, a Transceiver Parameters window is displayed to collect keying information. Do not enable the BBX2.
	4	Click OK to close the Transceiver Parameters window. A status report window displays the status of the device.
	5	Click OK to close the status report window. The selected devices that successfully change to INS change color to green.

5

Re-connect BTS T1 Spans and Integrated Frame Modem

Before leaving the site, connect any T1 span TELCO connectors that were removed to allow the LMF to control the BTS. Refer to Table 5-3 and Figure 5-1 as required.

Table 5-3: T1/E1 Span/IFM Connections	
Step	Action
1	Connect the 50-pin TELCO cables to the BTS span I/O board 50-pin TELCO connectors.
2	If used, connect the dial-up modem RS-232 serial cable to the Site I/O board RS-232 9-pin sub D connector. * IMPORTANT Verify that you connect both SPAN cables (if removed previously), and the Integrated Frame Modem (IFM) “TELCO” connector.

Figure 5-1: Site and Span I/O Boards T1 Span Connections

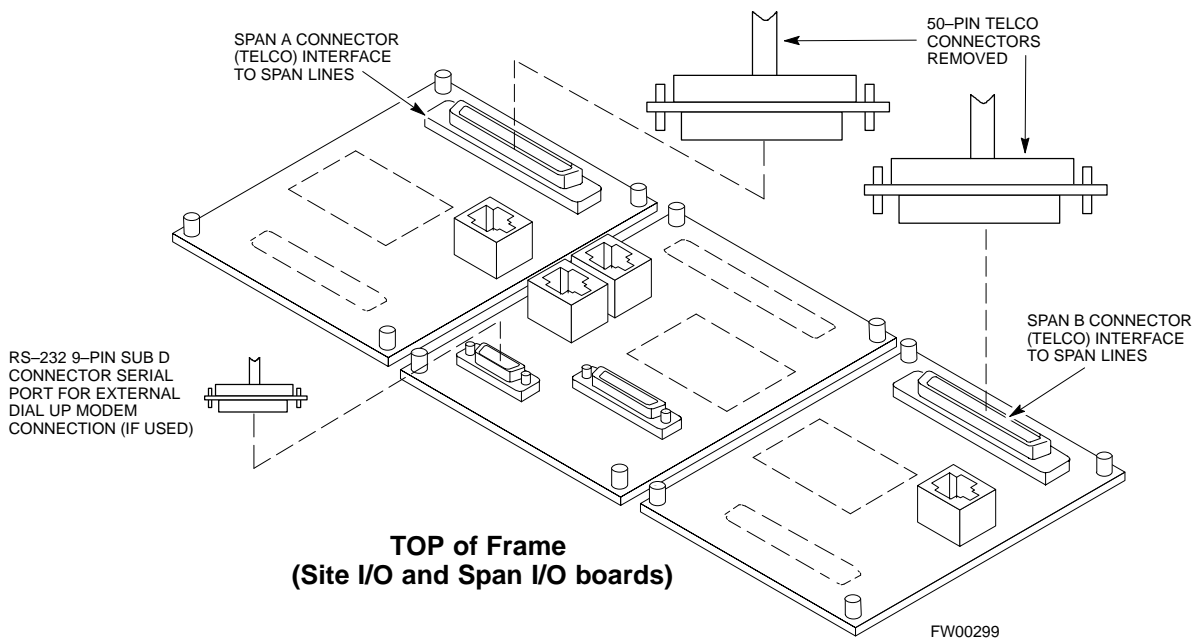

BTS Site Span Configuration Verification

Perform the procedure in Table 5-4 to verify the current Span Framing Format and Line Build Out (LBO) parameters. *ALL* MGLI2/SGLI2 boards in all C-CCP shelves that terminate a T1/E1 span should be verified.

Table 5-4: BTS Span Parameter Configuration

Step	Action
1	Connect a serial cable from the LMF COM1 port (via null modem board) to the front panel of the MGLI2 MMI port (see Figure 5-2).
2	<p>Start an MMI communication session with CSM-1 by using the Windows desktop shortcut icon (see Table 3-5 on page 3-11).</p> <p>NOTE The LMF program must not be running when a Hyperterminal session is started if COM1 is being used for the MMI session.</p>
3	<p>Enter the following MMI command to display the current MGLI2/SGLI2 framing format and line code configuration (in bold type):</p> <p style="padding-left: 40px;">span view <cr></p> <p>Observe a display similar to the options shown below:</p> <pre>COMMAND ACCEPTED: span view The parameter in NVM is set to T1_2. The frame format in flash is set to use T1_2. Equalization: Span A - Default (0-131 feet for T1/J1, 120 Ohm for E1) Span B - Default (0-131 feet for T1/J1, 120 Ohm for E1) Span C - Default (0-131 feet for T1/J1, 120 Ohm for E1) Span D - Default (0-131 feet for T1/J1, 120 Ohm for E1) Span E - Default (0-131 feet for T1/J1, 120 Ohm for E1) Span F - Default (0-131 feet for T1/J1, 120 Ohm for E1) Linkspeed: Default (56K for T1 D4 AMI, 64K otherwise) Currently, the link is running at the default rate The actual rate is 0</pre> <p>NOTE Defaults for span equalization are 0-131 feet for T1/J1 spans and 120 Ohm for E1. Default linkspeed is 56K for T1 D4 AMI spans and 64K for all other types. There is no need to change from defaults unless the OMC-R/CBSC span configuration requires it. If the current MGLI2/SGLI2 framing format and line code configuration does not display the correct choice, proceed to Table 5-5.</p>

5

Table 5-4: BTS Span Parameter Configuration

Step	Action
4	Repeat steps 1 through 3 for all remaining GLIs.
5	Exit the GLI MMI session and HyperTerminal connection by selecting File from the connection window menu bar, and then Exit from the dropdown menu.

Figure 5-2: MGLI2/SGLI2 MMI Port Connection

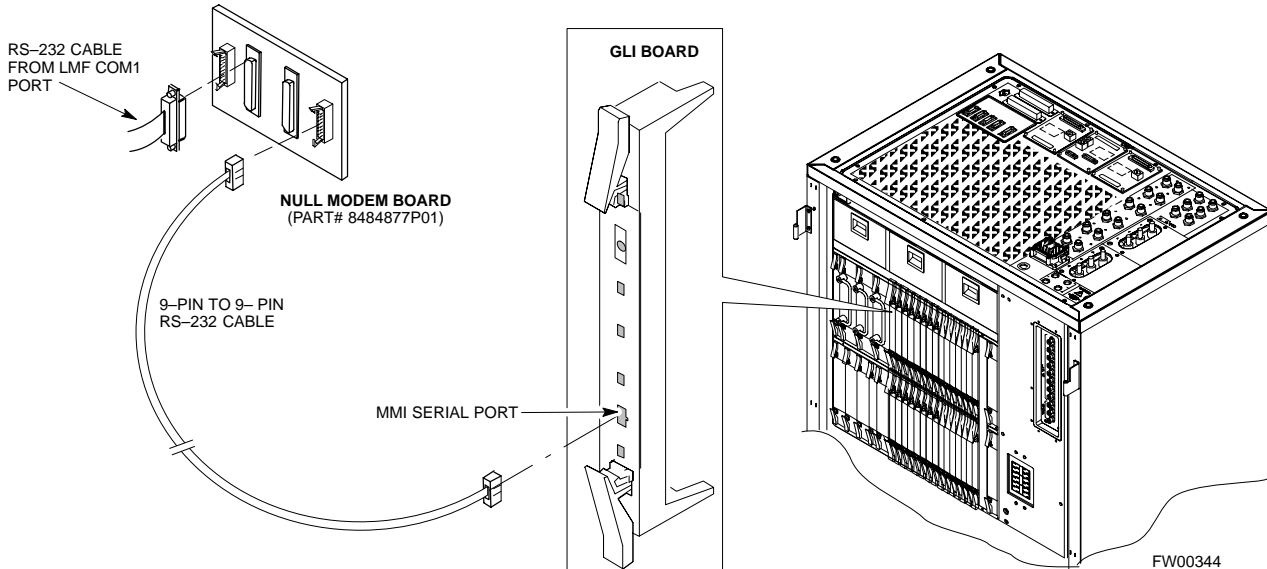

Set BTS Site Span Configuration

Perform the procedure in Table 5-5 to configure the Span Framing Format and Line Build Out (LBO) parameters. *ALL* MGLI2/SGLI2 boards in all C-CCP shelves that terminate a T1/E1 span must be configured.



IMPORTANT

Perform the following procedure *ONLY* if span configurations loaded in the MGLI2/GLI2s do not match those in the OMCR/CBSC data base, *AND ONLY* when the exact configuration data is available. Loading incorrect span configuration data will render the site inoperable.

Table 5-5: Set BTS Span Parameter Configuration

Step	Action
1	If not already done, connect a serial cable from the LMF COM1 port (via null modem board) to the front panel of the MGLI2 MMI port (see Figure 5-2).
2	<p>Start an MMI communication session with CSM-1 by using the Windows desktop shortcut icon (see Table 3-5 on page 3-11).</p> <p>NOTE The LMF program must not be running when a Hyperterminal session is started if COM1 is being used for the MMI session.</p>
3	<p><i>If required only</i>, enter the following MMI command for each span line to set the BTS span parameters to match that of the physical spans <i>a–f</i> run to the site:</p> <p>span_config <option#1> <option#2> <option#3> <option#4> <option#5></p> <p><i>option#1</i> = the span to change (a–f)</p> <p><i>option#2</i> = the span type (0–8):</p> <ul style="list-style-type: none"> 0 – E1_1 (HDB3, CCS, CRC-4) 1 – E1_2 (HDB3, CCS) 2 – E1_3 (HDB3, CAS, CRC-4, TS16) 3 – E1_4 (HDB3, CAS, TS16) 4 – T1_1 (AMI, DS1 AT&T D4, without ZCS, 3 to 1 packing, Group 0 unusable) 5 – T1_2 (B8ZS, DS1 AT&T ESF, 4 to 1 packing, 64K link) 6 – J1_1 (B8ZS, J1 AT&T ESF, Japan CRC6, 4 to 1 packing) 7 – J1_2 (B8ZS, J1 AT&T ESF, US CRC6, 4 to 1 packing) 8 – T1_3 (AMI, DS1 AT&T D4, with ZCS, 3 to 1 packing, Group 0 unusable) <p><i>option#3</i> = the link speed (56 or 64) Kbps</p> <p><i>option#4</i> = the span equalization (0–7):</p> <ul style="list-style-type: none"> 0 – T1_6 (T1,J1:long haul) 1 – T1_4 (T1,J1:393–524 feet) 2 – T1_4 (T1,J1:131–262 feet) 3 – E1_75 (E1:75 Ohm) 4 – T1_4 (T1,J1:0–131 feet) 5 – T1_4 (T1,J1:524–655 feet) 6 – T1_4 (T1,J1:262–393 feet) 7 – E1_120 (E1:120 Ohm) <p><i>option#5</i> = the slot that has LAPD channel (0–31)</p> <p><i>Example for setting span configuration to E1_2, 64 Kbps, E1_120–Ohm, LAPD channel 1:</i></p> <pre>span_config a 1 64 7 1 . . span_config f 1 64 7 1</pre> <p><i>Example for setting span configuration to T1_2, 64 Kbps, T1_4 (0–131 feet), LAPD channel 0:</i></p> <pre>span_config a 5 64 4 0 . . span_config f 5 64 4 0</pre>

... continued on next page

5

Table 5-5: Set BTS Span Parameter Configuration

Step	Action
	<p>* IMPORTANT</p> <p>Make sure that spans <i>a – f</i> are set to the same span type and link speed. The equalization may be different for each individual span.</p> <p>After executing the span_config command, the affected MGLI2/SGLI2 board MUST be reset and re-loaded for changes to take effect.</p> <p>Although defaults are shown, always consult site specific documentation for span type and rate used at the site.</p>
4	Press the RESET button on the GLI2 for changes to take effect.
5	This completes the site specific BTS Span setup for this GLI. Move the MMI cable to the next SGLI2 and repeat steps 1 and 4 for <i>ALL</i> MGLI2/SGLI2 boards.
6	Terminate the Hyperterm session and disconnect the LMF from the MGLI/SGLI.

Updating CBSC LMF Files

Updated calibration (CAL) file information must be moved from the LMF Windows environment back to the CBSC, which resides in a Unix environment. The procedures that follow detail how to move files from one environment to the other.

Backup CAL Data to a Diskette

The BLO calibration files should be backed up to a diskette (per BTS). Follow the procedure in Table 5-6 to copy CAL files from a CDMA LMF computer to a diskette.

Table 5-6: Backup CAL Data to a Diskette

Step	Action
1	<p>Insert a diskette into the LMF A drive.</p> <p>NOTE</p> <p>If your diskette has not been formatted, format it using Windows. The diskette must be DOS formatted before copying any files. Consult your Windows/DOS documentation or on-line help on how to format diskettes.</p>
2	Click on the Start button and launch the Windows Explorer program from the Programs menu.
3	Click on your C: drive.
4	Double Click on the wlmf folder.
5	Double Click on the CDMA folder.
6	Click on the bts-# folder for the calibration file you want to copy.
7	Drag the BTS-#.cal file to the 3-1/2 floppy (A:) icon on the top left of the screen and release the mouse button.
8	Repeat steps 6 and 7 until you have copied each file desired.
9	Close the Windows Explorer program by selecting Close from the File menu option.

LMF Removal



CAUTION

DO NOT power down the LMF without performing the procedure indicated below. Corrupted/lost data files may result, and in some cases, the LMF may lock up.

Follow the procedure in Table 5-7 to terminate the LMF session and remove the terminal.

Table 5-7: LMF Termination and Removal

✓	Step	Action
	1	From the CDMA window select File>Exit .
	2	From the Windows Task Bar click Start>Shutdown . Click Yes when the Shut Down Windows message appears.
	3	Disconnect the LMF terminal Ethernet connector from the BTS cabinet.
	4	Disconnect the LMF serial port, the RS-232 to GPIB interface box, and the GPIB cables as required for equipment transport.

Copying CAL Files from Diskette to the CBSC

Follow the procedure in Table 5-8 to copy CAL files from a diskette to the CBSC.

Table 5-8: Procedures to Copy CAL Files from Diskette to the CBSC

✓	Step	Action
	1	Login to the CBSC on the workstation using your account name and password. NOTE Enter the information that appears in bold text .
	2	Place your diskette containing CAL file(s) in the CBSC workstation diskette drive.
	3	Type eject -q and press the <Enter> key.
	4	Type mount and press the <Enter> key. Verify that <code>floppy/no_name</code> is displayed.
		NOTE If the eject command has been previously entered, <code>floppy/no_name</code> will be appended with a <u>number</u> . Use the explicit <code>floppy/no_name</code> reference displayed.
	5	Enter cd /floppy/no_name and press the <Enter> key.
	6	Enter ls -lia and press the <Enter> key. Verify that the bts-#.cal file is on the diskette.
	7	Enter cd and press the <Enter> key.

... continued on next page

Table 5-8: Procedures to Copy CAL Files from Diskette to the CBSC

✓	Step	Action
	8	Enter pwd and press the <Enter> key. Verify that you are in your home directory (/home/<name>).
	9	Enter dos2unix /floppy/no_name/bts-#.cal bts-#.cal and press the <Enter> key (where # is the BTS number).
	10	Enter ls -l *.cal and press the <Enter> key. Verify that the CAL file was successfully copied.
	11	Type eject and press the <Enter> key.
	12	Remove the diskette from the workstation.

**Re-establish OMC-R Control/
Verifying T1/E1**



IMPORTANT

After all activities at the site have been completed, and after disconnecting the LMF, place a phone call to the OMC-R and request the BTS be placed under control of the OMC-R.

Chapter 6: Basic Troubleshooting

Table of Contents

Basic Troubleshooting Overview	6-1
Overview	6-1
Troubleshooting: Installation	6-2
Cannot Log into Cell-Site	6-2
Cannot Communicate to Power Meter	6-2
Cannot Communicate to Communications Analyzer	6-3
Troubleshooting: Download	6-4
Cannot Download CODE to Any Device (card)	6-4
Cannot Download DATA to Any Device (Card)	6-4
Cannot ENABLE Device	6-5
Miscellaneous Errors	6-5
Troubleshooting: Calibration	6-6
Bay Level Offset Calibration Failure	6-6
Cannot Load BLO	6-7
Calibration Audit Failure	6-7
Troubleshooting: Transmit ATP	6-8
Cannot Perform TX Mask Measurement	6-8
Cannot Perform Rho or Pilot Time Offset Measurement	6-8
Cannot Perform Code Domain Power and Noise Floor Measurement .	6-9
Cannot Perform Carrier Measurement	6-9
Troubleshooting: Receive ATP	6-10
Multi-FER Test Failure	6-10
Troubleshooting: CSM Checklist	6-11
Problem Description	6-11
Intermittent 19.6608 MHz Reference Clock/GPS Receiver Operation .	6-11
No GPS Reference Source	6-11
Checksum Failure	6-11
GPS Bad RX Message Type	6-11
CSM Reference Source Configuration Error	6-11
Takes Too Long for CSM to Come INS	6-12
C-CCP Backplane Troubleshooting	6-13
Introduction	6-13
Connector Functionality	6-13
C-CCP Backplane Troubleshooting Procedure	6-14
Digital Control Problems	6-15

Table of Contents – continued

DC Power Problems	6-18
TX and RX Signal Routing Problems	6-19
Module Front Panel LED Indicators and Connectors	6-20
Module Status Indicators	6-20
LED Status Combinations for All Modules (except GLI2, CSM, BBX2, MCC24, MCC8E)	6-20
DC/DC Converter LED Status Combinations	6-20
CSM LED Status Combinations	6-21
GLI2 LED Status Combinations	6-23
GLI2 Pushbuttons and Connectors	6-24
BBX2 LED Status Combinations	6-25
MCC24/8E LED Status Combinations	6-25
LPA Shelf LED Status Combinations	6-26
Basic Troubleshooting – Span Control Link	6-27
Span Problems (No Control Link)	6-27

Basic Troubleshooting Overview

Overview

The information in this section addresses some of the scenarios likely to be encountered by Cellular Field Engineering (CFE) team members. This troubleshooting guide was created as an interim reference document for use in the field. It provides basic “what to do if” basic troubleshooting suggestions when the BTS equipment does not perform per the procedure documented in the manual.

Comments are consolidated from inputs provided by CFEs in the field and information gained from experience in Motorola labs and classrooms.

Troubleshooting: Installation

Cannot Log into Cell-Site

Follow the procedure in Table 6-1 to troubleshoot a login failure.

Table 6-1: Login Failure Troubleshooting Procedures		
✓	Step	Action
	1	If MGLI2 LED is solid RED, it implies a hardware failure. Reset MGLI2 by re-seating it. If this persists, install a known good MGLI2 card in MGLI2 slot and retry. A Red LED may also indicate no Ethernet termination at top of frame.
	2	Verify that T1 is disconnected (see Table 3-1 on page 3-4). If T1 is still connected, verify the CBSC has disabled the BTS.
	3	Try <i>pinging</i> the MGLI2 (see Table 3-6 on page 3-15).
	4	Verify the LMF is connected to the Primary LMF port (LAN A) in the front of the BTS (see Table 3-2 on page 3-5).
	5	Verify the LMF was configured properly (see Preparing the LMF section starting on page 3-6).
	6	Verify the BTS-LMF cable is RG-58 [flexible black cable of less than 76 cm (2.5 feet) length].
	7	Verify the Ethernet ports are terminated properly (see Figure 3-4 on page 3-14).
	8	Verify a T-adaptor is <u>not</u> used on the LMF side port if connected to the BTS front LMF primary port.
	9	Try connecting to the I/O panel (top of frame). Use BNC T-adapters at the LMF port for this connection.
	10	Re-boot the LMF and retry.
	11	Re-seat the MGLI2 and retry.
	12	Verify IP addresses are configured properly.

Cannot Communicate to Power Meter

Follow the procedure in Table 6-2 to troubleshoot a power meter communication failure.

Table 6-2: Troubleshooting a Power Meter Communication Failure		
✓	Step	Action
	1	Verify the Power Meter is connected to the LMF with a GPIB adapter.
	2	Verify the cable setup as specified in Chapter 3.
	3	Verify the GPIB address of the Power Meter is set to 13.
	4	Verify the GPIB adapter DIP switch settings are correct. Refer to the Test Equipment setup section for details.

. . . continued on next page

Table 6-2: Troubleshooting a Power Meter Communication Failure

✔	Step	Action
	5	Verify the GPIB adapter is not locked up. Under normal conditions, only two green LEDs must be 'ON' (Power and Ready). If any other LED is continuously 'ON', then power-cycle the GPIB Box and retry.
	6	Verify that the Com1 port is not used by another application.
	7	Verify that the communications analyzer is in Talk&Listen, not Control mode.

Cannot Communicate to Communications Analyzer

Follow the procedure in Table 6-3 to troubleshoot a communications analyzer communication failure.

Table 6-3: Troubleshooting a Communications Analyzer Communication Failure

✔	Step	Action
	1	Verify the analyzer is connected to the LMF with GPIB adapter.
	2	Verify the cable setup.
	3	Verify the GPIB address is set to 18.
	4	Verify the GPIB adapter DIP switch settings are correct. Refer to the Test Equipment setup section starting on page 3–34 for details.
	5	Verify the GPIB adapter is not locked up. Under normal conditions, only 2 green LEDs must be 'ON' (Power and Ready). If any other LED is continuously 'ON', then power-cycle the GPIB Box and retry.
	6	Verify that the Com1 port is not used by another application.
	7	If a Hyperterm window is open for MMI, close it.

Troubleshooting: Download

Cannot Download CODE to Any Device (card)

Follow the procedure in Table 6-4 to troubleshoot a code download failure.

Table 6-4: Troubleshooting Code Download Failure

✓	Step	Action
	1	Verify T1 is disconnected from the BTS.
	2	Verify the LMF can communicate with the BTS device using the Status function.
	3	Communication to the MGLI2 must first be established before trying to talk to any other BTS device. The MGLI2 must be INS_ACT state (green).
	4	Verify the card is physically present in the cage and powered-up.
	5	If the card LED is solid RED, it implies hardware failure. Reset the card by re-seating it. If the LED remains solid red, replace with a card from another slot & retry. NOTE The card can only be replaced by a card of the same type.
	6	Re-seat the card and try again.
	7	If BBX reports a failure message and is OOS_RAM, the code load was OK.
	8	If the download portion completes and the reset portion fails, reset the device by selecting the device and Reset .

Cannot Download DATA to Any Device (Card)

Perform the procedure in Table 6-5 to troubleshoot a data download failure.

Table 6-5: Troubleshooting Data Download Failure

✓	Step	Action
	1	Re-seat the card and repeat code and data load procedure.

Cannot ENABLE Device

Before a device can be enabled (placed in-service), it must be in the OOS_RAM state (yellow) with data downloaded to the device. The color of the device changes to green once it is enabled.

The three states that devices can be changed to are as follows:

- Enabled (green, INS)
- Disabled (yellow, OOS_RAM)
- Reset (blue, OOS_ROM)

Follow the procedure in Table 6-6 to troubleshoot a device enable failure.

Table 6-6: Troubleshooting Device Enable (INS) Failure

✔	Step	Action
	1	Re-seat the card and repeat the code and data load procedure.
	2	If the CSM cannot be enabled, verify the CDF file has correct latitude and longitude data for cell site location and GPS sync.
	3	Ensure the primary CSM is in INS_ACT state. NOTE MCCs will not go INS without the CSM being INS.
	4	Verify the 19.6608 MHz CSM clock; MCCs will not go INS otherwise.
	5	The BBX should not be enabled for ATP tests.
	6	If MCCs give “invalid or no system time”, verify the CSM is operable.

Miscellaneous Errors

Perform the procedure in Table 6-7 to troubleshoot miscellaneous failures.

Table 6-7: Miscellaneous Failures

✔	Step	Action
	1	If LPAs continue to give alarms, even after cycling power at the circuit breakers, then connect an MMI cable to the LPA and set up a Hyperterminal connection (see Table 3-5 on page 3-11).
	2	Enter ALARMS in the Hyperterminal window. The resulting LMF display may provide an indication of the problem. (Call Field Support for further assistance.)

Troubleshooting: Calibration

Bay Level Offset Calibration Failure

Perform the procedure in Table 6-8 to troubleshoot a BLO calibration failure.

Table 6-8: Troubleshooting BLO Calibration Failure

✓	Step	Action
	1	Verify the Power Meter is configured correctly (see the test equipment setup section in Chapter 3) and connection is made to the proper TX port.
	2	Verify the parameters in the bts-#.cdf file are set correctly for the following bands: For 1900 MHz: Bandclass=1; Freq_Band=16; SSType=16 For 800 MHz: Bandclass=0; Freq_Band=8; SSType=8 For 1700 MHz: Bandclass=4; Freq_Band=128; SSType=16
	3	Verify that no LPA in the sector is in alarm state (flashing red LED). Reset the LPA by pulling the circuit breaker and, after 5 seconds, pushing back in.
	4	Re-calibrate the Power Meter and verify it is calibrated correctly with cal factors from the sensor head.
	5	Verify the GPIB adapter is not locked up. Under normal conditions, only two green LEDs must be 'ON' (Power and Ready). If any other LED is continuously 'ON', power-cycle (turn power off and on) the GPIB Box and retry.
	6	Verify the sensor head is functioning properly by checking it with the 1 mW (0 dBm) Power Ref signal.
	7	If communication between the LMF and Power Meter is operational, the Meter display will show "RES".

Troubleshooting: Calibration – continued

Cannot Load BLO

For Load BLO failures see Table 6-7.

Calibration Audit Failure

Follow the procedure in Table 6-9 to troubleshoot a calibration audit failure.

Table 6-9: Troubleshooting Calibration Audit Failure		
✓	Step	Action
	1	Verify the Power Meter is configured correctly (refer to the test equipment setup section of Chapter 3).
	2	Re-calibrate the Power Meter and verify it is calibrated correctly with cal factors from the sensor head.
	3	Verify that no LPA is in alarm state (rapidly flashing red LED). Reset the LPA by pulling the circuit breaker and, after 5 seconds, pushing back in.
	4	Verify that no sensor head is functioning properly by checking it with the 1 mW (0 dBm) Power Ref signal.
	5	After calibration, the BLO data must be re-loaded to the BBXs before auditing. Click on the BBX(s) and select Device>Download BLO . Re-try the audit.
	6	Verify the GPIB adapter is not locked up. Under normal conditions, only two green LEDs must be “ON” (Power and Ready). If any other LED is continuously “ON”, power-cycle (turn power off and on) the GPIB Box and retry.

Troubleshooting: Transmit ATP

Cannot Perform TX Mask Measurement

Follow the procedure in Table 6-10 to troubleshoot a TX mask measurement failure.

✓	Step	Action
	1	Verify that TX audit passes for the BBX(s).
	2	If performing manual measurement, verify analyzer setup.
	3	Verify that no LPA in the sector is in alarm state (flashing red LED). Re-set the LPA by pulling the circuit breaker and, after 5 seconds, pushing it back in.

Cannot Perform Rho or Pilot Time Offset Measurement

Follow the procedure in Table 6-11 to troubleshoot a rho or pilot time offset measurement failure.

✓	Step	Action
	1	Verify presence of RF signal by switching to spectrum analyzer screen.
	2	Verify PN offsets displayed on the analyzer is the same as the PN offset in the CDF file.
	3	Re-load BBX data and repeat the test.
	4	If performing manual measurement, verify analyzer setup.
	5	Verify that no LPA in the sector is in alarm state (flashing red LED). Reset the LPA by pulling the circuit breaker and, after 5 seconds, pushing back in.
	6	If Rho value is unstable and varies considerably (e.g. .95,.92,.93), this may indicate that the GPS is still phasing (i.e., trying to reach and maintain 0 freq. error). Go to the freq. bar in the upper right corner of the Rho meter and select H z. Press <Shift-avg> and enter 10 , to obtain an average Rho value. This is an indication the GPS has not stabilized before going <i>INS</i> and may need to be re-initialized.

Troubleshooting – Transmit ATP – continued

Cannot Perform Code Domain Power and Noise Floor Measurement

Perform the procedure in Table 6-12 to troubleshoot a code domain and noise floor measurement failure.

Table 6-12: Troubleshooting Code Domain Power and Noise Floor Measurement Failure		
✓	Step	Action
	1	Verify presence of RF signal by switching to spectrum analyzer screen.
	2	Verify PN offset displayed on analyzer is same as PN offset being used in the CDF file.
	3	Disable and re-enable MCC (one or more MCCs based on extent of failure).

Cannot Perform Carrier Measurement

Perform the procedure in Table 6-13 to troubleshoot a carrier measurement failure.

Table 6-13: Troubleshooting Carrier Measurement Failure		
✓	Step	Action
	1	Perform the test manually, using the spread CDMA signal.
	2	Verify High Stability 10 MHz Rubidium Standard is warmed up (60 minutes) and properly connected to test set-up.

Troubleshooting: Receive ATP

Multi-FER Test Failure

Perform the procedure in Table 6-14 to troubleshoot a Multi-FER failure.

Table 6-14: Troubleshooting Multi-FER Failure		
✓	Step	Action
	1	Verify the test equipment set up is correct for an FER test.
	2	Verify the test equipment is locked to 19.6608 and even second clocks. On the HP8921A test set, the yellow LED (REF UNLOCK) must be OFF.
	3	Verify the MCCs have been loaded with data and are INS-ACT.
	4	Disable and re-enable the MCC (one or more based on extent of failure).
	5	Disable, re-load code and data, and re-enable the MCC (one or more MCCs based on extent of failure).
	6	Verify the antenna connections to frame are correct based on the directions messages.

Troubleshooting: CSM Checklist

Problem Description

Many of the Clock Synchronization Manager (CSM) board failures may be resolved in the field before sending the boards to the factory for repair. This section describes known CSM problems identified in field returns, some of which are field-repairable. Check these problems before returning suspect CSM boards.

Intermittent 19.6608 MHz Reference Clock/GPS Receiver Operation

If having any problems with CSM board kit numbers, SGLN1145 or SGLN4132, check the suffix with the kit number. If the kit has version “AB”, then replace with version “BC” or higher, and return model “AB” to the repair center.

No GPS Reference Source

Check the CSM boards for proper hardware configuration. CSM kit SGLN1145, in Slot 1, has an on-board GPS receiver; while kit SGLN4132, in Slot 2, does not have a GPS receiver. Any incorrectly configured board *must* be returned to the repair center. *Do not attempt to change hardware configuration in the field.* Also, verify the GPS antenna is not damaged and is installed per recommended guidelines.

Checksum Failure

The CSM could have corrupted data in its firmware resulting in a non-executable code. The problem is usually caused by either electrical disturbance or interruption of data during a download. Attempt another download with no interruptions in the data transfer. Return the CSM board back to the repair center if the attempt to reload fails.

GPS Bad RX Message Type

This problem is believed to be caused by a later version of CSM software (3.5 or higher) being downloaded, via LMF, followed by an earlier version of CSM software (3.4 or lower), being downloaded from the CBSC. Download again with CSM software code 3.5 or higher. Return the CSM board back to the repair center if the attempt to reload fails.

CSM Reference Source Configuration Error

This problem is caused by incorrect reference source configuration performed in the field by software download. CSM kits SGLN1145 and SGLN4132 must have proper reference sources configured (as shown below) to function correctly.

CSM Kit No.	Hardware Configuration	CSM Slot No.	Reference Source Configuration	CDF Value
SGLN1145	With GPS Receiver	1	Primary = Local GPS Backup = Either LFR or HSO	0 2 or 18
SGLN4132	Without GPS Receiver	2	Primary = Remote GPS Backup = Either LFR or HSO	1 2 or 18

Takes Too Long for CSM to Come INS

This problem may be caused by a delay in GPS acquisition. Check the accuracy flag status and/or current position. Refer to the GSM system time/GPS and LFR/HSO verification section in Chapter 3. At least one satellite should be visible and tracked for the “surveyed” mode and four satellites should be visible and tracked for the “estimated” mode. Also, verify correct base site position data used in “surveyed” mode.

C-CCP Backplane Troubleshooting

Introduction

The C-CCP backplane is a multi-layer board that interconnects all the C-CCP modules. The complexity of this board lends itself to possible improper diagnoses when problems occur.

Connector Functionality

The following connector overview describes the major types of backplane connectors along with the functionality of each. This information allows the CFE to:

- Determine which connector(s) is associated with a specific problem type.
- Isolate problems to a specific cable or connector.

Primary “A” and Redundant “B” Inter Shelf Bus Connectors

The 40 pin Inter Shelf Bus (ISB) connectors provide an interface bus from the master GLI2 to all other GLI2s in the modem frame. Their basic function is to provide clock synchronization from the master GLI2 to all other GLI2s in the frame.

The ISB also provides the following functions:

- Span line grooming when a single span is used for multiple cages.
- MMI connection to/from the master GLI2 to cell site modem.
- Interface between GLI2s and the AMR (for reporting BTS alarms).

Span Line Connector

The span line input is an 8-pin RJ-45 connector that provides a primary and secondary (if used) span line interface to each GLI2 in the C-CCP shelf. The span line is used for MM/EMX switch control of the Master GLI2 and also all the BBX traffic.

Primary “A” and Redundant “B” Reference Distribution Module Input/Output

The Reference Distribution Module (RDM) connectors route the 3 MHz reference signals from the CSMs to the GLI2s and all BBXs in the backplane. The signals are used to phase lock loop all clock circuits on the GLI2s and BBX boards to produce precise clock and signal frequencies.

Power Input (Return A, B, and C connectors)

Provides a +27 volt or -48 volt input for use by the power supply modules.

. . . continued on next page

Power Supply Module Interface

Each power supply module has a series of three different connectors to provide the needed inputs/outputs to the C-CCP backplane. These include a VCC/Ground input connector, a Harting style multiple pin interface, and a +15 V/Analog Ground output connector. The C-CCP Power Modules convert +27 or -48 Volts to a regulated +15, +6.5, and +5.0 Volts to be used by the C-CCP shelf cards. In the -48 V BTS, the LPA power modules convert -48 Volts to a regulated +27 Volts.

GLI2 Connector

This connector consists of a Harting 4SU digital connector and a 6-conductor coaxial connector for RDM distribution. The connectors provide inputs/outputs for the GLI2s in the C-CCP backplane.

GLI2 Ethernet “A” and “B” Connections

These BNC connectors are located on the C-CCP backplane and routed to the GLI2 board. This interface provides all the control and data communications between the master GLI2 and the other GLI2, between gateways, and for the LMF on the LAN.

BBX Connector

Each BBX connector consists of a Harting 2SU/1SU digital connector and two 6-conductor coaxial connectors. These connectors provide DC, digital, and RF inputs/outputs for the BBXs in the C-CCP backplane.

CIO Connectors

- RX RF antenna path signal inputs are routed through RX Tri-Filters (on the I/O plate), and via coaxial cables to the two MPC modules – the six “A” (main) signals go to one MPC; the six “B” (diversity) to the other. The MPC outputs the low-noise-amplified signals via the C-CCP backplane to the CIO where the signals are split and sent to the appropriate BBX.
- A digital bus then routes the baseband signal through the BBX, to the backplane, then on to the MCC slots.
- Digital TX antenna path signals originate at the MCCs. Each output is routed from the MCC slot via the backplane appropriate BBX.
- TX RF path signal originates from the BBX, through the backplane to the CIO, through the CIO, and via multi-conductor coaxial cabling to the LPAs in the LPA shelf.

C-CCP Backplane Troubleshooting Procedure

Table 6-15 through Table 6-24 provide procedures for troubleshooting problems that appear to be related to a defective C-CCP backplane. The tables are broken down into possible problems and steps that should be taken in an attempt to find the root cause.

. . . continued on next page



IMPORTANT

Table 6-15 through Table 6-24 must be completed before replacing ANY C-CCP backplane.

Digital Control Problems

No GLI2 Control via LMF (all GLI2s)

Follow the procedure in Table 6-15 to troubleshoot a GLI2 control via LMF failure.

Table 6-15: No GLI2 Control via LMF (all GLI2s)

✓	Step	Action
	1	Check the ethernet for proper connection, damage, shorts, or opens.
	2	Verify the C-CCP backplane Shelf ID DIP switch is set correctly.
	3	Visually check the master GLI2 connector (both board and backplane) for damage.
	4	Replace the master GLI2 with a known good GLI2.

No GLI2 Control through Span Line Connection (All GLI2s)

Follow the procedures in Table 6-16 and Table 6-17 to troubleshoot GLI2 control failures.

Table 6-16: No GLI2 Control through Span Line Connection (Both GLI2s)

Step	Action
1	Verify the C-CCP backplane Shelf ID DIP switch is set correctly.
2	Verify that the BTS and GLI2s are correctly configured in the OMCR/CBSC data base.
3	Visually check the master GLI2 connector (both board and backplane) for damage.
4	Replace the master GLI2 with a known good GLI2.
5	Check the span line inputs from the top of the frame to the master GLI2 for proper connection and damage.
6	Check the span line configuration on the MGLI2 (see Table 5-4 on page 5-4).

Table 6-17: MGLI2 Control Good – No Control over Co-located GLI2

Step	Action
1	Verify that the BTS and GLI2s are correctly configured in the OMCR CBSC data base.
2	Check the ethernet for proper connection, damage, shorts, or opens.
3	Visually check all GLI2 connectors (both board and backplane) for damage.
4	Replace the remaining GLI2 with a known good GLI2.

No AMR Control (MGLI2 good)

Perform the procedure in Table 6-18 to troubleshoot an AMR control failure when the MGLI control is good.

Table 6-18: MGLI2 Control Good – No Control over AMR	
Step	Action
1	Visually check the master GLI2 connector (both board and backplane) for damage.
2	Replace the master GLI2 with a known good GLI2.
3	Replace the AMR with a known good AMR.

No BBX Control in the Shelf – (No Control over Co-located GLI2s)

Perform the procedure in Table 6-19 to troubleshoot a BBX control in the shelf failure.

Table 6-19: No BBX Control in the Shelf – No Control over Co-located GLI2s	
Step	Action
1	Visually check all GLI2 connectors (both board and backplane) for damage.
2	Replace the remaining GLI2 with a known good GLI2.
3	Visually check BBX connectors (both board and backplane) for damage.
4	Replace the BBX with a known good BBX.

No (or Missing) Span Line Traffic

Perform the procedure in Table 6-20 to troubleshoot a span line traffic failure.

Table 6-20: MGLI2 Control Good – No (or Missing) Span Line Traffic	
Step	Action
1	Visually check all GLI2 connectors (both board and backplane) for damage.
2	Replace the remaining GLI2 with a known good GLI2.
3	Visually check all span line distribution (both connectors and cables) for damage.
4	If the problem seems to be limited to one BBX, replace the MGLI2 with a known good MGLI2.
5	Perform the BTS Span Parameter Configuration (see Table 5-4 on page 5-4).
6	Ensure that ISB cabling is correct.

6

No (or Missing) MCC Channel Elements

Perform the procedure in Table 6-21 to troubleshoot a channel elements failure.

Table 6-21: No MCC Channel Elements	
Step	Action
1	Verify CEs on a co-located MCC (MCC24 TYPE=2)
2	If the problem seems to be limited to one MCC, replace the MCC with a known good MCC. – Check connectors (both board and backplane) for damage.
3	If no CEs on any MCC: – Verify clock reference to CIO.
4	Check the CDF for MCCTYPE=2 (MCC24) or MCCTYPE=0 (MCC8).

DC Power Problems

Perform the procedure in Table 6-22 to troubleshoot a DC input voltage to power supply module failure.



WARNING

Potentially lethal voltage and current levels are routed to the BTS equipment. This test must be carried out with a second person present, acting in a safety role. Remove all rings, jewelry, and wrist watches prior to beginning this test.

No DC Input Voltage to Power Supply Module

Table 6-22: No DC Input Voltage to Power Supply Module

Step	Action
1	Verify DC power is applied to the BTS frame.
2	Verify there are no breakers tripped. * IMPORTANT If a breaker has tripped, remove all modules from the applicable shelf supplied by the breaker and attempt to reset it. <ul style="list-style-type: none"> – If the breaker trips again, there is probably a cable or breaker problem within the frame. – If the breaker does not trip, there is probably a defective module or sub-assembly within the shelf.
3	Verify that the C-CCP shelf breaker on the BTS frame breaker panel is functional.
4	Use a voltmeter to determine if the input voltage is being routed to the C-CCP backplane by measuring the DC voltage level on the PWR_IN cable. <ul style="list-style-type: none"> – If the voltage is not present, there is probably a cable or breaker problem within the frame. – If the voltage is present at the connector, reconnect and measure the level at the “VCC” power feed clip on the distribution backplane. – If the voltage is correct at the power clip, inspect the clip for damage.
5	If everything appears to be correct, visually inspect the power supply module connectors.
6	Replace the power supply module with a known good module.
7	If steps 1 through 5 fail to indicate a problem, a C-CCP backplane failure (possibly an open trace) has occurred.

C-CCP Backplane Troubleshooting – continued

No DC Voltage (+5, +6.5, or +15 Volts) to a Specific GLI2, BBX, or Switchboard

Perform the procedure in Table 6-23 to troubleshoot a DC input voltage to GLI2, BBX, or Switchboard failure.

Table 6-23: No DC Input Voltage to any C-CCP Shelf Module	
Step	Action
1	Verify the steps in Table 6-22 have been performed.
2	Inspect the defective board/module (both board and backplane) connector for damage.
3	Replace suspect board/module with known good board/module.

TX and RX Signal Routing Problems

Perform the procedure in Table 6-24 to troubleshoot TX and RX signal routing problems.

Table 6-24: TX and RX Signal Routing Problems	
Step	Action
1	Inspect all Harting Cable connectors and back-plane connectors for damage in all the affected board slots.
2	Perform steps in the RF path troubleshooting flowchart in this manual.

Module Front Panel LED Indicators and Connectors

Module Status Indicators

Each of the non-passive plug-in modules has a bi-color (green & red) LED status indicator located on the module front panel. The indicator is labeled PWR/ALM. If both colors are turned on, the indicator is yellow.

Each plug-in module, except for the fan module, has its own alarm (fault) detection circuitry that controls the state of the PWR/ALM LED.

The fan TACH signal of each fan module is monitored by the AMR. Based on the status of this signal, the AMR controls the state of the PWR/ALM LED on the fan module.

LED Status Combinations for All Modules (except GLI2, CSM, BBX, MCC)

PWR/ALM LED

The following list describes the states of the module status indicator.

- Solid GREEN – module operating in a normal (fault free) condition.
- Solid RED – module is operating in a fault (alarm) condition due to electrical hardware failure.

Note that a fault (alarm) indication may or may not be due to a complete module failure and normal service may or may not be reduced or interrupted.

6

DC/DC Converter LED Status Combinations

The PWR CNVTR has alarm (fault) detection circuitry that controls the state of the PWR/ALM LED. This is true for both the C-CCP and LPA power converters.

PWR/ALM LED

The following list describes the states of the bi-color LED.

- Solid GREEN – module operating in a normal (fault free) condition.
- Solid RED – module is operating in a fault (alarm) condition due to electrical hardware problem.

CSM LED Status Combinations

PWR/ALM LED

The CSMs include on-board alarm detection. Hardware and software/firmware alarms are indicated via the front panel indicators.

After the memory tests, the CSM loads OOS-RAM code from the Flash EPROM, if available. If not available, the OOS-ROM code is loaded from the Flash EPROM.

- Solid GREEN – module is INS_ACT or INS_STBY no alarm.
- Solid RED – Initial power up or module is operating in a fault (alarm) condition.
- Slowly Flashing GREEN – OOS_ROM no alarm.
- Long RED/Short GREEN – OOS_ROM alarm.
- Rapidly Flashing GREEN – OOS_RAM no alarm or INS_ACT in DUMB mode.
- Short RED/Short GREEN – OOS_RAM alarm.
- Long GREEN/Short RED – INS_ACT or INS_STBY alarm.
- Off – no DC power or on-board fuse is open.
- Solid YELLOW – After a reset, the CSMs begin to boot. During SRAM test and Flash EPROM code check, the LED is yellow. (If SRAM or Flash EPROM fail, the LED changes to a solid RED and the CSM attempts to reboot.)

Figure 6-1: CSM Front Panel Indicators & Monitor Ports

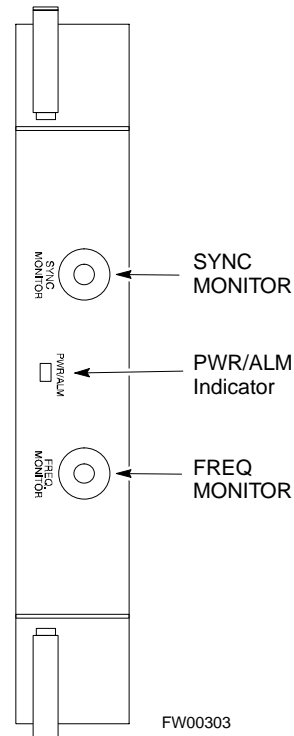

... continued on next page

FREQ Monitor Connector

A test port provided at the CSM front panel via a BNC receptacle allows monitoring of the 19.6608 MHz clock generated by the CSM. When both CSM 1 and CSM 2 are in an in-service (INS) condition, the CSM 2 clock signal frequency is the same as that output by CSM 1.

The clock is a sine wave signal with a minimum amplitude of +2 dBm (800 mVpp) into a 50 Ω load connected to this port.

SYNC Monitor Connector

A test port provided at the CSM front panel via a BNC receptacle allows monitoring of the “Even Second Tick” reference signal generated by the CSMs.

At this port, the reference signal is a TTL active high signal with a pulse width of 153 nanoseconds.

MMI Connector – Only accessible behind front panel. The RS-232 MMI port connector is intended to be used primarily in the development or factory environment, but may be used in the field for debug/maintenance purposes.

GLI2 LED Status Combinations

The GLI2 module has indicators, controls and connectors as described below and shown in Figure 6-2.

The operating states of the 5 LEDs are:

ACTIVE

Solid GREEN – GLI2 is active. This means that the GLI2 has shelf control and is providing control of the digital interfaces.

Off – GLI2 is not active (i.e., Standby). The mate GLI2 should be active.

MASTER

- Solid GREEN – GLI2 is Master (sometimes referred to as MGLI2).
- Off – GLI2 is non-master (i.e., Slave).

ALARM

- Solid RED – GLI2 is in a fault condition or in reset.
- While in reset transition, STATUS LED is OFF while GLI2 is performing ROM boot (about 12 seconds for normal boot).
- While in reset transition, STATUS LED is ON while GLI2 is performing RAM boot (about 4 seconds for normal boot).
- Off – No Alarm.

STATUS

- Flashing GREEN– GLI2 is in service (INS), in a stable operating condition.
- On – GLI2 is in OOS RAM state operating downloaded code.
- Off – GLI2 is in OOS ROM state operating boot code.

SPANS

- Solid GREEN – Span line is connected and operating.
- Solid RED – Span line is disconnected or a fault condition exists.

GLI2 Pushbuttons and Connectors

RESET Pushbutton – Depressing the RESET pushbutton causes a partial reset of the CPU and a reset of all board devices. The GLI2 is placed in the OOS_ROM state

MMI Connector – The RS-232MMI port connector is intended to be used primarily in the development or factory environment but may be used in the field for debug/maintenance purposes.

LAN Connectors (A & B) – The two 10BASE2 Ethernet circuit board mounted BNC connectors are located on the bottom front edge of the GLI2; one for each LAN interface, A & B. Ethernet cabling is connected to tee connectors fastened to these BNC connectors.

Figure 6-2: GLI2 Front Panel

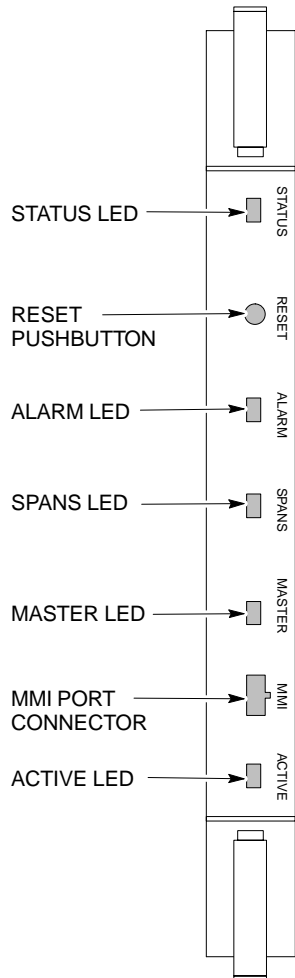

LED	OPERATING STATUS
STATUS	OFF – operating normally ON – briefly during power-up when the Alarm LED turns OFF. SLOW GREEN – when the GLI2 is INS (in-service)
RESET	All functions on the GLI2 are reset when pressing and releasing the switch.
ALARM	OFF – operating normally ON – briefly during power-up when the Alarm LED turns OFF. SLOW GREEN – when the GLI2 is INS (in-service)
SPANS	OFF – card is powered down, in initialization, or in standby GREEN – operating normally YELLOW – one or more of the equipped initialized spans is receiving a remote alarm indication signal from the far end RED – one or more of the equipped initialized spans is in an alarm state
MASTER	The pair of GLI2 cards include a redundant status. The card in the top shelf is designated by hardware as the active card; the card in the bottom shelf is in the standby mode. ON – operating normally in active card OFF – operating normally in standby card
MMI PORT CONNECTOR	An RS-232, serial, asynchronous communications link for use as an MMI port. This port supports 300 baud, up to a maximum of 115,200 baud communications.
ACTIVE	Shows the operating status of the redundant cards. The redundant card toggles automatically if the active card is removed or fails ON – active card operating normally OFF – standby card operating normally

FW00225

BBX LED Status Combinations

PWR/ALM LED

The BBX module has its own alarm (fault) detection circuitry that controls the state of the PWR/ALM LED.

The following list describes the states of the bi-color LED:

- Solid GREEN – INS_ACT no alarm
- Solid RED Red – initializing or power-up alarm
- Slowly Flashing GREEN – OOS_ROM no alarm
- Long RED/Short GREEN – OOS_ROM alarm
- Rapidly Flashing GREEN – OOS_RAM no alarm
- Short RED/Short GREEN – OOS_RAM alarm
- Long GREEN/Short RED – INS_ACT alarm

MCC LED Status Combinations

The MCC module has LED indicators and connectors as described below (see Figure 6-3). Note that the figure does not show the connectors as they are concealed by the removable lens.

The LED indicators and their states are as follows:

PWR/ALM LED

- RED – fault on module

ACTIVE LED

- Off – module is inactive, off-line, or not processing traffic.
- Slowly Flashing GREEN – OOS_ROM no alarm.
- Rapidly Flashing Green – OOS_RAM no alarm.
- Solid GREEN – module is INS_ACT, on-line, processing traffic.

PWR/ALM and ACTIVE LEDs

- Solid RED – module is powered but is in reset or the BCP is inactive.

MMI Connectors

- The RS–232 MMI port connector (four-pin) is intended to be used primarily in the development or factory environment but may be used in the field for debugging purposes.
- The RJ–11 ethernet port connector (eight-pin) is intended to be used primarily in the development environment but may be used in the field for high data rate debugging purposes.

. . . continued on next page

Figure 6-3: MCC Front Panel

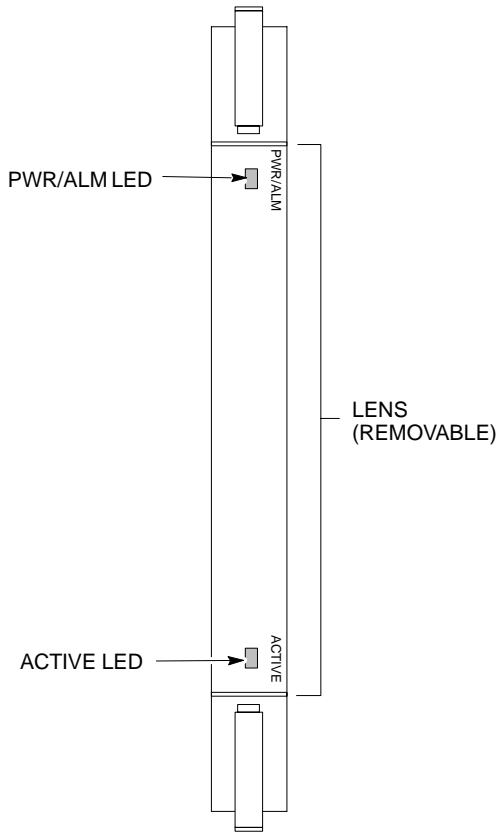

LED	COLOR	OPERATING STATUS
PWR/ALM	RED	OFF – operating normally ON – briefly during power-up and during failure conditions <i>An alarm is generated in the event of a failure</i>
ACTIVE	GREEN	RAPIDLY BLINKING – Card is code-loaded but not enabled SLOW BLINKING – Card is not code-loaded ON – card is code-loaded and enabled (INS_ACTIVE)
	RED	ON – fault condition SLOW FLASHING (alternating with green) – CHI bus inactive on power-up

FW00224

6

LPA Shelf LED Status Combinations

LPA Module LED

Each LPA module contains a bi-color LED just above the MMI connector on the front panel of the module. Interpret this LED as follows:

- GREEN — LPA module is active and is reporting no alarms (Normal condition).
- Flashing GREEN/RED — LPA module is active but is reporting an low input power condition. If no BBX is keyed, this is normal and does not constitute a failure.

Basic Troubleshooting – Span Control Link

Span Problems (No Control Link)

Perform the procedure in Table 6-25 to troubleshoot a control link failure.

Table 6-25: Troubleshooting Control Link Failure

✓	Step	Action
	1	Verify the span settings using the <code>span_view</code> command on the active master GLI2 MMI port. If these are correct, verify the <code>edlc</code> parameters using the <code>show</code> command. Any alarms conditions indicate that the span is not operating correctly. <ul style="list-style-type: none">– Try looping back the span line from the DSX panel back to the Mobility Manager (MM) and verify that the looped signal is good.– Listen for control tone on appropriate timeslot from Base Site and MM.
	2	If no traffic channels in groomed MCCs (or in whole C-CCP shelf) can process calls, verify that the ISB cabling is correct and that ISB A and ISB B cables are not swapped.

Appendix A: Data Sheets

Appendix Content

Optimization (Pre-ATP) Data Sheets	A-1
Verification of Test Equipment Used	A-1
Site Checklist	A-2
Preliminary Operations	A-2
Pre-Power and Initial Power Tests	A-3
General Optimization Checklist	A-4
GPS Receiver Operation	A-5
LFR Receiver Operation	A-6
LPA IM Reduction	A-7
LPA Convergence	A-8
TX Bay Level Offset / Power Output Verification for 3-Sector Configurations	A-9
TX Bay Level Offset / Power Output Verification for 6-Sector Configurations	A-14
BTS Redundancy/Alarm Tests	A-16
TX Antenna VSWR	A-16
RX Antenna VSWR	A-17
AMR Verification	A-17
Site Serial Number Check List	A-18
C-CCP Shelf	A-18
LPAs	A-19
Power Conversion Shelf (-48 V BTS Only)	A-19

Table of Contents – continued

Notes

Optimization (Pre-ATP) Data Sheets

Verification of Test Equipment Used

Table A-1: Verification of Test Equipment Used

Manufacturer	Model	Serial Number

Comments: _____

Optimization (Pre-ATP) Data Sheets – continued

Site Checklist

Table A-2: Site Checklist			
OK	Parameter	Specification	Comments
<input type="checkbox"/>	Deliveries	Per established procedures	
<input type="checkbox"/>	Floor Plan	Verified	
<input type="checkbox"/>	Inter Frame Cables:		
<input type="checkbox"/>	Ethernet	Per procedure	
<input type="checkbox"/>	Frame Ground	Per procedure	
<input type="checkbox"/>	Power	Per procedure	
<input type="checkbox"/>	Factory Data:		
<input type="checkbox"/>	BBX	Per procedure	
<input type="checkbox"/>	Test Panel	Per procedure	
<input type="checkbox"/>	RFDS	Per procedure	
<input type="checkbox"/>	Site Temperature		
<input type="checkbox"/>	Dress Covers/Brackets		

Preliminary Operations

Table A-3: Preliminary Operations			
OK	Parameter	Specification	Comments
<input type="checkbox"/>	Shelf ID Dip Switches	Per site equipage	
<input type="checkbox"/>	BBX Jumpers	Verified per procedure	
<input type="checkbox"/>	Ethernet LAN verification	Verified per procedure	

Comments: _____

Pre-Power and Initial Power Tests

Table A-4: Pre-power Checklist			
OK	Parameter	Specification	Comments
<input type="checkbox"/>	Pre-power-up tests	Verify power supply output voltage at the top of each BTS frame is within specifications	
<input type="checkbox"/>	Internal Cables:		
<input type="checkbox"/>	ISB (all cages)	verified	
<input type="checkbox"/>	CSM (all cages)	verified	
<input type="checkbox"/>	Power (all cages)	verified	
	Ethernet Connectors		
<input type="checkbox"/>	LAN A ohms	verified	
<input type="checkbox"/>	LAN B ohms	verified	
<input type="checkbox"/>	LAN A shield	isolated	
<input type="checkbox"/>	LAN B shield	isolated	
<input type="checkbox"/>	Ethernet Boots	installed	
<input type="checkbox"/>	Air Impedance Cage (single cage)	installed	
<input type="checkbox"/>	Initial power-up tests	Verify power supply output voltage at the top of each BTS frame is within specifications:	

Comments: _____

Optimization (Pre-ATP) Data Sheets – continued

General Optimization Checklist

Table A-5: Pre-power Checklist			
OK	Parameter	Specification	Comments
<input type="checkbox"/>	LEDs	illuminated	
<input type="checkbox"/>	Frame fans	operational	
<input type="checkbox"/>	LMF to BTS Connection		
<input type="checkbox"/>	Preparing the LMF	per procedure	
<input type="checkbox"/>	Log into the LMF PC	per procedure	
<input type="checkbox"/>	Create site specific BTS directory	per procedure	
<input type="checkbox"/>	Create master-bts-cdma directory	per procedure	
<input type="checkbox"/>	Download device loads	per procedure	
<input type="checkbox"/>	Moving/Linking files	per procedure	
<input type="checkbox"/>	Ping LAN A	per procedure	
<input type="checkbox"/>	Ping LAN B	per procedure	
<input type="checkbox"/>	Download/Enable MGLI2s	per procedure	
<input type="checkbox"/>	Download/Enable GLI2s	per procedure	
<input type="checkbox"/>	Set Site Span Configuration	per procedure	
<input type="checkbox"/>	Download CSMs	per procedure	
<input type="checkbox"/>	Download	per procedure	
<input type="checkbox"/>	Enable CSMs	per procedure	
<input type="checkbox"/>	Download/Enable MCCs	per procedure	
<input type="checkbox"/>	Download BBXs	per procedure	
<input type="checkbox"/>	Download TSU (in RFDS)	per procedure	
<input type="checkbox"/>	Program TSU NAM	per procedure	
<input type="checkbox"/>	Test Set Calibration	per procedure	

Comments: _____

GPS Receiver Operation

Table A-6: GPS Receiver Operation			
OK	Parameter	Specification	Comments
<input type="checkbox"/>	GPS Receiver Control Task State: tracking satellites	Verify parameter	
<input type="checkbox"/>	Initial Position Accuracy:	Verify Estimated or Surveyed	
<input type="checkbox"/>	Current Position: lat lon height	RECORD in ms and cm also convert to deg min sec	
<input type="checkbox"/>	Current Position: satellites tracked Estimated: (>4) satellites tracked,(>4) satellites visible Surveyed: (≥1) satellite tracked,(>4) satellites visible	Verify parameter as appropriate:	
<input type="checkbox"/>	GPS Receiver Status:Current Dilution of Precision (PDOP or HDOP): (<30)	Verify parameter	
<input type="checkbox"/>	Current reference source: Number: 0; Status: Good; Valid: Yes	Verify parameter	

Comments: _____

Optimization (Pre-ATP) Data Sheets – continued

LFR Receiver Operation

Table A-7: LFR Receiver Operation			
OK	Parameter	Specification	Comments
<input type="checkbox"/>	Station call letters M X Y Z assignment.	as specified in site documentation	
<input type="checkbox"/>	SN ratio is > 8 dB		
<input type="checkbox"/>	LFR Task State: 1fr locked to station xxxx	Verify parameter	
<input type="checkbox"/>	Current reference source: Number: 1; Status: Good; Valid: Yes	Verify parameter	

Comments: _____

LPA IM Reduction

Table A-8: LPA IM Reduction							
OK	Parameter					Specification	Comments
	LPA #	CARRIER					
		4:1 & 2:1 3-Sector	2:1 6-Sector	Dual BP 3-Sector	Dual BP 6-Sector		
<input type="checkbox"/>	1A	C1	C1	C1	C1	No Alarms	
<input type="checkbox"/>	1B	C1	C1	C1	C1	No Alarms	
<input type="checkbox"/>	1C	C1	C1	C1	C1	No Alarms	
<input type="checkbox"/>	1D	C1	C1	C1	C1	No Alarms	
<input type="checkbox"/>	2A	C2	C2	C2		No Alarms	
<input type="checkbox"/>	2B	C2	C2	C2		No Alarms	
<input type="checkbox"/>	2C	C2	C2	C2		No Alarms	
<input type="checkbox"/>	2D	C2	C2	C2		No Alarms	
<input type="checkbox"/>	3A	C3	C1		C1	No Alarms	
<input type="checkbox"/>	3B	C3	C1		C1	No Alarms	
<input type="checkbox"/>	3C	C3	C1		C1	No Alarms	
<input type="checkbox"/>	3D	C3	C1		C1	No Alarms	
<input type="checkbox"/>	4A	C4	C2			No Alarms	
<input type="checkbox"/>	4B	C4	C2			No Alarms	
<input type="checkbox"/>	4C	C4	C2			No Alarms	
<input type="checkbox"/>	4D	C4	C2			No Alarms	

Comments: _____

Cx – denotes physical carriers

For applied frequency requirements, see Appendix E.

Optimization (Pre-ATP) Data Sheets – continued

LPA Convergence

Table A-9: LPA Convergence			
OK	Parameter	Specification	Data
	LPA # Converged		
<input type="checkbox"/>	1A	Verify per procedure & upload convergence data	
<input type="checkbox"/>	1B		
<input type="checkbox"/>	1C		
<input type="checkbox"/>	1D		
<input type="checkbox"/>	2A	Verify per procedure & upload convergence data	
<input type="checkbox"/>	2B		
<input type="checkbox"/>	2C		
<input type="checkbox"/>	2D		
<input type="checkbox"/>	3A	Verify per procedure & upload convergence data	
<input type="checkbox"/>	3B		
<input type="checkbox"/>	3C		
<input type="checkbox"/>	3D		
<input type="checkbox"/>	4A	Verify per procedure & upload convergence data	
<input type="checkbox"/>	4B		
<input type="checkbox"/>	4C		
<input type="checkbox"/>	4D		

**TX Bay Level Offset/Power
Output Verification for
3-Sector Configurations**

**1-Carrier
2-Carrier Non-adjacent Channels
4-Carrier Non-adjacent Channels**

Table A-10: TX BLO Calibration (3-Sector: 1-Carrier, 2-Carrier and 4-Carrier Non-adjacent Channels)

OK	Parameter	Specification	Comments
<input type="checkbox"/>	Calibrate carrier 1	TX Bay Level Offset = 42 dB (± 4 dB) prior to calibration	BBX-1, ANT-1 = ___ dB BBX-r, ANT-1 = ___ dB
<input type="checkbox"/>			BBX-2, ANT-2 = ___ dB BBX-r, ANT-2 = ___ dB
<input type="checkbox"/>			BBX-3, ANT-3 = ___ dB BBX-r, ANT-3 = ___ dB
<input type="checkbox"/>	Calibrate carrier 2	TX Bay Level Offset = 42 dB (± 4 dB) prior to calibration	BBX-7, ANT-1 = ___ dB BBX-r, ANT-1 = ___ dB
<input type="checkbox"/>			BBX-8, ANT-2 = ___ dB BBX-r, ANT-2 = ___ dB
<input type="checkbox"/>			BBX-9, ANT-3 = ___ dB BBX-r, ANT-3 = ___ dB
<input type="checkbox"/>	Calibrate carrier 3	TX Bay Level Offset = 42 dB (± 4 dB) prior to calibration	BBX-4, ANT-1 = ___ dB BBX-r, ANT-1 = ___ dB
<input type="checkbox"/>			BBX-5, ANT-2 = ___ dB BBX-r, ANT-2 = ___ dB
<input type="checkbox"/>			BBX-6, ANT-3 = ___ dB BBX-r, ANT-3 = ___ dB
<input type="checkbox"/>	Calibrate carrier 4	TX Bay Level Offset = 42 dB (± 4 dB) prior to calibration	BBX-10, ANT-1 = ___ dB BBX-r, ANT-1 = ___ dB
<input type="checkbox"/>			BBX-11, ANT-2 = ___ dB BBX-r, ANT-2 = ___ dB
<input type="checkbox"/>			BBX-12, ANT-3 = ___ dB BBX-r, ANT-3 = ___ dB

... continued on next page

Optimization (Pre-ATP) Data Sheets – continued

Table A-10: TX BLO Calibration (3-Sector: 1-Carrier, 2-Carrier and 4-Carrier Non-adjacent Channels)

OK	Parameter	Specification	Comments
<input type="checkbox"/>	Calibration Audit carrier 1	0 dB (± 0.5 dB) for gain set resolution post calibration	BBX-1, ANT-1 = ___ dB BBX-r, ANT-1 = ___ dB
<input type="checkbox"/>			BBX-2, ANT-2 = ___ dB BBX-r, ANT-2 = ___ dB
<input type="checkbox"/>			BBX-3, ANT-3 = ___ dB BBX-r, ANT-3 = ___ dB
<input type="checkbox"/>	Calibration Audit carrier 2	0 dB (± 0.5 dB) for gain set resolution post calibration	BBX-7, ANT-1 = ___ dB BBX-r, ANT-1 = ___ dB
<input type="checkbox"/>			BBX-8, ANT-2 = ___ dB BBX-r, ANT-2 = ___ dB
<input type="checkbox"/>			BBX-9, ANT-3 = ___ dB BBX-r, ANT-3 = ___ dB
<input type="checkbox"/>	Calibration Audit carrier 3	0 dB (± 0.5 dB) for gain set resolution post calibration	BBX-4, ANT-1 = ___ dB BBX-r, ANT-1 = ___ dB
<input type="checkbox"/>			BBX-5, ANT-2 = ___ dB BBX-r, ANT-2 = ___ dB
<input type="checkbox"/>			BBX-6, ANT-3 = ___ dB BBX-r, ANT-3 = ___ dB
<input type="checkbox"/>	Calibration Audit carrier 4	0 dB (± 0.5 dB) for gain set resolution post calibration	BBX-10, ANT-1 = ___ dB BBX-r, ANT-1 = ___ dB
<input type="checkbox"/>			BBX-11, ANT-2 = ___ dB BBX-r, ANT-2 = ___ dB
<input type="checkbox"/>			BBX-12, ANT-3 = ___ dB BBX-r, ANT-3 = ___ dB

Comments: _____

2-Carrier Adjacent Channel

Table A-11: TX Bay Level Offset Calibration (3-Sector: 2-Carrier Adjacent Channels)			
OK	Parameter	Specification	Comments
<input type="checkbox"/>	Calibrate carrier 1	TX Bay Level Offset = 42 dB (typical), 38 dB (minimum) prior to calibration	BBX-1, ANT-1 = ___ dB BBX-r, ANT-1 = ___ dB
<input type="checkbox"/>			BBX-2, ANT-2 = ___ dB BBX-r, ANT-2 = ___ dB
<input type="checkbox"/>			BBX-3, ANT-3 = ___ dB BBX-r, ANT-3 = ___ dB
<input type="checkbox"/>	Calibrate carrier 2	TX Bay Level Offset = 42 dB (typical), 38 dB (minimum) prior to calibration	BBX-7, ANT-4 = ___ dB BBX-r, ANT-4 = ___ dB
<input type="checkbox"/>			BBX-8, ANT-5 = ___ dB BBX-r, ANT-5 = ___ dB
<input type="checkbox"/>			BBX-9, ANT-6 = ___ dB BBX-r, ANT-6 = ___ dB
<input type="checkbox"/>	Calibration Audit carrier 1	0 dB (± 0.5 dB) for gain set resolution post calibration	BBX-1, ANT-1 = ___ dB BBX-r, ANT-1 = ___ dB
<input type="checkbox"/>			BBX-2, ANT-2 = ___ dB BBX-r, ANT-2 = ___ dB
<input type="checkbox"/>			BBX-3, ANT-3 = ___ dB BBX-r, ANT-3 = ___ dB
<input type="checkbox"/>	Calibration Audit carrier 2	0 dB (± 0.5 dB) for gain set resolution post calibration	BBX-7, ANT-4 = ___ dB BBX-r, ANT-4 = ___ dB
<input type="checkbox"/>			BBX-8, ANT-5 = ___ dB BBX-r, ANT-5 = ___ dB
<input type="checkbox"/>			BBX-9, ANT-6 = ___ dB BBX-r, ANT-6 = ___ dB

Comments: _____

3-Carrier Adjacent Channels
4-Carrier Adjacent Channels

Table A-12: TX Bay Level Offset Calibration (3-Sector: 3 or 4-Carrier Adjacent Channels)

OK	Parameter	Specification	Comments
<input type="checkbox"/>	Calibrate carrier 1	TX Bay Level Offset = 42 dB (± 4 dB) prior to calibration	BBX-1, ANT-1 = ___ dB BBX-r, ANT-1 = ___ dB
<input type="checkbox"/>			BBX-2, ANT-2 = ___ dB BBX-r, ANT-2 = ___ dB
<input type="checkbox"/>			BBX-3, ANT-3 = ___ dB BBX-r, ANT-3 = ___ dB
<input type="checkbox"/>	Calibrate carrier 2	TX Bay Level Offset = 42 dB (± 4 dB) prior to calibration	BBX-7, ANT-1 = ___ dB BBX-r, ANT-1 = ___ dB
<input type="checkbox"/>			BBX-8, ANT-2 = ___ dB BBX-r, ANT-2 = ___ dB
<input type="checkbox"/>			BBX-9, ANT-3 = ___ dB BBX-r, ANT-3 = ___ dB
<input type="checkbox"/>	Calibrate carrier 3	TX Bay Level Offset = 42 dB (± 4 dB) prior to calibration	BBX-4, ANT-4 = ___ dB BBX-r, ANT-4 = ___ dB
<input type="checkbox"/>			BBX-5, ANT-5 = ___ dB BBX-r, ANT-5 = ___ dB
<input type="checkbox"/>			BBX-6, ANT-6 = ___ dB BBX-r, ANT-6 = ___ dB
<input type="checkbox"/>	Calibrate carrier 4	TX Bay Level Offset = 42 dB (± 4 dB) prior to calibration	BBX-10, ANT-4 = ___ dB BBX-3, ANT-4 = ___ dB
<input type="checkbox"/>			BBX-11, ANT-5 = ___ dB BBX-r, ANT-5 = ___ dB
<input type="checkbox"/>			BBX-12, ANT-6 = ___ dB BBX-r, ANT-6 = ___ dB
<input type="checkbox"/>	Calibration Audit carrier 1	0 dB (± 0.5 dB) for gain set resolution post calibration	BBX-1, ANT-1 = ___ dB BBX-r, ANT-1 = ___ dB
<input type="checkbox"/>			BBX-2, ANT-2 = ___ dB BBX-r, ANT-2 = ___ dB
<input type="checkbox"/>			BBX-3, ANT-3 = ___ dB BBX-r, ANT-3 = ___ dB

... continued on next page

Table A-12: TX Bay Level Offset Calibration (3-Sector: 3 or 4-Carrier Adjacent Channels)

OK	Parameter	Specification	Comments
<input type="checkbox"/>	Calibration Audit carrier 2	0 dB (± 0.5 dB) for gain set resolution post calibration	BBX-7, ANT-1 = ___ dB BBX-r, ANT-1 = ___ dB
<input type="checkbox"/>			BBX-8, ANT-2 = ___ dB BBX-r, ANT-2 = ___ dB
<input type="checkbox"/>			BBX-9, ANT-3 = ___ dB BBX-r, ANT-3 = ___ dB
<input type="checkbox"/>	Calibration Audit carrier 3	0 dB (± 0.5 dB) for gain set resolution post calibration	BBX-4, ANT-4 = ___ dB BBX-r, ANT-4 = ___ dB
<input type="checkbox"/>			BBX-5, ANT-5 = ___ dB BBX-r, ANT-5 = ___ dB
<input type="checkbox"/>			BBX-6, ANT-6 = ___ dB BBX-r, ANT-6 = ___ dB
<input type="checkbox"/>	Calibration Audit carrier 4	0 dB (± 0.5 dB) for gain set resolution post calibration	BBX-10, ANT-4 = ___ dB BBX-r, ANT-4 = ___ dB
<input type="checkbox"/>			BBX-11, ANT-5 = ___ dB BBX-r, ANT-5 = ___ dB
<input type="checkbox"/>			BBX-12, ANT-6 = ___ dB BBX-r, ANT-6 = ___ dB

Comments: _____



Optimization (Pre-ATP) Data Sheets – continued

TX Bay Level Offset/Power Output Verification for 6-Sector Configurations

1-Carrier 2-Carrier Non-adjacent Channels

Table A-13: TX BLO Calibration (6-Sector: 1-Carrier, 2-Carrier Non-adjacent Channels)			
OK	Parameter	Specification	Comments
<input type="checkbox"/>	Calibrate carrier 1	TX Bay Level Offset = 42 dB (typical), 38 dB (minimum) prior to calibration	BBX-1, ANT-1 = ___ dB
<input type="checkbox"/>			BBX-r, ANT-1 = ___ dB
<input type="checkbox"/>			BBX-2, ANT-2 = ___ dB
<input type="checkbox"/>			BBX-r, ANT-2 = ___ dB
<input type="checkbox"/>			BBX-3, ANT-3 = ___ dB
<input type="checkbox"/>			BBX-r, ANT-3 = ___ dB
<input type="checkbox"/>	Calibrate carrier 2	TX Bay Level Offset = 42 dB (typical), 38 dB (minimum) prior to calibration	BBX-4, ANT-4 = ___ dB
<input type="checkbox"/>			BBX-r, ANT-4 = ___ dB
<input type="checkbox"/>			BBX-5, ANT-5 = ___ dB
<input type="checkbox"/>			BBX-r, ANT-5 = ___ dB
<input type="checkbox"/>			BBX-6, ANT-6 = ___ dB
<input type="checkbox"/>			BBX-r, ANT-6 = ___ dB
<input type="checkbox"/>			BBX-7, ANT-1 = ___ dB
<input type="checkbox"/>			BBX-r, ANT-1 = ___ dB
<input type="checkbox"/>			BBX-8, ANT-2 = ___ dB
<input type="checkbox"/>			BBX-r, ANT-2 = ___ dB
<input type="checkbox"/>			BBX-9, ANT-3 = ___ dB
<input type="checkbox"/>			BBX-r, ANT-3 = ___ dB
<input type="checkbox"/>			BBX-10, ANT-4 = ___ dB
<input type="checkbox"/>			BBX-3, ANT-4 = ___ dB
<input type="checkbox"/>			BBX-11, ANT-5 = ___ dB
<input type="checkbox"/>			BBX-r, ANT-5 = ___ dB
<input type="checkbox"/>			BBX-12, ANT-6 = ___ dB
<input type="checkbox"/>			BBX-r, ANT-5 = ___ dB

... continued on next page

Table A-13: TX BLO Calibration (6-Sector: 1-Carrier, 2-Carrier Non-adjacent Channels)

OK	Parameter	Specification	Comments
<input type="checkbox"/>	Calibration Audit carrier 1	0 dB (± 0.5 dB) for gain set resolution post calibration	BBX-1, ANT-1 = ___ dB BBX-r, ANT-1 = ___ dB
<input type="checkbox"/>			BBX-2, ANT-2 = ___ dB BBX-r, ANT-2 = ___ dB
<input type="checkbox"/>			BBX-3, ANT-3 = ___ dB BBX-r, ANT-3 = ___ dB
<input type="checkbox"/>			BBX-4, ANT-4 = ___ dB BBX-r, ANT-4 = ___ dB
<input type="checkbox"/>			BBX-5, ANT-5 = ___ dB BBX-r, ANT-5 = ___ dB
<input type="checkbox"/>			BBX-6, ANT-6 = ___ dB BBX-r, ANT-6 = ___ dB
<input type="checkbox"/>	Calibration Audit carrier 2	0 dB (± 0.5 dB) for gain set resolution post calibration	BBX-7, ANT-1 = ___ dB BBX-r, ANT-1 = ___ dB
<input type="checkbox"/>			BBX-8, ANT-2 = ___ dB BBX-r, ANT-2 = ___ dB
<input type="checkbox"/>			BBX-9, ANT-3 = ___ dB BBX-r, ANT-3 = ___ dB
<input type="checkbox"/>			BBX-10, ANT-4 = ___ dB BBX-r, ANT-4 = ___ dB
<input type="checkbox"/>			BBX-11, ANT-5 = ___ dB BBX-r, ANT-5 = ___ dB
<input type="checkbox"/>			BBX-12, ANT-6 = ___ dB BBX-r, ANT-6 = ___ dB

Comments: _____

Optimization (Pre-ATP) Data Sheets – continued

BTS Redundancy/Alarm Tests

Table A-14: BTS Redundancy/Alarm Tests			
OK	Parameter	Specification	Data
<input type="checkbox"/>	SIF: Misc. alarm tests	Verify per procedure	
<input type="checkbox"/>	MGLI2 redundancy test	Verify per procedure	
<input type="checkbox"/>	GLI2 redundancy test	Verify per procedure	
<input type="checkbox"/>	Power supply/converter redundancy	Verify per procedure	
<input type="checkbox"/>	Misc. alarm tests	Verify per procedure	
<input type="checkbox"/>	CSM, GPS, & LFR redundancy/alarm tests	Verify per procedure	
<input type="checkbox"/>	LPA redundancy test	Verify per procedure	

Comments: _____

TX Antenna VSWR

Table A-15: TX Antenna VSWR			
OK	Parameter	Specification	Data
<input type="checkbox"/>	VSWR – Antenna 1	< (1.5 : 1)	
<input type="checkbox"/>	VSWR – Antenna 2	< (1.5 : 1)	
<input type="checkbox"/>	VSWR – Antenna 3	< (1.5 : 1)	
<input type="checkbox"/>	VSWR – Antenna 4	< (1.5 : 1)	
<input type="checkbox"/>	VSWR – Antenna 5	< (1.5 : 1)	
<input type="checkbox"/>	VSWR – Antenna 6	< (1.5 : 1)	

Comments: _____

RX Antenna VSWR

Table A-16: RX Antenna VSWR			
OK	Parameter	Specification	Data
<input type="checkbox"/>	VSWR – Antenna 1	< (1.5 : 1)	
<input type="checkbox"/>	VSWR – Antenna 2	< (1.5 : 1)	
<input type="checkbox"/>	VSWR – Antenna 3	< (1.5 : 1)	
<input type="checkbox"/>	VSWR – Antenna 4	< (1.5 : 1)	
<input type="checkbox"/>	VSWR – Antenna 5	< (1.5 : 1)	
<input type="checkbox"/>	VSWR – Antenna 6	< (1.5 : 1)	

Comments: _____

AMR Verification

Table A-17: AMR CDI Alarm Input Verification			
OK	Parameter	Specification	Data
<input type="checkbox"/>	Verify CDI alarm input operation (“ALARM A” (numbers 1 –18)	BTS Relay #XX – Contact Alarm Sets/Clears	
<input type="checkbox"/>	Verify CDI alarm input operation (“ALARM B” (numbers 19 –36)	BTS Relay #XX – Contact Alarm Sets/Clears	

Comments: _____



Site Serial Number Check List

Date _____

Site _____

C-CCP Shelf

Site I/O A & B

C-CCP Shelf

CSM-1

CSM-2

HSO

CCD-1

CCD-2

AMR-1

AMR-2

MPC-1

MPC-2

Fans 1-3

GLI2-1

GLI2-2

BBX-1

BBX-2

BBX-3

BBX-4

BBX-5

BBX-6

BBX-7

BBX-8

BBX-9

BBX-10

BBX-11

BBX-12

BBX-r

MCC-1

MCC-2

MCC-3

MCC-4

MCC-5

MCC-6

MCC-7

MCC-8

MCC-9

Horizontal lines for data entry corresponding to each component name.

. . . continued on next page

Site Serial Number Check List – continued



MCC-1-10 _____
MCC-11 _____
MCC-1-12 _____
CIO _____
SWITCH _____
PS-1 _____
PS-2 _____
PS-3 _____

LPAs

LPA 1A _____
LPA 1B _____
LPA 1C _____
LPA 1D _____
LPA 2A _____
LPA 2B _____
LPA 2C _____
LPA 2D _____
LPA 3A _____
LPA 3B _____
LPA 3C _____
LPA 3D _____
LPA 4A _____
LPA 4B _____
LPA 4C _____
LPA 4D _____

**Power Conversion Shelf
(-48 V BTS Only)**

AMR _____
PS 4 _____
PS 5 _____
PS 6 _____
PS 7 _____
PS 8 _____
PS 9 _____

Appendix B: PN Offset/I & Q Offset Register Programming Information



Appendix Content

Appendix B: PN Offset Programming Information	B-1
PN Offset Background	B-1
PN Offset Usage	B-1

Table of Contents – continued

Notes



PN Offset Programming Information

PN Offset Background

All channel elements transmitted from a BTS in a particular 1.25 MHz CDMA channel are orthonogonally spread by 1 of 64 possible Walsh code functions; additionally, they are also spread by a quadrature pair of PN sequences unique to each sector.

Overall, the mobile uses this to differentiate multiple signals transmitted from the same BTS (and surrounding BTS) sectors, and to synchronize to the next strongest sector.

The PN offset per sector is stored on the BBXs, where the corresponding I & Q registers reside.

The PN offset values are determined on a per BTS/per sector(antenna) basis as determined by the appropriate cdf file content. A breakdown of this information is found in Table B-1.

PN Offset Usage

Only the 14–chip delay is currently in use. It is important to determine the RF chip delay to be able to test the BTS functionality. This can be done by ascertaining if the CDF file `FineTxAdj` value was set to “on” when the MCC was downloaded with “image data”. The `FineTxAdj` value is used to compensate for the processing delay (approximately 20 μ S) in the BTS using any type of mobile meeting IS–97 specifications.

If the `FineTxAdj` value in the cdf file is 213 (D5 HEX), `FineTxAdj` has been set for the *14 chip table*.



IMPORTANT

CDF file I and Q values can be represented in DECIMAL or HEX. If using HEX, add 0x before the HEX value. If necessary, convert HEX values in Table B-1 to decimal before comparing them to cdf file I & Q value assignments.

PN Offset Programming Information – continued

B

Table B-1: PnMask I and PnMask Q Values for PilotPn				
14-Chip Delay				
Pilot PN	I (Dec.)	Q	I (Hex.)	Q
0	17523	23459	4473	5BA3
1	32292	32589	7E24	7F4D
2	4700	17398	125C	43F6
3	14406	26333	3846	66DD
4	14899	4011	3A33	0FAB
5	17025	2256	4281	08D0
6	14745	18651	3999	48DB
7	2783	1094	0ADF	0446
8	5832	21202	16C8	52D2
9	12407	13841	3077	3611
10	31295	31767	7A3F	7C17
11	7581	18890	1D9D	49CA
12	18523	30999	485B	7917
13	29920	22420	74E0	5794
14	25184	20168	6260	4EC8
15	26282	12354	66AA	3042
16	30623	11187	779F	2BB3
17	15540	11834	3CB4	2E3A
18	23026	10395	59F2	289B
19	20019	28035	4E33	6D83
20	4050	27399	0FD2	6B07
21	1557	22087	0615	5647
22	30262	2077	7636	081D
23	18000	13758	4650	35BE
24	20056	11778	4E58	2E02
25	12143	3543	2F6F	0DD7
26	17437	7184	441D	1C10
27	17438	2362	441E	093A
28	5102	25840	13EE	64F0
29	9302	12177	2456	2F91
30	17154	10402	4302	28A2
31	5198	1917	144E	077D
32	4606	17708	11FE	452C
33	24804	10630	60E4	2986
34	17180	6812	431C	1A9C
35	10507	14350	290B	380E
36	10157	10999	27AD	2AF7
37	23850	25003	5D2A	61AB
38	31425	2652	7AC1	0A5C
39	4075	19898	0FEB	4DBA
40	10030	2010	272E	07DA
41	16984	25936	4258	6550
42	14225	28531	3791	6F73
43	26519	11952	6797	2EB0
44	27775	31947	6C7F	7CCB
45	30100	25589	7594	63F5
46	7922	11345	1EF2	2C51
47	14199	28198	3777	6E26
48	17637	13947	44E5	367B
49	23081	8462	5A29	210E
50	5099	9595	13EB	257B

... continued on next page

PN Offset Programming Information – continued

Table B-1: PnMask I and PnMask Q Values for PilotPn				
14-Chip Delay				
Pilot PN	I (Dec.)	Q	I (Hex.)	Q
51	32743	4670	7FE7	123E
52	7114	14672	1BCA	3950
53	7699	29415	1E13	72E7
54	19339	20610	4B8B	5082
55	28212	6479	6E34	194F
56	29587	10957	7393	2ACD
57	19715	18426	4D03	47FA
58	14901	22726	3A35	58C6
59	20160	5247	4EC0	147F
60	22249	29953	56E9	7501
61	26582	5796	67D6	16A4
62	7153	16829	1BF1	41BD
63	15127	4528	3B17	11B0
64	15274	5415	3BAA	1527
65	23149	10294	5A6D	2836
66	16340	17046	3FD4	4296
67	27052	7846	69AC	1EA6
68	13519	10762	34CF	2A0A
69	10620	13814	297C	35F6
70	15978	16854	3E6A	41D6
71	27966	795	6D3E	031B
72	12479	9774	30BF	262E
73	1536	24291	0600	5EE3
74	3199	3172	0C7F	0C64
75	4549	2229	11C5	08B5
76	17888	21283	45E0	5323
77	13117	16905	333D	4209
78	7506	7062	1D52	1B96
79	27626	7532	6BEA	1D6C
80	31109	25575	7985	63E7
81	29755	14244	743B	37A4
82	26711	28053	6857	6D95
83	20397	30408	4FAD	76C8
84	18608	5094	48B0	13E6
85	7391	16222	1CDF	3F5E
86	23168	7159	5A80	1BF7
87	23466	174	5BAA	00AE
88	15932	25530	3E3C	63BA
89	25798	2320	64C6	0910
90	28134	23113	6DE6	5A49
91	28024	23985	6D78	5DB1
92	6335	2604	18BF	0A2C
93	21508	1826	5404	0722
94	26338	30853	66E2	7885
95	17186	15699	4322	3D53
96	22462	2589	57BE	0A1D
97	3908	25000	0F44	61A8
98	25390	18163	632E	46F3
99	27891	12555	6CF3	310B
100	9620	8670	2594	21DE

... continued on next page



PN Offset Programming Information – continued

B

Table B-1: PnMask I and PnMask Q Values for PilotPn				
14-Chip Delay				
Pilot PN	I (Dec.)	Q	I (Hex.)	Q
101	6491	1290	195B	050A
102	16876	4407	41EC	1137
103	17034	1163	428A	048B
104	32405	12215	7E95	2FB7
105	27417	7253	6B19	1C55
106	8382	8978	20BE	2312
107	5624	25547	15F8	63CB
108	1424	3130	0590	0C3A
109	13034	31406	32EA	7AAE
110	15682	6222	3D42	184E
111	27101	20340	69DD	4F74
112	8521	25094	2149	6206
113	30232	23380	7618	5B54
114	6429	10926	191D	2AAE
115	27116	22821	69EC	5925
116	4238	31634	108E	7B92
117	5128	4403	1408	1133
118	14846	689	39FE	02B1
119	13024	27045	32E0	69A5
120	10625	27557	2981	6BA5
121	31724	16307	7BEC	3FB3
122	13811	22338	35F3	5742
123	24915	27550	6153	6B9E
124	1213	22096	04BD	5650
125	2290	23136	08F2	5A60
126	31551	12199	7B3F	2FA7
127	12088	1213	2F38	04BD
128	7722	936	1E2A	03A8
129	27312	6272	6AB0	1880
130	23130	32446	5A5A	7EBE
131	594	13555	0252	34F3
132	25804	8789	64CC	2255
133	31013	24821	7925	60F5
134	32585	21068	7F49	524C
135	3077	31891	0C05	7C93
136	17231	5321	434F	14C9
137	31554	551	7B42	0227
138	8764	12115	223C	2F53
139	15375	4902	3C0F	1326
140	13428	1991	3474	07C7
141	17658	14404	44FA	3844
142	13475	17982	34A3	463E
143	22095	19566	564F	4C6E
144	24805	2970	60E5	0B9A
145	4307	23055	10D3	5A0F
146	23292	15158	5AFC	3B36
147	1377	29094	0561	71A6
148	28654	653	6FEE	028D
149	6350	19155	18CE	4AD3
150	16770	23588	4182	5C24

... continued on next page

PN Offset Programming Information – continued

Table B-1: PnMask I and PnMask Q Values for PilotPn				
14-Chip Delay				
Pilot PN	I (Dec.)	Q	I	Q
			(Hex.)	
151	14726	10878	3986	2A7E
152	25685	31060	6455	7954
153	21356	30875	536C	789B
154	12149	11496	2F75	2CE8
155	28966	24545	7126	5FE1
156	22898	9586	5972	2572
157	1713	20984	06B1	51F8
158	30010	30389	753A	76B5
159	2365	7298	093D	1C82
160	27179	18934	6A2B	49F6
161	29740	23137	742C	5A61
162	5665	24597	1621	6015
163	23671	23301	5C77	5B05
164	1680	7764	0690	1E54
165	25861	14518	6505	38B6
166	25712	21634	6470	5482
167	19245	11546	4B2D	2D1A
168	26887	26454	6907	6756
169	30897	15938	78B1	3E42
170	11496	9050	2CE8	235A
171	1278	3103	04FE	0C1F
172	31555	758	7B43	02F6
173	29171	16528	71F3	4090
174	20472	20375	4FF8	4F97
175	5816	10208	16B8	27E0
176	30270	17698	763E	4522
177	22188	8405	56AC	20D5
178	6182	28634	1826	6FDA
179	32333	1951	7E4D	079F
180	14046	20344	36DE	4F78
181	15873	26696	3E01	6848
182	19843	3355	4D83	0D1B
183	29367	11975	72B7	2EC7
184	13352	31942	3428	7CC6
185	22977	9737	59C1	2609
186	31691	9638	7BCB	25A6
187	10637	30643	298D	77B3
188	25454	13230	636E	33AE
189	18610	22185	48B2	56A9
190	6368	2055	18E0	0807
191	7887	8767	1ECF	223F
192	7730	15852	1E32	3DEC
193	23476	16125	5BB4	3EFD
194	889	6074	0379	17BA
195	21141	31245	5295	7A0D
196	20520	15880	5028	3E08
197	21669	20371	54A5	4F93
198	15967	8666	3E5F	21DA
199	21639	816	5487	0330
200	31120	22309	7990	5725

... continued on next page



PN Offset Programming Information – continued

B

Table B-1: PnMask I and PnMask Q Values for PilotPn				
14-Chip Delay				
Pilot PN	I (Dec.)	Q	I (Hex.)	Q
201	3698	29563	0E72	737B
202	16322	13078	3FC2	3316
203	17429	10460	4415	28DC
204	21730	17590	54E2	44B6
205	17808	20277	4590	4F35
206	30068	19988	7574	4E14
207	12737	6781	31C1	1A7D
208	28241	32501	6E51	7EF5
209	20371	6024	4F93	1788
210	13829	20520	3605	5028
211	13366	31951	3436	7CCF
212	25732	26063	6484	65CF
213	19864	27203	4D98	6A43
214	5187	6614	1443	19D6
215	23219	10970	5AB3	2ADA
216	28242	5511	6E52	1587
217	6243	17119	1863	42DF
218	445	16064	01BD	3EC0
219	21346	31614	5362	7B7E
220	13256	4660	33C8	1234
221	18472	13881	4828	3639
222	25945	16819	6559	41B3
223	31051	6371	794B	18E3
224	1093	24673	0445	6061
225	5829	6055	16C5	17A7
226	31546	10009	7B3A	2719
227	29833	5957	7489	1745
228	18146	11597	46E2	2D4D
229	24813	22155	60ED	568B
230	47	15050	002F	3ACA
231	3202	16450	0C82	4042
232	21571	27899	5443	6CFB
233	7469	2016	1D2D	07E0
234	25297	17153	62D1	4301
235	8175	15849	1FEF	3DE9
236	28519	30581	6F67	7775
237	4991	3600	137F	0E10
238	7907	4097	1EE3	1001
239	17728	671	4540	029F
240	14415	20774	384F	5126
241	30976	24471	7900	5F97
242	26376	27341	6708	6ACD
243	19063	19388	4A77	4BBC
244	19160	25278	4AD8	62BE
245	3800	9505	0ED8	2521
246	8307	26143	2073	661F
247	12918	13359	3276	342F
248	19642	2154	4CBA	086A
249	24873	13747	6129	35B3
250	22071	27646	5637	6BFE

... continued on next page

PN Offset Programming Information – continued

Table B-1: PnMask I and PnMask Q Values for PilotPn				
14-Chip Delay				
Pilot PN	I (Dec.)	Q	I (Hex.)	Q
251	13904	1056	3650	0420
252	27198	1413	6A3E	0585
253	3685	3311	0E65	0CEF
254	16820	4951	41B4	1357
255	22479	749	57CF	02ED
256	6850	6307	1AC2	18A3
257	15434	961	3C4A	03C1
258	19332	2358	4B84	0936
259	8518	28350	2146	6EBE
260	14698	31198	396A	79DE
261	21476	11467	53E4	2CCB
262	30475	8862	770B	229E
263	23984	6327	5DB0	18B7
264	1912	7443	0778	1D13
265	26735	28574	686F	6F9E
266	15705	25093	3D59	6205
267	3881	6139	0F29	17FB
268	20434	22047	4FD2	561F
269	16779	32545	418B	7F21
270	31413	7112	7AB5	1BC8
271	16860	28535	41DC	6F77
272	8322	10378	2082	288A
273	28530	15065	6F72	3AD9
274	26934	5125	6936	1405
275	18806	12528	4976	30F0
276	20216	23215	4EF8	5AAF
277	9245	20959	241D	51DF
278	8271	3568	204F	0DF0
279	18684	26453	48FC	6755
280	8220	29421	201C	72ED
281	6837	24555	1AB5	5FEB
282	9613	10779	258D	2A1B
283	31632	25260	7B90	62AC
284	27448	16084	6B38	3ED4
285	12417	26028	3081	65AC
286	30901	29852	78B5	749C
287	9366	14978	2496	3A82
288	12225	12182	2FC1	2F96
289	21458	25143	53D2	6237
290	6466	15838	1942	3DDE
291	8999	5336	2327	14D8
292	26718	21885	685E	557D
293	3230	20561	0C9E	5051
294	27961	30097	6D39	7591
295	28465	21877	6F31	5575
296	6791	23589	1A87	5C25
297	17338	26060	43BA	65CC
298	11832	9964	2E38	26EC
299	11407	25959	2C8F	6567
300	15553	3294	3CC1	0CDE

... continued on next page



PN Offset Programming Information – continued

B

Table B-1: PnMask I and PnMask Q Values for PilotPn				
14-Chip Delay				
Pilot PN	I (Dec.)	Q	I (Hex.)	Q
301	17418	30173	440A	75DD
302	14952	15515	3A68	3C9B
303	52	5371	0034	14FB
304	27254	10242	6A76	2802
305	15064	28052	3AD8	6D94
306	10942	14714	2ABE	397A
307	377	19550	0179	4C5E
308	14303	8866	37DF	22A2
309	24427	15297	5F6B	3BC1
310	26629	10898	6805	2A92
311	20011	31315	4E2B	7A53
312	16086	19475	3ED6	4C13
313	24374	1278	5F36	04FE
314	9969	11431	26F1	2CA7
315	29364	31392	72B4	7AA0
316	25560	4381	63D8	111D
317	28281	14898	6E79	3A32
318	7327	23959	1C9F	5D97
319	32449	16091	7EC1	3EDB
320	26334	9037	66DE	234D
321	14760	24162	39A8	5E62
322	15128	6383	3B18	18EF
323	29912	27183	74D8	6A2F
324	4244	16872	1094	41E8
325	8499	9072	2133	2370
326	9362	12966	2492	32A6
327	10175	28886	27BF	70D6
328	30957	25118	78ED	621E
329	12755	20424	31D3	4FC8
330	19350	6729	4B96	1A49
331	1153	20983	0481	51F7
332	29304	12372	7278	3054
333	6041	13948	1799	367C
334	21668	27547	54A4	6B9B
335	28048	8152	6D90	1FD8
336	10096	17354	2770	43CA
337	23388	17835	5B5C	45AB
338	15542	14378	3CB6	382A
339	24013	7453	5DCD	1D1D
340	2684	26317	0A7C	66CD
341	19018	5955	4A4A	1743
342	25501	10346	639D	286A
343	4489	13200	1189	3390
344	31011	30402	7923	76C2
345	29448	7311	7308	1C8F
346	25461	3082	6375	0C0A
347	11846	21398	2E46	5396
348	30331	31104	767B	7980
349	10588	24272	295C	5ED0
350	32154	27123	7D9A	69F3

... continued on next page

PN Offset Programming Information – continued

Table B-1: PnMask I and PnMask Q Values for PilotPn				
14-Chip Delay				
Pilot PN	I (Dec.)	Q	I (Hex.)	Q
351	29572	5578	7384	15CA
352	13173	25731	3375	6483
353	10735	10662	29EF	29A6
354	224	11084	00E0	2B4C
355	12083	31098	2F33	797A
356	22822	16408	5926	4018
357	2934	6362	0B76	18DA
358	27692	2719	6C2C	0A9F
359	10205	14732	27DD	398C
360	7011	22744	1B63	58D8
361	22098	1476	5652	05C4
362	2640	8445	0A50	20FD
363	4408	21118	1138	527E
364	102	22198	0066	56B6
365	27632	22030	6BF0	560E
366	19646	10363	4CBE	287B
367	26967	25802	6957	64CA
368	32008	2496	7D08	09C0
369	7873	31288	1EC1	7A38
370	655	24248	028F	5EB8
371	25274	14327	62BA	37F7
372	16210	23154	3F52	5A72
373	11631	13394	2D6F	3452
374	8535	1806	2157	070E
375	19293	17179	4B5D	431B
376	12110	10856	2F4E	2A68
377	21538	25755	5422	649B
378	10579	15674	2953	3D3A
379	13032	7083	32E8	1BAB
380	14717	29096	397D	71A8
381	11666	3038	2D92	0BDE
382	25809	16277	64D1	3F95
383	5008	25525	1390	63B5
384	32418	20465	7EA2	4FF1
385	22175	28855	569F	70B7
386	11742	32732	2DDE	7FDC
387	22546	20373	5812	4F95
388	21413	9469	53A5	24FD
389	133	26155	0085	662B
390	4915	6957	1333	1B2D
391	8736	12214	2220	2FB6
392	1397	21479	0575	53E7
393	18024	31914	4668	7CAA
394	15532	32311	3CAC	7E37
395	26870	11276	68F6	2C0C
396	5904	20626	1710	5092
397	24341	423	5F15	01A7
398	13041	2679	32F1	0A77
399	23478	15537	5BB6	3CB1
400	1862	10818	0746	2A42

... continued on next page



PN Offset Programming Information – continued

B

Table B-1: PnMask I and PnMask Q Values for PilotPn				
14-Chip Delay				
Pilot PN	I (Dec.)	Q	I (Hex.)	Q
401	5850	23074	16DA	5A22
402	5552	20250	15B0	4F1A
403	12589	14629	312D	3925
404	23008	29175	59E0	71F7
405	27636	13943	6BF4	3677
406	17600	11072	44C0	2B40
407	17000	29492	4268	7334
408	21913	5719	5599	1657
409	30320	7347	7670	1CB3
410	28240	12156	6E50	2F7C
411	7260	25623	1C5C	6417
412	17906	27725	45F2	6C4D
413	5882	28870	16FA	70C6
414	22080	31478	5640	7AF6
415	12183	28530	2F97	6F72
416	23082	24834	5A2A	6102
417	17435	9075	441B	2373
418	18527	32265	485F	7E09
419	31902	3175	7C9E	0C67
420	18783	17434	495F	441A
421	20027	12178	4E3B	2F92
422	7982	25613	1F2E	640D
423	20587	31692	506B	7BCC
424	10004	25384	2714	6328
425	13459	18908	3493	49DC
426	13383	25816	3447	64D8
427	28930	4661	7102	1235
428	4860	31115	12FC	798B
429	13108	7691	3334	1E0B
430	24161	1311	5E61	051F
431	20067	16471	4E63	4057
432	2667	15771	0A6B	3D9B
433	13372	16112	343C	3EF0
434	28743	21062	7047	5246
435	24489	29690	5FA9	73FA
436	249	10141	00F9	279D
437	19960	19014	4DF8	4A46
438	29682	22141	73F2	567D
439	31101	11852	797D	2E4C
440	27148	26404	6A0C	6724
441	26706	30663	6852	77C7
442	5148	32524	141C	7FOC
443	4216	28644	1078	6FE4
444	5762	10228	1682	27F4
445	245	23536	00F5	5BF0
446	21882	18045	557A	467D
447	3763	25441	0EB3	6361
448	206	27066	00CE	69BA
449	28798	13740	707E	35AC
450	32402	13815	7E92	35F7

... continued on next page

PN Offset Programming Information – continued

Table B-1: PnMask I and PnMask Q Values for PilotPn				
14-Chip Delay				
Pilot PN	I (Dec.)	Q	I (Hex.)	Q
451	13463	3684	3497	0E64
452	15417	23715	3C39	5CA3
453	23101	15314	5A3D	3BD2
454	14957	32469	3A6D	7ED5
455	23429	9816	5B85	2658
456	12990	4444	32BE	115C
457	12421	5664	3085	1620
458	28875	7358	70CB	1CBE
459	4009	27264	0FA9	6A80
460	1872	28128	0750	6DE0
461	15203	30168	3B63	75D8
462	30109	29971	759D	7513
463	24001	3409	5DC1	0D51
464	4862	16910	12FE	420E
465	14091	20739	370B	5103
466	6702	10191	1A2E	27CF
467	3067	12819	0BFB	3213
468	28643	19295	6FE3	4B5F
469	21379	10072	5383	2758
470	20276	15191	4F34	3B57
471	25337	27748	62F9	6C64
472	19683	720	4CE3	02D0
473	10147	29799	27A3	7467
474	16791	27640	4197	6BF8
475	17359	263	43CF	0107
476	13248	24734	33C0	609E
477	22740	16615	58D4	40E7
478	13095	20378	3327	4F9A
479	10345	25116	2869	621C
480	30342	19669	7686	4CD5
481	27866	14656	6CDA	3940
482	9559	27151	2557	6A0F
483	8808	28728	2268	7038
484	12744	25092	31C8	6204
485	11618	22601	2D62	5849
486	27162	2471	6A1A	09A7
487	17899	25309	45EB	62DD
488	29745	15358	7431	3BFE
489	31892	17739	7C94	454B
490	23964	12643	5D9C	3163
491	23562	32730	5C0A	7FDA
492	2964	19122	0B94	4AB2
493	18208	16870	4720	41E6
494	15028	10787	3AB4	2A23
495	21901	18400	558D	47E0
496	24566	20295	5FF6	4F47
497	18994	1937	4A32	0791
498	13608	17963	3528	462B
499	27492	7438	6B64	1D0E
500	11706	12938	2DBA	328A

... continued on next page



B

Table B-1: PnMask I and PnMask Q Values for PilotPn				
14-Chip Delay				
Pilot PN	I (Dec.)	Q (Dec.)	I (Hex.)	Q (Hex.)
501	14301	19272	37DD	4B48
502	23380	29989	5B54	7525
503	11338	8526	2C4A	214E
504	2995	18139	0BB3	46DB
505	23390	3247	5B5E	0CAF
506	14473	28919	3889	70F7
507	6530	7292	1982	1C7C
508	20452	20740	4FE4	5104
509	12226	27994	2FC2	6D5A
510	1058	2224	0422	08B0
511	12026	6827	2EFA	1AAB

Appendix C: FRU Optimization/ATP Test Matrix

Appendix Content

Appendix C: FRU Optimization/ATP Test Matrix	C-1
Usage & Background	C-1
Detailed Optimization/ATP Test Matrix	C-2



FRU Optimization/ATP Test Matrix

Usage & Background

Periodic maintenance of a site may also may mandate re-optimization of specific portions of the site. An outline of some basic guidelines is included in the following tables.



IMPORTANT

Re-optimization steps listed for any assembly detailed in the tables below must be performed *anytime* an RF cable associated with it is replaced.



BTS Frame

Table C-1: When RF Optimization Is required on the BTS	
Item Replaced	Optimize:
C-CCP Shelf	All sector TX and RX paths to all Combined CDMA Channel Processor (C-CCP) shelves.
Multicoupler/Preselector Card	The three or six affected sector RX paths for the C-CCP shelf in the BTS frames.
Preselector I/O	All sector RX paths.
BBX board	RX and TX paths of the affected C-CCP shelf / BBX board.
CIO Card	All RX and TX paths of the affected CDMA carrier.
Any LPA Module	The affected sector TX path.
LPA Backplane	The affected sector TX path.
LPA Filter	The affected sector TX path.

Ancillary Frame

Item Replaced	Optimize:
Directional Coupler	All affected sector RX and TX paths to all BTS frame shelves.
Site filter	All affected RX sector paths in all shelves in all BTS frames.
Any RFDS component or TSU.	The RFDS calibration RX & TX paths (MONFWD/GENFWD).

. . . continued on next page

C

Inter-frame Cabling

Optimization must be performed after the replacement of any RF cabling between BTS frames.

Item Replaced	Optimize:
Ancillary frame to BTS frame (RX) cables	The affected sector/antenna RX paths.
BTS frame to ancillary frame (TX) cables	The affected sector/antenna TX paths.

Detailed Optimization/ATP Test Matrix

Table C-3 outlines in more detail the tests that would need to be performed if one of the BTS components were to fail and be replaced. It is also assumed that all modules are placed OOS-ROM via the LMF until full redundancy of all applicable modules is implemented.

The following guidelines should also be noted when using this table.



IMPORTANT

Not every procedure required to bring the site back on line is indicated in Table C-3. It is meant to be used as a guideline ONLY. The table assumes that the user is familiar enough with the BTS Optimization/ATP procedure to understand which test equipment set ups, calibrations, and BTS site preparation will be required before performing the Table # procedures referenced.

Various passive BTS components (such as the TX and RX directional couplers, Preselector IO, CIO; etc.) only call for a TX or RX calibration audit to be performed in lieu of a full path calibration. If the RX or TX path calibration audit fails, the entire RF path calibration will need to be repeated. If the RF path calibration fails, further troubleshooting is warranted.

Whenever any C-CCP BACKPLANE is replaced, it is assumed that only power to the C-CCP shelf being replaced is turned off via the breaker supplying that shelf.

Whenever any DISTRIBUTION BACKPLANE is replaced it is assumed that the power to the entire RFM frame is removed and the Preselector I/O is replaced. The modem frame should be brought up as if it were a new installation.

. . . continued on next page

NOTE

If any significant change in signal level results from any component being replaced in the RX or TX signal flow paths, it would be identified by re-running the RX and TX calibration audit command.

When the CIO is replaced, the C-CCP shelf remains powered up. The BBX boards may need to be removed, then re-installed into their original slots, and re-downloaded (code and BLO data). RX and TX calibration audits should then be performed.

. . . continued on next page



FRU Optimization/ATP Test Matrix – continued

Table C-3: SC 4812T BTS Optimization and ATP Test Matrix

Doc Tbl #	page	Description	Directional Coupler (RX)	Directional Coupler (TX)	RX Filter	RX Cables	TX Cables	Multicoupler/Preselector	CIO	C-CCP Backplane	BBX2	MCC24/MCC8E	CSM	LFR/HSO	GPS	GLI2	LPA	LPA Filter Bandpass	Power Converters (See Note)	SWITCH CARD	LPA Combiner Filter 2:1	LPA Combiner Filter 4:1	LPA Backplane
Table 2-1	2-2	Initial Boards/Modules Install, Preliminary Operations, CDF Site Equipage; etc.	•	•	•	•	•	•	•	•	•	•	•	•	•	•	•	•	•	•	•	•	•
Table 2-2	2-5	DC Power Pre-Test			•					•													
Table 2-5	2-13	Physical Inspect																					
Table 2-7	2-14	Initial Power-up			•					•													
Table 3-6	3-15	Ping the Processors								•	•	•	•				•			•			
Table 3-12	3-28	Download/Enable MGLI2s								•							•						
Table 3-12	3-28	Download/Enable GLIs								•							•						
Table 3-13	3-29	Download CSMs								•			•		•								
Table 3-13	3-29	Download MCCs,								•			•		•								
Table 3-13	3-29	Download BBXs								•	•												
Table 3-15	3-31	Enable CSMs								•			•										
Table 3-16	3-32	Enable MCCs								•		•											
Table 3-19	3-37	GPS Initialization / Verification								•			•		•								
Table 3-20	3-41	LFR Initialization / Verification								•				•									
Table 3-21	3-43	HSO Initialization/Verification								•				•									
Table 3-34	3-70	TX Path Calibration								•	•										•		
Table 3-35	3-71	Download Offsets to BBX						•		•	•												
Table 3-36	3-73	TX Path Calibration Audit	•			•		•	•	•							•	•		•	•	•	•
Table 4-1	4-3	Spectral Purity TX Mask ATP								•	•						•	•		•	•	•	•
Table 4-1	4-3	Waveform Quality (rho) ATP							•	•	•		•		•		•	•			•	•	•
Table 4-1	4-3	Pilot Time Offset ATP							•	•	•		•		•		•	•			•	•	•
Table 4-1	4-3	Code Domain Power / Noise Floor								•	•	•											
Table 4-1	4-3	FER Test						•	•	•	•	•											

NOTE

Replace power converters one card at a time so that power to the C-CCP or LPA shelf is not lost. If power to the C-CCP shelf is lost, all cards in the shelf must be downloaded again.

Appendix D: BBX Gain Set Point vs. BTS Output Considerations

Appendix Content

Appendix D: BBX Gain Set Point vs. BTS Output Considerations	D-1
Usage & Background	D-1



BBX Gain Set Point vs. BTS Output Considerations

Usage & Background

Table D-1 outlines the relationship between the *total* of all code domain channel element gain settings (digital root sum of the squares) and the BBX Gain Set Point between 33.0 dBm and 44.0 dBm. The resultant RF output (as measured at the top of the BTS in dBm) is shown in the table. The table assumes that the BBX Bay Level Offset (BLO) values have been calculated.

As an illustration, consider a BBX keyed up to produce a CDMA carrier with only the Pilot channel (no MCCs forward link enabled). Pilot gain is set to 262. In this case, the BBX Gain Set Point is shown to correlate exactly to the actual RF output anywhere in the 33 to 44 dBm output range. (This is the level used to calibrate the BTS).

Table D-1: BBX Gain Set Point vs. Actual BTS Output (in dBm)

dBm↗ Gain↘	44	43	42	41	40	39	38	37	36	35	34	33
541	–	–	–	–	–	–	–	43.3	42.3	41.3	40.3	39.3
533	–	–	–	–	–	–	–	43.2	42.2	41.2	40.2	39.2
525	–	–	–	–	–	–	44	43	42	41	40	39
517	–	–	–	–	–	–	43.9	42.9	41.9	40.9	39.9	38.9
509	–	–	–	–	–	–	43.8	42.8	41.8	40.8	39.8	38.8
501	–	–	–	–	–	–	43.6	42.6	41.6	40.6	39.6	38.6
493	–	–	–	–	–	–	43.5	42.5	41.5	40.5	39.5	38.5
485	–	–	–	–	–	–	43.4	42.4	41.4	40.4	39.4	38.4
477	–	–	–	–	–	–	43.2	42.2	41.2	40.2	39.2	38.2
469	–	–	–	–	–	–	43.1	42.1	41.1	40.1	39.1	38.1
461	–	–	–	–	–	43.9	42.9	41.9	40.9	39.9	38.9	37.9
453	–	–	–	–	–	43.8	42.8	41.8	40.8	39.8	38.8	37.8
445	–	–	–	–	–	43.6	42.6	41.6	40.6	39.6	38.6	37.6
437	–	–	–	–	–	43.4	42.4	41.4	40.4	39.4	38.4	37.4
429	–	–	–	–	–	43.3	42.3	41.3	40.3	39.3	38.3	37.3
421	–	–	–	–	–	43.1	42.1	41.1	40.1	39.1	38.1	37.1
413	–	–	–	–	44	43	42	41	40	39	38	37
405	–	–	–	–	43.8	42.8	41.8	40.8	39.8	38.8	37.8	36.8
397	–	–	–	–	43.6	42.6	41.6	40.6	39.6	38.6	37.6	36.6
389	–	–	–	–	43.4	42.4	41.4	40.4	39.4	38.4	37.4	36.4

... continued on next page



BBX Gain Set Point vs. BTS Output Considerations – continued

Table D-1: BBX Gain Set Point vs. Actual BTS Output (in dBm)

dBm↗ Gain↘	44	43	42	41	40	39	38	37	36	35	34	33
381	–	–	–	–	43.3	42.3	41.3	40.3	39.3	38.3	37.3	36.3
374	–	–	–	–	43.1	42.1	41.1	40.1	39.1	38.1	37.1	36.1
366	–	–	–	43.9	42.9	41.9	40.9	39.9	38.9	37.9	36.9	35.9
358	–	–	–	43.7	42.7	41.7	40.7	39.7	38.7	37.7	36.7	35.7
350	–	–	–	43.5	42.5	41.5	40.5	39.5	38.5	37.5	36.5	35.5
342	–	–	–	43.3	42.3	41.3	40.3	39.3	38.3	37.3	36.3	35.3
334	–	–	–	43.1	42.1	41.1	40.1	39.1	38.1	37.1	36.1	35.1
326	–	–	43.9	42.9	41.9	40.9	39.9	38.9	37.9	36.9	35.9	34.9
318	–	–	43.7	42.7	41.7	40.7	39.7	38.7	37.7	36.7	35.7	34.7
310	–	–	43.5	42.5	41.5	40.5	39.5	38.5	37.5	36.5	35.5	34.5
302	–	–	43.2	42.2	41.2	40.2	39.2	38.2	37.2	36.2	35.2	34.2
294	–	44	43	42	41	40	39	38	37	36	35	34
286	–	43.8	42.8	41.8	40.8	39.8	38.8	37.8	36.8	35.8	34.8	33.8
278	–	43.5	42.5	41.5	40.5	39.5	38.5	37.5	36.5	35.5	34.5	33.5
270	–	43.3	42.3	41.3	40.3	39.3	38.3	37.3	36.3	35.3	34.3	33.3
262	44	43	42	41	40	39	38	37	36	35	34	33
254	43.7	42.7	41.7	40.7	39.7	38.7	37.7	36.7	35.7	34.7	33.7	–
246	43.4	42.4	41.4	40.4	39.4	38.4	37.4	36.4	35.4	34.4	33.4	–
238	43.2	42.2	41.2	40.2	39.2	38.2	37.2	36.2	35.2	34.2	33.2	–
230	42.9	41.9	40.9	39.9	38.9	37.9	36.9	35.9	34.9	33.9	–	–
222	42.6	41.6	40.6	39.6	38.6	37.6	36.6	35.6	34.6	33.6	–	–
214	42.2	41.2	40.2	39.2	38.2	37.2	36.2	35.2	34.2	33.2	–	–

Appendix E: CDMA Operating Frequency Information

Appendix Content

CDMA Operating Frequency Programming Information – North	
American PCS Bands	E-1
Introduction	E-1
1900 MHz PCS Channels	E-1
Calculating 1900 MHz Center Frequencies	E-2
800 MHz CDMA Channels	E-4
Calculating 800 MHz Center Frequencies	E-4
CDMA Operating Frequency Programming Information – Korean Bands	E-6
1700 MHz PCS Channels	E-6
Calculating 1700 MHz Center Frequencies	E-7



CDMA Operating Frequency Programming Information – North American PCS Bands

Introduction

Programming of each of the BTS BBX synthesizers is performed by the BTS GLIs via the CHI bus. This programming data determines the transmit and receive transceiver operating frequencies (channels) for each BBX.

1900 MHz PCS Channels

Figure E-1 shows the valid channels for the North American PCS 1900 MHz frequency spectrum. There are 10 CDMA wireline or non-wireline band channels used in a CDMA system (unique per customer operating system).

Figure E-1: North American PCS 1900 MHz Frequency Spectrum (CDMA Allocation)

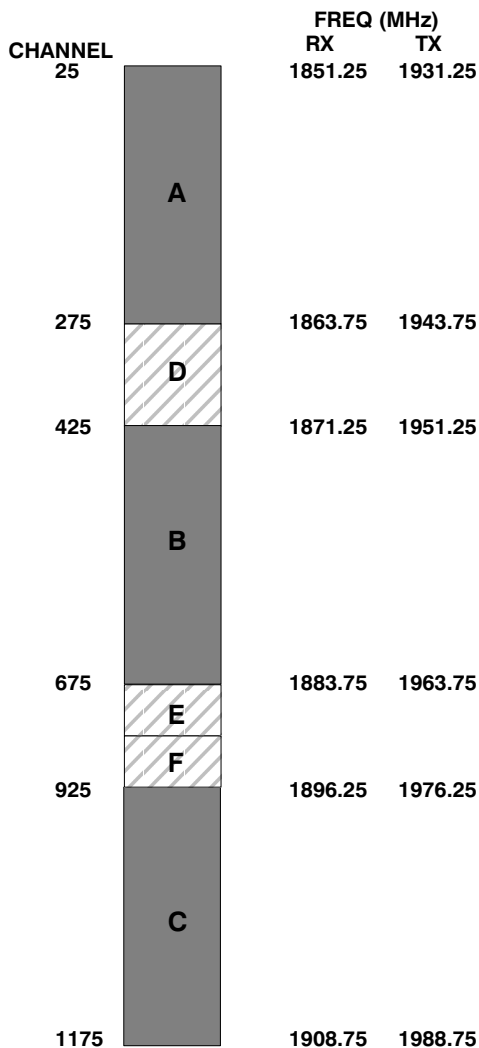

... continued on next page

CDMA Operating Frequency Programming Information – North American Bands – continued

Calculating 1900 MHz Center Frequencies

Table E-1 shows selected 1900 MHz CDMA candidate operating channels, listed in both decimal and hexadecimal, and the corresponding transmit, and receive frequencies. Center frequencies (in MHz) for channels not shown in the table may be calculated as follows:

- $TX = 1930 + 0.05 * \text{Channel\#}$
Example: Channel 262
 $TX = 1930 + 0.05 * 262 = 1943.10 \text{ MHz}$
- $RX = TX - 80$
Example: Channel 262
 $RX = 1943.10 - 80 = 1863.10 \text{ MHz}$

Actual frequencies used depend on customer CDMA system frequency plan.

Each CDMA channel requires a 1.77 MHz frequency segment. The actual CDMA carrier is 1.23 MHz wide, with a 0.27 MHz guard band on both sides of the carrier.

Minimum frequency separation required between any CDMA carrier and the nearest NAMPS/AMPS carrier is 900 kHz (center-to-center).

Table E-1: 1900 MHz TX and RX Frequency vs. Channel

Channel Number		Transmit Frequency (MHz) Center Frequency	Receive Frequency (MHz) Center Frequency
Decimal	Hex		
25	0019	1931.25	1851.25
50	0032	1932.50	1852.50
75	004B	1933.75	1853.75
100	0064	1935.00	1855.00
125	007D	1936.25	1856.25
150	0096	1937.50	1857.50
175	00AF	1938.75	1858.75
200	00C8	1940.00	1860.00
225	00E1	1941.25	1861.25
250	00FA	1942.50	1862.50
275	0113	1943.75	1863.75
300	012C	1945.00	1865.00
325	0145	1946.25	1866.25
350	015E	1947.50	1867.50
375	0177	1948.75	1868.75
400	0190	1950.00	1870.00
425	01A9	1951.25	1871.25
450	01C2	1952.50	1872.50
475	01DB	1953.75	1873.75
500	01F4	1955.00	1875.00

... continued on next page

CDMA Operating Frequency Programming Information – North American Bands – continued

Table E-1: 1900 MHz TX and RX Frequency vs. Channel

Channel Number Decimal	Hex	Transmit Frequency (MHz) Center Frequency	Receive Frequency (MHz) Center Frequency
525	020D	1956.25	1876.25
550	0226	1957.50	1877.50
575	023F	1958.75	1878.75
600	0258	1960.00	1880.00
625	0271	1961.25	1881.25
650	028A	1962.50	1882.50
675	02A3	1963.75	1883.75
700	02BC	1965.00	1885.00
725	02D5	1966.25	1886.25
750	02EE	1967.50	1887.50
775	0307	1968.75	1888.75
800	0320	1970.00	1890.00
825	0339	1971.25	1891.25
850	0352	1972.50	1892.50
875	036B	1973.75	1893.75
900	0384	1975.00	1895.00
925	039D	1976.25	1896.25
950	03B6	1977.50	1897.50
975	03CF	1978.75	1898.75
1000	03E8	1980.00	1900.00
1025	0401	1981.25	1901.25
1050	041A	1982.50	1902.50
1075	0433	1983.75	1903.75
1100	044C	1985.00	1905.00
1125	0465	1986.25	1906.25
1150	047E	1987.50	1807.50
1175	0497	1988.75	1908.75

■
E
■

CDMA Operating Frequency Programming Information – North American Bands – continued

800 MHz CDMA Channels

Figure E-2 shows the valid channels for the North American cellular telephone frequency spectrum. There are 10 CDMA wireline or non-wireline band channels used in a CDMA system (unique per customer operating system).

Figure E-2: North American Cellular Telephone System Frequency Spectrum (CDMA Allocation)

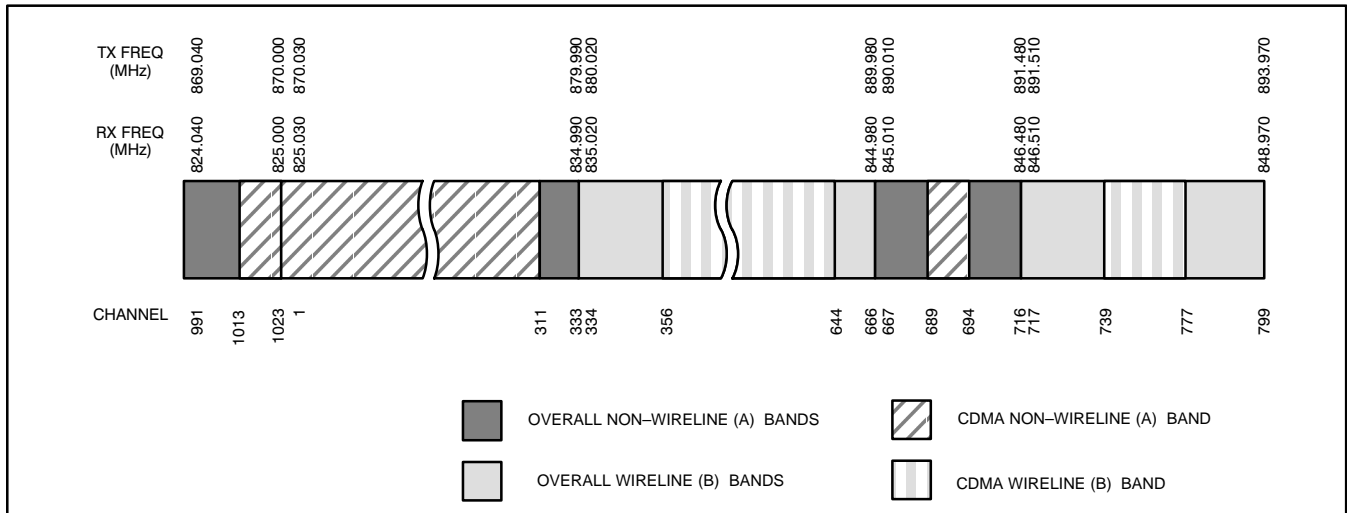

FW00402

Calculating 800 MHz Center Frequencies

Table E-2 shows selected 800 MHz CDMA candidate operating channels, listed in both decimal and hexadecimal, and the corresponding transmit, and receive frequencies. Center frequencies (in MHz) for channels not shown in the table may be calculated as follows:

- Channels 1–777
 $TX = 870 + 0.03 * \text{Channel\#}$
Example: Channel 262
 $TX = 870 + 0.03 * 262 = 877.86 \text{ MHz}$
- Channels 1013–1023
 $TX = 870 + 0.03 * (\text{Channel\#} - 1023)$
Example: Channel 1015
 $TX = 870 + 0.03 * (1015 - 1023) = 869.76 \text{ MHz}$
- $RX = TX - 45 \text{ MHz}$
Example: Channel 262
 $RX = 877.86 - 45 = 832.86 \text{ MHz}$

Table E-2: 800 MHz TX and RX Frequency vs. Channel

Channel Number		Transmit Frequency (MHz) Center Frequency	Receive Frequency (MHz) Center Frequency
Decimal	Hex		
1	0001	870.0300	825.0300
25	0019	870.7500	825.7500

... continued on next page

CDMA Operating Frequency Programming Information – North American Bands – continued

Table E-2: 800 MHz TX and RX Frequency vs. Channel

Channel Number		Transmit Frequency (MHz) Center Frequency	Receive Frequency (MHz) Center Frequency
Decimal	Hex		
50	0032	871.5000	826.5000
75	004B	872.2500	827.2500
100	0064	873.0000	828.0000
125	007D	873.7500	828.7500
150	0096	874.5000	829.5000
175	00AF	875.2500	830.2500
200	00C8	876.0000	831.0000
225	00E1	876.7500	831.7500
250	00FA	877.5000	832.5000
275	0113	878.2500	833.2500
300	012C	879.0000	834.0000
325	0145	879.7500	834.7500
350	015E	880.5000	835.5000
375	0177	881.2500	836.2500
400	0190	882.0000	837.0000
425	01A9	882.7500	837.7500
450	01C2	883.5000	838.5000
475	01DB	884.2500	839.2500
500	01F4	885.0000	840.0000
525	020D	885.7500	840.7500
550	0226	886.5000	841.5000
575	023F	887.2500	842.2500
600	0258	888.0000	843.0000
625	0271	888.7500	843.7500
650	028A	889.5000	844.5000
675	02A3	890.2500	845.2500
700	02BC	891.0000	846.0000
725	02D5	891.7500	846.7500
750	02EE	892.5000	847.5000
775	0307	893.2500	848.2500
NOTE			
Channel numbers 778 through 1012 are not used.			
1013	03F5	869.7000	824.7000
1023	03FF	870.0000	825.0000



CDMA Operating Frequency Programming Information – Korean Bands

1700 MHz PCS Channels

Figure E-3 shows the valid channels for the 1700 MHz PCS frequency spectrum. The CDMA channels are spaced in increments of 25 (25, 50, 75, . . . 575) across the CDMA band.

Figure E-3: 1700 MHz PCS Frequency Spectrum (CDMA Allocation)

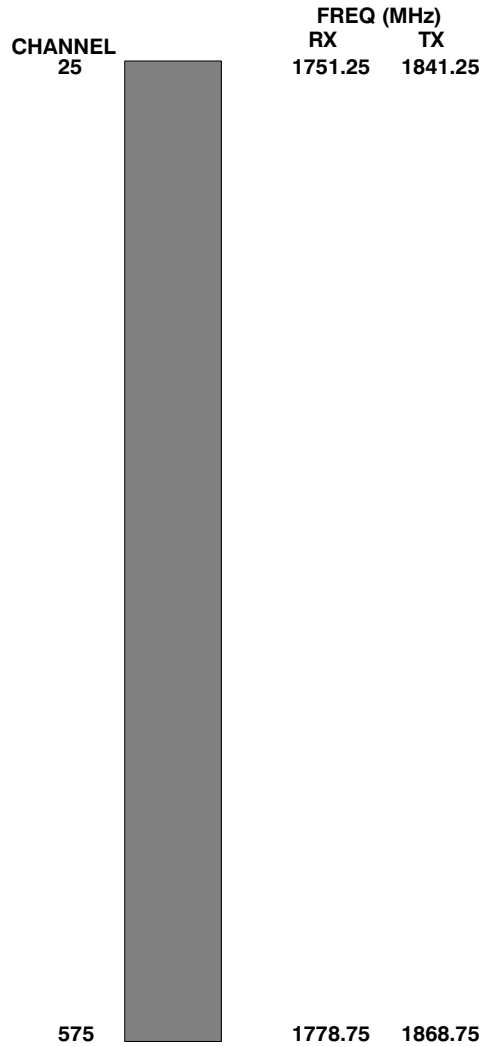

. . . continued on next page

CDMA Operating Frequency Programming Information – Korean Bands – continued

Calculating 1700 MHz Center Frequencies

Center frequency for channels may be calculated as follows:

Direction	Formula	Example
TX	$1840 + (0.05 * \text{Channel\#})$	Channel: $1840 + (0.05 * 25) = 1841.25$
RX	$1750 + (0.05 * \text{Channel\#})$	Channel: $1750 + (0.05 * 25) = 1751.25$

- Actual frequencies used depend on customer CDMA system frequency plan.
- Each CDMA channel requires a 1.77 MHz frequency segment. The actual CDMA carrier is 1.23 MHz wide, with a 0.27 MHz guard band on both sides of the carrier
- Minimum frequency separation required between any CDMA carrier and the nearest NAMPS/AMPS carrier is 900 kHz (center to center).

Channel Number		Transmit Frequency (MHz)	Receive Frequency (MHz)
Decimal	Hex	Center Frequency	Center Frequency
25	0019	1841.25	1751.25
50	0032	1842.50	1752.50
75	004B	1843.75	1753.75
100	0064	1845.00	1755.00
125	007D	1846.25	1756.25
150	0096	1847.50	1757.50
175	00AF	1848.75	1758.75
200	00C8	1850.00	1760.00
225	00E1	1851.25	1761.25
250	00FA	1852.50	1762.50
275	0113	1853.75	1763.75
300	012C	1855.00	1765.00
325	0145	1856.25	1766.25
350	015E	1857.50	1767.50
375	0177	1858.75	1768.75
400	0190	1860.00	1770.00
425	01A9	1861.25	1771.25
450	01C2	1862.50	1772.50
475	01DB	1863.75	1773.75
500	01F4	1865.00	1775.00
525	020D	1866.25	1776.25
550	0226	1867.50	1777.50
575	023F	1868.75	1778.75

E

Appendix F: PCS Interface Setup for Manual Testing

Appendix Content

Test Equipment Setup	F-1
Purpose	F-1
Equipment Warm up	F-1
Prerequisites	F-2
HP8921A System Connectivity Test	F-2
Manual Cable Calibration using HP8921 with HP PCS Interface (HP83236)	F-3
HP PCS Interface Test Equipment Setup for Manual Testing	F-7
Calibrating Test Cable Setup using Advantest R3465	F-8



Test Equipment Setup

Purpose

This section covers other test equipment and peripherals not covered in Chapter 3. Procedures for the manual testing are covered here, along with procedures to calibrate the TX and RX cables using the signal generator and spectrum analyzer.

Equipment Warm up



IMPORTANT

Warm-up BTS equipment for a minimum of *60 minutes* prior to performing the BTS optimization procedure. This assures BTS site stability and contributes to optimization accuracy. (Time spent running initial power-up, hardware/firmware audit, and BTS download counts as warm-up time.)



CAUTION

If any piece of test equipment (i.e., test cable, RF adapter) has been replaced, re-calibration must be performed. Failure to do so could introduce measurement errors, resulting in incorrect measurements and degradation to system performance.



IMPORTANT

Calibration of the communications test set (or equivalent test equipment) **must be** performed at the site before calibrating the overall test set. Calibrate the test equipment *after* it has been allowed to warm-up and stabilize for a *minimum of 60 minutes*.

■
F
■

Prerequisites

Prior to performing any of these procedures, all preparations for preparing the LMF, updating LMF files, and any other pre-calibration procedures, as stated in Chapter 3, must have been completed.

HP8921A System Connectivity Test

Follow the steps in Table F-1 to verify that the connections between the PCS Interface and the HP8921A are correct, and cables are intact. The software also performs basic functionality checks of each instrument.



IMPORTANT

Disconnect other GPIB devices, especially system controllers, from the system before running the connectivity software.

Table F-1: System Connectivity

Step	Action
	<p>* IMPORTANT</p> <ul style="list-style-type: none"> – Perform this procedure <i>after</i> test equipment has been allowed to warm-up and stabilize for a <i>minimum of 60 minutes</i>.
1	Insert HP 83236A Manual Control/System card into memory card slot.
2	Press the [PRESET] pushbutton.
3	Press the Screen Control [TESTS] pushbutton to display the “Tests” Main Menu screen.
4	Position the cursor at Select Procedure Location and select by pressing the cursor control knob. In the Choices selection box, select Card .
5	Position the cursor at Select Procedure Filename and select by pressing the cursor control knob. In the Choices selection box, select SYS_CONN .
6	Position the cursor at RUN TEST and select it. The software will prompt you through the connectivity setup.
7	When the test is complete, position the cursor on STOP TEST and select it; <i>OR</i> press the [K5] pushbutton.
8	To return to the main menu, press the [K5] pushbutton.

F

Test Equipment Setup – continued

Manual Cable Calibration using HP8921 with HP PCS Interface (HP83236)

Perform the procedure in Table F-2 to calibrate the test equipment using the HP8921 Cellular Communications Analyzer equipped with the HP83236 PCS Interface.

NOTE

This calibration method *must be executed with great care*. Some losses are measured close to the minimum limit of the power meter sensor (–30 dBm).

Prerequisites

Ensure the following prerequisites have been met before proceeding:

- Test equipment to be calibrated has been connected correctly for cable calibration.
- Test equipment has been selected and calibrated.

Refer to Figure F-1 for location of the components on the PCS Interface and Communications Test Set.

Table F-2: Manual Cable Calibration Test Equipment Setup (using the HP PCS Interface)

Step	Action		
	NOTE Verify that GPIB controller is turned off.		
1	Insert HP 83236A Manual Control System card into memory card slot (see Figure F-1).		
2	Press the Preset pushbutton.		
3	Under Screen Controls , press the TESTS pushbutton to display the TESTS (Main Menu) screen.		
4	Position the cursor at Select Procedure Location and select it. In the Choices selection box, select CARD .		
5	Position the cursor at Select Procedure Filename and select it. In the Choices selection box, select MANUAL .		
6	Position the cursor at RUN TEST and select it. HP must be in Control Mode Select YES .		
7	<table border="0"> <tr> <td style="vertical-align: top;"> <p>If using HP 83236A: Set channel number=<chan#>:</p> <ul style="list-style-type: none"> – Position cursor at Channel Number and select it. – Enter the <i>chan#</i> using the numeric keypad; press [Enter] and the screen will go blank. – When the screen reappears, the <i>chan#</i> will be displayed on the channel number line. </td> <td style="vertical-align: top;"> <p>If using HP 83236B: Set channel frequency:</p> <ul style="list-style-type: none"> – Position cursor at Frequency Band and press Enter. – Select User Defined Frequency. – Go Back to Previous Menu. – Position the cursor to 83236 generator frequency and enter actual RX frequency. – Position the cursor to 83236 analyzer frequency and enter actual TX frequency. </td> </tr> </table>	<p>If using HP 83236A: Set channel number=<chan#>:</p> <ul style="list-style-type: none"> – Position cursor at Channel Number and select it. – Enter the <i>chan#</i> using the numeric keypad; press [Enter] and the screen will go blank. – When the screen reappears, the <i>chan#</i> will be displayed on the channel number line. 	<p>If using HP 83236B: Set channel frequency:</p> <ul style="list-style-type: none"> – Position cursor at Frequency Band and press Enter. – Select User Defined Frequency. – Go Back to Previous Menu. – Position the cursor to 83236 generator frequency and enter actual RX frequency. – Position the cursor to 83236 analyzer frequency and enter actual TX frequency.
<p>If using HP 83236A: Set channel number=<chan#>:</p> <ul style="list-style-type: none"> – Position cursor at Channel Number and select it. – Enter the <i>chan#</i> using the numeric keypad; press [Enter] and the screen will go blank. – When the screen reappears, the <i>chan#</i> will be displayed on the channel number line. 	<p>If using HP 83236B: Set channel frequency:</p> <ul style="list-style-type: none"> – Position cursor at Frequency Band and press Enter. – Select User Defined Frequency. – Go Back to Previous Menu. – Position the cursor to 83236 generator frequency and enter actual RX frequency. – Position the cursor to 83236 analyzer frequency and enter actual TX frequency. 		

... continued on next page

Table F-2: Manual Cable Calibration Test Equipment Setup (using the HP PCS Interface)

Step	Action									
8	Set RF Generator level: <ul style="list-style-type: none"> – Position the cursor at RF Generator Level and select it. – Enter –10 using the numeric keypad; press [Enter] and the screen will go blank. – When the screen reappears, the value –10 dBm will be displayed on the RF Generator Level line. 									
9	Set the user fixed Attenuation Setting to 0 dBm : <ul style="list-style-type: none"> – Position cursor at Analyzer Attenuation and select it – Position cursor at User Fixed Atten Settings and select it. – Enter 0 (zero) using the numeric keypad and press [Enter]. 									
10	Select Back to Previous Menu .									
11	Record the HP83236 Generator Frequency Level: Record the HP83236 B Generator Frequency Level: <ul style="list-style-type: none"> – Position cursor at Show Frequency and Level Details and select it. – Under HP83236 Frequencies and Levels, record the Generator Level. – Under HP83236B Frequencies and Levels, record the Generator Frequency Level (1850 – 1910 MHz for 1.9 GHz or 1750 – 1780 for 1.7 GHz). – Position cursor at Prev Menu and select it. 									
12	Click on Pause for Manual Measurement .									
13	Connect the power sensor directly to the <i>RF OUT ONLY</i> port of the PCS Interface.									
14	On the HP8921A, under To Screen , select CDMA GEN .									
15	Move the cursor to the Amplitude field and click on the Amplitude value.									
16	Increase the Amplitude value until the power meter reads 0 dBm ±0.2 dB . NOTE The Amplitude value can be increased coarsely until 0 dBm is reached; then fine tune the amplitude by adjusting the Increment Set to 0.1 dBm and targeting in on 0 dBm.									
17	Disconnect the power sensor from the <i>RF OUT ONLY</i> port of the PCS Interface. * IMPORTANT The Power Meter sensor’s lower limit is –30 dBm. Thus, only components having losses ≤30 dB should be measured using this method. For further accuracy, always re-zero the power meter before connecting the power sensor to the component being calibrated. After connecting the power sensor to the component, record the calibrated loss immediately.									
18	Disconnect all components in the test setup and calibrate each one separately by connecting each component, one-at-a-time, between the <i>RF OUT ONLY PORT</i> and the power sensor (see Figure F-1, Setups A, B, or C). Record the calibrated loss value displayed on the power meter. <ul style="list-style-type: none"> • Example: <table style="margin-left: 20px;"> <tr> <td>(A) Test Cable(s)</td> <td>=</td> <td>–1.4 dB</td> </tr> <tr> <td>(B) 20 dB Attenuator</td> <td>=</td> <td>–20.1 dB</td> </tr> <tr> <td>(B) Directional Coupler</td> <td>=</td> <td>–29.8 dB</td> </tr> </table> 	(A) Test Cable(s)	=	–1.4 dB	(B) 20 dB Attenuator	=	–20.1 dB	(B) Directional Coupler	=	–29.8 dB
(A) Test Cable(s)	=	–1.4 dB								
(B) 20 dB Attenuator	=	–20.1 dB								
(B) Directional Coupler	=	–29.8 dB								

... continued on next page

Test Equipment Setup – continued

Table F-2: Manual Cable Calibration Test Equipment Setup (using the HP PCS Interface)

Step	Action
19	After all components are calibrated, reassemble all components together and calculate the total test setup loss by adding up all the individual losses: <ul style="list-style-type: none"> • Example: Total test setup loss = $-1.4 -29.8 -20.1 = -51.3$ dB. This calculated value will be used in the next series of tests.
20	Under Screen Controls press the TESTS button to display the TESTS (Main Menu) screen.
21	Select Continue (K2) .
22	Select RF Generator Level and set to -119 dBm.
23	Click on Pause for Manual Measurement .
24	Verify the HP8921A Communication Analyzer/83203A CDMA interface setup is as follows (fields not indicated remain at default): <ul style="list-style-type: none"> • Verify the GPIB (HP-IB) address: <ul style="list-style-type: none"> – under To Screen, select More – select IO CONFIG – Set HP-IB Adrs to 18 – set Mode to Talk&Lstn • Verify the HP8921A is displaying frequency (instead of RF channel) <ul style="list-style-type: none"> – Press the blue [SHIFT] button, then press the Screen Control [DUPLEX] button; this switches to the CONFIG (CONFIGURE) screen. – Use the cursor control to set RF Display to Freq
25	Refer to Table 3-29 for assistance in manually setting the cable loss values into the LMF.



Test Equipment Setup – continued

Figure F-1: Calibrating Test Setup Components

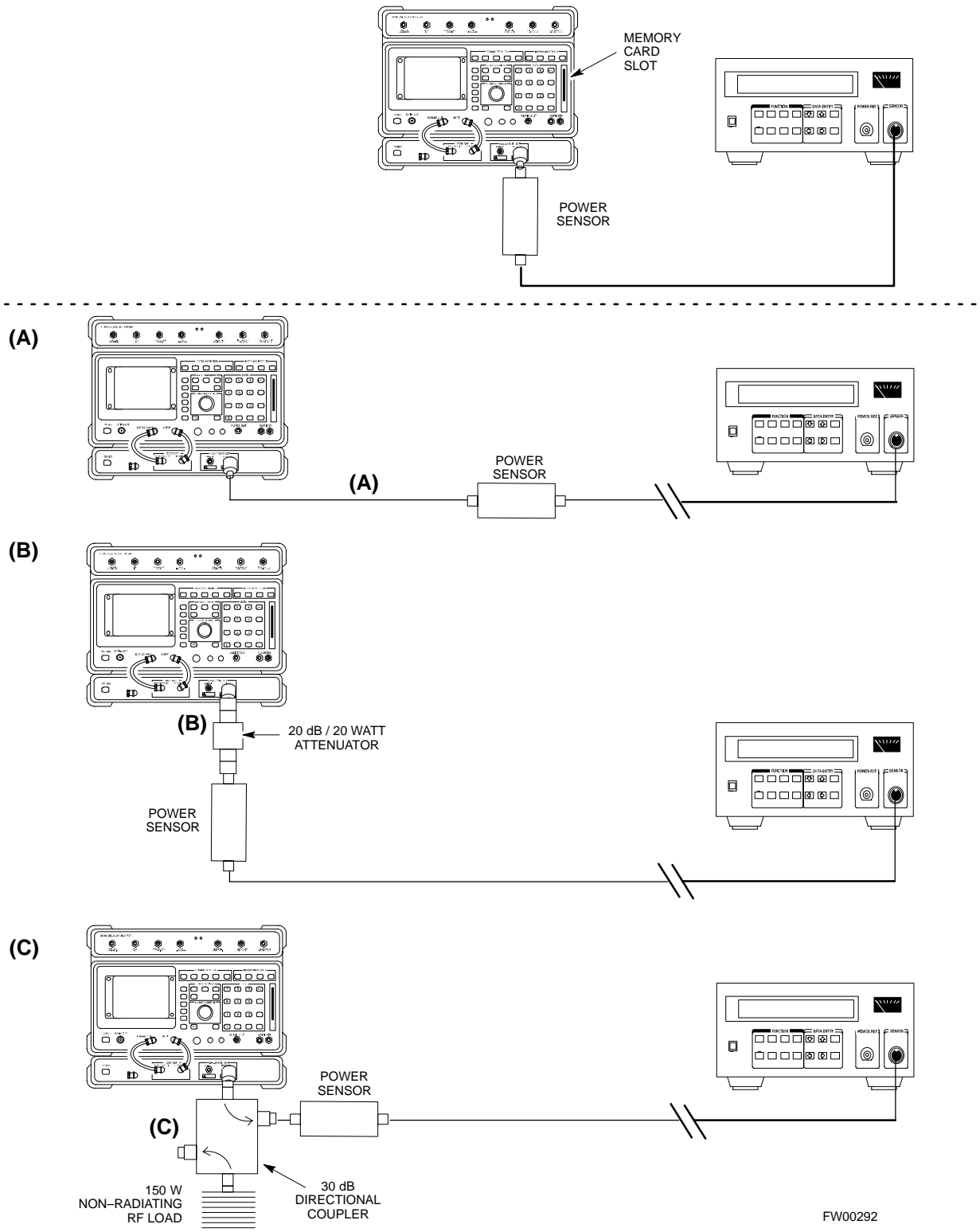

F

Test Equipment Setup – continued

HP PCS Interface Test Equipment Setup for Manual Testing

Follow the procedure in Table F-3 to setup the HP PCS Interface Box for manual testing.

Table F-3: HP PCS Interface Test Equipment Setup for Manual Testing		
✓	Step	Action
		NOTE Verify GPIB controller is turned off.
	1	Insert HP83236B Manual Control/System card into the memory card slot.
	2	Under Screen Controls , press the [TESTS] push-button to display the TESTS (Main Menu) screen.
	3	Position the cursor at Select Procedure Location and select. In the Choices selection box, select CARD .
	4	Position the cursor at Select Procedure Filename and select. In the Choices selection box, select MANUAL .
	5	Position the cursor at RUN TEST and select OR press the K1 push-button.
	6	Set channel number=<chan#>: <ul style="list-style-type: none"> – Position cursor at Channel Number and select. – Enter the <i>chan#</i> using the numeric keypad and then press [Enter] (the screen will blank). – When the screen reappears, the <i>chan#</i> will be displayed on the channel number line.
		* IMPORTANT If using a TMPC with Tower Top Amplifier (TTA) skip Step 7.
	7	<ul style="list-style-type: none"> • Set RF Generator level= $-119 \text{ dBm} + \text{Cal factor}$ Example: $-119 \text{ dBm} + 2 \text{ dB} = -117 \text{ dBm}$ • Continue with Step 9 (skip Step 8).
	8	Set RF Generator level= $-116 \text{ dBm} + \text{Cal factor}$. Example: $-116 \text{ dBm} + 2 \text{ dB} = -114 \text{ dBm}$
	9	Set the user fixed Attenuation Setting to 0 dB : <ul style="list-style-type: none"> – Position cursor at RF Generator Level and select. – Position cursor at User Fixed Atten Settings and select. – Enter 0 (zero) using the numeric keypad and press [Enter].
	10	Select Back to Previous Menu .
	11	Select Quit , then select Yes .

F

Test Equipment Setup – continued

Calibrating Test Cable Setup using Advantest R3465

NOTE

Be sure the GPIB Interface is OFF for this procedure.

Perform the procedure in Table F-4 to calibrate the test cable setup using the Advantest R3465. Advantest R3465 Manual Test setup and calibration must be performed at both the TX and RX frequencies.

Table F-4: Procedure for Calibrating Test Cable Setup Using Advantest R3465

Step	Action
	<p>* IMPORTANT</p> <ul style="list-style-type: none"> – This procedure can only be performed <i>after</i> test equipment has been allowed to warm-up and stabilize for a <i>minimum of 60 minutes</i>.
1	Press the SHIFT and the PRESET keys located below the display
2	Press the ADVANCE key in the MEASUREMENT area of the control panel.
3	Select the CDMA Sig CRT menu key
4	Select the Setup CRT menu key
5	Using the vernier knob and the cursor keys set the following parameters
	<p>NOTE</p> <p>Fields not listed remain at default</p> <p>Generator Mode: SIGNAL</p> <p>Link: FORWARD</p> <p>Level Unit: dBm</p> <p>CalCorrection: ON</p> <p>Level Offset: OFF</p>
6	Select the return CRT menu key
7	Press FREQ key in the ENTRY area
8	Set the frequency to the desired value using the keypad entry keys
9	Verify that the Mod CRT menu key is highlighting OFF; if not, press the Mod key to toggle it OFF.
10	Verify that the Output CRT menu key is highlighting OFF; if not, press the Output key to toggle it OFF.
11	Press the LEVEL key in the ENTRY area.
12	Set the LEVEL to 0 dBm using the key pad entry keys.
13	Zero power meter. Next connect the power sensor directly to the “RF OUT” port on the R3561L CDMA Test Source Unit.
14	Press the Output CRT menu key to toggle Output to ON.

... continued on next page

Test Equipment Setup – continued

Table F-4: Procedure for Calibrating Test Cable Setup Using Advantest R3465

Step	Action
15	Record the power meter reading _____
16	Disconnect the power meter sensor from the R3561L RF OUT jack. * IMPORTANT The Power Meter sensor’s lower limit is –30 dBm. Thus, only components having losses ≤ 30 dB should be measured using this method. For best accuracy, always re-zero the power meter before connecting the power sensor to the component being calibrated. Then, after connecting the power sensor to the component, record the calibrated loss immediately.
17	Disconnect all components in the the test setup and calibrate each one separately. Connect each component one–at–a–time between the “RF OUT” port and the power sensor (see Figure F-2, “Setups A, B, and C”). Record the calibrated loss value displayed on the power meter for each connection. Example: (A) 1st Test Cable = –0.5 dB (B) 2nd Test Cable = –1.4 dB (C) 20 dB Attenuator = –20.1 dB (D) 30 dB Directional Coupler = –29.8 dB
18	Press the Output CRT menu key to toggle Output OFF.
19	Calculate the total test setup loss by adding up all the individual losses: Example: Total test setup loss = 0.5 + 1.4 + 20.1 + 29.8 = 51.8 dB This calculated value will be used in the next series of tests.
20	Press the FREQ key in the ENTRY area
21	Using the keypad entry keys, set the test frequency to the RX frequency
22	Repeat steps 9 through 19 for the RX frequency.
23	Refer to Table 3-29 for assistance in manually setting the cable loss values into the LMF.



Test Equipment Setup – continued

Figure F-2: Cable Calibration using Advantest R3465

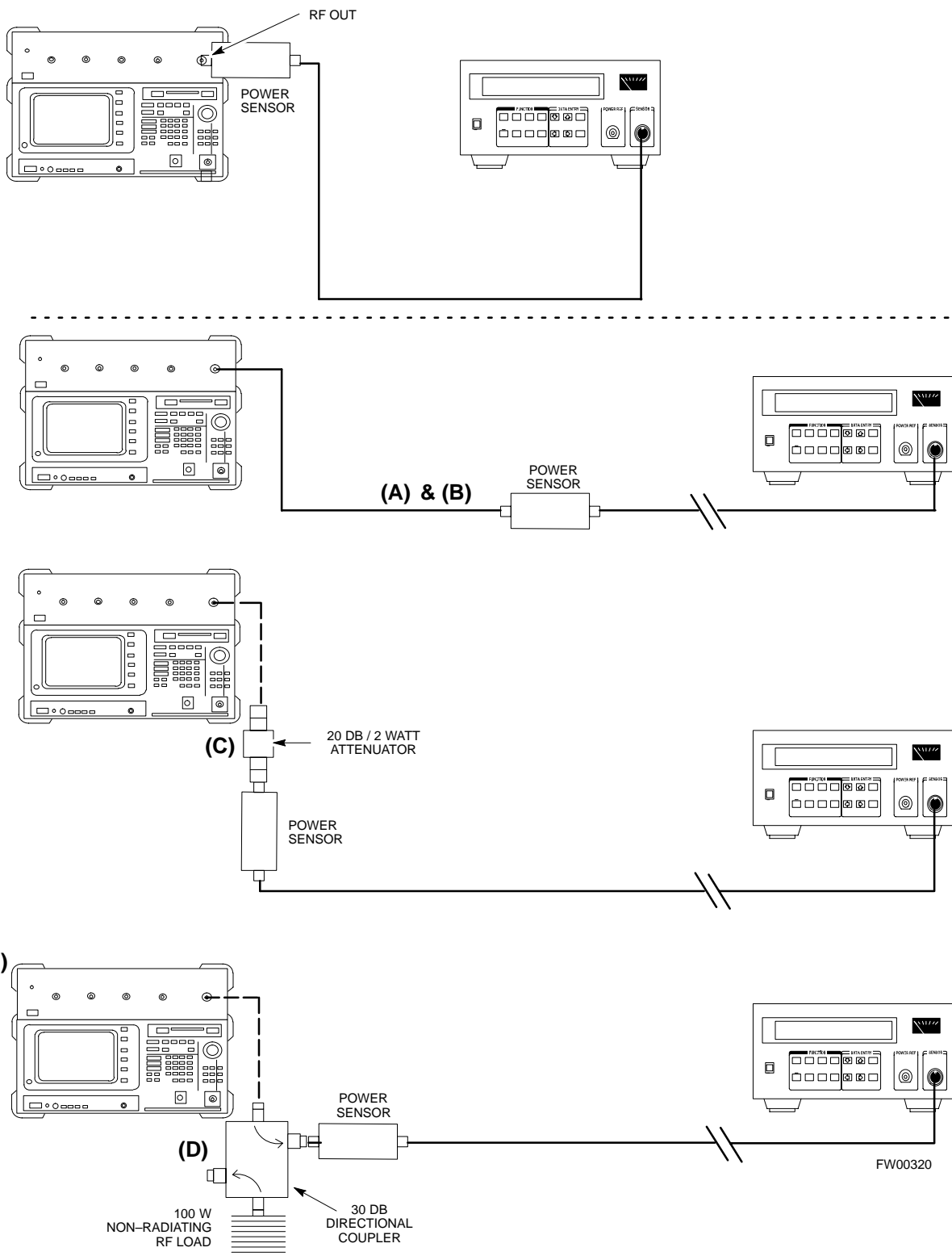

F

Appendix G: VSWR

Appendix Content

Transmit & Receive Antenna VSWR G-1
 Purpose G-1
 Test equipment G-1
 Equipment Setup – HP Test Set G-2
 Equipment Setup – Advantest Test Set G-4



Transmit & Receive Antenna VSWR

Purpose

The following procedures will verify that the Voltage Standing Wave Ratio (VSWR) of all antennas and associated feed lines fall within acceptable limits. The tests will be performed on all antennas in a sequential manner (i.e., ANT 1, then ANT 2) until all antennas/feedlines have been verified.

These procedures should be performed periodically by measuring each respective antenna's VSWR (reflected power) to verify that the antenna system is within acceptable limits. This will ensure continued peak system performance.

The antenna VSWR will be calculated at the CDMA carrier frequency assigned to each antenna. Record and verify that they meet the test specification of less than or equal to 1.5:1.



IMPORTANT

It is recommended that the installer be familiar with the following procedure in its entirety before beginning the actual procedure. Ensure that the entire site is currently not in service.

NOTE

This test is used to test RX antennas by substituting RX frequencies for TX frequencies.

*Study the site engineering documents and perform the following tests only after **first** verifying that the RF cabling configuration required to interconnect the BTS frames and antennas meet requirements called out in the *BTS Installation Manual*.*

G

Test equipment

The following pieces of test equipment will be required to perform this test:

- LMF
- Directional coupler
- Communications test set



WARNING

Prior to performing antenna tests, insure that no CDMA BBX channels are keyed. Failure to do so could result in personal injury or serious equipment damage.

Transmit & Receive Antenna VSWR – continued

Equipment Setup – HP Test Set

Follow the steps in Table G-1 to set up test equipment required to measure and calculate the VSWR for each antenna.

Table G-1: VSWR Measurement Procedure – HP Test Set		
Step	Action	HP TEST SET
1	<i>If you have not already done so</i> , refer to the procedure in Table 3-2 on page 3-5 to set up test equipment & interface the LMF computer to the BTS.	
2	<p><i>For manual VSWR testing</i>, using external directional coupler, refer to Figure G-1 (1700/1900 MHz) or Figure G-2 (800 MHz).</p> <ul style="list-style-type: none"> – Connect the communications test set RF OUT ONLY port to the INPUT port of the directional coupler. – Connect the RF IN/OUT port of the communication test set to the reverse (RVS) port on the directional coupler. <i>Terminate the forward port with a 50 ohm load.</i> – Install the antenna feed line to the output port on the directional coupler. 	
	<p>NOTE Manual Communications Analyzer test setup (fields not indicated remain at default):</p> <ul style="list-style-type: none"> • Set screen to RF GEN. <ul style="list-style-type: none"> – For 1900 MHz systems, set the RF Gen Freq to center frequency of actual CDMA carrier between 1930–1990 MHz for TX and 1850–1910 MHz for RX. For 800 MHz systems, set the RF Gen Freq to center frequency of actual CDMA carrier between 869–894 MHz for TX and 824–849 MHz for RX. For 1700 MHz systems, set the RF Gen Freq to center frequency of actual CDMA carrier between 1840–1870 MHz for TX and 1750–1780 MHz for RX. – Set Amplitude to –30 dBm. – Set Output Port to RF OUT. – Set AFGen1 & AFGen2 to OFF. 	
3	Remove the antenna feed line and install an “RF short” onto the directional coupler output port.	
	<p>NOTE Set-up communication test set as follows (fields not indicated remain at default):</p> <ul style="list-style-type: none"> • Set screen to SPEC ANL. <ul style="list-style-type: none"> – Under Controls, set input port to ANT. – Set Ref Level to –40 dBm. – Under Controls, select Main, select Auxiliary. – Under Controls, select AVG. Set Avg = 20. 	
4	<ul style="list-style-type: none"> – Record the reference level on the communications analyzer and <i>Note as P_S for reference</i>. – Replace the short with the antenna feedline. Record the reference level on the communications analyzer and <i>Note for as P_A reference</i>. – Record the difference of the two readings in dB. 	

... continued on next page

Transmit & Receive Antenna VSWR – continued

Table G-1: VSWR Measurement Procedure – HP Test Set

Step	Action	HP TEST SET
5	<p>Calculate the VSWR per the equation shown to the right.</p> <p>Where:</p> $R_L(\text{dB}) = P_A(\text{dBm}) - P_S(\text{dBm})$ <p>P_A = Power reflected from antenna P_S = Power reflected from short</p> <p>A calculated value of -13.98 dB equates to VSWR of better than 1.5:1.</p>	$VSWR = \frac{1 + 10^{\frac{R_L}{20}}}{1 - 10^{\frac{R_L}{20}}}$
6	If the readings indicate a potential problem, verify the physical integrity of all cables (including any in-line components, pads, etc.) and associated connections up to the antenna. If problem still persists, consult antenna OEM documentation for additional performance verification tests or replacement information.	
7	Repeat steps 2 through 6 for all remaining TX sectors/antennas.	
8	Repeat steps 2 through 6 for all remaining RX sectors/antennas.	

Figure G-1: Manual VSWR Test Setup Using HP8921 Test Set (1700/1900 MHz)

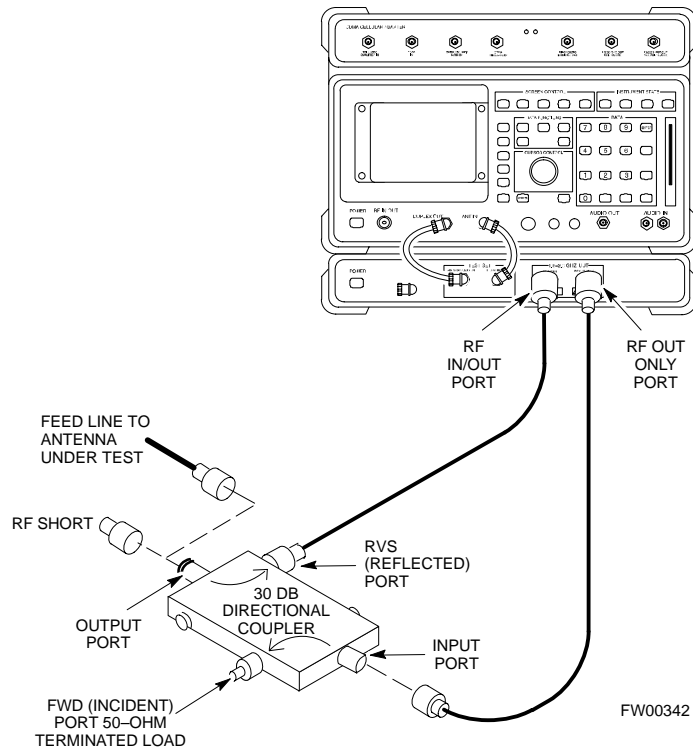

G

Figure G-2: Manual VSWR Test Setup Using HP8921 Test Set (800 MHz)

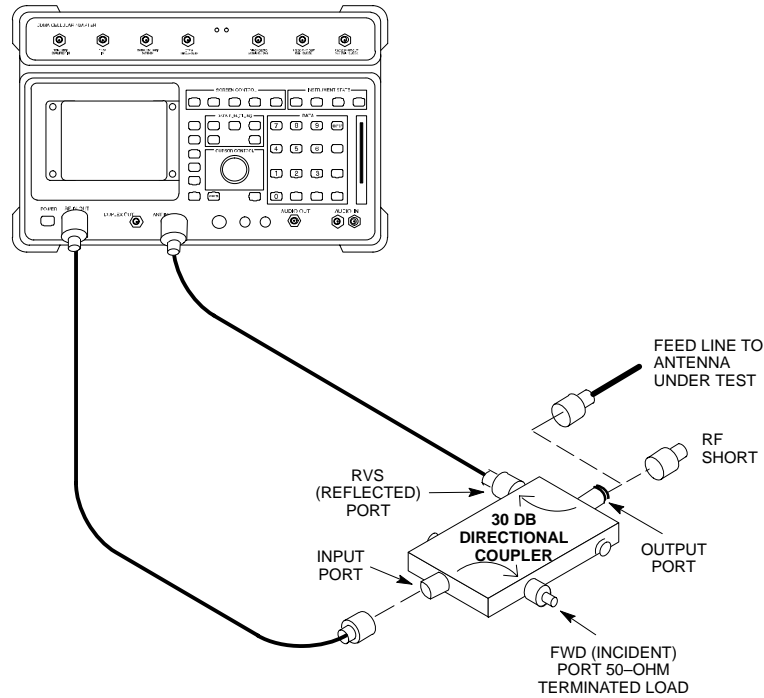

FW00343

Equipment Setup – Advantest Test Set

Follow the steps in Table G-2 to set up test equipment required to measure and calculate the VSWR for each antenna.

Table G-2: VSWR Measurement Procedure – Advantest Test Set

Step	Action	ADVANTEST
1	<i>If you have not already done so</i> , refer to the procedure in Table 3-2 on page 3-5 to set up test equipment and interface the LMF computer to the BTS.	
2	<p>For manual VSWR testing using external directional coupler, refer to Figure G-3.</p> <ul style="list-style-type: none"> – Connect the communications test set RF OUT port to the input port of the directional coupler. – Connect the INPUT port of the communication test set to the forward port on the directional coupler. Terminate the forward port with a 50 Ohm load. – Connect the RF short to the directional coupler output port. 	

... continued on next page



Transmit & Receive Antenna VSWR – continued

Table G-2: VSWR Measurement Procedure – Advantest Test Set

Step	Action	ADVANTEST
3	<p>Preform the following to instruct the calibrated test set to generate a CDMA RF carrier (RVL call) with all zero longcode at the assigned RX frequency at –10 dBm:</p> <ul style="list-style-type: none"> • Push the ADVANCE Measurement key. • Push the CDMA Sig CRT menu key. • Push the FREQ Entry key: <ul style="list-style-type: none"> – For 1900 MHz systems, set RF Gen Freq to center frequency of actual CDMA carrier between 1930–1990 MHz for TX and 1850–1910 MHz for RX. – For 800 MHz systems, set RF Gen Freq to center frequency of actual CDMA carrier between 869–894 MHz for TX and 824–849 MHz for RX. – For 1700 MHz systems, set RF Gen Freq to center frequency of actual CDMA carrier between 1840–1870 MHz for TX and 1750–1780 MHz for RX. • Push the LEVEL Entry key; set to 0 dBm (by entering 0 and pushing the –dBm key). • Verify that ON is active in the Output CRT menu key. • Verify that OFF is active in the Mod CRT menu key. • Push the CW Measurement key. • Push the FREQ Entry key. <ul style="list-style-type: none"> – Push the more 1/2 CRT menu key. – Set Preselect CRT menu key to 3.0G. • Push the Transient Measurement key. <ul style="list-style-type: none"> – Push the Tx Power CRT menu key. – Push the LEVEL entry key (set to 7 dBm by entering 7 and pushing the the dBm key). – Set Avg Times CRT menu key to ON. Set to 20 (by entering 20 and pushing the Hz ENTER key). • Push the REPEAT Start key to take the measurement. 	
4	Record the Burst Power display on the communications analyzer and <i>Note as P_S for reference.</i>	
5	Install the antenna feedline to the output port of the directional coupler.	
6	<ul style="list-style-type: none"> • Push the Auto Level Set CRT menu key. • Push the REPEAT Start key to take the measurement. 	
7	Record the Burst Power on the communications analyzer and <i>Note as P_A level for reference.</i> Record the difference of the two readings in dBm.	
8	<p>Calculate the VSWR per the equation shown to the right.</p> <p>Where:</p> $R_L(\text{dB}) = P_A(\text{dBm}) - P_S(\text{dBm})$ <p>P_A = Power reflected from antenna P_S = Power reflected from short</p> <p>A calculated value of –13.98 dB equates to VSWR of better than 1.5:1.</p>	$VSWR = \left[\frac{1 + 10^{\frac{R_L}{20}}}{1 - 10^{\frac{R_L}{20}}} \right]$

... continued on next page



Table G-2: VSWR Measurement Procedure – Advantest Test Set		
Step	Action	ADVANTEST
9	If the readings indicate a potential problem, verify the physical integrity of all cables (including any in-line components, pads, etc.) and associated connections up to the antenna. If problem still persists, consult antenna OEM documentation for additional performance verification tests or replacement information.	
10	Repeat steps 2 through 9 for all remaining TX sectors/antennas.	
11	Repeat steps 2 through 9 for all remaining RX sectors/antennas.	

Figure G-3: Manual VSWR Test Setup Using Advantest R3465

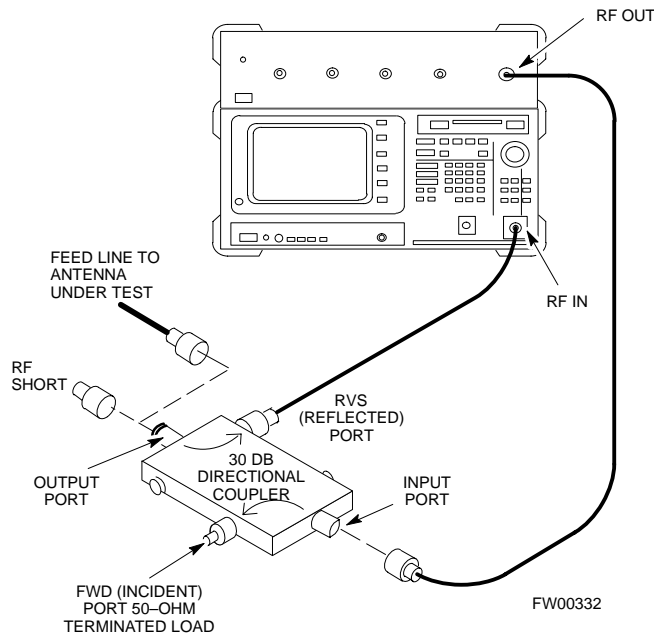

G

Appendix H: Download ROM Code

Appendix Content

Download ROM Code	H-1
Download ROM Code	H-1



Download ROM Code

Download ROM Code

ROM code can be downloaded to a device that is in any state. After the download is started, the device being downloaded changes to OOS_ROM (blue) and remains OOS_ROM (blue). The same R-level RAM code must then be downloaded to the device. This procedure includes steps for both the ROM code download and the RAM code download.

ROM code files cannot be selected automatically. The ROM code file must be selected manually. Follow the procedure in Table H-1 to download ROM code.

Prerequisite

- ROM and RAM code files exist for the device to be downloaded.



CAUTION

The R-level of the ROM code to be downloaded must be the same as the R-level of the ROM code for other devices in the BTS. Code must not be mixed in a BTS. This procedure should only be used to upgrade replacement devices for a BTS and it should not be used to upgrade all devices in a BTS. If a BTS is to be upgraded from one R-level to another, the optimization and ATP procedures must first be performed with the BTS in the original configuration. The upgrade should then be done by the CBSC.

Table H-1: Download ROM Code

Step	Action
	NOTE ROM code files cannot be selected automatically. The ROM code file must be selected manually.
1	Click on the device to be downloaded.
2	Click on the Device menu.
3	Click on the Status menu item. A status report window appears.
4	Make a note of the number in the HW Bin Type column.
5	Click on the OK button to dismiss the status report window.
6	Click on the Download Code Manual menu item. A file selection window appears.
7	Double-click on the version folder that contains the desired ROM code file.
8	Double-click on the Code folder. A list of ROM and RAM code files is displayed.

. . . continued on next page

Table H-1: Download ROM Code

Step	Action
	<p>! CAUTION</p> <p>A ROM code file having the correct hardware binary type (HW Bin Type) needs to be chosen. The hardware binary type (last four digits in the file name) was determined in step 4. Unpredictable results can happen and the device may be damaged (may have to be replaced) if a ROM code file with wrong binary type is downloaded.</p>
9	<p>Choose a ROM code file having the correct hardware binary type (HW Bin Type). The hardware binary type (last four digits in the file name) was determined in step 4.</p>
10	<p>Click on the ROM code file that matches the device type and HW Bin Type (e.g., bbx_rom.bin.0604 for a BBX having a HW Bin Type of 0604). The file should be highlighted.</p>
11	<p>Click on the Load button. A status report window displays the result of the download.</p>
12	<p>Click on the Ok button to close the status report window.</p>
13	<p>Click on the Util menu.</p>
14	<p>Select the Tools menu item.</p>
15	<p>Click on the Update NextLoad menu item.</p>
16	<p>Select the version number of the folder that was used for the ROM code download.</p>
17	<p>Click on the Save button. A pop-up message indicates that the CDF file has been updated.</p>
18	<p>Click on the OK button to dismiss the pop-up message.</p>
19	<p>Click on the device that was downloaded with ROM code.</p>
20	<p>Click on the Device menu.</p>
21	<p>Click on the Download Code menu item to download RAM code. A status report window displays the result of the download.</p> <p>NOTE</p> <p>Data is automatically downloaded to GLI devices when the RAM code is downloaded. Use the Download Data procedure to download data to other device types after they have been upgraded.</p>
22	<p>Click on the Ok button to close the status report window. The downloaded device should be OOS_RAM (yellow) unless it is a GLI in which case it should be INS (green).</p>
23	<p>Click on the device that was downloaded.</p>
24	<p>Click on the Device menu.</p>
25	<p>Click on the Status menu item. Verify that the status report window displays the correct ROM and RAM version numbers.</p>
26	<p>Click on the Ok button to close the status report window.</p>



Appendix I: In-Service Calibration

Appendix Content

Introduction	I-1
Purpose	I-1
Equipment Warm up	I-1
Power Delta Calibration	I-2
Power Delta Calibration Introduction	I-2
HP8921A Power Delta Calibration	I-2
Advantest R3465 Power Delta Calibration	I-4
HP8935 Power Delta Calibration	I-7
In-Service Calibration	I-10
In-Service Calibration	I-10



Introduction

Purpose

This procedure is a guide to expanding your system with multiple carriers while the system remains in service. This procedure also allows you to perform on site maintenance (replace defective boards and recalibrate) while the remainder of the site stays in service.

Motorola recommends that you perform this procedure during a maintenance window.

This procedure cannot be performed on BTSs with 4-to-1 combiners. The procedure can only be performed on one side of the BTS at one time. That is, LPAs 1, 2, 3, 7, 8, 9 (feed antennas 1, 2, 3) can be calibrated while LPAs 6, 7, 8, 10, 11, 12 (feed antennas 4, 5, 6) remain in service and vice versa.

Equipment Warm up



IMPORTANT

Calibration of the communications test set (or equivalent test equipment) **must be** performed at the site before calibrating the overall test set. Calibrate the test equipment *after* it has been allowed to warm-up and stabilize for a *minimum of 60 minutes*.



CAUTION

If any piece of test equipment (i.e., test cable, RF adapter) has been replaced, re-calibration must be performed. Failure to do so could introduce measurement errors, causing incorrect measurements and degradation to system performance.



Power Delta Calibration

Power Delta Calibration Introduction

The In-service calibration procedure has several differences from a normal calibration procedure. One of these is the use of a spectrum analyzer instead of a power meter to measure power. Power meters are broadband measurement devices and cannot be used to measure power during In-service Calibration since other carriers are operating. A spectrum analyzer can be used because it measures power at a given frequency. However, measuring power using a spectrum analyzer is less accurate than using a power meter. Therefore, you must compensate for the difference (delta) between the power meter and the spectrum analyzer.

HP8921A Power Delta Calibration

Use the HP8921A Spectrum Analyzer to measure power during In-Service Calibration for 800 MHz systems. After the offset value has been calculated, add it to the TX cable loss value.

Follow the procedure in Table I-1 to perform the HP8921A Power Delta Calibration procedure.

NOTE

This procedure requires two HP8921As.

Table I-1: HP8921A Power Delta Calibration Procedure

Step	Action
	* IMPORTANT Perform this procedure <i>after</i> test equipment has been allowed to warm-up and stabilize for a <i>minimum of 60 minutes</i> .
1	Connect a short RF cable between the HP8921A Duplex Out port and the HP437B power sensor (see Figure I-1).
2	Set the HP8921A signal source as follows: <ul style="list-style-type: none">– Measure mode to CDMA Generator– Frequency to the CDMA Calibration target frequency– CW RF Path to IQ– Output Port to Dupl– Data Source to Random– Amplitude to 0 dBm
3	Measure and record the power value reading on the HP437B Power Meter.
4	Record the Power Meter reading as result A _____.

. . . continued on next page

Power Delta Calibration – continued

Table I-1: HP8921A Power Delta Calibration Procedure	
Step	Action
5	Turn off the source HP8921A signal output, and disconnect the HP437B. NOTE Leave the settings on the source HP8921A for convenience in the following steps.
6	Connect the short RF cable between the source HP8921A Duplex Out port and the measuring HP8921A RF-IN port (see Figure I-2).
7	Ensure that the source HP8921A settings are the same as in Step 2.
8	Set the measuring HP8921A as follows: <ul style="list-style-type: none"> – Measure mode to CDMA Anl – Frequency to the CDMA calibration target frequency – Input Attenuation to 0 dB – Input port to RF-IN – Gain to Auto – Analyzer Direction to Fwd
9	Turn on the source HP8921A signal output.
10	Measure and record the channel power reading on the measuring HP8921A as result B _____.
11	Turn off the source HP8921A signal output and disconnect the equipment.
12	Compute the delta between HP437B and HP8921A using the following formula: Delta = A – B Example: Delta = –0.70 dBm – (–1.25 dBm) = 0.55 dBm Example: Delta = 0.26 dBm – 0.55 dBm = –0.29 dBm These examples are included to show the mathematics and do not represent actual readings. NOTE Add this delta value to the TX Cable Loss value during In–Service Calibration (see Step 4 in Table I-4).



Power Delta Calibration – continued

Figure I-1: Delta Calibration Setup – HP8921A to HP437B

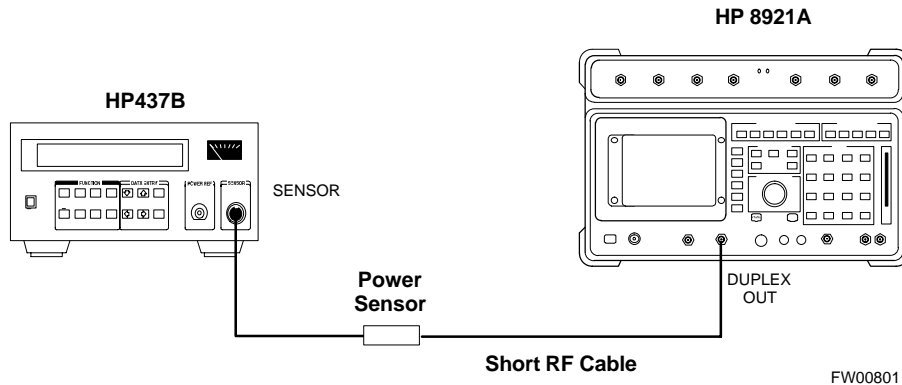
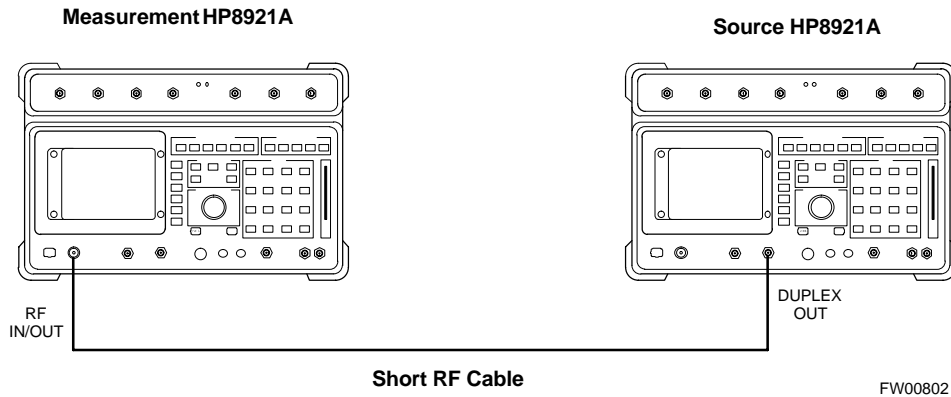

Figure I-2: Delta Calibration Setup – HP8921A to HP8921A



Advantest R3465 Power Delta Calibration

Follow the procedure in Table I-2 to perform the Advantest 3465 Power Delta Calibration procedure.

Table I-2: Advantest Power Delta Calibration Procedure

Step	Action
	* IMPORTANT Perform this procedure <i>after</i> test equipment has been allowed to warm-up and stabilize for a <i>minimum of 60 minutes</i> .
On the Advantest R3465:	
1	Press the SHIFT and the PRESET keys located below the CRT display.
2	Press the ADVANCE key in the Measurement area of the control panel.
3	Press the CDMA Sig CRT menu key.
4	Press the FREQ key in the Entry area of the control panel.

... continued on next page

Power Delta Calibration – continued

Table I-2: Advantest Power Delta Calibration Procedure

Step	Action
5	Set the frequency to the desired value using the keypad entry keys.
6	Press the LEVEL key in the Entry area of the control panel.
7	Set the LEVEL to 0 dBm using the keypad entry keys.
8	Verify the Mod CRT menu key is highlighting OFF , if not press the Mod key to toggle it OFF .
9	Verify the Output CRT menu key is highlighting OFF , if not press the Output key to toggle it OFF .
On the HP 437 Power Meter:	
10	Zero the Power Meter prior to connecting the power sensor to the RF cable from the signal generator. * IMPORTANT For best accuracy, always re-zero the power meter before connecting the power sensor to the component being calibrated.
11	Connect the RF cable from the R3561L CDMA Test Source Unit RF OUT port to the power sensor, refer to Figure I-3.
12	Press the Output CRT menu key to toggle the Output to ON .
13	Record the Power Meter reading as result A _____.
14	Press the Output CRT menu key to toggle the Output to OFF .
15	Connect the RF cable from the R3561L CDMA Test Source Unit RF OUT port to the Spectrum Analyzer INPUT Port, refer to Figure I-4.
16	Press the Output CRT menu key to change the Output to ON .
17	Press the CW key in the Measurement area of the control panel.
18	Press the LEVEL key in the Entry area of the control panel.
19	Set the REF LEVEL to 10 dBm using the keypad entry keys.
20	Press the dB/div CRT menu key.
21	Press the 10 dB/div CRT menu key.
22	Press the FREQ key in Entry area of the control panel.
23	Set the frequency to the desired value using the keypad entry keys.
24	Press the more 1/2 CRT menu key.
25	Press the Preselector CRT menu key to highlight 3.0G .
26	Press the FORMAT key in the Display Control area of the control panel.
27	Press the TRACE CRT menu key.
28	Press the AVG A CRT menu key.
29	Set AVG to 20 using keypad entry keys.

... continued on next page

Power Delta Calibration – continued

Table I-2: Advantest Power Delta Calibration Procedure	
Step	Action
30	Press the return CRT menu key.
31	Press the SPAN key in the Entry area of the control panel.
32	Press the Zero Span CRT menu key.
33	Press the BW key in the Entry area of the control panel.
34	Press the RBW CRT menu key to highlight MNL . using keypad entry keys enter 30 kHz .
35	Set RBW to 30 kHz using keypad entry keys.
36	Press the VBW CRT menu key to highlight MNL .
37	Set VBW to 1 MHz using keypad entry keys.
38	Press the Marker ON key in the Display Control area of the control panel.
39	Record the Marker Level reading as result B _____.
40	<p>Calculate the Power Calibration Delta value. The delta value is the power meter measurement minus the Advantest measurement.</p> <p style="padding-left: 40px;">Delta = A – B</p> <p style="padding-left: 40px;">Example: Delta = –0.70 dBm – (–1.25 dBm) = 0.55 dBm</p> <p style="padding-left: 40px;">Example: Delta = 0.26 dBm – 0.55 dBm = –0.29 dBm</p> <p>These examples are included to show the mathematics and do not represent actual readings.</p> <p>NOTE</p> <p>Add this delta value to the TX Cable Loss value during In–Service Calibration (see Step 4 in Table I-4).</p>

Figure I-3: Delta Calibration Setup – R3561L to HP437B

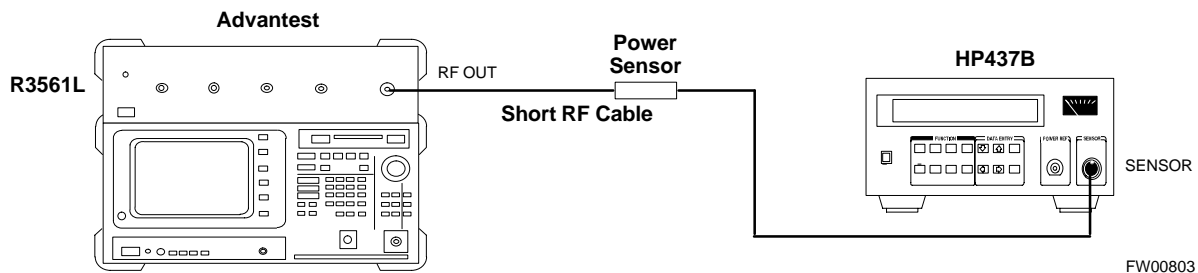

Power Delta Calibration – continued

Figure I-4: Delta Calibration Setup – R3561L to R3465

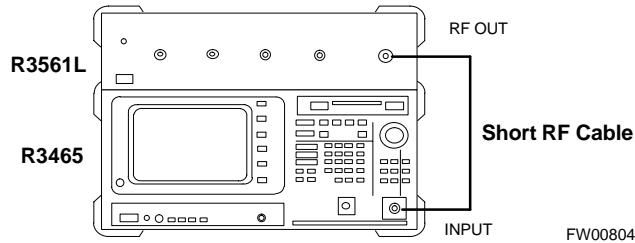

HP8935 Power Delta Calibration

Follow the procedure in Table I-3 to perform the HP8935 Power Delta Calibration procedure.

Table I-3: HP8935 Power Delta Calibration Procedure

Step	Action
	<p>* IMPORTANT Perform this procedure <i>after</i> test equipment has been allowed to warm-up and stabilize for a <i>minimum of 60 minutes</i>.</p>
1	Connect a short RF cable between the HP8935 Duplex Out port and the HP437B power sensor (see Figure I-5).
2	Set the HP8935 signal source as follows: <ul style="list-style-type: none"> – Measure mode to CDMA Gen – Frequency to the CDMA Calibration target frequency – CW RF Path to IQ – Output Port to Dupl – Data Source to Random – Amplitude to 0 dBm
3	Measure and record the power value reading on the HP437B Power Meter.
4	Record the Power Meter reading as result A _____.
5	Turn off the source HP8935 signal output, and disconnect the HP437B. NOTE Leave the settings on the source HP8935 for convenience in the following steps.
6	Connect the short RF cable between the source HP8935 Duplex Out port and the RF-IN/OUT port (see Figure I-6).
7	Ensure that the source HP8935 settings are the same as in Step 2.

... continued on next page

Power Delta Calibration – continued

Table I-3: HP8935 Power Delta Calibration Procedure	
Step	Action
8	Set the measuring HP8935 as follows: <ul style="list-style-type: none"> – Measure mode to CDMA AnI – Frequency to the CDMA calibration target frequency – Input Attenuation to 0 dB – Input port to RF-IN – Gain to Auto – AnI Dir to Fwd
9	Turn on the source HP8935 signal output.
10	Set the Chn Pwr Cal to Calibrate and select to calibrate.
11	Measure and record the channel power reading on the measuring HP8935 as result B _____.
12	Turn off the source HP8935 signal output and disconnect the equipment.
13	<p>Calculate the Power Calibration Delta value. The delta value is the power meter measurement minus the Advantest measurement.</p> <p style="padding-left: 40px;">Delta = A – B</p> <p style="padding-left: 40px;">Example: Delta = –0.70 dBm – (–1.25 dBm) = 0.55 dBm</p> <p style="padding-left: 40px;">Example: Delta = 0.26 dBm – 0.55 dBm = –0.29 dBm</p> <p>These examples are included to show the mathematics and do not represent actual readings.</p> <p>NOTE</p> <p>Add this delta value to the TX Cable Loss value during In–Service Calibration (see Step 4 in Table I-4).</p>

Figure I-5: Delta Calibration Setup – HP8935 to HP437B

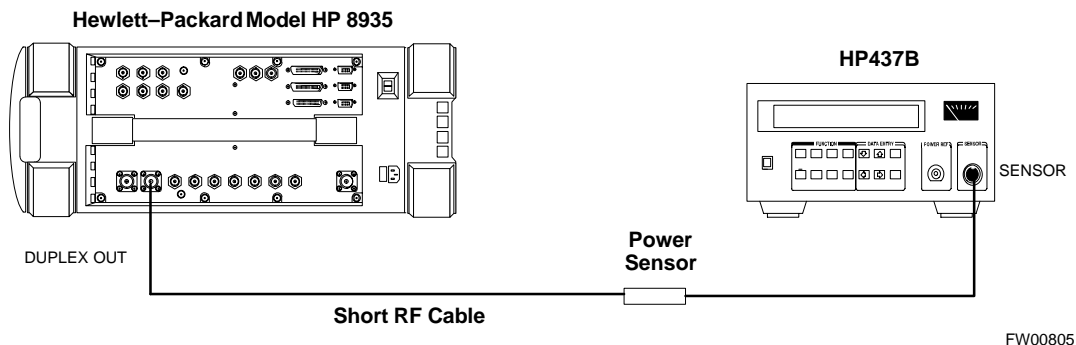
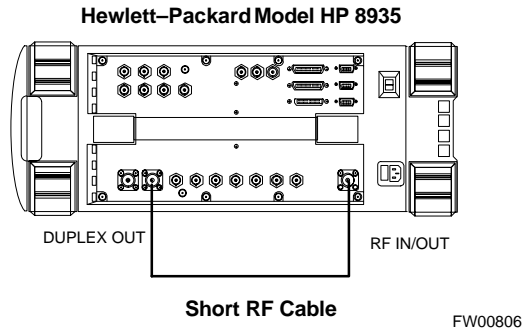

Figure I-6: Delta Calibration Setup – HP8935 to HP8935



In-Service Calibration



IMPORTANT

This feature does NOT have fault tolerance at this time. The system has no safe-guards to stop you from doing something that will take the BTS out of service. If possible, perform this procedure during a maintenance window.

Follow the procedures in this section precisely, otherwise the entire BTS will most likely go OUT OF SERVICE.

At the CBSC, only perform operations on expansion hardware when it is in the OOS_MANUAL state.

The operator must be trained in the LMF operation prior to performing this procedure.

Prerequisites

- Expansion hardware has been added in the CBSC database, and the CDF file has been generated.
- The expansion devices have been inserted into the C-CCP cage and are in the OOS_MANUAL state at the CBSC.
- The site specific cdf (with the expansion hardware) and cal files have been loaded onto the LMF.
- The LMF has the same code and dds files as the CBSC to download.



IMPORTANT

Do not download code or data to any cards other than those you are working on. Downloading code or data to other cards will take the site OUT OF SERVICE.

The code file version numbers must match the version numbers on the other cards in the frame. If the numbers do not match, the site may go OUT OF SERVICE.

The BTS-#.cdf, CBSC-#.cdf, and CAL files for this BTS must have come from the CBSC.

- Test equipment has been configured per Figure I-7 or Figure I-8.
- An RFDS (or at a minimum a directional coupler), whose loss is already known, must be in line to perform the in-service calibration.
- Test equipment has been calibrated after 1 hour warm up.
- A short RF cable and two BNC-N adapters are available to perform Cable Calibration.

. . . continued on next page

- The Power Delta Calibration has been performed (see Table I-1, Table I-2, or Table I-3).

Figure I-7: Optimization/ATP Test Setup Using Directional Coupler

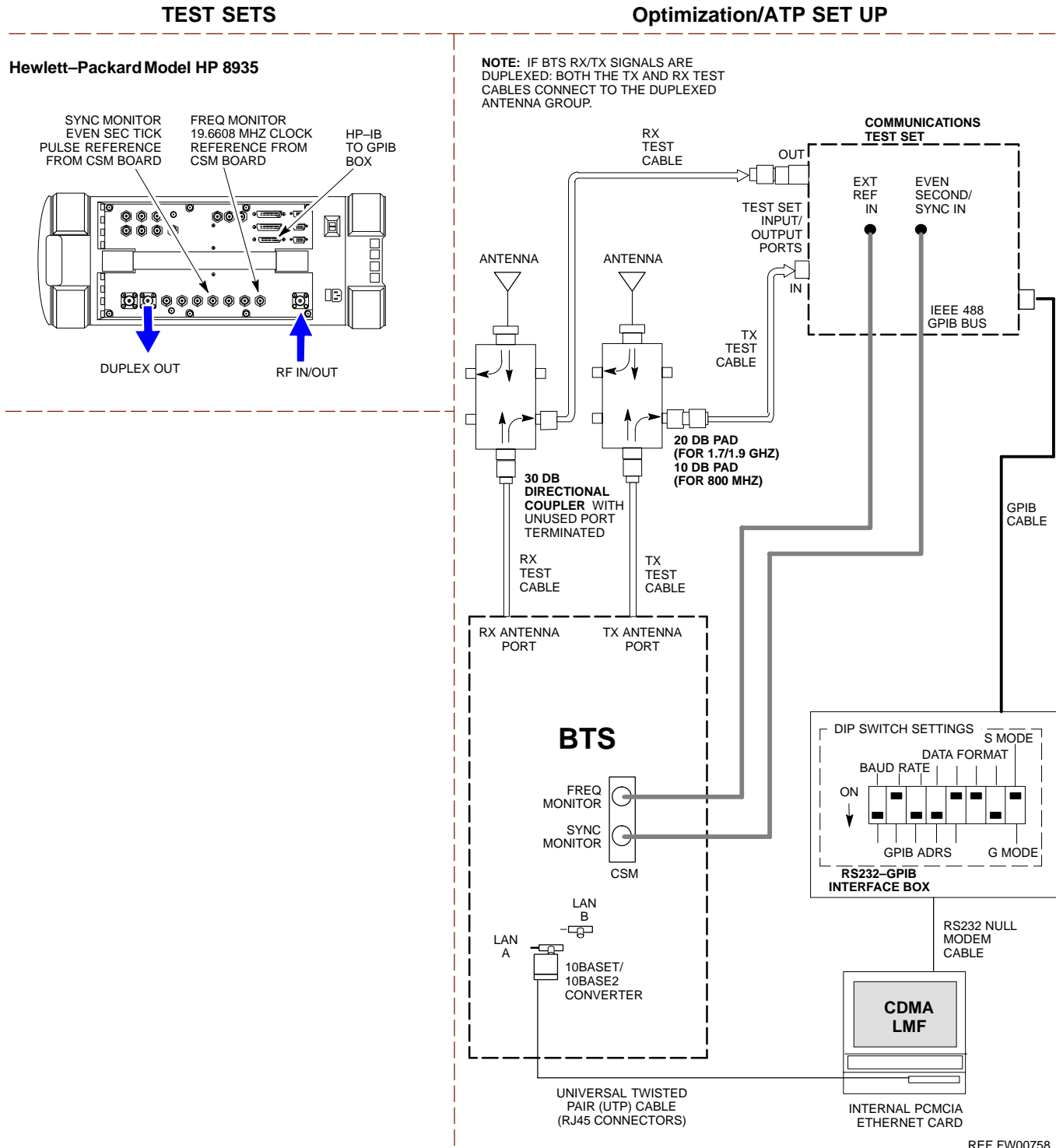
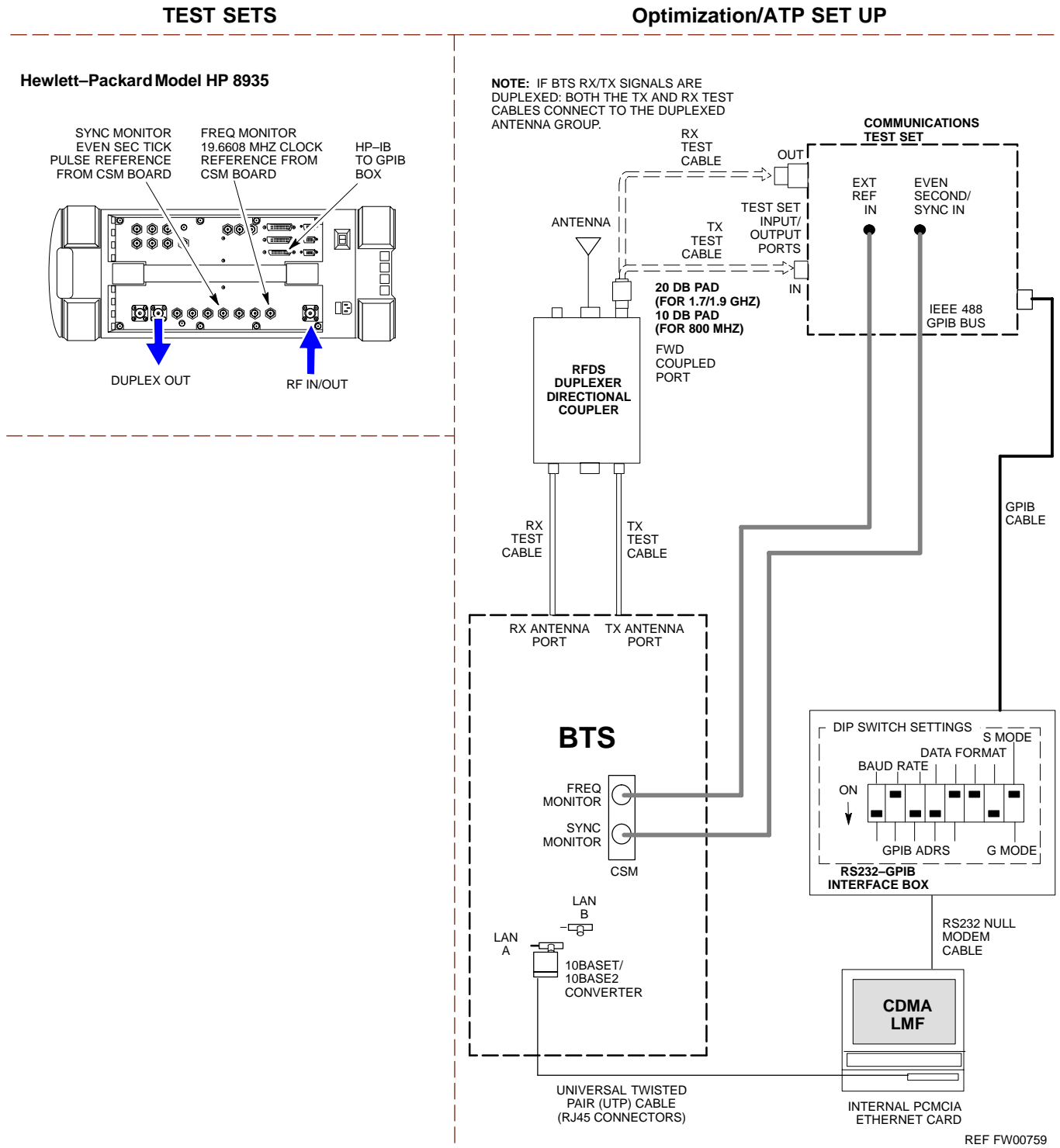

Figure I-8: Optimization/ATP Test Setup Using RFDS



Follow the procedure in Table I-4 to perform the In-Service Calibration.

Table I-4: In-Service Calibration	
Step	Action
	<p>* IMPORTANT</p> <p>Perform this procedure <i>after</i> test equipment has been allowed to warm-up and stabilize for a <i>minimum of 60 minutes</i>.</p>
1	<p>Set up the LMF for In-Service Calibration:</p> <ul style="list-style-type: none"> – Start the LMF by double-clicking the LMF icon on the Windows desktop. – Click Options>LMF Options from the menu bar at the login screen. – Check only the applicable spectrum analyzer check box on the Test Equipment tab. Ensure that the GPIB address is 18. – Uncheck any other other equipment that is selected. – Click the Apply button. – Select the BTS Options tab in the LMF Option window. – Check the In-Service Calibration check box. – Click the Apply button. – Click the Dismiss button to close the LMF Option window.
2	<p>Login to the target BTS:</p> <ul style="list-style-type: none"> – Select the target BTS icon. – Click the Login button at the login screen.
3	<p>Measure the Cable Loss using the Cable Calibration function:</p> <ul style="list-style-type: none"> – Click Util>Cable Calibration from the menu bar at the main window. – Set the desired channel(s) and select TX and RX CABLE CAL at the cable calibration pop up window. – Click the OK button to perform cable calibration. – Follow the on-screen instructions to complete the cable loss measurement. <p>NOTE</p> <ul style="list-style-type: none"> – The measured value is input automatically to the cable loss file. – To view the cable loss file, click Util>Examine>Cable Loss.

. . . continued on next page



Table I-4: In-Service Calibration

Step	Action
4	<p>Add the spectrum analyzer power delta to the Cable Loss.</p> <ul style="list-style-type: none"> – To view the cable loss file, click Util>Examine>Cable Loss. – Add the value computed in Table I-1, Table I-2, or Table I-3 to the TX Cable Loss. <p>NOTE</p> <p>Be sure to include the sign of the value. The following examples are included to show the mathematics and do not represent actual readings:</p> <ul style="list-style-type: none"> – Example: 5.65 dBm + 0.55 dBm = 6.20 dBm – Example: 5.65 dBm + (–0.29 dBm) = 5.36 dBm – Example: –5.65 dBm + 0.55 dBm = –5.10 dBm – Example: –5.65 dBm + (–0.29 dBm) = –5.94 dBm
5	<p>Input the Coupler Loss for the TX tests:</p> <ul style="list-style-type: none"> – Click Util>Edit>TX Coupler Loss from the menu bar at the main window. – Input the appropriate coupler loss for the target carrier(s) by referring to the information taken at the time of BTS installation. – Click the Save button. – Click the Dismiss button to close the window. – To view the coupler loss file, click Util>Examine>TX Coupler Loss.
6	<p>Input the Coupler Loss for the RX tests:</p> <ul style="list-style-type: none"> – Click Util>Edit>Cable Loss from the menu bar at the main window. – Add the appropriate coupler loss to the cable loss for the target carrier(s) by referring to the information taken at the time of BTS installation and input this value in the Cable Loss field. – Click the Save button. – Click the Dismiss button to close the window. – To view the cable loss file, click Util>Examine>Cable Loss.
7	<p>Have the CBSC operator put the redundant BBX OOS_MANUAL.</p>
	<p>! CAUTION</p> <p>Be sure to download OOS devices only. Loading in-service devices takes them OUT OF SERVICE and can result in dropped calls.</p> <p>The code file version numbers must match the version numbers on the other cards in the frame. If the numbers do not match, the site may go OUT OF SERVICE.</p> <p>NOTE</p> <p>Be sure to include the redundant BBX in steps 8, 9, and 10.</p>

... continued on next page

Table I-4: In-Service Calibration

Step	Action
8	Download code and data to the target devices: <ul style="list-style-type: none"> – Click Util>Tools>Update NextLoad to set the code version that will be downloaded. – Check the appropriate code version in the pop up window and click the Save button to close. – Select the target BBX(s) on the C-CCP cage picture. – Click Device>Download Code to start downloading code. – Select the target BBX(s) on the C-CCP cage picture. – Click Device>Download Data to start downloading data.
9	<p>! CAUTION Perform the All Cal/Audit procedure on OOS devices only.</p> Run the All Cal/Audit procedure: <ul style="list-style-type: none"> – Select the target BBX(s) on the C-CCP cage picture. – Click Tests>All Cal/Audit from the menu bar at the main window. – Select the target carrier and confirm the channel number in the pop up window. – Leave the Verify BLO check box checked and click the OK button to start calibration. – Follow the on-screen instructions, except, do not connect to the BTS antenna port, connect to the directional coupler (fwd) port associated with the on screen prompt antenna port.
10	Save the result and download the BLO data to the target BBX(s): <ul style="list-style-type: none"> – Click the Save Result button on the result screen. The window closes automatically.
11	Logout from the BTS and close the LMF session: <ul style="list-style-type: none"> – Click Select>Logout to close the BTS connection. – Close the LMF window.
12	Restore the new “bts-*.cal” file to the CBSC.
13	Enable the target device(s) from the CBSC.



Numbers

- 10BaseT/10Base2 Converter, 1-8
 - LMF to BTS connection, 3-5
- 1700 MHz Center Frequencies, Calculating, E-7
- 1700 MHz PCS Channels, E-6
- 1900 MHz Center Frequencies, Calculating, E-2
- 1900 MHz PCS Channels, E-1
- 2-way Splitter, 1-11
- 3C-PC-COMBO CBL, 1-8
- 800 MHz CDMA Channels, E-4
- 800 MHz Center Frequencies, Calculating, E-4

A

- ACTIVE LED
 - GLI2, 6-23
 - MCC, 6-25
- Advantest R3465, 3-43
 - Calibrating Test Cable, F-8
- Alarm Connector Location/Pin Numbering SC 4850/4850E, 3-85
- ALARM LED, GLI2, 6-23
- Alarm Monitor window, 3-84
- Alarm Reporting Display, 3-84
- All Cal/Audit Test, 3-72, 3-73
- All RX, 4-1
- All TX, 4-1
- All TX/RX, 4-2
- AMR, No control, 6-16
- AMR CDI Alarm Input Verification, test data sheets, A-17

- Ancillary Equipment Frame identification, 1-13
- Ancillary frame, when to optimize, C-1
- Antenna Map, 3-80
- ATP, 4-1
 - Code Domain Power, 4-10
 - Frame Error Rate (FER), 4-12
 - generate report, 4-13
 - Pilot Time Offset, 4-9
 - Report, 4-13
 - Spectral Purity Transmit Mask, 4-6
 - test matrix/detailed optimization, C-2
 - Test Prerequisites, 4-2
 - Test Procedure, 4-3
 - testing options, 4-3
 - Waveform Quality (rho), 4-8
- Automated Acceptance Test Procedure, 4-1

B

- Backplane DIP switch settings, 2-3
- Bay Level Offset calibration failure, 6-6
- BBX
 - Connector, 6-14
 - gain set point vs BTS output considerations, D-1
 - No control in the shelf, 6-16
- BLO
 - Calibration, 3-63
 - Calibration Audit, 3-70
 - calibration data file, 3-65
 - Calibration Failure, 6-6
 - Download, 3-70
- BTS
 - Ethernet LAN interconnect diagram, 3-14
 - LMF connection, 3-5
 - system software download, 3-3
 - test data sheets, redundancy/alarm tests, A-16
 - when to optimize, C-1

- BTS frame
 - DC Distribution Pre-test, 2-9
 - DC Power Pre-test, 2-7
 - initial power-up, 2-14
- Create CAL File, 3-74
- C**
- C-CCP Backplane, Troubleshooting, 6-13, 6-14
- C-CCP Shelf, 1-19
 - Site Serial Number Check List, A-18
- Cable
 - GPIB, 1-9
 - LAN Cable, 1-10
 - Calibrating, 3-45, 3-56, 3-57
 - Null Modem, 3-34
 - Setting Loss Values, 3-61
 - Timing Reference, 1-9
- Cable Calibration
 - HP8921 with HP PCS  Manual, F-3
- CAL File, 3-74
- Calculating Center Frequencies
 - 1700 MHz, E-7
 - 1900 MHz, E-2
 - 800 MHz, E-4
- Calibrating
 - Cables, 3-56
 - RX, 3-59
 - TX, 3-58
 - Test Equipment, 3-56
- Calibrating Test Cable, Advantest R3465, F-8
- Calibration
 - BLO, 3-63
 - Cable, 1-6
 - data file, BLO, 3-65
 - In-Service, I-13
 - RF Path, Test Equipment Setup, 3-67
 - RFDS, 3-82
 - Test Equipment, 1-6
 - TX Path, 3-64, 3-68
- Test Cable Calibration, 1-6
- Test Equipment Calibration, 1-6
- Calibration Audit Failure, Troubleshooting, 6-7
- Cannot communicate to Communications Analyzer, 6-3
- Cannot communicate to Power Meter, 6-2
- Cannot download CODE to any device card, 6-4
- Cannot Download DATA to any device card, 6-4
- Cannot ENABLE device, 6-5
- Cannot load BLO, 6-7
- Cannot Log into cell-site, 6-2
- Cannot perform carrier measurement, 6-9
- Cannot perform Code Domain Noise Power measurement, 6-9
- Cannot perform Rho or pilot time offset measurement, 6-8
- Cannot perform Txmask measurement, 6-8
- Carrier Measurement Failure, Troubleshooting, 6-9
- CDF
 - site configuration, 3-2
 - site equipage verification, 3-3
 - site type and equipage data information, 2-1
- CDF Files, Copy from CBSC, 3-8
- CDI Alarm
 - with Alarms Test Box, 3-86
 - without Alarms Test Box, 3-89
- CDMA LMF, Product Description, 1-2
- Cell Site
 - equipage verification, 2-1
 - preliminary operations, 2-1
 - types, 3-2
- Cell Site Data File. *See* CDF
- Channel elements, No or missing, 6-17
- Channels
 - 1700 MHz, E-6
 - 1900 MHz, E-1
 - 800 MHz, E-4
- Checksum Failure, 6-11
- CIO, Connectors, 6-14
- CLI, 1-3, 3-19
 - Command Line Interface, 3-18
 - Format Conventions, 3-19
 - Logging Out, 3-23
- Cobra RFDS
 - external housing, 1-33

- RF connector panel detail, 1-33
- Code Domain Power, 4-5
 - ATP, 4-10
- Code Domain Power and Noise Floor Measurement Failure, Troubleshooting, 6-9
- Code Domain Power Test, 4-10
- Code Download Failure, Troubleshooting, 6-4
- Command Line Interface, 1-3, 3-19
- Common power supply verification, 2-13
- Communications Analyzer Communication Failure, Troubleshooting, 6-3
- Communications System Analyzer, 1-9
 - Advantest, 1-9
 - HP8921A/600, 1-9
 - CyberTest, 1-9
 - HP8935 Analyzer, 1-9
- Connector Functionality, Backplane, Troubleshooting, 6-13
- Copy CAL files from CDMA LMF to the CBSC, 5-6
- Copy CAL Files From Diskette to the CBSC, 5-7
- Copy CDF Files from CBSC, 3-8
- Copy Files to a Diskette, 5-6
- Copy CAL files to the CBSC, 5-7
- CSM
 - Clock Source, 3-28, 3-29
 - Enable, 3-29
 - frequency verification, 3-34
 - functions, 3-32
 - LEDs, 3-33
 - MMI terminal connection, illustration, 3-35
 - Reference Source Configuration Error, 6-11
 - Troubleshooting, 6-11, 6-12
- CyberTest, 3-43
- D**
- Data Download Failure, Troubleshooting, 6-4
- DC Power Pre-test
 - +27 V BTS frame detail, 2-7
 - 48 V BTS frame detail, 2-9
 - BTS Frame, 2-5
 - RFDS, 2-11
 - RFDS detail, 2-11
- DC Power Problems, 6-18
- DC/DC Converter, LED Status Combinations, 6-20
- Device Enable (INS) Failure, Troubleshooting, 6-5
- Digital Control Problems, C-CCP Backplane Troubleshooting, 6-15
- Digital Multimeter, 1-9
- Directional Coupler, 1-10
- Download
 - BLO, 3-70
 - BTS, 3-25
 - BTS system software, 3-3
 - MGLI, 3-26
 - Non-MGLI2 Devices, 3-28
 - ROM Code, H-1
- E**
- E1, isolate BTS from the E1 spans, 3-4
- Enable
 - CSMs, 3-29
 - MCCs, 3-31
 - Redundant GLIs, 3-31
- Enabling Devices, 5-2
- Equipment setup, VSWR, HP Test Set, G-2
- Ethernet LAN
 - interconnect diagram, 3-14
 - Transceiver, 1-7
- Ethernet maintenance connector interface, illustration, 3-6
- F**
- FER test, 4-12
- Folder Structure Overview, 3-13
- Frame Error Rate, 4-5
 - ATP, 4-12
- FREQ Monitor Connector, CSM, 6-22
- Frequency counter, optional test equipment, 1-10
- Frequency Spectrum
 - Korean PCS (1700 MHz), E-6
 - North American Cellular Telephone System (800 MHz), E-4
 - North American PCS (1900 MHz), E-1
- Full Optimization, 4-2
- G**
- Gain set point, BBX, D-1

Generating an ATP Report, 4-13

General optimization checklist, test data sheets, A-4

Gigatronics Power Meter, 3-43

GLI. *See* Master (MGLI2) and Slave (SGLI2) Group Line Interface

GLI2

- Connector, 6-14
- Ethernet Connections, 6-14
- LED Status, 6-23
- No Control through span line connection, 6-15
- No Control via LMF, 6-15

GPIB Cable, 1-9

GPS

- Initialization/Verification, 3-36
- receiver operation, test data sheets, A-5
- satellite system, 3-30
- Test Equipment Setup, 3-34

GPS Bad RX Message Type, 6-11

Graphical User Interface, 1-3, 3-18

GUI, 1-3, 3-18

- Graphical User Interface, 3-18
- Logging Out, 3-22

H

LMF Hardware Requirements, 1-7

High Stability 10 MHz Rubidium Standard, 1-11

High Stability Oscillator, 3-33

High-impedance Conductive Wrist Strap, 1-10

HP 437B, 3-43

HP 83236 A, F-3

HP 83236A, F-2

HP 8921, 3-43

HP 8921A, System Connectivity Test, F-2

HP 8935, 3-43

HP PCS Interface Test Equipment Setup for Manual Testing, F-7

HP Test Set, VSWR, G-2

HSO, Initialization/Verification, 3-42

HyperTerminal Connection, Creating, 3-10

I

I and Q values, B-1

In-Service Calibration, I-13

Initial Installation of Boards/Modules, preliminary operations, 2-1

Initial power tests, test data sheets, A-3

Initial power-up

- BTS frame, 2-14
- RFDS, 2-14

Initialization/Verification

- GPS, 3-36
- HSO, 3-42
- LFR, 3-39

Intended reader profile, 1-12

Inter-frame cabling, when to optimize, C-2

IS-97 specification, B-1

ISB connectors, 6-13

Isolation, T1/E1 Span, 3-4

Itasca Alarms Test Box, 1-11

L

LAN

- BTS frame interconnect, illustration, 3-14
- Tester, 1-11

LAN Connectors, GLI2, 6-24

LED, CSM, 3-33

LED Status, 6-20

- BBX, 6-25
- CSM, 6-21
- DC/DC Converter, 6-20
- GLI2, 6-23
- LPA, 6-26
- MCC, 6-25

LFR

- Initialization / Verification, 3-39
- receiver operation, test data sheets, A-6

LFR/HSO, Test Equipment Setup, 3-34

Line Build Out parameters

- configure, 5-4
- verify, 5-3

LMF, 1-6, 3-7

- Ethernet maintenance connector interface detail, illustration, 3-6

- Installation and Update Procedures, 3-7
 - Termination and Removal, 5-7
 - to BTS connection, 3-5
 - LMF Operation, 3-18
 - LMF Removal, 5-6
 - Loading Code, 3-25
 - Logging In to a BTS, 3-20
 - Logging Out, 3-22
 - CLI, 3-23
 - GUI, 3-22
 - Logical BTS, 1-13
 - Numbering, 1-14
 - Login
 - CLI, 3-22
 - GUI, 3-20
 - Login Failure, Troubleshooting, 6-2
 - Low Frequency Receiver, 3-33
 - LPA, test data sheets
 - convergence, A-8
 - IM Reduction, A-7
 - LPA Module LED, 6-26
 - LPAs, Site Serial Number Check List, A-19
- M**
- Manual
 - layout, 1-1
 - overview, 1-2
 - MASTER LED, GLI2, 6-23
 - MCC, Enable, 3-31
 - MGLI2
 - board detail, MMI port connections, 5-4
 - Download, 3-26
 - Miscellaneous errors, Troubleshooting, 6-5
 - MMI Connection, 3-24
 - MMI Connector
 - CSM, 6-22
 - GLI2, 6-24
 - MCC, 6-25
 - MMI equipment setup, 3-24
 - Model SLN2006A MMI Interface Kit, 1-9
 - Module status indicators, 6-20
 - Multi-FER test Failure, Troubleshooting, 6-10
- N**
- NAM, Valid Ranges, 3-79
 - No DC input voltage to Power Supply Module, 6-18
 - No DC voltage +5 +65 or +15 Volts to a specific GLI2 BBX or Switch board, 6-19
 - No GPS Reference Source, 6-11
 - Non-MGLI2, Download, 3-28
 - Null Modem Cable, 3-34
- O**
- Online Help, 1-3
 - Optimization
 - Process, 3-1
 - purpose, 1-4
 - When, 1-5
 - Optional Test Equipment, 1-10
 - frequency counter, 1-10
 - Oscilloscope, 1-11
- P**
- PA Shelves, 1-20
 - path
 - RX, 1-4
 - TX, 1-4
 - PCMCIA, Ethernet adapter, LMF to BTS connection, 3-5
 - Pilot Gain, 4-8, 4-9, 4-10, 4-12
 - Pilot Offset Acceptance test, 4-9
 - Pilot Time Offset, 4-5, 4-9
 - Pin/Signal Information for ARM A Cable, 3-90
 - Ping, 3-14
 - PN Offset
 - programming information, B-1
 - usage, B-1
 - PnMask, I and PnMask Q Values, B-2
 - Power Conversion Shelf (–48 V BTS Only), Site Serial Number Check List, A-19
 - Power Delta Calibration
 - Advantest, I-4
 - HP8921A, I-2

- HP8935, I-7
- Power Input, 6-13
- Power Meter, 1-9
- Power Meter Communication Failure, Troubleshooting, 6-2
- Power Supply Module Interface, 6-14
- Pre-power tests, test data sheets, A-3
- Preliminary operations
 - cell Site types, 2-1
 - test data sheets, A-2
- Prepare to Leave the Site
 - external test equipment removal, 5-1
 - LMF Removal, 5-6
 - re-connect BTS IFM connector, 5-8
 - re-connect BTS T1 spans, 5-8
 - Reestablish OMC-R control, 5-8
 - Verify T1/E1, 5-8
- Pushbuttons and Connectors, GLI2, 6-24
- PWR/ALM LED
 - BBX, 6-25
 - CSM, 6-21
 - DC/DC Converter, 6-20
 - generic, 6-20
 - MCC, 6-25
- R**
- RDM, 6-13
- Re-connect BTS IFM connector, 5-8
- Re-connect BTS T1 Spans, 5-8
- Redundant GLIs, Enable, 3-31
- Reestablish OMC-R control, 5-8
- Reference Distribution Module, 6-13
- Required documents, 1-12
- RESET Pushbutton, GLI2, 6-24
- Resetting BTS modules, 5-2
- RF
 - Adapters, 1-10
 - Attenuators, 1-10
 - Load, 1-10
- RF Path Calibration, 3-67
- RFDS
 - Calibration, 3-82
 - DC Power Pre-test, 2-11
 - Description, 3-75
 - initial power-up, 2-14
 - Layout, 1-33
 - Parameter Settings, 3-76
 - Set Configuration Data, 3-81
- rho, 4-5
- rho test, 4-8
- ROM Code, Download, H-1
- RS-232 to GPIB Interface, 1-8
- Rubidium Standard Timebase, 3-43
- RX, antenna VSWR, test data sheets, A-17
- RX Acceptance Tests, Frame Error Rate, 4-5, 4-12
- RX path, 1-4
- S**
- Sector Configuration, 1-28
- Set Antenna Map Data, 3-80
- Set Span Parameter Configuration, procedure, 5-4
- Setting Cable Loss Values, 3-61
- Setting TX Coupler Loss Value, 3-62
- SGLI2, board detail, MMI port connections, 5-4
- Shelf Configuration Switch, 2-3
- Signal Generator, 3-58, 3-59
- Site, equipage verification, 3-3
- Site checklist, data sheets, A-2
- Site equipage, CDF file, 3-2
- Site I/O board, T1 span cable connection, 5-8
- Site Serial Number Check List, A-18
- Span Framing Format
 - configure, 5-4
 - verify, 5-3
- Span I/O board
 - E1 span isolation, illustration, 3-5
 - T1 span isolation, illustration, 3-5
- Span Line
 - connector, 6-13
 - T1/E1 Verification Equipment, 1-11
- Span line traffic, No or missing, 6-16

Span Parameter Configuration
 set, procedure, 5-4
 verification, procedure, 5-3

Span Problems, no control link, 6-27

SPANS LED, GLI2, 6-23

Spectral Purity Transmit Mask ATP, 4-6

Spectral Purity TX Mask, 4-5

Spectrum Analyzer, 1-11, 3-58, 3-59

Spectrum Analyzer , HP8594E, 3-43

STATUS LED, GLI2, 6-23

SYNC Monitor Connector, CSM, 6-22

System Connectivity Test, HP8921A, F-2

T

T1

isolate BTS from the T1 spans, 3-4
span connection, 5-8

Test data sheets

AMR CDI Alarm Input Verification, A-17

BTS redundancy/alarm tests, A-16

general optimization checklist, A-4

GPS receiver operation, A-5

initial power tests, A-3

LFR receiver operation, A-6

LPA

 convergence, A-8

 IM Reduction, A-7

pre-power tests, A-3

preliminary operations, A-2

RX antenna VSWR, A-17

site checklist, A-2

TX antenna VSWR, A-16

TX BLO

 Offset/Power Output Verification, A-9

 Power Output Verification, A-14

Test Equipment

Automatically Selecting, 3-55

Calibrating, 3-56

Connecting test equipment to the BTS, 3-43

Manually Selecting, 3-54

Reference Chart, 3-44

Selecting, 3-54

verification data sheets, A-1

VSWR, G-1

Test Equipment Setup, 3-43

 GPS & LFR/HZO, 3-34

 HP PCS Interface, F-7

 RF path calibration, 3-67

Test Matrix, C-4

 ATP optimization, C-2

Test Set, Calibration, 3-53

Timing Reference Cables, 1-9

Top Interconnect Plate, 1-19

Troubleshooting

 BBX Control Good – No (or Missing) Span Line Traffic, 6-16

 BLO Calibration Failure, 6-6

 C–CCP Backplane, 6-13, 6-14

 Calibration Audit Failure, 6-7

 Code Domain Power and Noise Floor Measurement Failure, 6-9

 Code Download Failure, 6-4

 Communications Analyzer Communication Failure, 6-3

 CSM Checklist, 6-11

 Data Download Failure, 6-4

 DC Power Problems, 6-18

 Device Enable (INS) Failure, 6-5

 Login Failure, 6-2

 MGLI2 Control Good – No Control over AMR, 6-16

 MGLI2 Control Good – No Control over Co-located GLI2, 6-15

 Miscellaneous Failures, 6-5

 Multi-FER Failure, 6-10

 No BBX Control in the Shelf – No Control over Co-located GLI2s, 6-16

 No DC Input Voltage to any C–CCP Shelf Module, 6-19

 No DC Input Voltage to Power Supply Module, 6-18

 No GLI2 Control through Span Line Connection, 6-15

 No GLI2 Control via LMF, 6-15

 No MCC Channel Elements, 6-17

 Power Meter Communication Failure, 6-2

 Rho and Pilot Time Offset Measurement Failure, 6-8

 Span Problems, no control link, 6-27

 TX and RX Signal Routing, 6-19

 TX Mask Measurement Failure, 6-8

TSU NAM

 Parameters, 3-78

Program, 3-83

TX, antenna VSWR, test data sheets, A-16

TX & RX Path Calibration, 3-63

TX and RX Frequency vs Channel

- 1700 MHz, E-7
- 1900 MHz, E-2
- 800 MHz, E-4

TX and RX Signal Routing, C–CCP Backplane

- Troubleshooting, 6-19

TX Audit Test, 3-71

TX BLO, test data sheets

- Offset/Power Output Verification, A-9
- Power Output Verification, A-14

TX Coupler, Setting Loss Value, 3-62

TX Mask test, 4-6

TX Mask Verification, spectrum analyzer display, illustration, 4-7

TX OUT connection, 4-2

TX Output Acceptance Tests

- Code domain power, 4-5, 4-10
- introduction, 4-5
- Pilot Time Offset, 4-5, 4-9
- Spectral purity TX mask, 4-5, 4-6
- Waveform quality (rho), 4-5, 4-8

TX Path, calibration, 3-64

TX path, 1-4

- audit, 3-71
- calibration, 3-68

U

Updating LMF Files, 5-6

UTP, LMF to BTS connection, 3-5

V

Verification of Test Equipment, data sheets, A-1

Verify Span Parameter Configuration, procedure, 5-3

Voltage Standing Wave Ratio. *See* VSWR

VSWR

- Advantest Test Set, G-4
- Calculation, G-3, G-5
- Equation, G-3, G-5
- manual test setup detail
 - Advantest illustration, G-6
 - HP illustration, G-3, G-4
- required test equipment, G-1
- transmit and receive antenna, G-1

W

Walsh channels, 4-10

Warm-up, 1-6

Waveform Quality (rho), 4-5

Waveform Quality (rho) ATP, 4-8

When to optimize

- Ancillary – table, C-1
- BTS, C-1
- inter-frame cabling, C-2

X

Xircom Model PE3–10B2, LMF to BTS connection, 3-5