

# Chapter 7: Optimization and Optional Acceptance Test Procedures (ATP)

## Table of Contents

---

ATP Overview .....	7-1
Overview .....	7-1
BTS Preparation .....	7-2
Overview .....	7-2
Required Tools and Equipment .....	7-2
Procedure to Remove the Solar Cover .....	7-2
BTS Power Up .....	7-2
Procedure to Remove Diagnostic Access Cover .....	7-4
Connect LMF to BTS .....	7-6
Overview .....	7-6
LMF to BTS Connection .....	7-6
Procedure to Connect LMF to BTS via Serial Port Connection .....	7-6
Procedure to Connect LMF to BTS via Ethernet Connection .....	7-7
Connect Test Equipment to BTS .....	7-10
Overview .....	7-10
Procedure to Connect Advantest R3465 to BTS .....	7-11
Procedure to Connect Advantest R3267 to BTS .....	7-13
Procedure to Connect the Motorola CyberTest, HP 8935, and HP 8921 to BTS .....	7-15
Procedure to Connect the Agilent E4406A/E4432B to BTS .....	7-16
Connect Test Set and Power Meter to LMF .....	7-18
Procedure to Connect the Communication Test Set and Power Meter to the LMF .....	7-18
RS232 Cable Configuration .....	7-19
BTS Configuration .....	7-20
Objective .....	7-20
Procedure to Create a Named HyperTerminal Connection for MMI Communication .....	7-20
Procedure to Establish an MMI Communication Session .....	7-22
Procedure to Set IP Address .....	7-23
Procedure to Simulate an LMF Session .....	7-24
Updating Default Channel Setting to Customer Operating Channel .....	7-25
Synchronization Background .....	7-26
Procedure to Verify and Change BTS Synchronization Mode .....	7-27
Procedure to Verify DPLL Tracking (RGPS/HSO) .....	7-28
Procedure to Verify and Modify Default Location Coordinates .....	7-29

---

## Table of Contents – continued

Procedure to Set Frame ID for Multi–Unit Logical BTS Configuration	7-31
BTS Software	7-32
Objective	7-32
Install the LMF Program and BTS Binaries	7-32
Create a Site–Specific BTS Directory	7-32
Start the LMF and Login to the BTS	7-32
Update BTS Specific CDF File Device Load Version	7-33
Download/Enable MAWI	7-34
Configuration Data File (CDF)	7-35
System Status LED States	7-36
Verify and Set Span Line Settings	7-37
Objective	7-37
Span Line Settings	7-37
Procedure to Verify and Set Span Line Settings	7-37
SPAN_CONFIG Parameters	7-39
GPIB Addresses	7-40
Introduction	7-40
Verify the Gigatronics 8541C Power Meter GPIB Address	7-40
Verify and Set Motorola CyberTest GPIB Address	7-41
Verify and Set HP8935 Test Set GPIB Address	7-42
Verify and Set the HP8921A and HP83236A/B GPIB Addresses	7-43
Verify and Set Advantest R3465 GPIB Address	7-44
RS232 GPIB Interface Box	7-45
Verify and Set Advantest R3267 GPIB Address	7-45
Verify and Set Advantest R3562 Signal Generator GPIB Address	7-47
Verify and Set Agilent E4406A Transmitter Tester GPIB Address	7-47
Verify and Set Agilent E4432B Signal Generator GPIB Address	7-49
Test Equipment Calibration	7-51
Background	7-51
Procedure to Calibrate Test Equipment	7-52
Calibration Without the LMF	7-52
Procedure to Calibrate R3465 Test Set	7-53
Procedure to Calibrate R3267 Test Set	7-53
Procedure to Calibrate Agilent E4406A	7-54
Procedure to Setup Advantest R3465 Test Equipment	7-55
Procedure to Setup Advantest R3267 Test Equipment	7-56
Test Equipment Selection	7-57
Objective	7-57
Prerequisites	7-57
Procedure to Select Test Equipment	7-57
Selecting Test Equipment Automatically or Manually	7-58
Procedure to Manually Select Test Equipment in a Serial Connection Tab	7-58
Procedure to Automatically Select Test Equipment in a Serial Connection Tab	7-59
Power Meter Calibration	7-60

---

## Table of Contents – continued

Objective .....	7-60
Prerequisites .....	7-60
Procedure to Calibrate the Power Meter .....	7-60
Test Cable Calibration .....	7-61
Background .....	7-61
Purpose of Cable Calibration .....	7-61
Procedure to do an Automated Cable Calibration .....	7-62
Create CAL File .....	7-65
Objective .....	7-65
Background .....	7-65
Procedure to Create a CAL File .....	7-66
Acceptance Tests .....	7-67
Overview .....	7-67
TX Test Objective .....	7-67
TX Tests .....	7-67
RX Test Objective .....	7-68
RX Tests .....	7-68
Subscriber Unit (SU) Test and Setup .....	7-69
Objective .....	7-69
Background .....	7-69
Procedure to Test and Verify SU .....	7-69
Procedure to Program SU NAM Parameters .....	7-71
CDMA Operating Frequency Programming Information – North American Cellular Bands .....	7-73
Objective .....	7-73
1900 MHz PCS Channels .....	7-73
Calculating 1900 MHz Center Frequencies .....	7-74
800 MHz CDMA Channels .....	7-76
Calculating 800 MHz Center Frequencies .....	7-76
TX Acceptance Tests .....	7-78
Objective .....	7-78
Prerequisites .....	7-78
Procedure to Run TX ATP Test .....	7-78
Procedure to Run TX Tests Using Backup Synchronization (Sites Equipped With GPS) .....	7-78
RX Acceptance Tests .....	7-84
Objective .....	7-84
Prerequisites .....	7-84
Procedure to Run RX ATP Test .....	7-84
Generate an ATP Report .....	7-88
Background .....	7-88
ATP Report .....	7-88
Procedure to Run ATP Report .....	7-88
Copy LMF CAL File to CBSC .....	7-89
Objective .....	7-89

---

## Table of Contents – continued

Background .....	7-89
Procedure to Copy CAL Files from LMF to a Diskette .....	7-89
Procedure to Copy CAL Files from Diskette to the CBSC .....	7-90
Prepare to Leave the Site .....	7-91
Remove External Test Equipment .....	7-91
Reset and Initialize Site Remotely .....	7-91
Bring BTS into Service with the CDMA LMF .....	7-91
Terminate LMF Session/Remove Terminal .....	7-92
Replace Diagnostic Access Cover .....	7-93
Replace Solar Cover .....	7-93

---

# ATP Overview

## Overview

The purpose of this procedure is to outline the optimization and ATP after a BTS installation. Calibration of the BTS is performed in the factory and is not required. The ATP is also performed in the factory and is optional.

All the procedures in this chapter are to be performed with the BTS out of service or under LMF control. If necessary, refer to the “Shut Down and Restoring BTS Signaling” procedure in Chapter 7.

For a complete listing of the required tools and equipment, refer to the “ATP Tools and Equipment” list in Chapter 1.



### IMPORTANT

You must run the ATP with LMF Software Release 2.15.0.1.10 or higher.

# BTS Preparation

## Overview

The purpose of this procedure is to prepare the BTS for the ATP. This procedure consists of:

1. Solar Cover Removal
2. BTS Power Up
3. Diagnostic Access Cover Removal

## Required Tools and Equipment

The following tools and materials are necessary to do this procedure:

- Torque driver wrench, 1/4-in. hex female drive, 0–10 N–M
- T20 Torx tamper bit

## Procedure to Remove the Solar Cover

If you did not mount the solar cover during the unit installation, then this procedure is not necessary.

Remove the four captive screws (two on each side) that hold the front solar cover. Refer to Figure 7-1.

**Figure 7-1:** Front Solar Cover

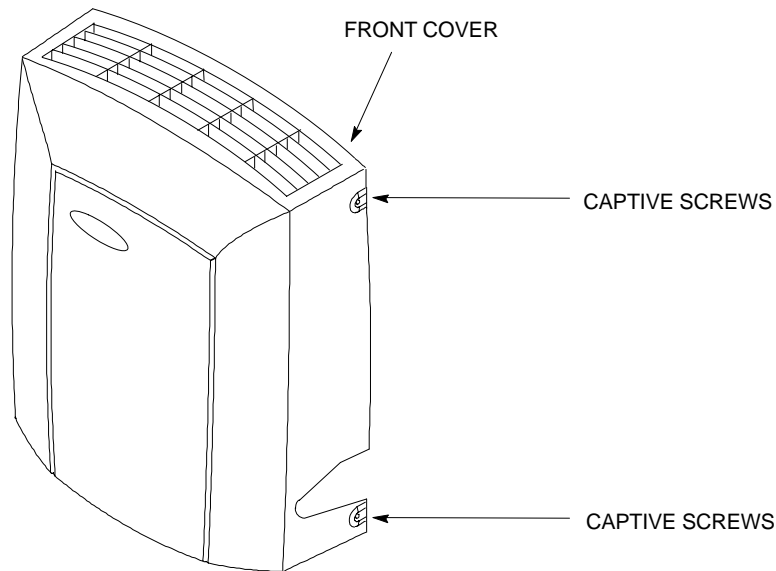

## BTS Power Up

Figure 7-2 shows the location of the AC power breakers inside the optional Primary Surge Suppressor. The AC breakers must be closed before you power up the MicroCell unit.

Figure 7-3 shows the location of the AC and DC Power breakers on the unit. Push both the AC and DC breakers in to power up the unit.

Figure 7-2: Location of AC Power Breakers Inside Primary Surge Suppressor

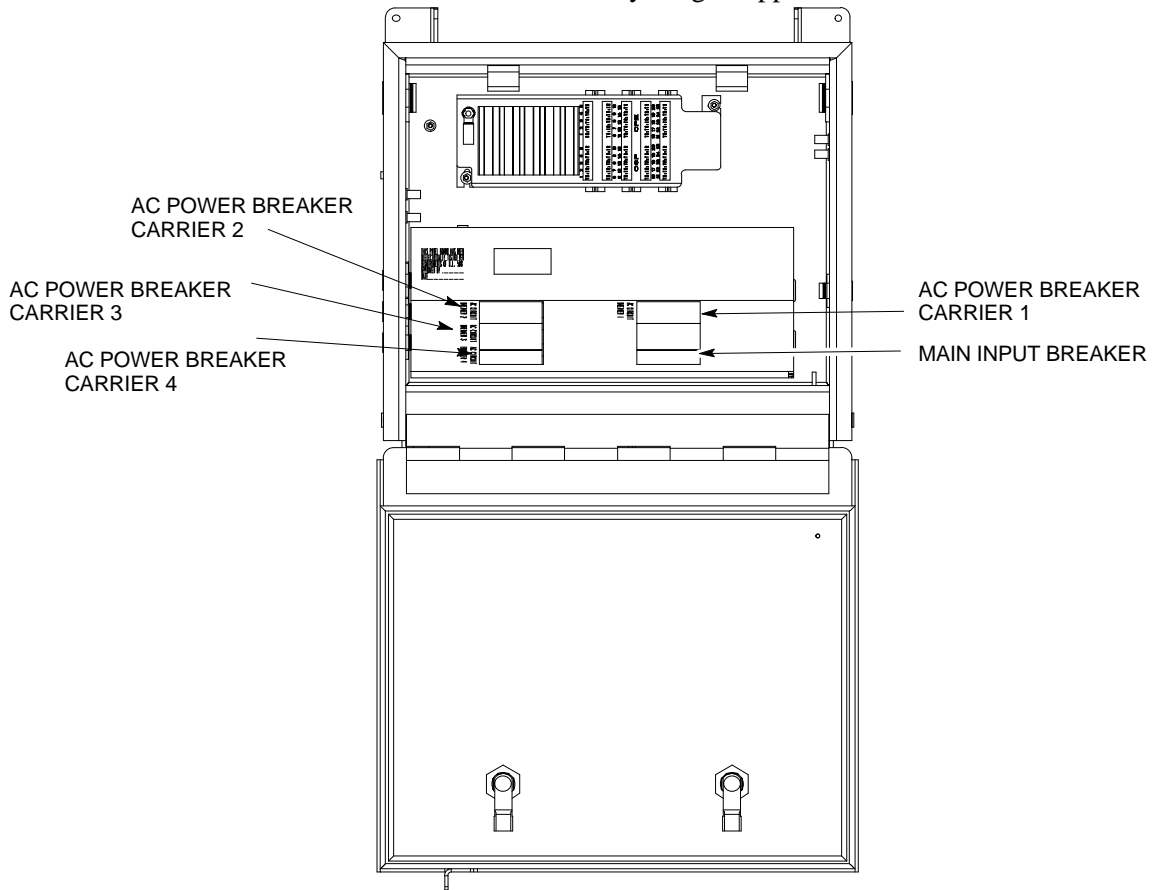
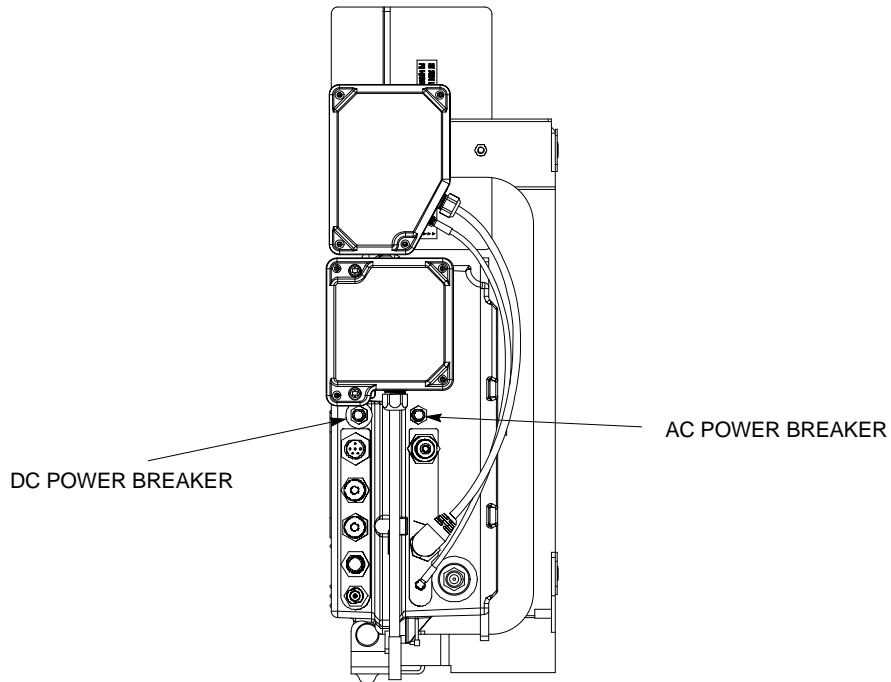

Figure 7-3: Location of AC and DC Power Breakers



## BTS Preparation – continued

### Procedure to Remove Diagnostic Access Cover

#### NOTE

The screws are captivated. Do not attempt to remove them from the cover.

**Table 7-1:** Procedure for Removing Diagnostic Access Cover

Step	Action
1	Using a T20 Torx tamper bit, loosen the two tamper resistant M4 screws holding the cover. See Figure 7-4.
2	Gently tap the cover to loosen if required.
3	Remove the cover and set inside a secure place.
	<b>NOTE</b> The 19 MHz and 2 SEC connectors should not be terminated with a 50 ohm terminator.

**Figure 7-4:** How To Remove The Diagnostic Access Cover

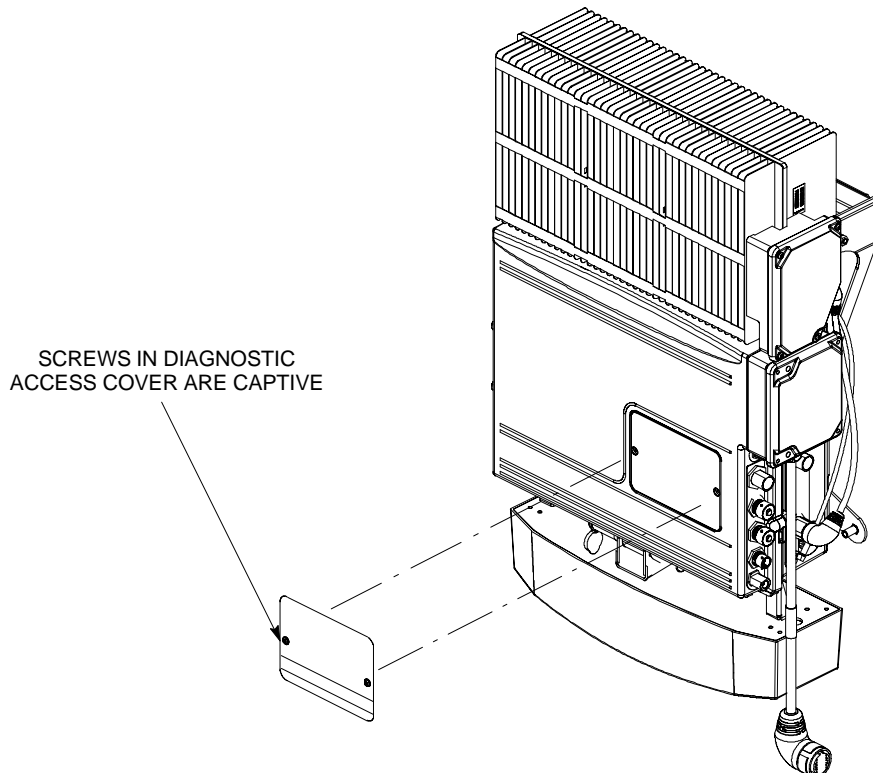
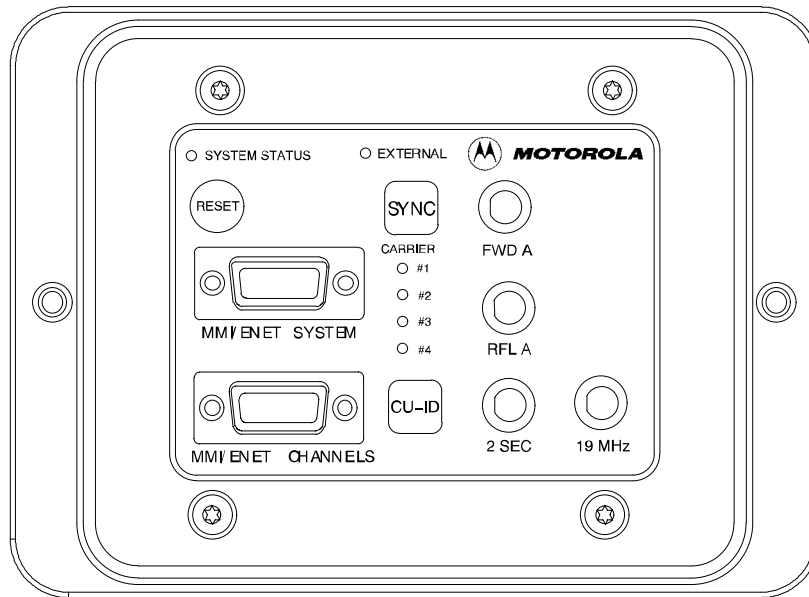



Figure 7-5: Detail Location of the Diagnostic Access Area



# Connect LMF to BTS

## Overview

This procedure gives instructions to connect the LMF to the BTS.

## LMF to BTS Connection

The LMF is connected to the MMI/LMF connector on the diagnostic access area.

The LMF serial port, or PCMCIA (Personal Computer Memory Card International Association) Serial Adapter provides the connection between the LMF and the MMI/LMF connector located on the diagnostic access area.

There are three different methods to connect the LMF to the BTS: serial port to DB9, Ethernet via Ethernet hub, and Ethernet via crossover connection.

## Procedure to Connect LMF to BTS via Serial Port Connection

Connect the LMF to the BTS. Refer to Figure 7-6, Figure 7-10, and Table 7-2.

Figure 7-6: Serial to DB9 BTS to LMF connection

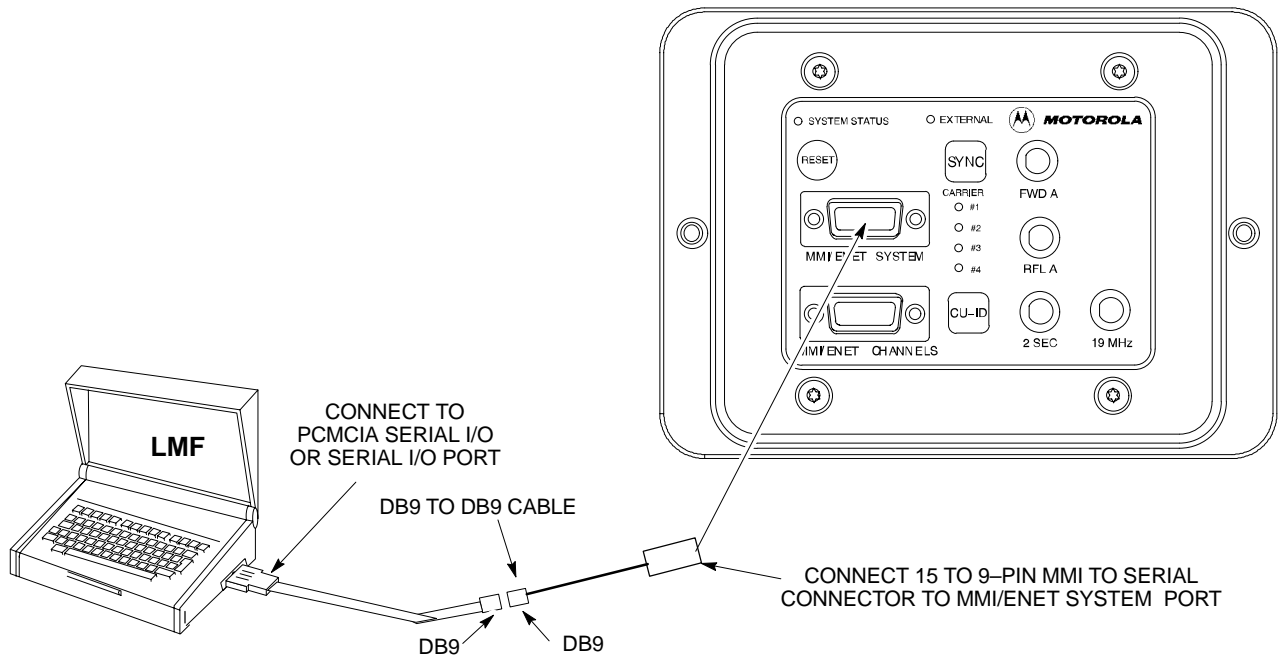

7

## Connect LMF to BTS – continued

### Procedure to Connect LMF to BTS via Ethernet Connection

You can connect the LMF to the BTS via an Ethernet connection. Depending upon site configuration, you can use an Ethernet connection with or without an Ethernet hub. For example, if your BTS is mounted on a pole and there is no power connection available for the Ethernet hub, then you can connect to the BTS via a RJ45 crossover cable or a MMI to LAN crossover adapter. In either case, you must configure either the RJ45 cable or the adapter to a crossover configuration.

#### Ethernet connection via Ethernet hub

To connect the LMF to the BTS via an Ethernet connection using an Ethernet hub, refer to Figure 7-7, Figure 7-10, and Table 7-2.

**Figure 7-7:** Ethernet BTS to LMF Connection Using an Ethernet Hub

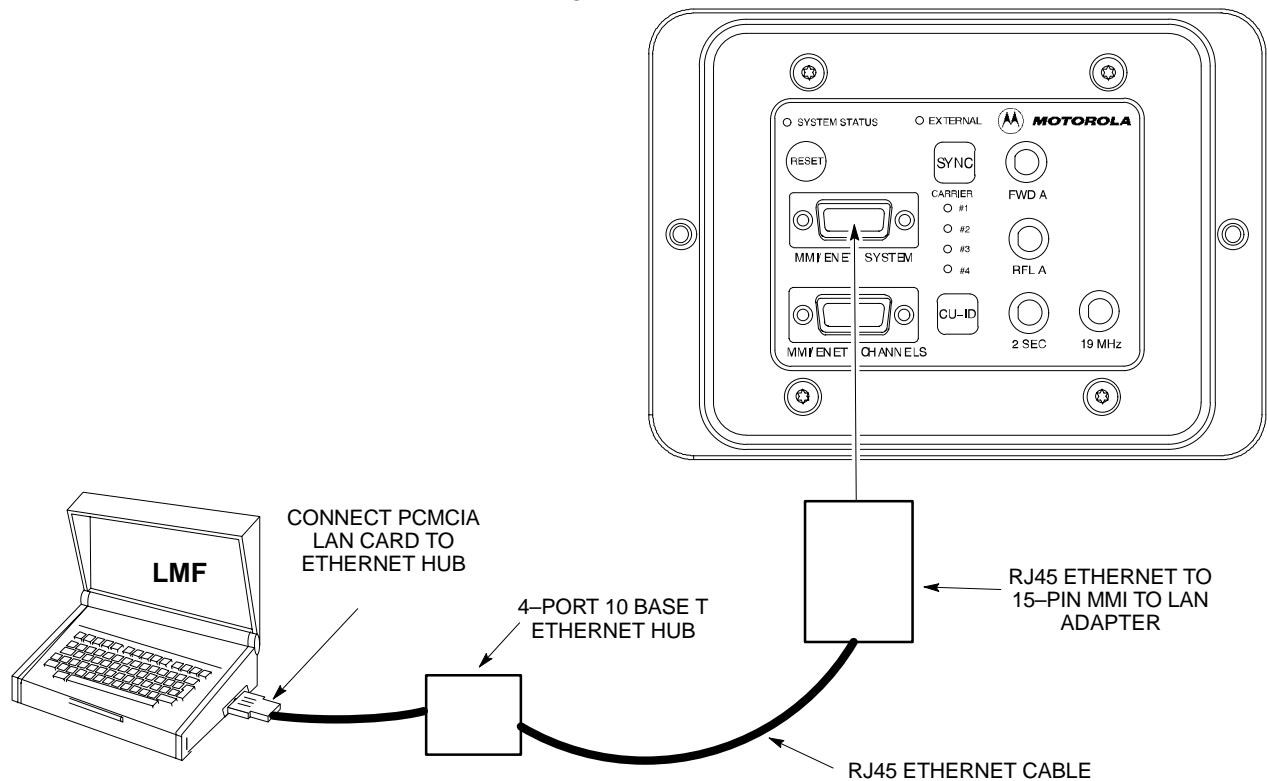

#### Ethernet connection via crossover cable

To connect the LMF to the BTS via an Ethernet connection using a crossover cable or adapter, you must configure the RJ45 cable or the MMI to LAN adapter as a crossover. Refer to Figure 7-8 for information on how to configure the cable or adapter. Refer to Figure 7-9, Figure 7-10, and Table 7-2 to connect the LMF to the BTS.

# Connect LMF to BTS – continued

**Figure 7-8:** Ethernet Crossover Cable and Adapter Wiring

**RJ45 ETHERNET CABLE CROSSOVER CONFIGURATION**

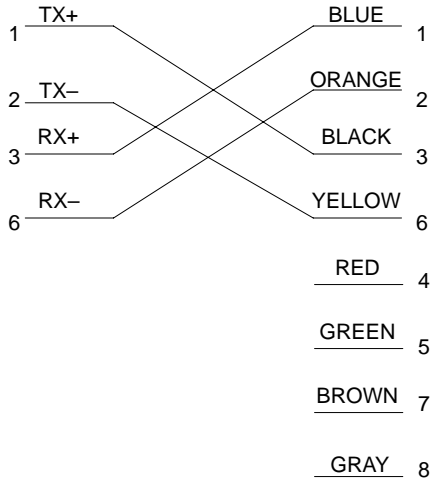

**MMI/LAN ADAPTER CROSSOVER CONFIGURATION**

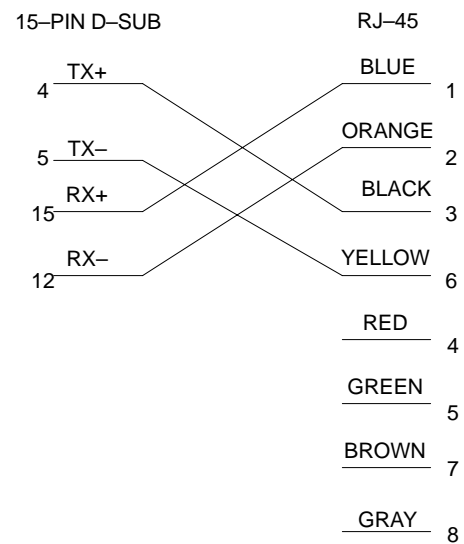

**Figure 7-9:** Ethernet BTS to LMF Connection Using Crossover Cable or Adapter

**NOTE:** YOU MUST CONFIGURE EITHER THE RJ45 CABLE OR THE MMI TO LAN ADAPTER AS A CROSSOVER TO CONNECT THE LMF TO THE BTS IN THIS FASHION.

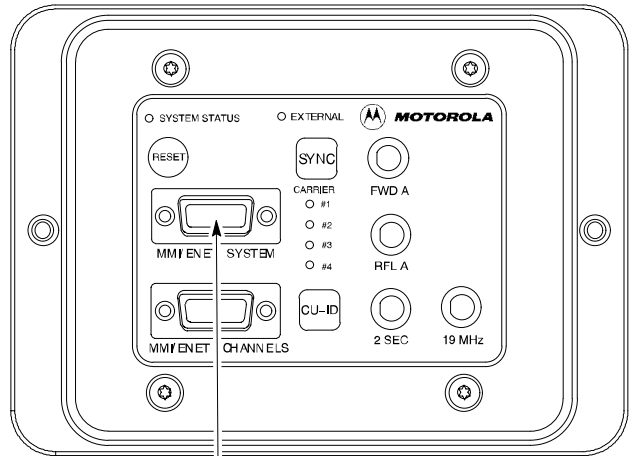

7

**MMI/LMF serial connector information**

Refer to Figure 7-10 and Table 7-2 for information for the 15-pin MMI/LMF connector.

**Figure 7-10:** 15-Pin MMI/LMF Serial Connector

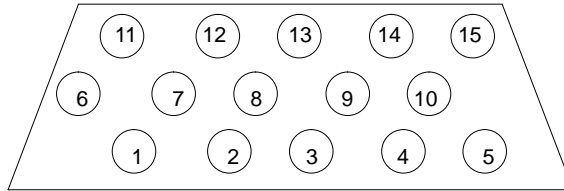

**Table 7-2: 15-Pin MMI/LMF Serial Cable Information**

Pin#	Abbreviation	Description
1	RTS	Request to Send
2	TXD	Transmit Data
3	RXD	Receive Data
4	TX+	Ethernet Transmit +
5	TX-	Ethernet Transmit -
6	CTS	Clear to Send
7	CTS	Clear to Send
8	CTS	Clear to Send
9	-	Open
10	RI	Ring Indicator
11	RI	Ring Indicator
12	RX+	Ethernet Receive +
13	CTS	Clear to Send
14	GND	Ground
15	RX-	Ethernet Receive -

---

# Connect Test Equipment to BTS

## Overview

The following test equipment setup applies to the BTS Acceptance Test Procedure (ATP).

The SC™ 300 BTS supports the following test sets for IS95 A/B testing:

1. Advantest R3465 with R3561 Signal Generator.
2. Motorola CyberTest
3. HP 8921A (for 800 MHz testing only)
4. Agilent 8935 Series E6380A (formally HP8935)

The 1X SC™ 300 BTS supports the following test sets for CDMA2000 1X testing:

1. Advantest R3267 with R3562 Signal Generator
2. Agilent E4406A with E4432B Signal Generator

### NOTE

If you are not going to perform the ATP, then proceed to the “Creating a Named HyperTerminal Connection for MMI Communication” procedure in this chapter.

## Equipment warm-up



### IMPORTANT

Warm-up **BTS equipment** site for a minimum of 60 minutes prior to the BTS ATP. This assures BTS site stability and contributes to test accuracy. (Time spent running initial power-up, hardware/firmware audit, and BTS download counts as warm-up time).



### IMPORTANT

Warm-up **test equipment** for a minimum of 60 minutes prior to their use in the BTS ATP. This assures maximum equipment measurement accuracy and consistency during testing.

All test equipment is controlled by the LMF via a Serial Cable/GPIB bus. The LMF expects each piece of test equipment to have a factory-set GPIB address. If there is a communications problem between the LMF and any piece of test equipment, you should verify that the GPIB addresses have been set correctly.

## Connect Test Equipment to BTS – continued

### NOTE

In the following procedure and illustrations, typical DIP switch positions and/or configurations are shown. If required, refer to the test equipment OEM user manuals for additional information.

### Procedure to Connect Advantest R3465 to BTS

Follow the procedure in Table 7-3 to connect the Advantest R3465 to the BTS. Refer to Figure 7-11.

**Table 7-3:** Connecting Advantest R3465 to the BTS

Step	Action
1	Connect an SMA/BNC coax cable between the following points: <ul style="list-style-type: none"><li>– BNC on the Advantest <b>CDMA TIMEBASE IN</b> port.</li><li>– SMA on the 19 MHz port on the diagnostic access area of the BTS.</li></ul>
2	Connect an SMA/BNC cable between the following points: <ul style="list-style-type: none"><li>– BNC to one end of the BNC “T.”</li><li>– SMA on the 2 Sec port on the diagnostic access area of the BTS.</li></ul>
3	Connect a BNC/BNC cable between the following points: <ul style="list-style-type: none"><li>– BNC to one end of the BNC “T.”</li><li>– BNC to the <b>EXT TRIG</b> port on the rear panel of the Advantest R3465.</li></ul>
4	Connect the BNC “T” to the <b>EVEN SEC/SYNC IN</b> port of the Advantest R356IL.
5	Verify the R3561 and R3465 rear panel connections are in place ( <i>These are common connections and should already be installed</i> ): <ul style="list-style-type: none"><li>– Serial cable between 3465A rear panel <b>SERIAL I/O</b> port and R3561 <b>SERIAL I/O</b> port.</li><li>– SMA cable between 3465A rear panel <b>1ST LO OUT</b> port and R3561 <b>LOCAL IN</b> port.</li></ul>

# Connect Test Equipment to BTS – continued

**Figure 7-11:** Communications Test Set Timing Signal Detail (Advantest R3465)

CONNECTIONS DEPICTED BY HEAVY BOLD LINES ARE STATIONARY AND SHOULD REMAIN INSTALLED DURING TEST EQUIPMENT TRANSPORT FROM SITE TO SITE.

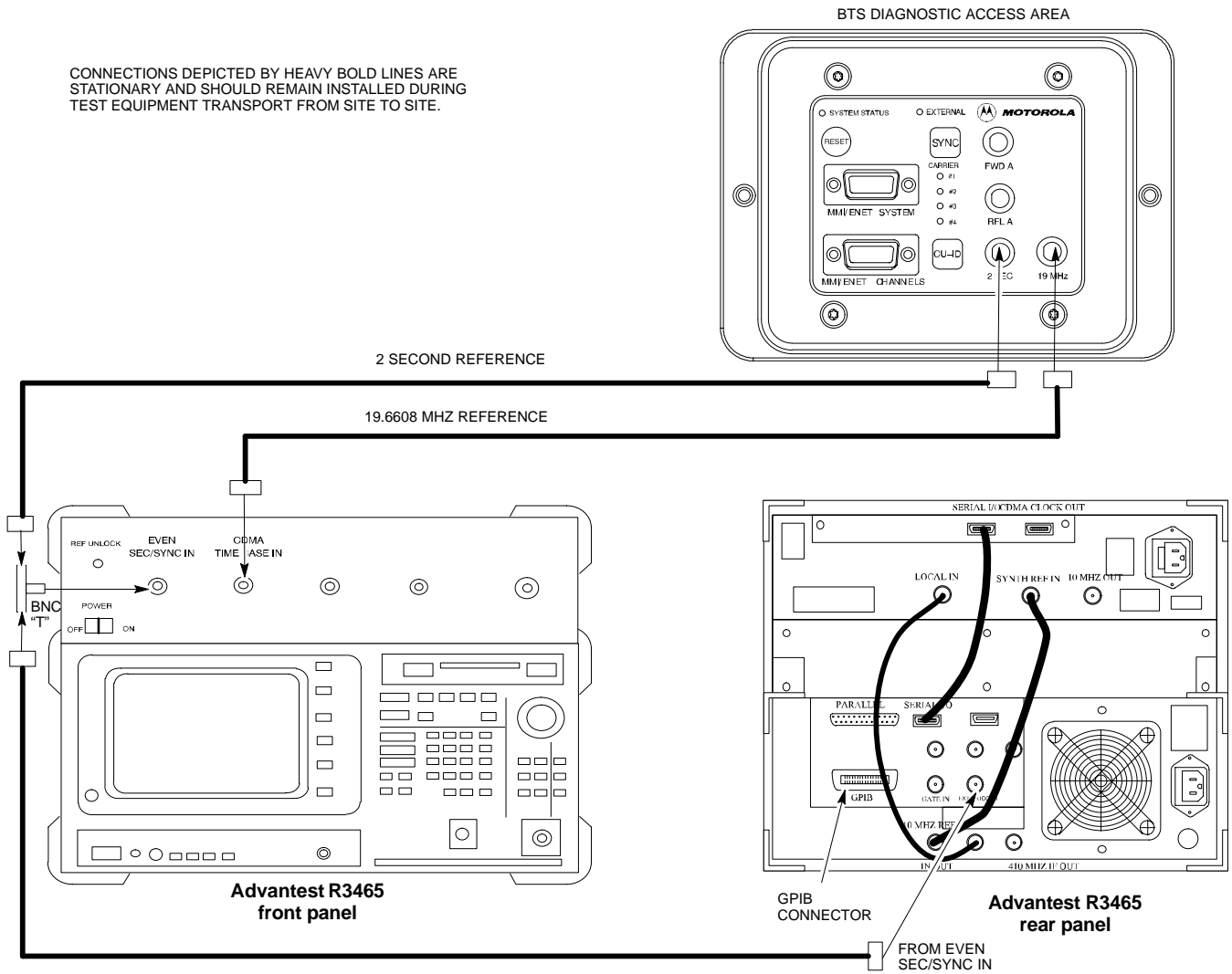

7



## Connect Test Equipment to BTS – continued

### Procedure to Connect Advantest R3267 to BTS

Use the procedures in Table 7-4 to connect the Advantest R3267 to the BTS. Refer to Figure 7-12.

#### NOTE

The Advantest R3267 test set is used for 1X system testing.

**Table 7-4:** Procedure to Connect Advantest R3267 to the BTS

Step	Action
1	Connect an SMA/BNC coax cable between the following points: <ul style="list-style-type: none"><li>– BNC on the <b>MOD TIMEBASE IN</b> port on the front panel of the Advantest R3562 Test Source.</li><li>– SMA on the 19 MHz port on the diagnostic access area of the BTS.</li></ul>
2	Connect an SMA/BNC cable between the following points: <ul style="list-style-type: none"><li>– SMA on the 2 Sec port on the diagnostic access area of the BTS.</li><li>– BNC to the <b>EXT TRIG IN</b> port on the front panel of the Advantest R3562 Test Source.</li></ul>
3	Verify the R3267 and R3562 rear panel connections are in place ( <i>These are common connections and should already be installed</i> ): <ul style="list-style-type: none"><li>– Serial cable between R3267 rear panel <b>SERIAL I/O</b> port and R3562 rear panel <b>SERIAL I/O</b> port.</li><li>– SMA cable between R3267 rear panel <b>10MHZ REF OUT</b> port and R3562 rear panel <b>SYNTHE REF IN</b> port.</li><li>– SMA cable between R3267 rear panel <b>EXT TRIG</b> port and R3562 rear panel <b>CLOCK OUT 1</b> port.</li><li>– Parallel cable between R3267 rear panel <b>GPIB</b> port and R3562 <b>GPIB</b> port.</li></ul>

# Connect Test Equipment to BTS – continued

**Figure 7-12: R3267 Communications Test Set Timing Signal Detail**

CONNECTIONS DEPICTED BY HEAVY BOLD LINES ARE STATIONARY AND SHOULD REMAIN INSTALLED DURING TEST EQUIPMENT TRANSPORT FROM SITE TO SITE.

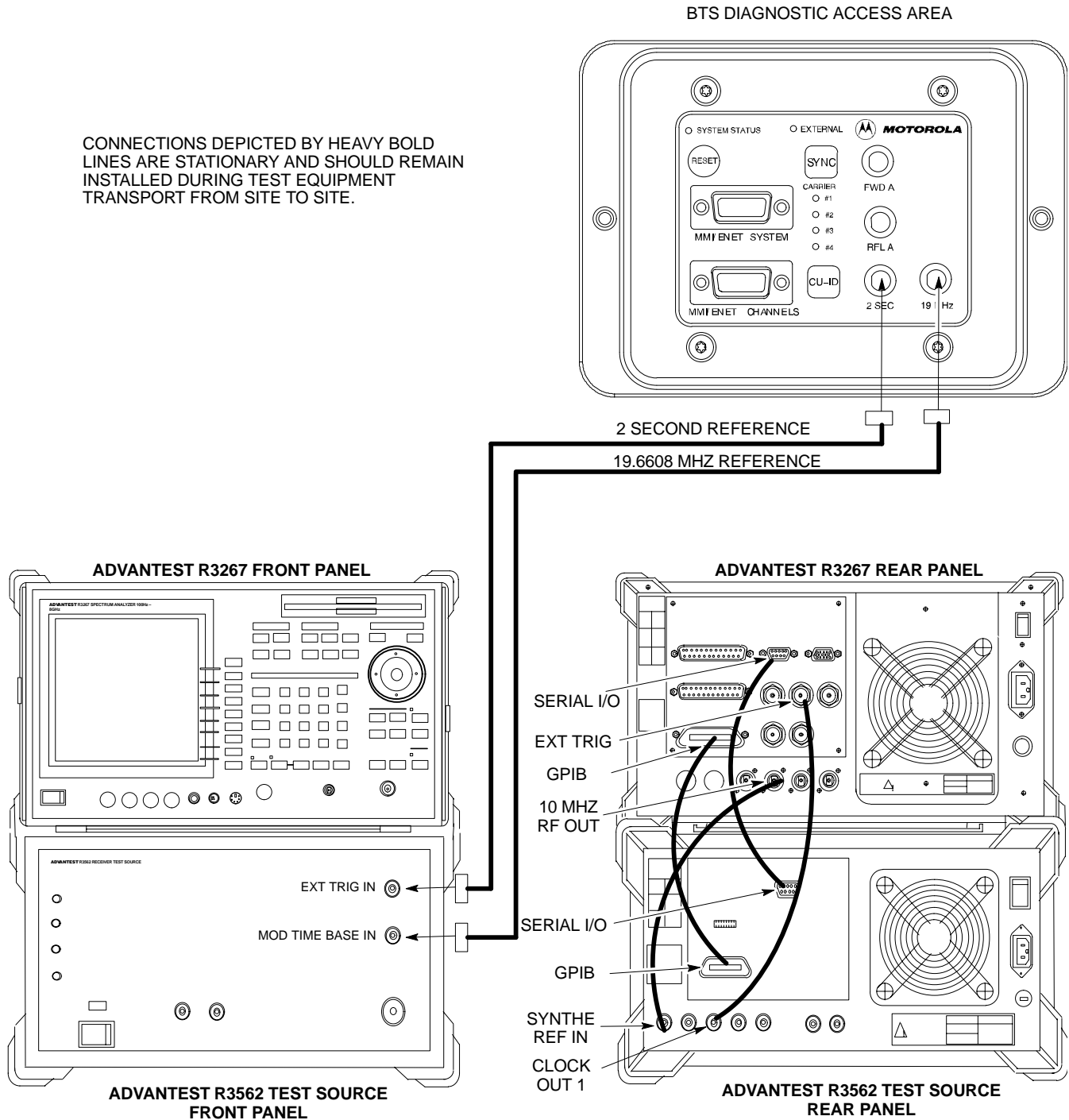

7

# Connect Test Equipment to BTS – continued

## Procedure to Connect the Motorola CyberTest, HP 8935, and HP 8921 to BTS

Figure 7-13: Communications Test Set Timing Signal Detail (CyberTest, HP 8935, and HP 8921)

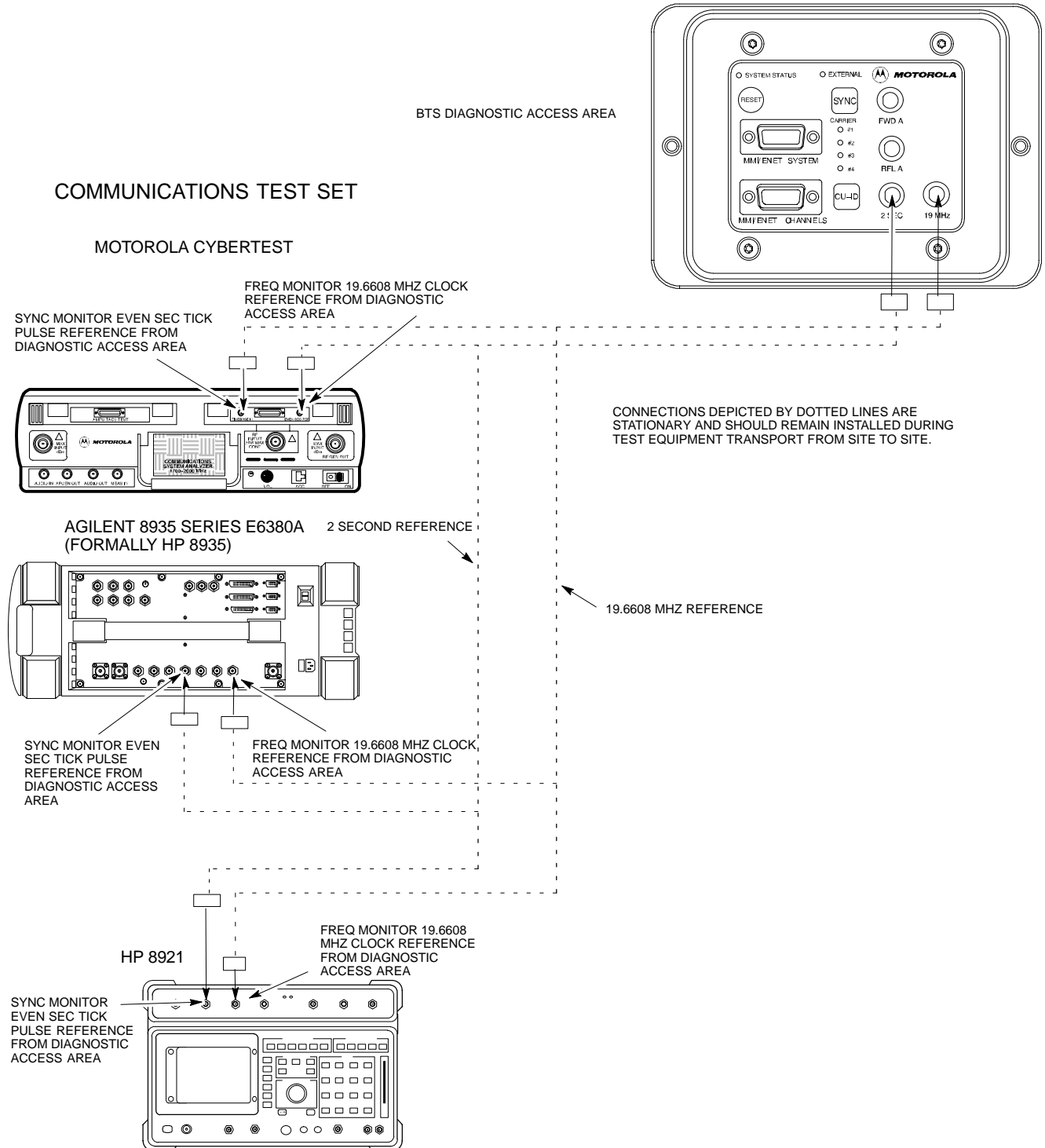

**Procedure to Connect the  
Agilent E4406A/E4432B to BTS**

**Agilent E4406A/E4432B test equipment interconnection**

To provide proper operation during testing when both units are required, the 10 MHz reference signal from the E4406A transmitter test set must be provided to the E4432B signal generator. Connect a BNC (M)–BNC (M) cable from the E4406A **10 MHz OUT (SWITCHED)** connector to the E4432B **10MHz IN** connector as shown in Figure 7-14.

**Figure 7-14:** Agilent 10 MHz Reference Connections

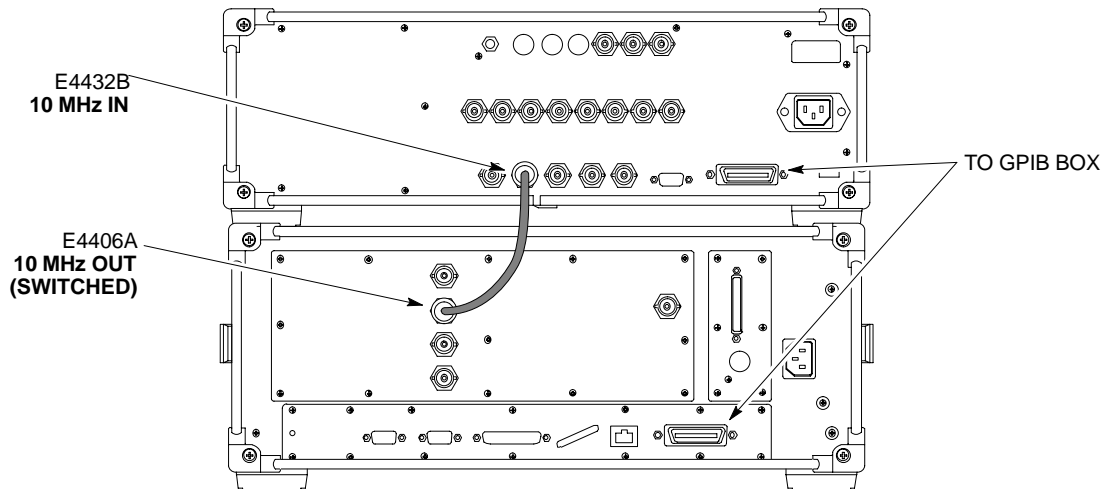

# Connect Test Equipment to BTS – continued

**Figure 7-15: Agilent E4406A/E4432B Communications Test Set Timing Signal Detail**

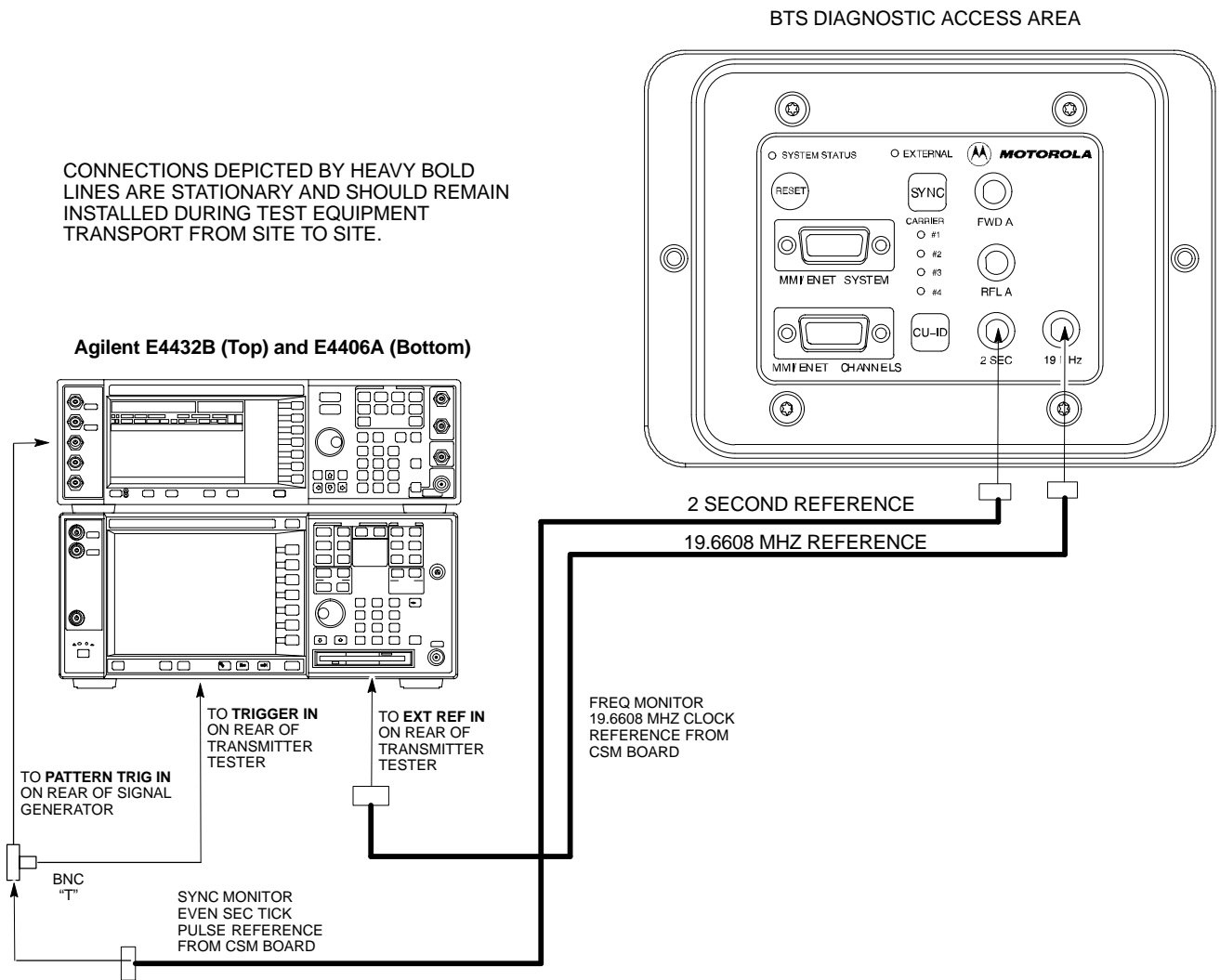

**NOTE:**

10 MHZ IN ON REAR OF SIGNAL GENERATOR IS CONNECTED TO 10 MHZ OUT (SWITCHED) ON REAR OF TRANSMITTER TESTER (FIGURE 7-14).

# Connect Test Set and Power Meter to LMF

## Procedure to Connect the Communication Test Set and Power Meter to the LMF

Use the following procedure in Table 7-5 to connect the communication test set to the power meter and to the LMF. Refer to Figure 7-16.

Step	Action
1	Connect the RS232–IEEE488 converter serial cable between the COM1 port of the LMF and the RS232 port of the RS232–IEEE488 converter.
2	Connect a GPIB cable between the RS232–IEEE488 converter and the GPIB port on the communication test set.
3	Connect a GPIB cable between the GPIB port on the communication test set and the GPIB port of the power meter.
4	Set the DIP switches on the RS232–IEEE488 converter as shown in Figure 7-16.
5	Power on the communication test set, power meter and RS232–IEEE488 converter.

**Figure 7-16:** LMF to Test Equipment Connection

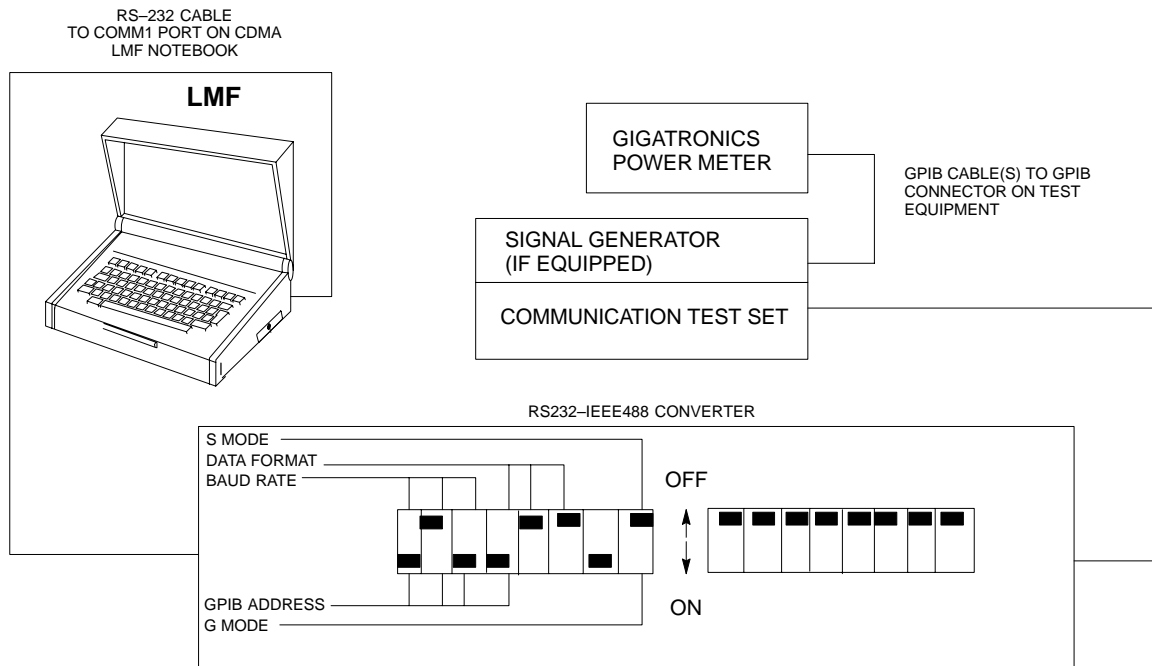

7

**RS232 Cable Configuration**

One National Instruments GPIB-232-CT with Motorola CGDSEDN04X RS232 serial cable or equivalent is used to interface the LMF to the test equipment.

A Standard RS-232 cable can be used with the following modifications:

- Pin 8 (CTS) does not have to be jumpered/shorted to the others as it is a driver output. The DTR is already a driver output signal. The other pins are to receivers. Short pins 7, 1, 4, 6 on each cable end:

Figure 7-17 shows the cable configuration for the RS232-IEEE488 converter serial cable.

**Figure 7-17:** RS232-IEEE488 Converter Serial Cable Configuration

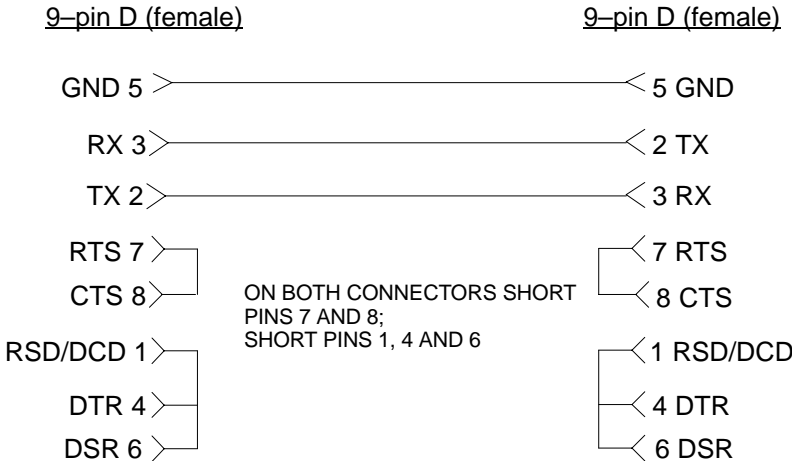

# BTS Configuration

## Objective

The objective of this procedure is to configure the BTS and establish communication sessions between the LMF and BTS. This procedure consists of:

1. Creating a named hyperterminal connection for MMI communication
2. Establishing an MMI communication session
3. Verify and set IP address
4. Programming customer operating channel
5. Verifying BTS synchronization mode
6. Verifying DPLL tracking
7. Setting frame\_id

## Procedure to Create a Named HyperTerminal Connection for MMI Communication

Confirming or changing the configuration data of certain BTS Field Replaceable Units (FRU) requires establishing an MMI communication session between the CDMA LMF computer and the FRU. Using features of the Windows operating system, the connection properties for an MMI session can be saved on the CDMA LMF computer as a named Windows HyperTerminal connection. This eliminates the need for setting up connection parameters each time an MMI session is required to support optimization.

Once the named connection is saved, a shortcut for it can be created on the Windows desktop. Double-clicking the shortcut icon will start the connection without the need to negotiate multiple menu levels.

Follow the procedures in Table 7-6 to establish a named HyperTerminal connection and create a Windows desktop shortcut for it.

**Table 7-6:** Procedure to Create a Named HyperTerminal Connection for MMI Communication

Step	Action
1	From the Windows Start menu, select: <b>Programs &gt; Accessories</b>
2	Select <b>Communications</b> , double click the <b>Hyperterminal</b> folder, and then double click on the <b>Hypertrm.exe</b> icon in the window which opens. <b>NOTE</b> <ul style="list-style-type: none"><li>• If a <b>Location Information Window</b> appears, enter the required information, then click on the <b>Close</b> button. (This is required the first time, even if a modem is not to be used.)</li><li>• If a <b>You need to install a modem.....</b> message appears, click on <b>NO</b>.</li></ul>
. . . continued on next page	



**Table 7-6:** Procedure to Create a Named HyperTerminal Connection for MMI Communication

Step	Action
3	When the <b>Connection Description</b> box opens: <ul style="list-style-type: none"> <li>– Type a name for the connection being defined (e.g., MMI Session) in the <b>Name:</b> window,</li> <li>– Highlight any icon preferred for the named connection in the <b>Icon:</b> chooser window, and</li> <li>– Click <b>OK</b>.</li> </ul>
	<p><b>NOTE</b></p> <p>For CDMA LMF computer configurations where COM1 is used by another interface such as test equipment and a physical port is available for COM2, select COM2 in the following step to prevent conflicts.</p>
4	From the <b>Connect using:</b> pick list in the <b>Connect To</b> box displayed, select <b>Direct to Com 1</b> or <b>Direct to Com 2</b> for the RS–232 connection port, and click <b>OK</b> .
5	In the <b>Port Settings</b> tab of the <b>COM# Properties</b> window displayed, configure the RS–232 port settings as follows: <ul style="list-style-type: none"> <li>• Bits per second: 9600</li> <li>• Data bits: 8</li> <li>• Parity: None</li> <li>• Stop bits: 1</li> <li>• Flow control: None</li> </ul>
6	Click <b>OK</b> .
7	Save the defined connection by selecting: <b>File &gt; Save</b>
8	Close the HyperTerminal window by selecting: <b>File &gt; Exit</b>
9	Click the <b>Yes</b> button to disconnect when prompted.
10	If the <b>Hyperterminal folder</b> window is still open, proceed to step 12.
11	Select <b>Communications</b> and double click the <b>Hyperterminal</b> folder.
12	Highlight the newly–created connection icon by clicking on it.
13	<i>Right click and drag</i> the highlighted connection icon to the Windows desktop and release the right mouse button.
14	From the popup menu which appears, select <b>Create Shortcut(s) Here</b> .
15	If desired, reposition the shortcut icon for the new connection by dragging it to another location on the Windows desktop.
16	Close the <b>Hyperterminal folder</b> window by selecting: <b>File &gt; Close</b>

**Procedure to Establish an MMI Communication Session**

For those procedures which require MMI communication between the CDMA LMF and the BTS, follow the procedures in Table 7-7 to initiate the communication session.

**NOTE**

If an LMF session is in progress, logout of the LMF prior to establishing an MMI communication session. Refer to steps 1 and 2 of the “Remove LMF” procedure in Table 7-54.

**Table 7-7:** Procedure to Establish an MMI Communication Session

Step	Action
1	Connect the CDMA LMF computer to the BTS. Refer to the “Connecting the LMF to the BTS” procedure in this chapter.
2	Start the named HyperTerminal connection for MMI sessions by double clicking on its Windows desktop shortcut.
3	<p><b>NOTE</b></p> <p>If a Windows desktop shortcut was not created for the MMI connection, access the connection from the Windows Start menu by selecting:</p> <p><b>Programs &gt; Accessories &gt; Hyperterminal &gt; HyperTerminal &gt; &lt;Named HyperTerminal Connection (e.g., MMI Session)&gt;</b></p> <p>Once the connection window opens, establish MMI communication with the BTS FRU by pressing the CDMA LMF computer Enter key until the prompt identified in the applicable procedure is obtained.</p> <p>Every command is entered at the SC300&gt; prompt unless otherwise specified.</p>

## BTS Configuration – continued

### Procedure to Set IP Address

You must set an IP address on the unit before you can begin an LMF Ethernet (LAN) session. Follow the instructions in Table 7-8 to set the IP address.

**Table 7-8:** Procedure to Set IP Address

Step	Action
1	<p>Enter the following command to check the ethernet IP address:</p> <pre>sc300&gt;<b>ether getip</b></pre> <p>Observe the following typical response (if the IP address was not set):</p> <pre>COMMAND ACCEPTED: ether getip Current IP ADDRESS: 0.0.0.0</pre>
2	<p>Enter the following command to check the ethernet gateway address:</p> <pre>sc300&gt;<b>ether getgw</b></pre> <p>Observe the following typical response (if the IP address was not set):</p> <pre>COMMAND ACCEPTED: ether getgw GW address: 0.0.0.0</pre>
3	<p>Enter the following command to check the ethernet netmask value:</p> <pre>sc300&gt;<b>ether getnm</b></pre> <p>Observe the following typical response (if the IP address was not set):</p> <pre>COMMAND ACCEPTED: ether getnm NETMASK: 0.0.0.0</pre>
4	<p>If the IP address is set, then you are finished with this procedure. If you must set the IP address, then proceed with steps 5 through 7.</p> <p><b>NOTE</b> The default LMF IP address is 128.0.0.2.</p>
5	<p>Enter the following command to set the IP address:</p> <pre>sc300&gt;<b>ether setip 128.0.0.2</b></pre> <p>The system will display the following output:</p> <pre>COMMAND ACCEPTED: ether setip 128.0.0.2  THESE ARE THE BYTES READ IN: 128.0.0.2 SETTING IP: 128.0.0.2   Completed flashing of IP address CONFIRM NEW IP: 128.0.0.2 SETTING Ethernet Address: 8:0:80:0:0:2   Completed flashing of Ether address CONFIRM NEW Ethernet Address: 8:0:80:0:0:2  New parameters will take affect after next reset.</pre>

... continued on next page

**Table 7-8: Procedure to Set IP Address**

Step	Action
6	<p>Enter the following command at the <code>sc300&gt;</code> prompt:  <code>sc300&gt;ether setgw 128.0.0.2</code></p> <p>The system will display the following output:</p> <pre>COMMAND ACCEPTED: ether setgw 128.0.0.2 "128" "0" "0" "2" THESE ARE THE BYTES READ IN: 128.0.0.2 SETTING GW: 128.0.0.2   Completed flashing of Gateway address CONFIRM NEW GW: 128.0.0.2 New parameters will take affect after next reset.</pre>
7	<p>Enter the following command at the <code>sc300&gt;</code> prompt:  <code>sc300&gt;ether setnm 255.255.255.255</code></p> <p>The system will display the following output:</p> <pre>COMMAND ACCEPTED: ether setnm 255.255.255.255 "255" "255" "255" "255" THESE ARE THE BYTES READ IN: 255.255.255.255 SETTING NETMASK: 255.255.255.255   Completed flashing of SubnetMask address CONFIRM NEW NETMASK: 255.255.255.255 New parameters will take affect after next reset.</pre>
8	<p>Repeat steps 1 through 3 to verify your entries.</p>
9	<p>If your entries are correct, then press the red RESET button on the diagnostic access area to reset the unit.</p>

**7**

**Procedure to Simulate an LMF Session**

You must start a simulated LMF session when you enter MMI commands. Enter the following command at the MMI prompt to simulate an LMF link:

**sndtype 0xa178**

You should enter this command at the beginning of every simulated MMI Communication Session.

**Updating Default Channel Setting to Customer Operating Channel**

A non-volatile database containing the default channel and default power level of the site must be programmed. The default channel is the customer operating channel for this site. The default power level must be set to -50 dBm which will be overwritten by the MM/OMCR when the site comes on-line.

It is imperative that the customer frequency be programmed into this database. Failure to do so may result in the RF interference to other RF-emitting devices in the local area whenever the site is powered up.

**Table 7-9:** Procedure to Update Default Channel Setting to Customer Operating Channel

Step	Action
1	Connect the LMF computer terminal to the MMI/LMF connector. Refer to Figure 7-6.
2	If you have not already done so, logout of the BTS and exit the LMF. Wait 10 seconds before proceeding.
3	Establish an MMI connection session with the BTS. Refer to Table 7-7.
4	Simulate an LMF connection by issuing the <b>sndtype 0xa178</b> command.
5	Verify that the BTS is in OOS_RAM status by issuing the <b>status</b> command.
6	<p>Enter the <b>op_param -w -50 chan#</b> command. The command parameters are as follows:</p> <ul style="list-style-type: none"> <li>-w           instructs the BTS to write the values into non-volatile memory.</li> <li>-50           defaults the power to -50dBm</li> <li>chan#       the customer operating channel (refer to Table 7-43 for 1.9 GHz systems and Table 7-44 for 800 MHz systems).</li> </ul> <p>If the command is successful, the following response will display:</p> <pre>PASSED: TRX EEPROM updated for power level = -50 (dBm) and channel = chan#</pre>
7	<p>If no additional MMI sessions are required at this time, exit the MMI session and HyperTerminal connection by selecting <b>File&gt;Exit</b>.</p> <p>If you are continuing the MMI session, proceed to Table 7-10.</p>



### Synchronization Background

#### GPS

GPS is typically used as the primary timing reference for CDMA BTSs. In applications where RGPS is used, the BTS is said to be synchronous with CDMA system time. The RGPS provides a 1 Pulse Per Second timing reference and Time Of Day information to allow the BTS to synchronize to CDMA system time.

#### HSO

A High Stability Oscillator (HSO) within the BTS provides a backup timing reference in the event of a GPS outage. Using only the HSO, the BTS can maintain CDMA system time for up to 24 hours. The BTS can also use the HSO as the primary timing reference (non-synchronous operation). However, synchronization to CDMA system time is not possible. The HSO provides a 1 Pulse Per Second timing reference to allow the BTS to remain synchronized to CDMA system time in the event of a GPS outage (synchronous operation) or to provide a stable frequency reference (non-synchronous operation).

#### NOTE

The HSO must be installed with GPS tracking for at least 24 hours before the HSO can provide 24 hours of backup for CDMA system time synchronization.

#### BTS

The BTS uses a Digital Phase Locked Loop (DPLL) to track the RGPS and/or HSO and generate a 19.6608 MHz CDMA timing reference. This timing reference, in conjunction with Time Of Day information provided by the RGPS, allows the BTS to synchronize to CDMA system time. A 2 Second reference is also generated by the BTS to allow alignment of Pilot offsets for the BTS and external test equipment. Both the 19.6608 MHz (19 MHz) and 2 Second (2 Sec) references are available via SMA connectors located in the Diagnostic Access Area.

In order for the DPLL to begin the RGPS tracking process, the RGPS must be tracking GPS satellites. In order for the DPLL to begin the HSO tracking process, the BTS must be powered up (warmed) for at least 15 minutes.

The DPLL status is defined as being in one of five states: Init, Warm, A1, A2 and TK.

- The Init state is the starting state of the DPLL.
- The Warm state is the condition during the 15 minute BTS warm up time.
- The A1 and A2 states are acquisition states when the DPLL is adjusting the 19.6608 MHz frequency based on the available reference

sources (RGPS or HSO). Under normal operating conditions, the acquisition states last about 5 minutes.

- The TK state is the DPLL tracking state and is entered at the end of the acquisition states. The TK state is required for performing ATP.

**Procedure to Verify and Change BTS Synchronization Mode**

The Sync button in the Diagnostic Access Area is used to toggle the RGPS or HSO as the primary timing reference for the BTS. If the External indicator in the Diagnostic Access Area is illuminated, the BTS expects an RGPS to be present for use as the primary timing reference. If the External indicator is not illuminated, the BTS will use the internal HSO as the primary timing reference.

Use the procedure in Table 7-10 to verify and, if necessary change the BTS Sync mode.

**Table 7-10:** Procedure to Verify and Change BTS Sync Mode

Step	Action
1	If an MMI session was established, proceed to step 7. If no MMI session is running, proceed to step 2.
2	Connect the MMI/LMF.
3	Open an MMI Communication session.
4	Simulate an LMF connection by issuing the <b>sndtype 0xa178</b> command.
5	Verify that the BTS is in OOS_RAM status by issuing the <b>status</b> command.
6	Enter the <b>sndtype 0x4003</b> command to change the state to OOS_RAM.
7	Observe the condition of the External indicator.
8	No further action is required if the BTS is in the desired Sync mode. Continue with Step 9 if the Sync mode needs to be altered.
9	Push the Sync button to change the BTS Sync mode.
10	Reset the BTS using the Reset button in the Diagnostic Access Area.
11	If no additional MMI sessions are required at this time, exit the MMI session and HyperTerminal connection by selecting <b>File&gt;Exit</b> . If you are continuing the MMI session, proceed to Table 7-11.

## Procedure to Verify DPLL Tracking (RGPS/HSO)

The DPLL within the BTS must be tracking either RGPS or HSO in order to perform ATP. Use the procedure in Table 7-11 to verify DPLL tracking.

**Table 7-11:** Procedure to Verify DPLL Tracking

Step	Action
1	If an MMI session was established, proceed to step 6. If no MMI session is running, proceed to step 2.
2	Connect the MMI/LMF.
3	Open an MMI Communication session.
4	Simulate an LMF connection by issuing the <b>sndtype 0xa178</b> command.
5	Verify that the BTS is in OOS_RAM status by issuing the <b>status</b> command.
6	If an RGPS is not present, go to Step 9.
7	<p>Enter the <b>gps_status</b> command to display the current state of the RGPS. Observe the following typical response:</p> <pre> gps_status GPS Receiver Identification: Current GPS Time                :8 03 1999   23:01:12 Current GPS Receiver Status     :8 Number of Satellites Currently visible :11 Number of Satellites Currently received :5 Number of Satellites Currently tracked :5 GPS Receiver Type               :UT Current GPS Task State          :GPS_TRACK Current Dilution of Precision (HDOP (2D)/antenna ok [0x01]): 0 Chan: 0,      SVID: 9,      Mode: 8,      RSSI: 44,      Status: 0xaa Chan: 1,      SVID: 4,      Mode: 8,      RSSI: 46,      Status: 0xaa Chan: 2,      SVID: 10,     Mode: 8,      RSSI: 44,      Status: 0xaa Chan: 3,      SVID: 6,      Mode: 8,      RSSI: 41,      Status: 0xaa Chan: 4,      SVID: 7,      Mode: 8,      RSSI: 43,      Status: 0xaa Chan: 5,      SVID: 24,     Mode: 8,      RSSI: 47,      Status: 0xaa Chan: 6,      SVID: 30,     Mode: 8,      RSSI: 45,      Status: 0xaa Chan: 7,      SVID: 5,      Mode: 8,      RSSI: 48,      Status: 0xaa Current Longitude: -350250952 Current Latitude: 118244730 Current Height: 24019                     </pre>
8	<p>The RGPS must have a Current GPS Task State of GPS_TRACK to proceed.</p> <p><b>NOTE</b> GPS tracking times vary depending on location and installation.</p>

... continued on next page





**Table 7-11:** Procedure to Verify DPLL Tracking

Step	Action
9	<p>Issue the <b>dppl_status</b> command to display the current state of the DPLL. Observe the following typical response:</p> <pre> Current source set to: GPS reference DPLL control task state: DPLL track.  DPLL status (not valid if using even sec src): c:0000  off: -8639450,6736579,7204904  TK (Note: This must say TK. A1 and A2 states will have preceded it)  Mode cntr: 120                 ip: 9,                iq: 4                 aipl: 9,               aiql: 4                 aip2: 6,               aiq2: -2                 tip: 3,                tiq: -9                 integrator:            4096                     </pre>
10	<p>Verify that the DPLL is “tracking” either the RGPS or HSO. The DPLL must have a Current source set to of GPS reference or HSO reference. The DPLL must also have a DPLL control task state of DPLL track.</p>
11	<p>If no additional MMI sessions are required at this time, exit the MMI session and HyperTerminal connection by selecting <b>File&gt;Exit</b>.</p> <p>If you are continuing the MMI session, proceed to Table 7-12.</p>

**Procedure to Verify and Modify Default Location Coordinates**

The BTS supplies the RGPS with default startup coordinates (latitude and longitude) in order to assist the RGPS in tracking satellites. The default startup coordinates can be modified and saved into non-volatile memory to speed the tracking of satellites.

Use the procedure in Table 7-12 to verify and, if necessary, modify the default startup coordinates. The procedure in Table 7-12 is only applicable to sites equipped with an RGPS.

**Table 7-12:** Procedure to Verify Default Startup Coordinates

Step	Action
1	<p>If an MMI session was established, proceed to step 6. If no MMI session is running, proceed to step 2.</p>
2	<p>Connect the LMF/MMI.</p>
3	<p>Open an MMI Communication session.</p>
4	<p>Simulate an LMF connection by issuing the <b>sndtype 0xa178</b> command.</p>
5	<p>Verify that the BTS is in OOS_RAM status by issuing the <b>status</b> command.</p>
<p>... continued on next page</p>	



**Table 7-12: Procedure to Verify Default Startup Coordinates**

Step	Action
6	Issue the <b>dppl_status</b> command to display the current state of the DPLL. Verify that the DPLL has a "Current source set to" of GPS reference and a "DPLL control task state" of DPLL track. The DPLL must be tracking GPS in order to complete this procedure.
7	<p><b>* IMPORTANT</b></p> <p>The values for longitude and latitude in response to the <b>gps_status</b> command are given in units of milli-arcseconds. Be careful to record the values accurately including any leading negative (-) signs. The value of Current Height is given in units of centimeters.</p> <p>Enter the <b>gps_status</b> command.</p>
8	Record the values displayed for Current Longitude, Current Latitude and Current Height.
9	<p><b>* IMPORTANT</b></p> <p>The <b>gps_config</b> command displays the default startup coordinates for the BTS. Note that latitude is displayed first, followed by longitude. This is in reverse order compared to the response of the <b>gps_status</b> command. The values for latitude and longitude are given in units of milli-arcseconds. The value of Current Height is given in units of centimeters.</p> <p>Enter the <b>gps_config</b> command to display the default startup coordinates for the BTS. Observe the following typical response:</p> <pre data-bbox="302 1003 1159 1213">GPS Configuration data:     latitude:           151679715 msec     longitude:          -316791269 msec     height:             19740 centi-meters     height_type:        0     cable_delay:        0 nsec     accuracy:           0</pre> <p>If the default startup coordinates need to be modified, the <b>gps_config</b> command can be issued with additional parameters. Using the Current Longitude, Current Latitude and Current Height values recorded in step 8, issue the following command:</p> <pre data-bbox="302 1339 1130 1371"><b>gps_config</b> &lt;latitude&gt; &lt;longitude&gt; &lt;height&gt; 0 0 0</pre> <p>Be careful to input the latitude and longitude in the proper order along with any leading negative (-) signs.</p> <p>The GPS Height Type Configuration should be set to "0."</p>
10	Issue the <b>gps_config</b> to verify that the coordinates are set.
11	Reset the BTS to save the new coordinates.
12	Repeat the steps in Table 7-11 to verify the DPLL status prior to performing ATP.
13	If no additional MMI sessions are required at this time, exit the MMI session and HyperTerminal connection by selecting <b>File&gt;Exit</b> .

7

## BTS Configuration – continued

### Procedure to Set Frame ID for Multi-Unit Logical BTS Configuration

Do the following procedure in Table 7-13 to setup the hardware for a multi-unit logical BTS configuration.

<b>Table 7-13: Procedure to Set Frame ID for Multi-Unit Logical BTS Configuration</b>	
<b>Step</b>	<b>Action</b>
1	Establish an MMI session with the BTS. Refer to Table 7-7.
2	Enter the following command at the SC300> prompt to set the frame ID to “1” on the first frame: <b>frame_id 1</b> You can also set the frame_id to 1 by pressing the CU-ID button on the diagnostic access area to the “CARRIER #1” state.
3	Enter the following command at the SC300> prompt to set the frame ID to “2” on the second frame: <b>frame_id 2</b> You can also set the frame_id to 2 by pressing the CU-ID button on the diagnostic access area to the “CARRIER #2” state.
4	If you have three or more units, enter the following command at the SC300> prompt to set the frame ID to “3” on the third frame: <b>frame_id 3</b> You can also set the frame_id to 3 by pressing the CU-ID button on the diagnostic access area to the “CARRIER #3” state.
5	If you have four units, enter the following command at the SC300> prompt to set the frame ID to “4” on the second frame: <b>frame_id 4</b> You can also set the frame_id to 4 by pressing the CU-ID button on the diagnostic access area to the “CARRIER #4” state.
6	Press the SYNC button on the diagnostic access area on all of the units to switch them to the “EXTERNAL” mode.
7	If the frame_id of unit #1 is already set to “1” prior to the setup of the BTS, then you do not need to reset it. If the frame_id is not “1,” then you must press the RESET button on the diagnostic access area to reset unit #1.
8	Press the RESET buttons on the diagnostic access areas of units #2, #3 (if equipped), and #4 (if equipped).

## Objective

This objective of this procedure is to:

1. Install the LMF program.
2. Create a site specific BTS directory.
3. Start the LMF.
4. Login to the BTS
5. Update the BTS-specific CDF file.
6. Download and enable the MAWI

## Install the LMF Program and BTS Binaries

Install the LMF and BTS binaries on the PC to be used if they are not already installed. Refer to the *CDMA LMF Operator's Guide, 68P64114A78* for the installation procedure.

## Create a Site-Specific BTS Directory

Follow the steps in Table 7-14 to create a `bts-bts#` directory, to which the `bts-bts#.cdf`, `cbsc-1.cdf`, and ATP report files will reside.

**Table 7-14:** Procedure to Create Site-Specific BTS Directory

Step	Action
1	Use MS Windows Explorer to create a <code>bts-#</code> folder under the <code>wlmf\cdma</code> folder (where # is the BTS number).
2	Get the <code>bts-#.cdf</code> file and <code>cbsc-#.cdf</code> file from the CBSC and put a copy of the files in the <code>wlmf\cdma\bts-#</code> folder. Refer to the LMF help screens or the <i>CDMA LMF Operator's Guide, 68P64114A21</i> for the copy file procedure.

## Start the LMF and Login to the BTS

Use the following procedure in Table 7-15 to start the LMF and login to the BTS.

### Prerequisites

1. A `bts-#` folder with a correct CDF and CBSC file exists.
2. The LMF notebook is correctly set up and connected to the BTS. Refer to Figure 7-6.

### NOTE

The **Refresh** button can be used to update the **Available Base Stations** pick list to include any new `bts-#` folders added/created after the LMF was started. To logout of the BTS, click on **Select>Logout**. A confirm logout pop-up message will appear.

**Table 7-15:** Procedure to Start the LMF and Login to the BTS

Step	Action
1	Click on the <b>LMF</b> desktop icon. The LMF window should appear.
2	Click on the <b>Login</b> tab if it is not already displayed.
3	Double-click on <b>CDMA</b> in the <b>Available Base Stations</b> pick list if the list of available BTSs is not displayed.
4	Click on the desired BTS.
5	Is all of the information in the <b>Serial Login</b> tab and <b>Equipage Information</b> box list correct? – If YES, go to step 7. – If NO, go to step 6.
6	Click on the <b>Serial Login</b> tab if it is not in the forefront. Select the correct <b>Comm Port</b> (normally <b>COM2</b> ) and select the desired <b>Baud Rate</b> (normally 9600 for tests and 38400 for downloads).  <b>NOTE</b> This step is not necessary if you are using the Ethernet LAN connection from the LMF to the BTS.
7	Click on the <b>Login</b> button. The system will display a graphic of the SC300 BTS.

**Update BTS Specific CDF File  
Device Load Version**

Follow the steps in Table 7-16 to update the existing BTS specific CDF file *NextLoad* parameter to reflect the current device load version to be downloaded.

The **NextLoad** version parameter in the CDF file for a BTS can be updated to one of the existing version numbers in the `wlmf>cdma>loads` folder. When code is downloaded the code file used is determined by the **NextLoad** parameter in the CDF file. If a version number folder that has the same number as the **NextLoad** parameter is not found when the download code function is used the LMF will not automatically select the code and data files to be downloaded.

**NOTE**

Device load version in the CDF file does not have to match the current version loaded at the OMCR/CBSC.

**Table 7-16:** Procedure to Update BTS-Specific CDF File Device Load Version

Step	Action
1	Click on the <b>Tools</b> menu item.
2	Select the <b>Update NextLoad</b> item.
. . . continued on next page	

**Table 7-16:** Procedure to Update BTS-Specific CDF File Device Load Version

Step	Action
3	Select <b>CDMA</b> .
4	Select the BTS number from the list of available base stations.
5	Select the radio button next to the desired version number.
6	Click on the <b>Save</b> button. A pop-up message will appear indicating that “This action may take a few seconds.” Click on the <b>OK</b> button.
7	A pop-up message will appear indicating that the NextLoad file has been updated. <b>NOTE</b> At this point, a backup copy of the original CDF is created with a _bak extension, (e.g., bts-812.cdf_bak).
8	Click on the <b>OK</b> button to dismiss the pop-up message.

**Download/Enable MAWI**

The objective of this procedure is to download and enable the BTS.

The BTS software platform is based on the Motorola Advanced Wideband Interface (MAWI). The term MAWI is used to refer to the MicroCell from the LMF’s point of view.

**NOTE**

The BTS is shipped from the factory with all the software downloaded. Use the load procedure only when new software is loaded.

Follow the steps outlined in Table 7-17 to download the code and data to enable the MAWI.

Before the download/enable process, use the **status** function and verify the MAWI responds with status information. Use this information to get the current code loaded in MAWI.

**Table 7-17:** Procedure to Download/Enable MAWI

Step	Action
1	If the ATP is going to be run, the MAWI has to have the same code load as the LMF CDF or the site specific information cannot be loaded to MAWI (PN offset, etc.) for ATP to complete.
2	If downloading code, insure the LMF is logged into the BTS at 38400 Baud Rate for timely download (20 minutes vs 2+ hours).
3	Click on the MAWI and select <b>Device&gt;Download&gt;Code Manual</b> . A status report is displayed that confirms the change in device status. Click <b>OK</b> to close status window.

. . . continued on next page



**Table 7-17:** Procedure to Download/Enable MAWI

Step	Action
4	Click on the MAWI and select <b>Device&gt;Download&gt;Code Data</b> . A status report is displayed that confirms the change in device status. Click OK to close status window.
5	Click on the MAWI and select <b>Device&gt;Enable</b> to enable the MAWI. The MAWI changes to green (INS- <del>ACT</del> test mode).  <b>NOTE</b> The LMF may fail this step. After you enable the MAWI, verify that the LED on the SC300 changes to a solid green, then click on the STOP radio button to halt the <b>ENABLE</b> command. Run the <b>STATUS MAWI</b> command and the display will change to the INS_ACT (green) state.

**Configuration Data File (CDF)**

The Configuration Data File (CDF) includes the CDMA channel element allocation plan. This plan indicates how each CDMA carrier is configured, and how the paging, sync, traffic, and access channel elements (and associated gain values) are assigned.

The CDF file also contains a table for the Effective Rated Power (ERP) for each transmit antenna. Motorola System Engineering specifies the ERP of a transmit antenna based on site geography, antenna placement, and government regulations. Working from this ERP requirement, the antenna gain, (dependent on the units of measurement specified) and antenna feed line loss can be combined to determine the required power at the BTS TX output.

**NOTE**

Refer to the *CDMA LMF Operators Guide; 68P64114A78* for additional information on the layout of the LMF directory structure (including cdf file locations and formats).

**Site equipage verification**

If you have not already done so, use an editor to view the CDF, and review the site documentation. Verify the site engineering equipage data in the CDF to the actual site hardware.

**NOTE**

If the current LMF or BTS binaries need to be installed on the LMF PC, or for more information on viewing CDF files, refer to the *CDMA LMF Operators Guide; 68P64114A78*.

**System Status LED States**

Table 7-18 lists all of the possible system status LED states.

<b>Table 7-18: System Status LED States</b>	
<b>System Status LED</b>	<b>Status Indication</b>
Steady Green	INS_ACT <sup>3</sup> or INS_SBY <sup>4</sup> , no alarms
Slow Flashing Red/Green (0.2s Red, 1.4s Green)	INS_ACT or INS_SBY w/alarms(s)
Fast Flashing Green/Off (0.2s Green, 0.2s Off)	OOS_RAM <sup>1</sup> with no alarms
Fast Flashing Red/Green (0.2s Red, 0.2s Green)	OOS_RAM with alarms(s)
Slow Flashing Green/Off (0.2s Green, 1.4s Off)	OOS_ROM <sup>2</sup> with no alarms
Slow Flashing Green/Red (0.2s Green, 1.4s Red)	OOS_ROM with alarm(s)
Steady Red	Critical hardware failure
Fast Flashing Red/Off (0.25s Red/0.25s Off) <sup>5</sup>  <b>NOTE</b> The MAWI has powered up in boot code because the ROM code is either corrupt or not present. This condition may indicate a MAWI hardware failure.	#1: RAM test failure #2: FLASH 1 (512K) manufacture/device ID mismatch #3: FLASH 2 (512K) manufacture/device ID mismatch #4: FLASH 3 (512K) manufacture/device ID mismatch #5: Modem present but untrained #6: Unknown interrupt event #7: Reset by hardware watchdog timeout #8: Reset by software watchdog timeout #9: Reset by double bus fault #10: Reset by loss of clock #11: Reset by RESET instruction #12: Reset by soft reset pin
Off	No DC Power applied to module
<sup>1</sup> OOS_RAM refers to a MAWI that is loaded but not enabled <sup>2</sup> OOS_ROM refers to a MAWI that is not loaded. <sup>3</sup> INS_ACT refers to a MAWI that is in service and active. <sup>4</sup> INS_SBY refers to a MAWI that is in service but on standby. <sup>5</sup> The number of flashes equals the alarm #, with a three-second pause between flashes.	

7



# Verify and Set Span Line Settings

## Objective

The following procedure is to verify and configure the BTS Span line interface for T-1 or E-1 configurations.

## Span Line Settings

The following are the span line settings for the BTS span line interface.

- Span A: Primary span
- Span B: Downstream span used for daisy-chaining.

## Procedure to Verify and Set Span Line Settings

Use the procedure in Table 7-19 to verify and set (if necessary) the span line settings.



### IMPORTANT

Both spans A and B must be set to either T-1 or E-1. The spans must match the parameters of the CBSC.

**Table 7-19:** Procedure to Verify and Set Span Line Settings

Step	Action
1	If you have not already done so, connect the LMF computer terminal to the MMI/LMF connector. Refer to Table 7-7.
2	Open an MMI communications session. Refer to Table 7-6.
3	Enter the following command at the SC300> prompt to verify the current span settings: <b>span_config a</b> The system will display the following output:  Span A data: Span type: 5 - T1_2 (B8ZS, DS1 AT&T ESF 4 to 1 packing, 64K link) Link Speed: 64K Span EQ: 0 - T1_6 (T1, J1:longhaul, same as choice 10) LAPD slot: 0
4	Enter the following command at the SC300> prompt to verify the current span settings: <b>span_config b</b> The system will display the following output:  Span B data: Span type: 1 - E1_2 (HDB3) Link Speed: 64K Span EQ: 16 - E1 (Long haul: 120 Ohm) LAPD slot: 1

... continued on next page

## Verify and Set Span Line Settings – continued

**Table 7-19:** Procedure to Verify and Set Span Line Settings

Step	Action
5	<p>If the span line settings are not the same for spans A and B, then enter the <b>SPAN_CONFIG</b> command for span A. Refer to the <b>SPAN_CONFIG</b> parameters in Table 7-20.</p> <pre>SC300&gt;span_config &lt;span&gt; &lt;span type&gt; &lt;link speed&gt; &lt;span equalization&gt; &lt;LAPD channel&gt;</pre> <p>The <b>SPAN_CONFIG</b> parameters shown below are an example and may not be applicable to your configuration.</p> <pre>SC300&gt;span_config a 5 64 0 0</pre> <p>The system will return to the SC300&gt; prompt:</p>
6	<p>Enter the <b>SPAN_CONFIG</b> command for span B. Use the same parameters that you used in step 5. Refer to the <b>SPAN_CONFIG</b> parameters in Table 7-20.</p> <pre>SC300&gt;span_config &lt;span&gt; &lt;span type&gt; &lt;link speed&gt; &lt;span equalization&gt; &lt;LAPD channel&gt;</pre> <p>The <b>SPAN_CONFIG</b> parameters shown below are an example and may not be applicable to your configuration.</p> <pre>SC300&gt;span_config b 5 64 0 0</pre> <p>The system will return to the SC300&gt; prompt:</p>
7	<p>Enter the following command at the SC300&gt; prompt to verify the changes to the span A settings:</p> <pre>SC300&gt;span_config a</pre> <p>The system will display the following <i>typical</i> output.</p> <pre>Span A data:   Span type:  5 - T1_2 (B8ZS, DS1 AT&amp;T ESF 4 to 1 packing, 64K link)   Link Speed: 64K   Span EQ:   0 - T1_6 (T1, J1:longhaul, same as choice 10)   LAPD slot: 0</pre>
8	<p>Enter the following command at the SC300&gt; prompt to verify the changes to the span B settings:</p> <pre>SC300&gt;span_config b</pre> <p>The system will display the following <i>typical</i> output.</p> <pre>Span B data:   Span type:  5 - T1_2 (B8ZS, DS1 AT&amp;T ESF 4 to 1 packing, 64K link)   Link Speed: 64K   Span EQ:   0 - T1_6 (T1, J1:longhaul, same as choice 10)   LAPD slot: 0</pre>

## Verify and Set Span Line Settings – continued

### SPAN\_CONFIG Parameters

The following parameters in Table 7-20 are for the **SPAN\_CONFIG** command.

Table 7-20: SPAN_CONFIG Command Parameters	
Parameter	Values
<span>	A or B
<span type>	0 = E1_1 (HDB3, CRC-4) 1 = E1_2 (HDB3) 2 = E1_3 (HDB3, CRC-4, TS16) 3 = E1_4 (HDB3, TS16) 4 = T1_1 (AMI, DS1 AT&T D4, Ext ZCS, 3 to 1 packing, Group 0 unusable) 5 = T1_2 (B8ZS, DS1 AT&T ESF 4 to 1 packing, 64K link) 6 = J1_1 (B8ZS, J1 AT&T ESF, Japan CRC6, 4 to 1 packing) 7 = J1_2 (B8ZS, J1 AT&T ESF, US CRC6, 4 to 1 packing) 8 = T1_3 (AMI, DS1vAT&T D4, Int ZCS, 3 to 1 packing, Group 0 unusable)
<link speed>	56 or 64
<span equalization>	0 = T1_6 (T1,J1: long haul, same as choice 10) 1 = T1_4 (T1,J1:393-524 feet) 2 = T1_2 (T1,J1:131-262 feet) 3 = E1_75 (E1:120 Ohm / 75 Ohm coax) 4 = T1_1 (T1,J1:0-131 feet) 5 = T1_5 (T1,J1:524-655 feet) 6 = T1_3 (T1,J1:262-393 feet) 7 = E1_120 (E1:120 Ohm) 8 = T1 (T1,J1: long haul pulse 0 dB, gain 36 dB) 9 = T1 (T1,J1: long haul pulse -7.5 dB, gain 36 dB) 10 = T1 (T1,J1: long haul pulse -15 dB, gain 36 dB) 11 = T1 (T1,J1: long haul pulse -22 dB, gain 36 dB) 12 = T1 (T1,J1: long haul pulse 0 dB, gain 26 dB) 13 = T1 (T1,J1: long haul pulse -7.5 dB, gain 26 dB) 14 = T1 (T1,J1: long haul pulse -15 dB, gain 26 dB) 15 = T1 (T1,J1: long haul pulse -22 dB, gain 26 dB) 16 = E1 (Long haul: 120 Ohm) 17 = E1 (Long haul: 120 Ohm / 75 Ohm coax)
<LAPD channel>	0-31

# GPIB Addresses

## Introduction

Use the following procedures to verify and/or change the GPIB addresses of the applicable test equipment.

GPIB addresses can range from 1 through 30. The LMF will accept any address in that range, but the numbers in the GPIB address boxes must match the addresses of the test equipment. Motorola recommends that you use 1 for a CDMA signal generator, 13 for a power meter, and 18 for a CDMA analyzer.

### NOTE

The following procedures assume that the test equipment is set up and ready for testing.

## Verify the Gigatronics 8541C Power Meter GPIB Address

Follow the steps in Table 7-21 to verify and, if necessary, change the Gigatronics 8541C power meter GPIB address.

**Table 7-21:** Verify and/or Change Gigatronics 8541C Power Meter GPIB Address

Step	Action
1	<b>! CAUTION</b> Do not connect/disconnect the power meter sensor cable with AC power applied to the meter. Disconnection could result in destruction of the sensing element or miscalibration. Press <b>MENU</b> (refer to Figure 7-18).
2	Use the <b>▼</b> arrow key to select <b>CONFIG MENU</b> and press <b>ENTER</b> .
3	Use the <b>▼</b> arrow key to select <b>GPIB</b> and press <b>ENTER</b> . The system displays the current <b>Mode</b> and <b>GPIB Address</b> .
4	If the <b>Mode</b> is not set to <b>8541C</b> , perform the following to change it: – Use the <b>◀▶</b> arrow keys as required to select <b>MODE</b> . – Use the <b>▼▲</b> arrow keys as required to set <b>MODE</b> to <b>8541C</b> .
5	If the GPIB address is not set to <b>13</b> , perform the following to change it: – Use the <b>▶</b> arrow key to select <b>ADDRESS</b> . – Use the <b>▼▲</b> arrow keys as required to set the GPIB address to <b>13</b> .
6	Press <b>ENTER</b> to return to normal operation.

**Figure 7-18:** Gigatronics 8541C Power Meter Detail

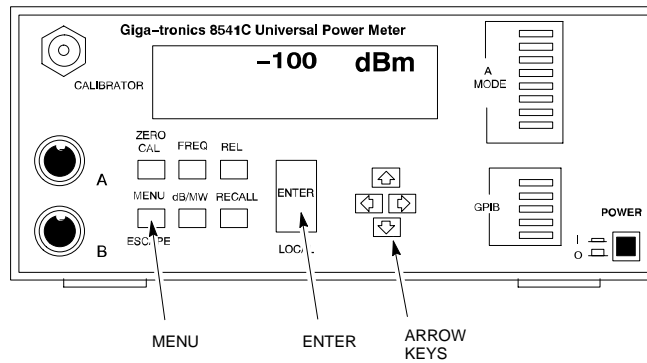

**Verify and Set Motorola CyberTest GPIB Address**

Follow the steps in Table 7-22 to verify and, if necessary, change the GPIB address on the Motorola CyberTest. Changing the GPIB address requires the following items:

- Motorola CyberTest communications analyzer.
- Computer running Windows 3.1/Windows 95.
- Motorola CyberTAME software program “TAME”.
- Parallel printer port cable (shipped with CyberTest).

**Table 7-22:** Verify and/or Change Motorola CyberTest GPIB Address

Step	Action
1	On the LMF desktop, locate the <b>CyberTAME</b> icon. Double click on the icon to run the CyberTAME application.
2	In the CyberTAME window taskbar, under <b>Special</b> , select <b>IEEE.488.2</b> .
3	<p>CyberTAME software will query the CyberTest Analyzer for its current GPIB address. It will then open the IEEE 488.2 dialog box. If the current GPIB address is not 18, perform the following steps to change it:</p> <ul style="list-style-type: none"> <li>– Use the up or down increment arrows, or double-click in the field and type the number.</li> <li>– Click on the <b>OK</b> button. The system will write and save the new address to the CyberTest via the parallel port.</li> </ul> <p><b>NOTE</b> Repeat steps 2 and 3 to verify that the address was set. The new address should now appear in the IEEE 488.2 dialog box Address field.</p>

## GPIB Addresses – continued

### Verify and Set HP8935 Test Set GPIB Address

Follow the procedure in Table 7-23 to verify and, if necessary, change the HP8935 GPIB address.

Table 7-23: Verify and/or Change HP8935 GPIB Address	
Step	Action
1	<p> * <b>IMPORTANT</b></p> <p> The HP I/O configuration <b>MUST</b> be set to <b>Talk &amp; Listen</b>, or NO device on the GPIB bus will be accessible (if necessary, consult test equipment OEM documentation for additional information).</p> <p> To verify that the GPIB addresses are set correctly, press <b>Shift</b> and <b>LOCAL</b> on the HP8935 (refer to Figure 7-19). The current HP-IB address will display at the top of the screen.</p> <p> <b>NOTE</b>  HP-IB is the same as GPIB.</p>
2	<p> If the current GPIB address is not set to <b>18</b>, perform the following steps to change it:</p> <ul style="list-style-type: none"> <li> – Press <b>Shift</b> and <b>Inst Config</b>.</li> <li> – Turn the <b>Cursor Control</b> knob to move the cursor to the <b>HP-IB Adrs</b> field.</li> <li> – Press the <b>Cursor Control</b> knob to select the field.</li> <li> – Turn the <b>Cursor Control</b> knob as required to change the address to <b>18</b>.</li> <li> – Press the <b>Cursor Control</b> knob to set the address.</li> </ul>
3	Press <b>Preset</b> to return to normal operation.

Figure 7-19: HP8935 Test Set

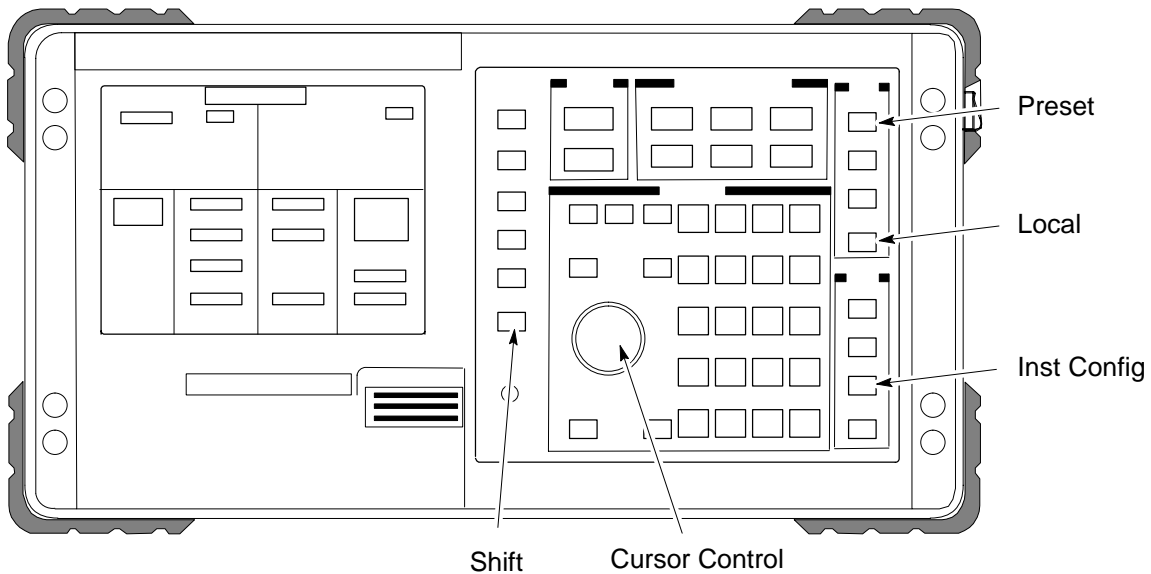

FW00885

7

## GPIO Addresses – continued

### Verify and Set the HP8921A and HP83236A/B GPIO Addresses

Follow the procedure in Table 7-24 to verify and, if necessary, change the HP8921A/HP83236A GPIO addresses.

Table 7-24: Verify and/or Change HP8921A and HP83236A GPIO Addresses	
Step	Action
1	To verify that the GPIO addresses are set correctly, press <b>Shift</b> and <b>LOCAL</b> on the HP8921A (refer to Figure 7-20). The current HP-IB address is displayed at the top of the screen.  <b>NOTE</b> HP-IB is the same as GPIO.
2	If the current HP-IB address is not set to <b>18</b> , perform the following to change it: <ul style="list-style-type: none"> <li>– Turn the <b>Cursor Control</b> knob to move the cursor to <b>More</b> and press the knob to select the field.</li> <li>– Turn the <b>Cursor Control</b> knob to move the cursor to <b>I/O Config</b> and press the knob to select the field.</li> <li>– Turn the <b>Cursor Control</b> knob to move the cursor to <b>Adrs</b> and press the knob to select the field.</li> <li>– Turn the <b>Cursor Control</b> knob to change the HP-IB address to 18 and press the knob to set the address.</li> <li>– Press <b>Shift</b> and <b>Preset</b> to return to normal operation.</li> </ul>
3	To set the HP83236A (or B) PCS Interface GPIO address=19, set the dip switches as follows: <ul style="list-style-type: none"> <li>– A1=1, A2=1, A3=0, A4=0, A5=1, HP-IB/Ser = 1</li> </ul>

Figure 7-20: HP8921A and HP83236A/B

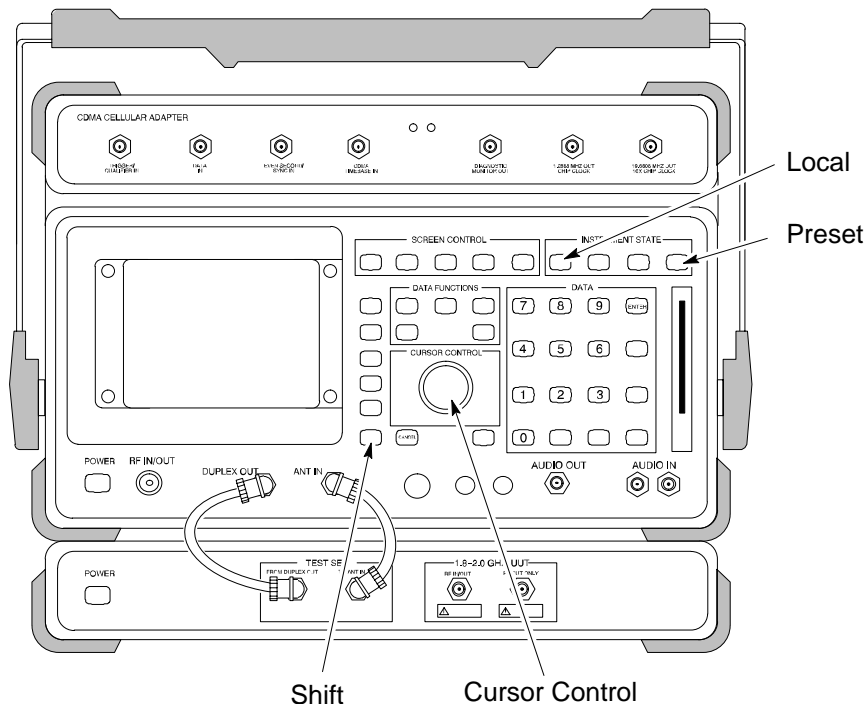

## GPiB Addresses – continued

### Verify and Set Advantest R3465 GPiB Address

Table 7-25 describes the steps to verify and, if necessary, change the GPiB address for the Advantest R3465.

Table 7-25: Verify and/or Change Advantest R3465 GPiB Address	
Step	Action
1	Perform the following procedure to verify that the GPiB address is set correctly: <ul style="list-style-type: none"> <li>– Press <b>SHIFT</b> then <b>PRESET</b> (see Figure 7-21).</li> <li>– Press <b>LCL</b>.</li> <li>– Press the <b>GPiB and Others CRT</b> menu key to view the current address.</li> </ul>
2	If the current GPiB address is not set to <b>18</b> , perform the following to change it: <ul style="list-style-type: none"> <li>– Turn the vernier knob as required to select <b>18</b>.</li> <li>– Press the vernier knob to set the address.</li> </ul>
3	To return to normal operation, press <b>Shift</b> and <b>Preset</b> .

Figure 7-21: R3465 Communications Test Set

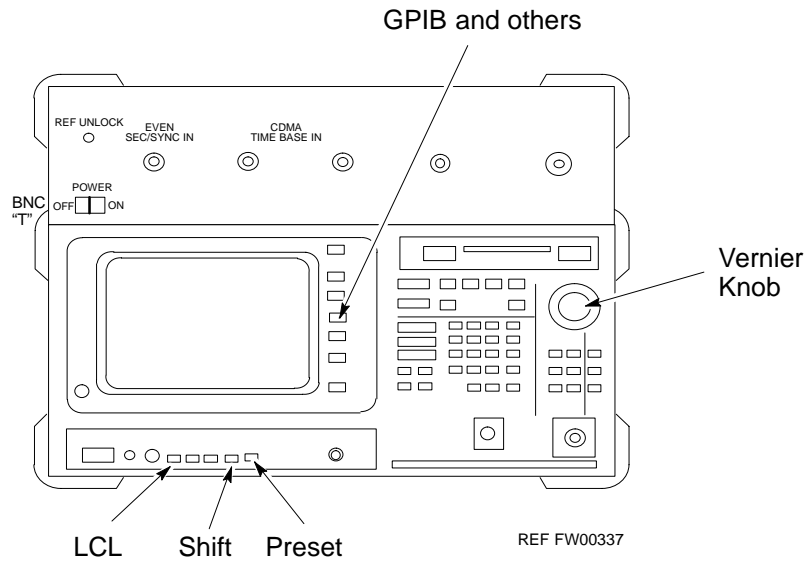

7



## GPIB Addresses – continued

### RS232 GPIB Interface Box

Ensure that the RS232 GPIB interface box dip switches are set as shown in Figure 7-22.

**Figure 7-22:** RS232 GPIB Interface Box

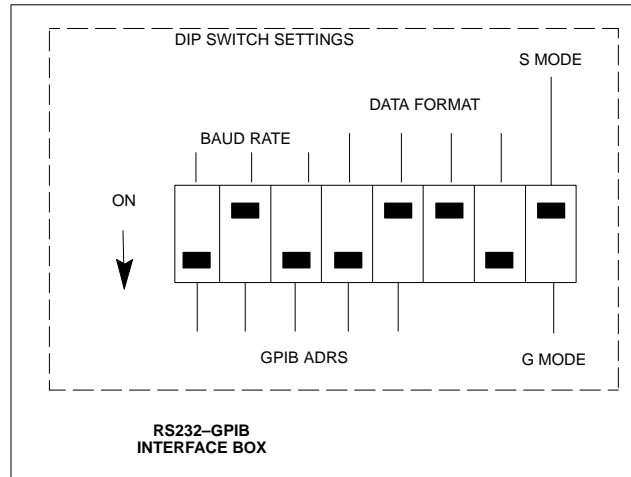

### Verify and Set Advantest R3267 GPIB Address

Perform the procedure in Table 7-26 and refer to Figure 7-23 to verify and, if necessary, change the Advantest R3267 spectrum analyzer GPIB address.

**Table 7-26:** Verify and Change Advantest R3267 GPIB Address

Step	Action
1	If the <b>REMOTE</b> LED is lighted, press the <b>LCL</b> key. – The LED extinguishes.
2	Press the <b>CONFIG</b> key. – The <b>CONFIG</b> softkey labels will appear in the softkey label display area of the instrument display. – The current GPIB address will be displayed below the <b>GPIB Address</b> softkey label.
3	If the current GPIB address is not set to <b>18</b> , perform the following to change it:
3a	Press the <b>GPIB Address</b> softkey. – A <b>GPIB Address</b> entry window will open in the instrument display showing the current GPIB address.

. . . continued on next page

## GPIB Addresses – continued

**Table 7-26:** Verify and Change Advantest R3267 GPIB Address

Step	Action
3b	<p>Enter <b>18</b> on the keypad in the <b>ENTRY</b> section of the instrument front panel.</p> <ul style="list-style-type: none"><li>– Characters typed on the keypad will replace the address displayed in the <b>GPIB Address</b> entry window.</li></ul> <p><b>NOTE</b></p> <p>To correct an entry, press the <b>BS</b> (backspace) key at the lower right of the keypad to delete one character at a time.</p>
3c	<p>Press the <b>ENTR</b> key to the lower right of the keypad to enter the address.</p> <ul style="list-style-type: none"><li>– The <b>GPIB Address</b> entry window closes.</li><li>– The new address is displayed in the bottom portion of the <b>GPIB Address</b> softkey label.</li></ul>

**Figure 7-23:** Setting Advantest R3267 GPIB Address

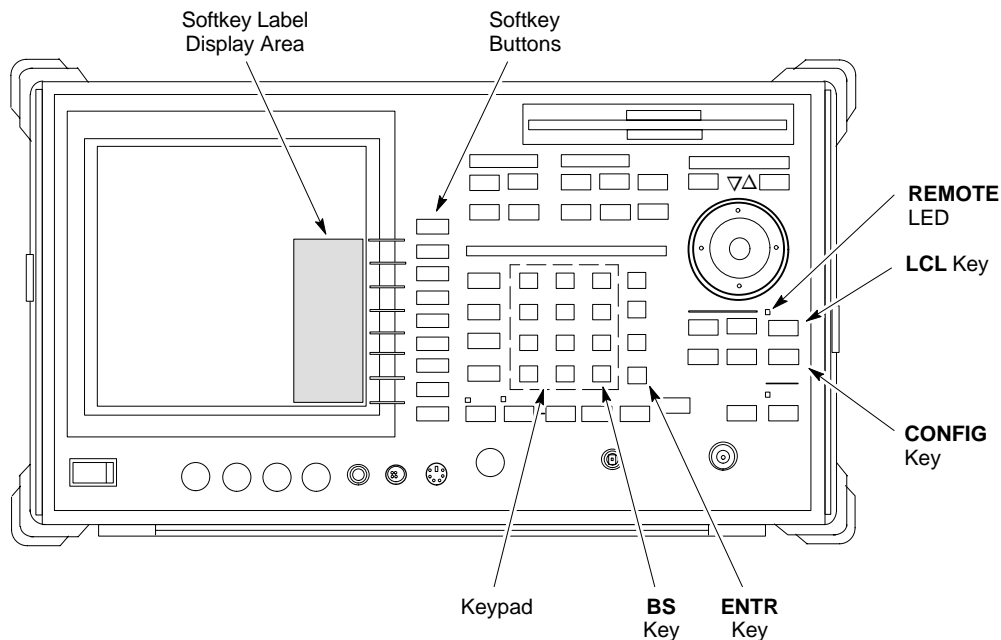

7

**Verify and Set Advantest R3562  
Signal Generator GPIB  
Address**

Set the **GP-IP ADDRESS** switch on the rear of the Advantest R3562 signal generator to address **1** as shown in Figure 7-24.

**Figure 7-24:** Advantest R3562 GPIB Address Switch Setting

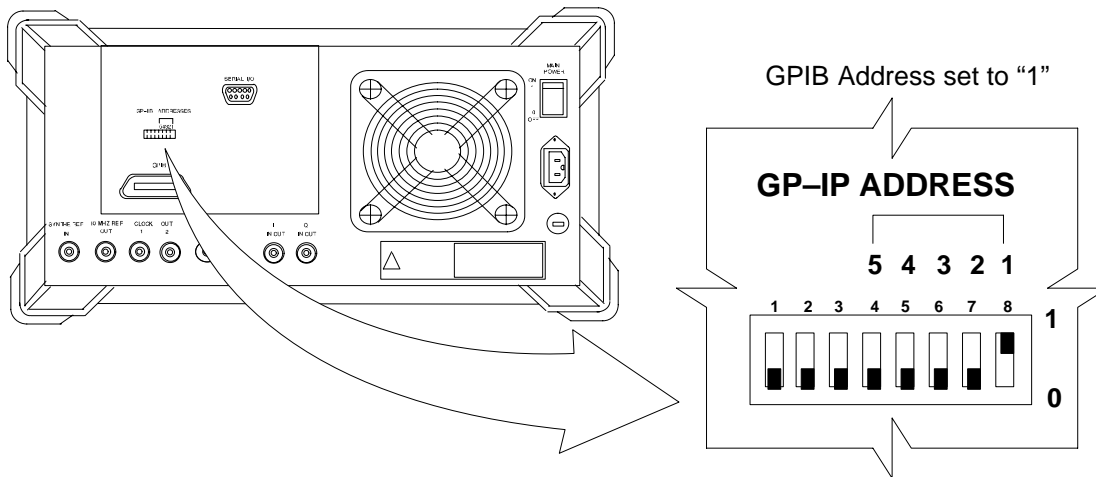

**Verify and Set Agilent E4406A  
Transmitter Tester GPIB  
Address**

Follow the procedure in Table 7-27 and refer to Figure 7-25 to verify and, if necessary, change the Agilent E4406A GPIB address.

**Table 7-27:** Verify and Change Agilent E4406A GPIB Address

Step	Action
1	In the <b>SYSTEM</b> section of the instrument front panel, press the <b>System</b> key. The softkey labels displayed on the right side of the instrument screen will change.
2	Press the <b>Config I/O</b> softkey button to the right of the instrument screen. <ul style="list-style-type: none"> <li>– The softkey labels will change.</li> <li>– The current instrument GPIB address will display below the <b>GPIB Address</b> softkey label.</li> </ul>
3	If the current GPIB address is not set to <b>18</b> , perform the following to change it:
3a	Press the GPIB Address softkey button. In the on-screen Active Function Area, <b>GPIB Address</b> will be displayed followed by the current GPIB address.

... continued on next page

**Table 7-27: Verify and Change Agilent E4406A GPIB Address**

Step	Action
3b	<p>On the front panel Data Entry keypad, enter the communications system analyzer GPIB address of <b>18</b>.</p> <ul style="list-style-type: none"> <li>– The <b>GPIB Address</b> label will change to <b>Enter</b>.</li> <li>– Digits entered with the keypad will replace the current GPIB address in the display.</li> </ul> <p><b>NOTE</b> To correct an entry, press the <b>Bk Sp</b> key at the upper right of the keypad to delete one character at a time.</p>
3c	<p>Press the <b>Enter</b> softkey button or the keypad <b>Enter</b> key to set the new GPIB address.</p> <ul style="list-style-type: none"> <li>– The <b>Config I/O</b> softkey labels will re-appear.</li> <li>– The new GPIB address will display under the <b>GPIB Address</b> softkey label.</li> </ul>

**Figure 7-25: Setting Agilent E4406A GPIB Address**

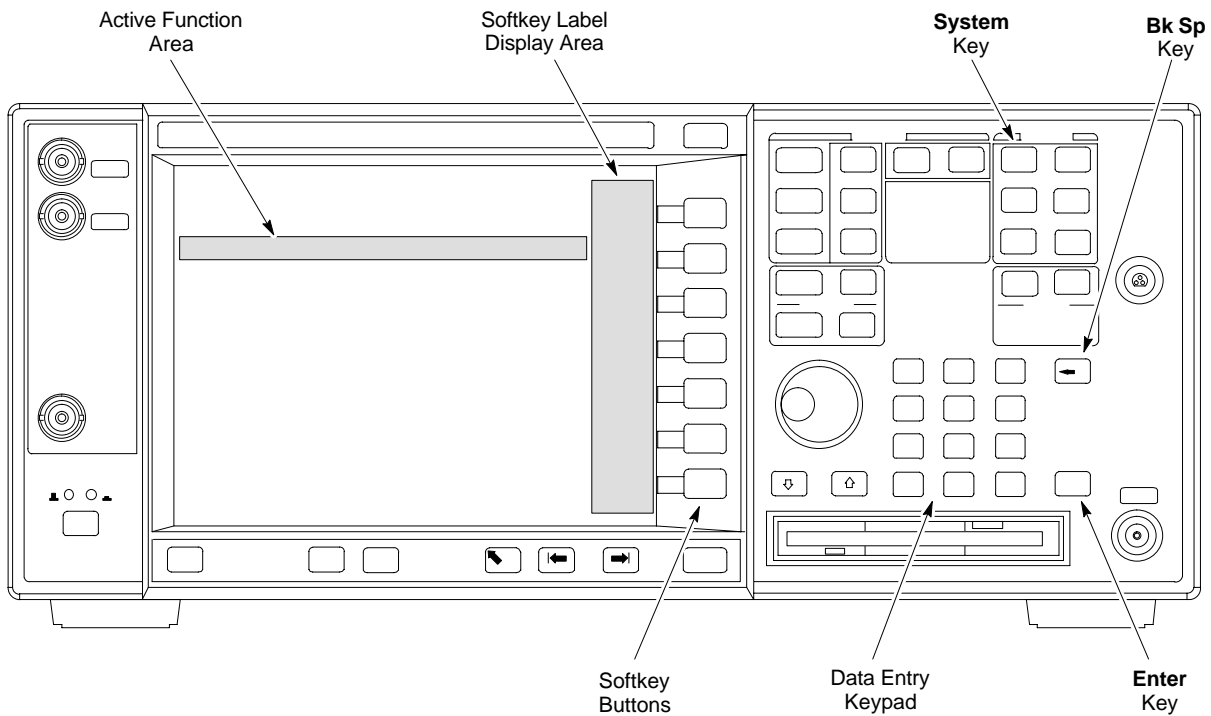

7

## GPIB Addresses – continued

### Verify and Set Agilent E4432B Signal Generator GPIB Address

Refer to Figure 7-26 and follow the procedure in Table 7-28 to verify and, if necessary, change the Agilent E4432B GPIB address.

<b>Table 7-28: Verify and Change Agilent E4432B GPIB Address</b>	
<b>Step</b>	<b>Action</b>
1	In the <b>MENUS</b> section of the instrument front panel, press the <b>Utility</b> key. <ul style="list-style-type: none"><li>– The softkey labels displayed on the right side of the instrument screen will change.</li></ul>
2	Press the <b>GPIB/RS232</b> softkey button to the right of the instrument screen. <ul style="list-style-type: none"><li>– The softkey labels will change.</li><li>– The current instrument GPIB address will be display below the <b>GPIB Address</b> softkey label.</li></ul>
3	If the current GPIB address is not set to <b>1</b> , perform the following to change it:
3a	Press the <b>GPIB Address</b> softkey button. <ul style="list-style-type: none"><li>– The <b>GPIB Address</b> label and current GPIB address will change to boldface.</li><li>– In the on–screen Active Entry Area, <b>Address:</b> and the current GPIB address will display.</li></ul>
3b	On the front panel Numeric keypad, enter the signal generator GPIB address of <b>1</b> . <ul style="list-style-type: none"><li>– The <b>GPIB Address</b> label will change to <b>Enter</b>.</li><li>– Digits entered with the keypad will replace the current GPIB address in the Active Entry display.</li></ul> <p><b>NOTE</b> To correct an entry, press the backspace key at the lower right of the keypad to delete one character at a time.</p>
3c	Press the <b>Enter</b> softkey button to set the new GPIB address. <ul style="list-style-type: none"><li>– The new GPIB address will be display under the <b>GPIB Address</b> softkey label.</li></ul>

**Figure 7-26:** Setting Agilent E4432B GPIB Address

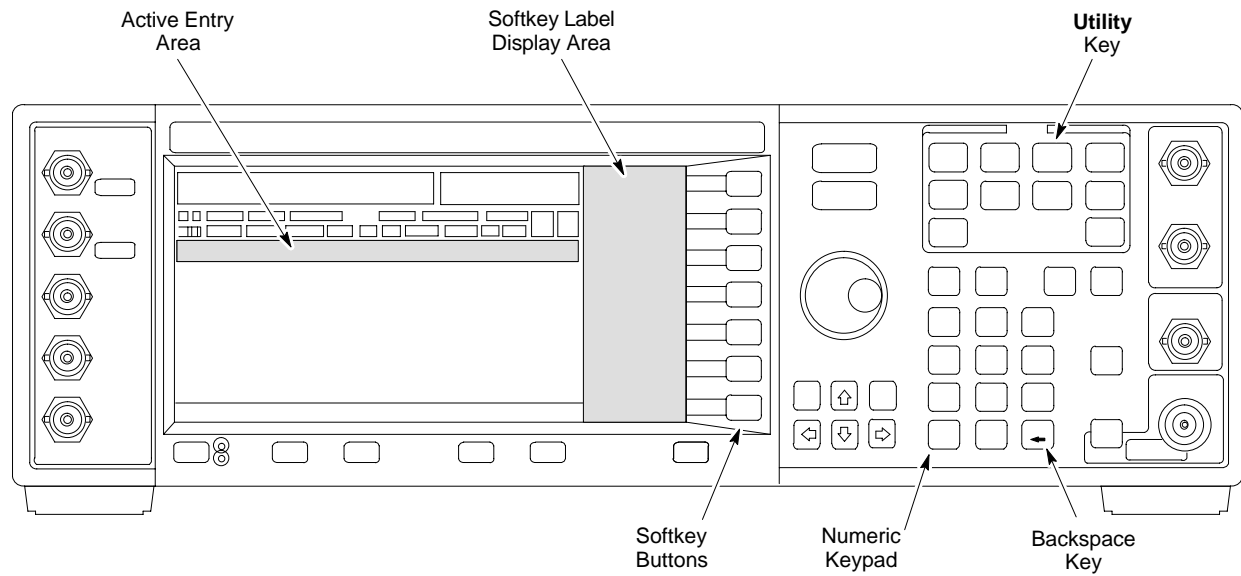

---

# Test Equipment Calibration

## Background



### CAUTION

To prevent damage to the test equipment, all Microcell transmit (TX) tests must be made using the 30 dB attenuator.

Proper test equipment calibration ensures that the test equipment and associated test cables do not introduce measurement errors, and that measurements are correct.

### NOTE

If the test set being used to interface with the BTS has been calibrated and maintained as a set, this procedure does not need to be performed. (Test Set includes LMF terminal, communications test set, additional test equipment, associated test cables, and adapters.)

This procedure must be performed *prior* to beginning the optimization. Verify all test equipment (including all associated test cables and adapters actually used to interface all test equipment and the BTS) has been calibrated and maintained as a set.



### CAUTION

If any piece of test equipment, test cable, or RF adapter, that makes up the calibrated test equipment set, has been replaced, re-calibration must be performed. Failure to do so can introduce measurement errors, resulting in incorrect measurements and degradation to system performance.



### IMPORTANT

Calibration of the communications test set (or equivalent test equipment) must be performed at the site before calibrating the overall test set. Calibrate the test equipment *after* it has been allowed to warm-up and stabilize for a *minimum of 60 minutes*.

These procedures access the LMF automated calibration routine used to determine the path losses of the supported communications analyzer, power meter, associated test cables, and (if used) antenna switch that make up the overall calibrated test set. After calibration, the gain/loss offset values are stored in a test measurement offset file on the LMF.

### Procedure to Calibrate Test Equipment

The calibrate test equipment function zeros the power measurement level of the test equipment item that is to be used for TX calibration and audit. If both a power meter and an analyzer are connected, only the power meter is zeroed.

Use the **Calibrate Test Equipment** menu item from the **Util** menu to calibrate test equipment. The test equipment must be selected before calibration can begin. Follow the procedure in Table 7-29 to calibrate the test equipment.

#### Prerequisites

Ensure the following prerequisites have been met before proceeding:

- Test equipment to be calibrated has been connected correctly for tests that are to be run.
- Test equipment has been selected.

**Table 7-29:** Procedure to Calibrate Test Equipment

Step	Action
1	From the <b>Util</b> menu, select <b>Calibrate Test Equipment</b> . A <b>Directions</b> window is displayed.
2	Follow the directions provided.
3	Click on <b>Continue</b> to close the <b>Directions</b> window. A status report window is displayed.
4	Click on <b>OK</b> to close the status report window.

### Calibration Without the LMF

Several test equipment items used in the optimization process require pre-calibration actions or calibration verification which are not supported by the LMF. Procedures to perform these activities for the applicable test equipment items are covered in this section.



## Test Equipment Calibration – continued

### Procedure to Calibrate R3465 Test Set

Follow the steps in Table 7-30 to configure and calibrate the R3465 communication test set.

Table 7-30: Procedure to Calibrate R3465	
Step	Action
1	<p><b>* IMPORTANT</b></p> <p>– Perform this calibration only after the analyzer has warmed-up and stabilized for a <i>minimum of 60 minutes</i>. Test equipment warm-up may vary depending on operating environment or initial temperature of unit upon turn-on. <i>Consult test equipment OEM documentation for additional information as required.</i></p> <p>Connect the male BNC to male N cable between the <b>CAL OUT</b> connector and the <b>INPUT 50 Ω</b> connector.</p>
2	Select <b>CW</b> .
3	Push the <b>SHIFT</b> and <b>CAL</b> pushbuttons.
4	Select <b>Cal All</b> in CRT menu. Internal calibration should complete in about 6 minutes.

### Procedure to Calibrate R3267 Test Set

Follow the steps in Table 7-31 to configure and calibrate the R3267 communication test set.

Table 7-31: Procedure to Calibrate R3267	
Step	Action
1	<p><b>* IMPORTANT</b></p> <p>– Perform this calibration only after the analyzer has warmed-up and stabilized for a <i>minimum of 60 minutes</i>. Test equipment warm-up may vary depending on operating environment or initial temperature of unit upon turn-on. <i>Consult test equipment OEM documentation for additional information as required.</i></p> <p>Connect the male BNC to male N cable between the <b>CAL OUT</b> connector and the <b>INPUT 50 Ω</b> connector.</p>
2	Select <b>CW</b> .
3	Push the <b>SHIFT</b> and <b>CAL</b> pushbuttons.
4	Select <b>Cal All</b> in CRT menu. Internal calibration should complete in about 6 minutes.

## Test Equipment Calibration – continued

### Procedure to Calibrate Agilent E4406A

Refer to Figure 7-27 and follow the procedure in Table 7-32 to perform the Agilent E4406A self-alignment (calibration).

Table 7-32: Perform Agilent E4406A Self-alignment (Calibration)	
Step	Action
1	In the <b>SYSTEM</b> section of the instrument front panel, press the <b>System</b> key. <ul style="list-style-type: none"><li>– The softkey labels displayed on the right side of the instrument screen will change.</li></ul>
2	Press the <b>Alignments</b> softkey button to the right of the instrument screen. <ul style="list-style-type: none"><li>– The softkey labels will change.</li></ul>
3	Press the <b>Align All Now</b> softkey button. <ul style="list-style-type: none"><li>– All other instrument functions will be suspended during the alignment.</li><li>– The display will change to show progress and results of the alignments performed.</li><li>– The alignment will take less than one minute.</li></ul>

Figure 7-27: Performing Agilent E4406A Self-alignment (Calibration)

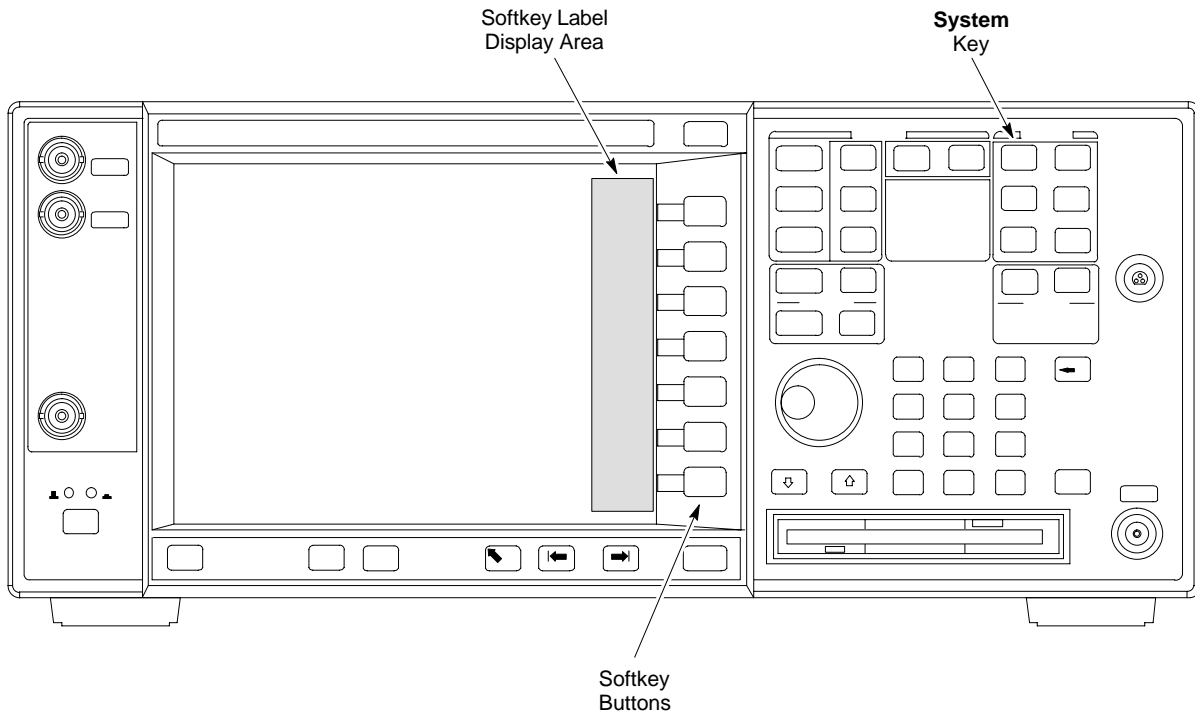

7

## Test Equipment Calibration – continued

### Procedure to Setup Advantest R3465 Test Equipment

Follow the steps outlined in Table 7-33 (for Advantest R3465) or Table 7-34 (for Advantest R3267) to set up test equipment prior to performing ATP tests.



#### IMPORTANT

LMF based measurements factor in cable and attenuator loss between the BTS and test equipment. No additional attenuation can be inserted as the additional losses would not be factored in.



#### IMPORTANT

If you are logged in to the BTS, you must log out prior to loading the special JCDMA software on a PCMCIA RAM card and inserting it in the Advantest R3465 PCMCIA slot. This must be done before using the Advantest R3465 test set for JCDMA tests.

**Table 7-33:** Procedure to Setup Advantest R3465 Test Equipment

Step	Action
1	If you have not already done so, interface the CDMA LMF computer to the BTS and login to the BTS.
2	Perform the following steps for the manual test procedure for Automated TX verification. Set up the communication test set by inserting the Automatic TX test PCMCIA card into the Advantest PCMCIA card reader slot A. (software version=97.10.07 rev 0001 or later). Perform the following steps to access and use the Advantest Automatic TX test screen:
3	Press the Remote LCL button (located below the CRT).
4	Press the Loader ON button (located below the CRT).
5	Press the <b>LOAD CRT</b> menu button.
6	Use the DISPLAY CONTROL knob to select CDMA_BSR.BAS and then press the knob.
7	Press the <b>RUN CRT</b> menu button after the <b>LOAD</b> pop-up disappears.
8	Wait for *Idle Free space to appear at the bottom of the CRT.
9	Refer to Figure 7-34 to set up test equipment. Verify that the coaxial cable from the appropriate TX connector on the BTS is connected to the test equipment RF input port via the in line 30 dB high power attenuator for MicroCell BTSs.

## Test Equipment Calibration – continued

### Procedure to Setup Advantest R3267 Test Equipment

<b>Step</b>	<b>Action</b>
1	If you have not already done so, interface the CDMA LMF computer to the BTS and login to the BTS.
2	Perform the following steps for the manual test procedure for Automated TX verification. Set up the communication test set by inserting the Automatic TX test PCMCIA card into the Advantest PCMCIA card reader slot <b>A</b> . (software revision 0.0.0.4 or later). Perform the following steps to access and use the Advantest Automatic TX test screen:
3	Press the Remote LCL button (located below the CRT).
4	Press the Loader ON button (located below the CRT).
5	Select <b>LOAD</b> on the CRT screen (button #6).
6	Use the DISPLAY CONTROL knob to select the REMOTE.BAS file, then press the knob.
7	Select <b>RUN</b> on the CRT screen (button #1).
8	Wait for *Idle Free space to appear at the bottom of the CRT.
9	Refer to Figure 7-34 to set up test equipment. Verify that the coaxial cable from the appropriate TX connector on the BTS is connected to the test equipment RF input port via the in line 30 dB high power attenuator for MicroCell BTSs.

# Test Equipment Selection

## Objective

The objective of this procedure is to select the test equipment used for BTS testing. The LMF must select the test equipment before it is used for BTS testing.

## Prerequisites

The following are prerequisites for test equipment selection:

1. Test equipment to be used has been connected as shown in Figure 7-16.
2. Power for the test equipment and GPIB box has been turned on.
3. LMF has been started (do not have to be logged in to the BTS).

## Procedure to Select Test Equipment

Follow the steps in Table 7-35 for test equipment selection

### NOTE

The test equipment can also be selected via a manual or automatic connection. Refer to the *CDMA LMF Operator's Guide, 68P64114A78* for the procedures.

**Table 7-35:** Procedure to Select Test Equipment

Step	Action
1	Select <b>Tools&gt;Options</b> from the menu. A <b>LMF Options</b> window appears.
2	Select the correct COM port from the <b>Comm Port</b> pick list (normally COM1).
3	Click on the <b>Auto-Detection</b> button if it is not enabled.
4	If the GPIB addresses are not displayed, enter the GPIB addresses in the box labeled <b>GPIB addresses to search</b> . <b>NOTE</b> When both a power meter and a communication test set are selected, the first item listed in the <b>GPIB addresses to search</b> box will be used for RF power measurements, e.g., TX calibration and audit. The address for a power meter is 13 and the address for a communications test set is 18. The numbers 13 and 18 must be included in the <b>GPIB address to search</b> box so the power meter (13) will be used for TX calibration and audit.
5	Click on the <b>Apply</b> button. The button will darken until the selection has been committed. A check mark will appear in the <b>Manual Configuration</b> section for detected test equipment items.
6	Click on the <b>Dismiss</b> button to close the <b>LMF Options</b> window.

## Test Equipment Selection – continued

### Selecting Test Equipment Automatically or Manually

Use **LMF Options** from the **Tools>Options** menu list to select test equipment automatically (using the autodetect feature) or manually.

A **Serial Connection** and a **Network Connection** tab are provided for test equipment selection. The **Serial Connection** tab is used when the test equipment items are connected directly to the LMF computer via a GPIB box (normal setup). The **Network Connection** tab is used when the test equipment is to be connected remotely via a network connection.

### Procedure to Manually Select Test Equipment in a Serial Connection Tab

Test equipment can be manually specified before, or after, the test equipment is connected. The LMF does not check to see if the test equipment is actually detected for manual specification. Follow the procedure in Table 7-36 to select test equipment manually.

**Table 7-36:** Procedure to Manually Select Test Equipment in a Serial Connection Tab

Step	Action
1	Select <b>Tools&gt;Options</b> . The <b>LMF Options</b> window appears.
2	Click on the <b>Serial Connection</b> tab (if not in the forefront).
3	Select the correct serial port in the <b>COMM Port</b> pick list (normally <b>COM1</b> ).
4	Click on the <b>Manual Specification</b> button (if not enabled).
5	Click on the check box corresponding to the test item(s) to be used.
6	Type the GPIB address in the corresponding <b>GPIB address</b> box (the default address is “1”). <b>Recommended Addresses</b> 1 = R3562 Test Source 13 = Power Meter 18 = CDMA Analyzer
7	Click on <b>Apply</b> (the button darkens until the selection has been committed). <b>NOTE</b> With manual selection, the LMF does not detect the test equipment to see if it is connected and communicating with the LMF.
8	Click on <b>Dismiss</b> to close the test equipment window.

## Test Equipment Selection – continued

### Procedure to Automatically Select Test Equipment in a Serial Connection Tab

When using the auto-detection feature to select test equipment, the LMF examines which test equipment items are actually communicating with the LMF. Follow the procedure in Table 7-37 to use the auto-detect feature.

**Table 7-37:** Procedure to Select Test Equipment Using Auto-Detect

Step	Action
1	Select <b>Tools&gt;Options</b> . The <b>LMF Options</b> window appears.
2	Click on the <b>Serial Connection</b> tab (if not in the forefront).
3	Select the correct serial port in the <b>COMM Port</b> pick list (normally COM1).
4	Click on <b>Auto–Detection</b> (if not enabled).
5	Type in the GPIB addresses in the box labeled <b>GPIB addresses to search</b> (the default address is “1”). <b>NOTE</b> When both a power meter and analyzer are selected, the first item listed in the <b>GPIB addresses to search</b> box is used for RF power measurements (i.e., TX calibration). The address for a the test source is 1; the address for the power meter is normally 13; and the address for a CDMA analyzer is normally 18. If 1, 13,18 are included in the <b>GPIB addresses to search</b> box, the power meter (13) is used for RF power measurements. If the test equipment items are manually selected, the CDMA analyzer is used only if a power meter is not selected.
6	Click on <b>Apply</b> . <b>NOTE</b> The button darkens until the selection has been committed. A check mark appears in the <b>Manual Configuration</b> section for detected test equipment items.
7	Click <b>Dismiss</b> to close the <b>LMF Options</b> window.

---

# Power Meter Calibration

## Objective

This procedure calibrates the power meter that will be used for cable calibration and BTS testing.

## Prerequisites

The following are prerequisites for power meter calibration:

1. The power meter is connected. Refer to Figure 7-16 in the “Test Equipment Selection” procedure.
2. Test equipment has been selected.

## Procedure to Calibrate the Power Meter

Follow the steps in Table 7-38 to calibrate the power meter.

<b>Table 7-38: Procedure to Calibrate the Power Meter</b>	
<b>Step</b>	<b>Action</b>
1	Click on <b>Util&gt;Calibrate Test Equipment</b> . A cable connection direction pop-up is displayed.
2	Follow the directions provided.
3	Click on the <b>OK</b> button to close the status results window.



---

# Test Cable Calibration

## Background

Proper test equipment setup ensures that all measurements are correct, and that test equipment and associated test cables do not introduce measurement errors. Motorola recommends repeating cable calibration prior to testing at each BTS site.

If not already done so, this procedure needs to be performed prior to beginning the ATP. Verify that all test equipment (including all associated test cables and adapters actually used to interface all test equipment and the BTS together) has been calibrated.



### CAUTION

In the event that any piece of test equipment, test cable, or RF adaptor is replaced that makes up the calibrated test equipment set, re-calibration should be performed. Failure to do so can introduce measurement errors, resulting in incorrect measurements or degradation to system performance.



### IMPORTANT

Calibration of the communications test set (or equivalent test equipment) must be performed at the site before calibrating the overall test set *after* it has been allowed to warm-up and stabilize for a minimum of 60 minutes.

## Purpose of Cable Calibration

This procedure accesses the LMF automated calibration routine used to determine the path losses of the supported communications analyzer, power meter, associated test cables, and (if used) RF Network making up the overall calibrated test set. After calibration, the gain/loss offset values are stored in a test measurement offset file on the LMF.

If you have obtained the test cable insertion loss values previously, you can manually enter them using the **Util>Edit>CableLoss>TX** or **RX** menu.

Do not use the manual method if you plan to run/have already run the cable calibration procedure.

### Procedure to do an Automated Cable Calibration

This procedure calibrates the cables that will be used for BTS testing. Follow the steps in Table 7-39 to calibrate the test cables. Refer to Figure 7-28.

#### Prerequisites

1. Test equipment has been connected as shown in Figure 7-16.
2. Power for the test equipment and GPIB box has been turned on.
3. LMF has been started and BTS has been logged into.
4. Inspect and verify the TX and RX antenna cabling for your BTS. Refer to the applicable “Antenna Cabling” procedure in chapter 6.

**Table 7-39: Automated Cable Calibration**

Step	Action
1	Click on the <b>Util&gt;Cable Calibration</b> menu item.
2	Select one of the following options in the <b>Cable Calibration</b> menu: <b>TX and RX CABLE CAL</b> , <b>TX CABLE CAL</b> , or <b>RX CABLE CAL</b> . <b>NOTE</b> Normally, the option <b>TX and RX CABLE CAL</b> is used so both the TX and RX cable configurations are calibrated. Use the <b>TX CABLE CAL</b> and <b>RX CABLE CAL</b> options only if one of the cable configurations needs to be calibrated.
3	Enter a channel value into the <b>Channel</b> box. The channel value is the channel that the BTS is being calibrated on, e.g., 170.
4	Click the <b>OK</b> button. A <b>Directions</b> pop-up is displayed for each step of the cable calibration.
5	Follow the directions displayed for each step. A status report window is displayed with the results of the cable calibration.
6	Click on <b>OK</b> to close the status report window.

# Test Cable Calibration – continued

**Figure 7-28:** Cable Calibration Test Setup (Motorola CyberTest, HP 8935, HP 8921, and Advantest R3465)

## SUPPORTED TEST SETS

### Motorola CyberTest

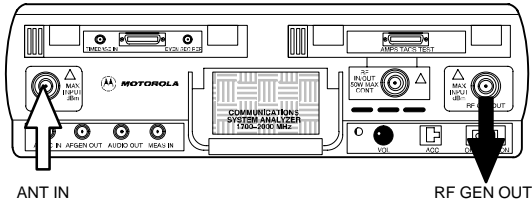

**Note:** The Directional Coupler is not used with the CyberTest Test Set. The TX cable is connected directly to the CyberTest Test Set.

A 10dB attenuator must be used with the short test cable for cable calibration with the CyberTest Test Set. The 10dB attenuator is used only for the cable calibration procedure, not with the test cables for TX calibration and ATP tests.

### Hewlett-Packard Model HP 8935

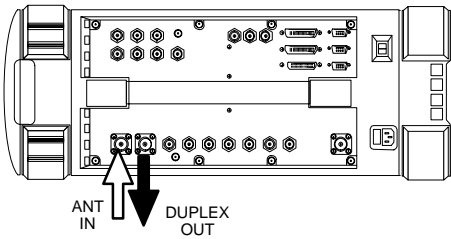

### Advantest Model R3465

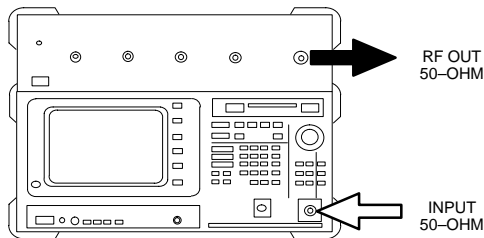

### Hewlett-Packard Model HP 8921A

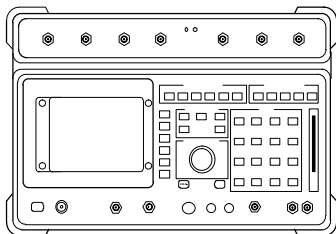

**Note:** For 800 MHz only. The HP8921A cannot be used to calibrate cables for PCS frequencies.

FW00089

## CALIBRATION SET UP

### A. SHORT CABLE CAL

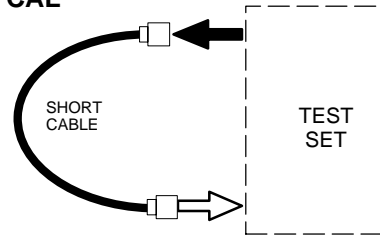

### B. RX TEST SETUP

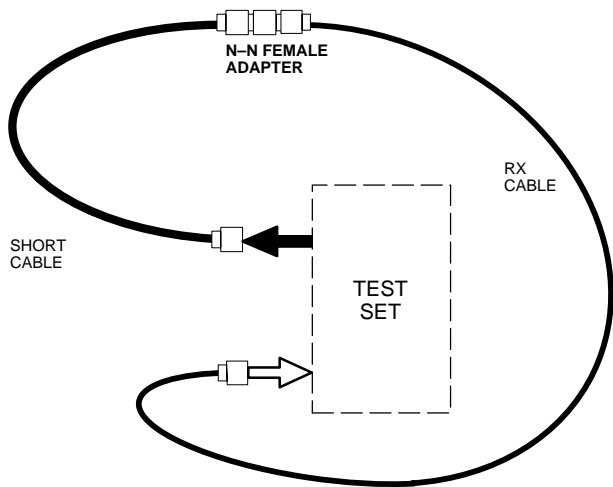

### C. TX TEST SETUP

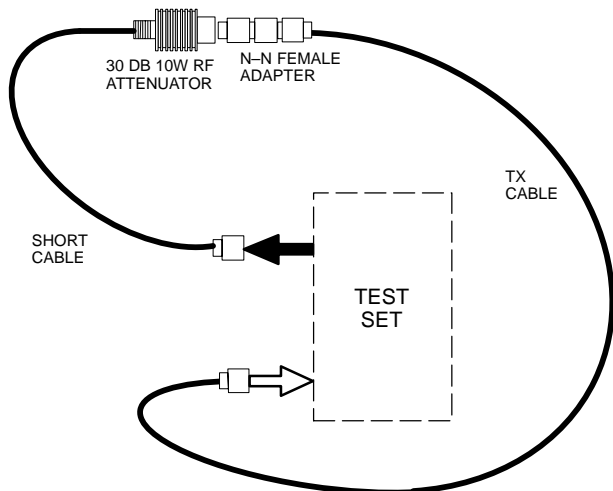

# Test Cable Calibration – continued

**Figure 7-29:** Cable Calibration Test Setup (Advantest R3267 and Agilent E4406A)

## SUPPORTED TEST SETS

**Agilent E4406A with E4432B  
Signal Generator**

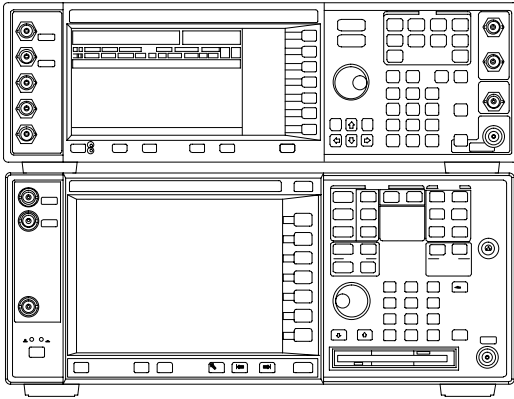

**Advantest Model R3267 with  
R3562 Signal Generator**

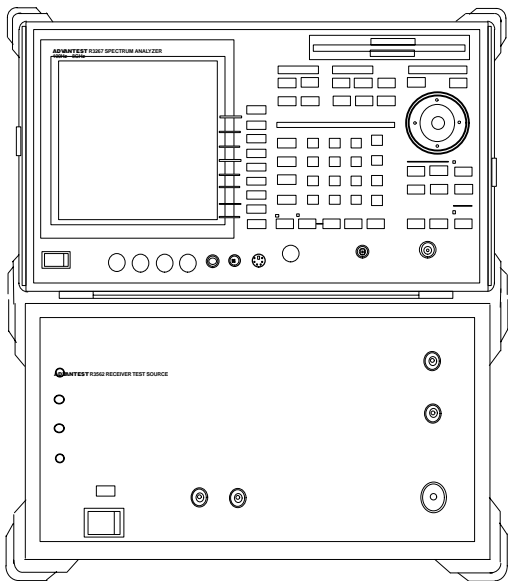

## CALIBRATION SET UP

### A. SHORT CABLE CAL

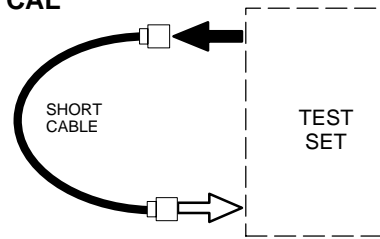

### B. RX TEST SETUP

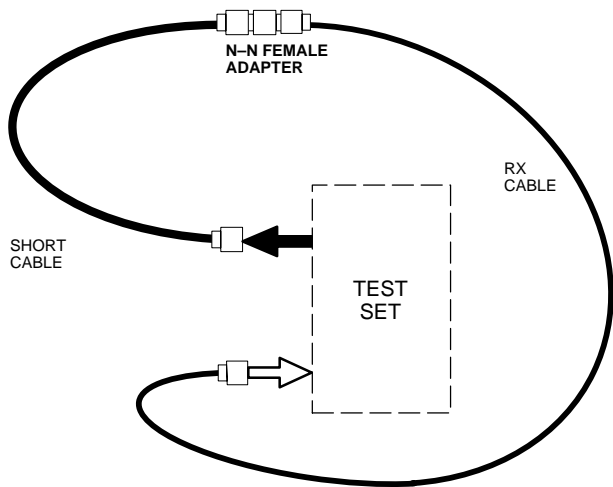

### C. TX TEST SETUP

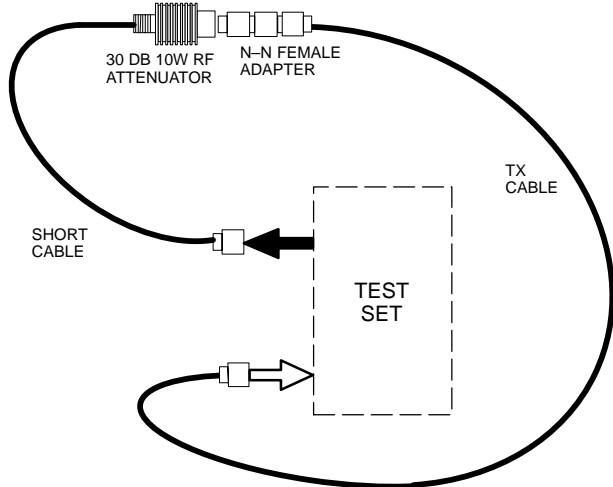

7

---

## Create CAL File

### Objective

Use this procedure to create a CAL file for the Calibration audit. You must do this procedure before the RF path audit.

### Background

The Create CAL File function gets the BLO data from the MAWI and creates/updates the CAL file for the BTS. If a CAL file does not exist, a new one is created. If a CAL file already exists, it is updated. The BTS is calibrated at the factory and normally does not require calibration after installation, so you must use the Create CAL File function to create a CAL file since TX calibration is not performed.

#### NOTE

The Create CAL File function only applies to selected (highlighted) MAWIs.

#### NOTE

The CBSC does not require a calibration file for operation of an SC300 BTS.

#### NOTE

The user is not encouraged to edit the CAL file as this action can cause interface problems between the BTS and the LMF. To manually edit the CAL file, you must first logout of the BTS. If you manually edit the CAL file and then use the Create CAL File function, the edited information is lost.

### Prerequisites

The following must be done before you run this test:

- The MAWI has the correct code load and data load.
- The MAWI is INS.
- The LMF is logged on to the BTS.

---

## Create CAL File – continued

### Procedure to Create a CAL File

Use the following procedure in Table 7-40 to create a CAL file.

<b>Table 7-40: Procedure to Create a CAL File</b>	
<b>Step</b>	<b>Action</b>
1	Log on to the BTS if you have not already done so.
2	Select the MAWI.
3	Click on the <b>Device</b> menu.
4	Click on the <b>Create Cal File</b> menu item. The status report window displays the results of the action.
5	Click <b>OK</b> .

#### **NOTE**

The `bts-#.cal` is located in the `wlmf\cdma\bts-#` folder (where # is the number of the BTS).

---

# Acceptance Tests

## Overview

This chapter describes the various TX and RX acceptance tests.

## TX Test Objective

The following tests will verify the TX antenna path. Output power control will also be verified. All tests will be performed using the power meter and communication test set. Measurements will be via the Antenna B connectors.

### NOTE

You must remove the antenna cables before you perform the ATP.

The BTS is keyed up to generate a CDMA carrier at 31 dBm.

## TX Tests

The following TX tests will be performed to verify the CDMA Forward Link.

### Near band & in band spurious emissions and occupied bandwidth

You will verify that the transmitted CDMA carrier waveform generated meets the Spurious Emissions specification (transmit spectral mask and Occupied Bandwidth as defined in IS95A/B) with respect to either a pre-determined test pattern or test pattern generated by using assigned cdf file values.

- +/- **750 kHz** from center frequency to +/- **1980 kHz** from center frequency – at least **-45 dBc**
- +/- **1980 kHz** from center frequency and out – at least **-60 dBc**
- all near band and out of band spurious emissions are verified to be less than or equal to **-60 dBc** relative to reference power (measured previously as total power).

### Waveform quality (Rho) and pilot time tolerance (offset)

You will verify that the transmitted Pilot channel waveform quality (rho) exceeds the minimum specified value in ARIB STD T53. *Rho* represents the correlation between actual and perfect CDMA modulation spectrum. 1.0000 represents 100% (or perfect correlation).

- Waveform quality (Rho) should be > **0.912 (-0.4 dB)**.

The Pilot Time Tolerance (Offset) is the difference between the CDMA analyzer measurement interval (based on the BTS system time reference) and the incoming block of transmitted data from the BTS (Pilot only, Walsh code 0).

- Pilot Time Tolerance (Offset) should be < **10 uS**. (< **3 uS** typical).

### CDMA carrier frequency verification

You will verify the frequency of the transmitted CDMA carrier signal to be within  $\pm 0.05$  ppm.

### Code domain power noise, pilot power, and total power

You will verify that the code domain noise floor of all unused Walsh codes within the CDMA spectrum measures  $< -27$  dB (with respect to total power). Pilot power will be verified to measure  $-7.04$  dB  $\pm 0.5$  dB (with respect to standard test patterns). Total power will be verified to measure  $+2/-4$  dB (with respect to CDF specific file parameters).

### BTS frequency accuracy

BTS frequency accuracy can be verified manually during normal operation by monitoring the 19.6608 MHz reference (19 MHz) from the Diagnostic Access Area. A frequency counter with an accuracy of  $\pm 0.005$  ppm can be used to check the BTS frequency accuracy.

## RX Test Objective

The following test will verify the RX antenna path(s).

All tests will be performed using the communication test set. Measurements will be via the Antenna A and Antenna B connectors.

## RX Tests

The following RX test will be performed to verify the CDMA Reverse Link.

### BTS RX sensitivity/frame erasure rate

The default test verifies the BTS sensitivity on all Traffic Channel elements (fullrate at 1% FER) at an RF input level of  $-117$  dBm on the RX antenna path.

#### NOTE

There are no pass/fail criteria associated with FER readings taken at level below  $-117$  dBm; other than to verify that the FER measurement reflects changes in RX input signal level.



# Subscriber Unit (SU) Test and Setup

## Objective

The following procedure is to test and verify the operation of the Subscriber Unit (SU). This procedure also contains instructions to program the NAM parameters into the SU prior to operation.

## Background

The integral Subscriber Unit (SU) provides a controlled method of terminating calls within the local BTS for diagnostic purposes. The SU's RF is connected to the forward port of the antenna directional couplers via distribution components to provide a hard-wired path. The SU performs a system-level test call with audio loopback functionality.

Control of the SU is only available remotely via the dial up modem (or locally via the MMI). The OMCR-based SALT script is not supported. The Subscriber Unit Distribution (SUD) is the board that provides RF splitting and attenuation for the subscriber unit RF signal. The SUD is an internal module.

## Procedure to Test and Verify SU

Follow the instructions in Table 7-41 to test and verify the operation of the SU.

**Table 7-41:** Procedure to Test and Verify the Subscriber Unit

Step	Action
1	Connect the LMF computer to the MMI/LMF connector. Refer to Figure 7-6.
2	If you have not already done so, logout of the BTS and exit the LMF. Wait 10 seconds before proceeding.
3	Establish an MMI communications session with the BTS. Refer to NO TAG.
4	Enter the <b>sndtype 0xa178</b> command to simulate an LMF session.
5	Make sure the unit has booted into the OOS_RAM state.
6	Enter the following command at the <code>sc300'x-1&gt;</code> prompt to enable SU response printing in the MMI session: <b>printf on</b>
. . . continued on next page	

## Subscriber Unit (SU) Test and Setup – continued

**Table 7-41:** Procedure to Test and Verify the Subscriber Unit

Step	Action
7	<p>Enter the following command at the <code>sc300'x-1&gt;</code> prompt to view the ESN number of the SU and the CAMPS version:</p> <p><b>su version</b></p> <p>The system will display the following output. Note that the ESN numbers will be different, but everything else will remain as shown below.</p> <pre>sc300'x-1&gt;su version  COMMAND ACCEPTED:  su version  *****su version***** Model  :+GMM:  C401M GMIinfo  :+GMI:  SANYO Electric Co., Ltd. GMRinfo  :+GMR:  1.310 GOI_id  :+GOI: GSN_id  :+GSN:  1869FE88 GCAP_format  :+GCAP:  +CIS707, +MS, +ES, +FCLASS ESN:  0x1869FE88</pre>
8	<p>Press ENTER once to return to the <code>sc300'x-1&gt;</code> prompt. Proceed to the “Subscriber Unit Programming” procedure in Table 7-42.</p>

## Subscriber Unit (SU) Test and Setup – continued

### Procedure to Program SU NAM Parameters

Follow the instructions in Table 7-42 to program the SU NAM parameters.

**Table 7-42:** Procedure to Program the SU NAM Parameters

Step	Action
1	Enter the following command at the <code>sc300'x-1&gt;</code> prompt to turn the power to the SU on: <b>su power on</b>
2	Enter the following command at the <code>sc300'x-1&gt;</code> prompt to view the NAM parameters stored in the SU: <b>su nam show</b> The system will display the following typical output:  <pre>sc300'x-1&gt;su nam show COMMAND ACCEPTED:  su nam show  SU NAM CONFIG ----- Phone Number          8476324677 Station Class Mark    34 Access Overload Code  0 Security Code         48 Lock Code             123 Slot Cycle Index      2 System Id             1 Network Id            65535 IMSI 11 &amp; 12         11 IMSI MCC              111 CDMA Pri Channel A    76 CDMA Pri Channel B    76 CDMA Sec Channel A    872 CDMA Sec Channel B    872</pre> <p><b>NOTE</b> The NAM values shown above are for example only. You must enter site-specific NAM parameter values into the following commands.</p>
3	Enter the following command at the <code>sc300'x-1&gt;</code> prompt to program the Mobile Phone Number: <b>su nam min</b> <phone number>
4	Enter the following command at the <code>sc300'x-1&gt;</code> prompt to program the Access Overload Code: <b>su nam aoc</b> <access overload code>
5	Enter the following command at the <code>sc300'x-1&gt;</code> prompt to program the Slot Cycle Index: <b>su nam si</b> <slot cycle index>
... continued on next page	

---

## Subscriber Unit (SU) Test and Setup – continued

**Table 7-42:** Procedure to Program the SU NAM Parameters

Step	Action
6	Enter the following command at the <code>sc300'x-1&gt;</code> prompt to program the System ID: <b>su nam sid</b> <system ID>
7	Enter the following command at the <code>sc300'x-1&gt;</code> prompt to program the Mobile Country Code (MCC) and IMSI 11&12 (MNC) code: <b>su nam imsi</b> <mcc & IMSI> For example, if the MCC code is “11” and the MNC code is “23,” you would enter: <b>su nam imsi 1123</b>
8	Enter the following command at the <code>sc300'x-1&gt;</code> prompt to view the changes to the NAM table: <b>su nam show</b>
9	Enter the following command at the <code>sc300'x-1&gt;</code> prompt to download the NAM information into the mobile: <b>su nam update</b> Downloading the NAM parameters into the Mobile may take a few minutes.

# CDMA Operating Frequency Programming Information – North American Cellular Bands

## Objective

The following tables show each of the valid operating channels for North American PCS Bands and their corresponding transmit and receive frequencies.

## 1900 MHz PCS Channels

Figure 7-30 shows the valid channels for the North American PCS 1900 MHz frequency spectrum.

**Figure 7-30:** North America PCS Frequency Spectrum (CDMA Allocation)

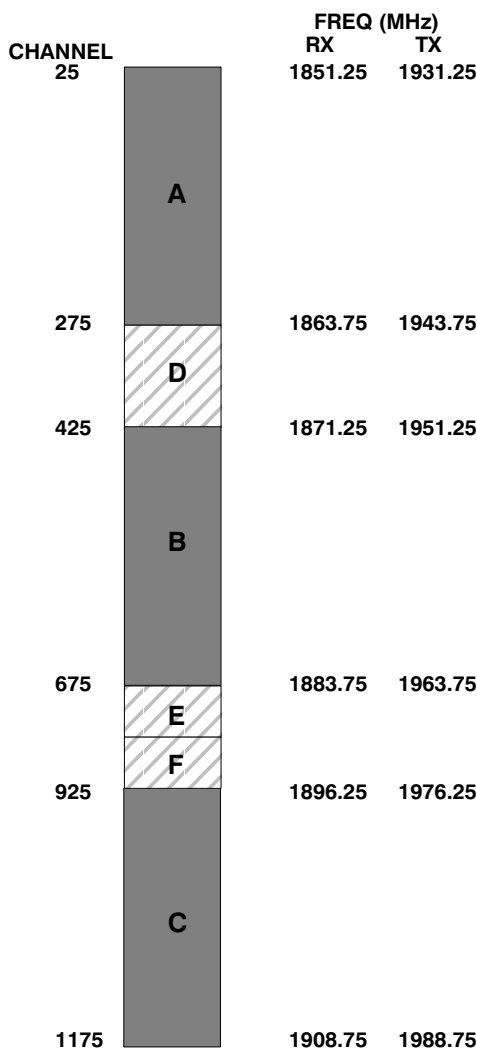

FW00463

# CDMA Operating Frequency Programming Information – North American Cellular Bands – continued

## Calculating 1900 MHz Center Frequencies

Table 7-43 shows selected 1900 MHz CDMA candidate operating channels, listed in both decimal and hexadecimal, and the corresponding transmit, and receive frequencies. Center frequencies (in MHz) for channels not shown in the table may be calculated as follows:

- $TX = 1930 + 0.05 * \text{Channel\#}$   
**Example:** Channel 262  
 $TX = 1930 + 0.05 * 262 = 1943.10 \text{ MHz}$
- $RX = TX - 80$   
**Example:** Channel 262  
 $RX = 1943.10 - 80 = 1863.10 \text{ MHz}$

Actual frequencies used depend on customer CDMA system frequency plan.

Each CDMA channel requires a 1.77 MHz frequency segment. The actual CDMA carrier is 1.23 MHz wide, with a 0.27 MHz guard band on both sides of the carrier.

Minimum frequency separation required between any CDMA carrier and the nearest NAMPS/AMPS carrier is 900 kHz (center-to-center).

**Table 7-43:** 1900 MHz TX and RX Frequency vs. Channel

Channel Number		Transmit Frequency (MHz) Center Frequency	Receive Frequency (MHz) Center Frequency
Decimal	Hex		
25	0019	1931.25	1851.25
50	0032	1932.50	1852.50
75	004B	1933.75	1853.75
100	0064	1935.00	1855.00
125	007D	1936.25	1856.25
150	0096	1937.50	1857.50
175	00AF	1938.75	1858.75
200	00C8	1940.00	1860.00
225	00E1	1941.25	1861.25
250	00FA	1942.50	1862.50
275	0113	1943.75	1863.75
300	012C	1945.00	1865.00
325	0145	1946.25	1866.25
350	015E	1947.50	1867.50
375	0177	1948.75	1868.75
400	0190	1950.00	1870.00
425	01A9	1951.25	1871.25
450	01C2	1952.50	1872.50
475	01DB	1953.75	1873.75
500	01F4	1955.00	1875.00
525	020D	1956.25	1876.25
550	0226	1957.50	1877.50
575	023F	1958.75	1878.75

... continued on next page



# CDMA Operating Frequency Programming Information – North American Cellular Bands – continued

**Table 7-43: 1900 MHz TX and RX Frequency vs. Channel**

Channel Number		Transmit Frequency (MHz)	Receive Frequency (MHz)
Decimal	Hex	Center Frequency	Center Frequency
600	0258	1960.00	1880.00
625	0271	1961.25	1881.25
650	028A	1962.50	1882.50
675	02A3	1963.75	1883.75
700	02BC	1965.00	1885.00
725	02D5	1966.25	1886.25
750	02EE	1967.50	1887.50
775	0307	1968.75	1888.75
800	0320	1970.00	1890.00
825	0339	1971.25	1891.25
850	0352	1972.50	1892.50
875	036B	1973.75	1893.75
900	0384	1975.00	1895.00
925	039D	1976.25	1896.25
950	03B6	1977.50	1897.50
975	03CF	1978.75	1898.75
1000	03E8	1980.00	1900.00
1025	0401	1981.25	1901.25
1050	041A	1982.50	1902.50
1075	0433	1983.75	1903.75
1100	044C	1985.00	1905.00
1125	0465	1986.25	1906.25
1150	047E	1987.50	1807.50
1175	0497	1988.75	1908.75

# CDMA Operating Frequency Programming Information – North American Cellular Bands – continued

## 800 MHz CDMA Channels

Figure 7-31 shows the valid channels for the North American cellular telephone frequency spectrum.

**Figure 7-31:** North American Cellular Telephone System Frequency Spectrum (CDMA Allocation).

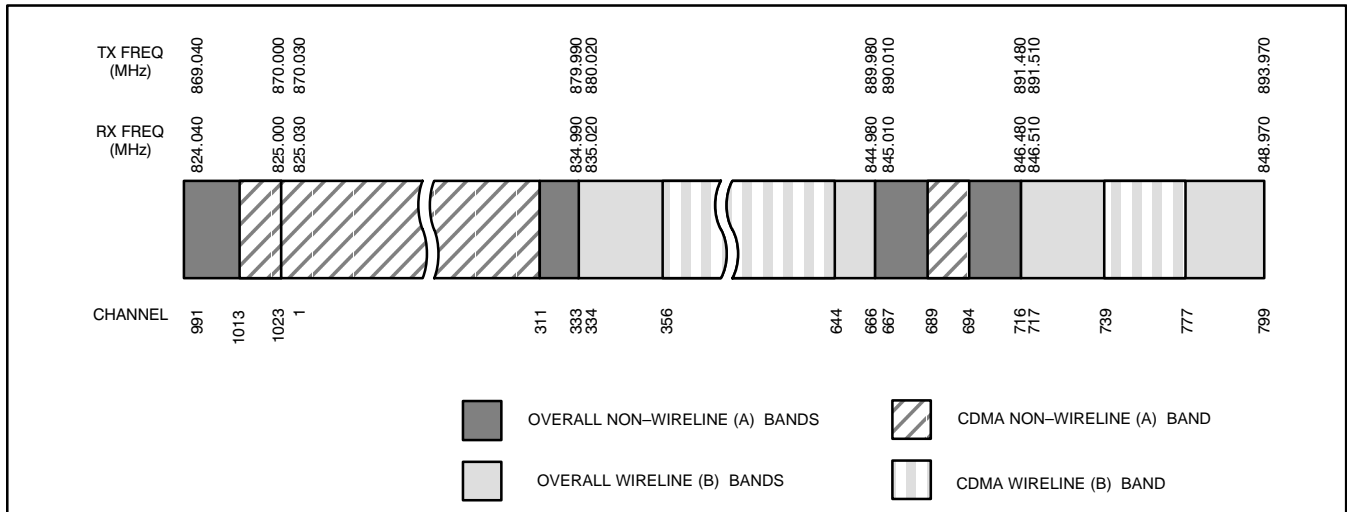

FW00402

## Calculating 800 MHz Center Frequencies

Table 7-44 shows selected 800 MHz CDMA candidate operating channels, listed in both decimal and hexadecimal, and the corresponding transmit, and receive frequencies. Center frequencies (in MHz) for channels not shown in the table may be calculated as follows:

- Channels 1–777  
 $TX = 870 + 0.03 * \text{Channel\#}$   
**Example:** Channel 262  
 $TX = 870 + 0.03 * 262 = 877.86 \text{ MHz}$
- Channels 1013–1023  
 $TX = 870 + 0.03 * (\text{Channel\#} - 1023)$   
**Example:** Channel 1015  
 $TX = 870 + 0.03 * (1015 - 1023) = 869.76 \text{ MHz}$
- $RX = TX - 45 \text{ MHz}$   
**Example:** Channel 262  
 $RX = 877.86 - 45 = 832.86 \text{ MHz}$

**Table 7-44:** 800 MHz TX and RX Frequency vs. Channel

Channel Number		Transmit Frequency (MHz) Center Frequency	Receive Frequency (MHz) Center Frequency
Decimal	Hex		
1	0001	870.0300	825.0300
25	0019	870.7500	825.7500
50	0032	871.5000	826.5000

... continued on next page



# CDMA Operating Frequency Programming Information – North American Cellular Bands – continued

**Table 7-44: 800 MHz TX and RX Frequency vs. Channel**

Channel Number		Transmit Frequency (MHz) Center Frequency	Receive Frequency (MHz) Center Frequency
Decimal	Hex		
75	004B	872.2500	827.2500
100	0064	873.0000	828.0000
125	007D	873.7500	828.7500
150	0096	874.5000	829.5000
175	00AF	875.2500	830.2500
200	00C8	876.0000	831.0000
225	00E1	876.7500	831.7500
250	00FA	877.5000	832.5000
275	0113	878.2500	833.2500
300	012C	879.0000	834.0000
325	0145	879.7500	834.7500
350	015E	880.5000	835.5000
375	0177	881.2500	836.2500
400	0190	882.0000	837.0000
425	01A9	882.7500	837.7500
450	01C2	883.5000	838.5000
475	01DB	884.2500	839.2500
500	01F4	885.0000	840.0000
525	020D	885.7500	840.7500
550	0226	886.5000	841.5000
575	023F	887.2500	842.2500
600	0258	888.0000	843.0000
625	0271	888.7500	843.7500
650	028A	889.5000	844.5000
675	02A3	890.2500	845.2500
700	02BC	891.0000	846.0000
725	02D5	891.7500	846.7500
750	02EE	892.5000	847.5000
775	0307	893.2500	848.2500
<b>NOTE</b>			
Channel numbers 778 through 1012 are not used.			
1013	03F5	869.7000	824.7000
1023	03FF	870.0000	825.0000

# TX Acceptance Tests

## Objective

Refer to Table 7-45 to perform a TX ATP test. This procedure assumes that the site specific CDF file is in the `wlmf\cdma\bts-#` folder.

The **ALL TX** list performs the following ATP tests:

1. TX Mask
2. Rho
3. Pilot Time Offset
4. Code Domain Power

## Prerequisites

You must successfully complete all the procedures outlined in previous chapters before you attempt to run an ATP.

## Procedure to Run TX ATP Test

Table 7-45: Procedure to Run TX ATP Test	
Step	Action
1	Set up test equipment for TX tests per Figure 7-32 or Figure 7-33.
2	Perform the following to run TX Acceptance Tests: <ul style="list-style-type: none"><li>– Select the MAWI.</li><li>– Click on the <b>Tests</b> menu</li><li>– Select <b>ALL TX</b>.</li></ul> <p><b>* IMPORTANT</b> The DPLL must be tracking either GPS or HSO.</p>

## Procedure to Run TX Tests Using Backup Synchronization (Sites Equipped With GPS)

Follow the steps in Table 7-46 to perform the TX test using backup synchronization.

Table 7-46: Procedure to Run TX Test Using Backup Synchronization	
Step	Action
1	If logged into the BTS with the LMF, disable the MAWI and logout. Enter the <b>sndtype 0x4003</b> command to change the state to OOS_RAM.
2	Open an MMI Communication session.
3	Enter the <b>status</b> command to verify that the BTS is in OOS_RAM status.
4	Enter the <b>sndtype 0xa178</b> command to simulate an LMF connection.
... continued on next page	

## TX Acceptance Tests – continued

**Table 7-46:** Procedure to Run TX Test Using Backup Synchronization

Step	Action
5	<p>At the MMI prompt, enter <b>dp11_info</b> and verify that GPS and HSO are good reference sources. Observe the following typical response.</p> <pre>current dp11 task state info: dp11 task state: DPLL_LOCKED global cdma time: enabled local cdma time: disabled Reference  Ref_Status Ref_select Even_select(DPLL's Ref source) GPS        TRUE        TRUE        TRUE HSO        TRUE        FALSE       FALSE FREERUN    FALSE       FALSE       FALSE 2SEC       FALSE       FALSE       FALSE</pre> <p>The Ref_Status for the GPS and HSO must be TRUE. The Ref_select must be TRUE and FALSE for the GPS and HSO, respectively.</p>
6	<p>Verify that the HSO takes over for the GPS by simulating a failure of the GPS through software. Enter the <b>gps_rx_debug nosats on</b> command at the MMI prompt to simulate the GPS losing all tracked satellites. Observe the following typical response.</p> <pre>FM: #2716 Ticks=00140aab pc=08137df4 nid=30003004 org=6 info=09e200270000 file=gps_misc.c line=3904 send gps no sats SET -seeing no tracked sats.</pre>
7	<p>Enter <b>dp11_info</b> at the MMI prompt to verify that the BTS is now using the HSO as the primary reference source. The Ref_select must be FALSE and TRUE for the GPS and HSO, respectively.</p>
8	<p>Enter the <b>dp11_status</b> command to display the current state of the DPLL. Observe the following typical response.</p> <pre>Current source set to: HSO reference DPLL control task state: DPLL track  DPLL status (not valid if using even sec src): c:6CD6 off: -9697314,25154,8669797 TK Mode cntr: 60 ip: 3, iq: -9 aip1: 9, aiq1: 4 aip2: 6, aiq2: -2 tip: 3, tiq: -9 integrator: -2511864</pre>
9	<p>Verify that the DPLL is “tracking” the HSO. The Current source set to field should read HSO reference. The DPLL control task state field should read DPLL track.</p>
10	<p>Exit the MMI communication session and login to the BTS with the LMF.</p>
11	<p>Select <b>Tests&gt;TX&gt;Pilot Time Offset</b> to verify that the BTS passes using the HSO as the backup synchronization source.</p>
12	<p>Logout of the BTS.</p>
<p>... continued on next page</p>	

---

## TX Acceptance Tests – continued

**Table 7-46:** Procedure to Run TX Test Using Backup Synchronization

Step	Action
13	If logged into the BTS with the LMF, then logout.
14	Open an MMI Communication session.
15	Enter the <b>status</b> command to verify that the BTS is in OOS_RAM status.
16	Enter the <b>sndtype 0xa178</b> command to simulate an LMF connection.
17	Enter the <b>gps_rx_debug nosats off</b> command at the MMI prompt to disable the simulation of the GPS losing tracked satellites.  <b>NOTE</b> The <b>gps_rx_debug</b> command simulates the “No Satellites Tracked” condition. In reality, the receiver is tracking satellites. However, the software is masking that information. Be sure to turn off the “No Satellites” condition after completing this test.
18	Follow the procedure in Table 7-11 (Synchronization Verification) to make sure the BTS is tracking the RGPS.

# TX Acceptance Tests – continued

**Figure 7-32: TX ATP Setup (CyberTest, HP 8935 and Advantest R3465)**

NOTE: THE DOTTED LINES REPRESENT THAT EITHER TX RF TEST CABLE CONNECTS TO BOTH COMMUNICATIONS TEST SET AND POWER METER

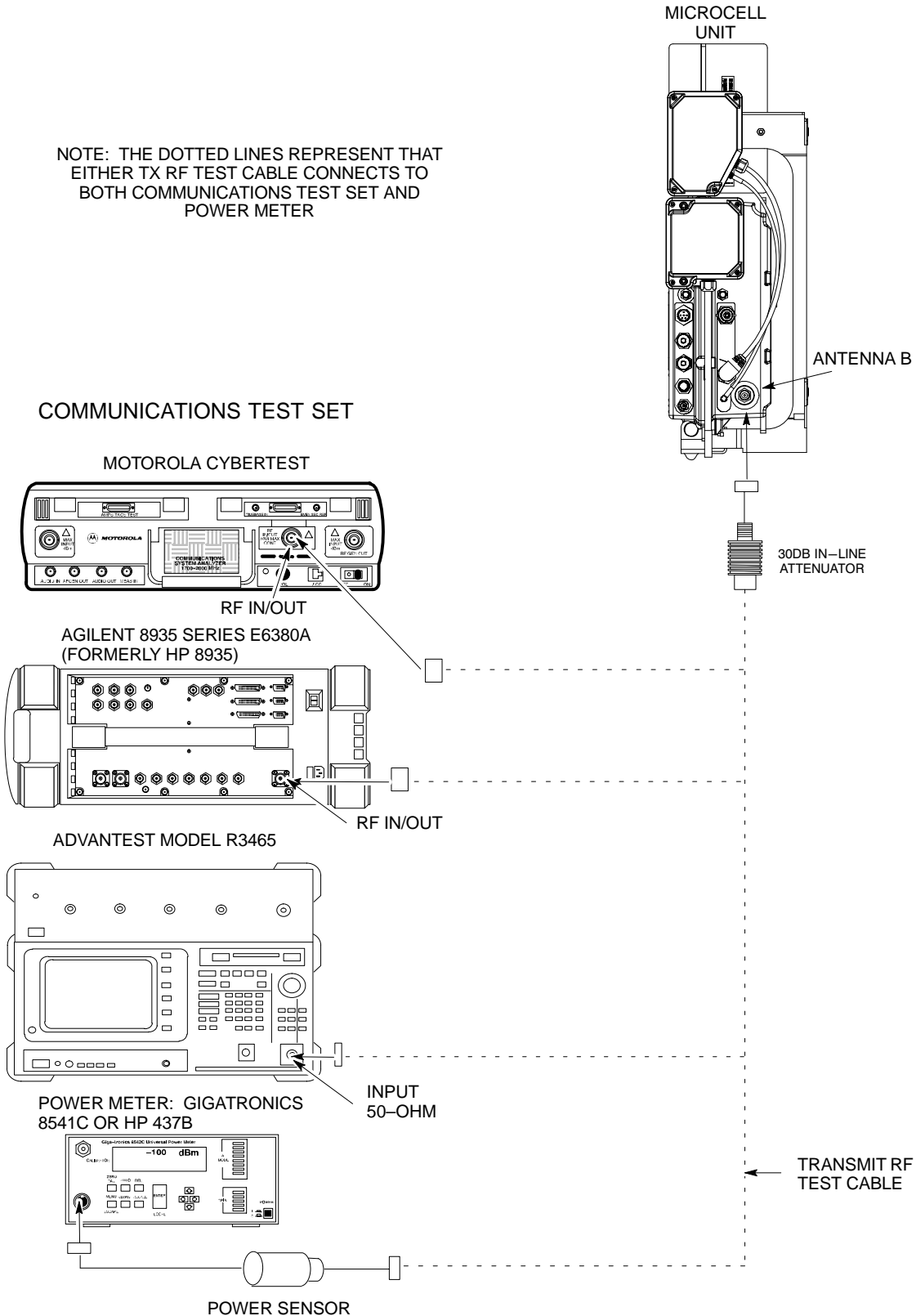

# TX Acceptance Tests – continued

**Figure 7-33: TX ATP Setup (HP 8921A)**

NOTE: THE DOTTED LINES REPRESENT THAT EITHER TX RF TEST CABLE CONNECTS TO BOTH COMMUNICATIONS TEST SET AND POWER METER

## COMMUNICATIONS TEST SET

HEWLETT-PACKARD MODEL HP 8921A W/PCS INTERFACE (FOR 1700 AND 1900 MHz)

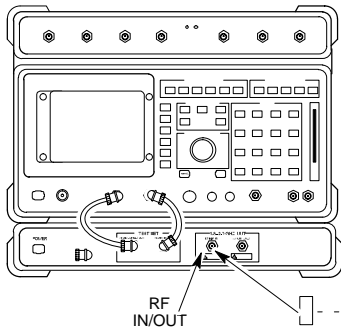

HEWLETT-PACKARD MODEL HP 8921A (FOR 800 MHz)

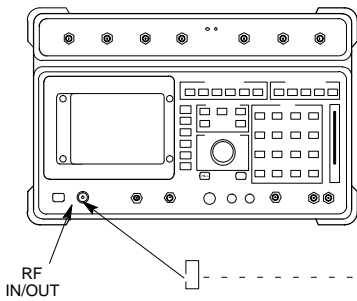

POWER METER: GIGATRONICS 8541C OR HP 437B

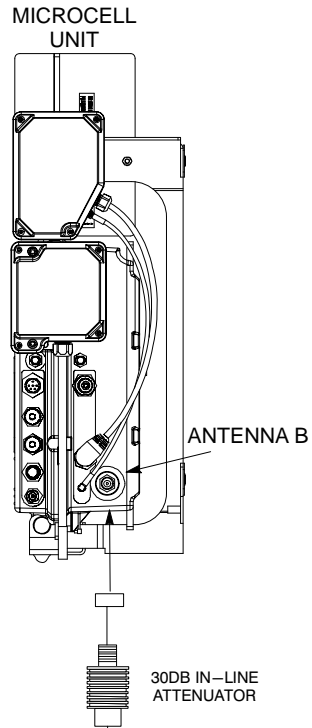
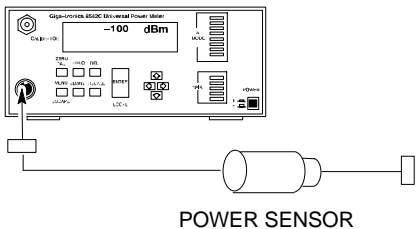

TRANSMIT RF TEST CABLE

7

# TX Acceptance Tests – continued

**Figure 7-34:** TX ATP Setup (Advantest R3267 and Agilent E4406A)

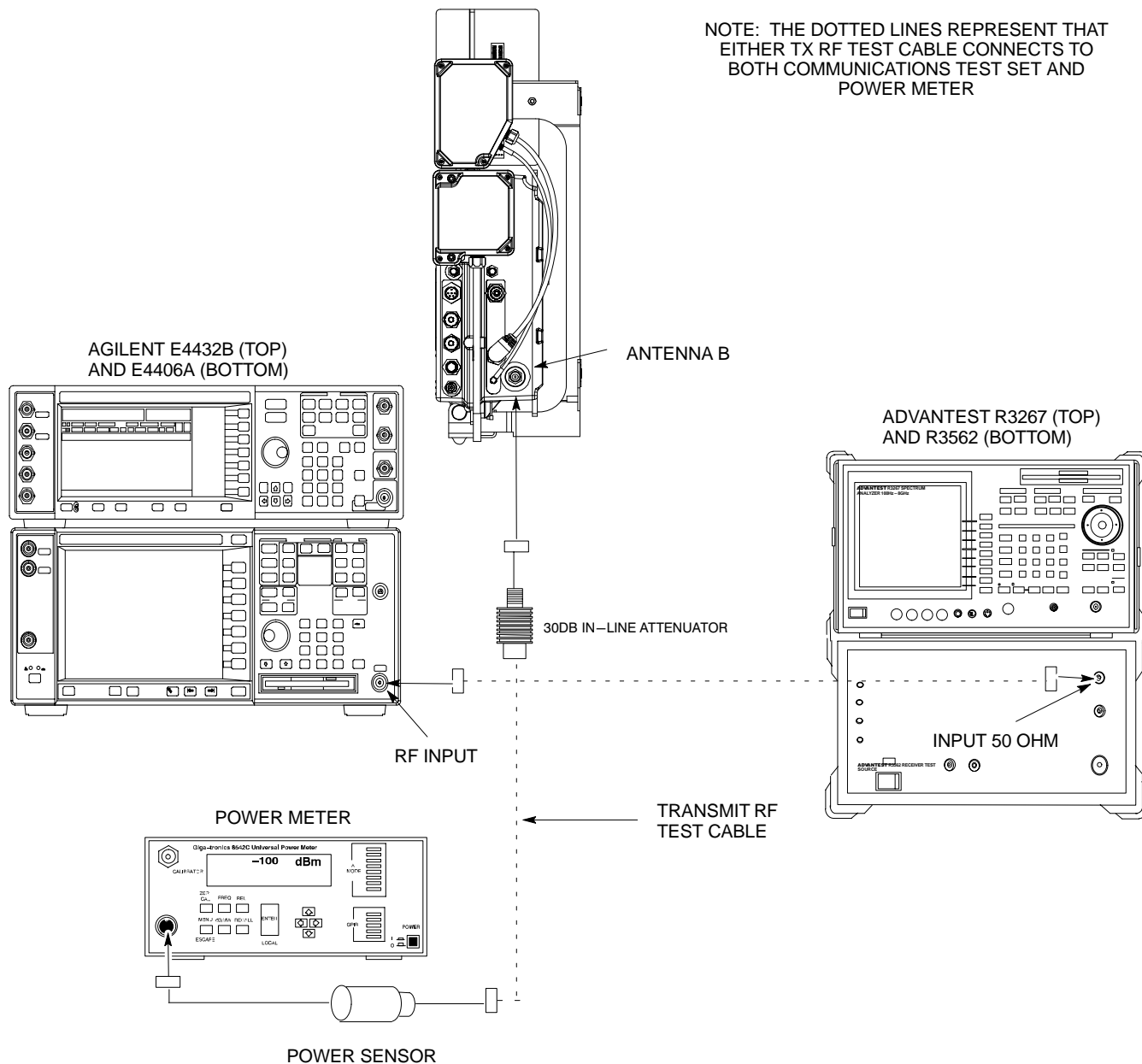

---

# RX Acceptance Tests

## Objective

This procedure assumes that the site specific CDF file is in the `wlmf\cdma\bts-#` folder.

## Prerequisites

You must successfully complete all the procedures outlined in previous chapters before you attempt to run an ATP.

## Procedure to Run RX ATP Test

Refer to Table 7-47 to perform an RX ATP test. This procedure assumes that the site specific CDF file is in the `wlmf\cdma\bts-#` folder.

**Table 7-47:** Procedure to Run RX ATP Test

Step	Action
1	Set up test equipment per Figure 7-35, Figure 7-36, or Figure 7-37.
2	Terminate diversity RX antenna inputs on the unit.
3	Enter the following commands to run the RX Acceptance Tests. <ul style="list-style-type: none"><li>– Select the MAWI.</li><li>– Select <b>Tests&gt;ALL RX</b>.</li></ul> <p><b>NOTE</b> The LMF refers to the antennas as Main and Diversity. The Main is Antenna B and the Diversity is Antenna A.</p> <p><b>NOTE</b> Select <b>Both</b> in the <b>RX Branch</b> pick list if a diversity antenna is used.</p>



# RX Acceptance Tests – continued

**Figure 7-35:** RX ATP Setup (CyberTest, HP 8935, and Advantest R3465)

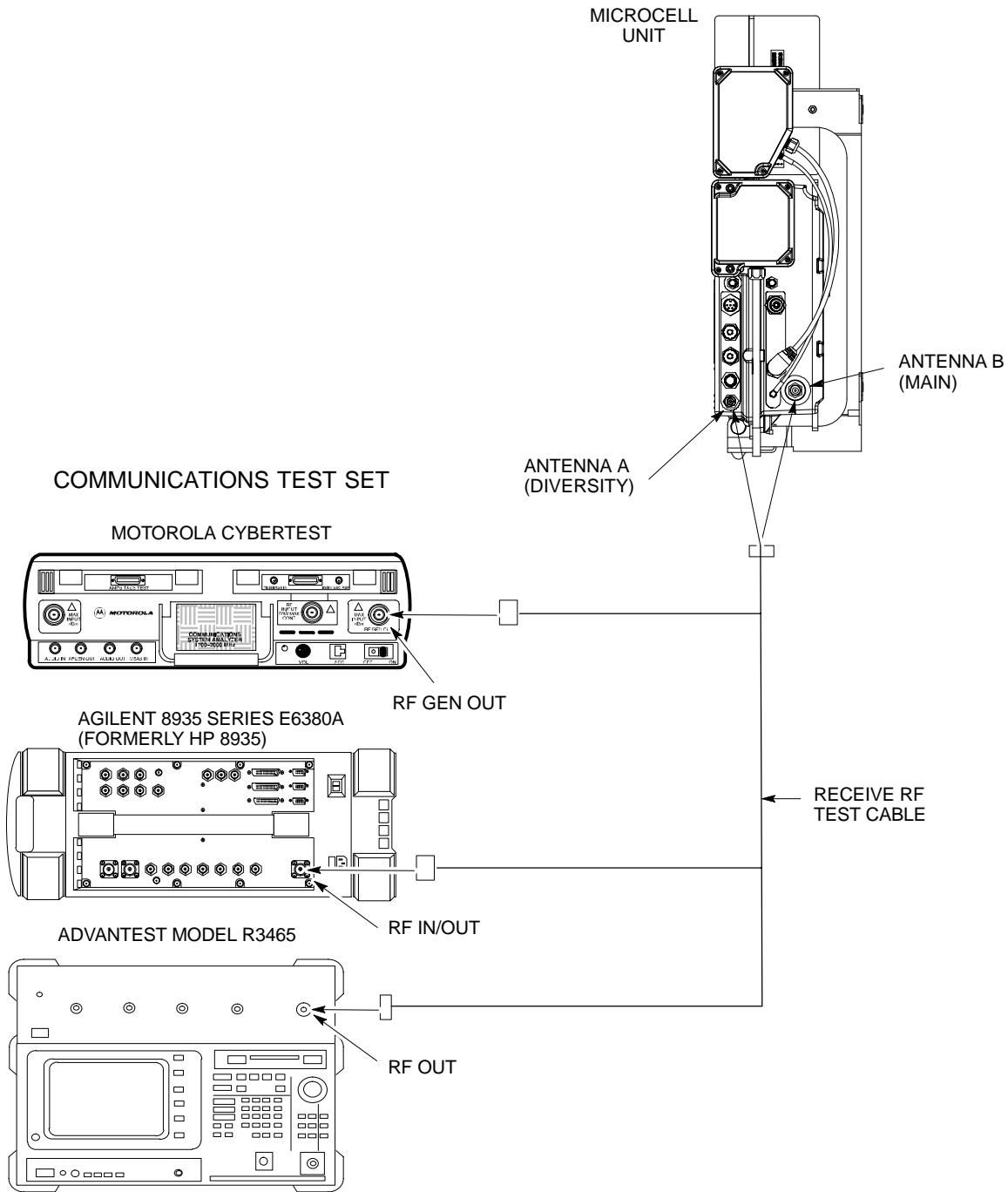

# RX Acceptance Tests – continued

Figure 7-36: RX ATP Setup (HP 8921A)

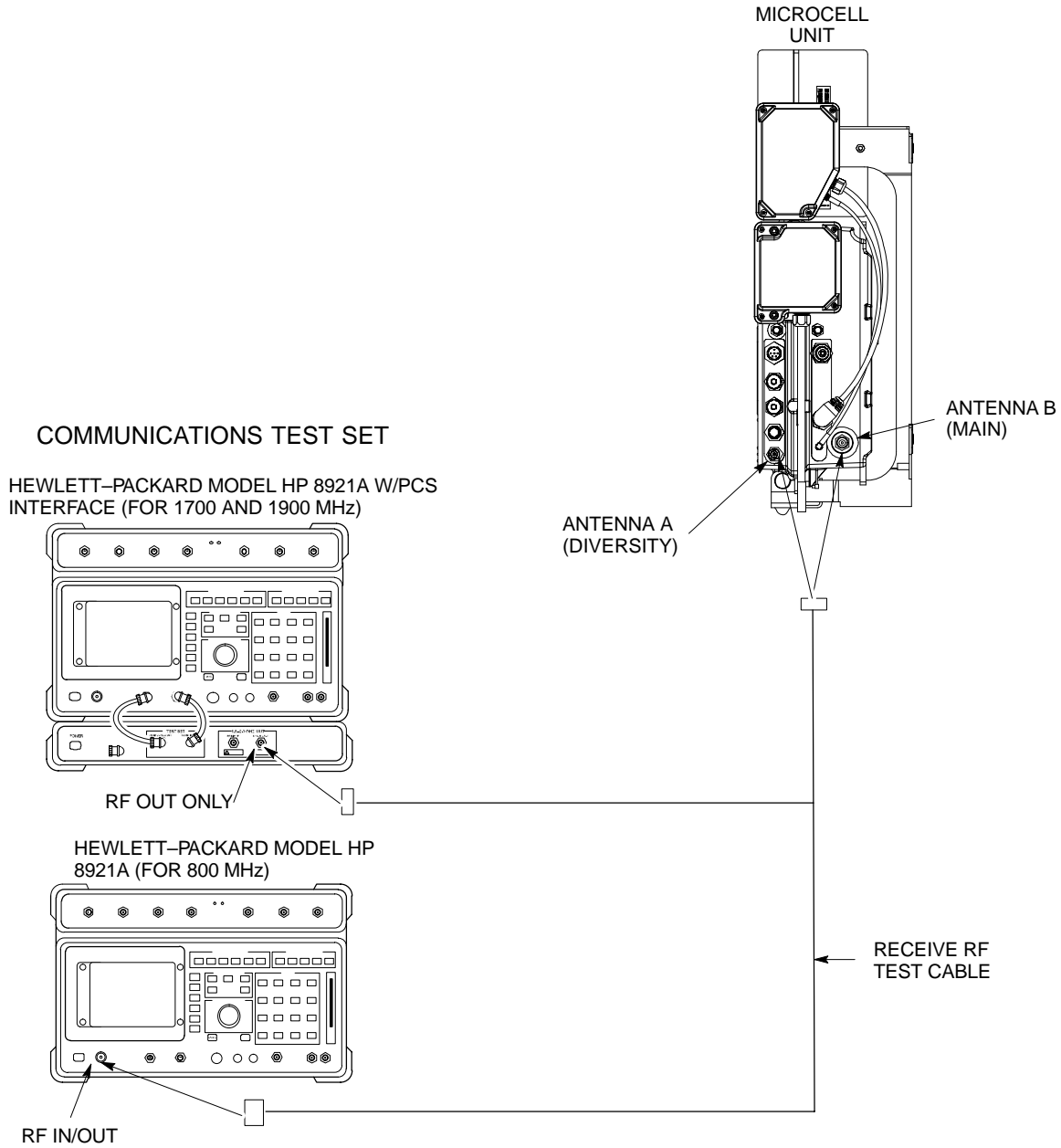

7

# RX Acceptance Tests – continued

**Figure 7-37: RX ATP Setup (Advantest R3267 and Agilent E4406A)**

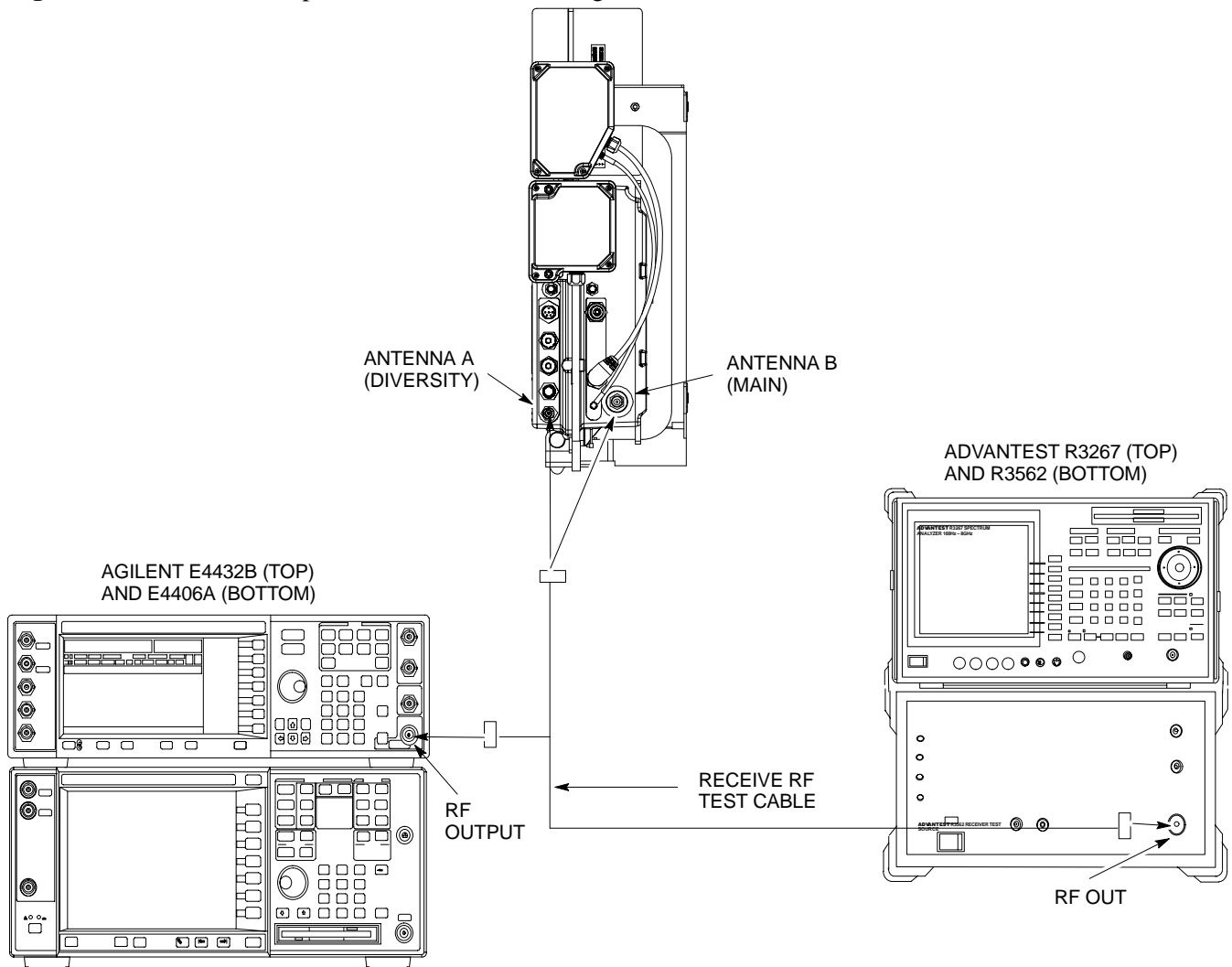

# Generate an ATP Report

## Background

Each time an ATP test is run, an ATP report is updated to include the results of the most recent ATP tests if the **Save Results** button is used to close the status report window. The ATP report *will not* be updated if the status reports window is closed with use of the **Dismiss** button.

## ATP Report

A separate report is created for each BTS and includes the following for each test:

- Test name
- PASS or FAIL
- Description information (if applicable)
- MAWI number
- Channel number
- Carrier number
- Sector number
- Upper test limit
- Lower test limit
- Test result
- Time stamp
- Details/Warning information (if applicable)

## Procedure to Run ATP Report

Follow the procedures in Table 7-48 to view and create a printable file for the ATP report of a BTS.

**Table 7-48:** Procedure to Generate an ATP Report

Step	Action
1	Click on the <b>Login</b> tab if it is not in the forefront.
2	Select the desired BTS from the <b>Available Base Stations</b> pick list.
3	Click on the <b>Report</b> button.
4	Start the report if desired by clicking on a column heading.
5	Click on the <b>Dismiss</b> button if you do not want to create a printable file copy.
6	To create a printable file, select the desired file type in the picklist and then click on the <b>Save</b> button.

### NOTE

Refer to the LMF help screens, or the *CDMA LMF Operator's Guide*, 68P64114A21, for information on how to print an ATP report.

# Copy LMF CAL File to CBSC

## Objective

The following procedure is to copy the LMF CAL file to the CBSC after performing an ATP.

## Background

After you perform the ATP you must move a copy of the CAL file for the BTS from the LMF to the CBSC. This is normally done by putting a copy of the CAL file on a floppy disk and then using the floppy disk to move the CAL file to the CBSC.

### Prerequisites

- A DOS formatted 1.44 MB 3 1/2-in. floppy disk is necessary to do this procedure.
- The ATP and Audit procedures have successfully been performed.
- The Create CAL File procedure was performed.
- You logged out of the BTS.

## Procedure to Copy CAL Files from LMF to a Diskette

Follow the procedure in Table 7-49 to copy CAL files from an LMF computer to a 3.5 diskette.

Table 7-49: Procedure to Copy CAL Files from LMF to a Diskette	
Step	Action
1	Insert a diskette into your Windows A: drive.
	<b>NOTE</b> If your diskette has not been formatted, format it using Windows. The diskette must be DOS formatted before copying any files. Consult your Windows/DOS documentation or online help on how to format diskettes.
2	Click on the bold <b>Start</b> button to launch the <b>Windows Explorer</b> program from your <b>Programs</b> menu list.
3	Click on your C: drive
4	Double click on the wlmf folder.
5	Double-click on the CDMA folder
6	Double click on the btS-# folder for the file you want to copy.
7	Drag the file (for example, BTS-#.cal, BTS-#.txt, BTS-#.htm, BTS-#.xls) to the 3-1/2-in. floppy (A:) icon on the top left of the screen and release the mouse button.
8	Repeat step 6 and 7 until you have copied each file desired and close the Windows Explorer program by selecting <b>Close</b> from the <b>File</b> menu option.

## Copy LMF CAL File to CBSC – continued

### Procedure to Copy CAL Files from Diskette to the CBSC

Follow the procedures in Table 7-50 to copy CAL file from a diskette to the CBSC.

Table 7-50: Procedure to Copy CAL Files from Diskette to the CBSC	
Step	Action
1	Log in to the CBSC on the OMC-R Unix workstation using your account name and password.
2	Place your diskette containing calibration file(s) in the workstation diskette drive.
3	Type in <code>eject -q</code> and press the Enter key.
4	Type in <code>mount</code> and press the Enter key. <b>NOTE</b> <ul style="list-style-type: none"><li>• Check to see that the message <code>floppy/no_name</code> is displayed on the last line.</li><li>• If the <b>eject</b> command was previously entered, <code>floppy/no_name</code> will be appended with a number. Use the explicit <code>floppy/no_name</code> reference displayed.</li></ul>
5	Type in <code>cd /floppy/no_name</code> and press the Enter key.
6	Type in <code>ls -lia</code> and press the Enter key. Verify that the <code>bts-#.cal</code> file is on the diskette.
7	Type in <code>cd</code> and press the Enter key.
8	Type in <code>pwd</code> and press the Enter key. Verify you are in your home directory ( <code>/home/&lt;name&gt;</code> ).
9	With <i>Solaris versions of Unix</i> , create a Unix-formatted version of the <code>bts-#.cal</code> file in your home directory by entering the following command: <code>dos2unix /floppy/no_name/bts-#.cal bts-#.cal</code> and press the Enter key (where # is BTS number). <b>NOTE</b> Other versions of Unix do not support the <code>dos2unix</code> command. In these cases, use the Unix <code>cp</code> (copy) command. The <i>copied</i> files will contain DOS line feed characters which must be edited out with a Unix text editor.
10	Type in <code>ls -l *.cal</code> and press the <b>Enter</b> key. Verify the <code>cal</code> files have been copied.
11	Type in <code>eject</code> and press the <b>Enter</b> key.
12	Remove the diskette from the workstation.

---

## Prepare to Leave the Site

### Remove External Test Equipment

Perform the procedure in Table 7-51 to disconnect the test equipment and prepare the BTS for active service.

Table 7-51: Remove External Test Equipment	
Step	Action
1	Disconnect all test equipment from the antenna connectors on the BTS.
2	Reconnect and visually inspect all antenna feed lines on the BTS.
3	Disconnect all test equipment from the diagnostic access area.

### Reset and Initialize Site Remotely

The BTS should not be left with data and code loaded from the CDMA LMF. The configuration data and code loads used for normal operation could be different from those stored in the CDMA LMF files. By resetting the BTS, the required data and code can be loaded from the CBSC when spans are again active.

To reset the BTS and have the OMCR/CBSC bring up the site remotely, perform the procedure in Table 7-52.

Table 7-52: Reset BTS and Remote Site Initialization	
Step	Action
1	Terminate the CDMA LMF session by following the procedures in Table 7-54.
2	Use the AC and DC power breakers to cycle BTS power off and on.
3	Notify the OMCR/CBSC to take control of the site and download code and data to the BTS.
4	Verify the CBSC can communicate with the MAWI.

### Bring BTS into Service with the CDMA LMF



#### IMPORTANT

Whenever possible, have the OMCR/CBSC enable the BTS.

If code and/or data could not be loaded remotely from the OMCR/CBSC, follow the steps outlined in Table 7-53 *as required* to bring the BTS from the OOS to INS mode.

## Prepare to Leave the Site – continued

**Table 7-53:** Procedure to Bring BTS into Service

Step	Action
1	On the CDMA LMF, select the MAWI.
2	Click on <b>Device</b> from the menu bar.
3	Click on <b>Enable</b> from the <b>Device</b> menu. A status report window is displayed.
4	Click <b>Cancel</b> to close the transceiver parameters window, if applicable.
5	Click <b>OK</b> to close the status report window. The selected devices that successfully change to INS change color to green.

### Terminate LMF Session/Remove Terminal

Perform the procedure in Table 7-54 to terminate the LMF session and remove the CDMA LMF computer.

**Table 7-54:** Procedure to Remove LMF

Step	Action
	<b>! CAUTION</b> Do not power down the CDMA LMF terminal without performing the procedure below. Corrupted/lost data files may result.
1	Log out of all BTS sessions and exit CDMA LMF by clicking on the <b>File</b> selection in the menu bar and selecting <b>Exit</b> from the <b>File</b> menu list.
2	Click <b>Yes</b> in the <b>Confirm Logout</b> pop-up message which appears.
3	In the Windows Task Bar, click <b>Start</b> and select <b>Shutdown</b> .
4	Click <b>Yes</b> when the Shut Down Windows message appears.
5	Wait for the system to shut down and the screen to go blank.
6	Disconnect the CDMA LMF terminal serial cable from the BTS.
7	Disconnect the CDMA LMF terminal serial port, the RS-232-IEEE488 converter and the GPIB cables as required for equipment transport.



---

## Prepare to Leave the Site – continued

### Replace Diagnostic Access Cover

Use a T20 Torx tamper bit to tighten the two tamper-resistant M4 screws holding the cover. Torque to 10 in-lb. Refer to Figure 7-38.

**Figure 7-38:** How To Replace The Diagnostic Access Cover

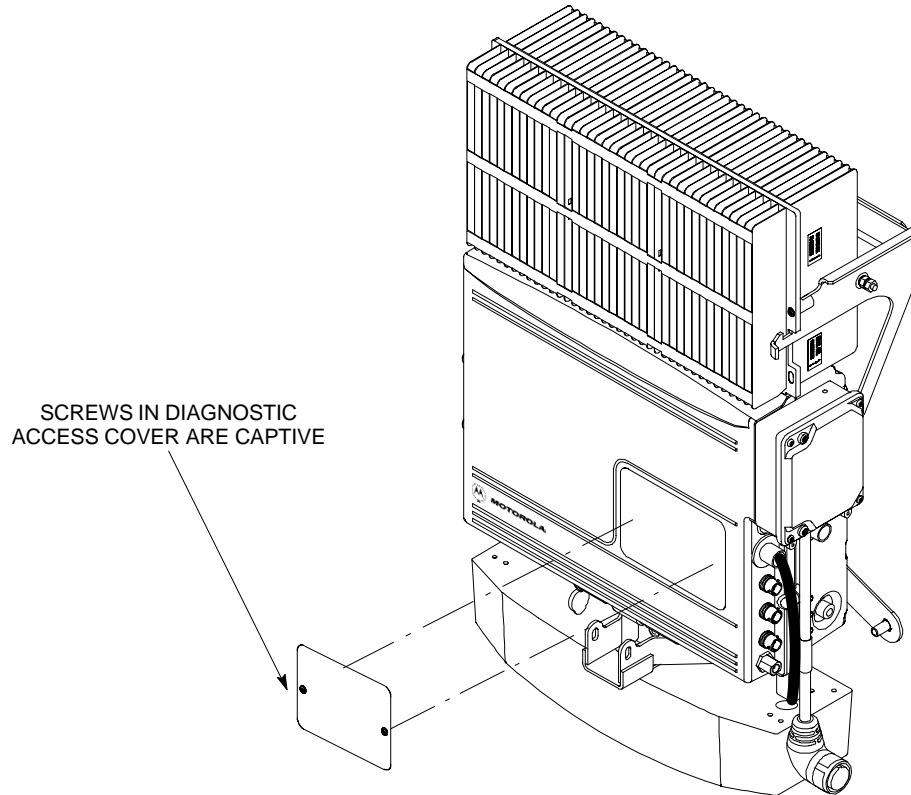

### Replace Solar Cover

Replace the solar cover. Refer to the “Powering on Unit and Mounting the Solar Cover” procedure in Chapter 5.



# Chapter 8: Field Replaceable Unit (FRU) Procedures

## Table of Contents

---

Field Replaceable Unit (FRU) Overview .....	8-1
Overview .....	8-1
List of FRUs .....	8-1
Shut Down & Restoring BTS Signaling .....	8-3
Objective .....	8-3
Accessing the OMCR CLI window .....	8-3
Shut Down Signaling Functions .....	8-3
Restore Signaling Operations .....	8-10
Site I/O Junction Box Replacement Procedure .....	8-14
Objective .....	8-14
System Impact/Considerations .....	8-14
Required Tools and Materials .....	8-14
Procedure to Replace Site I/O Junction Box .....	8-14
Site I/O Junction Box Location Diagram .....	8-16
Short Duration Battery Replacement Procedures .....	8-17
Objective .....	8-17
Required Tools and Materials .....	8-17
Procedure to Replace Short Duration Battery .....	8-17
Remote GPS Replacement Procedure .....	8-19
Objective .....	8-19
Required Tools and Materials .....	8-19
Procedure to Replace Remote GPS .....	8-19
Full Unit Replacement Procedures .....	8-21
Objective .....	8-21
System Impact/Considerations .....	8-21
Required Tools and Materials .....	8-21
Procedure to Replace Failed Unit .....	8-21



# Field Replaceable Unit (FRU) Overview

## Overview

The purpose of this chapter is to provide the Field Replaceable Unit (FRU) replacement procedures for the unit. Figure 8-1, Figure 8-2 and Figure 8-3 show the FRUs associated with the unit.

## List of FRUs

The following is a list of FRUs for the unit:

1. Site I/O Junction Box with Primary Surge Suppressor – Kit T450AE
2. Site I/O Junction Box without Primary Surge Suppressor – Kit T450AA
3. RGPS Head – Kit T472AP
4. Short Duration Battery – Kit T348AE
5. Primary Surge Suppressor – Kit T449AA
6. AC Installation Box – Kit T449AB

### MicroCell units

1. A Band BTS with HSO – Kit SG1478AA
2. A Band BTS without HSO – Kit SG1479AA
3. B Band BTS with HSO – Kit SG1486AA
4. B Band BTS without HSO – Kit SG1487AA
5. Solar Cover – Kit T451AA
6. Fin Cover – Kit T389AB

**Figure 8-1:** FRU Items

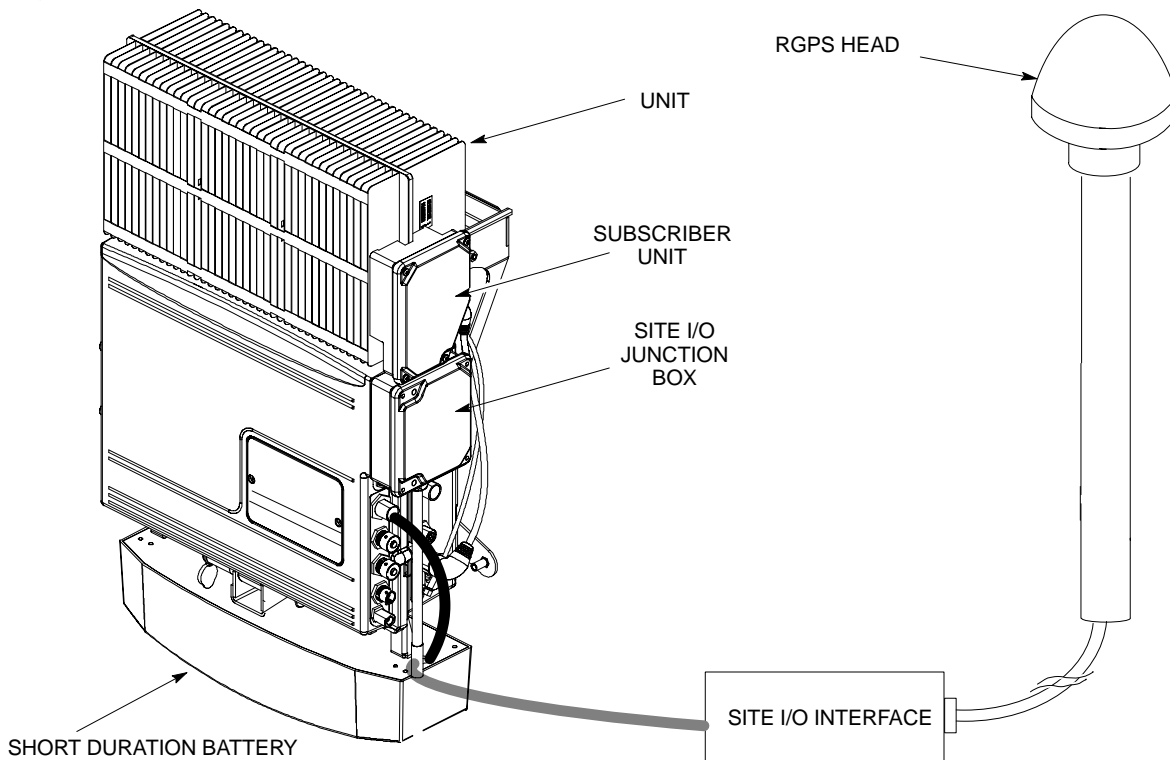

Figure 8-2: Front and Back Solar Covers for MicroCell

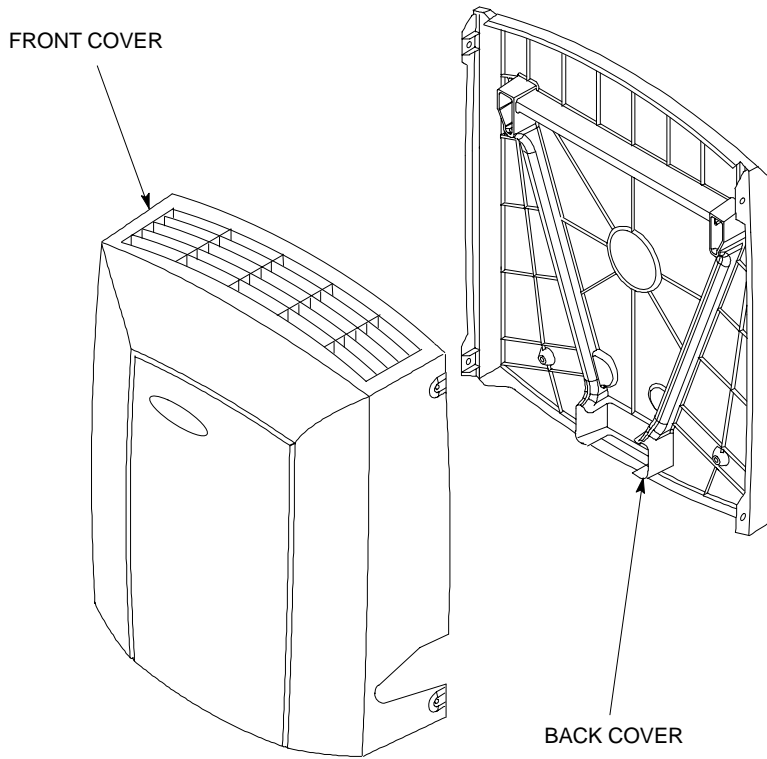
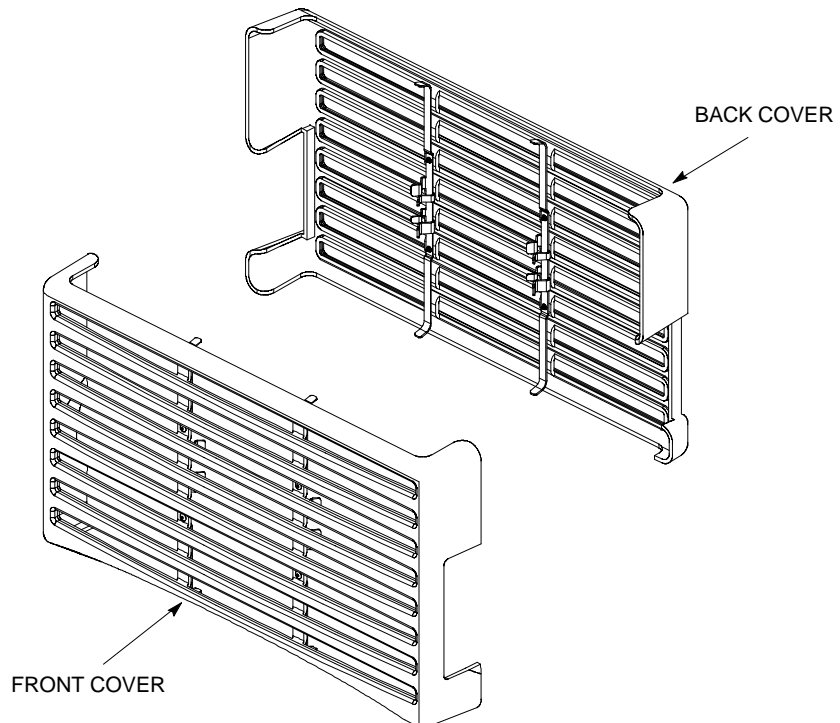

Figure 8-3: Front and Back Fin Covers



# Shut Down & Restoring BTS Signaling

## Objective

The FRU procedures require the shut down of BTS signalling functions.

## Accessing the OMCR CLI window

The commands to manipulate the BTS in the following replacement procedure must be entered via UNO or OMCR (Operations and Maintenance Center – Radio).



### IMPORTANT

Should there be any issues which affect CLI operations or the UNO/OMCR, this replacement procedure cannot be performed.

## Accessing the OMCR CLI window

The commands used in the following replacement procedure in Table 8-1 are entered at the OMCR.

Table 8-1: Procedure to Login and Access Alarm Window	
Step	Action
1	Login by entering the user name.
2	Enter the password at the system prompt.
3	Open an Alarm Manager window and an OMCR CLI window from the pull down menu using the mouse button.
4	Verify that the filter display is set to ALL. This is so that any alarms which may be encountered while installing the hardware can be observed and rectified.

## Shut Down Signaling Functions

Table 8-2 contains steps for shutting down the signaling functions for the sector/site.

### NOTE

The BTS acts like a single sector and all sector commands operate on the BTS carrier.



**IMPORTANT**

The **EDIT SECTOR REDIRECT** or **REDIRECT2** command does NOT affect calls in progress and will NOT move these calls to another sector/carrier. The command only prevents future calls from being originated on the targeted sector/carrier. If active call processing is still taking place in the target sector/carrier, it is advisable to wait for any active calls to terminate prior to disabling the sector.

**Table 8-2: Procedure to Shut Down Signaling Functions**

Step	Action
1	Open a CLI window. Refer to Table 8-1.
2	<p><b>* IMPORTANT</b></p> <p>Record the values shown in the following system display response. These values will be used to answer the prompts for the <b>EDIT SECTOR REDIRECT</b> command when restoring signaling operations at the end of the replacement procedure.</p> <p>View the status of the sector signaling redirect parameters for all carriers equipped for the sector by entering the following command at the prompt:</p> <p>omc-000000&gt;<b>display sector--&lt;bts#&gt;--&lt;sector#&gt; redirect</b></p> <p>Observe the following <i>typical</i> system display response (this example shows initial standard values):</p> <pre> CARRIER ID          RETURN      Access Overload Class Redirect Flags  ROTATE (bts-sector-carrier) IF FAIL    0 0 0 0 0 0 0 0 0 1 1 1 1 1 1 1  TIMER -----            ----- CARRIER-1-1-1      N          N N N N N N N N N N N N N N N N   4    1    0    N    CUSTOM                     </pre>

... continued on next page



**Table 8-2: Procedure to Shut Down Signaling Functions**

Step	Action
3	<p><b>NOTE</b></p> <p>This step edits the redirect parameters so that the Global Service Redirect Message broadcast on the paging channel redirects all subscribers away from the sector with the failed equipment and onto a different system.</p> <p>Enter the following command at the prompt:</p> <pre>omc-000000&gt;edit sector-&lt;bts#&gt;-&lt;sector#&gt; redirect !</pre> <p>The system will prompt you to enter each command parameter value one at a time. Answer the prompts in the following order:</p> <pre>&lt;accolc0&gt; enter Y, &lt;accolc1&gt; enter Y, ... &lt;accolc15&gt; enter Y</pre> <p>All Access Overload Classes <i>must</i> be set to <b>Y</b> (yes) to ensure that all subscribers are redirected.</p> <pre>&lt;returniffail&gt; , enter N</pre> <p>Must be set to no to ensure that subscribers do not return if redirect is unsuccessful.</p> <pre>&lt;recordtype&gt; , enter 1 or 2</pre> <p>A value of 2 will invoke <b>REDIRECT2</b> which is used to redirect subscribers to a CDMA channel at a neighbor site. A value of 1 redirects subscribers to an 800 MHz analog site. This example uses 2.</p> <pre>&lt;expectedsid&gt; , enter 13</pre> <p>Use the Area ID the subscriber units should expect to find on the system they are being redirected to. This example uses 13.</p> <pre>&lt;ignorecdma&gt; , enter Y</pre> <pre>&lt;sysordering&gt; , enter custom</pre> <p>The system acquisition ordering value tells the mobiles the order to use when attempting to obtain service on the different analog systems. The valid values are: <b>custom</b> – use custom system selection (default selection); <b>aonly</b> – try the A system only; <b>bonly</b> – use the B system only; <b>afirst</b> – try the A system first. If unsuccessful, enter <b>bfirst</b> to try the B system first. If unsuccessful, enter <b>aorb</b> to try the A or B. If unsuccessful, enter <b>custom</b> to try the alternative system.</p> <pre>&lt;rotatetimer&gt; , enter 4</pre> <p>Call processing continuously rotates, circular right–shifts, the Y/N values of Access Overload Class Redirect Flags 0 to 9. Values are shifted one flag at the end of the timer period; then timer re–starts. Valid values are 0–255; 4 is default.</p> <p>The system will display the command that will be sent. Verify the command syntax.</p> <pre>omc-000000&gt;Accept [yes/no]?</pre> <p>Enter <b>Y</b> to accept the command.</p>
. . . continued on next page	

**Table 8-2: Procedure to Shut Down Signaling Functions**

Step	Action
4	<p>View the status of the sector signaling redirect parameters to verify that the sector is ready for maintenance.</p> <p>omc-000000&gt;<b>display sector</b>--&lt;bts#&gt;--&lt;sector#&gt; <b>redirect</b></p> <p>Ensure that the values in the system display response match the values input in step 3 (see example below).</p> <pre> Access Overload Class Redirect Flags   ROTATE CARRIER ID      RETURN   0 0 0 0 0 0 0 0 0 1 1 1 1 1 1   TIMER (btsc-sector-carrier)  IF FAIL  0 1 2 3 4 5 6 7 8 9 0 1 2 3 4 5   (SEC) ----- CARRIER-1-1-1      N      Y Y Y Y Y Y Y Y Y Y Y Y Y Y Y   4      4      13     Y     CUSTOM     </pre>
5	<p>If you entered <b>2</b> for &lt;recordtype&gt; in step 3, go to step 6.</p> <p>If you entered <b>1</b> for &lt;recordtype&gt; in step 3, go to step 9.</p>
6	<p><b>* IMPORTANT</b></p> <p>Record the values shown in the following system display response. These values will be used to answer the prompts for the <b>EDIT SECTOR REDIRECT2</b> command when restoring signaling operations at the end of the replacement procedure.</p> <p>View the status of the BTS signaling redirect parameters for all carriers equipped for the BTS. Enter the following command at the prompt:</p> <p>omc-000000&gt;<b>display sector</b>--&lt;bts#&gt;--&lt;sector#&gt; <b>redirect2</b></p> <p>Ensure that the values in the system display response match the values input in step 3.</p> <p>Observe the following typical system output:</p> <pre> Access Overload Class Redirect Flags CARRIER ID      EXP   BAND  1  2  3  4  5  6  7  8  9  10 11 12 13 14 15 (btsc-sector-carrier)  NID  CLASS ----- CARRIER-1-1-1      65535  AMPS  -  -  -  -  -  -  -  -  -  -  -  -  -  -     </pre>
<p>... continued on next page</p>	

## Shut Down & Restore BTS Signaling – continued

**Table 8-2: Procedure to Shut Down Signaling Functions**

Step	Action																				
7	<p><b>NOTE</b></p> <p>This step edits the <b>REDIRECT2</b> parameters so that the Global Service Redirect Message broadcast on the paging channel redirects all subscribers away from the BTS with the failed equipment and onto a CDMA channel at a neighbor site.</p> <p>Enter the following command at the prompt:</p> <pre>omc-000000&gt; <b>edit sector</b> -&lt;bts#&gt; <b>redirect2!</b></pre> <p>The system prompts you to enter each command parameter value one at a time. Answer the prompts in the following order:</p> <p>expecting an integer number (from 0 to 65535) &lt;EXPID=?&gt;</p> <p>Use the Network ID the subscriber units should expect to find on the system they are being redirected to. This example uses 555.</p> <p>expecting an integer number (from 0 to 2047) &lt;CHAN1=?&gt;, &lt;CHAN2=?&gt;...&lt;CHAN15=?&gt;</p> <p>A list of CDMA channels for neighbor sites that the subscriber units can use for redirection. This example uses 200, 350, 400, 725, 75, 175, 100, 575, and 950.</p> <p>expecting an enumerated value: CDMA1900 CDMA800 CDMA900 JAPANCDMA &lt;BANDCLASS=?&gt;</p> <p>Use CDMA1900 for 1.9 GHz systems and CDMA800 for 800 MHz systems. This example uses CDMA1900.</p> <p>The system displays the command to be sent. Verify the command syntax.</p> <pre>omc-000000&gt;Accept [yes/no]?</pre> <p>Enter <b>Y</b> to accept the command or <b>N</b> to go back and enter the correct value(s).</p>																				
8	<p>View the status of the BTS signalling <b>REDIRECT2</b> parameters to verify that the BTS is ready for maintenance.</p> <pre>omc-000000&gt; <b>display sector</b> -&lt;bts#&gt; <b>redirect2</b></pre> <p>Make sure that the values in the system display response match the values input in step 7 (see example below):</p> <table border="1" data-bbox="300 1465 1429 1556"> <thead> <tr> <th>CARRIER ID (bts-sector-carrier)</th> <th>RETURN IF FAIL</th> <th>Access Overload Class</th> <th>Redirect</th> <th>Flags</th> <th>ROTATE TIMER (SEC)</th> <th>RECORD TYPE</th> <th>EXP SID</th> <th>IGNORE CDMA</th> <th>SYS ORDERING</th> </tr> </thead> <tbody> <tr> <td>CARRIER-1-1-1</td> <td>N</td> <td>Y Y Y Y Y Y Y Y</td> <td>Y Y Y Y Y Y Y Y</td> <td>Y Y Y Y Y Y Y Y</td> <td>4</td> <td>4</td> <td>13</td> <td>Y</td> <td>CUSTOM</td> </tr> </tbody> </table>	CARRIER ID (bts-sector-carrier)	RETURN IF FAIL	Access Overload Class	Redirect	Flags	ROTATE TIMER (SEC)	RECORD TYPE	EXP SID	IGNORE CDMA	SYS ORDERING	CARRIER-1-1-1	N	Y Y Y Y Y Y Y Y	Y Y Y Y Y Y Y Y	Y Y Y Y Y Y Y Y	4	4	13	Y	CUSTOM
CARRIER ID (bts-sector-carrier)	RETURN IF FAIL	Access Overload Class	Redirect	Flags	ROTATE TIMER (SEC)	RECORD TYPE	EXP SID	IGNORE CDMA	SYS ORDERING												
CARRIER-1-1-1	N	Y Y Y Y Y Y Y Y	Y Y Y Y Y Y Y Y	Y Y Y Y Y Y Y Y	4	4	13	Y	CUSTOM												

... continued on next page

**Table 8-2: Procedure to Shut Down Signaling Functions**

Step	Action																																																	
9	<p>View the existing congestion control parameters for all carriers equipped for the sector by entering the following command at the prompt:</p> <pre>omc-000000&gt;display sector--&lt;bts#&gt;--&lt;sector#&gt; congestconf</pre> <p>Observe the following <i>typical</i> system display response:</p> <table border="1" data-bbox="300 583 1442 667"> <thead> <tr> <th>CARRIER (bts#-sector#-carrier#)</th> <th>SET</th> <th>NEWCALL ALARMFLAG</th> <th>REG ALARMFLAG</th> <th>AGG ALARMFLAG</th> <th>ANALOGREDIRECT</th> <th>GLOBALREDIRECT</th> </tr> </thead> <tbody> <tr> <td>300-1-4</td> <td>1</td> <td>ENABLE</td> <td>ENABLE</td> <td>ENABLE</td> <td>DISABLE</td> <td>DISABLE</td> </tr> </tbody> </table>	CARRIER (bts#-sector#-carrier#)	SET	NEWCALL ALARMFLAG	REG ALARMFLAG	AGG ALARMFLAG	ANALOGREDIRECT	GLOBALREDIRECT	300-1-4	1	ENABLE	ENABLE	ENABLE	DISABLE	DISABLE																																			
CARRIER (bts#-sector#-carrier#)	SET	NEWCALL ALARMFLAG	REG ALARMFLAG	AGG ALARMFLAG	ANALOGREDIRECT	GLOBALREDIRECT																																												
300-1-4	1	ENABLE	ENABLE	ENABLE	DISABLE	DISABLE																																												
10	<p><b>NOTE</b></p> <p>In this step, you will change the value of the Global Service Redirection Flag (GLOBALREDIRECT) in the congestion control parameters so that the Global Service Redirect Message is broadcast on the sector paging channel.</p> <p>Enter the following command at the prompt:</p> <pre>omc-000000&gt;edit sector--&lt;bts#&gt;--&lt;sector#&gt; congestconf !</pre> <p>The system will prompt you to enter each control parameter value one at a time. Skip through the prompts until you get to the following:</p> <pre>&lt;globalredirect&gt; , enter enable</pre> <p>(This will force the Global Service Redirect Message to be broadcast on the sector paging channel.)</p> <p>The system will display the values of the control parameters. Verify that only the <code>globalredirect</code> value changed.</p> <pre>omc-000000&gt;Accept [yes/no]?</pre> <p>Enter <b>Y</b> to accept the change.</p> <p>Now the Global Service Redirection Message is sent over the sector paging channels. All subscribers are redirected away from the sector and onto a different system. This effectively shuts down the sector.</p>																																																	
11	<p>Display the status of the MAWI at the BTS by entering the following command at the prompt:</p> <pre>omc-000000&gt;display bts--&lt;bts#&gt; status</pre> <p>Observe the following <i>typical</i> system response for the entry of: <b>DISPLAY BTS – 300 STATUS</b></p> <table border="1" data-bbox="300 1591 1442 1829"> <thead> <tr> <th>DEVICE</th> <th>CBSC</th> <th>STATUS</th> <th>Config Data</th> <th>DEVSYNC Calibration Data</th> <th>Calibration Sync</th> <th>ISO RELATED STATE</th> </tr> </thead> <tbody> <tr> <td>BTS-300</td> <td>1</td> <td>INS</td> <td>n/a</td> <td>n/a</td> <td>UNLOCKED</td> <td>UNLOCKED</td> </tr> <tr> <td>BTSSPAN-300-1</td> <td>1</td> <td>INS</td> <td>n/a</td> <td>n/a</td> <td>n/a</td> <td>n/a</td> </tr> <tr> <td>BTSLINK-300-1</td> <td>1</td> <td>INS</td> <td>n/a</td> <td>n/a</td> <td>n/a</td> <td>n/a</td> </tr> <tr> <td>LPA-300-1</td> <td>1</td> <td>OOS_PARENT</td> <td>n/a</td> <td>n/a</td> <td>n/a</td> <td>n/a</td> </tr> <tr> <td>MDM-300-1</td> <td>1</td> <td>PRECUT</td> <td>n/a</td> <td>n/a</td> <td>n/a</td> <td>n/a</td> </tr> <tr> <td>MAWI-300-1</td> <td>1</td> <td>INS</td> <td>GOOD</td> <td>GOOD</td> <td>GOOD</td> <td>KEYED</td> </tr> </tbody> </table>	DEVICE	CBSC	STATUS	Config Data	DEVSYNC Calibration Data	Calibration Sync	ISO RELATED STATE	BTS-300	1	INS	n/a	n/a	UNLOCKED	UNLOCKED	BTSSPAN-300-1	1	INS	n/a	n/a	n/a	n/a	BTSLINK-300-1	1	INS	n/a	n/a	n/a	n/a	LPA-300-1	1	OOS_PARENT	n/a	n/a	n/a	n/a	MDM-300-1	1	PRECUT	n/a	n/a	n/a	n/a	MAWI-300-1	1	INS	GOOD	GOOD	GOOD	KEYED
DEVICE	CBSC	STATUS	Config Data	DEVSYNC Calibration Data	Calibration Sync	ISO RELATED STATE																																												
BTS-300	1	INS	n/a	n/a	UNLOCKED	UNLOCKED																																												
BTSSPAN-300-1	1	INS	n/a	n/a	n/a	n/a																																												
BTSLINK-300-1	1	INS	n/a	n/a	n/a	n/a																																												
LPA-300-1	1	OOS_PARENT	n/a	n/a	n/a	n/a																																												
MDM-300-1	1	PRECUT	n/a	n/a	n/a	n/a																																												
MAWI-300-1	1	INS	GOOD	GOOD	GOOD	KEYED																																												

... continued on next page

## Shut Down & Restore BTS Signaling – continued

**Table 8-2: Procedure to Shut Down Signaling Functions**

Step	Action																																																																																																																																																
12	<p>Display the status of the MAWI at the BTS to verify the status of the MAWI (which CEs are INS_IDLE or INS_BUSY) by entering the following command at the prompt:</p> <pre>omc-000000&gt;status mawi-&lt;bts#&gt;-&lt;mawi#&gt; add</pre> <p>Observe the following <i>typical</i> system response:</p> <pre>MAWI-300-1 00-05-24 15:10:31 omcr5 MM-5 M000109.00046 045519/479457 INFO:42 "Mawi Status Response" TELSTATE=INS_ACTIVE PROCEDURE=NONE PHYSTATE=INS_ACTIVE HDWR_TYPE=MAWI DEVICE_ASSUMED=NONE CLOCK_SRC=REMOTE_GPS LATITUDE="+032:50:41.502" LONGITUDE="-097:17:38.645" ALTITUDE="+0019865" NUM_SATELLITES="8"</pre> <table border="1" data-bbox="381 751 1421 1297"> <thead> <tr> <th>CF</th> <th>MMCONF</th> <th>MMSTATE</th> <th>MMSECTOR</th> <th>PHYCONF</th> <th>PHYSTATE</th> <th>PHYREASON</th> <th>PHYSECTOR</th> </tr> </thead> <tbody> <tr><td>--</td><td>-----</td><td>-----</td><td>-----</td><td>-----</td><td>-----</td><td>-----</td><td>-----</td></tr> <tr><td>0</td><td>PCH_ACH</td><td>INS_BUSY</td><td>1</td><td>PCH_ACH</td><td>INS_BUSY</td><td>NONE</td><td>1</td></tr> <tr><td>1</td><td>SCH</td><td>INS_BUSY</td><td>1</td><td>SCH</td><td>INS_BUSY</td><td>NONE</td><td>1</td></tr> <tr><td>2</td><td>TCH</td><td>INS_IDLE</td><td>FLOAT</td><td>TCH</td><td>INS_IDLE</td><td>NONE</td><td>FLOAT</td></tr> <tr><td>3</td><td>TCH</td><td>INS_IDLE</td><td>FLOAT</td><td>TCH</td><td>INS_IDLE</td><td>NONE</td><td>FLOAT</td></tr> <tr><td>4</td><td>TCH</td><td>INS_IDLE</td><td>FLOAT</td><td>TCH</td><td>INS_IDLE</td><td>NONE</td><td>FLOAT</td></tr> <tr><td>5</td><td>TCH</td><td>INS_IDLE</td><td>FLOAT</td><td>TCH</td><td>INS_IDLE</td><td>NONE</td><td>FLOAT</td></tr> <tr><td>6</td><td>TCH</td><td>INS_IDLE</td><td>FLOAT</td><td>TCH</td><td>INS_IDLE</td><td>NONE</td><td>FLOAT</td></tr> <tr><td>7</td><td>TCH</td><td>INS_IDLE</td><td>FLOAT</td><td>TCH</td><td>INS_IDLE</td><td>NONE</td><td>FLOAT</td></tr> <tr><td>8</td><td>TCH</td><td>INS_IDLE</td><td>FLOAT</td><td>TCH</td><td>INS_IDLE</td><td>NONE</td><td>FLOAT</td></tr> <tr><td>9</td><td>TCH</td><td>INS_IDLE</td><td>FLOAT</td><td>TCH</td><td>INS_IDLE</td><td>NONE</td><td>FLOAT</td></tr> <tr><td>10</td><td>TCH</td><td>INS_IDLE</td><td>FLOAT</td><td>TCH</td><td>INS_IDLE</td><td>NONE</td><td>FLOAT</td></tr> <tr><td>11</td><td>TCH</td><td>INS_IDLE</td><td>FLOAT</td><td>TCH</td><td>INS_IDLE</td><td>NONE</td><td>FLOAT</td></tr> <tr><td>12</td><td>TCH</td><td>INS_IDLE</td><td>FLOAT</td><td>TCH</td><td>INS_IDLE</td><td>NONE</td><td>FLOAT</td></tr> <tr><td>13</td><td>TCH</td><td>INS_IDLE</td><td>FLOAT</td><td>TCH</td><td>INS_IDLE</td><td>NONE</td><td>FLOAT</td></tr> <tr><td>14</td><td>TCH</td><td>INS_IDLE</td><td>FLOAT</td><td>TCH</td><td>INS_IDLE</td><td>NONE</td><td>FLOAT</td></tr> <tr><td>15</td><td>TCH</td><td>INS_IDLE</td><td>FLOAT</td><td>TCH</td><td>INS_IDLE</td><td>NONE</td><td>FLOAT</td></tr> </tbody> </table>	CF	MMCONF	MMSTATE	MMSECTOR	PHYCONF	PHYSTATE	PHYREASON	PHYSECTOR	--	-----	-----	-----	-----	-----	-----	-----	0	PCH_ACH	INS_BUSY	1	PCH_ACH	INS_BUSY	NONE	1	1	SCH	INS_BUSY	1	SCH	INS_BUSY	NONE	1	2	TCH	INS_IDLE	FLOAT	TCH	INS_IDLE	NONE	FLOAT	3	TCH	INS_IDLE	FLOAT	TCH	INS_IDLE	NONE	FLOAT	4	TCH	INS_IDLE	FLOAT	TCH	INS_IDLE	NONE	FLOAT	5	TCH	INS_IDLE	FLOAT	TCH	INS_IDLE	NONE	FLOAT	6	TCH	INS_IDLE	FLOAT	TCH	INS_IDLE	NONE	FLOAT	7	TCH	INS_IDLE	FLOAT	TCH	INS_IDLE	NONE	FLOAT	8	TCH	INS_IDLE	FLOAT	TCH	INS_IDLE	NONE	FLOAT	9	TCH	INS_IDLE	FLOAT	TCH	INS_IDLE	NONE	FLOAT	10	TCH	INS_IDLE	FLOAT	TCH	INS_IDLE	NONE	FLOAT	11	TCH	INS_IDLE	FLOAT	TCH	INS_IDLE	NONE	FLOAT	12	TCH	INS_IDLE	FLOAT	TCH	INS_IDLE	NONE	FLOAT	13	TCH	INS_IDLE	FLOAT	TCH	INS_IDLE	NONE	FLOAT	14	TCH	INS_IDLE	FLOAT	TCH	INS_IDLE	NONE	FLOAT	15	TCH	INS_IDLE	FLOAT	TCH	INS_IDLE	NONE	FLOAT
CF	MMCONF	MMSTATE	MMSECTOR	PHYCONF	PHYSTATE	PHYREASON	PHYSECTOR																																																																																																																																										
--	-----	-----	-----	-----	-----	-----	-----																																																																																																																																										
0	PCH_ACH	INS_BUSY	1	PCH_ACH	INS_BUSY	NONE	1																																																																																																																																										
1	SCH	INS_BUSY	1	SCH	INS_BUSY	NONE	1																																																																																																																																										
2	TCH	INS_IDLE	FLOAT	TCH	INS_IDLE	NONE	FLOAT																																																																																																																																										
3	TCH	INS_IDLE	FLOAT	TCH	INS_IDLE	NONE	FLOAT																																																																																																																																										
4	TCH	INS_IDLE	FLOAT	TCH	INS_IDLE	NONE	FLOAT																																																																																																																																										
5	TCH	INS_IDLE	FLOAT	TCH	INS_IDLE	NONE	FLOAT																																																																																																																																										
6	TCH	INS_IDLE	FLOAT	TCH	INS_IDLE	NONE	FLOAT																																																																																																																																										
7	TCH	INS_IDLE	FLOAT	TCH	INS_IDLE	NONE	FLOAT																																																																																																																																										
8	TCH	INS_IDLE	FLOAT	TCH	INS_IDLE	NONE	FLOAT																																																																																																																																										
9	TCH	INS_IDLE	FLOAT	TCH	INS_IDLE	NONE	FLOAT																																																																																																																																										
10	TCH	INS_IDLE	FLOAT	TCH	INS_IDLE	NONE	FLOAT																																																																																																																																										
11	TCH	INS_IDLE	FLOAT	TCH	INS_IDLE	NONE	FLOAT																																																																																																																																										
12	TCH	INS_IDLE	FLOAT	TCH	INS_IDLE	NONE	FLOAT																																																																																																																																										
13	TCH	INS_IDLE	FLOAT	TCH	INS_IDLE	NONE	FLOAT																																																																																																																																										
14	TCH	INS_IDLE	FLOAT	TCH	INS_IDLE	NONE	FLOAT																																																																																																																																										
15	TCH	INS_IDLE	FLOAT	TCH	INS_IDLE	NONE	FLOAT																																																																																																																																										
13	<p>Disable the MAWI in the INS_IDLE or the INS_BUSY state (predetermine number of active calls remaining to be terminated prematurely) by entering the following command at the prompt:</p> <pre>omc-000000&gt;disable mawi-&lt;bts#&gt;-&lt;mawi#&gt; unc</pre>																																																																																																																																																
14	<p>Disable the BTS where the replacement procedure will be performed by entering the following command at the prompt:</p> <pre>omc-000000&gt;disable bts-&lt;bts#&gt; unc</pre>																																																																																																																																																

# Shut Down & Restore BTS Signaling – continued

## Restore Signaling Operations

Follow the steps in Table 8-3 to restore signaling operations to the site.

Table 8-3: Procedure to Restore Signaling Operations																	
Step	Action																
1	Open a CLI window. Refer to Table 8-1.																
2	Enable the BTS by entering the following command at the prompt: omc-000000> <b>enable bts</b> –<bts#> <b>unc</b>																
3	Enable the MAWI by entering the following command at the prompt: omc-000000> <b>enable mawi</b> –<bts#> <b>unc</b>																
4	View the status of the sector signaling redirect parameters for all carriers equipped for the sector by entering the following command at the prompt: omc-000000> <b>display sector</b> –<bts#>–<sector#> <b>redirect</b>  Observe that the values in the system display response should match the values input in step 3 of the shut down signaling functions table.  <table border="1"> <thead> <tr> <th>CARRIER ID (bts-sector-carrier)</th> <th>RETURN IF FAIL</th> <th>Access Overload Class Redirect Flags</th> <th>ROTATE TIMER (SEC)</th> <th>RECORD TYPE</th> <th>EXP SID</th> <th>IGNORE CDMA</th> <th>SYS ORDERING</th> </tr> </thead> <tbody> <tr> <td>CARRIER-1-1-1</td> <td>N</td> <td>0 0 0 0 0 0 0 0 0 1 1 1 1 1 1</td> <td>4</td> <td>4</td> <td>13</td> <td>Y</td> <td>CUSTOM</td> </tr> </tbody> </table>	CARRIER ID (bts-sector-carrier)	RETURN IF FAIL	Access Overload Class Redirect Flags	ROTATE TIMER (SEC)	RECORD TYPE	EXP SID	IGNORE CDMA	SYS ORDERING	CARRIER-1-1-1	N	0 0 0 0 0 0 0 0 0 1 1 1 1 1 1	4	4	13	Y	CUSTOM
CARRIER ID (bts-sector-carrier)	RETURN IF FAIL	Access Overload Class Redirect Flags	ROTATE TIMER (SEC)	RECORD TYPE	EXP SID	IGNORE CDMA	SYS ORDERING										
CARRIER-1-1-1	N	0 0 0 0 0 0 0 0 0 1 1 1 1 1 1	4	4	13	Y	CUSTOM										
. . . continued on next page																	

## Shut Down & Restore BTS Signaling – continued

Table 8-3: Procedure to Restore Signaling Operations																																					
Step	Action																																				
5	<p><b>* IMPORTANT</b></p> <p>In this step, use the values recorded in step 2 of the shut down signaling functions table to answer the prompts for the EDIT SECTOR REDIRECT command; except for record type enter 2.</p> <p><b>NOTE</b></p> <p>This step shows the entry of initial standard values which is consistent with the original example; except record type must be 2. Your entries may be different.</p> <p>Restore the values of all redirect parameters by entering the following command at the prompt:</p> <pre>omc-000000&gt;edit sector--&lt;bts#&gt;--&lt;sector#&gt; redirect !</pre> <p>The system will prompt you to enter each command parameter one at a time. Answer the prompts in the following order (Note that the following specified values are consistent with the original example. Yours may be different):</p> <pre>&lt;accolc0&gt; Enter N, &lt;accolc1&gt; Enter N, ... &lt;accolc15&gt; enter N &lt;returniffail&gt; , enter N &lt;recordtype&gt; , enter 2 &lt;expectedsid&gt; , enter 0 &lt;ignorecdma&gt; , enter N &lt;sysordering&gt; , enter custom &lt;rotatetimer&gt; , enter 4</pre> <p>The system will display the command that will be sent. Verify the command syntax.</p> <pre>omc-000000&gt;Accept [yes/no]?</pre> <p>Enter Y to accept the command.</p>																																				
6	<p>View the status of the sector signaling redirect parameters to verify that the sector is ready for maintenance.</p> <pre>omc-000000&gt;display sector--&lt;bts#&gt;--&lt;sector#&gt; redirect</pre> <p>Ensure that the values in the system display response match the values input by the operator in step 5 (see example below).</p> <table border="1" style="width: 100%; border-collapse: collapse;"> <thead> <tr> <th>CARRIER ID (bts-sector-carrier)</th> <th>RETURN IF FAIL</th> <th>Access</th> <th>Overload</th> <th>Class</th> <th>Redirect</th> <th>Flags</th> <th>ROTATE TIMER (SEC)</th> <th>RECORD TYPE</th> <th>EXP SID</th> <th>IGNORE CDMA</th> <th>SYS ORDERING</th> </tr> <tr> <th>-----</th> <th>-----</th> <th>-----</th> <th>-----</th> <th>-----</th> <th>-----</th> <th>-----</th> <th>-----</th> <th>-----</th> <th>-----</th> <th>-----</th> <th>-----</th> </tr> </thead> <tbody> <tr> <td>CARRIER-1-1-1</td> <td>N</td> <td>N</td> <td>N</td> <td>N</td> <td>N</td> <td>N</td> <td>4</td> <td>2</td> <td>0</td> <td>N</td> <td>CUSTOM</td> </tr> </tbody> </table>	CARRIER ID (bts-sector-carrier)	RETURN IF FAIL	Access	Overload	Class	Redirect	Flags	ROTATE TIMER (SEC)	RECORD TYPE	EXP SID	IGNORE CDMA	SYS ORDERING	-----	-----	-----	-----	-----	-----	-----	-----	-----	-----	-----	-----	CARRIER-1-1-1	N	N	N	N	N	N	4	2	0	N	CUSTOM
CARRIER ID (bts-sector-carrier)	RETURN IF FAIL	Access	Overload	Class	Redirect	Flags	ROTATE TIMER (SEC)	RECORD TYPE	EXP SID	IGNORE CDMA	SYS ORDERING																										
-----	-----	-----	-----	-----	-----	-----	-----	-----	-----	-----	-----																										
CARRIER-1-1-1	N	N	N	N	N	N	4	2	0	N	CUSTOM																										

... continued on next page

## Shut Down & Restore BTS Signaling – continued

**Table 8-3: Procedure to Restore Signaling Operations**

Step	Action																																																	
7	<p>View the congestion control parameters for all carriers equipped for the sector by entering the following command at the prompt:</p> <pre>omc-000000&gt;display sector--&lt;bts#&gt;--&lt;sector#&gt; congestconf</pre> <p>Observe the following <i>typical</i> system display response:</p> <table border="1" data-bbox="300 556 1453 640"> <thead> <tr> <th>CARRIER (bts#-sector#-carrier#)</th> <th>SET</th> <th>NEWCALL ALARMFLAG</th> <th>REG ALARMFLAG</th> <th>AGG ALARMFLAG</th> <th>ANALOGREDIRECT</th> <th>GLOBALREDIRECT</th> </tr> </thead> <tbody> <tr> <td>300-1-4</td> <td>1</td> <td>ENABLE</td> <td>ENABLE</td> <td>ENABLE</td> <td>DISABLE</td> <td>ENABLE</td> </tr> </tbody> </table>	CARRIER (bts#-sector#-carrier#)	SET	NEWCALL ALARMFLAG	REG ALARMFLAG	AGG ALARMFLAG	ANALOGREDIRECT	GLOBALREDIRECT	300-1-4	1	ENABLE	ENABLE	ENABLE	DISABLE	ENABLE																																			
CARRIER (bts#-sector#-carrier#)	SET	NEWCALL ALARMFLAG	REG ALARMFLAG	AGG ALARMFLAG	ANALOGREDIRECT	GLOBALREDIRECT																																												
300-1-4	1	ENABLE	ENABLE	ENABLE	DISABLE	ENABLE																																												
8	<p><b>NOTE</b></p> <p>In this step, you will change the value of the Global Service Redirection Flag (GLOBALREDIRECT) in the congestion control parameters so that the Global Service Redirect Message is only broadcast on the sector paging channel when there is traffic congestion in the sector.</p> <p>Enter the following command at the prompt:</p> <pre>omc-000000&gt;edit sector--&lt;bts#&gt;--&lt;sector#&gt; congestconf !</pre> <p>The system will prompt you to enter each control parameter value one at a time. Skip through the prompts until you get to the following:</p> <pre>&lt;globalredirect&gt; , enter <b>disable</b></pre> <p>(This will revert the Global Service Redirect Message to congestion control.)</p> <p>The system will display the values of the control parameters. Verify that only the GLOBALREDIRECT value changed.</p> <pre>omc-000000&gt;Accept [yes/no]?</pre> <p>Enter <b>Y</b> to accept the change.</p> <p>Now the Global Service Redirection Message will only be sent over the sector paging channels when there is traffic congestion in the sector.</p>																																																	
9	<p>Display the status of the MAWI at the BTS by entering the following command at the prompt:</p> <pre>omc-000000&gt;display bts--&lt;bts#&gt; status</pre> <p>Observe the following <i>typical</i> system response:</p> <table border="1" data-bbox="300 1533 1453 1774"> <thead> <tr> <th>DEVICE</th> <th>CBSC</th> <th>STATUS</th> <th>Config Data</th> <th>DEVSYNC Calibration Data</th> <th>Calibration Sync</th> <th>ISO RELATED STATE</th> </tr> </thead> <tbody> <tr> <td>BTS-300</td> <td>1</td> <td>INS</td> <td>n/a</td> <td>n/a</td> <td>UNLOCKED</td> <td>UNLOCKED</td> </tr> <tr> <td>BTSSPAN-300-1</td> <td>1</td> <td>INS</td> <td>n/a</td> <td>n/a</td> <td>n/a</td> <td>n/a</td> </tr> <tr> <td>BTSLINK-300-1</td> <td>1</td> <td>INS</td> <td>n/a</td> <td>n/a</td> <td>n/a</td> <td>n/a</td> </tr> <tr> <td>LPA-300-1</td> <td>1</td> <td>OOS_PARENT</td> <td>n/a</td> <td>n/a</td> <td>n/a</td> <td>n/a</td> </tr> <tr> <td>MDM-300-1</td> <td>1</td> <td>PRECUT</td> <td>n/a</td> <td>n/a</td> <td>n/a</td> <td>n/a</td> </tr> <tr> <td>MAWI-300-1</td> <td>1</td> <td>INS</td> <td>GOOD</td> <td>GOOD</td> <td>GOOD</td> <td>KEYED</td> </tr> </tbody> </table>	DEVICE	CBSC	STATUS	Config Data	DEVSYNC Calibration Data	Calibration Sync	ISO RELATED STATE	BTS-300	1	INS	n/a	n/a	UNLOCKED	UNLOCKED	BTSSPAN-300-1	1	INS	n/a	n/a	n/a	n/a	BTSLINK-300-1	1	INS	n/a	n/a	n/a	n/a	LPA-300-1	1	OOS_PARENT	n/a	n/a	n/a	n/a	MDM-300-1	1	PRECUT	n/a	n/a	n/a	n/a	MAWI-300-1	1	INS	GOOD	GOOD	GOOD	KEYED
DEVICE	CBSC	STATUS	Config Data	DEVSYNC Calibration Data	Calibration Sync	ISO RELATED STATE																																												
BTS-300	1	INS	n/a	n/a	UNLOCKED	UNLOCKED																																												
BTSSPAN-300-1	1	INS	n/a	n/a	n/a	n/a																																												
BTSLINK-300-1	1	INS	n/a	n/a	n/a	n/a																																												
LPA-300-1	1	OOS_PARENT	n/a	n/a	n/a	n/a																																												
MDM-300-1	1	PRECUT	n/a	n/a	n/a	n/a																																												
MAWI-300-1	1	INS	GOOD	GOOD	GOOD	KEYED																																												

... continued on next page



## Shut Down & Restore BTS Signaling – continued

**Table 8-3: Procedure to Restore Signaling Operations**

Step	Action																																																																																																																																																
10	<p>Display the status of the MAWI in the BTS by entering the following command at the prompt:</p> <pre>omc-000000&gt;status mawi-&lt;bts#&gt;-&lt;mawi#&gt; add</pre> <p>Observe the following <i>typical</i> system response for entry of: <b>STATUS MAWI – 300 –1 ADD</b></p> <pre>MAWI-300-1 00-05-24 15:10:31 omcr5 MM-5 M000109.00046 045519/479457 INFO:42 "Mawi Status Response" TELSTATE=INS_ACTIVE PROCEDURE=NONE PHYSTATE=INS_ACTIVE HDWR_TYPE=MAWI DEVICE_ASSUMED=NONE CLOCK_SRC=REMOTE_GPS LATITUDE="+032:50:41.502" LONGITUDE="-097:17:38.645" ALTITUDE="+0019865" NUM_SATELLITES="8"</pre> <table border="1" data-bbox="381 724 1421 1270"> <thead> <tr> <th>CF</th> <th>MMCONF</th> <th>MMSTATE</th> <th>MMSECTOR</th> <th>PHYCONF</th> <th>PHYSTATE</th> <th>PHYREASON</th> <th>PHYSECTOR</th> </tr> </thead> <tbody> <tr><td>--</td><td>-----</td><td>-----</td><td>-----</td><td>-----</td><td>-----</td><td>-----</td><td>-----</td></tr> <tr><td>0</td><td>PCH_ACH</td><td>INS_BUSY</td><td>1</td><td>PCH_ACH</td><td>INS_BUSY</td><td>NONE</td><td>1</td></tr> <tr><td>1</td><td>SCH</td><td>INS_BUSY</td><td>1</td><td>SCH</td><td>INS_BUSY</td><td>NONE</td><td>1</td></tr> <tr><td>2</td><td>TCH</td><td>INS_IDLE</td><td>FLOAT</td><td>TCH</td><td>INS_IDLE</td><td>NONE</td><td>FLOAT</td></tr> <tr><td>3</td><td>TCH</td><td>INS_IDLE</td><td>FLOAT</td><td>TCH</td><td>INS_IDLE</td><td>NONE</td><td>FLOAT</td></tr> <tr><td>4</td><td>TCH</td><td>INS_IDLE</td><td>FLOAT</td><td>TCH</td><td>INS_IDLE</td><td>NONE</td><td>FLOAT</td></tr> <tr><td>5</td><td>TCH</td><td>INS_IDLE</td><td>FLOAT</td><td>TCH</td><td>INS_IDLE</td><td>NONE</td><td>FLOAT</td></tr> <tr><td>6</td><td>TCH</td><td>INS_IDLE</td><td>FLOAT</td><td>TCH</td><td>INS_IDLE</td><td>NONE</td><td>FLOAT</td></tr> <tr><td>7</td><td>TCH</td><td>INS_IDLE</td><td>FLOAT</td><td>TCH</td><td>INS_IDLE</td><td>NONE</td><td>FLOAT</td></tr> <tr><td>8</td><td>TCH</td><td>INS_IDLE</td><td>FLOAT</td><td>TCH</td><td>INS_IDLE</td><td>NONE</td><td>FLOAT</td></tr> <tr><td>9</td><td>TCH</td><td>INS_IDLE</td><td>FLOAT</td><td>TCH</td><td>INS_IDLE</td><td>NONE</td><td>FLOAT</td></tr> <tr><td>10</td><td>TCH</td><td>INS_IDLE</td><td>FLOAT</td><td>TCH</td><td>INS_IDLE</td><td>NONE</td><td>FLOAT</td></tr> <tr><td>11</td><td>TCH</td><td>INS_IDLE</td><td>FLOAT</td><td>TCH</td><td>INS_IDLE</td><td>NONE</td><td>FLOAT</td></tr> <tr><td>12</td><td>TCH</td><td>INS_IDLE</td><td>FLOAT</td><td>TCH</td><td>INS_IDLE</td><td>NONE</td><td>FLOAT</td></tr> <tr><td>13</td><td>TCH</td><td>INS_IDLE</td><td>FLOAT</td><td>TCH</td><td>INS_IDLE</td><td>NONE</td><td>FLOAT</td></tr> <tr><td>14</td><td>TCH</td><td>INS_IDLE</td><td>FLOAT</td><td>TCH</td><td>INS_IDLE</td><td>NONE</td><td>FLOAT</td></tr> <tr><td>15</td><td>TCH</td><td>INS_IDLE</td><td>FLOAT</td><td>TCH</td><td>INS_IDLE</td><td>NONE</td><td>FLOAT</td></tr> </tbody> </table>	CF	MMCONF	MMSTATE	MMSECTOR	PHYCONF	PHYSTATE	PHYREASON	PHYSECTOR	--	-----	-----	-----	-----	-----	-----	-----	0	PCH_ACH	INS_BUSY	1	PCH_ACH	INS_BUSY	NONE	1	1	SCH	INS_BUSY	1	SCH	INS_BUSY	NONE	1	2	TCH	INS_IDLE	FLOAT	TCH	INS_IDLE	NONE	FLOAT	3	TCH	INS_IDLE	FLOAT	TCH	INS_IDLE	NONE	FLOAT	4	TCH	INS_IDLE	FLOAT	TCH	INS_IDLE	NONE	FLOAT	5	TCH	INS_IDLE	FLOAT	TCH	INS_IDLE	NONE	FLOAT	6	TCH	INS_IDLE	FLOAT	TCH	INS_IDLE	NONE	FLOAT	7	TCH	INS_IDLE	FLOAT	TCH	INS_IDLE	NONE	FLOAT	8	TCH	INS_IDLE	FLOAT	TCH	INS_IDLE	NONE	FLOAT	9	TCH	INS_IDLE	FLOAT	TCH	INS_IDLE	NONE	FLOAT	10	TCH	INS_IDLE	FLOAT	TCH	INS_IDLE	NONE	FLOAT	11	TCH	INS_IDLE	FLOAT	TCH	INS_IDLE	NONE	FLOAT	12	TCH	INS_IDLE	FLOAT	TCH	INS_IDLE	NONE	FLOAT	13	TCH	INS_IDLE	FLOAT	TCH	INS_IDLE	NONE	FLOAT	14	TCH	INS_IDLE	FLOAT	TCH	INS_IDLE	NONE	FLOAT	15	TCH	INS_IDLE	FLOAT	TCH	INS_IDLE	NONE	FLOAT
CF	MMCONF	MMSTATE	MMSECTOR	PHYCONF	PHYSTATE	PHYREASON	PHYSECTOR																																																																																																																																										
--	-----	-----	-----	-----	-----	-----	-----																																																																																																																																										
0	PCH_ACH	INS_BUSY	1	PCH_ACH	INS_BUSY	NONE	1																																																																																																																																										
1	SCH	INS_BUSY	1	SCH	INS_BUSY	NONE	1																																																																																																																																										
2	TCH	INS_IDLE	FLOAT	TCH	INS_IDLE	NONE	FLOAT																																																																																																																																										
3	TCH	INS_IDLE	FLOAT	TCH	INS_IDLE	NONE	FLOAT																																																																																																																																										
4	TCH	INS_IDLE	FLOAT	TCH	INS_IDLE	NONE	FLOAT																																																																																																																																										
5	TCH	INS_IDLE	FLOAT	TCH	INS_IDLE	NONE	FLOAT																																																																																																																																										
6	TCH	INS_IDLE	FLOAT	TCH	INS_IDLE	NONE	FLOAT																																																																																																																																										
7	TCH	INS_IDLE	FLOAT	TCH	INS_IDLE	NONE	FLOAT																																																																																																																																										
8	TCH	INS_IDLE	FLOAT	TCH	INS_IDLE	NONE	FLOAT																																																																																																																																										
9	TCH	INS_IDLE	FLOAT	TCH	INS_IDLE	NONE	FLOAT																																																																																																																																										
10	TCH	INS_IDLE	FLOAT	TCH	INS_IDLE	NONE	FLOAT																																																																																																																																										
11	TCH	INS_IDLE	FLOAT	TCH	INS_IDLE	NONE	FLOAT																																																																																																																																										
12	TCH	INS_IDLE	FLOAT	TCH	INS_IDLE	NONE	FLOAT																																																																																																																																										
13	TCH	INS_IDLE	FLOAT	TCH	INS_IDLE	NONE	FLOAT																																																																																																																																										
14	TCH	INS_IDLE	FLOAT	TCH	INS_IDLE	NONE	FLOAT																																																																																																																																										
15	TCH	INS_IDLE	FLOAT	TCH	INS_IDLE	NONE	FLOAT																																																																																																																																										

---

# Site I/O Junction Box Replacement Procedure

## Objective

The objective of this procedure is to replace the Site I/O junction box.

## System Impact/Considerations

The removal of the failed Site I/O junction box will require system downtime. The BTS cannot report alarms without the Site I/O junction box. The other system level alarms are too numerous and outside the scope of this document.

## Required Tools and Materials

The following tools are required to remove the solar cover and install the new Site I/O junction box.

### Tools

- Torque driver wrench, 1/4-in. hex female drive, 0–10 N–M
- T20 Torx tamper bit
- T30 Torx tamper bit

### Replacement units

One Site I/O junction box is required – Kit T396AA

## Procedure to Replace Site I/O Junction Box

### Before you begin

Before you begin, enter the following information into the following replacement list table.

<b>Table 8-4: Item Number Replacement List</b>	
<b>Item</b>	<b>Number</b>
BTS number	
Failed Site I/O Junction Box number	

## Site I/O Junction Box Replacement Procedure – continued

### Remove the failed site I/O junction box

Follow the steps in Table 8-5 to remove the failed Site I/O junction box.

<b>Table 8-5: Remove the Failed Site I/O Junction Box</b>	
<b>Step</b>	<b>Action</b>
1	Place the BTS out of service using the “Shut Down Signaling Functions” procedure shown in Table 8-2.
2	Using a T20 Torx tamper bit, remove the Solar Cover if one is present and locate the failed Site I/O junction box.
3	If DC power is being supplied to the unit or if the battery backup is present, open (pull) the DC power breaker. The white collar on the breaker is visible when the breaker is opened.
4	If AC power is being supplied to the unit, open (pull) the AC power breaker. The white collar on the breaker is visible when the breaker is open.
5	Disconnect the unit ground cable from the Site I/O junction box.
6	Using a T30 Torx tamper bit, remove the two tamper resistant captive screws to disconnect the Site I/O junction box from the unit. See Figure 8-4.
7	If your BTS is equipped with the customer-supplied Site I/O interface, then proceed to step 8. If your BTS is equipped with the optional Primary Surge Suppressor, then proceed to step 9.
8	Disconnect the Site I/O cable from the Deutsche connector on the Site I/O cable. Location of Site I/O interface is site-dependent.
9	Disconnect the Site I/O cable from the Primary Surge Suppressor.

### Install the replacement Site I/O junction box

Follow the steps in Table 8-6 to install the replacement Site I/O junction box.

<b>Table 8-6: Install the Replacement Site I/O Junction Box</b>	
<b>Step</b>	<b>Action</b>
1	Reconnect the Site I/O cable according to the “Site I/O, Span Line, RGPS and Modem Cabling” procedure in Chapter 4.
2	Install the replacement Site I/O junction box according to the “Mounting the Site I/O Junction Box to the Unit” procedure in Chapter 5.
3	Attach the ground cable from the mounting bracket to the Site I/O junction box.
4	If AC power is being supplied to the unit, close (push) the AC power breaker. The white collar on the breaker is not visible when the breaker is closed.
5	If DC power is being supplied to the unit or if battery backup is present, close (push) the DC power breaker. The white collar on the breaker is not visible when the breaker is closed.
6	Install the Solar Cover if one is present according to the “Mounting Solar Cover and Powering on Unit” procedure in Chapter 5.
7	Place the BTS back in service using the “Restore Signaling Operations” procedure in Table 8-3.

# Site I/O Junction Box Replacement Procedure – continued

## Site I/O Junction Box Location Diagram

Figure 8-4: Site I/O Junction Box Replacement

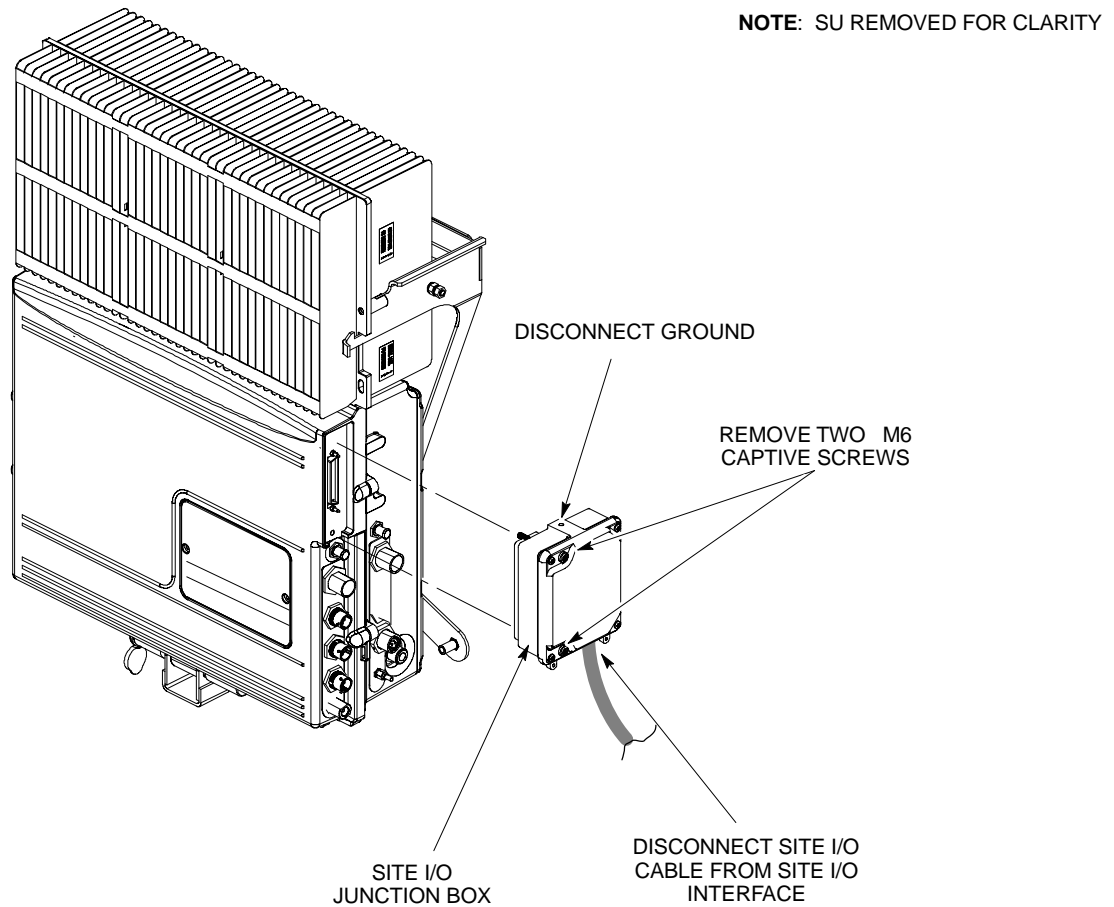

# Short Duration Battery Replacement Procedures

## Objective

The objective of this procedure is to replace the short duration battery.

## Required Tools and Materials

The following tools are required to remove the solar cover and install the new battery.

### Tools

Attaching the battery to the unit requires:

- T20 Torx tamper bit, 1/4-in. hex
- T30 Torx tamper bit, 1/4-in. hex
- Torque driver wrench, 1/4-in. hex female drive, 0–10 N–M
- Two (2) Screws M6x19 (Motorola Part Number 0387541C03)

### Replacement units

One Battery – Kit T392AA is necessary for this procedure.

## Procedure to Replace Short Duration Battery

### Before you begin

Before you begin, enter the following information into the following replacement list table.

<b>Table 8-7: Item Number Replacement List</b>	
<b>Item</b>	<b>Number</b>
BTS number	
Failed Battery number	

### Remove the failed battery

Follow the steps in Table 8-8 to remove the failed battery. Refer to NO TAG.

#### NOTE

The short duration battery is designed to be replaced with the DC breaker closed (pushed). If the DC breaker is opened (pulled) during this procedure, the BTS must be taken off-line and restarted to ensure proper battery fault management.

<b>Table 8-8: Procedure to Remove the Failed Short Duration Battery</b>	
<b>Step</b>	<b>Action</b>
1	Turn the DC Power Breaker off.
2	Use a T20 Torx tamper bit to remove the Solar Cover (if one is present) and locate the battery.
. . . continued on next page	

---

## Short Duration Battery Replacement Procedure – continued

**Table 8-8:** Procedure to Remove the Failed Short Duration Battery

Step	Action
3	Turn the connector on the short duration battery cable counterclockwise to disconnect the cable from the unit. See NO TAG. An alarm will be generated.
4	Using a T30 Torx tamper bit remove the two screws that are holding the battery to the unit. See NO TAG.

### Install the replacement battery

Follow the steps in Table 8-8 to install the replacement short duration battery. Refer to NO TAG.

**Table 8-9:** Procedure to Install the Replacement Short Duration Battery

Step	Action
1	Install the replacement battery according to the “Attaching the Battery to the Unit” installation procedure in Chapter 5.
2	Re-connect the short-duration battery cable to DC input connector. See Figure 8-5. The alarm will clear.
3	Re-install the Solar Cover if one is present.

# Short Duration Battery Replacement Procedure – continued

Figure 8-5: Short Duration Battery Replacement

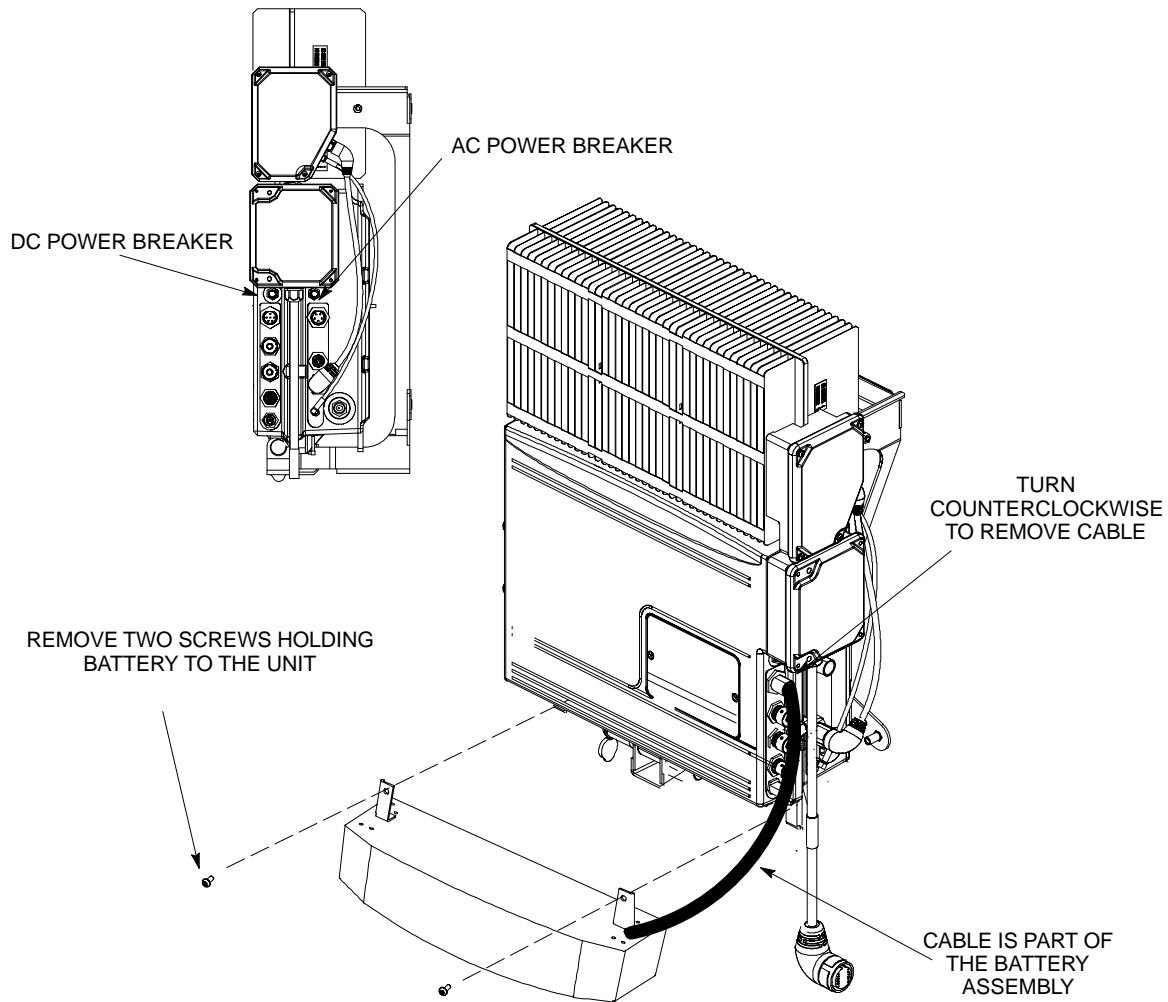

# Remote GPS Replacement Procedure

## Objective

The objective of this procedure is to replace the RGPS head.

## Required Tools and Materials

### Replacement units

One RGPS head with cable attached (Motorola Kit T472AP) is required to do this procedure.

## Procedure to Replace Remote GPS

### Before you begin

Before you begin, enter the following information into the following replacement list table.

<b>Table 8-10: Item Number Replacement List</b>	
<b>Item</b>	<b>Number</b>
BTS number	
Failed RGPS head number	

### Remove the failed RGPS head

Follow the steps in Table 8-11 to remove the failed RGPS head. Refer to Figure 8-6.

<b>Table 8-11: Procedure to Remove the Failed RGPS Head</b>	
<b>Step</b>	<b>Action</b>
1	<b>NOTE</b> To prevent twisting of cables, do not unscrew or screw the RGPS head while holding the pipe/conduit. Loosen the pipe/conduit mounting hardware until the pipe/conduit is free to be unscrewed from the RGPS head.
2	Grasp the RGPS head with one hand and the pipe/conduit with the other hand. Unscrew the pipe/conduit from the head and separate the head from the pipe/conduit. Grasp the cable just below the head and pull about 16 inches of cable out of the pipe/conduit until the mating cable connectors are exposed.
3	Separate the mating cable connectors to disconnect the RGPS head from the RGPS cable.



**Install the replacement RGPS head**

Follow the steps in Table 8-12 to install the replacement RGPS head. Refer to Figure 8-6.

<b>Table 8-12: Procedure to Install the Replacement RGPS Head</b>	
<b>Step</b>	<b>Action</b>
1	Connect the cable connector of the replacement RGPS head to the RGPS cable connector. Secure the connection by tightening the spinning connector flange.
2	Feed the cable slack into the RGPS head end of the mounting pipe/conduit.
3	Grasp the RGPS head with one hand and the pipe/conduit with the other hand. Be careful not to cross-thread the fitting on the RGPS head, screw the pipe/conduit into the head. Hand tighten only!
4	Tighten the pipe/conduit mounting hardware until the pipe/conduit is securely mounted.

**Figure 8-6: RGPS Head Replacement**

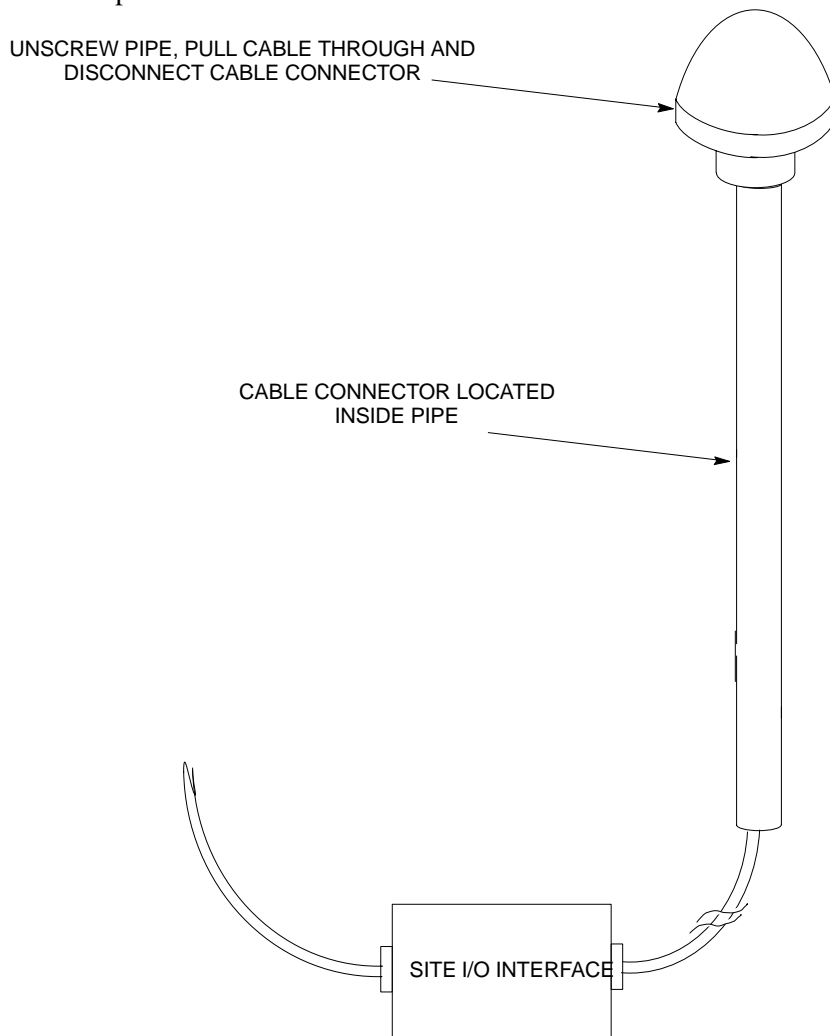

# Full Unit Replacement Procedures

## Objective

The objective of this procedure is to replace a Microcell unit. See NO TAG.

## System Impact/Considerations

The removal of the failed unit will require system downtime.

## Required Tools and Materials

The following tools and materials are required to do this procedure:

### Tools

The following tools are required to do this procedure:

- Torque driver wrench, 1/4-in. hex female drive, 0–10 N–M
- T20 TORX Tamper Bit, 1/4-in. hex
- T30 TORX Tamper Bit, 1/4-in. hex
- 13 mm torque wrench set to 5.0 N–M
- 5/16 breakaway torque wrench 9-in. lb.
- 13/16 breakaway torque wrench 38-in. lb.
- Key for lock (optional)
- Handles for unit (optional)

### Replacement units

One Microcell unit is required to do this procedure.

## Procedure to Replace Failed Unit

### Before you begin

Before you begin, enter the following information into the following replacement list table.

Table 8-13: Item Number Replacement List	
Item	Description
BTS Number	
Failed Unit Number	

### Remove the failed unit

Follow the steps in Table 8-14 to remove the failed unit.

Table 8-14: Procedure to Remove the Failed Unit	
Step	Action
1	Place the BTS out of service. Refer to the “Shut Down Signaling Functions” procedure in Table 8-2.
2	If necessary, use a T20 TORX Tamper bit to remove the Solar Cover.
. . . continued on next page	

## Full Unit Replacement Procedures – continued

**Table 8-14:** Procedure to Remove the Failed Unit

<b>Step</b>	<b>Action</b>
3	If DC power is being supplied to the unit or if battery backup is present, open (pull) the DC power breaker. The white collar on the breaker is visible when the breaker is opened.
4	If AC power is being supplied to the unit, open (pull) the AC power breaker. The white collar on the breaker is visible when the breaker is opened.
5	Turn the power off at the main power source (AC and/or DC).
6	Use a T30 TORX tamper bit to remove the two tamper-resistant screws that hold the site I/O junction box (or site I/O cap) to the BTS. Refer to Figure 8-4 in the “Site I/O Junction Box Replacement” procedure.
7	Disconnect the AC input cable from the unit. Refer to NO TAG.
8	Disconnect the DC input cable from the unit. Refer to NO TAG.
9	Disconnect the antenna cable(s) from the unit. Refer to NO TAG.
10	Disconnect the MIB cables from the unit (if equipped). Refer to NO TAG.
11	Disconnect the SU cables from the unit (if equipped). Refer to NO TAG.
12	Remove the two mounting screws that hold the short duration battery (if present) to the unit. Refer to Table 8-8 in the “Short Duration Battery Replacement Procedures” procedure and NO TAG.
13	Attach the installation handles to the unit. Refer to the “Attaching Installation Handles to the Unit” procedure in Chapter 6.
14	Use a T30 Tamper bit to remove the two screws that hold the unit to the mounting bracket.
15	Remove the pin or lock (if equipped) from the unit.
16	Remove the unit from the mounting bracket.

### Install the replacement unit

Follow the steps in Table 8-15 to install the replacement unit.

<b>Table 8-15: Procedure to Install the New Unit</b>	
<b>Step</b>	<b>Action</b>
1	Attach the installation handles to the replacement unit. Refer to the “Attaching Installation Handles to Unit” procedure in Chapter 6.
2	Mount the replacement unit to the bracket. Refer to the “Attaching Unit to the Mounting Bracket” procedure in Chapter 6.
3	Once the replacement unit has been secured to the mounting bracket, remove the installation handles (reverse the installation order of the “Attaching Installation Handles to the Unit” procedure in Chapter 6).
4	Attach the site I/O junction box or site I/O cap to the unit. Refer to the “Attaching the Site I/O Junction Box to the Unit” procedure in Chapter 6 and Figure 8-4.
5	Attach the short duration battery (if present) to the unit. Refer to Table 8-9 in the “Short Duration Battery Replacement Procedure” and NO TAG.
6	Connect the AC input cable. Refer to the “AC Power Cabling” procedure in Chapter 6.
7	Connect the DC input cable. Refer to the “DC Power Cabling” procedure in Chapter 6.
8	Connect the antenna cable(s). Refer to the “Antenna Cabling” procedure in Chapter 6.
9	Connect the MIB cables (if equipped). Refer to the “MIB Cabling” procedure in Chapter 6.
10	Connect the SU cables (if equipped). Refer to the “SU Cabling” procedure in Chapter 6.
11	Turn power on at the main power source (AC and/or DC).
12	If AC power is being supplied to the unit, close (push) the AC power breaker. The white collar on the breaker is not visible when the breaker is closed.
13	If DC power is being supplied to the unit or if battery backup is present, close (push) the DC power breaker. The white collar is not visible when the breaker is closed.
14	Perform the ATP, if necessary. Refer to the ATP procedures in Chapter 7.
15	Install the Solar Covers (if necessary).
16	Place the BTS back in service using the “Restore Signaling Operations” procedure in Table 8-3.

# Full Unit Replacement Procedures – continued

**Figure 8-7: Unit Replacement**

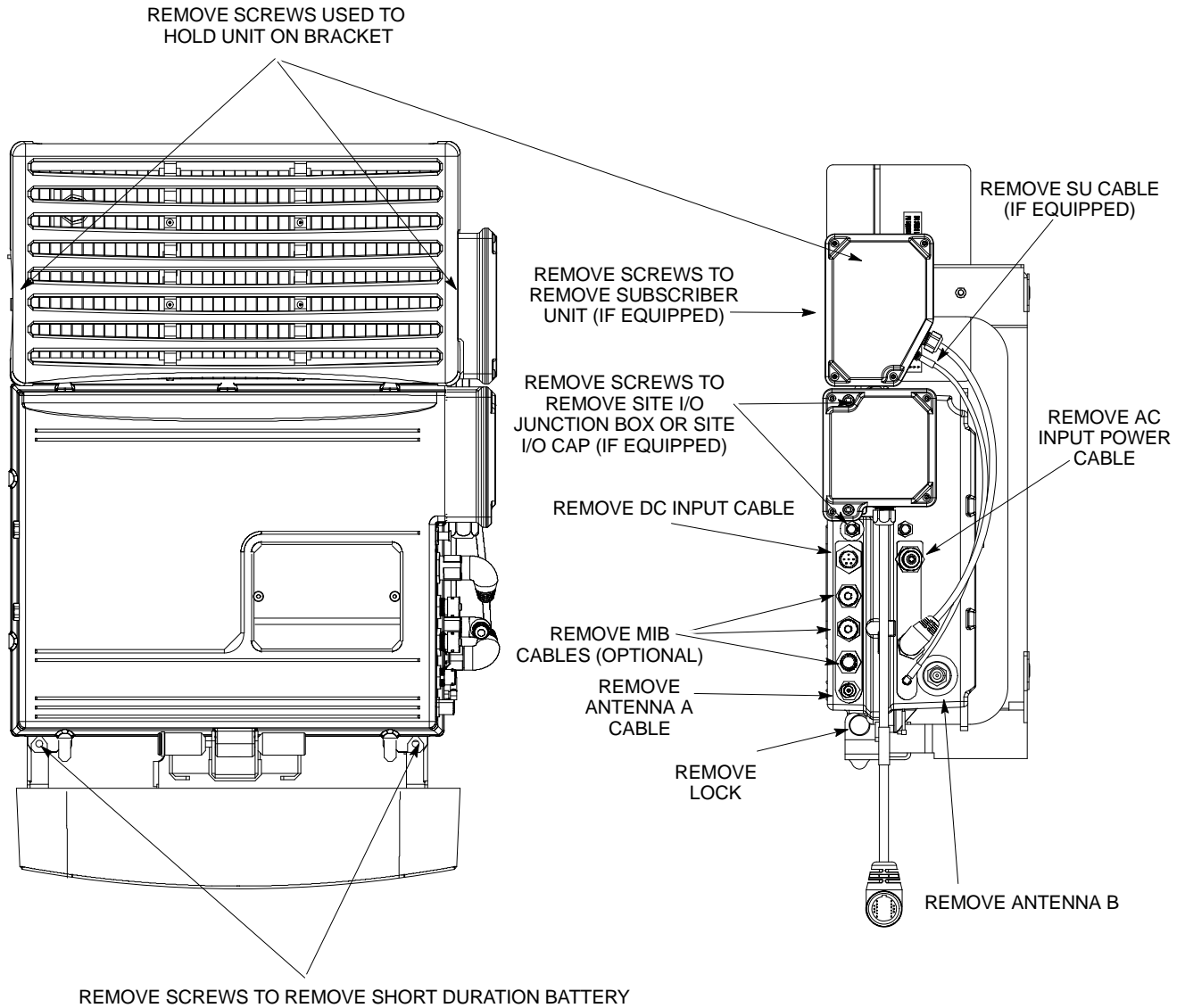

**NOTE:** REMOVE THE SITE I/O JUNCTION BOX (OR SITE I/O CAP), SUBSCRIBER UNIT, AND BATTERY FROM THE FAILED UNIT AND RE-MOUNT THEM ON THE REPLACEMENT UNIT



## Appendix A: Outdoor Grounding Guidelines Overview

### Appendix Content

---

Outdoor Grounding Guidelines Summary .....	A-1
Background .....	A-1
Chassis Isolation .....	A-1
Master Ground Plate .....	A-1
Main AC Power .....	A-1
Antenna .....	A-1
Chassis .....	A-2
T1 Span Lines .....	A-2
Modem .....	A-2
Customer I/O .....	A-2





## Background

This is a summary of the outdoor grounding guidelines. Outdoor installations should be based on this summary and site specific documentation. Motorola publication 68P81150E62 should also be followed to ground an antenna tower.

This guideline assumes that auxiliary equipment is co-located at the installation site. All of the equipment referenced may not be present at every site.

Because outdoor MicroCell installations will involve a variety of methods, this information is not meant to represent actual physical layout. It is meant to act as an aid to understanding an effective ground system.

## Chassis Isolation

Regardless of the type of installation (wall, frame, pole), the grounding plan must have a single point ground to prevent surge/transient currents from passing through the BTS and auxiliary equipment. The BTS includes insulation hardware to insure that the chassis will be grounded by the intended ground path and not through the mounting structure (frame, pole, or wall).

## Master Ground Plate

The Master Ground Plate (MGP) is the key to the outdoor grounding scheme. The MGP is the single grounding point for all BTS input and output and provides a uniform ground potential through out the site.

Although the MGP may be implemented differently at each installation, it must be a plate that is big enough to attach to all the lightning arrestors and have a ground stud.

The MGP ground stud is the only connection to earth ground for the BTS hardware.

## Main AC Power

The AC power input is single-phase and connects to the BTS by a three conductor cable. The cable is insulated and connects to the BTS on one end and the AC source on the other end. The AC power source should be ground referenced to the MGP at a point closest to the access point. The line and neutral conductors must be protected by lightning arrestors. The lightning arrestors connect to the MGP at the same point as the AC ground reference.

If an external circuit breaker or an uninterruptible power supply are used, install them between the AC power lightning arrestor and the BTS.

## Antenna

Coaxial cables are used to connect to the antenna(s). The ground conductor (shield) of the coaxial cable must be ground referenced to the

---

## Outdoor Grounding Guidelines Summary – continued

MGP at the antenna access point. The signal (center) conductor must be protected by a lightning arrester. The lightning arrester connects to the MGP at the same point as the ground conductor (shield) of the antenna cable.

### Chassis

The ground stud of the BTS chassis connects to the MGP.

### T1 Span Lines

The BTS can connect to two T1 span lines. For many applications the T1 cable is derived from an optical fiber interconnect. For cases where the optical interconnect is non-metallic, no special grounding is needed. If the optical fiber is encased in a metallic sheath, the sheath must be grounded to the MGP. If the span lines are metallic, the conductors must be protected by lightning arrestors which connect to the MGP at a point closest to the demarcation point.

### Modem

A single tip and ring pair is used for a dial-up modem connection. The tip and ring pair must be protected by a lightning arrester which connects to the MGP at a point closest to the demarcation point.

### Customer I/O

The BTS provides eight customer defined inputs. These connections are internal to the cell site and do not require special grounding unless they originate from an area not protected by the MGP.

Example: Signal light in tower configuration

**Appendix B: Alarm List**



**Appendix Content**

---

Release 15 Alarm List .....	B-1
Objective .....	B-1
List of Alarms .....	B-1



# Release 15 Alarm List

## Objective

Table B-1 lists all the alarms which can be generated by an SC™ 300 BTS. Additional Data field values are not shown. The list of alarms is based on R15 SC™ 300 functionality.

## List of Alarms

Table B-1: List of Alarms (Software Release 15)		
Alarm #	Alarm Name	Alarm Description
400	Traffic Channel Element Failure	This trouble notification indicates the availability of a single channel element or a set of channel elements. It is generated whenever the BTS detects an alarm condition on a DSP, its internal path connection, or its associated span. It is never displayed or latched in the MM and it is only used to update the MM's call processing resource list. This trouble notification contains the address of the channel card along with the list of affected channel elements.
1200	BTS LAN Connection Error	This alarm causes the MM to take the BTS out of service. The MM converts the alarm ID from 1200 to 12-60 (MAWI out of service).
<b>Call Overload Alarms</b>		
1950	BTS Overload: New Calls Threshold 1 Reached	A capacity overload alarm indicates that the new calls capacity ceiling was reached and mobile restrictions associated with the alarm will be in effect for the call setups. This alarm is cleared when the overload condition is no longer in effect. The reporting mechanism is disabled by default for all overload alarms in this category and can be changed via the Recent Change command <b>EDIT CARRIER/SECTOR/BTS CONGESTCONF</b> at the OMCR. Supplemental data represents the state of the system after the alarm actions have taken place.
1951	BTS Overload: New Calls Threshold 2 Reached	A capacity overload alarm indicates that the new calls capacity ceiling was reached and mobile restrictions associated with the alarm will be in effect for the call setups. This alarm is cleared when the overload condition is no longer in effect. The reporting mechanism is disabled by default for all overload alarms in this category and can be changed via the Recent Change command <b>EDIT CARRIER/SECTOR/BTS CONGESTCONF</b> at the OMCR. Supplemental data represents the state of the system after the alarm actions have taken place.
1952	BTS Overload: New Calls Threshold 3 Reached	A capacity overload alarm indicates that the new calls capacity ceiling was reached and mobile restrictions associated with the alarm will be in effect for the call setups. This alarm is cleared when the overload condition is no longer in effect. The reporting mechanism is disabled by default for all overload alarms in this category and can be changed via the Recent Change command <b>EDIT CARRIER/SECTOR/BTS CONGESTCONF</b> at the OMCR. Supplemental data represents the state of the system after the alarm actions have taken place.

B

**Table B-1:** List of Alarms (Software Release 15)

Alarm #	Alarm Name	Alarm Description
1953	BTS Overload: Registration Threshold 1 Reached	A capacity overload alarm indicates that the new calls capacity ceiling was reached and mobile restrictions associated with the alarm will be in effect for the call setups. This alarm is cleared when the overload condition is no longer in effect. The reporting mechanism is disabled by default for all overload alarms in this category and can be changed via the Recent Change command <b>EDIT CARRIER/SECTOR/BTS CONGESTCONF</b> at the OMCR. Supplemental data represents the state of the system after the alarm actions have taken place.
1954	BTS Overload: Registration Threshold 2 Reached	A capacity overload alarm indicates that the new calls capacity ceiling was reached and mobile restrictions associated with the alarm will be in effect for the call setups. This alarm is cleared when the overload condition is no longer in effect. The reporting mechanism is disabled by default for all overload alarms in this category and can be changed via the Recent Change command <b>EDIT CARRIER/SECTOR/BTS CONGESTCONF</b> at the OMCR. Supplemental data represents the state of the system after the alarm actions have taken place.
1955	BTS Overload: Registration Threshold 3 Reached	A capacity overload alarm indicates that the new calls capacity ceiling was reached and mobile restrictions associated with the alarm will be in effect for the call setups. This alarm is cleared when the overload condition is no longer in effect. The reporting mechanism is disabled by default for all overload alarms in this category and can be changed via the Recent Change command <b>EDIT CARRIER/SECTOR/BTS CONGESTCONF</b> at the OMCR. Supplemental data represents the state of the system after the alarm actions have taken place.
1956	BTS Overload: Aggregate Access Threshold 1 Reached	A capacity overload alarm indicates that the new calls capacity ceiling was reached and mobile restrictions associated with the alarm will be in effect for the call setups. This alarm is cleared when the overload condition is no longer in effect. The reporting mechanism is disabled by default for all overload alarms in this category and can be changed via the Recent Change command <b>EDIT CARRIER/SECTOR/BTS CONGESTCONF</b> at the OMCR. Supplemental data represents the state of the system after the alarm actions have taken place.
1957	BTS Overload: Aggregate Access Threshold 2 Reached	A capacity overload alarm indicates that the new calls capacity ceiling was reached and mobile restrictions associated with the alarm will be in effect for the call setups. This alarm is cleared when the overload condition is no longer in effect. The reporting mechanism is disabled by default for all overload alarms in this category and can be changed via the Recent Change command <b>EDIT CARRIER/SECTOR/BTS CONGESTCONF</b> at the OMCR. Supplemental data represents the state of the system after the alarm actions have taken place.

**Table B-1:** List of Alarms (Software Release 15)

Alarm #	Alarm Name	Alarm Description
1958	BTS Overload: Aggregate Access Threshold 3 Reached	A capacity overload alarm indicates that the aggregate of both call setups and registration capacity ceiling was reached and mobile restrictions associated with the alarm will be in effect for the mobile originations and registrations. This alarm is cleared when the overload condition is no longer in effect. The reporting mechanism is disabled by default for all overload alarms in this category and can be changed via Recent Change command <b>EDIT CARRIER/SECTOR/BTS CONGESTCONF</b> at OMCR. Supplemental data represents the state of the system after the alarm actions have taken place.
1959	Global Service Redirection Threshold Reached: New Calls	This alarm indicates that all mobiles in the affected access class will be redirected to an overlaid analog system or to another CDMA system until the rate drops below the threshold level for new calls. This alarm is cleared when the overload condition is no longer in effect. The default is set to <b>DISABLED</b> for all overload alarms in this category and can be changed via the Recent Change command <b>EDIT CARRIER/SECTOR/BTS CONGESTCONF</b> at the OMCR. Supplemental data represents the state of the system after the alarm actions have taken place.
1960	Global Service Redirection Threshold Reached: Registrations	This alarm indicates that all mobiles in the affected access class will be redirected to an overlaid analog system or to another CDMA system until the rate drops below the threshold level for new calls. This alarm is cleared when the overload condition is no longer in effect. The default is set to <b>DISABLED</b> for all overload alarms in this category and can be changed via the Recent Change command <b>EDIT CARRIER/SECTOR/BTS CONGESTCONF</b> at the OMCR. Supplemental data represents the state of the system after the alarm actions have taken place.
1961	Global Service Redirection Threshold Reached: Aggregate	This alarm indicates that all mobiles in the affected access class will be redirected to an overlaid analog system or to another CDMA system until the rate drops below the threshold level for new calls. This alarm is cleared when the overload condition is no longer in effect. The default is set to <b>DISABLED</b> for all overload alarms in this category and can be changed via the Recent Change command <b>EDIT CARRIER/SECTOR/BTS CONGESTCONF</b> at the OMCR. Supplemental data represents the state of the system after the alarm actions have taken place.
<b>LPAC Alarms</b>		
3901	LPAC: High Power Over Limit Alarm – Unit A	The output detector on the unit monitors the output power. An alarm generates when the output power surpasses a preset threshold. At this point, the PA is outputting more power than it can sustain, and damage will result if the PA continues to operate. A typical scenario that would cause a high power over limit alarm would be when power into the PA is more than it can safely sustain. This would cause an input overload, which is detected by the output detector, and the BTS would automatically reduce its output power. The BTS will remain in service after this alarm. Some calls may be dropped.





**Table B-1:** List of Alarms (Software Release 15)

Alarm #	Alarm Name	Alarm Description
3921	LPAC: Very High Temperature Alarm – Unit A	This alarm is generated when the temperature on the PA unit exceeds the threshold value for very high temperatures. This is either an equipment alarm suggesting a hardware failure, or an alarm indicating environmental extremes. To avoid equipment damage, the PA will automatically shut down. This will also cause the BTS to reboot.
3931	LPAC: High Temperature Alarm – Unit A	This alarm is generated when the temperature on the PA unit exceeds the threshold value for very high temperature. This is either an equipment alarm suggesting a hardware failure, or an alarm indicating environmental extremes. The BTS will reboot automatically to avoid equipment damage.
3941	LPAC: VSWR Alarm – Unit A	This alarm indicates a VSWR alarm was detected on the PA unit. This is an equipment alarm, suggesting a hardware failure of the antenna system, which is external to the PA.  This alarm is considered capacity-limiting because the BTS will reboot automatically.
3961	LPAC: IM Loop Not Converged Alarm – Unit A	This alarm is generated when the convergence loop on the PA unit is unable to cancel the distortion components created by the PA such that the PA meets proper specifications. This alarm is detected by monitoring and measuring IM products. An alarm will generate if the readings fall below a preset threshold. The BTS will reboot automatically.
3980	LPAC Combination Alarm, Complete Sector Failure	This alarm is generated when the LPAC reports at least one of the following alarms: <ul style="list-style-type: none"> <li>• Very High Temperature Alarm,</li> <li>• IM Loop Not Converged Alarm,</li> <li>• VSWR Alarm</li> </ul> A combination alarm indicates a complete BTS reboot. Therefore, the sector has lost power and is no longer transmitting. Calls will neither originate to the failed sector, nor will existing calls hand off.
<b>RF Related Alarms</b>		
9141	Forward Power Very High Alarm: Sector 1	This alarm is generated whenever the P out of N forward gain samples (where N and P may be configured) exceed a configurable forward gain threshold. Two alarm levels can be specified: a very high (first level) and a high (second level). The order of alarming by increasing severity is normal condition, then high (second level), followed by very high (first level). A forward power very high alarm clear is generated whenever P out of N forward gain samples fall below the forward threshold minus a forward gain Delta.



**Table B-1:** List of Alarms (Software Release 15)

Alarm #	Alarm Name	Alarm Description
9151	Reverse Noise Rise Very High Alarm: Sector 1	This alarm is generated whenever a reverse noise rise measurement (rolling average over a configurable number of samples) exceeds a reverse noise rise threshold. Two alarm levels can be specified: a very high (first level) and a high (second level). The order of alarming by increasing severity is normal condition, then high (second level), followed by very high (first level). A Reverse Noise Rise Very High Alarm clear is generated whenever the reverse noise rise measurement recedes below the reverse noise rise threshold minus a Delta.
9161	Forward Power High Alarm: Sector 1	This alarm is generated whenever the P out of N forward gain samples (where N and P may be configured) exceed a configurable forward gain threshold. Two alarm levels can be specified: a very high (first level) and a high (second level). The order of alarms listed by increasing severity is: normal condition, high (second level), and very high (first level). A Forward Power High Alarm Clear is generated whenever P out of N forward gain samples fall below the forward threshold minus a forward gain Delta.
9171	Reverse Noise Rise High Alarm: Sector 1	This alarm is generated whenever a reverse noise rise measurement (rolling average over a configurable number of samples) exceeds a reverse noise rise threshold. Two alarm levels can be specified: a very high (first level) and a high (second level). The order of alarms listed by increasing severity are: normal condition, high (second level), and very high (first level). A Reverse Noise Rise High Alarm Clear is generated whenever the reverse noise rise measurement recedes below the reverse noise rise threshold minus a delta.
9210	Forward Power Limiting Alarm	When the Forward Power Limiting alarm is activated, the BTS controller will instruct the CDMA transceiver to limit the forward power at or below the current peak power level (or at a fixed power level) or to reduce the forward gain by a fixed amount. A Forward Power Limiting Alarm is generated whenever the forward power exceeds the user definable fixed power threshold (fixed limit mode), or the forward gain measurement exceeds the forward gain limiting threshold (self-calibrating limit mode). A Forward Power Limiting Alarm Clear is generated whenever the forward power falls below the power limit threshold minus a clear event delta (fixed limit mode) or the forward gain measurement falls below the forward gain limiting threshold minus a forward gain limiting delta (self-calibrating limit mode).
9211	Forward Power Limiting Alarm – Recovery Attempts Exceeded	This alarm is generated when the system has tried to recover the LPA over-driven condition for the user-configurable maximum number of times and the over-driven condition still exist. This alarm is only applicable for the self-calibrating limit mode.
<b>Synchronization Alarms</b>		
10030	Lost Phase Lock	This alarm is generated when the active BTS DPLL loses phase lock and re-enters acquisition mode. If the BTS does not regain phase lock, or repeatedly gains and loses phase lock, the problem is most likely a hardware problem in the unit.



B

**Table B-1:** List of Alarms (Software Release 15)

Alarm #	Alarm Name	Alarm Description
10040	GPS Reference Source Failure	<p>This alarm is generated when the BTS detects a failure (missing clock pulses or associated device not ready) of its GPS reference source. The additional alarm data will include information about the reference source priority. The reference source priority is the priority of the GPS reference source in relation to the other available reference sources.</p> <p>This alarm will report when local conditions prevent proper GPS reception or when the GPS system is taken down for configuration. If the GPS reference source does not recover or repeatedly fails, a problem may exist in the GPS receiver hardware. This alarm is only reported after the GPS is lost for more than 30 seconds. The loss of GPS for shorter periods of time is not considered unusual, especially if the antenna placement is less than optimum. Short losses of GPS will have no impact on the performance of the BTS.</p>
10060	GPS Message Failure	<p>This alarm is generated when the BTS receives a message from the GPS receiver that cannot be processed. The additional info will indicate if the message problem was due to an unknown type, checksum failure, format failure, incomplete message (timeout during message reception) or remote GPS cable delay compensation failure. This alarm is provided to allow additional status to be tracked.</p>
10091	HSO Reference Source Failure	<p>This alarm is generated when the BTS detects a failure (missing clock pulses) of its High Stability Oscillator (HSO) reference source. The additional alarm data will include information about the reference source priority. The reference source priority is the priority of the Rubidium reference source in relation to the other available reference sources.</p> <p>If the Rubidium reference source does not recover or repeatedly fails, a problem may exist in the Rubidium Reference Source hardware.</p>
10100	No Reference Source Available	<p>This alarm is generated when the BTS detects a failure of all of its available reference sources.</p>
10110	Reference Source Switch	<p>This alarm is generated when the BTS switches to an alternate reference source. The additional alarm data will identify the alternate reference source type (GPS, HSO, HSO2 – if sync daisy chain is used or freerun). A reference source switch occurs when a reference source fails and an alternate reference source is available. The reference source switch is seamless and does not cause degradation in system performance</p>
10111	Reference Source Unreliable	<p>This alarm is generated when the reporting device expires a given time period during which its reference source is known to provide a reliable clock for the maintenance of CDMA system time. Once the alarm is generated, it is possible that the reporting device is running with a clock that has drifted from CDMA system time. If so, the reporting device will continue to support call originations and maintenance, but cannot guarantee hand-off capability. The additional data will identify the reference source the device is currently using as a timing reference.</p>

**Table B-1:** List of Alarms (Software Release 15)

Alarm #	Alarm Name	Alarm Description
<b>HW Specific Alarms</b>		
1701–1708	BTS Relay #n – Contact Alarm	This alarm is active when a BTS input relay has opened or closed. The relay number “n” will be 1–8. This is an equipment alarm and suggests a possible hardware failure or operator–defined condition.
1800	BTS Controller Disabled Device	This alarm is active when the BTS Controller has detected a faulty device and is requesting that the device be disabled. The device is not responding to an update or has been implicated by a series of alarms.
12040	TRX Failure	This alarm is generated when a BTS detects a failure in its TRX. The additional data specifies the TRX failure. If the BTS is not a master device, the BTS will de–key its TRX and Ram Boot itself. If the BTS is a master device and it is in service, the master BTS shall de–key its troubled TRX and stay in service. Since there is a one–to–one relation between a BTS and its TRX, this will result in the sector going out of service.
12050	TRX Warning	This alarm is generated when a BTS detects a high temperature in its TRX. The additional data indicates the specific problem. The BTS will not de–key the TRX as a result of this alarm.
12060	Cabinet Temperature	This alarm is generated when a BTS detects a temperature threshold violation or a problem with the temperature sensing mechanism. The reason code indicates the exact error.
12071 – 12072	RXDC Failure Unit A/B	This alarm is generated when a BTS detects a failure in a particular RXDC unit. This is reported thru the RX and indicates a diversity problem within the site.
<b>CE Alarms</b>		
12100 – 12131	Channel Element Failure #n	<p>This alarm is generated when a BTS detects an unrecoverable error for a particular channel element (CE). The additional data indicates the specific error. The CE will be disabled automatically.</p> <p><b>NOTE</b> SC340 device has 16 channel elements, thus it does not detect and generate alarms 12116–12131.</p>
12200 – 12231	Channel Element Recovered #n	<p>This alarm is generated when a BTS detects a recoverable error for a particular Channel Element (CE). The additional data indicates the specific error. The CE has been recovered automatically. While in recovery mode, all active calls at the CE could be lost.</p> <p><b>NOTE</b> SC340 device has 16 channel elements, thus it does not detect and generate alarms 12216–12231.</p>



B

**Table B-1:** List of Alarms (Software Release 15)

Alarm #	Alarm Name	Alarm Description
12300 – 12331	Channel Element TSI Mapping Failure #n	<p>This alarm is generated when a BTS detects a problem internally allocating a SRCHAN to a particular channel element (CE). The additional data indicates the specific error. The CE is unusable for call processing.</p> <p><b>NOTE</b> The SC340 device has 16 channel elements, thus it does not detect and generate alarms 12316–12331.</p>
<b>Span Alarms</b>		
18001/ 18002	SPAN Degraded – Remote Fault Daily Threshold Exceeded (source)/(sink)	<p>This alarm indicates that the count of remote faults exceeded the alarm threshold (default threshold = 16) within a 24-hour period. This alarm is caused by the transmit span line path fading in and out. This alarm condition will have an insignificant impact on system performance and call quality. This alarm may provide an early warning of a more serious condition.</p> <p>This alarm will be sent by one of the two devices at the end of the span. In some cases, a second alarm will be sent by the device at the other end of the span. One alarm will have “(source)” to indicate that it came from the source end point, and the other will have “(sink)” to indicate that it came from the sink end point.</p>
18004/ 18005	SPAN Degraded – Remote Fault Hourly Threshold Exceeded (source)/(sink)	<p>This alarm indicates that the count of remote alarms exceeded the alarm threshold (default threshold = 20) within a 1-hour period. This alarm is caused by the transmit span line path fading in and out. This alarm condition may have a minor impact on system performance and call quality. This alarm may provide an early warning of a more serious condition. This alarm will be sent by one of the two devices at the end of the span. In some cases, a second alarm will be sent by the device at the other end of the span. One alarm will have “(source)” to indicate that it came from the source end point, and the other will have “(sink)” to indicate that it came from the sink end point.</p>
18007/ 18008	SPAN Degraded – Remote Fault Critical Threshold Exceeded (source)/(sink)	<p>This alarm indicates that the count of remote faults exceeded the alarm threshold (default threshold = 511) within a 24-hour period. This alarm is caused by the transmit span line path fading in and out. This alarm indicates that system performance and call quality is seriously degraded. This alarm will be sent by one of the two devices at the end of the span. In some cases, a second alarm will be sent by the device at the other end of the span. One alarm will have “(source)” to indicate that it came from the source end point, and the other will have “(sink)” to indicate that it came from the sink end point.</p>

**Table B-1:** List of Alarms (Software Release 15)

Alarm #	Alarm Name	Alarm Description
18010/ 18011	SPAN Out-of-Service – Continuous Remote Faults (source)/(sink)	<p>This alarm indicates that the span is out-of-service due to continuous remote faults being received for more than 0.5 seconds. This alarm indicates that the transmit span line signal was lost at the remote end, or the transmit framing words were corrupted at the remote end. This alarm will be sent by one of the two devices at the end of the span. In some cases, a second alarm will be sent by the device at the other end of the span. One alarm will have “(source)” to indicate that it came from the source end point, and the other will have “(sink)” to indicate that it came from the sink end point.</p>
18013/ 18014	SPAN Degraded – Frame Slip Daily Threshold Exceeded (source)/(sink)	<p>This alarm indicates that the number of frame slips exceeded the alarm threshold (default threshold = 4) within a 24-hour period. This alarm is caused by the master unit in the BTS not being synchronized with the inbound span line. This alarm condition will have an insignificant impact on system performance and call quality. This alarm may provide an early warning of a more serious condition. This alarm will be sent by one of the two devices at the end of the span.</p> <p>In some cases, a second alarm will be sent by the device at the other end of the span. One alarm will have “(source)” to indicate that it came from the source end point, and the other will have “(sink)” to indicate that it came from the sink end point.</p>
18016/ 18017	SPAN Degraded – Frame Slip Hourly Threshold Exceeded (source)/(sink)	<p>This alarm indicates that the number of frame slips exceeded the alarm threshold (default threshold = 10) within a 1-hour period. This alarm is caused by the BTS unit not being synchronized with the inbound span line. This alarm condition may have a minor impact on system performance and call quality. This alarm may provide an early warning of a more serious condition. This alarm will be sent by one of the two devices at the end of the span.</p> <p>In some cases, a second alarm will be sent by the device at the other end of the span. One alarm will have “(source)” to indicate that it came from the source end point, and the other will have “(sink)” to indicate that it came from the sink end point.</p>
18019/ 18020	SPAN Degraded – Frame Slip Critical Threshold Exceeded (source)/(sink)	<p>This alarm indicates that the number of frame slips exceeded the alarm threshold (default threshold = 255) within a 24-hour period. This alarm is caused by the BTS unit not being synchronized with the inbound span line. This alarm indicates that system performance and call quality is seriously degraded. This alarm will be sent by one of the two devices at the end of the span.</p> <p>In some cases, a second alarm will be sent by the device at the other end of the span. One alarm will have “(source)” to indicate that it came from the source end point, and the other will have “(sink)” to indicate that it came from the sink end point.</p>



B

**Table B-1:** List of Alarms (Software Release 15)

Alarm #	Alarm Name	Alarm Description
18031/ 18032	SPAN Out-of-Service – Continuous Framed AIS Faults (source)/(sink)	<p>This alarm indicates that the span is out-of-service due to continuous Framed Alarm Indication Signal (AIS) faults being received for more than 2.5 seconds. This alarm indicates that the receive span signal was lost, the receive framing words were corrupted, or an incompatible remote span interface was detected by the network. This alarm will be sent by one of the two devices at the end of the span.</p> <p>In some cases, a second alarm will be sent by the device at the other end of the span. One alarm will have “(source)” to indicate that it came from the source end point, and the other will have “(sink)” to indicate that it came from the sink end point.</p>
18034/ 18035	SPAN Degraded – Unframed AIS Daily Threshold Exceeded (source)/(sink)	<p>This alarm indicates that the number of Unframed Alarm Indication Signal (AIS) alarms exceeded the alarm threshold (default threshold = 16) within a 24-hour period. This alarm is caused by the receive span fading in and out. This alarm condition will have an insignificant impact on system performance and call quality. This alarm may provide an early warning of a more serious condition. This alarm will be sent by one of the two devices at the end of the span.</p> <p>In some cases, a second alarm will be sent by the device at the other end of the span. One alarm will have “(source)” to indicate that it came from the source end point, and the other will have “(sink)” to indicate that it came from the sink end point.</p>
18037/ 18038	SPAN Degraded – Unframed AIS Hourly Threshold Exceeded (source)/(sink)	<p>This alarm indicates that the number of Unframed Alarm Indication Signal (AIS) alarms exceeded the alarm threshold (default threshold = 20) within a 1-hour period. This alarm is caused by the receive span fading in and out. This alarm condition may have a minor impact on system performance and call quality. This alarm may provide an early warning of a more serious condition. This alarm will be sent by one of the two devices at the end of the span.</p> <p>In some cases, a second alarm will be sent by the device at the other end of the span. One alarm will have “(source)” to indicate that it came from the source end point, and the other will have “(sink)” to indicate that it came from the sink end point.</p>
18040/ 18041	SPAN Degraded – Unframed AIS Critical Threshold Exceeded (source)/(sink)	<p>This alarm indicates that the number of Unframed Alarm Indication Signal (AIS) alarms exceeded the alarm threshold (default threshold = 511) within a 24-hour period. This alarm indicates that system performance and call quality is seriously degraded. This alarm will be sent by one of the two devices at the end of the span.</p> <p>In some cases, a second alarm will be sent by the device at the other end of the span. One alarm will have “(source)” to indicate that it came from the source end point, and the other will have “(sink)” to indicate that it came from the sink end point.</p>

**Table B-1:** List of Alarms (Software Release 15)

Alarm #	Alarm Name	Alarm Description
18043/ 18044	SPAN Out-of-Service – Continuous Unframed AIS Faults (source)/(sink)	<p>This alarm indicates that the span is out-of-service due to continuous Unframed Alarm Indication Signal (AIS) faults being received for more than 2.5 seconds. This alarm indicates that the receive span signal was lost, the receive framing words were corrupted, or an incompatible remote span interface was detected by the network. This alarm will be sent by one of the two devices at the end of the span.</p> <p>In some cases, a second alarm will be sent by the device at the other end of the span. One alarm will have “( source )” to indicate that it came from the source end point, and the other will have “( sink )” to indicate that it came from the sink end point.</p>
18046/ 18047	SPAN Degraded – REC Fault Daily Threshold Exceeded (source)/(sink)	<p>This alarm indicates that the number of Receive Error Condition (REC) alarms exceeded the alarm threshold (default threshold = 16) within a 24-hour period. This alarm condition will have an insignificant impact on system performance and call quality. This alarm may provide an early warning of a more serious condition. This alarm will be sent by one of the two devices at the end of the span.</p> <p>In some cases, a second alarm will be sent by the device at the other end of the span. One alarm will have “( source )” to indicate that it came from the source end point, and the other will have “( sink )” to indicate that it came from the sink end point.</p>
18049/ 18050	SPAN Degraded – REC Fault Hourly Threshold Exceeded (source)/(sink)	<p>This alarm indicates that the number of Receive Error Condition (REC) alarms exceeded the alarm threshold (default threshold = 20) within a 1-hour period. This alarm condition may have a minor impact on system performance and call quality. This alarm may provide an early warning of a more serious condition. This alarm will be sent by one of the two devices at the end of the span.</p> <p>In some cases, a second alarm will be sent by the device at the other end of the span. One alarm will have “( source )” to indicate that it came from the source end point, and the other will have “( sink )” to indicate that it came from the sink end point.</p>
18052/ 18053	SPAN Degraded – REC Fault Critical Threshold Exceeded (source)/(sink)	<p>This alarm indicates that the number of Receive Error Condition (REC) alarms exceeded the alarm threshold (default threshold = 511) within a 24-hour period. This alarm indicates that system performance and call quality is seriously degraded. This alarm will be sent by one of the two devices at the end of the span.</p> <p>In some cases, a second alarm will be sent by the device at the other end of the span. One alarm will have “( source )” to indicate that it came from the source end point, and the other will have “( sink )” to indicate that it came from the sink end point.</p>



B

B

**Table B-1:** List of Alarms (Software Release 15)

Alarm #	Alarm Name	Alarm Description
18055/ 18056	SPAN Out-of-Service – Continuous REC Faults (source)/(sink)	<p>This alarm indicates that the span is out-of-service due to continuous Receive Error Condition (REC) faults being received for more than 2.5 seconds. This alarm indicates that the receive span signal was lost, the receive framing words were corrupted, or an incompatible remote span interface was detected by the network. This alarm will be sent by one of the two devices at the end of the span.</p> <p>In some cases, a second alarm will be sent by the device at the other end of the span. One alarm will have “(source)” to indicate that it came from the source end point, and the other will have “(sink)” to indicate that it came from the sink end point.</p>
18058/ 18059	SPAN Degraded – RED Fault Daily Threshold Exceeded (source)/(sink)	<p>This alarm indicates that the number of RED faults exceeded the alarm threshold (default threshold = 16) within a 24-hour period. A RED Alarm Event is generated when there is a Loss of Signal, Loss of Frame Alignment or the Bit Error Rate <math>\leq 10E-3</math>. This alarm is caused by the receive span fading in and out. This alarm condition will have an insignificant impact on system performance and call quality. This alarm may provide an early warning of a more serious condition. This alarm will be sent by one of the two devices at the end of the span.</p> <p>In some cases, a second alarm will be sent by the device at the other end of the span. One alarm will have “(source)” to indicate that it came from the source end point, and the other will have “(sink)” to indicate that it came from the sink end point.</p>
18061/ 18062	SPAN Degraded – RED Fault Hourly Threshold Exceeded (source)/(sink)	<p>This alarm indicates that the number of RED alarms exceeded the alarm threshold (default threshold = 20) within a 1-hour period. A RED Alarm Event is generated when there is a Loss of Signal, Loss of Frame Alignment or the Bit Error Rate <math>\leq 10E-3</math>. This alarm condition may have a minor impact on system performance and call quality. This alarm may provide an early warning of a more serious condition. This alarm will be sent by one of the two devices at the end of the span.</p> <p>In some cases, a second alarm will be sent by the device at the other end of the span. One alarm will have “(source)” to indicate that it came from the source end point, and the other will have “(sink)” to indicate that it came from the sink end point.</p>
18064/ 18065	SPAN Degraded – RED Fault Critical Threshold Exceeded (source)/(sink)	<p>This alarm indicates that the number of RED alarms exceeded the alarm threshold (default threshold = 511) within a 24-hour period. A RED Alarm Event is generated when there is a Loss of Signal, Loss of Frame Alignment or the Bit Error Rate <math>\leq 10E-3</math>. This alarm indicates that system performance and call quality is seriously degraded. This alarm will be sent by one of the two devices at the end of the span.</p> <p>In some cases, a second alarm will be sent by the device at the other end of the span. One alarm will have “(source)” to indicate that it came from the source end point, and the other will have “(sink)” to indicate that it came from the sink end point.</p>



**Table B-1:** List of Alarms (Software Release 15)

Alarm #	Alarm Name	Alarm Description
18067/ 18068	SPAN Out-of-Service – Continuous RED Faults (source)/(sink)	<p>This alarm indicates that the span is out-of-service due to continuous RED faults being received for more than 2.5 seconds. A RED Alarm Event is generated when there is a Loss of Signal, Loss of Frame Alignment or the Bit Error Rate <math>\geq 10E-3</math>. This alarm indicates that the receive span signal was lost, the receive framing words were corrupted, or an incompatible remote span interface was detected by the network. This alarm will be sent by one of the two devices at the end of the span.</p> <p>In some cases, a second alarm will be sent by the device at the other end of the span. One alarm will have “(source)” to indicate that it came from the source end point, and the other will have “(sink)” to indicate that it came from the sink end point.</p>
18070/ 18071	SPAN Degraded – Sync Loss Daily Threshold Exceeded (source)/(sink)	<p>The alarm indicates that the count of synch loss alarms has exceeded the alarm threshold (default threshold = 16) within a 24 hour period. This alarm condition will have an insignificant impact on system performance and call quality. This alarm may provide an early warning of a more serious condition. This alarm will be sent by one of the two devices at the end of the span.</p> <p>In some cases, a second alarm will be sent by the device at the other end of the span. One alarm will have “(source)” to indicate that it came from the source end point, and the other will have “(sink)” to indicate that it came from the sink end point.</p>
18073/ 18074	SPAN Degraded – Sync Loss Hourly Threshold Exceeded (source)/(sink)	<p>The alarm indicates that the count of synch loss alarms has exceeded the alarm threshold (default threshold = 20) within a 1 hour period. This alarm condition may have a minor impact on system performance and call quality. This alarm may provide an early warning of a more serious condition. This alarm will be sent by one of the two devices at the end of the span.</p> <p>In some cases, a second alarm will be sent by the device at the other end of the span. One alarm will have “(source)” to indicate that it came from the source end point, and the other will have “(sink)” to indicate that it came from the sink end point.</p>
18076/ 18077	SPAN Degraded – Sync Loss Critical Threshold Exceeded (source)/(sink)	<p>The alarm indicates that the count of synch loss alarms has exceeded the alarm threshold (default threshold = 511) within a 24 hour period. This alarm indicates that system performance and call quality is seriously degraded. This alarm will be sent by one of the two devices at the end of the span.</p> <p>In some cases, a second alarm will be sent by the device at the other end of the span. One alarm will have “(source)” to indicate that it came from the source end point, and the other will have “(sink)” to indicate that it came from the sink end point.</p>



**B**

**Table B-1:** List of Alarms (Software Release 15)

Alarm #	Alarm Name	Alarm Description
18079/ 18080	SPAN Degraded – BER Daily Threshold Exceeded (source)/(sink)	<p>This error indicates that the Bit Error Rate (BER) has risen above the alarm threshold (default threshold = 10E–6). This alarm condition will have an insignificant impact on system performance and call quality. This alarm may provide an early warning of a more serious condition. This alarm will be sent by one of the two devices at the end of the span.</p> <p>In some cases, a second alarm will be sent by the device at the other end of the span. One alarm will have “(source)” to indicate that it came from the source end point, and the other will have “(sink)” to indicate that it came from the sink end point.</p>
18082/ 18083	SPAN Degraded – BER Hourly Threshold Exceeded (source)/(sink)	<p>This error indicates that the Bit Error Rate (BER) has risen above the alarm threshold (default threshold = 10E–4). This alarm condition may have a minor impact on system performance and call quality. This alarm may provide an early warning of a more serious condition. This alarm will be sent by one of the two devices at the end of the span.</p> <p>In some cases, a second alarm will be sent by the device at the other end of the span. One alarm will have “(source)” to indicate that it came from the source end point, and the other will have “(sink)” to indicate that it came from the sink end point.</p>
18085/ 18086	SPAN Degraded – BER Critical Threshold Exceeded (source)/(sink)	<p>This error indicates that the Bit Error Rate (BER) has risen above the alarm threshold (default threshold = 10E–3). This alarm indicates that system performance and call quality is seriously degraded. This alarm will be sent by one of the two devices at the end of the span.</p> <p>In some cases, a second alarm will be sent by the device at the other end of the span. One alarm will have “(source)” to indicate that it came from the source end point, and the other will have “(sink)” to indicate that it came from the sink end point.</p>
18090	Span Type Mismatch	<p>This error indicates that the span type configuration downloaded from the OMC–R is not the same as the type programmed into the BTSs in the modem cage where the span terminates. The span is operational while the alarm is present but may prevent a span from returning to service if a BTS fails or goes out of service for any reason.</p>
18091/ 18092	SPAN Out-of-Service – Continuous Sync Loss (source)/(sink)	<p>This alarm indicates that the span is out-of-service due to continuous sync loss faults being detected. This alarm indicates that the receive span signal was lost, the receive framing words were corrupted, or an in-compatible remote span interface was detected by the network. This alarm will be sent by one of the two devices at the end of the span.</p> <p>In some cases, a second alarm will be sent by the device at the other end of the span. One alarm will have “(source)” to indicate that it came from the source end point, and the other will have “(sink)” to indicate that it came from the sink end point.</p>