

Test Equipment Preparation – continued

HP8921A System Connectivity Test

Follow the steps outlined in Table F-3 to verify that the connections between the PCS Interface and the HP8921A are correct and cables are intact. The software also performs basic functionality checks of each instrument.



IMPORTANT

Disconnect other GPIB devices, especially system controllers, from the system before running the connectivity software.

Table F-3: System Connectivity

Step	Action
	* IMPORTANT – Perform this procedure <i>after</i> test equipment has been allowed to warm-up and stabilize for a <i>minimum of 60 minutes</i> .
1	Insert HP 83236A Manual Control/System card into memory card slot.
2	Press the [PRESET] pushbutton.
3	Press the Screen Control [TESTS] pushbutton to display the “Tests” Main Menu screen.
4	Position the cursor at Select Procedure Location and select it by pressing the cursor control knob. In the Choices selection box, select Card .
5	Position the cursor at Select Procedure Filename and select it by pressing the cursor control knob. In the Choices selection box, select SYS_CONN .
6	Position the cursor at RUN TEST and select it. The software will prompt you through the connectivity setup.
7	Do the following when the test is complete, <ul style="list-style-type: none">• position cursor on STOP TEST and select it• OR press the [K5] pushbutton.
8	To return to the main menu, press the [K5] pushbutton.
9	Press the [PRESET] pushbutton.

Test Equipment Preparation – continued

Setting HP8921A and HP83236A/B GPIB Address

Table F-4: Setting HP8921A GPIB Address

Step	Action
1	If you have not already done so, turn the HP8921A power on.
2	Verify that the GPIB addresses are set correctly. <ul style="list-style-type: none">• HP8921A HP-IB Adrs = 18, accessed by pushing LOCAL and selecting More and I/O Configure on the HP8921A/600. (Consult test equipment OEM documentation for additional info as required).• HP83236A (or B) PCS Interface GPIB address=19. Set dip switches as follows:<ul style="list-style-type: none">– A1=1, A2=1, A3=0, A4=0, A5=1, HP-IB/Ser = 1

Pretest Setup for HP8921A

Before the HP8921A CDMA analyzer is used for LMF controlled testing it must be set up correctly for automatic testing.

Table F-5: Pretest Setup for HP8921A

Step	Action
1	Unplug the memory card if it is plugged in.
2	Press the CURSOR CONTROL knob.
3	Position the cursor at IO CONFIG (under To Screen and More) and select it.
4	Select Mode and set for Talk&Lstn .

Pretest Setup for HP8935

Before the HP8935 CDMA analyzer is used for LMF controlled testing it must be set up correctly for automatic testing.

Table F-6: Pretest Setup for HP8935

Step	Action
1	Unplug the memory card if it is plugged in.
2	Press the Shift button and then press the I/O Config button.
3	Press the Push to Select knob.
4	Position the cursor at IO CONFIG and select it.
5	Select Mode and set for Talk&Lstn .

Advantest R3465 Connection

The following diagram depicts the rear panels of the Advantest test equipment as configured to perform automatic tests. All test equipment is controlled by the LMF via an IEEE-488/GPIB bus. The LMF expects each piece of test equipment to have a factory-set GPIB address (refer to Table F-7). If there is a communications problem between the LMF and any piece of test equipment, you should verify that the GPIB addresses have been set correctly and that the GPIB cables are firmly connected to the test equipment.

Figure F-3 shows the connections when **not using** an external 10 MHz Rubidium reference.

Figure F-3: Cable Connections for Test Set without 10 MHz Rubidium Reference

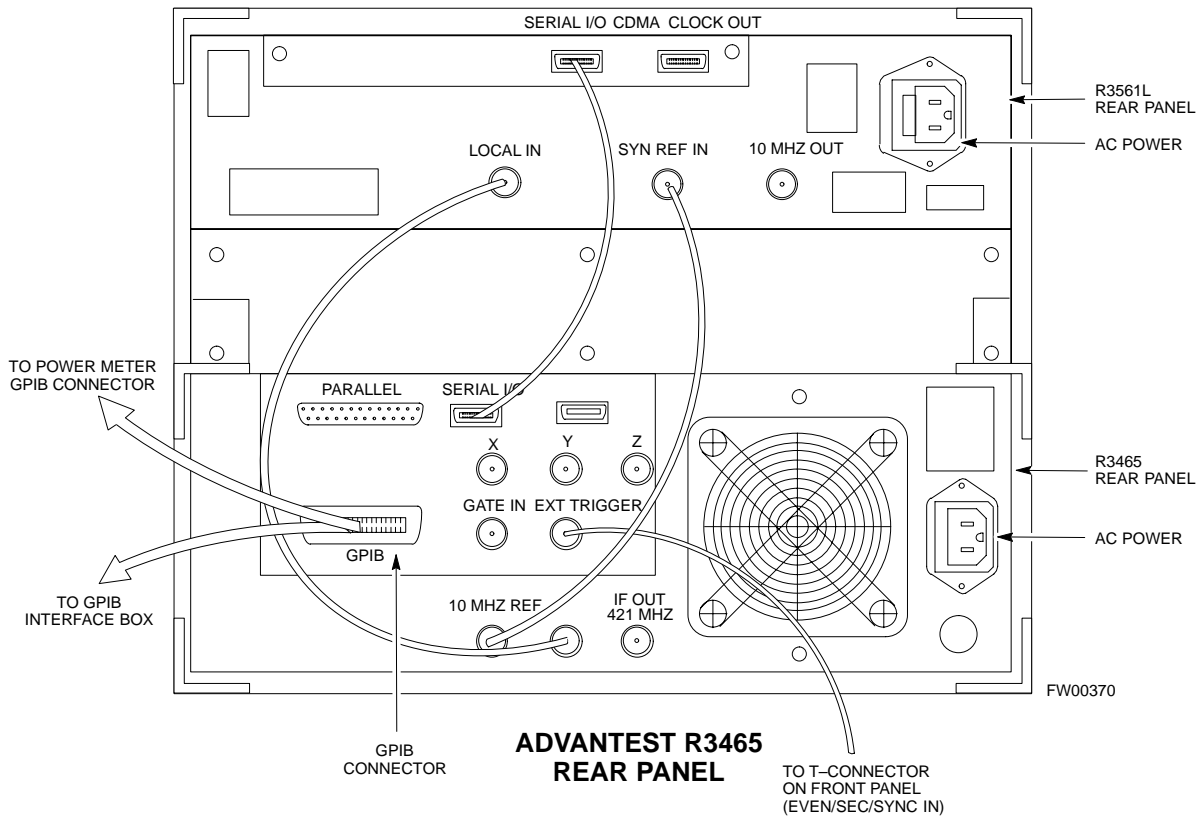

F

Test Equipment Preparation – continued

Figure F-4 shows the connections when **using** an external 10 MHz Rubidium reference.

Figure F-4: Cable Connections for Test Set with 10 MHz Rubidium Reference

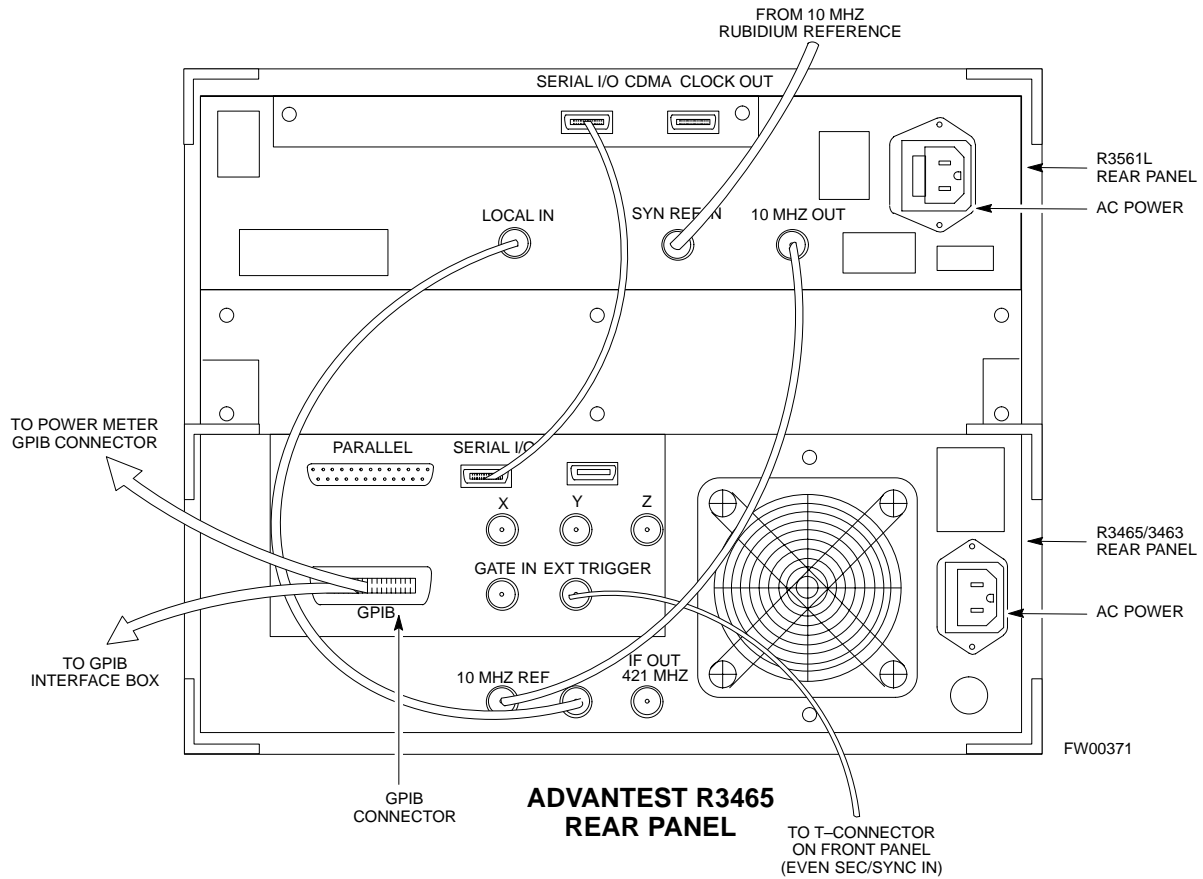

F

Test Equipment Preparation – continued

R3465 GPIB Address & Clock setup

Table F-7 describes the steps to set the GPIB address and clock for the **Advantest** R3465 equipment.

Table F-7: Advantest R3465 GPIB Address and Clock Setup	
Step	Action
1	<p>Communications test set GPIB address=18 (<i>perform the following to view/set as required</i>) Perform the following to set the standard parameters on the test set:</p> <ul style="list-style-type: none"> • Push the SHIFT then PRESET pushbutton (just below the CRT display). • Push the LCL pushbutton (CW in Measurement just below the CRT display) <ul style="list-style-type: none"> – Push the GPIB and Others CRT menu key to view the current address. – <i>If required</i>, change GPIB address to 18 (<i>rotate the vernier knob to set, push the vernier knob to enter</i>)
2	<p>Verify the current Date and Time in upper/right of the CRT display (<i>perform the following to set if required</i>) Communications test set GPIB address=18 (<i>perform the following to view/set as required</i>)</p> <ul style="list-style-type: none"> • Push the Date/Time CRT menu key • <i>If required</i>, change to correct Date/Time (<i>rotate the vernier knob to select and set, push the vernier knob to enter</i>) • Push the SHIFT then PRESET pushbutton (just below the CRT display).

Pretest Setup for Advantest R3465

Before the Advantest R3465 analyzer is used for LMF controlled testing it must be set up correctly for automatic testing.

Table F-8: Pretest Setup for Advantest R346	
Step	Action
1	Press the SHIFT button so the LED next to it is illuminated.
2	Press the RESET button.



Calibrating HP437 Power Meter

Precise transmit output power calibration measurements are made using a bolometer-type broadband power meter with a sensitive power sensor. Follow the steps outlined in Table F-9 to enter information unique to the power sensor before calibrating the test setup. Refer to Figure F-5 as required.



IMPORTANT

This procedure must be done *in conjunction with* the automated calibration to enter power sensor specific calibration values.

Figure F-5: Power Meter Detail

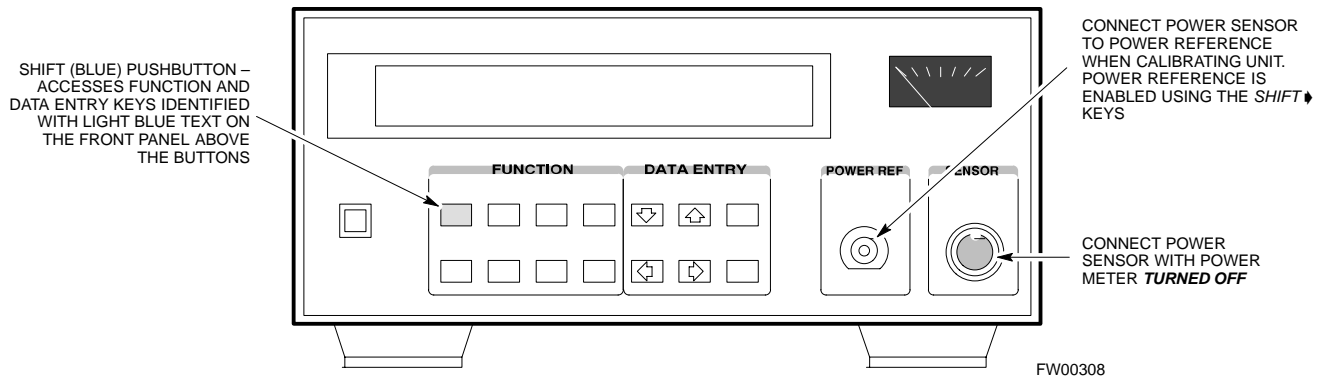

Table F-9: Power Meter Calibration Procedure

Step	Action
	<p>! CAUTION</p> <p>Do not connect/disconnect the power meter sensor cable with ac power applied to the meter. Disconnection could result in destruction of the sensing element or mis-calibration.</p>
1	<ul style="list-style-type: none"> – Make sure the power meter AC LINE pushbutton is OFF. – Connect the power sensor cable to the SENSOR input.
2	<p>Set the AC LINE pushbutton to ON.</p> <p>NOTE</p> <p>The calibration should be performed only after the power meter and sensor have been allowed to warm-up and stabilize for a <i>minimum of 60 minutes</i>.</p>
3	<p>Perform the following to set or verify the GPIB address:</p> <ul style="list-style-type: none"> – To enter the SPECIAL data entry function, press [SHIFT] then [PRESET]. – Use the [▲] or [▼] button to select HP-IB ADRS; then press [ENTER]. – Use the [▲] or [▼] button to select HP-IB ADRS 13; then press [ENTER]. – To EXIT the SPECIAL data entry function press [SHIFT] then [ENTER].

... continued on next page

Test Equipment Preparation – continued

Table F-9: Power Meter Calibration Procedure

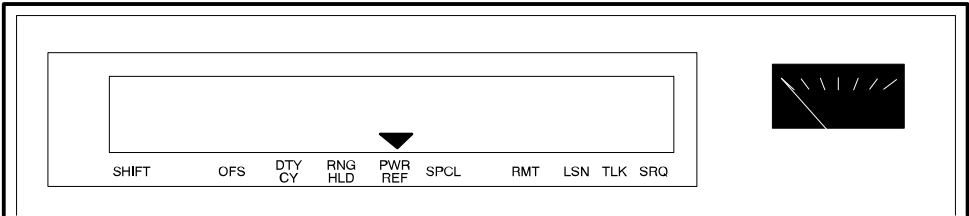
Step	Action
4	<p>Perform the following to set or verify the correct power sensor model:</p> <ul style="list-style-type: none"> – Press [SHIFT] then [↵] to select SENSOR. – Identify the power sensor model number from the sensor label. Use the [▲] or [▼] button to select the appropriate model; then press [ENTER]. <p>NOTE Be sure the PWR REF (power reference) output is OFF (observe that the triangular indicator is NOT displayed as shown in Step 7). If on, press [SHIFT] then [↵] to turn it off.</p>
5	Press [ZERO] . Display will show “Zeroing *****.” Wait for process to complete.
6	Connect the power sensor to the POWER REF output.
7	<p>To turn on the PWR REF, perform the following:</p> <ul style="list-style-type: none"> – Press [SHIFT] then [↵]. – Verify that the triangular indicator (below) appears in the display above “PWR REF”. <div style="text-align: center;">  </div>
8	<p>Perform the following to set the REF CF %:</p> <ul style="list-style-type: none"> – Press ([SHIFT] then [ZERO]) for CAL. – Enter the sensor’s REF CF % from the sensor’s decal using the arrow keys and press [ENTER]. (The power meter will display “CAL *****” for a few seconds.) <p>NOTE If the REF CAL FACTOR (REF CF) is not shown on the power sensor, assume it to be 100%.</p>
9	<p>Perform the following to set the CAL FAC %:</p> <ul style="list-style-type: none"> – Press [SHIFT] then [FREQ] for CAL FAC. – On the sensor’s decal, locate an approximate calibration percentage factor (CF%) at 2 GHz. Enter the sensor’s calibration % (CF%) using the arrow keys and press [ENTER]. <p>When complete, the power meter will typically display 0.05 dBm. (Any reading between 0.00 and 0.10 is normal.)</p>
10	<p>To turn off the PWR REF, perform the following:</p> <ul style="list-style-type: none"> – Press [SHIFT] then [↵]. – Disconnect the power sensor from the POWER REF output.

■
F
■

Test Equipment Preparation – continued

Calibrating Gigatronics 8542 power meter

Precise transmit output power calibration measurements are made using a bolometer-type broadband power meter with a sensitive power sensor. Follow the steps in Table F-10 to enter information unique to the power sensor.

Table F-10: Calibrate Gigatronics 8542 Power Meter

Step	Action
	<p>! CAUTION Do not connect/disconnect the power meter sensor cable with AC power applied to the meter. Disconnection could result in destruction of the sensing element or miscalibration.</p>
	<p>NOTE Allow the power meter and sensor to warm up and stabilize for a <i>minimum of 60 minutes</i> before performing the calibration procedure.</p>
1	<ul style="list-style-type: none"> • Make sure the power meter POWER pushbutton is OFF. • Connect the power sensor cable to the SENSOR input. • Set the POWER pushbutton to ON.
2	<p>Verify the Power GPIB mode and address:</p> <ul style="list-style-type: none"> • Press MENU. Use the ↵ arrow key to select CONFIG MENU, and press ENTER. • Use the ↵ arrow key to select GPIB, and press ENTER. • Use the ↵↶ arrow keys as required to set MODE to 8541C or 8542C (as appropriate). • Press ▶ and use the ↵↶ arrow keys as required to set ADDRESS to 13. • Press ENTER.
3	<ul style="list-style-type: none"> • Connect the power sensor to the CALIBRATOR output connector. • Press ZERO. • Wait for the process to complete. Sensor factory calibration data is read to power meter during this process. • Disconnect the power sensor from the CALIBRATOR output.

F

Test Equipment Preparation – continued

Figure F-6: Gigatronics 8542C Power Meter Detail

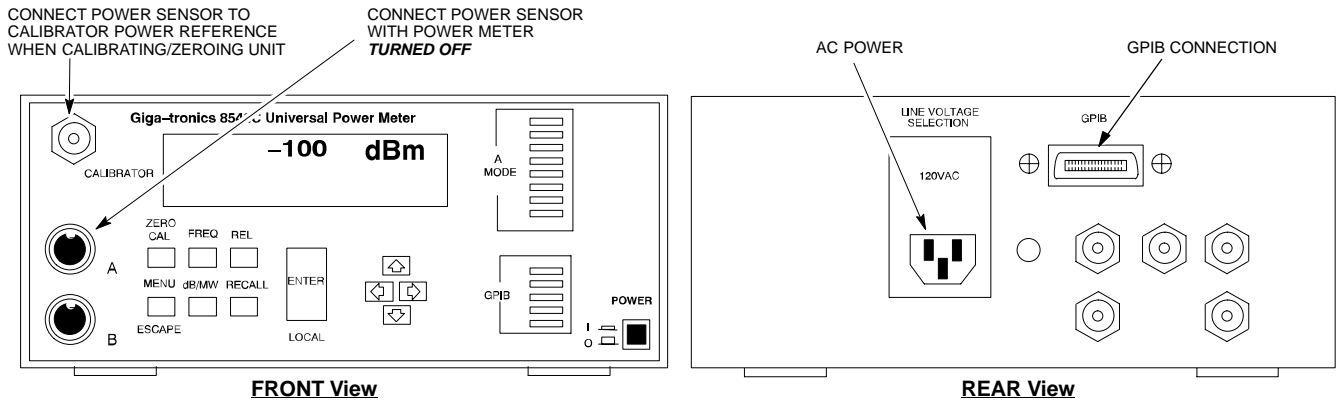

FW00564

F

Manual Cable Calibration

Calibrating Test Cable Setup using HP PCS Interface (HP83236)

Table F-11 covers the procedure to calibrate the test equipment using the HP8921 Cellular Communications Analyzer equipped with the HP83236 PCS Interface.

NOTE

This calibration method *must be executed with great care*. Some losses are measured close to the minimum limit of the power meter sensor (−30 dBm).

Prerequisites

Ensure the following prerequisites have been met before proceeding:

- Test equipment to be calibrated has been connected correctly for cable calibration.
- Test equipment has been selected and calibrated.

Table F-11: Calibrating Test Cable Setup (using the HP PCS Interface)

Step	Action		
	NOTE Verify that GPIB controller is turned off.		
1	Insert HP83236 Manual Control System card into memory card slot.		
2	Press the Preset pushbutton.		
3	Under Screen Controls , press the TESTS pushbutton to display the TESTS (Main Menu) screen.		
4	Position the cursor at Select Procedure Location and select it. In the Choices selection box, select CARD .		
5	Position the cursor at Select Procedure Filename and select it. In the Choices selection box, select MANUAL .		
6	Position the cursor at RUN TEST and select it. HP must be in Control Mode Select YES .		
7	<table border="0"> <tr> <td style="vertical-align: top;"> <p>If using HP83236A: Set channel number=<chan#>:</p> <ul style="list-style-type: none"> – Position cursor at Channel Number and select it. – Enter the <i>chan#</i> using the numeric keypad; press [Enter] and the screen will go blank. – When the screen reappears, the <i>chan#</i> will be displayed on the channel number line. </td> <td style="vertical-align: top;"> <p>If using HP83236B: Set channel frequency:</p> <ul style="list-style-type: none"> – Position cursor at Frequency Band and press Enter. – Select User Defined Frequency. – Go Back to Previous Menu. – Position the cursor to 83236 generator frequency and enter actual RX frequency. – Position the cursor to 83236 analyzer frequency and enter actual TX frequency. </td> </tr> </table>	<p>If using HP83236A: Set channel number=<chan#>:</p> <ul style="list-style-type: none"> – Position cursor at Channel Number and select it. – Enter the <i>chan#</i> using the numeric keypad; press [Enter] and the screen will go blank. – When the screen reappears, the <i>chan#</i> will be displayed on the channel number line. 	<p>If using HP83236B: Set channel frequency:</p> <ul style="list-style-type: none"> – Position cursor at Frequency Band and press Enter. – Select User Defined Frequency. – Go Back to Previous Menu. – Position the cursor to 83236 generator frequency and enter actual RX frequency. – Position the cursor to 83236 analyzer frequency and enter actual TX frequency.
<p>If using HP83236A: Set channel number=<chan#>:</p> <ul style="list-style-type: none"> – Position cursor at Channel Number and select it. – Enter the <i>chan#</i> using the numeric keypad; press [Enter] and the screen will go blank. – When the screen reappears, the <i>chan#</i> will be displayed on the channel number line. 	<p>If using HP83236B: Set channel frequency:</p> <ul style="list-style-type: none"> – Position cursor at Frequency Band and press Enter. – Select User Defined Frequency. – Go Back to Previous Menu. – Position the cursor to 83236 generator frequency and enter actual RX frequency. – Position the cursor to 83236 analyzer frequency and enter actual TX frequency. 		

. . . continued on next page

Manual Test Cable Setup – continued

Table F-11: Calibrating Test Cable Setup (using the HP PCS Interface)

Step	Action									
8	Set RF Generator level: <ul style="list-style-type: none"> – Position the cursor at RF Generator Level and select it. – Enter -10 using the numeric keypad; press [Enter] and the screen will go blank. – When the screen reappears, the value -10 dBm will be displayed on the RF Generator Level line. 									
9	Set the user fixed Attenuation Setting to 0 dBm : <ul style="list-style-type: none"> – Position cursor at Analyzer Attenuation and select it – Position cursor at User Fixed Atten Settings and select it. – Enter 0 (zero) using the numeric keypad and press [Enter]. 									
10	Select Back to Previous Menu .									
11	Record the HP83236 Generator Frequency Level: Record the HP83236B Generator Frequency Level: <ul style="list-style-type: none"> – Position cursor at Show Frequency and Level Details and select it. – Under HP83236 Frequencies and Levels, record the Generator Level. – Under HP83236B Frequencies and Levels, record the Generator Frequency Level (1850 – 1910 MHz). – Position cursor at Prev Menu and select it. 									
12	Click on Pause for Manual Measurement .									
13	Connect the power sensor directly to the <i>RF OUT ONLY</i> port of the PCS Interface.									
14	On the HP8921A, under To Screen , select CDMA GEN .									
15	Move the cursor to the Amplitude field and click on the Amplitude value.									
16	Increase the Amplitude value until the power meter reads 0 dBm ±0.2 dB . NOTE The Amplitude value can be increased coarsely until 0 dBm is reached; then fine tune the amplitude by adjusting the Increment Set to 0.1 dBm and targeting in on 0 dBm.									
17	Disconnect the power sensor from the <i>RF OUT ONLY</i> port of the PCS Interface. * IMPORTANT The Power Meter sensor's lower limit is -30 dBm. Thus, only components having losses ≤30 dB should be measured using this method. For further accuracy, always re-zero the power meter before connecting the power sensor to the component being calibrated. After connecting the power sensor to the component, record the calibrated loss immediately.									
18	Disconnect all components in the test setup and calibrate each one separately by connecting each component, one-at-a-time, between the <i>RF OUT ONLY PORT</i> and the power sensor. Record the calibrated loss value displayed on the power meter. <ul style="list-style-type: none"> • Example: <table style="margin-left: 20px; border: none;"> <tr> <td>(A) Test Cable(s)</td> <td>=</td> <td>-1.4 dB</td> </tr> <tr> <td>(B) 20 dB Attenuator</td> <td>=</td> <td>-20.1 dB</td> </tr> <tr> <td>(B) Directional Coupler</td> <td>=</td> <td>-29.8 dB</td> </tr> </table> 	(A) Test Cable(s)	=	-1.4 dB	(B) 20 dB Attenuator	=	-20.1 dB	(B) Directional Coupler	=	-29.8 dB
(A) Test Cable(s)	=	-1.4 dB								
(B) 20 dB Attenuator	=	-20.1 dB								
(B) Directional Coupler	=	-29.8 dB								

... continued on next page



Manual Test Cable Setup – continued

Table F-11: Calibrating Test Cable Setup (using the HP PCS Interface)

Step	Action
19	After all components are calibrated, reassemble all components together and calculate the total test setup loss by adding up all the individual losses: <ul style="list-style-type: none"> • Example: Total test setup loss = $-1.4 -29.8 -20.1 = -51.3$ dB. This calculated value will be used in the next series of tests.
20	Under Screen Controls press the TESTS button to display the TESTS (Main Menu) screen.
21	Select Continue (K2) .
22	Select RF Generator Level and set to -119 dBm.
23	Click on Pause for Manual Measurement .
24	Verify the HP8921A Communication Analyzer/83203A CDMA interface setup is as follows (fields not indicated remain at default): <ul style="list-style-type: none"> • Verify the GPIB (HP-IB) address: <ul style="list-style-type: none"> – under To Screen, select More – select IO CONFIG – Set HP-IB Adrs to 18 – set Mode to Talk&Lstn • Verify the HP8921A is displaying frequency (instead of RF channel) <ul style="list-style-type: none"> – Press the blue [SHIFT] button, then press the Screen Control [DUPLEX] button; this switches to the CONFIG (CONFIGURE) screen. – Use the cursor control to set RF Display to Freq
25	Refer to Chapter 3 for assistance in setting the cable loss values into the LMF.

F

Manual Test Cable Setup – continued

Figure F-7: Cable Calibration Using HP8921 with PCS Interface

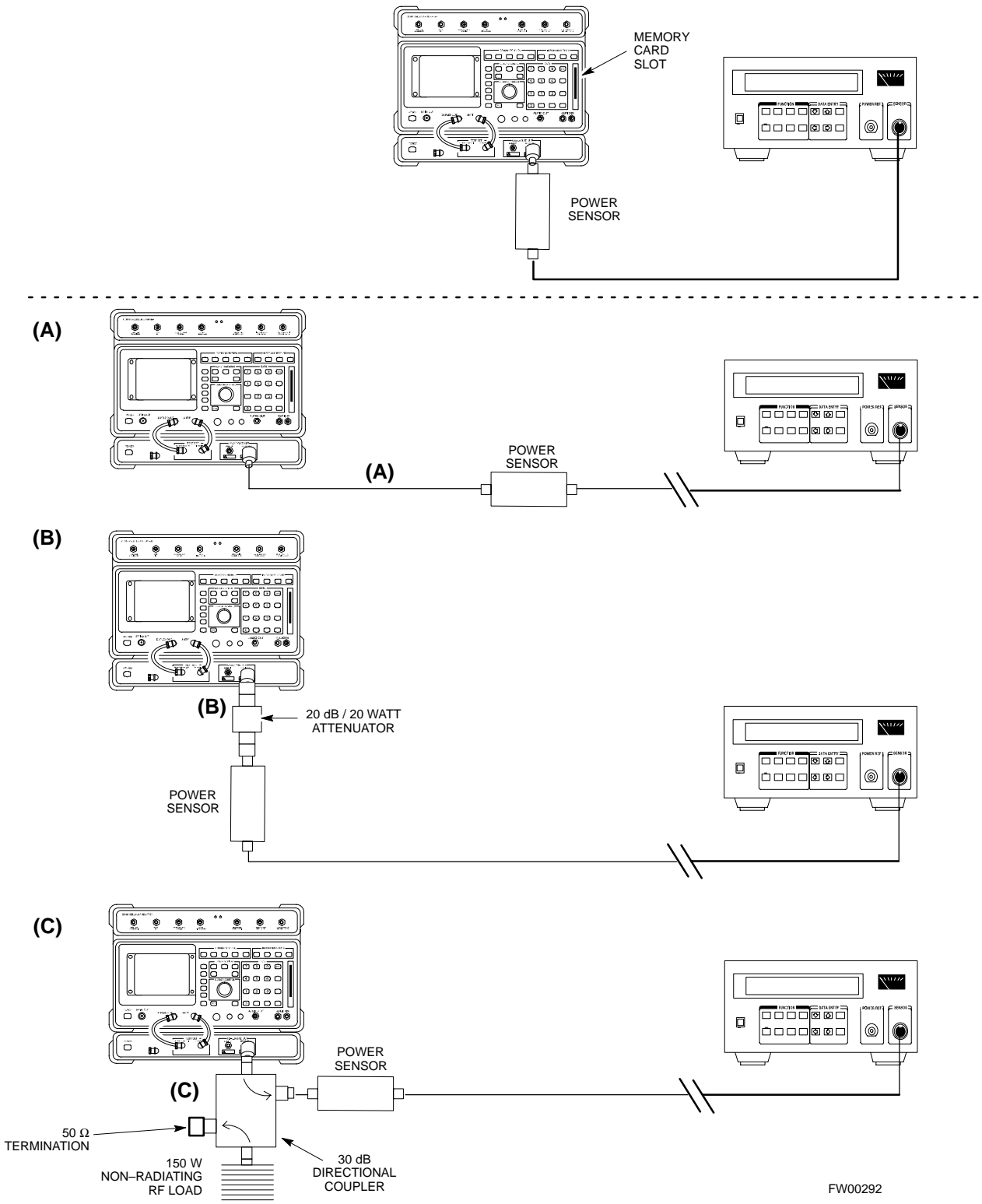

F

Manual Test Cable Setup – continued

Calibrating Test Cable Setup using Advantest R3465

NOTE

Be sure the GPIB Interface is OFF for this procedure.

Advantest R3465 Manual Test setup and calibration must be performed at both the TX and RX frequencies.

Table F-12: Procedure for Calibrating Test Cable Setup Using Advantest R3465

Step	Action
	<p>* IMPORTANT</p> <p>– This procedure can only be performed <i>after</i> test equipment has been allowed to warm-up and stabilize for a <i>minimum of 60 minutes</i>.</p>
1	Press the SHIFT and the PRESET keys located below the display
2	Press the ADVANCE key in the MEASUREMENT area of the control panel.
3	Select the CDMA Sig CRT menu key
4	Select the Setup CRT menu key
5	Using the vernier knob and the cursor keys set the following parameters
	<p>NOTE</p> <p>Fields not listed remain at default</p> <p>Generator Mode: SIGNAL</p> <p>Link: FORWARD</p> <p>Level Unit: dBm</p> <p>CalCorrection: ON</p> <p>Level Offset: OFF</p>
6	Select the return CRT menu key
7	Press FREQ key in the ENTRY area
8	Set the frequency to the desired value using the keypad entry keys
9	Verify that the Mod CRT menu key is highlighting OFF; if not, press the Mod key to toggle it OFF.
10	Verify that the Output CRT menu key is highlighting OFF; if not, press the Output key to toggle it OFF.
11	Press the LEVEL key in the ENTRY area.
12	Set the LEVEL to 0 dBm using the key pad entry keys.
13	Zero power meter. Next connect the power sensor directly to the “RF OUT” port on the R3561L CDMA Test Source Unit.
14	Press the Output CRT menu key to toggle Output to ON.
15	Record the power meter reading _____

... continued on next page

Manual Test Cable Setup – continued

Table F-12: Procedure for Calibrating Test Cable Setup Using Advantest R3465

Step	Action								
16	<p>Disconnect the power meter sensor from the R3561L RF OUT jack.</p> <p>* IMPORTANT The Power Meter sensor's lower limit is -30 dBm. Thus, only components having losses ≤ 30 dB should be measured using this method. For best accuracy, always re-zero the power meter before connecting the power sensor to the component being calibrated. Then, after connecting the power sensor to the component, record the calibrated loss immediately.</p>								
17	<p>Disconnect all components in the the test setup and calibrate each one separately. Connect each component one-at-a-time between the "RF OUT" port and the power sensor (see Figure F-8, "Setups A, B, and C"). Record the calibrated loss value displayed on the power meter for each connection.</p> <p>Example:</p> <table border="0" style="margin-left: 20px;"> <tr> <td>(A) 1st Test Cable</td> <td>= -0.5 dB</td> </tr> <tr> <td>(B) 2nd Test Cable</td> <td>= -1.4 dB</td> </tr> <tr> <td>(C) 20 dB Attenuator</td> <td>= -20.1 dB</td> </tr> <tr> <td>(D) 30 dB Directional Coupler</td> <td>= -29.8 dB</td> </tr> </table>	(A) 1st Test Cable	= -0.5 dB	(B) 2nd Test Cable	= -1.4 dB	(C) 20 dB Attenuator	= -20.1 dB	(D) 30 dB Directional Coupler	= -29.8 dB
(A) 1st Test Cable	= -0.5 dB								
(B) 2nd Test Cable	= -1.4 dB								
(C) 20 dB Attenuator	= -20.1 dB								
(D) 30 dB Directional Coupler	= -29.8 dB								
18	<p>Press the Output CRT menu key to toggle Output OFF.</p>								
19	<p>Calculate the total test setup loss by adding up all the individual losses:</p> <p>Example: Total test setup loss = $0.5 + 1.4 + 20.1 + 29.8 = 51.8$ dB</p> <p>This calculated value will be used in the next series of tests.</p>								
20	<p>Press the FREQ key in the ENTRY area</p>								
21	<p>Using the keypad entry keys, set the test frequency to the RX frequency</p>								
22	<p>Repeat steps 9 through 19 for the RX frequency.</p>								
23	<p>Refer to Chapter 3 for assistance in setting the cable loss values into the LMF.</p>								



Manual Test Cable Setup – continued

Figure F-8: Cable Calibration Using Advantest R3465

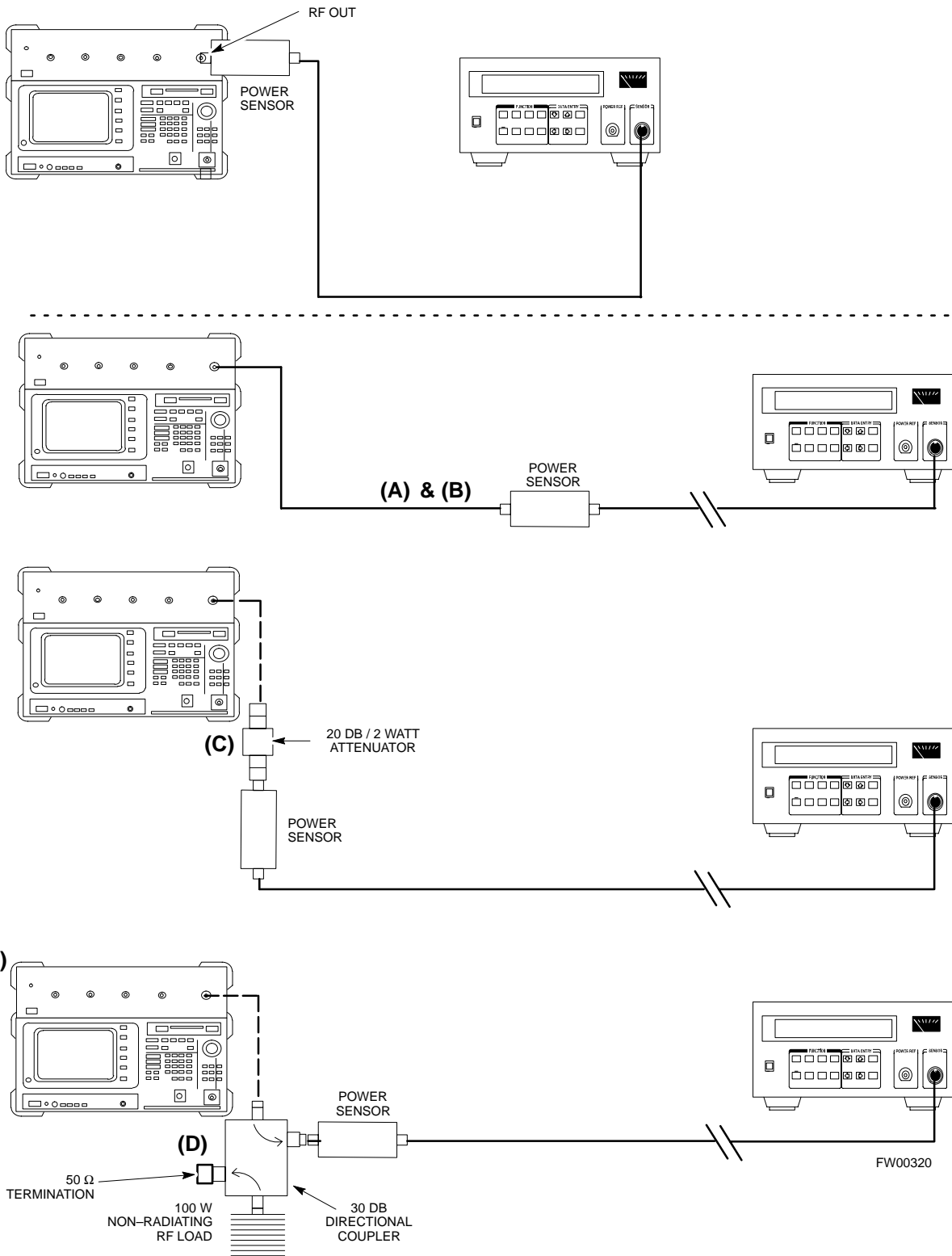

F

Appendix G: Download ROM Code

Appendix Content

Downloading ROM Code with the LMF	G-1
Exception Procedure – Downloading Device ROM Code	G-1



Downloading ROM Code with the LMF

Exception Procedure – Downloading Device ROM Code

This procedure is not part of a normal optimization.

Perform this procedure only on an exception basis when no alternative exists to load a BTS device with the correct version of ROM code.

NOTE

An MGLI or GLI must be INS (green) before ROM code can be downloaded to non-GLI devices.



CAUTION

Release 2.9.x RAM code must NOT be downloaded to a device loaded with Release 2.8.x ROM code, and Release 2.8.x RAM code must NOT be downloaded to a device loaded with Release 2.9.x ROM code.

All devices in a BTS must have the same Release-level ROM and RAM code before the optimization and ATP procedures can be performed.

If a newly-installed Release 8-equipped BTS is to be upgraded to Release 2.9.x, the optimization and Acceptance Test Procedures (ATP) should be accomplished with the Release 2.8.x code and software. Following the optimization, the site code and software should be upgraded to Release 2.9.x by the CBSC. It is not necessary to perform the optimization and ATPs again after the upgrade.

If a replacement device with Release 2.8.x ROM code must be used in a Release 2.9.x-equipped BTS, the device ROM code can be changed using the CDMA LMF before the performing the BTS optimization and ATPs. *A device loaded with Release 2.9.x ROM code can not be converted back to Release 2.8.x ROM code in the field without Motorola assistance.*

If it is necessary to download ROM code to a device from the CDMA LMF, the procedure in Table G-1 includes steps *for both ROM and RAM code download* using the CDMA LMF.

Prerequisites

Prior to performing this procedure, ensure the correct ROM and RAM code files exist on the CDMA LMF for each of the devices to be loaded.



CAUTION

The Release level of the ROM code to be downloaded must be the same as the Release level of the ROM code resident in the other devices in the BTS. Release 2.9.x ROM code must not be downloaded to a frame having Release 2.8.x code, and Release 2.8.x code must not be downloaded to a frame having Release 2.9.x code.

This procedure should only be used to upgrade replacement devices for a BTS. It should NOT be used to upgrade all devices in a BTS. If a BTS is to be upgraded from Release 2.8.x to Release 2.9.x, optimization and ATP must first be performed with the BTS in a Release 2.8.x configuration. Following this, the upgrade from Release 2.8.x to Release 2.9.x should be done by the CBSC.

Table G-1: Download ROM and RAM Code to Devices

Step	Action
1	Click on the device to be loaded.
2	From the Device pull down menu, select Status . A status report window will appear
3	Make a note of the number in the HW Bin Type column. NOTE “HW Bin Type” is the Hardware Binary Type for the device. This number is used as the last four digits in the filename of a device’s binary ROM code file. Using this part of the filename, the ROM code file can be matched to the device in which it is to be loaded.
4	Click OK to close the status window.
5	Click on the device to be loaded.
6	* IMPORTANT The CDMA LMF will not automatically select ROM code files for download. ROM code files must be selected <i>manually</i> . From the Device pull down menu, select Download Code Manual . A file selection window will appear.
7	Double-click on the version folder with the desired version number for the ROM code file.
8	Double-click the Code folder. A list of ROM and RAM code files will be displayed.

. . . continued on next page

F

Downloading ROM Code with the LMF – continued

Table G-1: Download ROM and RAM Code to Devices

Step	Action
9	<p>! CAUTION A ROM code file with the correct hardware binary type (HW Bin Type) must be chosen. Using a file with the wrong HW Bin Type can result in unpredictable operation and damage to the device.</p> <p>Click on the ROM code file with the filename which matches the device type and HW Bin Type number noted in step 3 (e.g., file bbx_rom.bin.0604 is the ROM code file for a BBX with a HW Bin Type of 0604). The file should be highlighted.</p>
10	<p>Click on the Load button. A status report window is displayed showing the result of the download.</p>
11	<p>Click OK to close the status window.</p>
12	<p>From the Util pull down menu, select Tools, then Update NextLoad.</p>
13	<p>Select the version number of the folder that was used for the ROM code download and click Save. A pop-up message will appear showing the CDF file has been updated.</p>
14	<p>Click on the OK button to dismiss the pop-up message.</p>
15	<p>Click on the device that was loaded with ROM code.</p>
16	<p>NOTE RAM code is automatically selected for download.</p> <p>From the Device pull down menu, select Download Code to download RAM code. A status report is displayed showing the result of the download.</p>
17	<p>Click OK to close the status window.</p>
18	<p>Observe the downloaded device to ensure it is OOS-RAM (yellow) for non-GLI devices or INS (green) for GLIs.</p>
19	<p>Click on the device which was loaded with code.</p>
20	<p>From the Device pull down menu, select Status. Verify that the correct ROM and RAM version numbers are displayed in the status report window.</p>
21	<p>Click OK to close the status window.</p>
	<p>NOTE Data is automatically downloaded to GLI devices when the RAM code is downloaded. Use the data download portion of the <i>Download RAM Code and Data to Non-GLI Devices</i> procedure, Table 3-15, to download data to other device types after their ROM code has been upgraded and RAM code downloaded.</p>



Appendix H: In-Service Calibration

Appendix Content

Introduction	H-1
Purpose	H-1
Equipment Warm up	H-1
1X Test Equipment Requirements	H-1
Power Delta Calibration	H-3
Power Delta Calibration Introduction	H-3
Agilent E4406A Power Delta Calibration	H-3
Advantest R3267 Power Delta Calibration	H-6
Agilent 8935 series E6380A Power Delta Calibration	H-9
HP8921A Power Delta Calibration	H-12
Advantest R3465 Power Delta Calibration	H-15
In-Service Calibration	H-18
In-Service Calibration for 1X Upgrade	H-18



Introduction

Purpose

This procedure is a guide to performing calibration of new BTS expansion carriers while the system remains in service. This procedure also supports BTS recalibration following replacement of RF chain components while the remainder of the site stays in service.

Motorola recommends performing this procedure during a maintenance window.

This procedure cannot be performed on BTSs with 2-to-1 combiners. The procedure can only be performed on one side of the BTS at one time. That is, LPAs 1A, 1B, 1C, and 1D can be calibrated while LPAs 3A, 3B, 3C, and 3D remain in service and vice versa.

Equipment Warm up



IMPORTANT

Calibration of the communications test set (or equivalent test equipment) **must be** performed at the site before calibrating the overall *test equipment set*. Calibrate the test equipment *after* it has been allowed to warm-up and stabilize for a *minimum of 60 minutes*.



CAUTION

If any component of the *test equipment set* (for example, a test cable, RF adapter, signal generator) has been replaced, the *test equipment set* must be recalibrated. Failure to do so could introduce measurement errors which ultimately result in degradation of system performance.

1X Test Equipment Requirements

Calibration of 1X carrier functions requires using either of the following test equipment combinations:

- An Advantest R3267 spectrum analyzer with an Advantest R3562 signal generator
- An Agilent E4406A Transmitter Test Set with an Agilent E4432A signal generator
- An Agilent 8935 series E6380A equipped with option 200 (if purchased new) or option R2K (if retrofitted) and an Agilent E4432B signal generator

These test equipment combinations are capable of calibrating the BTS for both IS-95 A and B mode operation as well as IS-2000 CDMA 1X operation.



IMPORTANT

IS-95A/B communication test sets such as the HP8921A/600 and Advantest R3561L *can not calibrate 1X carrier functions.*

Calibration and test set-up for the HP 8921A/600 and Advantest R3561L test sets is included only for situations where it is necessary to use them for calibration of IS-95A/B mode operation.

■
H
■

Power Delta Calibration

Power Delta Calibration Introduction

The ISC procedure has several differences from a normal calibration procedure. One of these is the use of a spectrum analyzer/communications test set instead of a power meter to measure power. Power meters are broadband measurement devices and cannot be used to measure power during ISC because other carriers are operating. A spectrum analyzer can be used because it measures power at a given frequency. Measuring power using a spectrum analyzer is less accurate than using a power meter, therefore, compensation is required for the accuracy difference (delta) between the power meter and the spectrum analyzer.

Agilent E4406A Power Delta Calibration

The Agilent E4406A transmitter tester and E4432B signal generator test equipment combination can be used for ISC of IS-2000 CDMA 1X as well as IS-95A/B operation modes. The power delta calibration is performed on the E4406A, but the E4432B is required to generate the reference signal used to calculate the power delta offset. After the offset value has been calculated, add it to the TX cable loss value in the LMF.

Follow the procedure in Table H-1 to perform the Agilent E4406A Power Delta Calibration procedure.

Table H-1: Agilent E4406A Power Delta Calibration Procedure

Step	Action
	<p>* IMPORTANT</p> <p>Perform this procedure <i>after</i> test equipment has been allowed to warm-up and stabilize for a <i>minimum of 60 minutes</i>. After it is warmed up and stabilized, calibrate the test equipment as described in the “Test Set Calibration” section of Chapter 3.</p>
1	<p>Zero the Power Meter prior to connecting the power sensor to the RF cable from the signal generator.</p> <p>* IMPORTANT</p> <p>For best accuracy, always re-zero the power meter before connecting the power sensor to the component being calibrated.</p>
2	<p>Connect a short RF cable from the E4432B RF OUTPUT connector the HP437 power meter power sensor (see Figure H-1).</p>
3	<p>Set the E4432B signal generator as follows:</p> <ul style="list-style-type: none">– Press Preset to exit any modes for which the signal generator is configured– Press Frequency and enter the <i>frequency</i> of the channel to be calibrated on the numeric keypad– Using the soft keys to the right of the screen, select the frequency range to be measured; for example MHz– Press Amplitude and, using the numeric keypad, set signal amplitude to 0 (zero)– Using the soft keys, set the measurement type to dBm

. . . continued on next page



Power Delta Calibration – continued

Table H-1: Agilent E4406A Power Delta Calibration Procedure

Step	Action
4	On the E4432B, press RF On/Off to toggle the RF output to RF ON . – Note that the RF On/Off status in the screen display changes.
5	Measure and record the value reading on the HP437 power meter as result A _____.
6	On the E4432B, press RF On/Off to toggle the RF output to RF OFF . – Note that the RF On/Off status in the screen display changes.
7	Disconnect the short RF cable from the HP437 power meter power sensor, and connect it to the RF INPUT connector on the E4406A transmitter tester (see Figure H-2).
8	<p>* IMPORTANT</p> <p>Do not change the frequency and amplitude settings on the E4432B when performing the following steps.</p> <p>Set the E4406A as follows:</p> <ul style="list-style-type: none"> – Press Preset to exit any modes for which the transmitter tester is configured – Press MODE and, using the soft keys to the right of the screen, select cdmaOne – Press MEASURE and, using the soft keys, select spectrum – Press Frequency and, using the soft keys, select Center Frequency – Enter the <i>frequency</i> of the channel to be calibrated using the numeric keypad – Using the soft keys, select the frequency range to be measured; for example, MHz – Press Input/Output and, using the soft keys, select Input Atten – Using the numeric keypad, set Input Atten to 0 (zero) and, using the soft keys, select dB – Using the soft keys, select External Atten and then select Mobile – Using the numeric keypad, set Mobile to 0 (zero) and, using the soft keys, select dB – Using the soft keys, select Base – Using the numeric keypad, set Base to 0 (zero) and, using the soft keys, select dB – Press MEASURE and, using the soft keys, select Channel Power
9	On the E4432B signal generator, press RF On/Off to toggle the RF output to RF ON . – Note that the RF On/Off status in the screen display changes.
10	Read the measured Channel Power from the E4406A screen display and record it as result B _____.
11	On the E4432B, press RF On/Off to toggle the RF output to RF OFF . – Note that the RF On/Off status in the screen display changes.

... continued on next page

Power Delta Calibration – continued

Table H-1: Agilent E4406A Power Delta Calibration Procedure

Step	Action
12	<p>Calculate the Power Calibration Delta value. The delta value is the power meter measurement minus the Agilent measurement.</p> <p>Delta = A – B</p> <p>Example: Delta = $-0.70 \text{ dBm} - (-1.25 \text{ dBm}) = 0.55 \text{ dBm}$</p> <p>Example: Delta = $0.26 \text{ dBm} - 0.55 \text{ dBm} = -0.29 \text{ dBm}$</p> <p>These examples are included to show the mathematics and do not represent actual readings.</p> <p>NOTE</p> <p>Add this delta value to the TX Cable Loss value during In-Service Calibration (see step 4 in Table H-6).</p>

Figure H-1: Delta Calibration Setup – Agilent E4432B to HP437

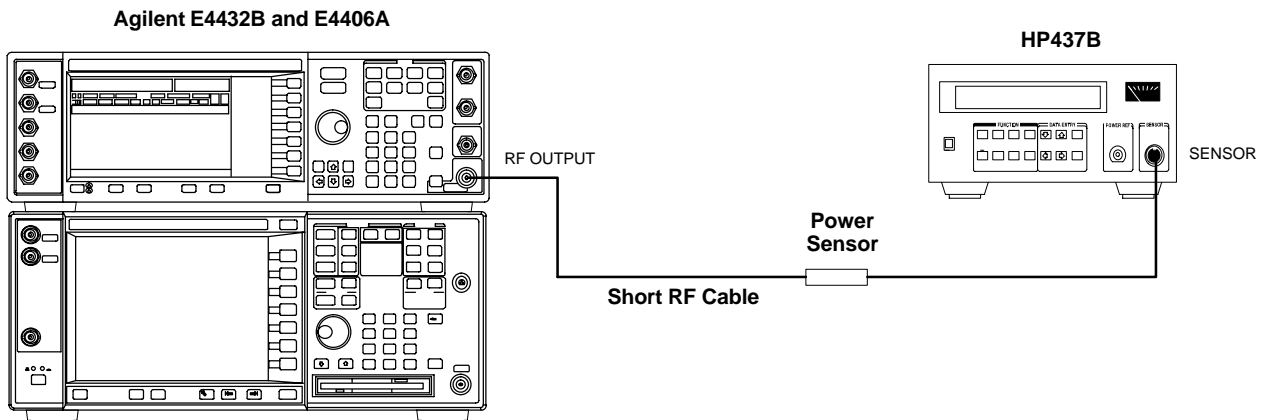
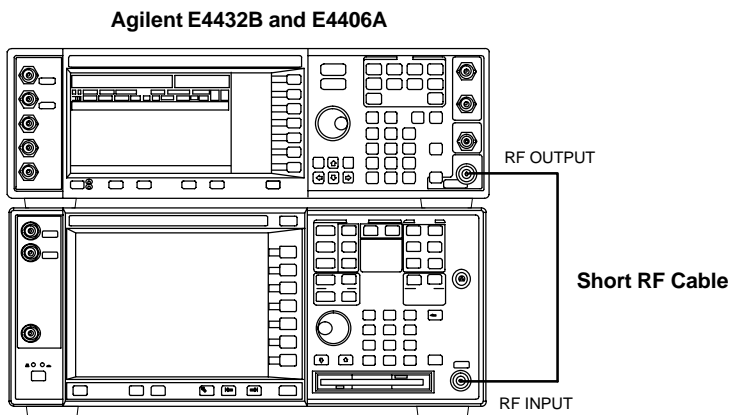

Figure H-2: Delta Calibration Setup – Agilent E4432B to Agilent E4406A



H

Power Delta Calibration – continued

Advantest R3267 Power Delta Calibration

The Advantest R3267 spectrum analyzer and R3562 signal generator test equipment combination can be used for ISC of IS–2000 CDMA 1X as well as IS–95A/B operation modes. The power delta calibration is performed on the R3267. After the offset value has been calculated, add it to the TX cable loss value.

Follow the procedure in Table H-2 to perform the Advantest R3267 Power Delta Calibration procedure.

Table H-2: Advantest R3267 Power Delta Calibration Procedure

Step	Action
1	<p>* IMPORTANT</p> <p>Warm-up <i>test equipment for a minimum of 60 minutes</i> prior to this procedure. After it is warmed up and stabilized, calibrate the test equipment as described in the “Test Set Calibration” section of Chapter 3.</p> <p>Press the SHIFT and the PRESET keys located on the right side of the control panel.</p>
2	Press the ADVANCE key in the MEASUREMENT area of the control panel.
3	On the CRT, select RX Control by pressing ACTIVE key 1.
4	On the CRT, select Frequency Setup by pressing ACTIVE key 3.
5	On the CRT, highlight Frequency by adjusting the DISPLAY CONTROL knob.
6	Press FREQ key in the ENTRY section of the control panel.
7	Set the frequency to the desired value using the keypad ENTRY section keys.
8	Press the LEVEL key in the ENTRY section of the control panel.
9	Set the level to 0 dBm using the keypad ENTRY section keys.
10	On the CRT, verify OFF is highlighted in Modulation , if not press the ACTIVE key 5 to toggle it OFF.
11	On the CRT, verify OFF is highlighted in Output , if not press the ACTIVE key 6 to toggle it OFF.
12	<p>Zero the Power Meter prior to connecting the power sensor to the RF cable from the signal generator.</p> <p>* IMPORTANT</p> <p>For best accuracy, always re-zero the power meter before connecting the power sensor to the component being calibrated.</p>
13	Connect the RF cable from the R3562 signal generator RF OUT port to the power sensor, refer to Figure H-3.
14	On the R3562 CRT, set the Output to ON by pressing ACTIVE key 6.
15	Record the Power Meter reading as result A _____
16	On the R3562 CRT, set the Output to OFF by pressing ACTIVE key 6.

. . . continued on next page

Power Delta Calibration – continued

Table H-2: Advantest R3267 Power Delta Calibration Procedure	
Step	Action
17	Connect the RF cable from R3562 signal generator RF OUT port to the R3267 spectrum analyzer INPUT Port, refer to Figure H-4.
18	On the R3562 CRT, set the Output to ON by pressing ACTIVE key 6.
19	On the R3267, press the POWER key in the MEASUREMENT section of the control panel.
20	Press the LEVEL key in the ENTRY section of the control panel.
21	Set the REF LEVEL to 10 dBm using the keypad ENTRY section keys.
22	On the CRT, select dB/div by pressing ACTIVE key 1.
23	On the CRT, select 10 dB/div by pressing ACTIVE key 1.
24	Press the FREQ key in ENTRY section of the control panel.
25	Set the frequency to the desired value using the keypad ENTRY section keys.
26	On the CRT, select more 1/2 by pressing ACTIVE key 7.
27	Press the Preselector CRT menu key to highlight 3.66G .
28	Press the POWER key in the MEASUREMENT section of the control panel.
29	Press the SPAN key in the ENTRY section of the control panel.
30	On the CRT, select Zero Span by pressing ACTIVE key 2.
31	Press the COUPLE key in the ENTRY section of the control panel.
32	On the CRT, select RBW and highlight MNL by pressing ACTIVE key 3.
33	Set RBW to 30 kHz using keypad ENTRY section keys.
34	On the CRT, select VBW and highlight MNL by pressing ACTIVE key 2.
35	Set VBW to 1 MHz using keypad ENTRY section keys.
36	Press the MKR key in the DISPLAY CONTROL section of the control panel.
37	On the CRT, select Normal Marker by pressing ACTIVE key 1.
38	Record the Marker Level reading as result B _____
39	Press Single in ENTRY section of control panel.

. . . continued on next page



Power Delta Calibration – continued

Table H-2: Advantest R3267 Power Delta Calibration Procedure	
Step	Action
40	<p>Calculate the Power Calibration Delta value. The delta value is the power meter measurement minus the Advantest measurement.</p> <p>Delta = A – B</p> <p>Example: Delta = $-0.7 \text{ dBm} - (-1.25 \text{ dBm}) = 0.55 \text{ dB}$</p> <p>Example: Delta = $0.26 \text{ dBm} - 0.55 \text{ dBm} = -0.29 \text{ dBm}$</p> <p>These examples are included to show the mathematics and do not represent actual readings.</p> <p>NOTE</p> <p>Add this delta value to the TX Cable Loss value during In-Service Calibration (see step 4 in Table H-6).</p>

Figure H-3: Delta Calibration Setup – Advantest R3562 to HP437

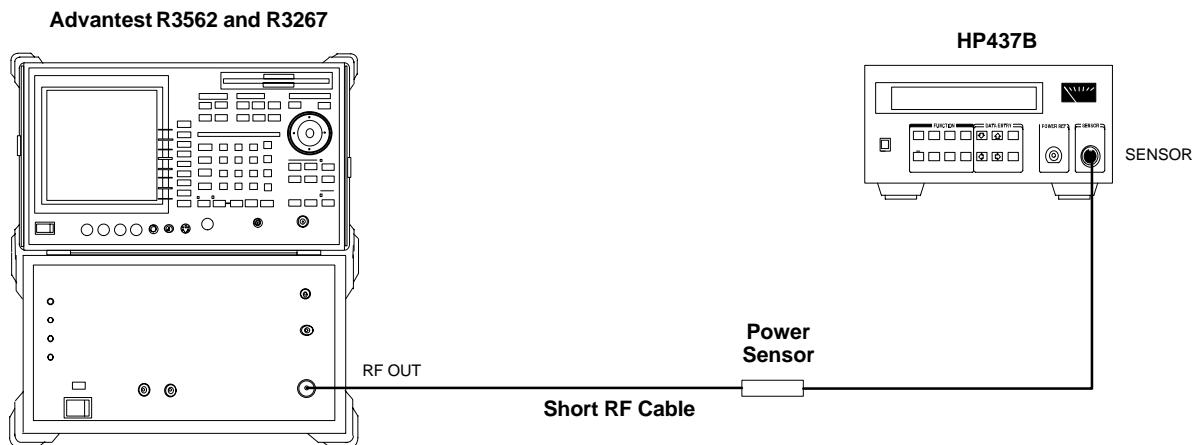
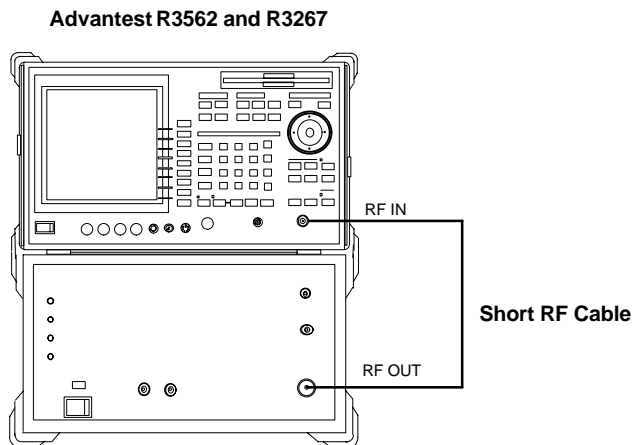

Figure H-4: Delta Calibration Setup – Advantest R3562 to R3267



Power Delta Calibration – continued

Agilent 8935 series E6380A Power Delta Calibration

The Agilent E6380A (formerly HP8935) communications test set modified with either option 200 or R2K and E4432B signal generator test equipment combination can be used for ISC of IS–2000 CDMA 1X as well as IS–95A/B operation modes. The power delta calibration is performed on the E6380A. After the offset value has been calculated, add it to the TX cable loss value.

Follow the procedure in Table H-3 to perform the Agilent E6380A Power Delta Calibration procedure.

Table H-3: Agilent E6380A Power Delta Calibration Procedure

Step	Action
	<p>* IMPORTANT</p> <p>Perform this procedure <i>after</i> test equipment has been allowed to warm-up and stabilize for a <i>minimum of 60 minutes</i>. After it is warmed up and stabilized, calibrate the test equipment as described in the “Test Set Calibration” section of Chapter 3.</p>
1	<p>Zero the Power Meter prior to connecting the power sensor to the RF cable from the signal generator.</p> <p>* IMPORTANT</p> <p>For best accuracy, always re-zero the power meter before connecting the power sensor to the component being calibrated.</p>
2	Connect a short RF cable between the E6380A Duplex Out port and the HP437 power sensor (see Figure H-5).
3	<p>Set the E6380A signal source as follows:</p> <ul style="list-style-type: none"> – Measure mode to CDMA Gen – Frequency to the CDMA Calibration target frequency – CW RF Path to IQ – Output Port to Dupl – Data Source to Random – Amplitude to 0 dBm
4	Measure and record the power value reading on the HP437 Power Meter.
5	Record the Power Meter reading as result A _____.
6	<p>Turn off the E6380A signal source output, and disconnect the HP437.</p> <p>NOTE</p> <p>Leave the settings on the source E6380A for convenience in the following steps.</p>
7	Connect the short RF cable between the E6380A Duplex Out port and the RF-IN/OUT port (see Figure H-6).
8	Ensure that the source E6380A settings are the same as in Step 3.

. . . continued on next page

Power Delta Calibration – continued

Table H-3: Agilent E6380A Power Delta Calibration Procedure	
Step	Action
9	Set the E6380A as follows: <ul style="list-style-type: none"> – Measure mode to CDMA AnI – Frequency to the CDMA calibration target frequency – Input Attenuation to 0 dB – Input port to RF-IN – Gain to Auto – AnI Dir to Fwd
10	Turn on the E6380A signal output.
11	Set the Chn Pwr Cal to Calibrate and select to calibrate.
12	Measure and record the channel power reading on the measuring E6380A as result B _____.
13	Turn off the E6380A signal output and disconnect the equipment.
14	<p>Calculate the Power Calibration Delta value. The delta value is the power meter measurement minus the Advantest measurement.</p> <p style="padding-left: 40px;">Delta = A – B</p> <p style="padding-left: 40px;">Example: Delta = –0.70 dBm – (–1.25 dBm) = 0.55 dBm</p> <p style="padding-left: 40px;">Example: Delta = 0.26 dBm – 0.55 dBm = –0.29 dBm</p> <p>These examples are included to show the mathematics and do not represent actual readings.</p> <p>NOTE</p> <p>Add this delta value to the TX Cable Loss value during In–Service Calibration (see Step 4 in Table H-6).</p>

Figure H-5: Delta Calibration Setup – E6380A to HP437

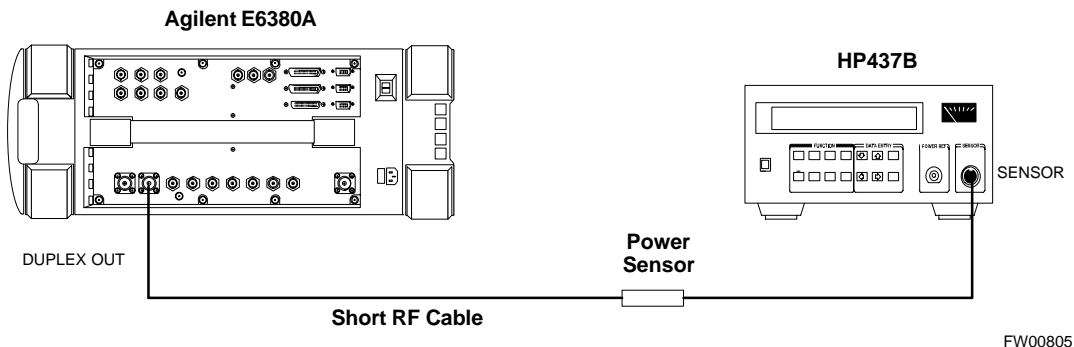

Power Delta Calibration – continued

Figure H-6: Delta Calibration Setup – E6380A to E6380A

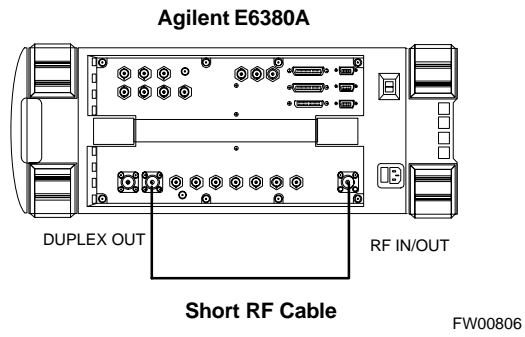

■
H
■

Power Delta Calibration – continued

HP8921A Power Delta Calibration

Use the HP8921A communications test set to measure power during ISC *only for IS-95A and B operation* of 800 MHz systems. After the offset value has been calculated, add it to the TX cable loss value.

Follow the procedure in Table H-4 to perform the HP8921A Power Delta Calibration procedure.

NOTE

This procedure requires two HP8921A communication test sets.

Table H-4: HP8921A Power Delta Calibration Procedure

Step	Action
	<p>* IMPORTANT</p> <p>Perform this procedure <i>after</i> test equipment has been allowed to warm-up and stabilize for a <i>minimum of 60 minutes</i>. After it is warmed up and stabilized, calibrate the test equipment as described in the “Test Set Calibration” section of Chapter 3.</p>
1	<p>Zero the Power Meter prior to connecting the power sensor to the RF cable from the signal generator.</p> <p>* IMPORTANT</p> <p>For best accuracy, always re-zero the power meter before connecting the power sensor to the component being calibrated.</p>
2	<p>Connect a short RF cable between the HP8921A Duplex Out port and the HP437 power sensor (see Figure H-7).</p>
3	<p>Set the HP8921A signal source as follows:</p> <ul style="list-style-type: none"> – Measure mode to CDMA Generator – Frequency to the CDMA Calibration target frequency – CW RF Path to IQ – Output Port to Dupl – Data Source to Random – Amplitude to 0 dBm
4	<p>Measure and record the power value reading on the HP437 Power Meter.</p>
5	<p>Record the Power Meter reading as result A _____.</p>
6	<p>Turn off the source HP8921A signal output, and disconnect the HP437.</p> <p>NOTE</p> <p>Leave the settings on the source HP8921A for convenience in the following steps.</p>
7	<p>Connect the short RF cable between the source HP8921A Duplex Out port and the measuring HP8921A RF-IN port (see Figure H-8).</p>
8	<p>Ensure that the source HP8921A settings are the same as in Step 3.</p>

. . . continued on next page

Power Delta Calibration – continued

Table H-4: HP8921A Power Delta Calibration Procedure	
Step	Action
9	Set the measuring HP8921A as follows: <ul style="list-style-type: none"> – Measure mode to CDMA AnI – Frequency to the CDMA calibration target frequency – Input Attenuation to 0 dB – Input port to RF-IN – Gain to Auto – Analyzer Direction to Fwd
10	Turn on the source HP8921A signal output.
11	Measure and record the channel power reading on the measuring HP8921A as result B _____.
12	Turn off the source HP8921A signal output and disconnect the equipment.
13	Compute the delta between HP437 and HP8921A using the following formula: Delta = A – B Example: Delta = -0.70 dBm – (-1.25 dBm) = 0.55 dBm Example: Delta = 0.26 dBm – 0.55 dBm = -0.29 dBm These examples are included to show the mathematics and do not represent actual readings. NOTE Add this delta value to the TX Cable Loss value during In-Service Calibration (see Step 4 in Table H-6).

Figure H-7: Delta Calibration Setup – HP8921A to HP437

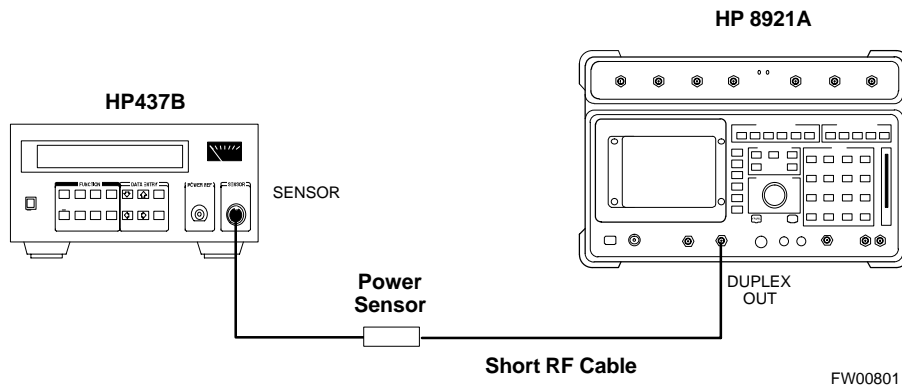

H

Power Delta Calibration – continued

Figure H-8: Delta Calibration Setup – HP8921A to HP8921A

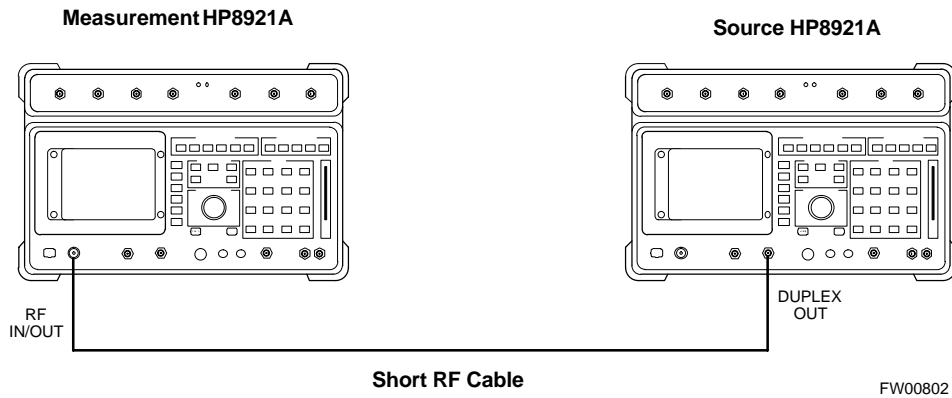

H

Power Delta Calibration – continued

Advantest R3465 Power Delta Calibration

Use the Advantest R3465 spectrum analyzer to measure power during ISC *only for IS-95A and B operation*. After the offset value has been calculated, add it to the TX cable loss value.

Follow the procedure in Table H-5 to perform the Advantest 3465 Power Delta Calibration procedure.

Table H-5: Advantest Power Delta Calibration Procedure	
Step	Action
	<p>* IMPORTANT</p> <p>Perform this procedure <i>after</i> test equipment has been allowed to warm-up and stabilize for a <i>minimum of 60 minutes</i>. After it is warmed up and stabilized, calibrate the test equipment as described in the “Test Set Calibration” section of Chapter 3.</p>
1	Press the SHIFT and the PRESET keys located below the CRT display.
2	Press the ADVANCE key in the Measurement area of the control panel.
3	Press the CDMA Sig CRT menu key.
4	Press the FREQ key in the Entry area of the control panel.
5	Set the frequency to the desired value using the keypad entry keys.
6	Press the LEVEL key in the Entry area of the control panel.
7	Set the LEVEL to 0 dBm using the keypad entry keys.
8	Verify the Mod CRT menu key is highlighting OFF , if not press the Mod key to toggle it OFF .
9	Verify the Output CRT menu key is highlighting OFF , if not press the Output key to toggle it OFF .
10	<p>Zero the Power Meter prior to connecting the power sensor to the RF cable from the signal generator.</p> <p>* IMPORTANT</p> <p>For best accuracy, always re-zero the power meter before connecting the power sensor to the component being calibrated.</p>
11	Connect the RF cable from the R3561L CDMA signal generator RF OUT port to the power sensor, refer to Figure H-9.
12	Press the Output CRT menu key to toggle the Output to ON .
13	Record the Power Meter reading as result A _____.
14	Press the Output CRT menu key to toggle the Output to OFF .
15	Connect the RF cable from the R3561L signal generator RF OUT port to the R3465 INPUT Port, refer to Figure H-10.
16	Press the Output CRT menu key to change the Output to ON .
17	Press the CW key in the Measurement area of the control panel.
18	Press the LEVEL key in the Entry area of the control panel.
19	Set the REF LEVEL to 10 dBm using the keypad entry keys.

. . . continued on next page



Power Delta Calibration – continued

Table H-5: Advantest Power Delta Calibration Procedure

Step	Action
20	Press the dB/div CRT menu key.
21	Press the 10 dB/div CRT menu key.
22	Press the FREQ key in Entry area of the control panel.
23	Set the frequency to the desired value using the keypad entry keys.
24	Press the more 1/2 CRT menu key.
25	Press the Preselector CRT menu key to highlight 3.0G .
26	Press the FORMAT key in the Display Control area of the control panel.
27	Press the TRACE CRT menu key.
28	Press the AVG A CRT menu key.
29	Set AVG to 20 using keypad entry keys.
30	Press the return CRT menu key.
31	Press the SPAN key in the Entry area of the control panel.
32	Press the Zero Span CRT menu key.
33	Press the BW key in the Entry area of the control panel.
34	Press the RBW CRT menu key to highlight MNL . using keypad entry keys enter 30 kHz .
35	Set RBW to 30 kHz using keypad entry keys.
36	Press the VBW CRT menu key to highlight MNL .
37	Set VBW to 1 MHz using keypad entry keys.
38	Press the Marker ON key in the Display Control area of the control panel.
39	Record the Marker Level reading as result B _____.
40	<p>Calculate the Power Calibration Delta value. The delta value is the power meter measurement minus the Advantest measurement.</p> <p style="padding-left: 40px;">Delta = A – B</p> <p style="padding-left: 40px;">Example: Delta = –0.70 dBm – (–1.25 dBm) = 0.55 dBm</p> <p style="padding-left: 40px;">Example: Delta = 0.26 dBm – 0.55 dBm = –0.29 dBm</p> <p>These examples are included to show the mathematics and do not represent actual readings.</p> <p>NOTE</p> <p>Add this delta value to the TX Cable Loss value during In–Service Calibration (see Step 4 in Table H-6).</p>

Power Delta Calibration – continued

Figure H-9: Delta Calibration Setup – R3561L to HP437

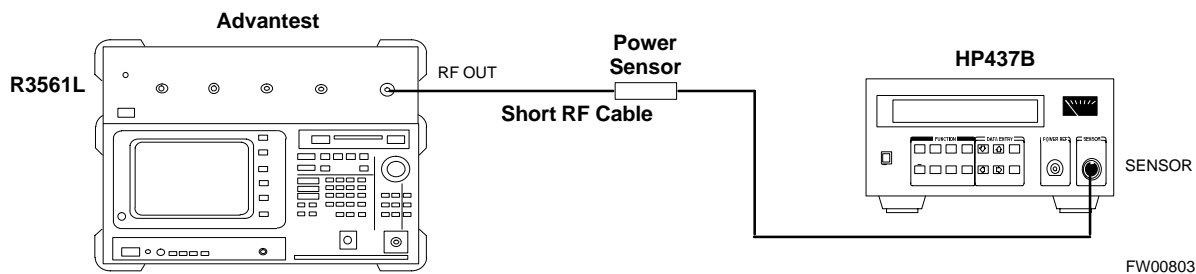
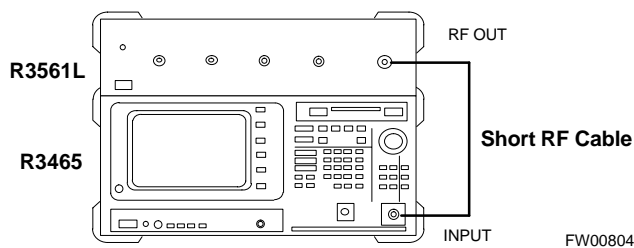

Figure H-10: Delta Calibration Setup – R3561L to R3465



In-Service Calibration for 1X Upgrade



IMPORTANT

This feature does NOT have fault tolerance at this time. *The system has no safe-guards to prevent actions which will put the BTS out of service.* If possible, perform this procedure during a maintenance window.

Follow the procedures in this section precisely, otherwise the entire BTS will most likely go OUT OF SERVICE.

At the CBSC, only perform operations on expansion hardware when it is in the OOS_MANUAL state.

The operator must be trained in the LMF operation prior to performing this procedure.

Prerequisites

- Expansion hardware has been added in the CBSC database, and the CDF file has been generated.
- The expansion devices have been inserted into the C-CCP cage and are in the OOS_MANUAL state at the CBSC MM.
- The site specific CDF (with the expansion hardware) and CAL files have been loaded onto the LMF.
- The LMF has the same code and dds files as the CBSC to download.



IMPORTANT

Do not download code or data to any cards other than those you are working on. Downloading code or data to other cards will take the site OUT OF SERVICE.

The code file version numbers must match the version numbers required for the upgrade cards (refer to NO TAG). If the numbers do not match, the site may go OUT OF SERVICE.

It is *mandatory* that the **bts-#.cdf** and **cbsc-#.cdf** files on the LMF computer for this BTS are copies of the corresponding files created in the CBSC database (see NO TAG).

The CAL file loaded on the LMF computer for this BTS must have come from the CBSC.

- Test equipment has been configured per Figure H-11, Figure H-12, Figure H-13, or Figure H-14.

In-Service Calibration – continued

- An RFDS (or at a minimum a directional coupler), whose loss is already known, must be in line to perform the in-service calibration.
- Test equipment has been calibrated after 1 hour warm up.
- A short RF cable and two BNC-N adapters are available to perform Cable Calibration.
- The Power Delta Calibration has been performed (see Table H-1, Table H-2, Table H-3, Table H-4, or Table H-5).



H



Figure H-11: Optimization/ATP Test Setup Using Directional Coupler – Agilent Test Equipment

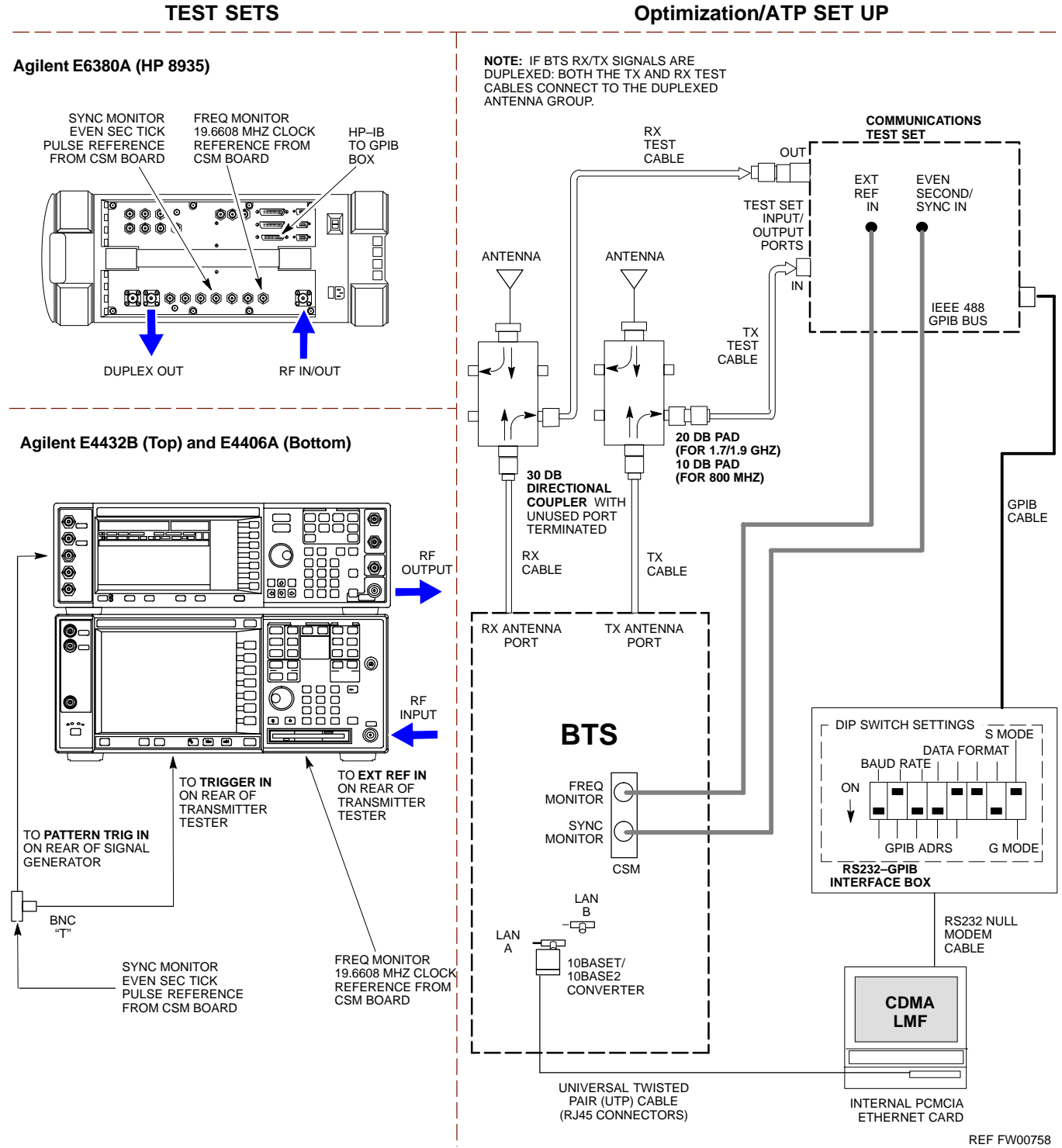

H

Figure H-12: Optimization/ATP Test Setup Using Directional Coupler – Advantest R3267/R3562 Test Equipment

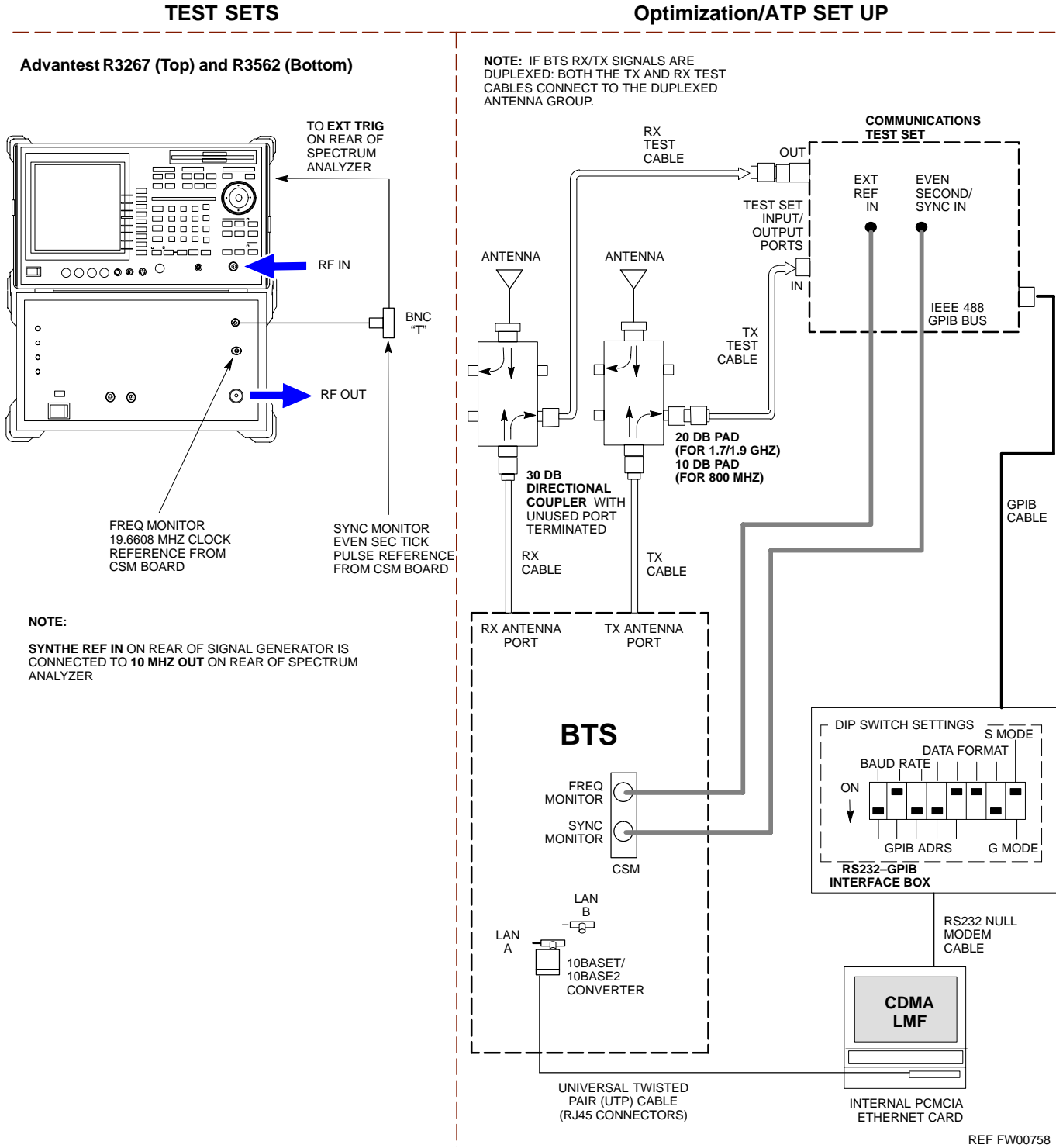
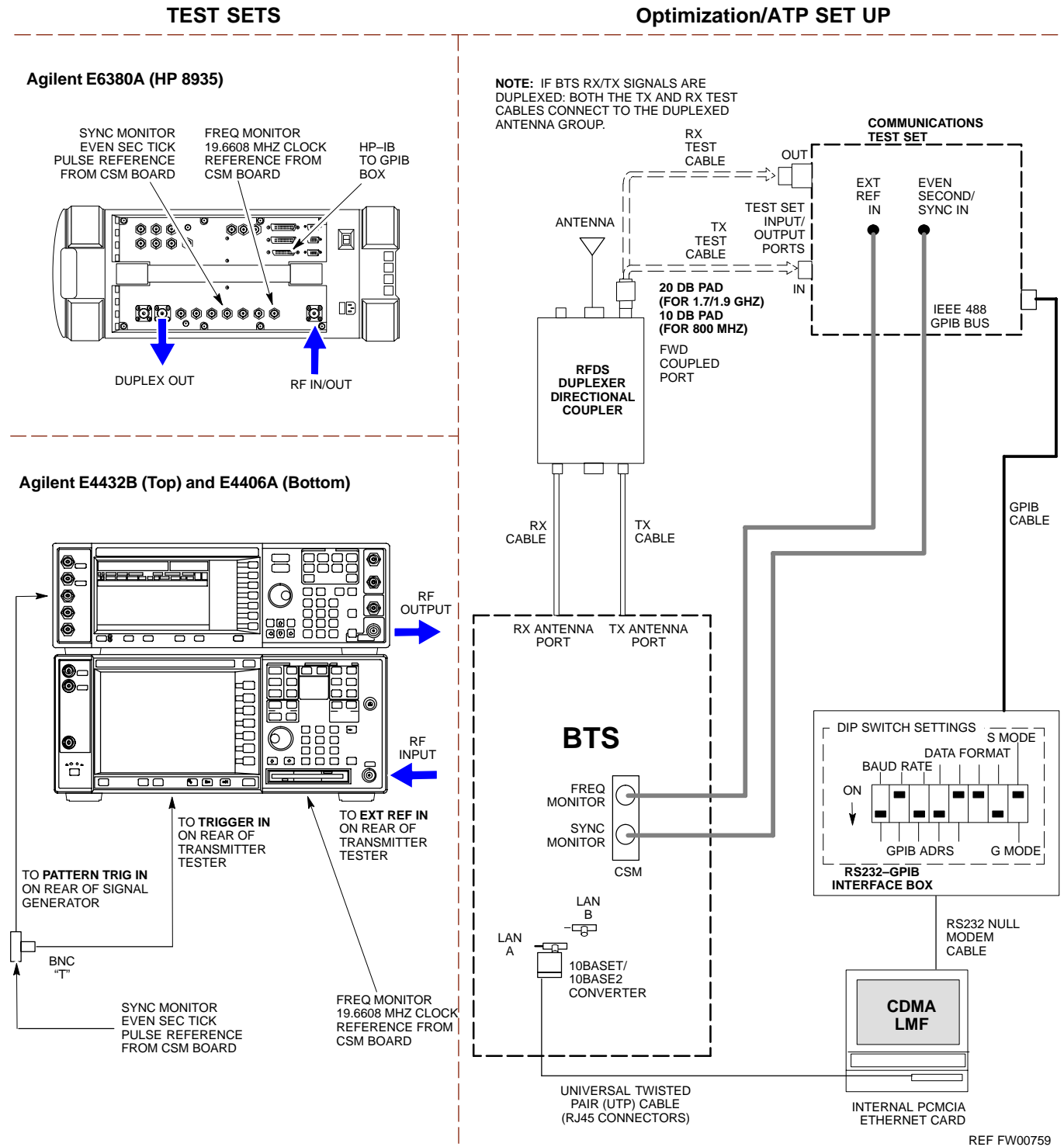
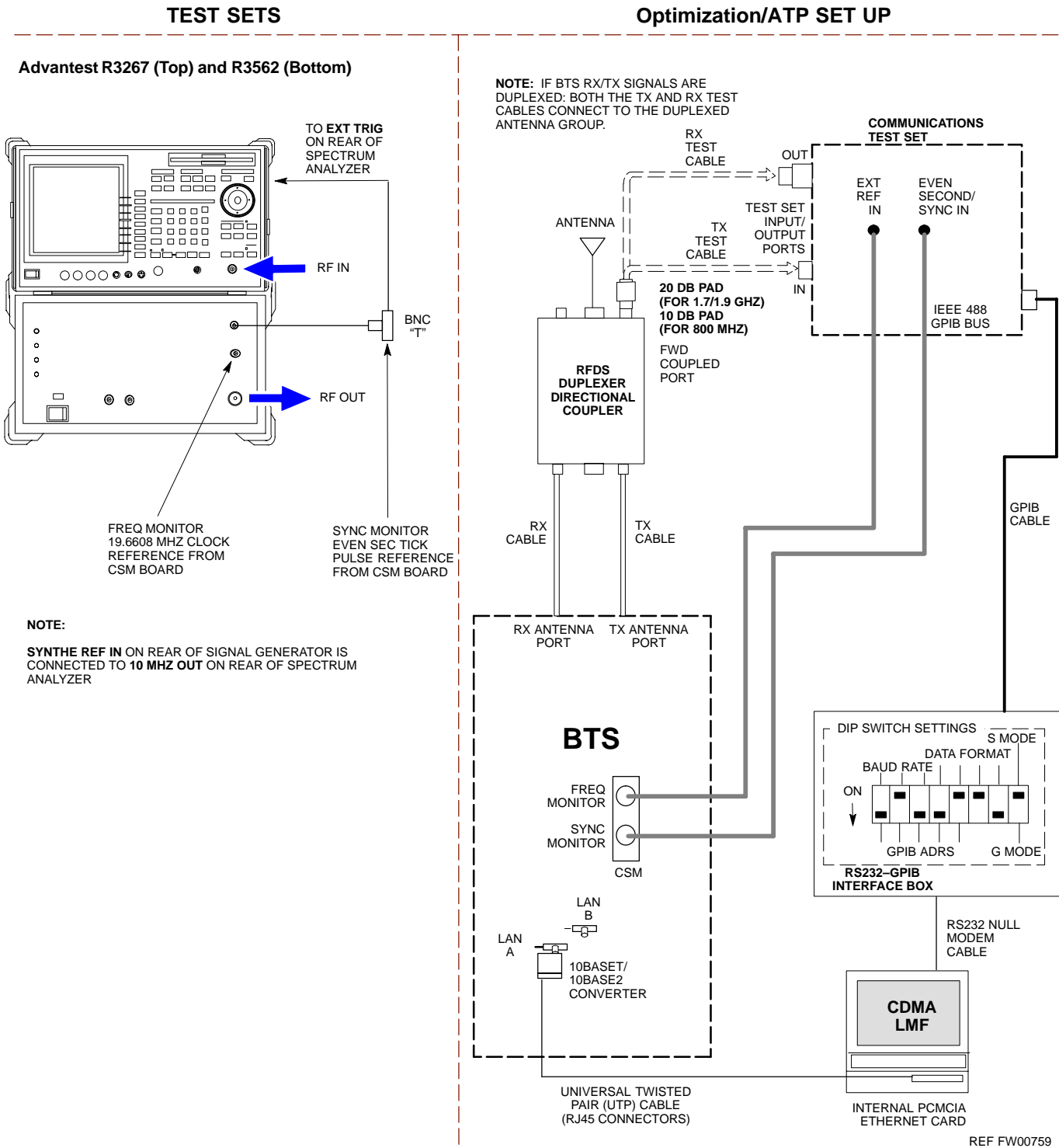

Figure H-13: Optimization/ATP Test Setup Using RFDS – Agilent Test Equipment



H

Figure H-14: Optimization/ATP Test Setup Using RFDS – Advantest R3267/R3562 Test Equipment



In-Service Calibration – continued

Follow the procedure in Table H-6 to perform the In-Service Calibration.

Table H-6: In-Service Calibration	
Step	Action
	<p>* IMPORTANT</p> <p>Perform this procedure <i>after</i> test equipment has been allowed to warm-up and stabilize for a <i>minimum of 60 minutes</i>.</p>
1	<p>Set up the LMF for In-Service Calibration:</p> <ul style="list-style-type: none"> – Start the LMF by double-clicking the LMF icon on the Windows desktop. – Click Tools > Options from the menu bar at the login screen. – Check only the applicable spectrum analyzer check box on the Test Equipment tab. Ensure that the GPIB address is 18. – Uncheck any other other equipment that is selected. – Click the Apply button. – Select the BTS Options tab in the LMF Options window. – Check the In-Service Calibration check box. – Click the Apply button. – Click the Dismiss button to close the LMF Option window.
2	<p>Login to the target BTS:</p> <ul style="list-style-type: none"> – Select the target BTS icon. – Click the Login button at the login screen.
3	<p>Measure the Cable Loss using the Cable Calibration function:</p> <ul style="list-style-type: none"> – Click Util > Cable Calibration from the menu bar at the main window. – Set the desired channel(s) and select TX and RX CABLE CAL in the cable calibration pop-up window. – Click the OK button to perform cable calibration. – Follow the on-screen instructions to complete the cable loss measurement. <p>NOTE</p> <ul style="list-style-type: none"> – The measured value is input automatically to the cable loss file. – To view the cable loss file, click Util > Examine > Cable Loss.

. . . continued on next page



Table H-6: In-Service Calibration

Step	Action
4	<p>Add the spectrum analyzer power delta to the TX Cable Loss.</p> <ul style="list-style-type: none"> – Click Util > Edit > Cable Loss > TX. – Add the value computed in Table H-4, Table H-5, or Table H-3 to the TX Cable Loss. <p>NOTE</p> <p>Be sure to include the sign of the value. The following examples are included to show the mathematics and do not represent actual readings:</p> <ul style="list-style-type: none"> – Example: 5.65 dBm + 0.55 dBm = 6.20 dBm – Example: 5.65 dBm + (–0.29 dBm) = 5.36 dBm – Example: –5.65 dBm + 0.55 dBm = –5.10 dBm – Example: –5.65 dBm + (–0.29 dBm) = –5.94 dBm
5	<p>Input the Coupler Loss for the TX tests:</p> <ul style="list-style-type: none"> – Click Util > Edit > Coupler Loss > TX from the menu bar at the main window. – Enter the appropriate coupler loss for the target carrier(s) by referring to the information taken at the time of BTS installation. – Click the Save button. – Click the Dismiss button to close the window. – To view the coupler loss file, click Util > Examine > Coupler Loss.
6	<p>Input the Coupler Loss for the RX tests:</p> <ul style="list-style-type: none"> – Click Util > Edit > Coupler Loss > RX from the menu bar at the main window. – Enter the appropriate coupler loss for the target carrier(s) by referring to the information taken at the time of BTS installation. – Click the Save button. – Click the Dismiss button to close the window. – To view the couper loss file, click Util > Examine > Coupler Loss.
7	<p>If it was not previously done, have the CBSC operator put the redundant BBX OOS_MANUAL.</p>
	<p>! CAUTION</p> <p>Be sure to download OOS devices only. Loading in-service devices takes them OUT OF SERVICE and can result in dropped calls.</p> <p>The code file version numbers must match the version numbers on the other cards in the frame. If the numbers do not match, the site may go OUT OF SERVICE.</p> <p>NOTE</p> <p>Be sure to include the redundant BBX in steps 8, 9, and 10.</p>

... continued on next page



Table H-6: In-Service Calibration

Step	Action
8	Download code and data to the target devices: <ul style="list-style-type: none"> – Click Tools > Update NextLoad > CDMA to set the code version that will be downloaded. – Check the appropriate code version in the pop up window and click the Save button to close. – Select the target BBX(s) on the C-CCP cage picture. – Click Device > Download Code/Data to start downloading code and data.
9	<p>! CAUTION Perform the All Cal/Audit procedure on OOS devices only.</p> Run the All Cal/Audit procedure: <ul style="list-style-type: none"> – Select the target BBX(s) on the C-CCP cage picture. – Click Tests > All Cal/Audit from the menu bar at the main window. – Select the target carrier and confirm the channel number in the pop up window. – Leave the Verify BLO check box checked and click the OK button to start calibration. – Follow the on-screen instructions, except, do not connect to the BTS antenna port, connect to the directional coupler (fwd) port associated with the on screen prompt antenna port.
10	Save the result and download the BLO data to the target BBX(s): <ul style="list-style-type: none"> – Click the Save Result button on the result screen. The window closes automatically.
11	Logout from the BTS and close the LMF session: <ul style="list-style-type: none"> – Click Select > Logout to close the BTS connection. – Close the LMF window.
12	Restore the new “bts-*.cal” file to the CBSC (refer to Table 5-2).
13	Enable the target device(s) from the CBSC.



Numbers

- 10 MHz Rubidium Standard, optional test equipment, 1-11
- 10BaseT/10Base2 converter
 - LMF to BTS connection, 3-21
 - remove from BTS, 5-4
- 2-way splitter, optional test equipment, 1-10
- 50-pair punchblock, 3-18

A

- Abbreviated
 - RX acceptance test, all-inclusive, 4-4
 - TX acceptance test, all-inclusive, 4-4
- Acceptance Test Procedure. *See* ATP
- ACTIVE LED
 - GLI, 6-31
 - MCC, 6-33
- Alarm and Span Line Cable Pin/Signal Information, 3-18
- ALARM LED, GLI, 6-31
- Alarm Monitor window, 3-86
- Alarm Reporting Display, 3-86
- All RX ATP Test Procedure, 4-6
- All tests fail on a single antenna, Troubleshooting, RFDS, 6-26
- All TX ATP Test Procedure, 4-5
- All TX/RX ATP Test Procedure, 4-5
- Applying AC Power, 2-12
- ATP
 - all inclusive TX acceptance test outline, 4-4
 - automated introduction, 4-1
 - code domain noise floor acceptance test procedure, 4-16

- code domain power acceptance test procedure, 4-16
- failure report generation, 4-20
- FER test, frame error rate testing, 4-19
- pilot time offset, 4-13
- prerequisites, 4-2
- spectral purity TX mask, 4-10
- test matrix/detailed optimization, B-2
- waveform quality (Rho), 4-12
- waveform quality (RHO) acceptance test procedure, 4-12

Attenuator, required test equipment, 1-9

B

- Basic Troubleshooting Overview, 6-1
- Battery Charge Test (Connected Batteries), 2-15
- Battery Discharge Test, 2-16
- Bay Level offset calibration failure, 6-10
- BBX
 - carrier spectral purity, 4-9
 - gain set point vs SIF output considerations, C-1
 - primary and redundant, TX tests to be performed, 4-7
- BBX2 Connector, 6-20
- BBX2 LED Status Combinations, 6-33
- BDC, pilot gain setting, 4-18
- Bringing modules into service, prepare to leave the site, 5-3
- Broad Band Receiver. *See* BBX
- BTS
 - download, 3-32
 - Ethernet LAN interconnect diagram, 3-29
 - LMF connection, 3-15, 3-21
 - log out of session, 5-4
 - RX sensitivity/frame error rate, 4-8
 - system software download, 3-3
 - when to optimize, B-1

BTS Frame Erasure Rate. *See* FER

BTS Log In Procedure, GUI, 3-24

BTS login

CLI environment, 3-25

General, 3-23

GUI environment, 3-24

BTS Logout

CLI environment, 3-27

GUI environment, 3-26

Create CAL File, 3-76

bts–nnn.cal File, 3-10

C

Cables Connection for 10 MHz Signal and GPIB ,
F-2, F-4

Calibrate BLO, 3-65

Calibrating Cables, 3-59

Calibrating Test Cable Setup, PCS Interface
HP83236B, F-14

Calibrating Test Equipment, 3-59

Calibration

data file calibration, BLO, 3-67

power meter, Gigatronics 8542B, F-12

Calibration Audit failure, 6-11

calibration data file, description of, BLO, 3-67

Cannot communicate to Communications Analyzer,
6-6

Cannot communicate to Power Meter, 6-5

Cannot Download DATA to any device card, 6-7

Cannot ENABLE device, 6-8

Cannot Log into cell–site, 6-2

Cannot perform carrier measurement, 6-16

Cannot perform Code Domain Noise Power
measurement, 6-16

Cannot perform Rho or pilot time offset
measurement, 6-15

Cannot perform Txmask measurement, 6-15

cbsc folder, 3-11

CDF

site configuration, 3-2

site equipage verification, 3-3

site type and equipage data information, 2-1

CDMA

allocation diagram for the North American, cellular
telephone frequency spectrum, D-4

optimization/ATP test matrix, B-1

subscriber mobile radiotelephone, optional test
equipment, 1-11

cdma Folder, 3-9

CDMA LMF and Logical BTS, 3-22

Cell Site

equipage verification, 2-1

types configuration, 3-2

Cell Site Data File. *See* CDF

Channel Service Unit, 3-15

CIO Connectors, 6-21

Clock Sync Module. *See* CSM

Code domain power/noise floor

acceptance test, 4-15

analyzer display, 4-17

code Folder, 3-11

Communication test set, rear panel, F-2, F-4

Communications test set. *See* Test equipment

Connect BTS E1/T1 spans, 5-5

Connect BTS T1/E1 spans, 5-5

Connecting test equipment to the BTS, 3-48

Connector Functionality

Backplane, Troubleshooting, 6-20

Troubleshooting, Backplane, 6-20

Control, TX output verification, 4-3

Copy CBSC CDF Files to the LMF, 3-5

Copying CAL files from CDMA LMF to the CBSC,
5-1

Copying CAL files to the CBSC, 5-1

CSM, and LFR primary functions, 3-38

CSM frequency verification, 3-40

CSM LED Status Combinations, 6-29

D

data Folder, 3-12

DC Power Pre–test (BTS Frame), 2-7

Index – continued

DC Power Problems, C–CCP Backplane
 Troubleshooting, 6-24

DC/DC Converter LED Status Combinations, 6-28

Detailed, optimization/ATP test matrix, B-2

Devices, download. *See* Download

Digital Control Problems, 6-21
 C–CCP Backplane Troubleshooting, 6-21

Digital multimeter, required test equipment, 1-9

Directional coupler, required test equipment, 1-9

Documents, required, 1-12

Download
 See also Devices
 BTS, 3-32
 BTS system software, 3-3

Download BLO Procedure, 3-73

Download from the CBSC, prepare to leave the site,
 5-3

download ROM and RAM code, G-2

Download/Enable MCCs, 3-37

Download/Enable MGLIs, 3-34

Duplexer, optional test equipment, 1-10

E

E1, isolate BTS from the E1 spans, 3-14

Enable CSMs & BDCs, 3-36

End LMF session, 5-4

Equipment Overview, 1-15

Equipment warm-up, 3-50

establish MMI communication, 3-27

Ethernet LAN
 interconnect diagram, 3-29
 transceiver, 1-7

Ethernet LAN termination, 2-3

Every test fails, Troubleshooting, RFDS, 6-26

F

Failure report generation, 4-20

FER, acceptance test, 4-19

Files
 calibration data file, BLO, 3-67
 intermediate file, 4-20

Filtronics, low IM Duplexer (Cm035–f2) or
 equivalent, optional test equipment, 1-10

Fluke, model 8062A with Y8134 test lead kit, test
 equipment, 1-9

Folder Structure Overview, 3-9

Frame, equipage preliminary operations, 2-1

FREQ Monitor Connector, CSM, 6-30

Frequency counter, optional test equipment, 1-10

G

Gain set point, C-1

Generating an ATP Report, 4-20

General optimization checklist, test data sheets, A-4

Gigatronics 8542B power meter, illustration, F-13

GLI Connector, 6-20

GLI Ethernet A and B Connections, 6-20

GLI LED Status Combinations, 6-31

GLI Pushbuttons and Connectors, 6-32

GLI2 Front Panel Operating Indicators, 6-32

GPIB, F-1, F-5, F-7
 cables, 1-8

GPS, receiver operation, test data sheets, A-5

GPS Initialization/Verification
 estimated position accuracy, 3-41
 surveyed position accuracy, 3-41

GPS satellite system, 3-37

Group Line Interface. *See* GLI

H

Hardware Requirements, 1-6

High Stability 10 MHz Rubidium Standard, optional
 test equipment, 1-11

High-impedance conductive wrist strap, required test
 equipment, 1-9

HP 83236A, F-5

HP 8921A/600 test set, 1-8

HP8921A, F-5

HSO Initialization/Verification, 3-38
Huber & Suhner, required test equipment, 1-9
HyperTerminal, Creating named HyperTerminal connection, 3-7
HyperTerminal , create named connection, 3-7

I

I and Q values, E-1
Initial HP8921A setup, F-14
Initial Installation of Boards/Modules, preliminary operations, 2-1
Initial power tests, test data sheets, A-3
Inter-frame cabling, when to optimize, B-1
Intermediate file, generate ATP file using, 4-20
IS-97 specification, E-1

L

LAN
 BTS frame interconnect, illustration, 3-29
 optional test equipment, 1-10
LAN connectors, external, 2-3
LAN termination, 2-3
LED Status Combinations for all Modules except GLI2 CSM BBX2 MCC24 MCC8E, 6-28
LFR, receiver operation, test data sheets, A-6
LMF, F-1, F-7
 BTS connection, 3-21
 logout procedure, 5-4
 platform requirements, 1-6
 remove from BTS, 5-4
 shut down UNIX, 5-4
 terminal, 1-6
 to BTS connection, 3-14, 3-15
 TX acceptance tests, 4-3
 view CDF information, 3-3
lmf Folder, 3-9
loads folder, 3-11
Local Maintenance Facility. *See LMF*
Log out
 of BTS, 5-4
 of LMF PC, 5-4

Logging Into a BTS, 3-23
Logging Out, 3-25
LORAN-C Initialization/Verification, 3-46
LPA errors, 6-9
LPA Module LED, 6-34
LPA Shelf LED Status Combinations, 6-34

M

Master Group Line Interface. *See MGLI*
MASTER LED, GLI, 6-31
MCC LED Status Combinations, 6-33
MMI common connections, 3-28
MMI Connector
 CSM, 6-30
 GLI, 6-32
MMI Connectors, MCC, 6-33
MMI equipment setup, 3-28
Module status indicators, 6-28
Multi Channel Card. *See MCC*
Multi-FER test Failure, 6-17

N

New installations, 1-4
No AMR control, 6-22
No BBX2 control in the shelf, 6-23
No DC input voltage to Power Supply Module, 6-24
No DC voltage +5 +65 or +15 Volts to a specific GLI2 BBX2 or Switch board, 6-25
No GLI2 Control through span line connection, 6-22
No GLI2 Control via LMF, 6-21
No or missing MCC24 channel elements, 6-23
No or missing span line traffic, 6-23
North American, cellular telephone system frequency spectrum, CDMA allocation, D-4

O

Online Help, 3-28
Optional test equipment, 1-10
 10 MHz rubidium standard, 1-11
 2-way splitter, 1-10

CDMA subscriber mobile or portable
radiotelephone, 1-11
duplexer, 1-10
frequency counter, 1-10
LAN tester, 1-10
oscilloscope, 1-10
RF circular, 1-11
RF test cable, 1-10
spectrum analyzer, 1-10
Oscilloscope, optional test equipment, 1-10

P

PCMCIA, Ethernet adapter
LMF to BTS connection, 3-21
remove from BTS, 5-4
Periodic optimization, 1-4
Pilot Time Offset. *See* PN
Pilot time offset, acceptance test, 4-13
Ping, 3-29
PN
offset programming information, E-1
offset usage, E-1
PN offset per sector, E-1
PN Offset Usage , E-1
Power Input, 6-20
Power Meter
illustration, F-10
Pre-calibration, F-10
Power meter
calibration, Gigatronics 8542B, F-12
illustration, Gigatronics 8542B, F-13
required test equipment, 1-8
TX acceptance tests, 4-3
Power Supply Module Interface, 6-20
Pre-calibration, Power Meter, F-10
Pre-power tests, test data sheets, A-3
Preliminary operations
cell Site types, 2-1
test data sheets, A-2
Prepare to leave site
connect BTS E1/T1 spans, 5-5
connect BTS T1/E1 spans, 5-5
remove external test equipment, 5-3

Prepare to leave the site
bringing modules into service, 5-3
download code and data from CBSC, 5-3
Prerequisites, automated acceptance tests, 4-2
Procedures to Copy CAL Files From Diskette to the
CBSC, 5-1, 6-2, 6-5, 6-6, 6-7
Procedures to Copy Files to a Diskette, 5-1
Program, TSU NAM, 3-85
Pseudorandom Noise. *See* PN
PWR/ALM and ACTIVE LEDs, MCC, 6-33
PWR/ALM LED
BBX2, 6-33
CSM, 6-29
DC/DC Converter, 6-28
generic, 6-28
MCC, 6-33

R

RAM code, described, 3-32
Report generation, ATP report, 4-20
Required test equipment
communications system analyzer, 1-6, 1-8
digital multimeter, 1-9
directional coupler, 1-9
Ethernet LAN transceiver, 1-7
GPIB cables, 1-8
high-impedance conductive wrist strap, 1-9
power meter, 1-8
RF adapters, 1-9
RF attenuator, 1-9
RF load, 1-9
RS232 to GPIB interface, 1-7
timing reference cables, 1-9
Required test equipment and software, list, 1-6
RESET Pushbutton, GLI, 6-32
RF
attenuator, 1-9
Circular – optional test equipment, 1-11
load for required test equipment, 1-9
required test equipment load, 1-9
test cable, 1-9
RF path, fault isolation, 6-12
RF Path Bay Level Offset Calibration, 3-65
RFDS – Fault Isolation, 6-26
RFDS Calibration, 3-83

Index – continued

RFDS Location, SC 4812ET, 1-25
RFDS Test Subscriber Unit, 3-33
RFDS TSU Calibration Channel Frequencies, 3-83
Rho
 TX waveform quality acceptance test, 4-12
 waveform quality requirements, 4-12
ROM code
 described, 3-32
 downloading, G-1
ROM code download Caution, G-1
ROM code release level Caution, G-2
RS232 to GPIB interface
 modifications required for Automated Testing, 1-7
 required test equipment, 1-7
RX
 acceptance tests, FER, 4-18
 antenna VSWR, test data sheets, A-11
 sensitivity/frame error rate, 4-8
RX and TX paths fail, Troubleshooting, RFDS, 6-26

S

SC 4812 BTS Optimization/ATP Test Matrix, B-3
SCCP Backplane Troubleshooting, Procedure, 6-21
SCLPA, convergence test data sheets, A-7
Selecting Test Equipment, 3-57
Set Antenna Map Data, 3-81
Set RFDS Configuration Data, 3-82
Setting Cable Loss Values, 3-63
Setting Control Port, 3-15
Setting TX Coupler Loss Value, 3-64
SIF, output considerations vs BBX gain set point, C-1
Site, equipage verification, 3-3
Site checklist, verification data sheets, A-2
Site documents, 1-12
site equipage, CDF file, 3-2
Site expansion, 1-4
Span line
 T1/E1 verification equipment, 1-10
 troubleshooting, 6-35

Span line configuration, troubleshooting, 6-36
Span Line connector , 6-20
SPANS LED, 6-31
Spectral purity, TX mask – primary and redundant
 BBX, 4-7
Spectral purity transmit mask, acceptance test, 4-10
Spectrum analyzer, optional test equipment, 1-10
STATUS LED, GLI, 6-31
Supported Test Sets, 3-48
SYNC Monitor Connector, CSM, 6-30
System Connectivity Test, F-5

T

T1, isolate BTS from the T1 spans, 3-14
Tektronics model 2445 test equipment, 1-10
Test data sheets
 Alarm verification, A-11
 general optimization checklist, A-4
 GPS receiver operation, A-5
 initial power tests, A-3
 LFR receiver operation, A-6
 pre-power tests, A-3
 preliminary operations, A-2
 RX antenna VSWR, A-11
 SCLPA convergence, A-7
 site checklist, A-2
 TX antenna VSWR, A-10
 TX BLO, A-8
 verification of test equipment used, A-1
Test equipment
 See also Optional test equipment; Required test equipment
 set up, TX output verification/control, 4-3
 system analyzer, 1-8
 TX acceptance tests, 4-3
 verification data sheets, A-1
Test equipment connections , F-1
Test Equipment Setup, 3-48
Test Equipment Setup Calibration for TX Bay Level
 Offset, 3-62, F-18
Test Equipment Setup Chart, 3-49
Test equipment setup RF path calibration, 3-69
Test Set Calibration, 3-56

Timing reference cables, required test equipment
 Model SGLN1145A/4132A CSMs, 1-9
 Model SGLN4132B CSMs, 1-9

Transmit TX path audit, 3-74

Transmit TX path calibration, 3-70

Troubleshooting
 DC Power Problems, 6-24
 RF path fault isolation, 6-12
 Set span configuration, 6-36
 span problems, 6-35
 TX and RX Signal Routing, 6-25
 TX level accuracy fault isolation, 6-14

Troubleshooting CSM Checklist, 6-18

TX
 acceptance tests
 code domain power/noise floor, 4-15
 equipment setup, 4-3
 pilot time offset, 4-13
 spectral purity mask, 4-9
 spectrum analyzer display, 4-11
 waveform quality (rho), 4-12
 all inclusive TX ATP test, 4-4
 antenna VSWR, test data sheets, A-10, A-11
 BLO test data sheets, A-8
 level accuracy fault isolation, 6-14
 output acceptance tests
 code domain power noise, 4-7
 pilot time offset, 4-7
 waveform quality, 4-7

TX & RX Path Calibration, 3-65

TX and RX Frequency vs Channel , D-2

TX and RX Signal Routing, C-CCP Backplane
 Troubleshooting, 6-25

TX Audit Test, 3-75

TX Bay Level Offset and TX ATP test equipment
 setup calibration, 3-61

TX Calibration Test, 3-72

tx fine adjust, E-1

TX Path Calibration, 3-66

TX/RX OUT Connections, 4-2

U

UNIX, shut down on LMF, 5-4

Unshielded Twisted Pair. *See* UTP

Updating CDMA LMF Files, 5-1

UTP, LMF to BTS connection, 3-21

V

Verify
 test equipment used, test data sheets, A-1
 TX output, 4-3

Verify GLI ROM code load, 3-33

version Folder, 3-11

Virtual BTS, 1-15

W

Waveform quality (Rho), acceptance test procedure,
 4-12

When to optimize
 BTS, B-1
 inter-frame cabling, B-1

X

XCVR Backplane Troubleshooting, 6-20

Xircom Model PE3-10B2
 LMF to BTS connection, 3-21
 remove from BTS, 5-4

1X SC™ 4812ET Lite BTS Optimization/ATP

Software Release 2.16.0.x and CDMA LMF Build 2.16.x.x

800 MHz and 1900 MHz

CDMA

1X SC™ 4812ET Lite BTS Optimization/ATP
Software Release 2.16.0.x and CDMA LMF Build 2.16.x.x
800 MHz and 1900 MHz
CDMA

PRELIMINARY

English
08/01/2001
68P09253A60-1

