

Calculating 1900 MHz Center Frequencies

Table D-1 shows selected 1900 MHz CDMA candidate operating channels, listed in both decimal and hexadecimal, and the corresponding transmit, and receive frequencies. Center frequencies (in MHz) for channels not shown in the table may be calculated as follows:

- $TX = 1930 + 0.05 * \text{Channel\#}$
Example: Channel 262
 $TX = 1930 + 0.05 * 262 = 1943.10 \text{ MHz}$
- $RX = TX - 80$
Example: Channel 262
 $RX = 1943.10 - 80 = 1863.10 \text{ MHz}$

Actual frequencies used depend on customer CDMA system frequency plan.

Each CDMA channel requires a 1.77 MHz frequency segment. The actual CDMA carrier is 1.23 MHz wide, with a 0.27 MHz guard band on both sides of the carrier.

Minimum frequency separation required between any CDMA carrier and the nearest NAMPS/AMPS carrier is 900 kHz (center-to-center).

Table D-1: 1900 MHz TX and RX Frequency vs. Channel

Channel Number Decimal	Hex	Transmit Frequency (MHz) Center Frequency	Receive Frequency (MHz) Center Frequency
25	0019	1931.25	1851.25
50	0032	1932.50	1852.50
75	004B	1933.75	1853.75
100	0064	1935.00	1855.00
125	007D	1936.25	1856.25
150	0096	1937.50	1857.50
175	00AF	1938.75	1858.75
200	00C8	1940.00	1860.00
225	00E1	1941.25	1861.25
250	00FA	1942.50	1862.50
275	0113	1943.75	1863.75
300	012C	1945.00	1865.00
325	0145	1946.25	1866.25
350	015E	1947.50	1867.50
375	0177	1948.75	1868.75
400	0190	1950.00	1870.00
425	01A9	1951.25	1871.25
450	01C2	1952.50	1872.50
475	01DB	1953.75	1873.75
500	01F4	1955.00	1875.00
525	020D	1956.25	1876.25
550	0226	1957.50	1877.50
575	023F	1958.75	1878.75
600	0258	1960.00	1880.00
625	0271	1961.25	1881.25
650	028A	1962.50	1882.50

... continued on next page

Table D-1: 1900 MHz TX and RX Frequency vs. Channel

Channel Number		Transmit Frequency (MHz) Center Frequency	Receive Frequency (MHz) Center Frequency
Decimal	Hex		
675	02A3	1963.75	1883.75
700	02BC	1965.00	1885.00
725	02D5	1966.25	1886.25
750	02EE	1967.50	1887.50
775	0307	1968.75	1888.75
800	0320	1970.00	1890.00
825	0339	1971.25	1891.25
850	0352	1972.50	1892.50
875	036B	1973.75	1893.75
900	0384	1975.00	1895.00
925	039D	1976.25	1896.25
950	03B6	1977.50	1897.50
975	03CF	1978.75	1898.75
1000	03E8	1980.00	1900.00
1025	0401	1981.25	1901.25
1050	041A	1982.50	1902.50
1075	0433	1983.75	1903.75
1100	044C	1985.00	1905.00
1125	0465	1986.25	1906.25
1150	047E	1987.50	1807.50
1175	0497	1988.75	1908.75

D

800 MHz CDMA Channels

Figure D-2 shows the valid channels for the North American cellular telephone frequency spectrum. There are 10 CDMA wireline or non-wireline band channels used in a CDMA system (unique per customer operating system).

Figure D-2: North American Cellular Telephone System Frequency Spectrum (CDMA Allocation).

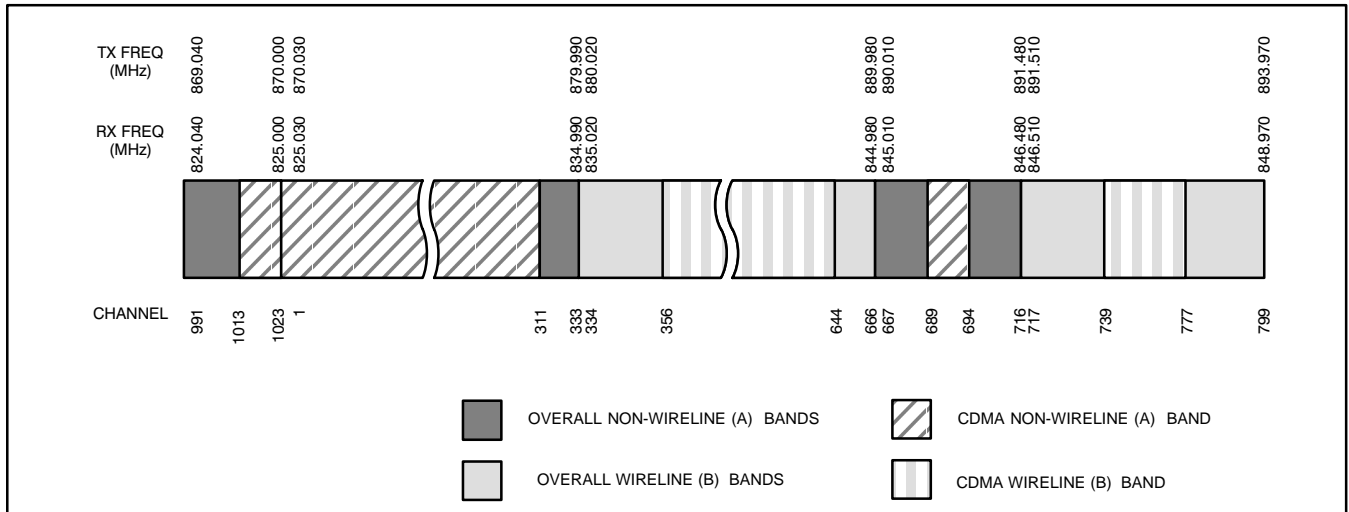

FW00402

Calculating 800 MHz Center Frequencies

Table D-2 shows selected 800 MHz CDMA candidate operating channels, listed in both decimal and hexadecimal, and the corresponding transmit, and receive frequencies. Center frequencies (in MHz) for channels not shown in the table may be calculated as follows:

- Channels 1-777
 $TX = 870 + 0.03 * Channel\#$
Example: Channel 262
 $TX = 870 + 0.03 * 262 = 877.86 \text{ MHz}$
- Channels 1013-1023
 $TX = 870 + 0.03 * (Channel\# - 1023)$
Example: Channel 1015
 $TX = 870 + 0.03 * (1015 - 1023) = 869.76 \text{ MHz}$
- $RX = TX - 45 \text{ MHz}$
Example: Channel 262
 $RX = 877.86 - 45 = 832.86 \text{ MHz}$

Channel Number		Transmit Frequency (MHz)	Receive Frequency (MHz)
Decimal	Hex	Center Frequency	Center Frequency
1	0001	870.0300	825.0300
25	0019	870.7500	825.7500
50	0032	871.5000	826.5000

... continued on next page

Table D-2: 800 MHz TX and RX Frequency vs. Channel

Channel Number		Transmit Frequency (MHz) Center Frequency	Receive Frequency (MHz) Center Frequency
Decimal	Hex		
75	004B	872.2500	827.2500
100	0064	873.0000	828.0000
125	007D	873.7500	828.7500
150	0096	874.5000	829.5000
175	00AF	875.2500	830.2500
200	00C8	876.0000	831.0000
225	00E1	876.7500	831.7500
250	00FA	877.5000	832.5000
275	0113	878.2500	833.2500
300	012C	879.0000	834.0000
325	0145	879.7500	834.7500
350	015E	880.5000	835.5000
375	0177	881.2500	836.2500
400	0190	882.0000	837.0000
425	01A9	882.7500	837.7500
450	01C2	883.5000	838.5000
475	01DB	884.2500	839.2500
500	01F4	885.0000	840.0000
525	020D	885.7500	840.7500
550	0226	886.5000	841.5000
575	023F	887.2500	842.2500
600	0258	888.0000	843.0000
625	0271	888.7500	843.7500
650	028A	889.5000	844.5000
675	02A3	890.2500	845.2500
700	02BC	891.0000	846.0000
725	02D5	891.7500	846.7500
750	02EE	892.5000	847.5000
775	0307	893.2500	848.2500
NOTE			
Channel numbers 778 through 1012 are not used.			
1013	03F5	869.7000	824.7000
1023	03FF	870.0000	825.0000

D

Appendix E

PN Offset/I & Q Offset Register Programming Information

■
E
■

PN Offset Programming Information

PN Offset Background

All channel elements transmitted from a BTS in a particular 1.25 MHz CDMA channel are orthonogonally spread by 1 of 64 possible Walsh code functions; additionally, they are also spread by a quadrature pair of PN sequences unique to each sector.

Overall, the mobile uses this to differentiate multiple signals transmitted from the same BTS (and surrounding BTS) sectors, and to synchronize to the next strongest sector.

The PN offset per sector is stored on the BBXs, where the corresponding I & Q registers reside.

The PN offset values are determined by BTS sector (antenna) based on the applicale CDF data field content. A breakdown of this information is found in Table E-1.

PN Offset Usage

There are three basic RF chip delays currently in use. It is important to determine what RF chip delay is valid to be able to test the BTS functionality. This can be done by ascertaining if the CDF `FineTxAdj` value was set to “on” when the MCC was downloaded with “image data”. The `FineTxAdj` value is used to compensate for the processing delay (approximately 20 μ S) in the BTS using any type of mobile meeting IS-97 specifications.

Observe the following guidelines:

- If the `FineTxAdj` value in the CDF is 101 (65 HEX), the `FineTxAdj` has not been set. The I and Q values from the 0 table **MUST** be used.

If the `FineTxAdj` value in the cdf file is 213 (D5 HEX), `FineTxAdj` has been set for the *14 chip table*.

- If the `FineTxAdj` value in the CDF file is 197 (C5 HEX), `FineTxAdj` has been set for the *13 chip table*.

NOTE CDF file I and Q values can be represented in DECIMAL or HEX. If using HEX, add 0x before the HEX value. If necessary, convert HEX values in Table E-1 to decimal before comparing them to cdf file I & Q value assignments.

- If a Qualcomm mobile is used, select I and Q values from the 13 chip delay table.
- If a mobile is used that does not have the 1 chip offset problem, (any mobile meeting the IS-97 specification), select from the 14 chip delay table.

NOTE If the wrong I and Q values are used with the wrong `FineTxAdj` parameter, system timing problems will occur. This will cause the energy transmitted to be “smeared” over several Walsh codes (instead of the single Walsh code that it was assigned to), causing erratic operation. Evidence of smearing is usually identified by Walsh channels not at correct levels or present when not selected in the Code Domain Power Test.



Table E-1: PnMaskI and PnMaskQ Values for PilotPn

Pilot PN	14-Chip Delay				13-Chip Delay				0-Chip Delay			
	I (Dec.)	Q	I (Hex.)	Q	I (Dec.)	Q	I (Hex.)	Q	I (Dec.)	Q	I (Hex.)	Q
0	17523	23459	4473	5BA3	29673	25581	73E9	63ED	4096	4096	1000	1000
1	32292	32589	7E24	7F4D	16146	29082	3F12	719A	9167	1571	23CF	0623
2	4700	17398	125C	43F6	2350	8699	092E	21FB	22417	7484	5791	1D3C
3	14406	26333	3846	66DD	7203	32082	1C23	7D52	966	6319	03C6	18AF
4	14899	4011	3A33	0FAB	19657	18921	4CC9	49E9	14189	2447	376D	098F
5	17025	2256	4281	08D0	28816	1128	7090	0468	29150	24441	71DE	5F79
6	14745	18651	3999	48DB	19740	27217	4D1C	6A51	18245	27351	4745	6AD7
7	2783	1094	0ADF	0446	21695	547	54BF	0223	1716	23613	06B4	5C3D
8	5832	21202	16C8	52D2	2916	10601	0B64	2969	11915	29008	2E8B	7150
9	12407	13841	3077	3611	18923	21812	49EB	5534	20981	5643	51F5	160B
10	31295	31767	7A3F	7C17	27855	28727	6CCF	7037	24694	28085	6076	6DB5
11	7581	18890	1D9D	49CA	24350	9445	5F1E	24E5	11865	18200	2E59	4718
12	18523	30999	485B	7917	30205	29367	75FD	72B7	6385	21138	18F1	5292
13	29920	22420	74E0	5794	14960	11210	3A70	2BCA	27896	21937	6CF8	55B1
14	25184	20168	6260	4EC8	12592	10084	3130	2764	25240	25222	6298	6286
15	26282	12354	66AA	3042	13141	6177	3355	1821	30877	109	789D	006D
16	30623	11187	779F	2BB3	27167	23525	6A1F	5BE5	30618	6028	779A	178C
17	15540	11834	3CB4	2E3A	7770	5917	1E5A	171D	26373	22034	6705	5612
18	23026	10395	59F2	289B	11513	23153	2CF9	5A71	314	15069	013A	3ADD
19	20019	28035	4E33	6D83	30409	30973	76C9	78FD	17518	4671	446E	123F
20	4050	27399	0FD2	6B07	2025	31679	07E9	7BBF	21927	30434	55A7	76E2
21	1557	22087	0615	5647	21210	25887	52DA	651F	2245	11615	08C5	2D5F
22	30262	2077	7636	081D	15131	18994	3B1B	4A32	18105	19838	46B9	4D7E
23	18000	13758	4650	35BE	9000	6879	2328	1ADF	8792	14713	2258	3979
24	20056	11778	4E58	2E02	10028	5889	272C	1701	21440	241	53C0	00F1
25	12143	3543	2F6F	0DD7	18023	18647	4667	48D7	15493	24083	3C85	5E13
26	17437	7184	441D	1C10	29662	3592	73DE	0E08	26677	7621	6835	1DC5
27	17438	2362	441E	093A	8719	1181	220F	049D	11299	19144	2C23	4AC8
28	5102	25840	13EE	64F0	2551	12920	09F7	3278	12081	1047	2F31	0417
29	9302	12177	2456	2F91	4651	23028	122B	59F4	23833	26152	5D19	6628
30	17154	10402	4302	28A2	8577	5201	2181	1451	20281	22402	4F39	5782
31	5198	1917	144E	077D	2599	19842	0A27	4D82	10676	21255	29B4	5307
32	4606	17708	11FE	452C	2303	8854	08FF	2296	16981	30179	4255	75E3
33	24804	10630	60E4	2986	12402	5315	3072	14C3	31964	7408	7CDC	1CF0
34	17180	6812	431C	1A9C	8590	3406	218E	0D4E	26913	115	6921	0073
35	10507	14350	290B	380E	17749	7175	4555	1C07	14080	1591	3700	0637
36	10157	10999	27AD	2AF7	16902	23367	4206	5B47	23842	1006	5D22	03EE
37	23850	25003	5D2A	61AB	11925	32489	2E95	7EE9	27197	32263	6A3D	7E07
38	31425	2652	7AC1	0A5C	27824	1326	6CB0	052E	22933	1332	5995	0534
39	4075	19898	0FEB	4DBA	22053	9949	5625	26DD	30220	12636	760C	315C
40	10030	2010	272E	07DA	5015	1005	1397	03ED	12443	4099	309B	1003
41	16984	25936	4258	6550	8492	12968	212C	32A8	19854	386	4D8E	0182
42	14225	28531	3791	6F73	18968	31109	4A18	7985	14842	29231	39FA	722F
43	26519	11952	6797	2EB0	25115	5976	621B	1758	15006	25711	3A9E	646F
44	27775	31947	6C7F	7CCB	26607	28761	67EF	7059	702	10913	02BE	2AA1
45	30100	25589	7594	63F5	15050	32710	3ACA	7FC6	21373	8132	537D	1FC4
46	7922	11345	1EF2	2C51	3961	22548	0F79	5814	23874	20844	5D42	516C
47	14199	28198	3777	6E26	19051	14099	4A6B	3713	3468	13150	0D8C	335E
48	17637	13947	44E5	367B	29602	21761	73A2	5501	31323	18184	7A5B	4708
49	23081	8462	5A29	210E	31940	4231	7CC4	1087	29266	19066	7252	4A7A
50	5099	9595	13EB	257B	22565	23681	5825	5C81	16554	29963	40AA	750B

... continued on next page



Table E-1: PnMaskI and PnMaskQ Values for PilotPn

Pilot PN	14-Chip Delay				13-Chip Delay				0-Chip Delay			
	I (Dec.)	Q	I (Hex.)	Q	I (Dec.)	Q	I (Hex.)	Q	I (Dec.)	Q	I (Hex.)	Q
51	32743	4670	7FE7	123E	28195	2335	6E23	091F	22575	6605	582F	19CD
52	7114	14672	1BCA	3950	3557	7336	0DE5	1CA8	31456	29417	7AE0	72E9
53	7699	29415	1E13	72E7	24281	30543	5ED9	774F	8148	22993	1FD4	59D1
54	19339	20610	4B8B	5082	29717	10305	7415	2841	19043	27657	4A63	6C09
55	28212	6479	6E34	194F	14106	17051	371A	429B	25438	5468	635E	155C
56	29587	10957	7393	2ACD	26649	23386	6819	5B5A	10938	8821	2ABA	2275
57	19715	18426	4D03	47FA	30545	9213	7751	23FD	2311	20773	0907	5125
58	14901	22726	3A35	58C6	19658	11363	4CCA	2C63	7392	4920	1CE0	1338
59	20160	5247	4EC0	147F	10080	17411	2760	4403	30714	5756	77FA	167C
60	22249	29953	56E9	7501	31396	29884	7AA4	74BC	180	28088	00B4	6DB8
61	26582	5796	67D6	16A4	13291	2898	33EB	0B52	8948	740	22F4	02E4
62	7153	16829	1BF1	41BD	23592	28386	5C28	6EE2	16432	23397	4030	5B65
63	15127	4528	3B17	11B0	19547	2264	4C5B	08D8	9622	19492	2596	4C24
64	15274	5415	3BAA	1527	7637	17583	1DD5	44AF	7524	26451	1D64	6753
65	23149	10294	5A6D	2836	31974	5147	7CE6	141B	1443	30666	05A3	77CA
66	16340	17046	3FD4	4296	8170	8523	1FEA	214B	1810	15088	0712	3AF0
67	27052	7846	69AC	1EA6	13526	3923	34D6	0F53	6941	26131	1B1D	6613
68	13519	10762	34CF	2A0A	19383	5381	4BB7	1505	3238	15969	0CA6	3E61
69	10620	13814	297C	35F6	5310	6907	14BE	1AFB	8141	24101	1FCD	5E25
70	15978	16854	3E6A	41D6	7989	8427	1F35	20EB	10408	12762	28A8	31DA
71	27966	795	6D3E	031B	13983	20401	369F	4FB1	18826	19997	498A	4E1D
72	12479	9774	30BF	262E	18831	4887	498F	1317	22705	22971	58B1	59BB
73	1536	24291	0600	5EE3	768	24909	0300	614D	3879	12560	0F27	3110
74	3199	3172	0C7F	0C64	22511	1586	57EF	0632	21359	31213	536F	79ED
75	4549	2229	11C5	08B5	22834	19046	5932	4A66	30853	18780	7885	495C
76	17888	21283	45E0	5323	8944	26541	22F0	67AD	18078	16353	469E	3FE1
77	13117	16905	333D	4209	18510	28472	484E	6F38	15910	12055	3E26	2F17
78	7506	7062	1D52	1B96	3753	3531	0EA9	0DCB	20989	30396	51FD	76BC
79	27626	7532	6BEA	1D6C	13813	3766	35F5	0EB6	28810	24388	708A	5F44
80	31109	25575	7985	63E7	27922	32719	6D12	7FCF	30759	1555	7827	0613
81	29755	14244	743B	37A4	27597	7122	6BCD	1BD2	18899	13316	49D3	3404
82	26711	28053	6857	6D95	26107	30966	65FB	78F6	7739	31073	1E3B	7961
83	20397	30408	4FAD	76C8	30214	15204	7606	3B64	6279	6187	1887	182B
84	18608	5094	48B0	13E6	9304	2547	2458	09F3	9968	21644	26F0	548C
85	7391	16222	1CDF	3F5E	24511	8111	5FBF	1FAF	8571	9289	217B	2449
86	23168	7159	5A80	1BF7	11584	17351	2D40	43C7	4143	4624	102F	1210
87	23466	174	5BAA	00AE	11733	87	2DD5	0057	19637	467	4CB5	01D3
88	15932	25530	3E3C	63BA	7966	12765	1F1E	31DD	11867	18133	2E5B	46D5
89	25798	2320	64C6	0910	12899	1160	3263	0488	7374	1532	1CCE	05FC
90	28134	23113	6DE6	5A49	14067	25368	36F3	6318	10423	1457	28B7	05B1
91	28024	23985	6D78	5DB1	14012	24804	36BC	60E4	9984	9197	2700	23ED
92	6335	2604	18BF	0A2C	23951	1302	5D8F	0516	7445	13451	1D15	348B
93	21508	1826	5404	0722	10754	913	2A02	0391	4133	25785	1025	64B9
94	26338	30853	66E2	7885	13169	29310	3371	727E	22646	4087	5876	0FF7
95	17186	15699	4322	3D53	8593	20629	2191	5095	15466	31190	3C6A	79D6
96	22462	2589	57BE	0A1D	11231	19250	2BDF	4B32	2164	8383	0874	20BF
97	3908	25000	0F44	61A8	1954	12500	07A2	30D4	16380	12995	3FFC	32C3
98	25390	18163	632E	46F3	12695	27973	3197	6D45	15008	27438	3AA0	6B2E
99	27891	12555	6CF3	310B	26537	22201	67A9	56B9	31755	9297	7C0B	2451
100	9620	8670	2594	21DE	4810	4335	12CA	10EF	31636	1676	7B94	068C

... continued on next page

Table E-1: PnMaskI and PnMaskQ Values for PilotPn

Pilot PN	14-Chip Delay				13-Chip Delay				0-Chip Delay			
	I (Dec.)	Q (Dec.)	I (Hex.)	Q (Hex.)	I (Dec.)	Q (Dec.)	I (Hex.)	Q (Hex.)	I (Dec.)	Q (Dec.)	I (Hex.)	Q (Hex.)
101	6491	1290	195B	050A	23933	645	5D7D	0285	25414	12596	6346	3134
102	16876	4407	41EC	1137	8438	18087	20F6	46A7	7102	19975	1BBE	4E07
103	17034	1163	428A	048B	8517	19577	2145	4C79	20516	20026	5024	4E3A
104	32405	12215	7E95	2FB7	28314	23015	6E9A	59E7	19495	8958	4C27	22FE
105	27417	7253	6B19	1C55	25692	16406	645C	4016	17182	19143	431E	4AC7
106	8382	8978	20BE	2312	4191	4489	105F	1189	11572	17142	2D34	42F6
107	5624	25547	15F8	63CB	2812	32729	0AFC	7FD9	25570	19670	63E2	4CD6
108	1424	3130	0590	0C3A	712	1565	02C8	061D	6322	30191	18B2	75EF
109	13034	31406	32EA	7AAE	6517	15703	1975	3D57	8009	5822	1F49	16BE
110	15682	6222	3D42	184E	7841	3111	1EA1	0C27	26708	22076	6854	563C
111	27101	20340	69DD	4F74	25918	10170	653E	27BA	6237	606	185D	025E
112	8521	25094	2149	6206	16756	12547	4174	3103	32520	9741	7F08	260D
113	30232	23380	7618	5B54	15116	11690	3B0C	2DAA	31627	9116	7B8B	239C
114	6429	10926	191D	2AAE	23902	5463	5D5E	1557	3532	12705	0DCC	31A1
115	27116	22821	69EC	5925	13558	25262	34F6	62AE	24090	17502	5E1A	445E
116	4238	31634	108E	7B92	2119	15817	0847	3DC9	20262	18952	4F26	4A08
117	5128	4403	1408	1133	2564	18085	0A04	46A5	18238	15502	473E	3C8E
118	14846	689	39FE	02B1	7423	20324	1CFF	4F64	2033	17819	07F1	459B
119	13024	27045	32E0	69A5	6512	31470	1970	7AEE	25566	4370	63DE	1112
120	10625	27557	2981	6BA5	17680	31726	4510	7BEE	25144	31955	6238	7CD3
121	31724	16307	7BEC	3FB3	15862	20965	3DF6	51E5	29679	30569	73EF	7769
122	13811	22338	35F3	5742	19241	11169	4B29	2BA1	5064	7350	13C8	1CB6
123	24915	27550	6153	6B9E	24953	13775	6179	35CF	27623	26356	6BE7	66F4
124	1213	22096	04BD	5650	21390	11048	538E	2B28	13000	32189	32C8	7DBD
125	2290	23136	08F2	5A60	1145	11568	0479	2D30	31373	1601	7A8D	0641
126	31551	12199	7B3F	2FA7	27727	23023	6C4F	59EF	13096	19537	3328	4C51
127	12088	1213	2F38	04BD	6044	19554	179C	4C62	26395	25667	671B	6443
128	7722	936	1E2A	03A8	3861	468	0F15	01D4	15487	4415	3C7F	113F
129	27312	6272	6AB0	1880	13656	3136	3558	0C40	29245	2303	723D	08FF
130	23130	32446	5A5A	7EBE	11565	16223	2D2D	3F5F	26729	16362	6869	3FEA
131	594	13555	0252	34F3	297	21573	0129	5445	12568	28620	3118	6FCC
132	25804	8789	64CC	2255	12902	24342	3266	5F16	24665	6736	6059	1A50
133	31013	24821	7925	60F5	27970	32326	6D42	7E46	8923	2777	22DB	0AD9
134	32585	21068	7F49	524C	28276	10534	6E74	2926	19634	24331	4CB2	5F0B
135	3077	31891	0C05	7C93	22482	28789	57D2	7075	29141	9042	71D5	2352
136	17231	5321	434F	14C9	28791	17496	7077	4458	73	107	0049	006B
137	31554	551	7B42	0227	15777	20271	3DA1	4F2F	26482	4779	6772	12AB
138	8764	12115	223C	2F53	4382	22933	111E	5995	6397	13065	18FD	3309
139	15375	4902	3C0F	1326	20439	2451	4FD7	0993	29818	30421	747A	76D5
140	13428	1991	3474	07C7	6714	19935	1A3A	4DDF	8153	20210	1FD9	4EF2
141	17658	14404	44FA	3844	8829	7202	227D	1C22	302	5651	012E	1613
142	13475	17982	34A3	463E	19329	8991	4B81	231F	28136	31017	6DE8	7929
143	22095	19566	564F	4C6E	31479	9783	7AF7	2637	29125	30719	71C5	77FF
144	24805	2970	60E5	0B9A	24994	1485	61A2	05CD	8625	23104	21B1	5A40
145	4307	23055	10D3	5A0F	22969	25403	59B9	633B	26671	7799	682F	1E77
146	23292	15158	5AFC	3B36	11646	7579	2D7E	1D9B	6424	17865	1918	45C9
147	1377	29094	0561	71A6	21344	14547	5360	38D3	12893	26951	325D	6947
148	28654	653	6FEE	028D	14327	20346	37F7	4F7A	18502	25073	4846	61F1
149	6350	19155	18CE	4AD3	3175	27477	0C67	6B55	7765	32381	1E55	7E7D
150	16770	23588	4182	5C24	8385	11794	20C1	2E12	25483	16581	638B	40C5

... continued on next page



Table E-1: PnMaskI and PnMaskQ Values for PilotPn

Pilot PN	14-Chip Delay				13-Chip Delay				0-Chip Delay			
	I (Dec.)	Q	I (Hex.)	Q	I (Dec.)	Q	I (Hex.)	Q	I (Dec.)	Q	I (Hex.)	Q
151	14726	10878	3986	2A7E	7363	5439	1CC3	153F	15408	32087	3C30	7D57
152	25685	31060	6455	7954	25594	15530	63FA	3CAA	6414	97	190E	0061
153	21356	30875	536C	789B	10678	29297	29B6	7271	8164	7618	1FE4	1DC2
154	12149	11496	2F75	2CE8	18026	5748	466A	1674	10347	93	286B	005D
155	28966	24545	7126	5FE1	14483	25036	3893	61CC	29369	16052	72B9	3EB4
156	22898	9586	5972	2572	11449	4793	2CB9	12B9	10389	14300	2895	37DC
157	1713	20984	06B1	51F8	21128	10492	5288	28FC	24783	11129	60CF	2B79
158	30010	30389	753A	76B5	15005	30054	3A9D	7566	18400	6602	47E0	19CA
159	2365	7298	093D	1C82	21838	3649	554E	0E41	22135	14460	5677	387C
160	27179	18934	6A2B	49F6	25797	9467	64C5	24FB	4625	25458	1211	6372
161	29740	23137	742C	5A61	14870	25356	3A16	630C	22346	15869	574A	3DFD
162	5665	24597	1621	6015	23232	32310	5AC0	7E36	2545	27047	09F1	69A7
163	23671	23301	5C77	5B05	32747	25534	7FEB	63BE	7786	26808	1E6A	68B8
164	1680	7764	0690	1E54	840	3882	0348	0F2A	20209	7354	4EF1	1CBA
165	25861	14518	6505	38B6	25426	7259	6352	1C5B	26414	27834	672E	6CBA
166	25712	21634	6470	5482	12856	10817	3238	2A41	1478	11250	05C6	2BF2
167	19245	11546	4B2D	2D1A	29766	5773	7446	168D	15122	552	3B12	0228
168	26887	26454	6907	6756	25939	13227	6553	33AB	24603	27058	601B	69B2
169	30897	15938	78B1	3E42	28040	7969	6D88	1F21	677	14808	02A5	39D8
170	11496	9050	2CE8	235A	5748	4525	1674	11AD	13705	9642	3589	25AA
171	1278	3103	04FE	0C1F	639	18483	027F	4833	13273	32253	33D9	7DFD
172	31555	758	7B43	02F6	27761	379	6C71	017B	14879	26081	3A1F	65E1
173	29171	16528	71F3	4090	26921	8264	6929	2048	6643	21184	19F3	52C0
174	20472	20375	4FF8	4F97	10236	27127	27FC	69F7	23138	11748	5A62	2DE4
175	5816	10208	16B8	27E0	2908	5104	0B5C	13F0	28838	32676	70A6	7FA4
176	30270	17698	763E	4522	15135	8849	3B1F	2291	9045	2425	2355	0979
177	22188	8405	56AC	20D5	11094	24150	2B56	5E56	10792	19455	2A28	4BFF
178	6182	28634	1826	6FDA	3091	14317	0C13	37ED	25666	19889	6442	4DB1
179	32333	1951	7E4D	079F	28406	19955	6EF6	4DF3	11546	18177	2D1A	4701
180	14046	20344	36DE	4F78	7023	10172	1B6F	27BC	15535	2492	3CAF	09BC
181	15873	26696	3E01	6848	20176	13348	4ED0	3424	16134	15086	3F06	3AEE
182	19843	3355	4D83	0D1B	30481	18609	7711	48B1	8360	30632	20A8	77A8
183	29367	11975	72B7	2EC7	26763	22879	688B	595F	14401	27549	3841	6B9D
184	13352	31942	3428	7CC6	6676	15971	1A14	3E63	26045	6911	65BD	1AFF
185	22977	9737	59C1	2609	32048	23864	7D30	5D38	24070	9937	5E06	26D1
186	31691	9638	7BCB	25A6	27701	4819	6C35	12D3	30300	2467	765C	09A3
187	10637	30643	298D	77B3	17686	30181	4516	75E5	13602	25831	3522	64E7
188	25454	13230	636E	33AE	12727	6615	31B7	19D7	32679	32236	7FA7	7DEC
189	18610	22185	48B2	56A9	9305	25960	2459	6568	16267	12987	3F8B	32BB
190	6368	2055	18E0	0807	3184	19007	0C70	4A3F	9063	11714	2367	2DC2
191	7887	8767	1ECF	223F	24247	24355	5EB7	5F23	19487	19283	4C1F	4B53
192	7730	15852	1E32	3DEC	3865	7926	0F19	1EF6	12778	11542	31EA	2D16
193	23476	16125	5BB4	3EFD	11738	20802	2DDA	5142	27309	27928	6AAD	6D18
194	889	6074	0379	17BA	20588	3037	506C	0BDD	12527	26637	30EF	680D
195	21141	31245	5295	7A0D	30874	29498	789A	733A	953	10035	03B9	2733
196	20520	15880	5028	3E08	10260	7940	2814	1F04	15958	10748	3E56	29FC
197	21669	20371	54A5	4F93	31618	27125	7B82	69F5	6068	24429	17B4	5F6D
198	15967	8666	3E5F	21DA	20223	4333	4EFF	10ED	23577	29701	5C19	7405
199	21639	816	5487	0330	31635	408	7B93	0198	32156	14997	7D9C	3A95
200	31120	22309	7990	5725	15560	26030	3CC8	65AE	32709	32235	7FC5	7DEB

... continued on next page

Table E-1: PnMaskI and PnMaskQ Values for PilotPn

Pilot PN	14-Chip Delay				13-Chip Delay				0-Chip Delay			
	I (Dec.)	Q	I (Hex.)	Q	I (Dec.)	Q	I (Hex.)	Q	I (Dec.)	Q	I (Hex.)	Q
201	3698	29563	0E72	737B	1849	30593	0739	7781	23557	30766	5C05	782E
202	16322	13078	3FC2	3316	8161	6539	1FE1	198B	17638	5985	44E6	1761
203	17429	10460	4415	28DC	29658	5230	73DA	146E	3545	6823	0DD9	1AA7
204	21730	17590	54E2	44B6	10865	8795	2A71	225B	9299	20973	2453	51ED
205	17808	20277	4590	4F35	8904	27046	22C8	69A6	6323	10197	18B3	27D5
206	30068	19988	7574	4E14	15034	9994	3ABA	270A	19590	9618	4C86	2592
207	12737	6781	31C1	1A7D	18736	17154	4930	4302	7075	22705	1BA3	58B1
208	28241	32501	6E51	7EF5	26360	28998	66F8	7146	14993	5234	3A91	1472
209	20371	6024	4F93	1788	30233	3012	7619	0BC4	19916	12541	4DCC	30FD
210	13829	20520	3605	5028	19154	10260	4AD2	2814	6532	8019	1984	1F53
211	13366	31951	3436	7CCF	6683	28763	1A1B	705B	17317	22568	43A5	5828
212	25732	26063	6484	65CF	12866	31963	3242	7CDB	16562	5221	40B2	1465
213	19864	27203	4D98	6A43	9932	31517	26CC	7B1D	26923	25216	692B	6280
214	5187	6614	1443	19D6	23537	3307	5BF1	0CEB	9155	1354	23C3	054A
215	23219	10970	5AB3	2ADA	31881	5485	7C89	156D	20243	29335	4F13	7297
216	28242	5511	6E52	1587	14121	17663	3729	44FF	32391	6682	7E87	1A1A
217	6243	17119	1863	42DF	24033	28499	5DE1	6F53	20190	26128	4EDE	6610
218	445	16064	01BD	3EC0	20750	8032	510E	1F60	27564	29390	6BAC	72CE
219	21346	31614	5362	7B7E	10673	15807	29B1	3DBF	20869	8852	5185	2294
220	13256	4660	33C8	1234	6628	2330	19E4	091A	9791	6110	263F	17DE
221	18472	13881	4828	3639	9236	21792	2414	5520	714	11847	02CA	2E47
222	25945	16819	6559	41B3	25468	28389	637C	6EE5	7498	10239	1D4A	27FF
223	31051	6371	794B	18E3	28021	16973	6D75	424D	23278	6955	5AEE	1B2B
224	1093	24673	0445	6061	21490	32268	53F2	7E0C	8358	10897	20A6	2A91
225	5829	6055	16C5	17A7	23218	17903	5AB2	45EF	9468	14076	24FC	36FC
226	31546	10009	7B3A	2719	15773	23984	3D9D	5DB0	23731	12450	5CB3	30A2
227	29833	5957	7489	1745	27540	17822	6B94	459E	25133	8954	622D	22FA
228	18146	11597	46E2	2D4D	9073	22682	2371	589A	2470	19709	09A6	4CFD
229	24813	22155	60ED	568B	24998	25977	61A6	6579	17501	1252	445D	04E4
230	47	15050	002F	3ACA	20935	7525	51C7	1D65	24671	15142	605F	3B26
231	3202	16450	0C82	4042	1601	8225	0641	2021	11930	26958	2E9A	694E
232	21571	27899	5443	6CFB	31729	30785	7BF1	7841	9154	8759	23C2	2237
233	7469	2016	1D2D	07E0	24390	1008	5F46	03F0	7388	12696	1CDC	3198
234	25297	17153	62D1	4301	24760	28604	60B8	6FBC	3440	11936	0D70	2EA0
235	8175	15849	1FEF	3DE9	24103	20680	5E27	50C8	27666	25635	6C12	6423
236	28519	30581	6F67	7775	26211	30086	6663	7586	22888	17231	5968	434F
237	4991	3600	137F	0E10	22639	1800	586F	0708	13194	22298	338A	571A
238	7907	4097	1EE3	1001	24225	17980	5EA1	463C	26710	7330	6856	1CA2
239	17728	671	4540	029F	8864	20339	22A0	4F73	7266	30758	1C62	7826
240	14415	20774	384F	5126	19959	10387	4DF7	2893	15175	6933	3B47	1B15
241	30976	24471	7900	5F97	15488	25079	3C80	61F7	15891	2810	3E13	0AFA
242	26376	27341	6708	6ACD	13188	31578	3384	7B5A	26692	8820	6844	2274
243	19063	19388	4A77	4BBC	29931	9694	74EB	25DE	14757	7831	39A5	1E97
244	19160	25278	4AD8	62BE	9580	12639	256C	315F	28757	19584	7055	4C80
245	3800	9505	0ED8	2521	1900	23724	076C	5CAC	31342	2944	7A6E	0B80
246	8307	26143	2073	661F	16873	32051	41E9	7D33	19435	19854	4BEB	4D8E
247	12918	13359	3276	342F	6459	21547	193B	542B	2437	10456	0985	28D8
248	19642	2154	4CBA	086A	9821	1077	265D	0435	20573	17036	505D	428C
249	24873	13747	6129	35B3	24900	21733	6144	54E5	18781	2343	495D	0927
250	22071	27646	5637	6BFE	31435	13823	7ACB	35FF	18948	14820	4A04	39E4

... continued on next page



Table E-1: PnMaskI and PnMaskQ Values for PilotPn

Pilot PN	14-Chip Delay				13-Chip Delay				0-Chip Delay			
	I (Dec.)	Q	I (Hex.)	Q	I (Dec.)	Q	I (Hex.)	Q	I (Dec.)	Q	I (Hex.)	Q
251	13904	1056	3650	0420	6952	528	1B28	0210	23393	1756	5B61	06DC
252	27198	1413	6A3E	0585	13599	19710	351F	4CFE	5619	19068	15F3	4A7C
253	3685	3311	0E65	0CEF	22242	18507	56E2	484B	17052	28716	429C	702C
254	16820	4951	41B4	1357	8410	18327	20DA	4797	21292	31958	532C	7CD6
255	22479	749	57CF	02ED	31287	20298	7A37	4F4A	2868	16097	0B34	3EE1
256	6850	6307	1AC2	18A3	3425	17005	0D61	426D	19538	1308	4C52	051C
257	15434	961	3C4A	03C1	7717	20444	1E25	4FDC	24294	3320	5EE6	0CF8
258	19332	2358	4B84	0936	9666	1179	25C2	049B	22895	16682	596F	412A
259	8518	28350	2146	6EBE	4259	14175	10A3	375F	27652	6388	6C04	18F4
260	14698	31198	396A	79DE	7349	15599	1CB5	3CEF	29905	12828	74D1	321C
261	21476	11467	53E4	2CCB	10738	22617	29F2	5859	21415	3518	53A7	0DBE
262	30475	8862	770B	229E	27221	4431	6A55	114F	1210	3494	04BA	0DA6
263	23984	6327	5DB0	18B7	11992	16999	2ED8	4267	22396	6458	577C	193A
264	1912	7443	0778	1D13	956	16565	03BC	40B5	26552	10717	67B8	29DD
265	26735	28574	686F	6F9E	26087	14287	65E7	37CF	24829	8463	60FD	210F
266	15705	25093	3D59	6205	20348	32574	4F7C	7F3E	8663	27337	21D7	6AC9
267	3881	6139	0F29	17FB	22084	17857	5644	45C1	991	19846	03DF	4D86
268	20434	22047	4FD2	561F	10217	25907	27E9	6533	21926	9388	55A6	24AC
269	16779	32545	418B	7F21	28949	29100	7115	71AC	23306	21201	5B0A	52D1
270	31413	7112	7AB5	1BC8	27786	3556	6C8A	0DE4	13646	31422	354E	7ABE
271	16860	28535	41DC	6F77	8430	31111	20EE	7987	148	166	0094	00A6
272	8322	10378	2082	288A	4161	5189	1041	1445	24836	28622	6104	6FCE
273	28530	15065	6F72	3AD9	14265	21328	37B9	5350	24202	6477	5E8A	194D
274	26934	5125	6936	1405	13467	17470	349B	443E	9820	10704	265C	29D0
275	18806	12528	4976	30F0	9403	6264	24BB	1878	12939	25843	328B	64F3
276	20216	23215	4EF8	5AAF	10108	25451	277C	636B	2364	25406	093C	633E
277	9245	20959	241D	51DF	17374	26323	43DE	66D3	14820	21523	39E4	5413
278	8271	3568	204F	0DF0	16887	1784	41F7	06F8	2011	8569	07DB	2179
279	18684	26453	48FC	6755	9342	32150	247E	7D96	13549	9590	34ED	2576
280	8220	29421	201C	72ED	4110	30538	100E	774A	28339	22466	6EB3	57C2
281	6837	24555	1AB5	5FEB	23690	25033	5C8A	61C9	25759	12455	649F	30A7
282	9613	10779	258D	2A1B	17174	23345	4316	5B31	11116	27506	2B6C	6B72
283	31632	25260	7B90	62AC	15816	12630	3DC8	3156	31448	21847	7AD8	5557
284	27448	16084	6B38	3ED4	13724	8042	359C	1F6A	27936	28392	6D20	6EE8
285	12417	26028	3081	65AC	18832	13014	4990	32D6	3578	1969	0DFA	07B1
286	30901	29852	78B5	749C	28042	14926	6D8A	3A4E	12371	30715	3053	77FB
287	9366	14978	2496	3A82	4683	7489	124B	1D41	12721	23674	31B1	5C7A
288	12225	12182	2FC1	2F96	17968	6091	4630	17CB	10264	22629	2818	5865
289	21458	25143	53D2	6237	10729	32551	29E9	7F27	25344	12857	6300	3239
290	6466	15838	1942	3DDE	3233	7919	0CA1	1EEF	13246	30182	33BE	75E6
291	8999	5336	2327	14D8	16451	2668	4043	0A6C	544	21880	0220	5578
292	26718	21885	685E	557D	13359	25730	342F	6482	9914	6617	26BA	19D9
293	3230	20561	0C9E	5051	1615	26132	064F	6614	4601	27707	11F9	6C3B
294	27961	30097	6D39	7591	26444	29940	674C	74F4	16234	16249	3F6A	3F79
295	28465	21877	6F31	5575	26184	25734	6648	6486	24475	24754	5F9B	60B2
296	6791	23589	1A87	5C25	23699	24622	5C93	602E	26318	31609	66CE	7B79
297	17338	26060	43BA	65CC	8669	13030	21DD	32E6	6224	22689	1850	58A1
298	11832	9964	2E38	26EC	5916	4982	171C	1376	13381	3226	3445	0C9A
299	11407	25959	2C8F	6567	18327	31887	4797	7C8F	30013	4167	753D	1047
300	15553	3294	3CC1	0CDE	20400	1647	4FB0	066F	22195	25624	56B3	6418

... continued on next page

Table E-1: PnMaskI and PnMaskQ Values for PilotPn

Pilot PN	14-Chip Delay				13-Chip Delay				0-Chip Delay			
	I (Dec.)	Q	I (Hex.)	Q	I (Dec.)	Q	I (Hex.)	Q	I (Dec.)	Q	I (Hex.)	Q
301	17418	30173	440A	75DD	8709	29906	2205	74D2	30380	10924	76AC	2AAC
302	14952	15515	3A68	3C9B	7476	20593	1D34	5071	15337	23096	3BE9	5A38
303	52	5371	0034	14FB	26	17473	001A	4441	10716	22683	29DC	589B
304	27254	10242	6A76	2802	13627	5121	353B	1401	13592	10955	3518	2ACB
305	15064	28052	3AD8	6D9A	7532	14026	1D6C	36CA	2412	17117	096C	42DD
306	10942	14714	2ABE	397A	5471	7357	155F	1CBD	15453	15837	3C5D	3DDD
307	377	19550	0179	4C5E	20844	9775	516C	262F	13810	22647	35F2	5877
308	14303	8866	37DF	22A2	19007	4433	4A3F	1151	12956	10700	329C	29CC
309	24427	15297	5F6B	3BC1	32357	21468	7E65	53DC	30538	30293	774A	7655
310	26629	10898	6805	2A92	26066	5449	65D2	1549	10814	5579	2A3E	15CB
311	20011	31315	4E2B	7A53	30405	29461	76C5	7315	18939	11057	49FB	2B31
312	16086	19475	3ED6	4C13	8043	26677	1F6B	6835	19767	30238	4D37	761E
313	24374	1278	5F36	04FE	12187	639	2F9B	027F	20547	14000	5043	36B0
314	9969	11431	26F1	2CA7	17064	22639	42A8	586F	29720	22860	7418	594C
315	29364	31392	72B4	7AA0	14682	15696	395A	3D50	31831	27172	7C57	6A24
316	25560	4381	63D8	111D	12780	18098	31EC	46B2	26287	307	66AF	0133
317	28281	14898	6E79	3A32	26348	7449	66EC	1D19	11310	20380	2C2E	4F9C
318	7327	23959	1C9F	5D97	24479	24823	5F9F	60F7	25724	26427	647C	673B
319	32449	16091	7EC1	3EDB	28336	20817	6EB0	5151	21423	10702	53AF	29CE
320	26334	9037	66DE	234D	13167	24474	336F	5F9A	5190	30024	1446	7548
321	14760	24162	39A8	5E62	7380	12081	1CD4	2F31	258	14018	0102	36C2
322	15128	6383	3B18	18EF	7564	16971	1D8C	424B	13978	4297	369A	10C9
323	29912	27183	74D8	6A2F	14956	31531	3A6C	7B2B	4670	13938	123E	3672
324	4244	16872	1094	41E8	2122	8436	084A	20F4	23496	25288	5BC8	62C8
325	8499	9072	2133	2370	16713	4536	4149	11B8	23986	27294	5DB2	6A9E
326	9362	12966	2492	32A6	4681	6483	1249	1953	839	31835	0347	7C5B
327	10175	28886	27BF	70D6	16911	14443	420F	386B	11296	8228	2C20	2024
328	30957	25118	78ED	621E	28070	12559	6DA6	310F	30913	12745	78C1	31C9
329	12755	20424	31D3	4FC8	18745	10212	4939	27E4	27297	6746	6AA1	1A5A
330	19350	6729	4B96	1A49	9675	17176	25CB	4318	10349	1456	286D	05B0
331	1153	20983	0481	51F7	21392	26311	5390	66C7	32504	27743	7EF8	6C5F
332	29304	12372	7278	3054	14652	6186	393C	182A	18405	27443	47E5	6B33
333	6041	13948	1799	367C	23068	6974	5A1C	1B3E	3526	31045	0DC6	7945
334	21668	27547	54A4	6B9B	10834	31729	2A52	7BF1	19161	12225	4AD9	2FC1
335	28048	8152	6D90	1FD8	14024	4076	36C8	0FEC	23831	21482	5D17	53EA
336	10096	17354	2770	43CA	5048	8677	13B8	21E5	21380	14678	5384	3956
337	23388	17835	5B5C	45AB	11694	27881	2DAE	6CE9	4282	30656	10BA	77C0
338	15542	14378	3CB6	382A	7771	7189	1E5B	1C15	32382	13721	7E7E	3599
339	24013	7453	5DCD	1D1D	32566	16562	7F36	40B2	806	21831	0326	5547
340	2684	26317	0A7C	66CD	1342	32090	053E	7D5A	6238	30208	185E	7600
341	19018	5955	4A4A	1743	9509	17821	2525	459D	10488	9995	28F8	270B
342	25501	10346	639D	286A	24606	5173	601E	1435	19507	3248	4C33	0CB0
343	4489	13200	1189	3390	22804	6600	5914	19C8	27288	12030	6A98	2EFE
344	31011	30402	7923	76C2	27969	15201	6D41	3B61	2390	5688	0956	1638
345	29448	7311	7308	1C8F	14724	16507	3984	407B	19094	2082	4A96	0822
346	25461	3082	6375	0C0A	24682	1541	606A	0605	13860	23143	3624	5A67
347	11846	21398	2E46	5396	5923	10699	1723	29CB	9225	25906	2409	6532
348	30331	31104	767B	7980	27373	15552	6AED	3CC0	2505	15902	09C9	3E1E
349	10588	24272	295C	5ED0	5294	12136	14AE	2F68	27806	21084	6C9E	525C
350	32154	27123	7D9A	69F3	16077	31429	3ECD	7AC5	2408	25723	0968	647B

... continued on next page

E

Table E-1: PnMaskI and PnMaskQ Values for PilotPn

Pilot PN	14-Chip Delay				13-Chip Delay				0-Chip Delay			
	I (Dec.)	Q	I (Hex.)	Q	I (Dec.)	Q	I (Hex.)	Q	I (Dec.)	Q	I (Hex.)	Q
351	29572	5578	7384	15CA	14786	2789	39C2	0AE5	13347	13427	3423	3473
352	13173	25731	3375	6483	18538	31869	486A	7C7D	7885	31084	1ECD	796C
353	10735	10662	29EF	29A6	17703	5331	4527	14D3	6669	24023	1A0D	5DD7
354	224	11084	00E0	2B4C	112	5542	0070	15A6	8187	23931	1FFB	5D7B
355	12083	31098	2F33	797A	17993	15549	4649	3CBD	18145	15836	46E1	3DDC
356	22822	16408	5926	4018	11411	8204	2C93	20C0	14109	6085	371D	17C5
357	2934	6362	0B76	18DA	1467	3181	05BB	006D	14231	30324	3797	7674
358	27692	2719	6C2C	0A9F	13846	19315	3616	4B73	27606	27561	6BD6	6BA9
359	10205	14732	27DD	398C	16958	7366	423E	1CC6	783	13821	030F	35FD
360	7011	22744	1B63	58D8	23649	11372	5C61	2C6C	6301	269	189D	010D
361	22098	1476	5652	05C4	11049	738	2B29	02E2	5067	28663	13CB	6FF7
362	2640	8445	0A50	20FD	1320	24130	0528	5E42	15383	29619	3C17	73B3
363	4408	21118	1138	527E	2204	10559	089C	293F	1392	2043	0570	07FB
364	102	22198	0066	56B6	51	11099	0033	2B5B	7641	6962	1DD9	1B32
365	27632	22030	6BF0	560E	13816	11015	35F8	2B07	25700	29119	6464	71BF
366	19646	10363	4CBE	287B	9823	23041	265F	5A01	25259	22947	62AB	59A3
367	26967	25802	6957	64CA	25979	12901	657B	3265	19813	9612	4D65	258C
368	32008	2496	7D08	09C0	16004	1248	3E84	04E0	20933	18698	51C5	490A
369	7873	31288	1EC1	7A38	24240	15644	5EB0	3D1C	638	16782	027E	418E
370	655	24248	028F	5EB8	20631	12124	5097	2F5C	16318	29735	3FBE	7427
371	25274	14327	62BA	37F7	12637	21959	315D	55C7	6878	2136	1ADE	0858
372	16210	23154	3F52	5A72	8105	11577	1FA9	2D39	1328	8086	0530	1F96
373	11631	13394	2D6F	3452	18279	6697	4767	1A29	14744	10553	3998	2939
374	8535	1806	2157	070E	16763	903	417B	0387	22800	11900	5910	2E7C
375	19293	17179	4B5D	431B	29822	28593	747E	6FB1	25919	19996	653F	4E1C
376	12110	10856	2F4E	2A68	6055	5428	17A7	1534	4795	5641	12BB	1609
377	21538	25755	5422	649B	10769	31857	2A11	7C71	18683	28328	48FB	6EA8
378	10579	15674	2953	3D3A	17785	7837	4579	1E9D	32658	25617	7F92	6411
379	13032	7083	32E8	1BAB	6516	17385	1974	43E9	1586	26986	0632	696A
380	14717	29096	397D	71A8	19822	14548	4D6E	38D4	27208	5597	6A48	15DD
381	11666	3038	2D92	0BDE	5833	1519	16C9	05EF	17517	14078	446D	36FE
382	25809	16277	64D1	3F95	25528	20982	63B8	51F6	599	13247	0257	33BF
383	5008	25525	1390	63B5	2504	32742	09C8	7FE6	16253	499	3F7D	01F3
384	32418	20465	7EA2	4FF1	16209	27076	3F51	69C4	8685	30469	21ED	7705
385	22175	28855	569F	70B7	31391	30311	7A9F	7667	29972	17544	7514	4488
386	11742	32732	2DDE	7FDC	5871	16366	16EF	3FEE	22128	28510	5670	6F5E
387	22546	20373	5812	4F95	11273	27126	2C09	69F6	19871	23196	4D9F	5A9C
388	21413	9469	53A5	24FD	30722	23618	7802	5C42	19405	13384	4BCD	3448
389	133	26155	0085	662B	20882	32041	5192	7D29	17972	4239	4634	108F
390	4915	6957	1333	1B2D	22601	17322	5849	43AA	8599	20725	2197	50F5
391	8736	12214	2220	2FB6	4368	6107	1110	17DB	10142	6466	279E	1942
392	1397	21479	0575	53E7	21354	26575	536A	67CF	26834	28465	68D2	6F31
393	18024	31914	4668	7CAA	9012	15957	2334	3E55	23710	19981	5C9E	4E0D
394	15532	32311	3CAC	7E37	7766	28967	1E56	7127	27280	16723	6A90	4153
395	26870	11276	68F6	2C0C	13435	5638	347B	1606	6570	4522	19AA	11AA
396	5904	20626	1710	5092	2952	10313	0B88	2849	7400	678	1CE8	02A6
397	24341	423	5F15	01A7	32346	20207	7E5A	4EEF	26374	15320	6706	3BD8
398	13041	2679	32F1	0A77	18600	19207	48A8	4B07	22218	29116	56CA	71BC
399	23478	15537	5BB6	3CB1	11739	20580	2DDB	5064	29654	5388	73D6	150C
400	1862	10818	0746	2A42	931	5409	03A3	1521	13043	22845	32F3	593D

... continued on next page

Table E-1: PnMaskI and PnMaskQ Values for PilotPn

Pilot PN	14-Chip Delay				13-Chip Delay				0-Chip Delay			
	I (Dec.)	Q	I (Hex.)	Q	I (Dec.)	Q	I (Hex.)	Q	I (Dec.)	Q	I (Hex.)	Q
401	5850	23074	16DA	5A22	2925	11537	0B6D	2D11	24457	28430	5F89	6F0E
402	5552	20250	15B0	4F1A	2776	10125	0AD8	278D	17161	8660	4309	21D4
403	12589	14629	312D	3925	18758	21166	4946	52AE	21314	2659	5342	0A63
404	23008	29175	59E0	71F7	11504	30407	2CF0	76C7	28728	8803	7038	2263
405	27636	13943	6BF4	3677	13818	21767	35FA	5507	22162	19690	5692	4CEA
406	17600	11072	44C0	2B40	8800	5536	2260	15A0	26259	22169	6693	5699
407	17000	29492	4268	7334	8500	14746	2134	399A	22180	8511	56A4	213F
408	21913	5719	5599	1657	31516	17687	7B1C	4517	2266	17393	08DA	43F1
409	30320	7347	7670	1CB3	15160	16485	3B38	4065	10291	11336	2833	2C48
410	28240	12156	6E50	2F7C	14120	6078	3728	17BE	26620	13576	67FC	3508
411	7260	25623	1C5C	6417	3630	31799	0E2E	7C37	19650	22820	4CC2	5924
412	17906	27725	45F2	6C4D	8953	30746	22F9	781A	14236	13344	379C	3420
413	5882	28870	16FA	70C6	2941	14435	0B7D	3863	11482	20107	2CDA	4E8B
414	22080	31478	5640	7AF6	11040	15739	2B20	3D7B	25289	8013	62C9	1F4D
415	12183	28530	2F97	6F72	17947	14265	461B	37B9	12011	18835	2EEB	4993
416	23082	24834	5A2A	6102	11541	12417	2D15	3081	13892	16793	3644	4199
417	17435	9075	441B	2373	29661	24453	73DD	5F85	17336	9818	43B8	265A
418	18527	32265	485F	7E09	30207	28984	75FF	7138	10759	4673	2A07	1241
419	31902	3175	7C9E	0C67	15951	18447	3E4F	480F	26816	13609	68C0	3529
420	18783	17434	495F	441A	30079	8717	757F	220D	31065	10054	7959	2746
421	20027	12178	4E3B	2F92	30413	6089	76CD	17C9	8578	10988	2182	2AEC
422	7982	25613	1F2E	640D	3991	31802	0F97	7C3A	24023	14744	5DD7	3998
423	20587	31692	506B	7BCC	31205	15846	79E5	3DE6	16199	17930	3F47	460A
424	10004	25384	2714	6328	5002	12692	138A	3194	22310	25452	5726	636C
425	13459	18908	3493	49DC	19353	9454	4B99	24EE	30402	11334	76C2	2C46
426	13383	25816	3447	64D8	19443	12908	4BF3	326C	16613	15451	40E5	3C5B
427	28930	4661	7102	1235	14465	18214	3881	4726	13084	11362	331C	2C62
428	4860	31115	12FC	798B	2430	29433	097E	72F9	3437	2993	0D6D	0BB1
429	13108	7691	3334	1E0B	6554	16697	199A	4139	1703	11012	06A7	2B04
430	24161	1311	5E61	051F	32480	19635	7EE0	4CB3	22659	5806	5883	16AE
431	20067	16471	4E63	4057	30433	28183	76E1	6E17	26896	20180	6910	4ED4
432	2667	15771	0A6B	3D9B	21733	20721	54E5	50F1	1735	8932	06C7	22E4
433	13372	16112	343C	3EF0	6686	8056	1A1E	1F78	16178	23878	3F32	5D46
434	28743	21062	7047	5246	27123	10531	69F3	2923	19166	20760	4ADE	5118
435	24489	29690	5FA9	73FA	32260	14845	7E04	39FD	665	32764	0299	7FFC
436	249	10141	00F9	279D	20908	24050	51AC	5DF2	20227	32325	4F03	7E45
437	19960	19014	4DF8	4A46	9980	9507	26FC	2523	24447	25993	5F7F	6589
438	29682	22141	73F2	567D	14841	25858	39F9	6502	16771	3268	4183	0CC4
439	31101	11852	797D	2E4C	28014	5926	6D6E	1726	27209	25180	6A49	625C
440	27148	26404	6A0C	6724	13574	13202	3506	3392	6050	12149	17A2	2F75
441	26706	30663	6852	77C7	13353	30175	3429	75DF	29088	10193	71A0	27D1
442	5148	32524	141C	7F0C	2574	16262	0A0E	3F86	7601	9128	1DB1	23A8
443	4216	28644	1078	6FE4	2108	14322	083C	37F2	4905	7843	1329	1EA3
444	5762	10228	1682	27F4	2881	5114	0B41	13FA	5915	25474	171B	6382
445	245	23536	00F5	5BF0	20906	11768	51AA	2DF8	6169	11356	1819	2C5C
446	21882	18045	557A	467D	10941	27906	2ABD	6D02	21303	11226	5337	2BDA
447	3763	25441	0EB3	6361	22153	32652	5689	7F8C	28096	16268	6DC0	3F8C
448	206	27066	00CE	69BA	103	13533	0067	34DD	8905	14491	22C9	389B
449	28798	13740	707E	35AC	14399	6870	383F	1AD6	26997	8366	6975	20AE
450	32402	13815	7E92	35F7	16201	21703	3F49	54C7	15047	26009	3AC7	6599

... continued on next page



Table E-1: PnMaskI and PnMaskQ Values for PilotPn

Pilot PN	14-Chip Delay		13-Chip Delay				0-Chip Delay					
	I (Dec.)	Q (Hex.)	I (Dec.)	Q (Hex.)	I (Dec.)	Q (Hex.)	I (Dec.)	Q (Hex.)	I (Dec.)	Q (Hex.)		
451	13463	3684	3497	0E64	19355	1842	4B9B	0732	17460	5164	4434	142C
452	15417	23715	3C39	5CA3	20428	24685	4FCC	606D	17629	17126	44DD	42E6
453	23101	15314	5A3D	3BD2	31950	7657	7CCE	1DE9	10461	21566	28DD	543E
454	14957	32469	3A6D	7ED5	19686	29014	4CE6	7156	21618	21845	5472	5555
455	23429	9816	5B85	2658	31762	4908	7C12	132C	11498	28149	2CEA	6DF5
456	12990	4444	32BE	115C	6495	2222	195F	08AE	193	9400	00C1	24B8
457	12421	5664	3085	1620	18834	2832	4992	0B10	16140	19459	3F0C	4C03
458	28875	7358	70CB	1CBE	27061	3679	69B5	0E5F	13419	7190	346B	1C16
459	4009	27264	0FA9	6A80	22020	13632	5604	3540	10864	3101	2A70	0C1D
460	1872	28128	0750	6DE0	936	14064	03A8	36F0	28935	491	7107	01EB
461	15203	30168	3B63	75D8	19553	15084	4C61	3AEC	18765	25497	494D	6399
462	30109	29971	759D	7513	27422	29877	6B1E	74B5	27644	29807	6BFC	746F
463	24001	3409	5DC1	0D51	32560	18580	7F30	4894	21564	26508	543C	678C
464	4862	16910	12FE	420E	2431	8455	097F	2107	5142	4442	1416	115A
465	14091	20739	370B	5103	19029	26301	4A55	66BD	1211	4871	04BB	1307
466	6702	10191	1A2E	27CF	3351	24027	0D17	5DDB	1203	31141	04B3	79A5
467	3067	12819	0BFB	3213	21549	22325	542D	5735	5199	9864	144F	2688
468	28643	19295	6FE3	4B5F	26145	27539	6621	6B93	16945	12589	4231	312D
469	21379	10072	5383	2758	30737	5036	7811	13AC	4883	5417	1313	1529
470	20276	15191	4F34	3B57	10138	21399	279A	5397	25040	8549	61D0	2165
471	25337	27748	62F9	6C64	24748	13874	60AC	3632	7119	14288	1BCF	37D0
472	19683	720	4CE3	02D0	30625	360	77A1	0168	17826	8503	45A2	2137
473	10147	29799	27A3	7467	16897	29711	4201	740F	4931	20357	1343	4F85
474	16791	27640	4197	6BF8	28955	13820	711B	35FC	25705	15381	6469	3C15
475	17359	263	43CF	0107	28727	20159	7037	4EBF	10726	18065	29E6	4691
476	13248	24734	33C0	609E	6624	12367	19E0	304F	17363	24678	43D3	6066
477	22740	16615	58D4	40E7	11370	28239	2C6A	6E4F	2746	23858	0ABA	5D32
478	13095	20378	3327	4F9A	18499	10189	4843	27CD	10952	7610	2AC8	1DBA
479	10345	25116	2869	621C	17892	12558	45E4	310E	19313	18097	4B71	46B1
480	30342	19669	7686	4CD5	15171	26710	3B43	6856	29756	20918	743C	51B6
481	27866	14656	6CDA	3940	13933	7328	366D	1CA0	14297	7238	37D9	1C46
482	9559	27151	2557	6A0F	17275	31547	437B	7B3B	21290	30549	532A	7755
483	8808	28728	2268	7038	4404	14364	1134	381C	1909	16320	0775	3FC0
484	12744	25092	31C8	6204	6372	12546	18E4	3102	8994	20853	2322	5175
485	11618	22601	2D62	5849	5809	25112	16B1	6218	13295	26736	33EF	6870
486	27162	2471	6A1A	09A7	13581	19183	350D	4AEF	21590	10327	5456	2857
487	17899	25309	45EB	62DD	29477	32594	7325	7F52	26468	24404	6764	5F54
488	29745	15358	7431	3BFE	27592	7679	6BC8	1DFF	13636	7931	3544	1EFB
489	31892	17739	7C94	454B	15946	27801	3E4A	6C99	5207	5310	1457	14BE
490	23964	12643	5D9C	3163	11982	22157	2ECE	568D	29493	554	7335	022A
491	23562	32730	5C0A	7FDA	11781	16365	2E05	3FED	18992	27311	4A30	6AAF
492	2964	19122	0B94	4AB2	1482	9561	05CA	2559	12567	6865	3117	1AD1
493	18208	16870	4720	41E6	9104	8435	2390	20F3	12075	7762	2F2B	1E52
494	15028	10787	3AB4	2A23	7514	23341	1D5A	5B2D	26658	15761	6822	3D91
495	21901	18400	558D	47E0	31510	9200	7B16	23F0	21077	12697	5255	3199
496	24566	20295	5FF6	4F47	12283	27039	2FFB	699F	15595	24850	3CEB	6112
497	18994	1937	4A32	0791	9497	19956	2519	4DF4	4921	15259	1339	3B9B
498	13608	17963	3528	462B	6804	27945	1A94	6D29	14051	24243	36E3	5EB3
499	27492	7438	6B64	1D0E	13746	3719	35B2	0E87	5956	30508	1744	772C
500	11706	12938	2DBA	328A	5853	6469	16DD	1945	21202	13982	52D2	369E

... continued on next page

Table E-1: PnMaskI and PnMaskQ Values for PilotPn

Pilot PN	14-Chip Delay				13-Chip Delay				0-Chip Delay			
	I (Dec.)	Q	I (Hex.)	Q	I (Dec.)	Q	I (Hex.)	Q	I (Dec.)	Q	I (Hex.)	Q
501	14301	19272	37DD	4B48	19006	9636	4A3E	25A4	11239	25039	2BE7	61CF
502	23380	29989	5B54	7525	11690	29870	2DAA	74AE	30038	24086	7556	5E16
503	11338	8526	2C4A	214E	5669	4263	1625	10A7	30222	21581	760E	544D
504	2995	18139	0BB3	46DB	21513	27985	5409	6D51	13476	21346	34A4	5362
505	23390	3247	5B5E	0CAF	11695	18539	2DAF	486B	2497	28187	09C1	6E1B
506	14473	28919	3889	70F7	19860	30279	4D94	7647	31842	23231	7C62	5ABF
507	6530	7292	1982	1C7C	3265	3646	0CC1	0E3E	24342	18743	5F16	4937
508	20452	20740	4FE4	5104	10226	10370	27F2	2882	25857	11594	6501	2D4A
509	12226	27994	2FC2	6D5A	6113	13997	17E1	36AD	27662	7198	6C0E	1C1E
510	1058	2224	0422	08B0	529	1112	0211	0458	24594	105	6012	0069
511	12026	6827	2EFA	1AAB	6013	17257	177D	4369	16790	4534	4196	11B6

E

Appendix F

Test Equipment Preparation

■
F
■

Test Equipment Preparation

Purpose

This appendix provides information on pre-testing set-up for the following test equipment items (not required for the Cybertest test set):

- Agilent E4406A transmitter test set
- Agilent E4432B signal generator
- Advantest R3267 spectrum analyzer
- Advantest R3562 signal generator
- Agilent 8935 analyzer (formerly HP 8935)
- HP 8921 with PCS interface analyzer
- Advantest R3465 analyzer
- HP 437 power meter
- Gigatronics 8541C power meter
- GPIB adapter

Pre-testing set-up information covered includes verification and setting GPIB addresses, inter-unit cabling, connectivity testing, pre-test control settings, and equipment calibration for items which are not calibrated with the **Calibrate Test Equipment** function of the LMF.

Setting GPIB Addresses

Procedures for Verifying and Setting CDMA Support Equipment GPIB Addresses

The following procedures cover verification and changing GPIB addresses for the various items of CDMA test equipment supported by the LMF.

Agilent E4406A Transmitter Tester GPIB Address

Figure F-1: Setting Agilent E4406A GPIB Address

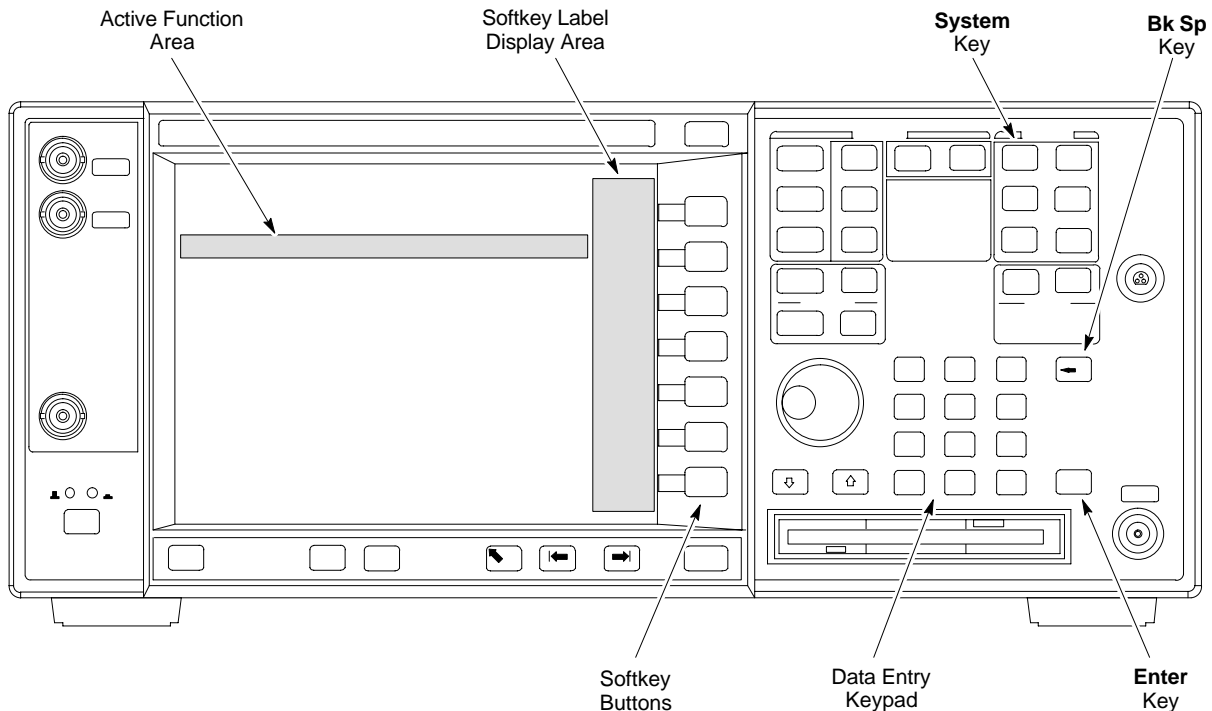

Refer to Figure F-1 and follow the procedure in Table F-1 to verify and, if necessary, change the Agilent E4406A GPIB address.

Table F-1: Verify and Change Agilent E4406A GPIB Address

Step	Action
1	In the SYSTEM section of the instrument front panel, press the System key. <ul style="list-style-type: none"> - The softkey labels displayed on the right side of the instrument screen will change.
2	Press the Config I/O softkey button to the right of the instrument screen. <ul style="list-style-type: none"> - The softkey labels will change. - The current instrument GPIB address will be displayed below the GPIB Address softkey label.
3	If the current GPIB address is not set to 18 , perform the following to change it:
3a	<ul style="list-style-type: none"> - Press the GPIB Address softkey button. <ul style="list-style-type: none"> -- In the on-screen Active Function Area, GPIB Address will be displayed followed by the current GPIB address.

... continued on next page

Table F-1: Verify and Change Agilent E4406A GPIB Address

Step	Action
3b	<ul style="list-style-type: none"> - On the front panel Data Entry keypad, enter the communications system analyzer GPIB address of 18. -- The GPIB Address label will change to Enter. -- Characters typed on the keypad will replace the current GPIB address in the Active Function Area. <p>NOTE To correct an entry, press the Bk Sp key at the upper right of the keypad to delete one character at a time.</p>
3c	<ul style="list-style-type: none"> - Press the Enter softkey button or the keypad Enter key to set the new GPIB address. -- The Config I/O softkey labels will reappear. -- The new GPIB address will be displayed under the GPIB Address softkey label.

Agilent E4432B Signal Generator GPIB Address

Figure F-2: Setting Agilent E4432B GPIB Address

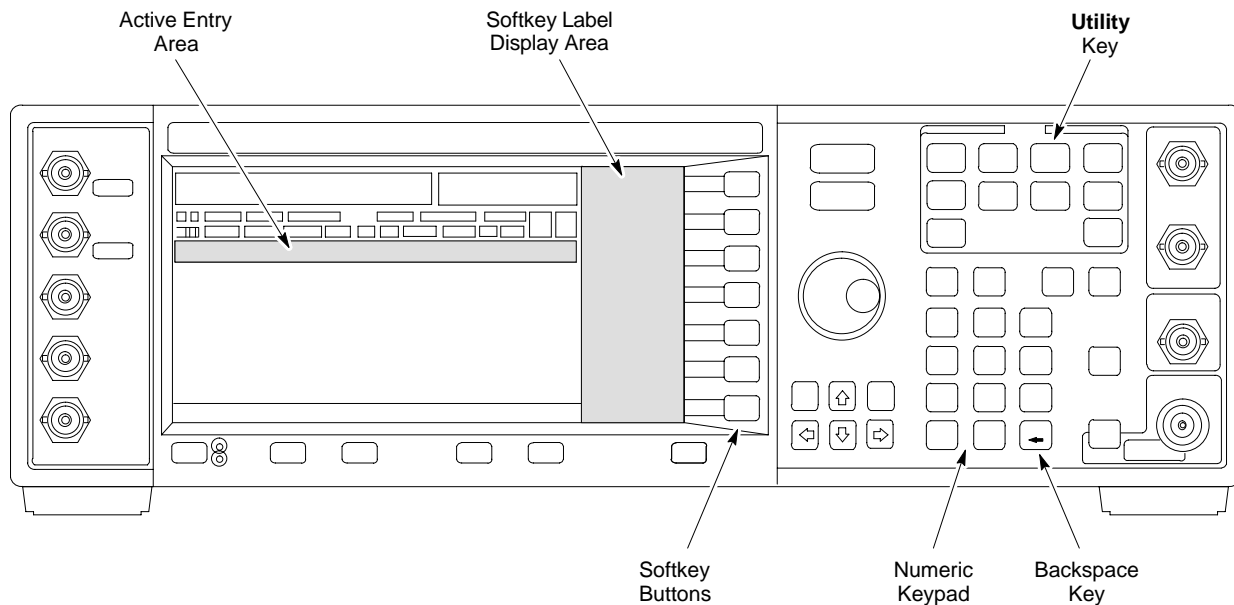

Refer to Figure F-2 and follow the procedure in Table F-2 to verify and, if necessary, change the Agilent E4432B GPIB address.

Table F-2: Verify and Change Agilent E4432B GPIB Address

Step	Action
1	In the MENUS section of the instrument front panel, press the Utility key. <ul style="list-style-type: none"> - The softkey labels displayed on the right side of the instrument screen will change.
2	Press the GPIB/RS232 softkey button to the right of the instrument screen. <ul style="list-style-type: none"> - The softkey labels will change. - The current instrument GPIB address will be displayed below the GPIB Address softkey label.

... continued on next page

Table F-2: Verify and Change Agilent E4432B GPIB Address

Step	Action
3	If the current GPIB address is not set to 1 , perform the following to change it:
3a	<ul style="list-style-type: none"> - Press the GPIB Address softkey button. -- The GPIB Address label and current GPIB address will change to boldface. -- In the on-screen Active Entry Area, Address: will be displayed followed by the current GPIB address.
3b	<ul style="list-style-type: none"> - On the front panel Numeric keypad, enter the signal generator GPIB address of 1. -- The GPIB Address label will change to Enter. -- Characters typed on the keypad will replace the current GPIB address in the Active Entry display.
<p>NOTE To correct an entry, press the backspace key at the lower right of the keypad to delete one character at a time.</p>	
3c	<ul style="list-style-type: none"> - Press the Enter softkey button to set the new GPIB address. -- The new GPIB address will be displayed under the GPIB Address softkey label.

Advantest R3267 Spectrum Analyzer GPIB Address

Figure F-3: Setting Advantest R3267 GPIB Address

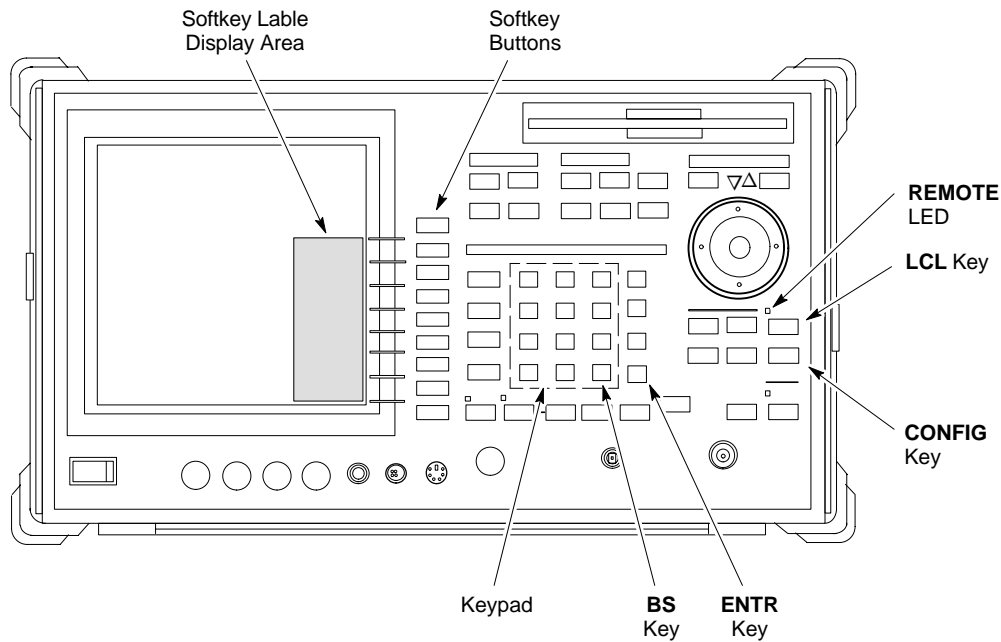

Refer to Figure F-3 and perform the procedure in Table F-3 to verify and, if necessary, change the Advantest R3267 spectrum analyzer GPIB address.



Table F-3: Verify and Change Advantest R3267 GPIB Address

Step	Action
1	If the REMOTE LED is lighted, press the LCL key. - The LED extinguishes.
2	Press the CONFIG key. - The CONFIG softkey labels will appear in the softkey label display area of the instrument display. - The current GPIB address will be displayed below the GPIB Address softkey label.
3	If the current GPIB address is not set to 18 , perform the following to change it: 3a - Press the GPIB Address softkey. -- A GPIB Address entry window will open in the instrument display showing the current GPIB address. 3b - Enter 18 on the keypad in the ENTRY section of the instrument front panel. -- Characters typed on the keypad will replace the address displayed in the GPIB Address entry window. NOTE To correct an entry, press the BS (backspace) key at the lower right of the keypad to delete one character at a time. 3c - Press the ENTR key to the lower right of the keypad to set the new GPIB address. -- The GPIB Address entry window closes. -- The new address is displayed in the bottom portion of the GPIB Address softkey label.

F

Advantest R3562 Signal Generator GPIB Address

Set the **GP-IB ADDRESS** switch on the rear of the Advantest R3562 signal generator to address **1** as shown in Figure F-4.

Figure F-4: Advantest R3562 GPIB Address Switch Setting

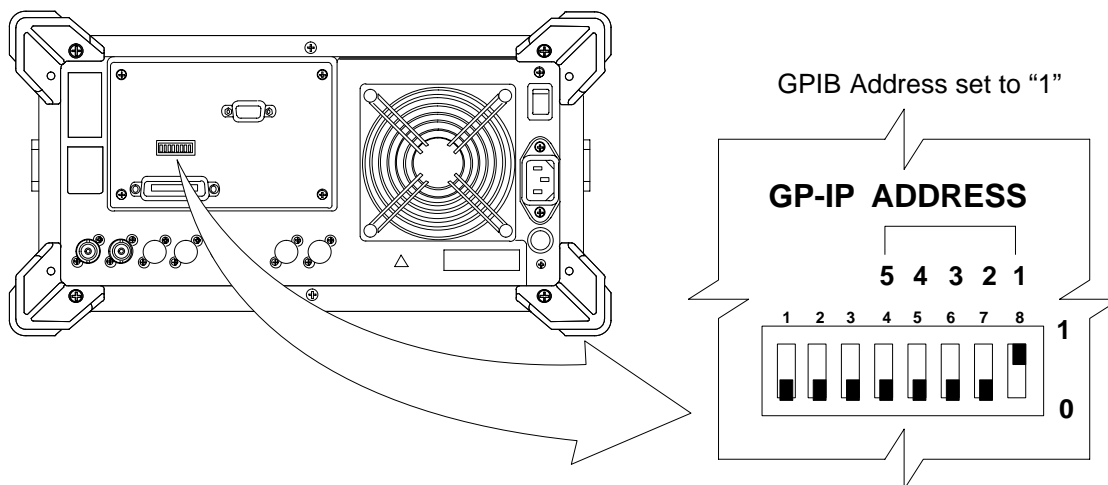

Agilent 8935 Series E6380 (formerly HP 8935) Test Set GPIB Address

Figure F-5: Agilent 8935 Test Set

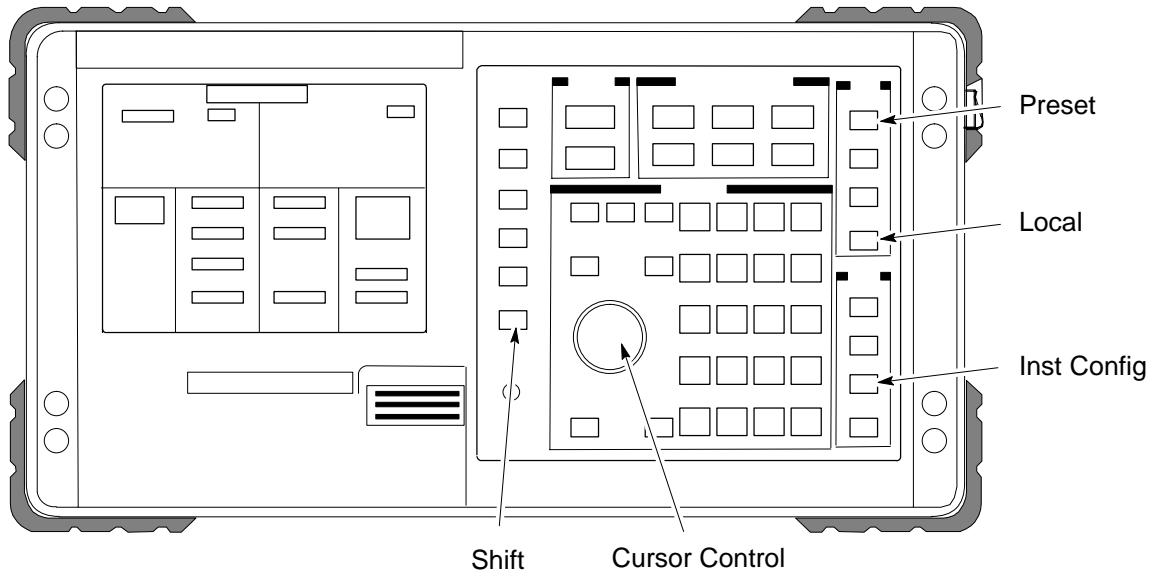

FW00885

Refer to Figure F-5 and follow the procedure in Table F-4 to verify and, if necessary, change the Agilent 8935 GPIB address.

NOTE This procedure assumes that the test equipment is set up and ready for testing.

Table F-4: Verify and/or Change Agilent 8935 (formerly HP 8935) GPIB Address

Step	Action
1	<p>NOTE The HP I/O configuration MUST be set to Talk & Listen, or <i>no</i> device on the GPIB will be accessible. (Consult test equipment OEM documentation for additional information as required.)</p> <p>To verify that the GPIB addresses are set correctly, press Shift and LOCAL on the Agilent 8935.</p> <ul style="list-style-type: none"> - The current HP-IB address is displayed at the top of the screen. <p>NOTE HP-IB is the same as GPIB.</p>
2	If the current GPIB address is not set to 18 , perform the following to change it:
2a	- Press Shift and Inst Config .
2b	- Turn the Cursor Control knob to move the cursor to the HP-IB Adrs field.
2c	- Press the Cursor Control knob to select the field.
2d	- Turn the Cursor Control knob as required to change the address to 18 .
2e	- Press the Cursor Control knob to set the address.
3	Press Preset to return to normal operation.

■
F
■

Setting HP 8921A and HP 83236A/B GPIB Address

Figure F-6: HP 8921A and HP 83236A/B

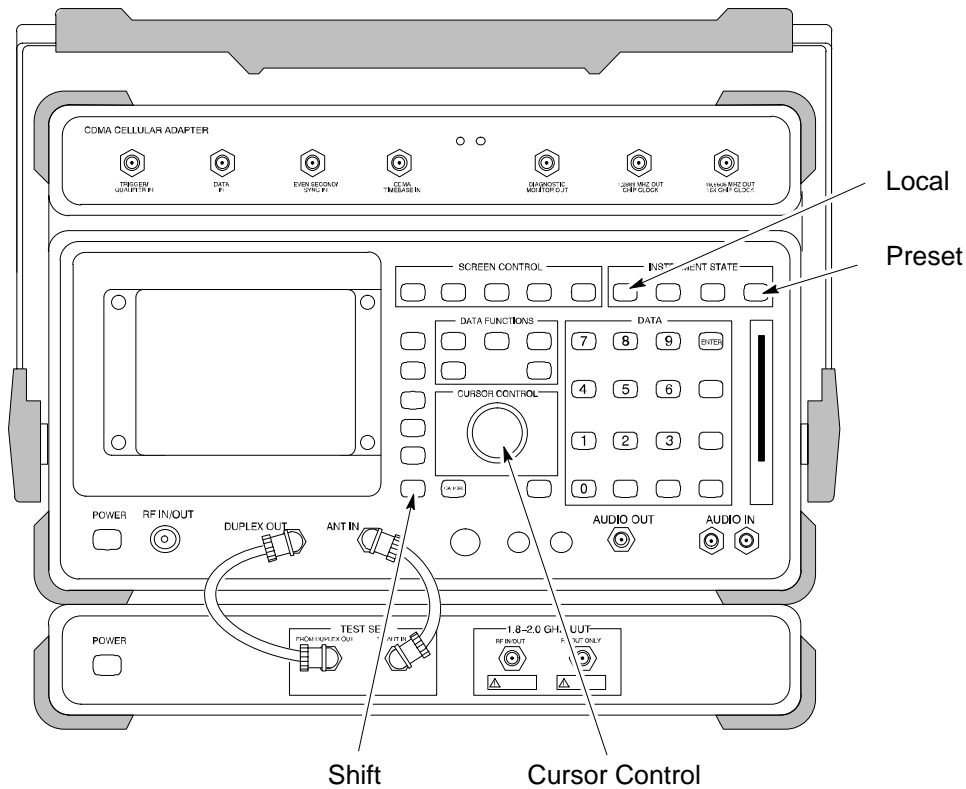

F

Refer to Figure F-6 and follow the procedure in Table F-5 to verify and, if necessary, change the HP 8921A HP 83236A GPIB addresses.

NOTE This procedure assumes that the test equipment is set up and ready for testing.

Table F-5: Verify and/or Change HP 8921A and HP 83236A GPIB Addresses

Step	Action
1	To verify that the GPIB addresses are set correctly, press Shift and LOCAL on the HP 8921A. <ul style="list-style-type: none"> - The current HP-IB address is displayed at the top of the screen. <p>NOTE HP-IB is the same as GPIB.</p>
2	If the current HP-IB address is not set to 18 , perform the following to change it:
2a	- Turn the Cursor Control knob to move the cursor to More and press the knob to select the field.
2b	- Turn the Cursor Control knob to move the cursor to I/O Config and press the knob to select the field.
2c	- Turn the Cursor Control knob to move the cursor to Adrs and press the knob to select the field.
2d	- Turn the Cursor Control knob to change the HP-IB address to 18 and press the knob to set the address.

Table F-5: Verify and/or Change HP 8921A and HP 83236A GPIB Addresses

Step	Action
2e	- Press Shift and Preset to return to normal operation.
3	To set the HP 83236A (or B) PCS Interface GPIB address= 19 , set the DIP switches as follows: - A1=1, A2=1, A3=0, A4=0, A5=1, HP-IB/Ser = 1

Advantest R3465 GPIB Address

Figure F-7: R3465 Communications Test Set

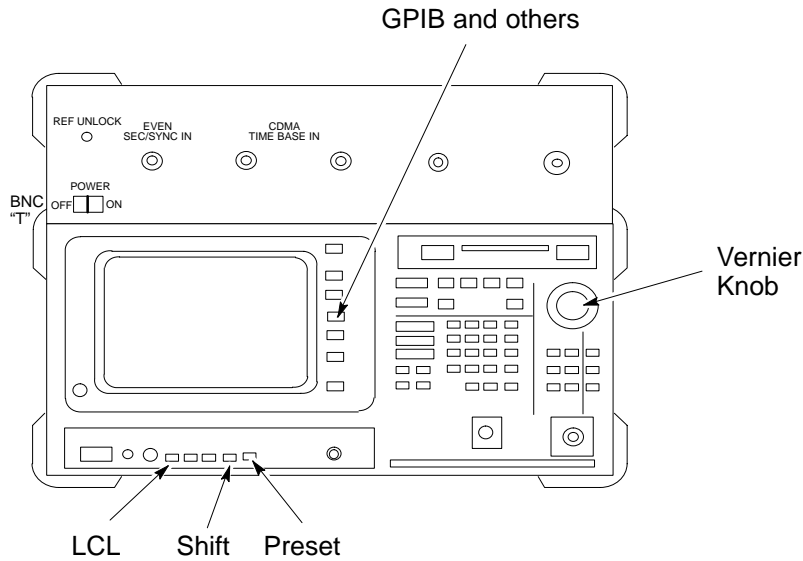

REF FW00337

Refer to Figure F-7 and follow the procedure in Table F-6 to verify and, if necessary, change the GPIB address for the Advantest R3465.

NOTE This procedure assumes that the test equipment is set up and ready for testing.

Table F-6: Verify and/or Change Advantest R3465 GPIB Address

Step	Action
1	To verify that the GPIB address is set correctly, perform the following:
1a	- Press SHIFT then PRESET .
1b	- Press LCL .
1c	- Press the GPIB and Others CRT menu key to view the current address.
2	If the current GPIB address is not set to 18 , perform the following to change it:
2a	- Turn the vernier knob as required to select 18 .
2b	- Press the vernier knob to set the address.
3	To return to normal operation, press Shift and Preset .



Motorola CyberTest GPIB Address

Follow the steps in Table F-7 to verify and, if necessary, change the GPIB address on the Motorola CyberTest. Changing the GPIB address requires the following items:

- Motorola CyberTest communications analyzer.
- Computer running Windows 3.1/Windows 95.
- Motorola CyberTAME software program “TAME”.
- Parallel printer port cable (shipped with CyberTest).

NOTE This procedure assumes that the test equipment is set up and ready for testing.

Table F-7: Verify and/or Change Motorola CyberTest GPIB Address

Step	Action
1	On the LMF desktop, locate the CyberTAME icon. Double click on the icon to run the CyberTAME application.
2	In the CyberTAME window taskbar, under Special , select IEEE.488.2 .
3	CyberTAME software will query the CyberTest Analyzer for its current GPIB address. It then will open the IEEE 488.2 dialog box. If the current GPIB address is not 18 , perform the following procedure to change it:
3a	- Use the up or down increment arrows or double-click in the field and type the number to set the address to 18 .
3b	- Click on the OK button. -- The new address will be written to the CyberTest through the parallel port and saved.
4	Verify that the address has been set by repeating steps 2 and 3. - The new address should now appear in the IEEE 488.2 dialog box Address field.

■
F
■

HP 437 Power Meter GPIB Address

Figure F-8: HP 437 Power Meter

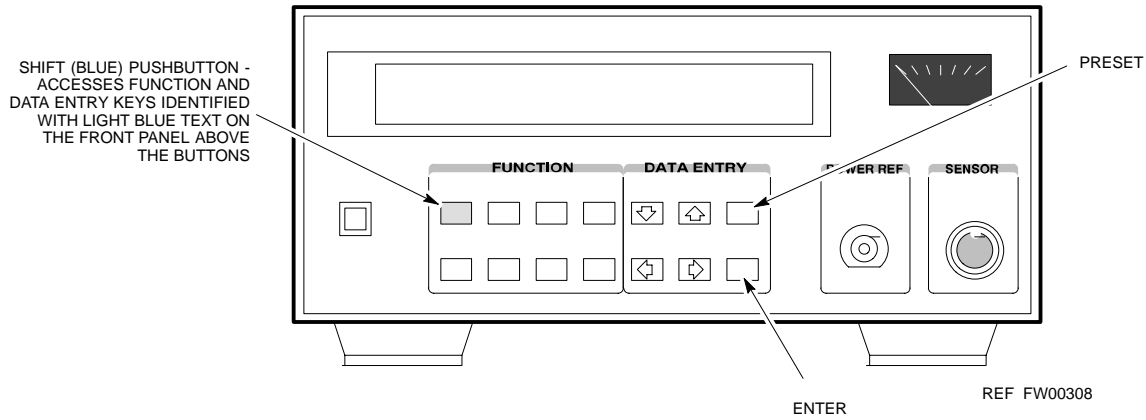

Refer to Figure F-8 and follow the steps in Table F-8 to verify and, if necessary, change the HP 437 GPIB address.

NOTE This procedure assumes that the test equipment is set up and ready for testing.

Table F-8: Verify and/or Change HP 437 Power Meter GPIB Address

Step	Action
1	Press Shift and PRESET .
2	Use the ▲ arrow key to navigate to HP-IB ADRS and press ENTER . The HP-IB address is displayed. NOTE HP-IB is the same as GPIB.
3	If the current GPIB address is not set to 13 , perform the following to change it: - Use the ▲ ▼ arrow keys to change the HP-IB ADRS to 13 . - Press ENTER to set the address.
4	Press Shift and ENTER to return to a standard configuration.

■
F
■

Gigatronics 8541C Power Meter GPIB Address

Figure F-9: Gigatronics 8541C Power Meter Detail

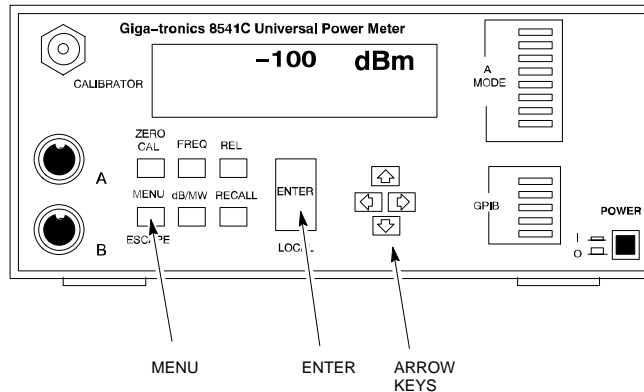

REF FW00564

Refer to Figure F-9 and follow the steps in Table F-9 to verify and, if necessary, change the Gigatronics 8541C power meter GPIB address.

NOTE This procedure assumes that the test equipment is set up and ready for testing.

Table F-9: Verify and/or Change Gigatronics 8541C Power Meter GPIB Address

Step	Action
1	! CAUTION Do not connect/disconnect the power meter sensor cable with AC power applied to the meter. Disconnection could result in destruction of the sensing element or miscalibration. Press MENU .
2	Use the ▼ arrow key to select CONFIG MENU and press ENTER .
3	Use the ▼ arrow key to select GPIB and press ENTER . The current Mode and GPIB Address are displayed.
4	If the Mode is not set to 8541C , perform the following to change it: Use the ◀▶ arrow keys as required to select MODE . Use the ▼▲ arrow keys as required to set MODE to 8541C .
5	If the GPIB address is not set to 13 , perform the following to change it: Use the ▶ arrow key to select ADDRESS . Use the ▼▲ arrow keys as required to set the GPIB address to 13 .
6	Press ENTER to return to normal operation.

F

RS-232 GPIB Interface Adapter

Be sure that the RS-232 GPIB interface adapter DIP switches are set as shown in Figure F-10.

Figure F-10: RS232 GPIB Interface Adapter

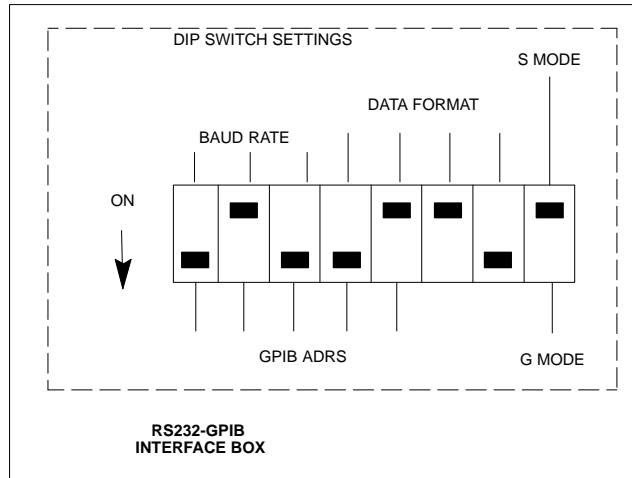

Test Equipment Inter-unit Connection, Testing, and Control

Inter-unit Connection, Testing, and Control Settings

The following illustrations, tables, and procedures provide the information necessary to prepare various items of CDMA test equipment supported by the LMF for BTS calibration and/or acceptance testing.

HP 8921A with PCS Interface Test Equipment Connections

The following diagram depicts the rear panels of the HP 8921A test equipment as configured to perform automatic tests. All test equipment is controlled by the LMF via an IEEE-488/GPIB bus. The LMF expects each piece of test equipment to have a factory-set GPIB address (refer to Table F-5 and Figure F-6). If there is a communications problem between the LMF and any piece of test equipment, verify that the GPIB addresses have been set correctly and that the GPIB cables are firmly connected to the test equipment.

Figure F-11 shows the connections when *not using* an external 10 MHz Rubidium reference.

Table F-10: HP 8921A/600 Communications Test Set Rear Panel Connections Without Rubidium Reference

From Test Set:	To Interface:		Connector Type
	8921A	83203B CDMA	
CW RF OUT	CW RF IN		SMC-female - SMC-female
114.3 MHZ IF OUT	114.3 MHZ IF IN		SMC-female - SMC-female
IQ RF IN	IQ RF OUT		SMC-female - SMC-female
DET OUT	AUX DSP IN		SMC-female - SMC-female
CONTROL I/O	CONTROL I/O		45-pin custom BUS
10 MHZ OUT	SYNTH REF IN		BNC-male - BNC-male
HPIB INTERFACE		HPIB INTERFACE	HPIB cable
	10 MHZ OUT	REF IN	BNC-male - BNC-male

F

Figure F-11: HP 8921A/600 Cable Connections for 10 MHz Signal and GPIB without Rubidium Reference

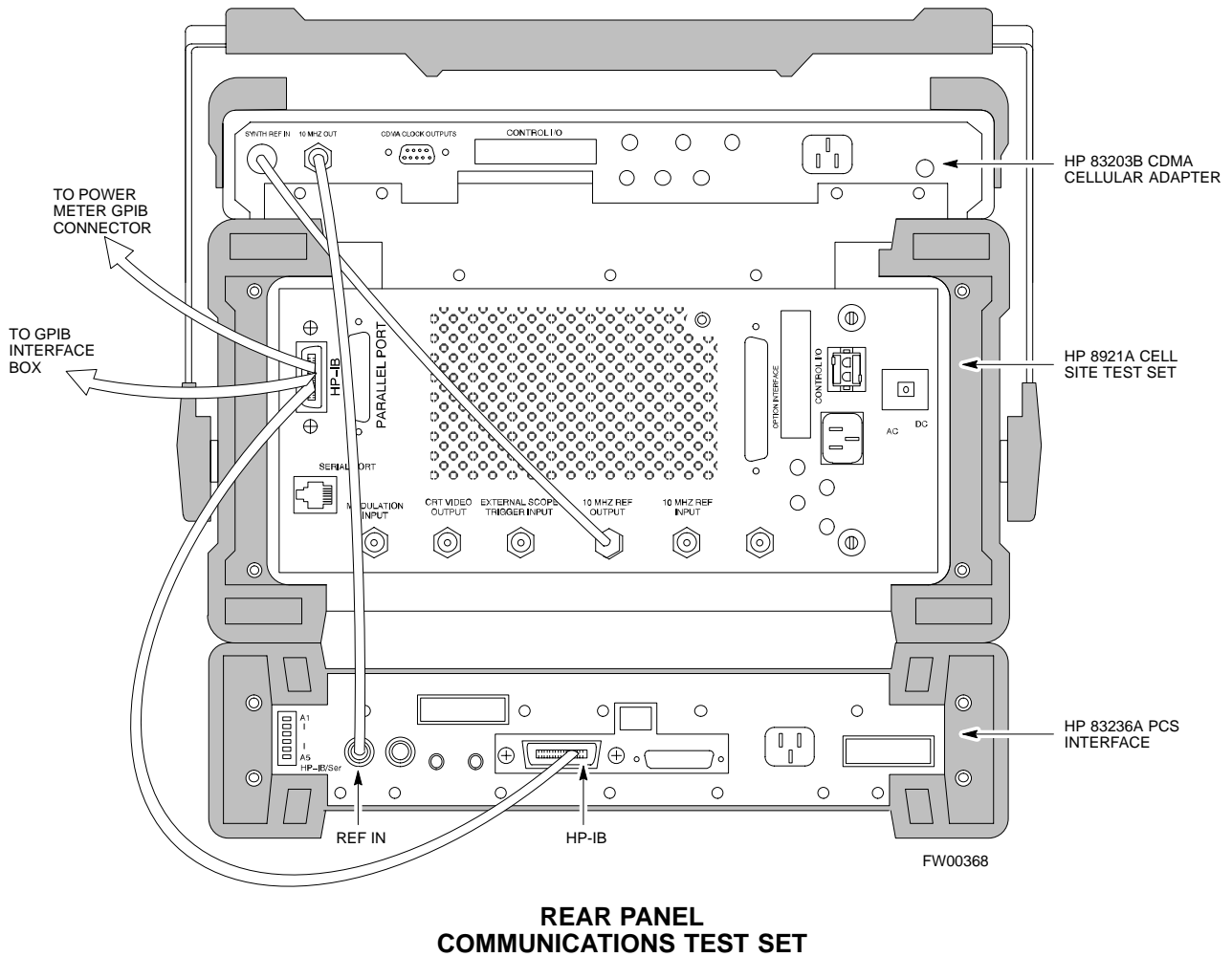

Figure F-12 shows the connections when *using* an external 10 MHz Rubidium reference.

Table F-11: HP 8921A/600 Communications Test Set Rear Panel Connections With Rubidium Reference

From Test Set:	To Interface:		Connector Type
	8921A	83203B CDMA	
CW RF OUT	CW RF IN		SMC-female - SMC-female
114.3 MHZ IF OUT	114.3 MHZ IF IN		SMC-female - SMC-female
IQ RF IN	IQ RF OUT		SMC-female - SMC-female
DET OUT	AUX DSP IN		SMC-female - SMC-female
CONTROL I/O	CONTROL I/O		45-pin custom BUS
10 MHZ OUT		REF IN	BNC-male - BNC-male
HPIB INTERFACE		HPIB INTERFACE	HPIB cable
10 MHZ INPUT	10 MHZ OUT		BNC-male - BNC-male

F

Figure F-12: HP 8921A Cable Connections for 10 MHz Signal and GPIB with Rubidium Reference

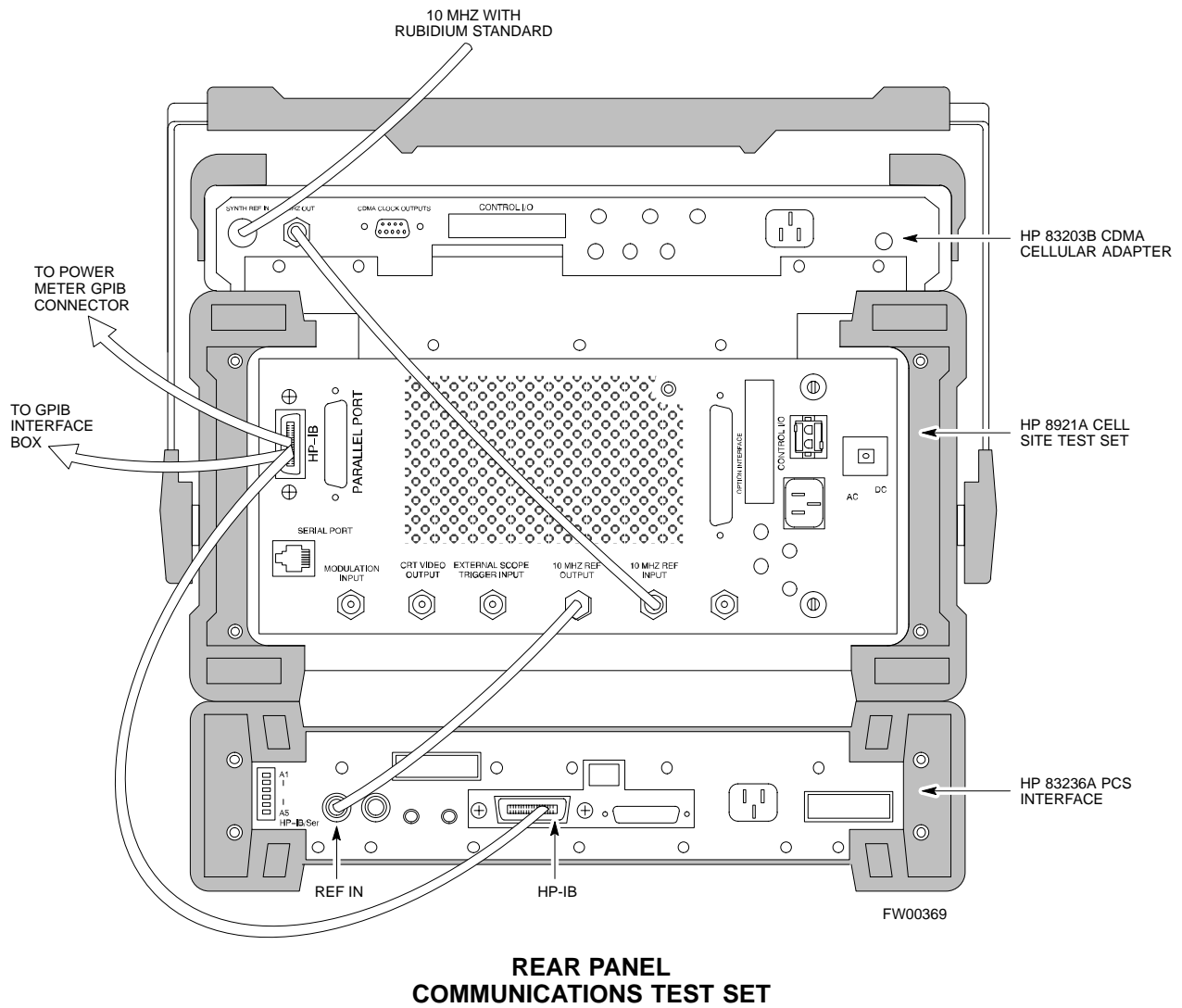

HP 8921A with PCS Interface System Connectivity Test

Follow the steps outlined in Table F-12 to verify that the connections between the PCS Interface and the HP 8921A are correct and cables are intact. The software also performs basic functionality checks of each instrument.

NOTE	Table:note. Note 10pt Helvetica Disconnect other GPIB devices, especially system controllers, from the system before running the connectivity software.
-------------	--

Table F-12: System Connectivity

Step	Action
	NOTE - Perform this procedure <i>after</i> test equipment has been allowed to warm-up and stabilize for a <i>minimum of 60 minutes</i> .
1	Insert HP 83236A Manual Control/System card into memory card slot.
2	Press the [PRESET] pushbutton.
3	Press the Screen Control [TESTS] pushbutton to display the “Tests” Main Menu screen.
4	Position the cursor at Select Procedure Location and select it by pressing the cursor control knob. In the Choices selection box, select Card .
5	Position the cursor at Select Procedure Filename and select it by pressing the cursor control knob. In the Choices selection box, select SYS_CONN .
6	Position the cursor at RUN TEST and select it. The software will provide operator prompts through completion of the connectivity setup.
7	Do the following when the test is complete, <ul style="list-style-type: none"> • position cursor on STOP TEST and select it • OR press the [K5] pushbutton.
8	To return to the main menu, press the [K5] pushbutton.
9	Press the [PRESET] pushbutton.

Pretest Setup for HP 8921A

Before the HP 8921A CDMA analyzer is used for LMF-controlled testing it must be set up correctly for automatic testing.

Table F-13: Pretest Setup for HP 8921A

Step	Action
1	Unplug the memory card if it is plugged in.
2	Press the CURSOR CONTROL knob.
3	Position the cursor at IO CONFIG (under To Screen and More) and select it.
4	Select Mode and set for Talk&Lstn .

Pretest Setup for Agilent 8935

Before the Agilent 8935 analyzer is used for LMF controlled testing it must be set up correctly for automatic testing.

Table F-14: Pretest Setup for Agilent 8935	
Step	Action
1	Unplug the memory card if it is plugged in.
2	Press the Shift button and then press the I/O Config button.
3	Press the Push to Select knob.
4	Position the cursor at IO CONFIG and select it.
5	Select Mode and set for Talk&Lstn .

Advantest R3465 Connection

The following diagram depicts the rear panels of the Advantest R3465 test equipment as configured to perform automatic tests. All test equipment is controlled by the LMF via an IEEE-488/GPIB bus. The LMF expects each piece of test equipment to have a factory-set GPIB address (refer to Table F-6 and Figure F-7). If there is a communications problem between the LMF and any piece of test equipment, verify that the GPIB addresses have been set correctly and that the GPIB cables are firmly connected to the test equipment.

Figure F-13 shows the connections when *not using* an external 10 MHz Rubidium reference.

Figure F-13: Cable Connections for Test Set without 10 MHz Rubidium Reference

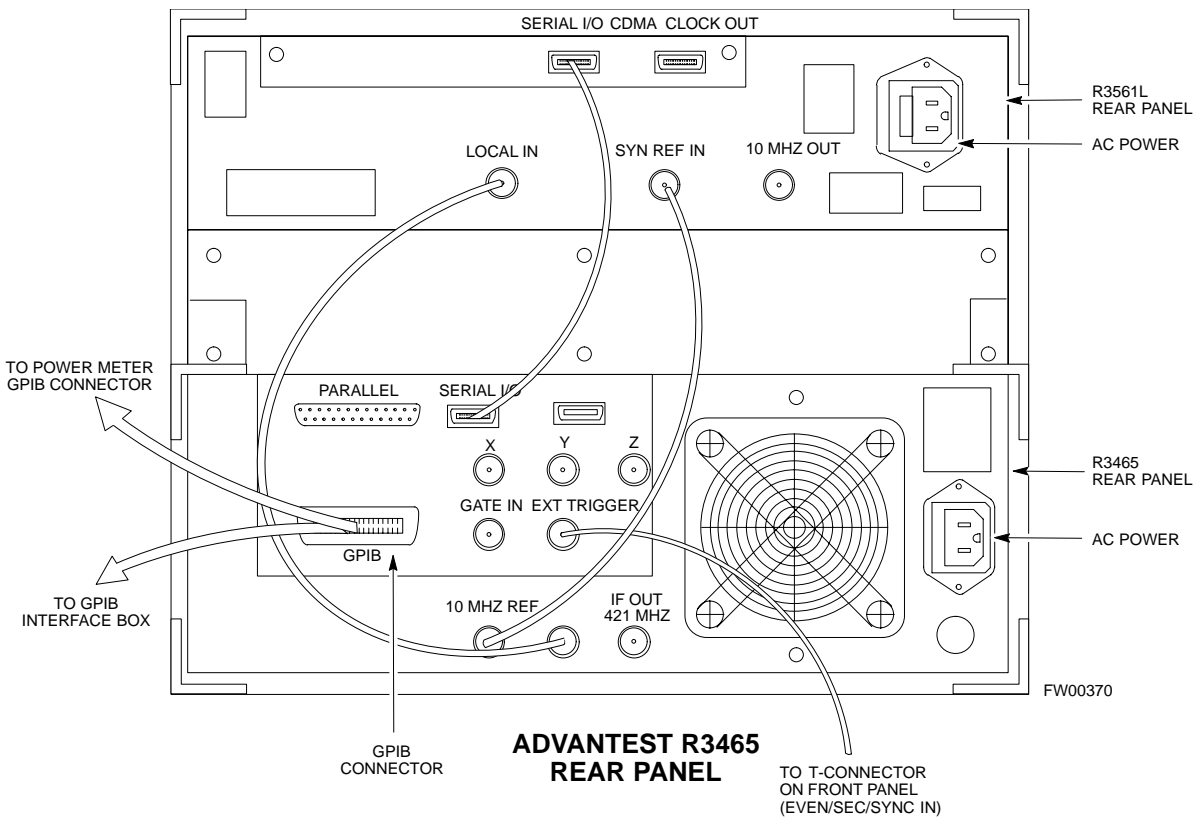

F

Figure F-14 shows the connections when *using* an external 10 MHz Rubidium reference.

Figure F-14: Cable Connections for Test Set with 10 MHz Rubidium Reference

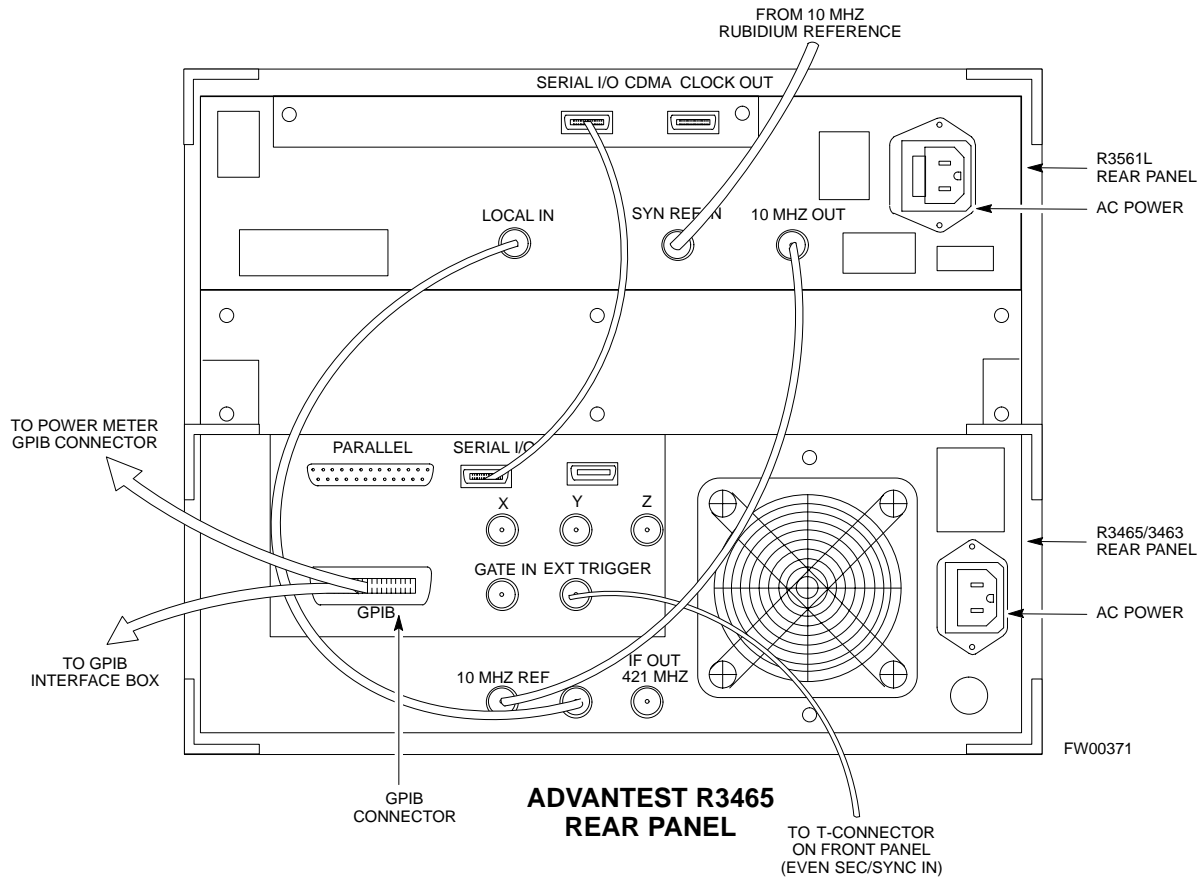

R3465 GPIB Clock Set-up

Table F-15 describes the steps to set the clock for the **Advantest R3465** equipment.

Table F-15: Advantest R3465 Clock Setup	
Step	Action
1	Observe the current date and time displayed in upper right of the CRT display.
2	If the date and time are incorrect, perform the following to change them:
2a	- Push the Date/Time CRT menu key.
2b	- Rotate the vernier knob to select and set.
2c	- Push the vernier knob to enter.
2d	- Push the SHIFT then PRESET pushbutton (just below the CRT display).



Pretest Setup for Advantest R3465

Before the Advantest R3465 analyzer is used for LMF-controlled testing it must be set up correctly for automatic testing.

Table F-16: Pretest Setup for Advantest R346

Step	Action
1	Press the SHIFT button so the LED next to it is illuminated.
2	Press the RESET button.

Agilent 8932/E4432B Test Equipment Interconnection

To perform FER testing on a 1X BTS with the Agilent 8935, a 1X-capable signal generator, such as the Agilent E4432B, must be used in conjunction with the CDMA base station test set. For proper operation, the test equipment items must be interconnected as follows:

10 MHz reference signal - Connect a BNC (M)-BNC (M) cable from the 8935 **10 MHz REF OUT** connector to the E4432B **10MHz IN** connector as shown in Figure F-15

Even second pulse reference - Refer to Figure F-15, and connect a BNC “T” connector to the 8935 **EVEN SEC SYNC IN** connector. Connect a BNC (M)-BNC (M) cable from one side of the BNC “T” to the E4432B **PATTERN TRIG IN** connector. Connect the other side of the BNC “T” to the CSM board **SYNC MONITOR** connector using a BNC (M)-BNC (M) cable.

Figure F-15: Agilent 8935/E4432B 10MHz Reference and Even Second Tick Connections

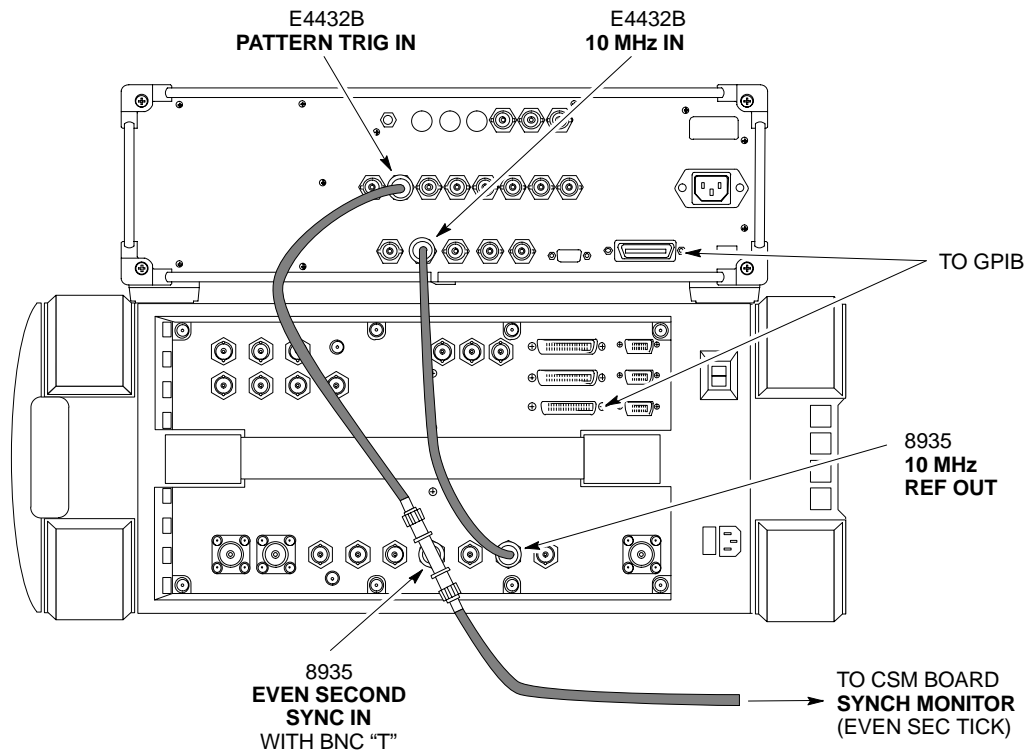

TDME0011-1

Agilent E4406A/E4432B Test Equipment Interconnection

To provide proper operation during testing when both units are required, the 10 MHz reference signal from the E4406A transmitter test set must be provided to the E4432B signal generator. Connect a BNC (M)-BNC (M) cable from the E4406A **10 MHz OUT (SWITCHED)** connector to the E4432B **10MHz IN** connector as shown in Figure F-16.

Figure F-16: Agilent 10 MHz Reference Connections

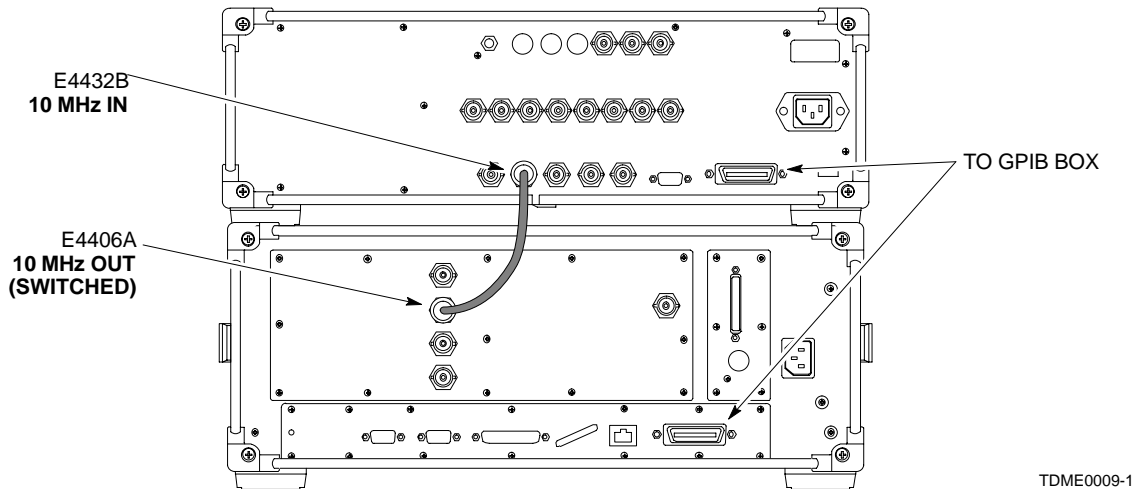

Advantest R3267/R3562 Test Equipment Interconnection

To provide proper operation during testing when both units are required, the R3257 spectrum analyzer must be interconnected with the R3562 signal generator as follows:

10 MHz reference signal - Connect a BNC (M)-BNC (M) cable between the R3562 **SYNTHE REF IN** connector and the R3267 **10 MHz OUT** connector as shown in Figure F-17.

Serial I/O - Using the Advantest cable provided, connect the R3267 **SERIAL I/O** connector to the R3562 **SERIAL I/O** connector as shown in Figure F-17.

Figure F-17: Advantest 10 MHz Reference and Serial I/O Connections

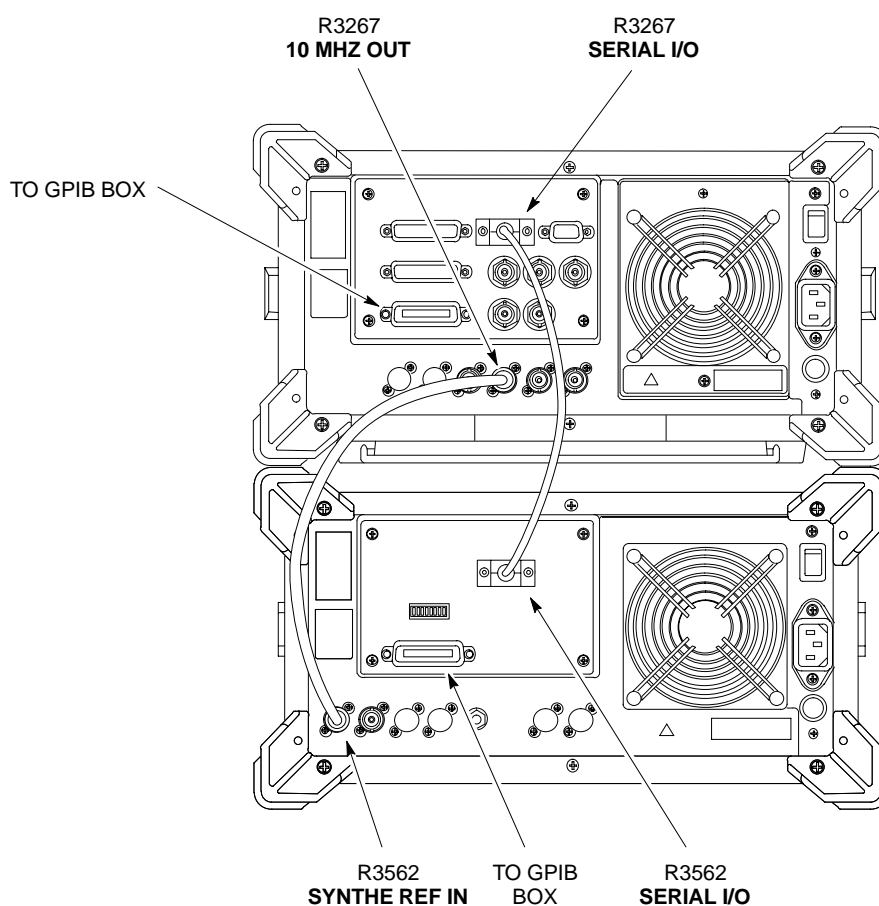

TDME0010-1

Equipment Calibration

Calibration Without the LMF

Several test equipment items used in the optimization process require pre-calibration actions or calibration verification which are not supported by the LMF. Procedures to perform these activities for the applicable test equipment items are covered in this section.

Agilent E4406A Transmitter Tester Self-alignment (Calibration)

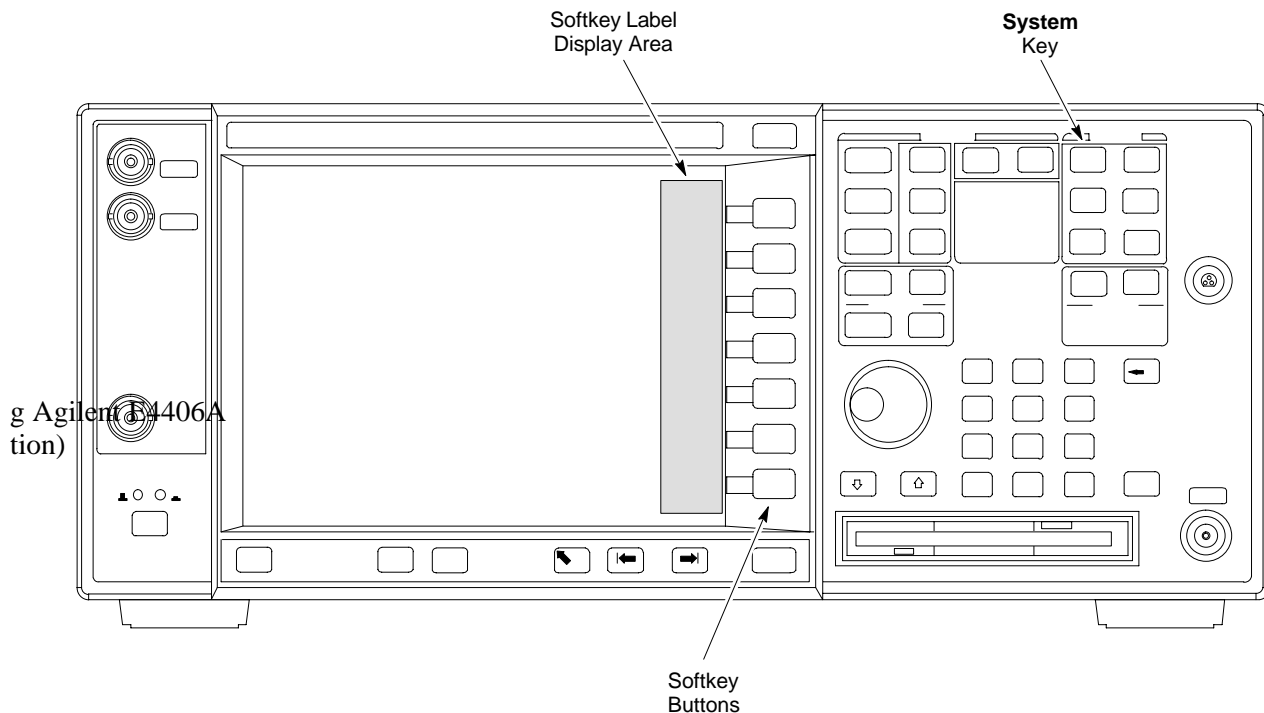

Refer to Figure F-18 and follow the procedure in Table F-17 to perform the Agilent E4406A self-alignment (calibration).

Table F-17: Perform Agilent E4406A Self-alignment (Calibration)

Step	Action
1	In the SYSTEM section of the instrument front panel, press the System key. <ul style="list-style-type: none"> - The softkey labels displayed on the right side of the instrument screen will change.
2	Press the Alignments softkey button to the right of the instrument screen. <ul style="list-style-type: none"> - The softkey labels will change.
3	Press the Align All Now softkey button. <ul style="list-style-type: none"> - All other instrument functions will be suspended during the alignment. - The display will change to show progress and results of the alignments performed. - The alignment will take less than one minute.

Calibrating HP 437 Power Meter

Precise transmit output power calibration measurements are made using a bolometer-type broadband power meter with a sensitive power sensor. Follow the steps outlined in Table F-18 to enter information unique to the power sensor before calibrating the test setup. Refer to Figure F-19 as required.

NOTE This procedure must be done *before* the automated calibration to enter power sensor specific calibration values.

Figure F-19: Power Meter Detail

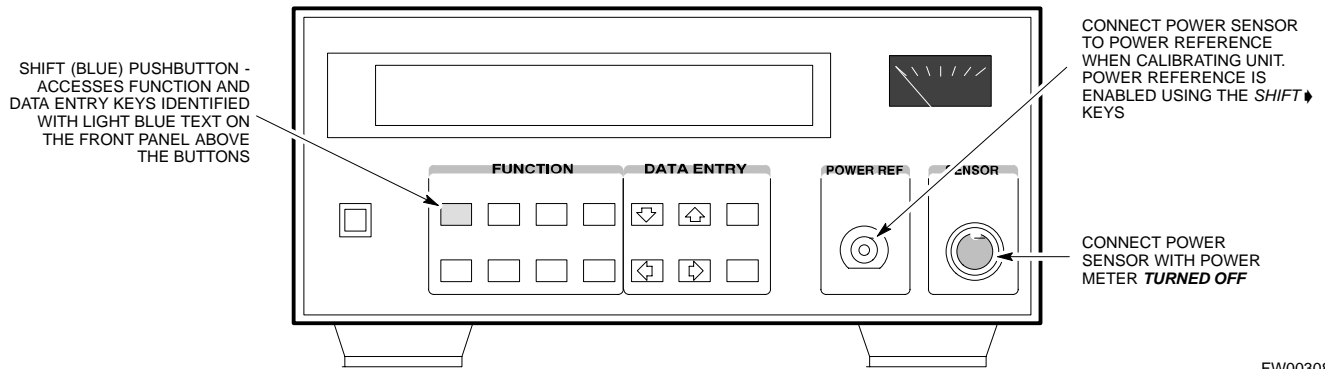

FW00308

Table F-18: HP 437 Power Meter Calibration Procedure

Step	Action
1	<p>! CAUTION</p> <p>Do not connect/disconnect the power meter sensor cable with AC power applied to the meter. Disconnection could result in destruction of the sensing element or mis-calibration.</p> <p>Make sure the power meter AC LINE pushbutton is OFF.</p>
2	Connect the power sensor cable to the SENSOR input.
3	Set the AC LINE pushbutton to ON .
	<p>NOTE</p> <p>The calibration should be performed only after the power meter and sensor have been allowed to warm-up and stabilize for a <i>minimum of 60 minutes</i>.</p>
4	Perform the following to set or verify the correct power sensor model:
4a	- Press [SHIFT] then [RIGHT ARROW] to select SENSOR .
4b	- Identify the power sensor model number from the sensor label.
4c	- Use the [UP ARROW] or [DOWN ARROW] button to select the appropriate model; then press [ENTER].
5	Refer to the illustration for step 8, and perform the following to ensure the power reference output is OFF :
5a	- Observe the instrument display and determine if the triangular indicator over PWR REF is displayed.
5b	- If the triangular indicator is displayed, press [SHIFT] then [RIGHT ARROW] to turn it off.

... continued on next page

Table F-18: HP 437 Power Meter Calibration Procedure

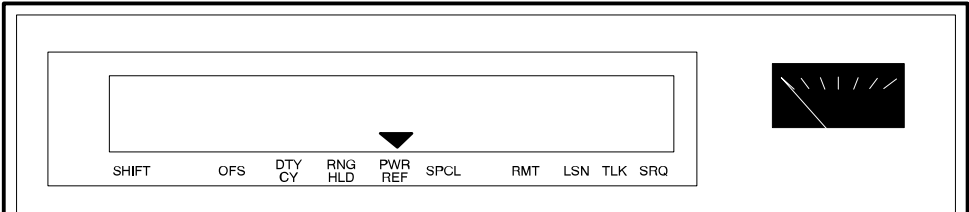
Step	Action
6	Press [ZERO] . <ul style="list-style-type: none"> - Display will show “Zeroing *****.” - Wait for process to complete.
7	Connect the power sensor to the POWER REF output.
8	Turn on the PWR REF by performing the following:
8a	- Press [SHIFT] then [▶] .
8b	- Verify that the triangular indicator (below) appears in the display above PWR REF . <div style="text-align: center; margin: 10px 0;">  </div>
9	Perform the following to set the REF CF% :
9a	- Press ([SHIFT] then [ZERO]) for CAL .
9b	- Enter the sensor’s REF CF% from the sensor’s decal using the arrow keys and press [ENTER] . (The power meter will display “CAL *****” for a few seconds.) <p>NOTE If the REF CAL FACTOR (REF CF) is not shown on the power sensor, assume it to be 100%.</p>
10	Perform the following to set the CAL FAC % :
10a	- Press [SHIFT] then [FREQ] for CAL FAC .
10b	- On the sensor’s decal, locate an approximate calibration percentage factor (CF%) at 2 GHz.
10c	- Enter the sensor’s calibration % (CF%) using the arrow keys and press [ENTER] . <ul style="list-style-type: none"> -- When complete, the power meter will typically display 0.05 dBm. (Any reading between 0.00 and 0.10 is normal.)
11	To turn off the PWR REF , perform the following:
11a	- Press [SHIFT] then [▶] .
11b	- Disconnect the power sensor from the POWER REF output.



Calibrating Gigatronics 8541C Power Meter

Precise transmit output power calibration measurements are made using a bolometer-type broadband power meter with a sensitive power sensor. Follow the steps in Table F-19 to enter information unique to the power sensor.

Table F-19: Calibrate Gigatronics 8541C Power Meter	
Step	Action
1	<p>! CAUTION</p> <p>Do not connect/disconnect the power meter sensor cable with AC power applied to the meter. Disconnection could result in destruction of the sensing element or miscalibration.</p> <p>Make sure the power meter POWER pushbutton is OFF.</p>
2	Connect the power sensor cable to the SENSOR input.
3	<p>Set the POWER pushbutton to ON.</p> <p>NOTE</p> <p>Allow the power meter and sensor to warm up and stabilize for a <i>minimum of 60 minutes</i> before performing the calibration procedure.</p>
4	Connect the power sensor to the CALIBRATOR output connector.
5	<p>Press ZERO.</p> <ul style="list-style-type: none"> - Wait for the process to complete. Sensor factory calibration data is read to power meter during this process.
6	When the zeroing process is complete, disconnect the power sensor from the CALIBRATOR output.

Figure F-20: Gigatronics 8541C Power Meter Detail

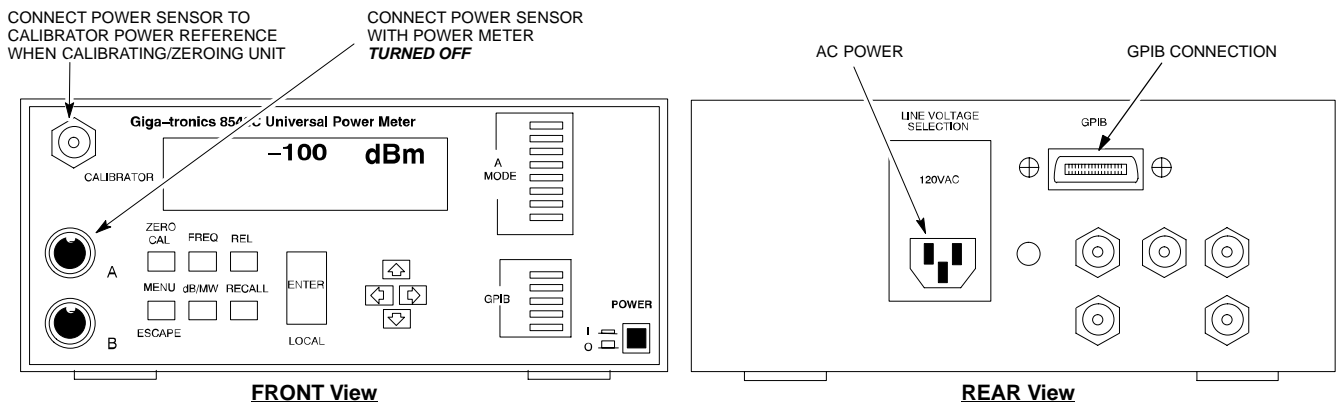

FW00564

Manual Cable Calibration

Calibrating Test Cable Setup Using HP PCS Interface (HP83236)

Table F-20 covers the procedure to calibrate the test equipment using the HP8921 Cellular Communications Analyzer equipped with the HP83236 PCS Interface.

NOTE	This calibration method <i>must be executed with great care</i> . Some losses are measured close to the minimum limit of the power meter sensor (-30 dBm).
-------------	--

Prerequisites

Ensure the following prerequisites have been met before proceeding:

- Test equipment to be calibrated has been connected correctly for cable calibration.
- Test equipment has been selected and calibrated.

Table F-20: Calibrating Test Cable Setup (using the HP PCS Interface)

Step	Action		
	NOTE Verify that GPIB controller is turned off.		
1	Insert HP83236 Manual Control System card into memory card slot.		
2	Press the Preset pushbutton.		
3	Under Screen Controls , press the TESTS pushbutton to display the TESTS (Main Menu) screen.		
4	Position the cursor at Select Procedure Location and select it. In the Choices selection box, select CARD .		
5	Position the cursor at Select Procedure Filename and select it. In the Choices selection box, select MANUAL .		
6	Position the cursor at RUN TEST and select it. HP must be in Control Mode Select YES .		
7	<table border="0" style="width: 100%;"> <tr> <td style="width: 50%; vertical-align: top;"> If using HP83236A: Set channel number=<chan#>: - Position cursor at Channel Number and select it. - Enter the <i>chan#</i> using the numeric keypad; press [Enter] and the screen will go blank. - When the screen reappears, the <i>chan#</i> will be displayed on the channel number line. </td> <td style="width: 50%; vertical-align: top;"> If using HP83236B: Set channel frequency: - Position cursor at Frequency Band and press Enter. - Select User Defined Frequency. - Go Back to Previous Menu. - Position the cursor to 83236 generator frequency and enter actual RX frequency. - Position the cursor to 83236 analyzer frequency and enter actual TX frequency. </td> </tr> </table>	If using HP83236A : Set channel number=<chan#>: - Position cursor at Channel Number and select it. - Enter the <i>chan#</i> using the numeric keypad; press [Enter] and the screen will go blank. - When the screen reappears, the <i>chan#</i> will be displayed on the channel number line.	If using HP83236B : Set channel frequency: - Position cursor at Frequency Band and press Enter . - Select User Defined Frequency . - Go Back to Previous Menu . - Position the cursor to 83236 generator frequency and enter actual RX frequency. - Position the cursor to 83236 analyzer frequency and enter actual TX frequency.
If using HP83236A : Set channel number=<chan#>: - Position cursor at Channel Number and select it. - Enter the <i>chan#</i> using the numeric keypad; press [Enter] and the screen will go blank. - When the screen reappears, the <i>chan#</i> will be displayed on the channel number line.	If using HP83236B : Set channel frequency: - Position cursor at Frequency Band and press Enter . - Select User Defined Frequency . - Go Back to Previous Menu . - Position the cursor to 83236 generator frequency and enter actual RX frequency. - Position the cursor to 83236 analyzer frequency and enter actual TX frequency.		
8	Set RF Generator level: - Position the cursor at RF Generator Level and select it. - Enter -10 using the numeric keypad; press [Enter] and the screen will go blank. - When the screen reappears, the value -10 dBm will be displayed on the RF Generator Level line.		

. . . continued on next page

Table F-20: Calibrating Test Cable Setup (using the HP PCS Interface)

Step	Action
9	Set the user fixed Attenuation Setting to 0 dBm : <ul style="list-style-type: none"> - Position cursor at Analyzer Attenuation and select it - Position cursor at User Fixed Atten Settings and select it. - Enter 0 (zero) using the numeric keypad and press [Enter].
10	Select Back to Previous Menu .
11	Record the HP83236 Generator Frequency Level: Record the HP83236 B Generator Frequency Level: <ul style="list-style-type: none"> - Position cursor at Show Frequency and Level Details and select it. - Under HP83236 Frequencies and Levels, record the Generator Level. - Under HP83236B Frequencies and Levels, record the Generator Frequency Level (1850 - 1910 MHz). - Position cursor at Prev Menu and select it.
12	Click on Pause for Manual Measurement .
13	Connect the power sensor directly to the <i>RF OUT ONLY</i> port of the PCS Interface.
14	On the HP8921A, under To Screen , select CDMA GEN .
15	Move the cursor to the Amplitude field and click on the Amplitude value.
16	Increase the Amplitude value until the power meter reads 0 dBm ±0.2 dB . NOTE The Amplitude value can be increased coarsely until 0 dBm is reached; then fine tune the amplitude by adjusting the Increment Set to 0.1 dBm and targeting in on 0 dBm.
17	Disconnect the power sensor from the <i>RF OUT ONLY</i> port of the PCS Interface. NOTE The Power Meter sensor's lower limit is -30 dBm. Thus, only components having losses ≤30 dB should be measured using this method. For further accuracy, always re-zero the power meter before connecting the power sensor to the component being calibrated. After connecting the power sensor to the component, record the calibrated loss immediately.
18	Disconnect all components in the test setup and calibrate each one separately by connecting each component, one-at-a-time, between the <i>RF OUT ONLY PORT</i> and the power sensor. Record the calibrated loss value displayed on the power meter. <ul style="list-style-type: none"> • Example: (A) Test Cable(s) = -1.4 dB (B) 20 dB Attenuator = -20.1 dB (B) Directional Coupler = -29.8 dB
19	After all components are calibrated, reassemble all components together and calculate the total test setup loss by adding up all the individual losses: <ul style="list-style-type: none"> • Example: Total test setup loss = -1.4 -29.8 -20.1 = -51.3 dB. This calculated value will be used in the next series of tests.
20	Under Screen Controls press the TESTS button to display the TESTS (Main Menu) screen.
21	Select Continue (K2) .
22	Select RF Generator Level and set to -119 dBm.

... continued on next page

Table F-20: Calibrating Test Cable Setup (using the HP PCS Interface)

Step	Action
23	Click on Pause for Manual Measurement .
24	Verify the HP8921A Communication Analyzer/83203A CDMA interface setup is as follows (fields not indicated remain at default): <ul style="list-style-type: none"> • Verify the GPIB (HP-IB) address: <ul style="list-style-type: none"> - under To Screen, select More - select IO CONFIG - Set HP-IB Adrs to 18 - set Mode to Talk&Lstn • Verify the HP8921A is displaying frequency (instead of RF channel) <ul style="list-style-type: none"> - Press the blue [SHIFT] button, then press the Screen Control [DUPLEX] button; this switches to the CONFIG (CONFIGURE) screen. - Use the cursor control to set RF Display to Freq
25	Refer to Chapter 3 for assistance in setting the cable loss values into the LMF.

Figure F-21: Cable Calibration Using HP8921 with PCS Interface

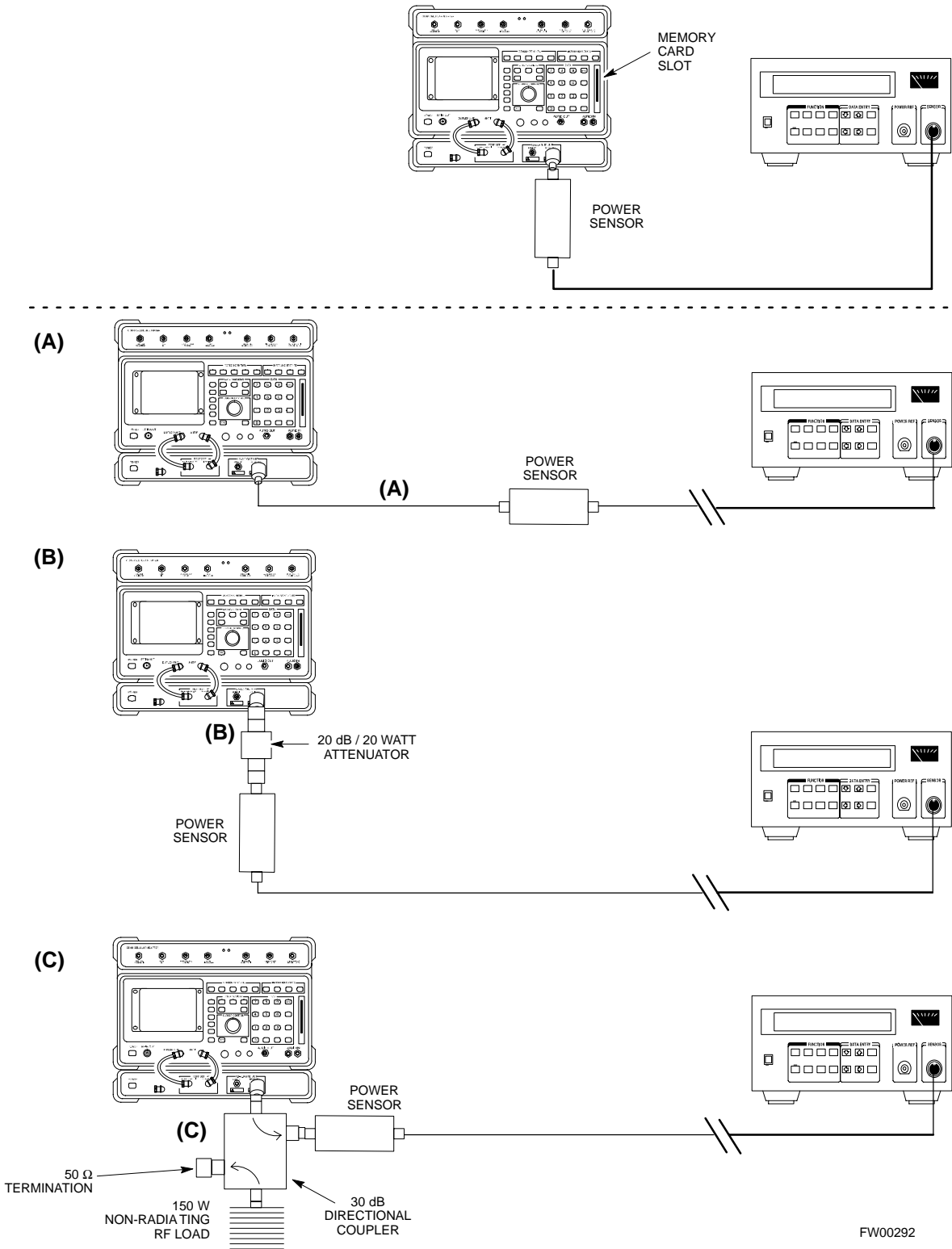

F

Calibrating Test Cable Setup Using Advantest R3465

NOTE	Be sure the GPIB Interface is OFF for this procedure.
-------------	---

Advantest R3465 Manual Test setup and calibration must be performed at both the TX and RX frequencies.

Table F-21: Procedure for Calibrating Test Cable Setup Using Advantest R3465

Step	Action
	<p>* IMPORTANT</p> <ul style="list-style-type: none"> - This procedure can only be performed <i>after</i> test equipment has been allowed to warm-up and stabilize for a <i>minimum of 60 minutes</i>.
1	Press the SHIFT and the PRESET keys located below the display
2	Press the ADVANCE key in the MEASUREMENT area of the control panel.
3	Select the CDMA Sig CRT menu key
4	Select the Setup CRT menu key
5	Using the vernier knob and the cursor keys set the following parameters NOTE Fields not listed remain at default Generator Mode: SIGNAL Link: FORWARD Level Unit: dBm CalCorrection: ON Level Offset: OFF
6	Select the return CRT menu key
7	Press FREQ key in the ENTRY area
8	Set the frequency to the desired value using the keypad entry keys
9	Verify that the Mod CRT menu key is highlighting OFF; if not, press the Mod key to toggle it OFF.
10	Verify that the Output CRT menu key is highlighting OFF; if not, press the Output key to toggle it OFF.
11	Press the LEVEL key in the ENTRY area.
12	Set the LEVEL to 0 dBm using the key pad entry keys.
13	Zero power meter. Next connect the power sensor directly to the "RF OUT" port on the R3561L CDMA Test Source Unit.
14	Press the Output CRT menu key to toggle Output to ON.
15	Record the power meter reading _____

... continued on next page

F

Table F-21: Procedure for Calibrating Test Cable Setup Using Advantest R3465

Step	Action
16	Disconnect the power meter sensor from the R3561L RF OUT jack. * IMPORTANT The Power Meter sensor's lower limit is -30 dBm. Thus, only components having losses ≤ 30 dB should be measured using this method. For best accuracy, always re-zero the power meter before connecting the power sensor to the component being calibrated. Then, after connecting the power sensor to the component, record the calibrated loss immediately.
17	Disconnect all components in the the test setup and calibrate each one separately. Connect each component one-at-a-time between the "RF OUT" port and the power sensor (see Figure F-22, "Setups A, B, and C"). Record the calibrated loss value displayed on the power meter for each connection. Example: (A) 1st Test Cable = -0.5 dB (B) 2nd Test Cable = -1.4 dB (C) 20 dB Attenuator = -20.1 dB (D) 30 dB Directional Coupler = -29.8 dB
18	Press the Output CRT menu key to toggle Output OFF.
19	Calculate the total test setup loss by adding up all the individual losses: Example: Total test setup loss = 0.5 + 1.4 + 20.1 + 29.8 = 51.8 dB This calculated value will be used in the next series of tests.
20	Press the FREQ key in the ENTRY area
21	Using the keypad entry keys, set the test frequency to the RX frequency
22	Repeat steps 9 through 19 for the RX frequency.
23	Refer to Chapter 3 for assistance in setting the cable loss values into the LMF.

Figure F-22: Cable Calibration Using Advantest R3465

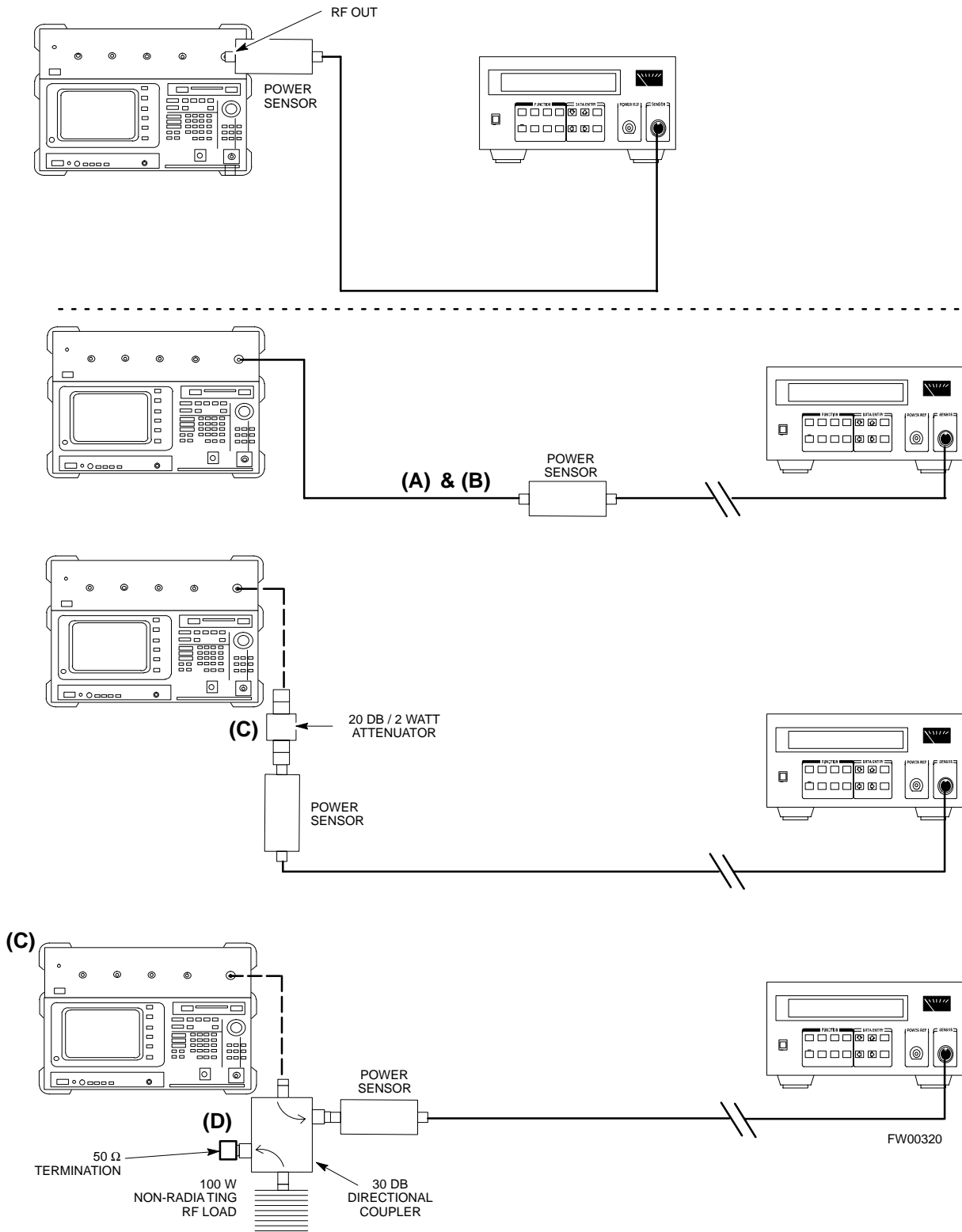

F

Appendix G

Download ROM Code

Downloading ROM Code

Exception Procedure - Downloading ROM Code

This procedure is not part of a normal optimization.

Perform this procedure only on an exception basis when no alternative exists to load a BTS device with the correct version of ROM code.

NOTE One GLI must be INS_ACT (bright green) before ROM code can be downloaded to non-GLI devices.

CAUTION The correct ROM and RAM codes for the software release used on the BSS must be loaded into BTS devices. To identify the correct device ROM and RAM code loads for the software release being used on the BSS, refer to the Version Matrix section of the SC™ CDMA Release Notes (supplied on the tapes or CD-ROMs containing the BSS software).

All devices in a BTS must be loaded with the ROM and RAM code specified for the software release used on the BSS before any optimization or ATP procedures can be performed.

If a replacement device is loaded with ROM code which is not compatible with the BSS software release being used, the device ROM code can be changed using the LMF before performing the BTS optimization and ATPs. *A device loaded with later release ROM code can not be converted back to a previous release ROM code in the field without Motorola assistance*

If it is necessary to download ROM code to a device from the LMF, the procedure in Table G-1 includes steps *for both ROM and RAM code download using the LMF.*

Prerequisites

Prior to performing this procedure, ensure the correct ROM and RAM code files exist in the LMF computer's applicable `<x>:\<lmf home directory>\cdma\loads\<code load#>\code` folder for each of the devices to be loaded (refer to Table 3-3).

CAUTION The Release level of the ROM code to be downloaded must be the one specified for the software release installed in the BSS. The release level of the ROM code resident in the other devices in the BTS must also be correct for the BSS software release being used. ROM code must not be downloaded to a frame loaded with code for a BSS software release with which it is not compatible.

This procedure should only be used to upgrade replacement devices for a BTS. It should NOT be used to upgrade all devices in a BTS. If a BTS is to be upgraded from R15.x to R16.0, the upgrade should be done by the OMC-R using the DownLoad Manager.



Table G-1: Download ROM and RAM Code to Devices

Step	Action
1	Click on the device to be loaded. NOTE More than one device of the <i>same</i> type can be selected for download by either clicking on each one to be downloaded or from the BTS menu bar Select pull-down menu, select the <i>device</i> item that applies. Where: <i>device</i> = the type of device to be loaded (BBX, CSM, GLI, MCC)
2	From the BTS menu bar Device pull-down menu, select Status . - A status report window will appear.
3	Make a note of the number in the HW Bin Type column. NOTE “HW Bin Type” is the Hardware Binary Type for the device. This code is used as the last four digits in the filename of a device’s binary ROM code file. Using this part of the filename, the ROM code file can be matched to the device in which it is to be loaded.
4	Click OK to close the status window.
5	Click on the device to be loaded.
6	NOTE ROM code is automatically selected for download from the <x>:\<lmf home directory>\<version folder>\<code folder> specified by the NextLoad property in the bts-#.cdf file. To check the value of the NextLoad property, click on Util > Examine > Display Nextload . A pop-up message will show the value of the NextLoad. From the BTS menu bar Device pull-down menus, select Download > ROM . - If the file matching the Hardware Binary Type of the device is found in the code folder, a status report shows the result of the download. Proceed to Step 11. - If a file selection window appears, select the ROM code file manually.
7	Double-click on the version folder with the desired version number for the ROM code file (for example 2.16.0.x).
8	Double-click the Code folder. - A list of ROM and RAM code files will be displayed.
9	! CAUTION A ROM code file with the correct HW Bin Type must be chosen. Using a file with the wrong HW Bin Type can result in unpredictable operation and damage to the device. Click on the ROM code file with the filename which matches the device type and HW Bin Type number noted in step 3 (for example, file bbx_rom.bin.0604 is the ROM code file for a BBX with a HW Bin Type of 0604). - The file should be highlighted.
10	Click on the Load button. - A status report window is displayed showing the result of the download. NOTE If the ROM load failed for some devices, load them <i>individually</i> by clicking on one device, perform steps 6 through 10 for it, and repeat the process for each remaining device.
11	Click OK to close the status window.

. . . continued on next page

Table G-1: Download ROM and RAM Code to Devices

Step	Action
12	From the LMF window menu bar Tools pull-down menus, select Update NextLoad > CDMA .
13	In the left-hand pane of the window which opens, click on the BTS number for the frame being loaded (for example, <i>BTS-14</i>).
14	On the list of versions displayed in the right-hand pane, click the button next to the version number of the folder that was used for the ROM code download (for example, <i>2.16.0.x</i>) and click Save . - A pop-up message will appear showing the CDF has been updated.
15	Click on the OK button to dismiss the pop-up message.
16	Click on the device that was loaded with ROM code.
17	NOTE RAM code is automatically selected for download. From the BTS menu bar Device pull-down menus, select Download > Code/Data to download RAM code and dds file data. - A status report is displayed showing the result of the download.
18	Click OK to close the status window.
19	Observe the downloaded non-GLI device to ensure it is OOS_RAM (yellow).
20	Click on the device which was loaded with code.
21	From the BTS menu bar Device pull-down menu, select Status . Verify that the correct ROM and RAM version numbers are displayed in the status report window.
22	Click OK to close the status window.



Appendix H

In-service Calibration

■
H
■

Introduction

Purpose

This procedure is a guide to performing calibration of new BTS expansion carriers while the system remains in service. This procedure also supports BTS recalibration following replacement of RF chain components while the remainder of the site stays in service.

Motorola recommends performing this procedure during a maintenance window.

This procedure cannot be performed on BTSs with 2-to-1 combiners. The procedure can only be performed on one carrier of the BTS at a time. That is, LPAs 1A, 1B, 1C, and 1D can be calibrated while LPAs 3A, 3B, 3C, and 3D remain in service and vice versa.

Equipment Stabilization and Calibration

NOTE	Calibration of the communications test set (or equivalent test equipment) <i>must be</i> performed at the site before calibrating the overall <i>test equipment set</i> . Calibrate the test equipment <i>after</i> it has been allowed to warm-up and stabilize for a <i>minimum of 60 minutes</i> .
-------------	---

CAUTION	If any component of the <i>test equipment set</i> (for example, a test cable, RF adapter, signal generator) has been replaced, the <i>test equipment set</i> must be recalibrated. Failure to do so could introduce measurement errors which ultimately result in degradation of system performance.
----------------	--

1X Test Equipment Requirements

In-Service Calibration (ISC) of 1X carrier functions requires using the following test equipment for the purposes indicated:

- An Advantest R3267 spectrum analyzer to perform TX calibration
- An Advantest R3562 signal generator for R3267 Delta Power Calibration
- An Agilent E4406A Transmitter Test Set to perform TX calibration
- An Agilent E4432A signal generator for E4406A Delta Power Calibration
- An Agilent 8935 series E6380A equipped with option 200 (if purchased new) or option R2K (if retrofitted) to perform TX calibration

The CDMA communications system analyzers listed above are capable of calibrating the BTS for both IS-95 A and B mode operation as well as CDMA2000 1X operation.

NOTE	IS-95A/B communication test sets such as the HP8921A/600 and Advantest R3561L <i>can not calibrate 1X carrier functions</i> .
-------------	---

Calibration and test set-up for the HP 8921A/600 and Advantest R3561L test sets is included only for situations where it is necessary to use them for calibration of IS-95A/B mode operation.

Power Delta Calibration

Introduction

The ISC procedure has several differences from a normal calibration procedure. One of these is the use of a spectrum analyzer/communications test set instead of a power meter to measure power. Power meters are broadband measurement devices and cannot be used to measure power during ISC because other carriers are operating. A spectrum analyzer can be used because it measures power at a given frequency. Measuring power using a spectrum analyzer is less accurate than using a power meter, therefore, compensation is required for the accuracy difference (delta) between the power meter and the spectrum analyzer.

Agilent E4406A Power Delta Calibration

The Agilent E4406A transmitter tester and E4432B signal generator test equipment combination can be used for ISC of IS-2000 CDMA 1X as well as IS-95A/B operation modes. The power delta calibration is performed on the E4406A, but the E4432B is required to generate the reference signal used to calculate the power delta offset. After the offset value has been calculated, add it to the TX cable loss value in the LMF.

Preliminary Agilent Test Equipment Set-up

To provide proper operation during power delta calibration, be sure the E4406A and E4432B are connected as shown in Figure F-16.

Power Delta Calibration

Follow the procedure in Table H-1 to perform the Agilent E4406A Power Delta Calibration procedure.

Table H-1: Agilent E4406A Power Delta Calibration Procedure	
Step	Action
	<p>NOTE Perform this procedure <i>after</i> test equipment has been allowed to warm-up and stabilize for a <i>minimum of 60 minutes</i>. After it is warmed up and stabilized, calibrate the test equipment as described in the “Test Set Calibration” section of Chapter NO TAG.</p>
1	<p>Zero the Power Meter prior to connecting the power sensor to the RF cable from the signal generator.</p> <p>NOTE For best accuracy, always re-zero the power meter before connecting the power sensor to the component being calibrated.</p>
2	Be sure the E4406A and E4432B are connected as shown in Figure F-16.
3	Connect a short RF cable from the E4432B RF OUTPUT connector the HP437 power meter power sensor (see Figure H-1).

. . . continued on next page



Table H-1: Agilent E4406A Power Delta Calibration Procedure

Step	Action
4	Set the E4432B signal generator as follows: <ul style="list-style-type: none"> - Press Preset to exit any modes for which the signal generator is configured - Press Frequency and enter the <i>frequency</i> of the channel to be calibrated on the numeric keypad - Using the soft keys to the right of the screen, select the frequency range to be measured; for example MHz - Press Amplitude and, using the numeric keypad, set signal amplitude to 0 (zero) - Using the soft keys, set the measurement type to dBm
5	On the E4432B, press RF On/Off to toggle the RF output to RF ON . <ul style="list-style-type: none"> - Note that the RF On/Off status in the screen display changes.
6	Measure and record the value reading on the HP437 power meter as result A _____.
7	On the E4432B, press RF On/Off to toggle the RF output to RF OFF . <ul style="list-style-type: none"> - Note that the RF On/Off status in the screen display changes.
8	Disconnect the short RF cable from the HP437 power meter power sensor, and connect it to the RF INPUT connector on the E4406A transmitter tester (see Figure H-2).
9	<p>NOTE</p> <p>Do not change the frequency and amplitude settings on the E4432B when performing the following steps.</p> <p>Set the E4406A as follows:</p> <ul style="list-style-type: none"> - Press Preset to exit any modes for which the transmitter tester is configured - Press MODE and, using the soft keys to the right of the screen, select cdmaOne - Press MEASURE and, using the soft keys, select spectrum - Press Frequency and, using the soft keys, select Center Frequency - Enter the <i>frequency</i> of the channel to be calibrated using the numeric keypad - Using the soft keys, select the frequency range to be measured; for example, MHz - Press Input/Output and, using the soft keys, select Input Atten - Using the numeric keypad, set Input Atten to 0 (zero) and, using the soft keys, select dB - Using the soft keys, select External Atten and then select Mobile - Using the numeric keypad, set Mobile to 0 (zero) and, using the soft keys, select dB - Using the soft keys, select Base - Using the numeric keypad, set Base to 0 (zero) and, using the soft keys, select dB - Press MEASURE and, using the soft keys, select Channel Power
10	On the E4432B signal generator, press RF On/Off to toggle the RF output to RF ON . <ul style="list-style-type: none"> - Note that the RF On/Off status in the screen display changes.
11	Read the measured Channel Power from the E4406A screen display and record it as result B _____.
12	On the E4432B, press RF On/Off to toggle the RF output to RF OFF . <ul style="list-style-type: none"> - Note that the RF On/Off status in the screen display changes.

. . . continued on next page

Table H-1: Agilent E4406A Power Delta Calibration Procedure	
Step	Action
13	<p>Calculate the Power Calibration Delta value. The delta value is the power meter measurement minus the Agilent measurement.</p> <p>Delta = A - B</p> <p>Example: Delta = -0.70 dBm - (-1.25 dBm) = 0.55 dBm</p> <p>Example: Delta = 0.26 dBm - 0.55 dBm = -0.29 dBm</p> <p>These examples are included to show the mathematics and do not represent actual readings.</p> <p>NOTE</p> <p>Add this delta value to the TX Cable Loss value during In-Service Calibration (see step 4 in Table H-6).</p>

Figure H-1: Delta Calibration Setup - Agilent E4432B to HP437

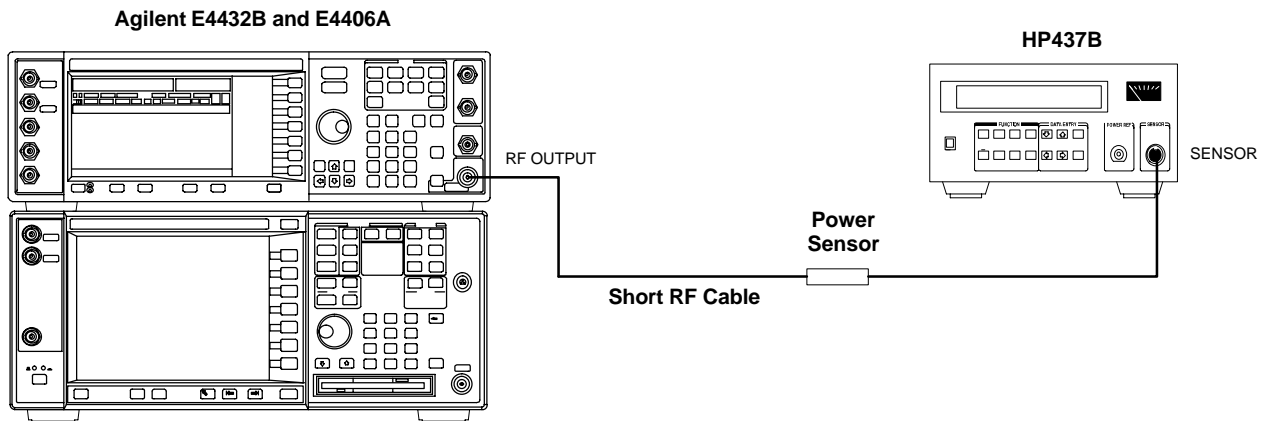
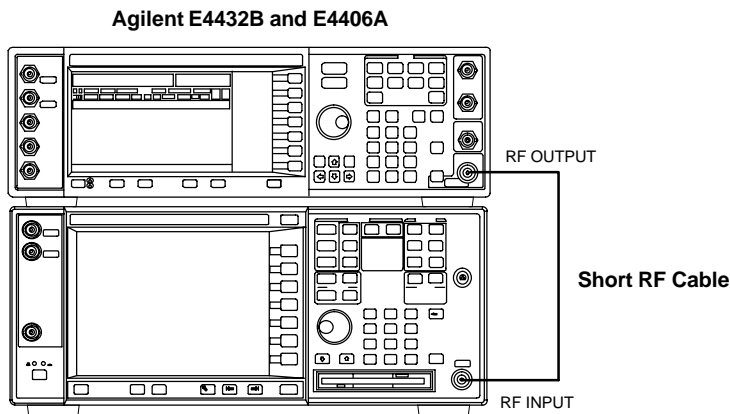

Figure H-2: Delta Calibration Setup - Agilent E4432B to Agilent E4406A



H

Advantest R3267 Power Delta Calibration

The Advantest R3267 spectrum analyzer and R3562 signal generator test equipment combination can be used for ISC of IS-2000 CDMA 1X as well as IS-95A/B operation modes. The power delta calibration is performed on the R3267. After the offset value has been calculated, add it to the TX cable loss value.

Preliminary Advantest Test Equipment Set-up

To provide proper operation during power delta calibration, be sure the R3267 is connected to the R3562 as shown in Figure F-17.

Power Delta Calibration

Follow the procedure in Table H-2 to perform the Advantest R3267 Power Delta Calibration procedure.

Table H-2: Advantest R3267 Power Delta Calibration Procedure

Step	Action
1	<p>NOTE Warm-up <i>test equipment for a minimum of 60 minutes</i> prior to this procedure. After it is warmed up and stabilized, calibrate the test equipment as described in the “Test Set Calibration” section of Chapter NO TAG.</p> <p>Be sure the R3267 and R3562 are connected as shown in Figure F-17.</p>
2	Press the SHIFT and the PRESET keys located on the right side of the control panel.
3	Press the ADVANCE key in the MEASUREMENT area of the control panel.
4	On the CRT, select RX Control by pressing ACTIVE key 1.
5	On the CRT, select Frequency Setup by pressing ACTIVE key 3.
6	On the CRT, highlight Frequency by adjusting the DISPLAY CONTROL knob.
7	Press FREQ key in the ENTRY section of the control panel.
8	Set the frequency to the desired value using the keypad ENTRY section keys.
9	Press the LEVEL key in the ENTRY section of the control panel.
10	Set the level to 0 dBm using the keypad ENTRY section keys.
11	On the CRT, verify OFF is highlighted in Modulation , if not press the ACTIVE key 5 to toggle it OFF.
12	On the CRT, verify OFF is highlighted in Output , if not press the ACTIVE key 6 to toggle it OFF.
13	Zero the Power Meter prior to connecting the power sensor to the RF cable from the signal generator.
	<p>NOTE For best accuracy, always re-zero the power meter before connecting the power sensor to the component being calibrated.</p>
14	Connect the RF cable from the R3562 signal generator RF OUT port to the power sensor, refer to Figure H-4.
15	On the R3562 CRT, set the Output to ON by pressing ACTIVE key 6.

. . . continued on next page

Table H-2: Advantest R3267 Power Delta Calibration Procedure

Step	Action
16	Record the Power Meter reading as result A _____
17	On the R3562 CRT, set the Output to OFF by pressing ACTIVE key 6.
18	Connect the RF cable from R3562 signal generator RF OUT port to the R3267 spectrum analyzer INPUT Port, refer to Figure H-5.
19	On the R3562 CRT, set the Output to ON by pressing ACTIVE key 6.
20	On the R3267, press the POWER key in the MEASUREMENT section of the control panel.
21	Press the LEVEL key in the ENTRY section of the control panel.
22	Set the REF LEVEL to 10 dBm using the keypad ENTRY section keys.
23	On the CRT, select dB/div by pressing ACTIVE key 1.
24	On the CRT, select 10 dB/div by pressing ACTIVE key 1.
25	Press the FREQ key in ENTRY section of the control panel.
26	Set the frequency to the desired value using the keypad ENTRY section keys.
27	On the CRT, select more 1/2 by pressing ACTIVE key 7.
28	Press the Preselector CRT menu key to highlight 3.66G .
29	Press the POWER key in the MEASUREMENT section of the control panel.
30	Press the SPAN key in the ENTRY section of the control panel.
31	On the CRT, select Zero Span by pressing ACTIVE key 2.
32	Press the COUPLE key in the ENTRY section of the control panel.
33	On the CRT, select RBW and highlight MNL by pressing ACTIVE key 3.
34	Set RBW to 30 kHz using keypad ENTRY section keys.
35	On the CRT, select VBW and highlight MNL by pressing ACTIVE key 2.
36	Set VBW to 1 MHz using keypad ENTRY section keys.
37	Press the MKR key in the DISPLAY CONTROL section of the control panel.
38	On the CRT, select Normal Marker by pressing ACTIVE key 1.
39	Record the Marker Level reading as result B _____
40	Press Single in ENTRY section of control panel.

. . . continued on next page



Table H-2: Advantest R3267 Power Delta Calibration Procedure	
Step	Action
41	<p>Calculate the Power Calibration Delta value. The delta value is the power meter measurement minus the Advantest measurement.</p> <p>Delta = A - B</p> <p>Example: Delta = -0.7 dBm - (-1.25 dBm) = 0.55 dB</p> <p>Example: Delta = 0.26 dBm - 0.55 dBm = -0.29 dBm</p> <p>These examples are included to show the mathematics and do not represent actual readings.</p> <p>NOTE</p> <p>Add this delta value to the TX Cable Loss value during In-Service Calibration (see step 4 in Table H-6).</p>

Figure H-3: Delta Calibration Setup - Advantest R3562 to HP437

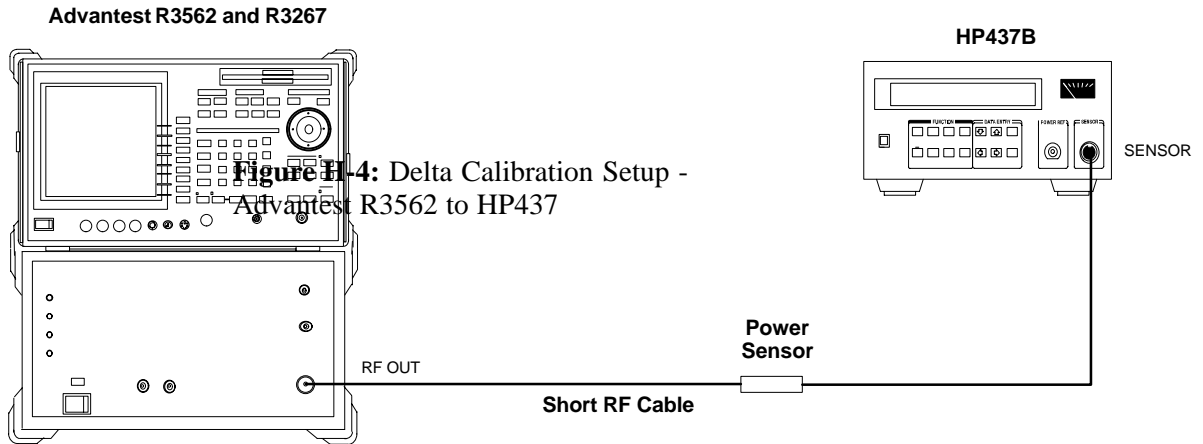
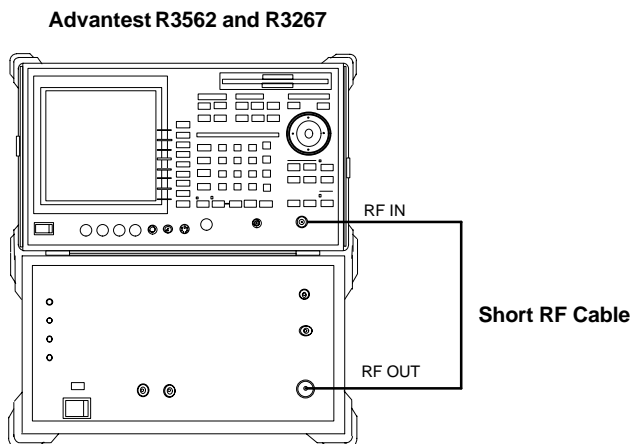

Figure H-4: Delta Calibration Setup - Advantest R3562 to HP437

Figure H-5: Delta Calibration Setup - Advantest R3562 to R3267



H

Agilent 8935 series E6380A Power Delta Calibration

The Agilent 8935 (formerly HP 8935) communications test set modified with either option 200 or R2K and E4432B signal generator test equipment combination can be used for ISC of IS-2000 CDMA 1X as well as IS-95A/B operation modes. The power delta calibration is performed on the Agilent 8935. After the offset value has been calculated, add it to the TX cable loss value.

Follow the procedure in Table H-3 to perform the Agilent 8935 Power Delta Calibration procedure.

Table H-3: Agilent 8935 Power Delta Calibration Procedure

Step	Action
	<p>NOTE</p> <p>Perform this procedure <i>after</i> test equipment has been allowed to warm-up and stabilize for a <i>minimum of 60 minutes</i>. After it is warmed up and stabilized, calibrate the test equipment as described in the “Test Set Calibration” section of Chapter NO TAG.</p>
1	<p>Zero the Power Meter prior to connecting the power sensor to the RF cable from the signal generator.</p> <p>NOTE</p> <p>For best accuracy, always re-zero the power meter before connecting the power sensor to the component being calibrated.</p>
2	Connect a short RF cable between the Agilent 8935 Duplex Out port and the HP437 power sensor (see Figure H-6).
3	<p>Set the Agilent 8935 signal source as follows:</p> <ul style="list-style-type: none"> - Measure mode to CDMA Gen - Frequency to the CDMA Calibration target frequency - CW RF Path to IQ - Output Port to Dupl - Data Source to Random - Amplitude to 0 dBm
4	Measure and record the power value reading on the HP437 Power Meter.
5	Record the Power Meter reading as result A _____.
6	<p>Turn off the Agilent 8935 signal source output, and disconnect the HP437.</p> <p>NOTE</p> <p>Leave the settings on the source Agilent 8935 for convenience in the following steps.</p>
7	Connect the short RF cable between the Agilent 8935 Duplex Out port and the RF-IN/OUT port (see Figure H-7).
8	Ensure that the source Agilent 8935 settings are the same as in Step 3.

... continued on next page

Table H-3: Agilent 8935 Power Delta Calibration Procedure	
Step	Action
9	Set the Agilent 8935 as follows: <ul style="list-style-type: none"> - Measure mode to CDMA Anl - Frequency to the CDMA calibration target frequency - Input Attenuation to 0 dB - Input port to RF-IN - Gain to Auto - Anl Dir to Fwd
10	Turn on the Agilent 8935 signal output.
11	Set the Chn Pwr Cal to Calibrate and select to calibrate.
12	Measure and record the channel power reading on the measuring Agilent 8935 as result B _____.
13	Turn off the Agilent 8935 signal output and disconnect the equipment.
14	Calculate the Power Calibration Delta value. The delta value is the power meter measurement minus the Advantest measurement. $\Delta = A - B$ Example: $\Delta = -0.70 \text{ dBm} - (-1.25 \text{ dBm}) = 0.55 \text{ dBm}$ Example: $\Delta = 0.26 \text{ dBm} - 0.55 \text{ dBm} = -0.29 \text{ dBm}$ These examples are included to show the mathematics and do not represent actual readings. NOTE Add this delta value to the TX Cable Loss value during In-Service Calibration (see Step 4 in Table H-6).

Figure H-6: Delta Calibration Setup - Agilent 8935 to HP437

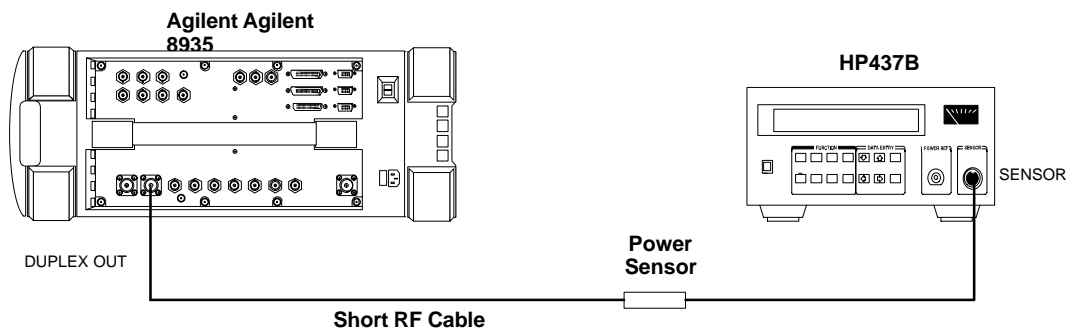

H

Figure H-7: Delta Calibration Setup - Agilent 8935 to Agilent 8935

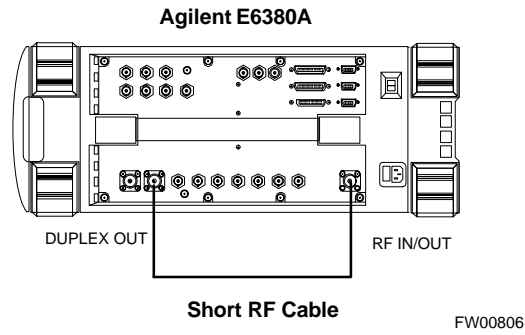

HP8921A Power Delta Calibration

Use the HP8921A communications test set to measure power during ISC *only for IS-95A and B operation* of 800 MHz systems. After the offset value has been calculated, add it to the TX cable loss value.

Follow the procedure in Table H-4 to perform the HP8921A Power Delta Calibration procedure.

NOTE This procedure requires two HP8921A communication test sets.

Table H-4: HP8921A Power Delta Calibration Procedure

Step	Action
	<p>NOTE Perform this procedure <i>after</i> test equipment has been allowed to warm-up and stabilize for a <i>minimum of 60 minutes</i>. After it is warmed up and stabilized, calibrate the test equipment as described in the “Test Set Calibration” section of Chapter NO TAG.</p>
1	<p>Zero the Power Meter prior to connecting the power sensor to the RF cable from the signal generator.</p> <p>NOTE For best accuracy, always re-zero the power meter before connecting the power sensor to the component being calibrated.</p>
2	<p>Connect a short RF cable between the HP8921A Duplex Out port and the HP437 power sensor (see Figure H-8).</p>
3	<p>Set the HP8921A signal source as follows:</p> <ul style="list-style-type: none"> - Measure mode to CDMA Generator - Frequency to the CDMA Calibration target frequency - CW RF Path to IQ - Output Port to Dupl - Data Source to Random - Amplitude to 0 dBm
4	<p>Measure and record the power value reading on the HP437 Power Meter.</p>
5	<p>Record the Power Meter reading as result A _____.</p>
6	<p>Turn off the source HP8921A signal output, and disconnect the HP437.</p> <p>NOTE Leave the settings on the source HP8921A for convenience in the following steps.</p>
7	<p>Connect the short RF cable between the source HP8921A Duplex Out port and the measuring HP8921A RF-IN port (see Figure H-9).</p>
8	<p>Ensure that the source HP8921A settings are the same as in Step 3.</p>

... continued on next page



Table H-4: HP8921A Power Delta Calibration Procedure	
Step	Action
9	Set the measuring HP8921A as follows: <ul style="list-style-type: none"> - Measure mode to CDMA AnI - Frequency to the CDMA calibration target frequency - Input Attenuation to 0 dB - Input port to RF-IN - Gain to Auto - Analyzer Direction to Fwd
10	Turn on the source HP8921A signal output.
11	Measure and record the channel power reading on the measuring HP8921A as result B _____.
12	Turn off the source HP8921A signal output and disconnect the equipment.
13	Compute the delta between HP437 and HP8921A using the following formula: $\text{Delta} = A - B$ Example: $\text{Delta} = -0.70 \text{ dBm} - (-1.25 \text{ dBm}) = 0.55 \text{ dBm}$ Example: $\text{Delta} = 0.26 \text{ dBm} - 0.55 \text{ dBm} = -0.29 \text{ dBm}$ These examples are included to show the mathematics and do not represent actual readings. NOTE Add this delta value to the TX Cable Loss value during In-Service Calibration (see Step 4 in Table H-6).

Figure H-8: Delta Calibration Setup - HP8921A to HP437

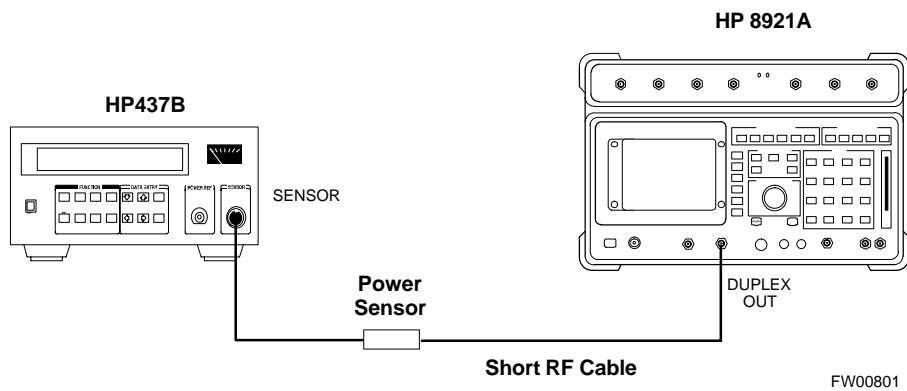
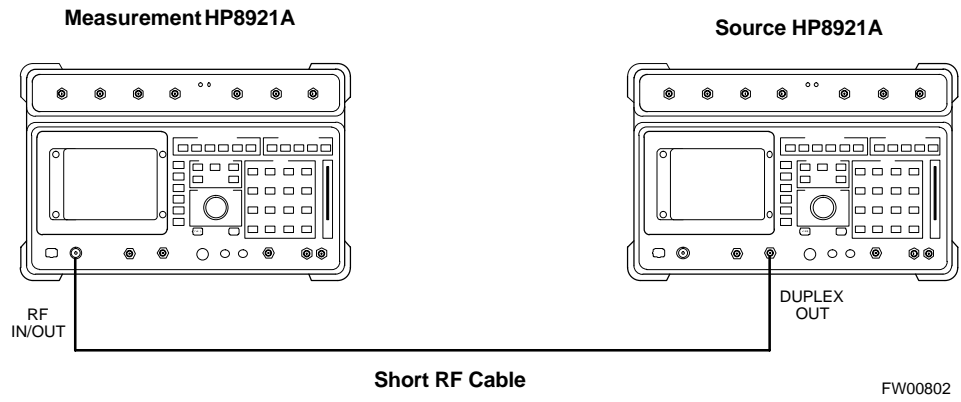

Figure H-9: Delta Calibration Setup - HP8921A to HP8921A



H

Advantest R3465 Power Delta Calibration

Use the Advantest R3465 spectrum analyzer to measure power during ISC *only for IS-95A and B operation*. After the offset value has been calculated, add it to the TX cable loss value.

Follow the procedure in Table H-5 to perform the Advantest 3465 Power Delta Calibration procedure.

Table H-5: Advantest Power Delta Calibration Procedure

Step	Action
	<p>NOTE</p> <p>Perform this procedure <i>after</i> test equipment has been allowed to warm-up and stabilize for a <i>minimum of 60 minutes</i>. After it is warmed up and stabilized, calibrate the test equipment as described in the “Test Set Calibration” section of Chapter NO TAG.</p>
1	Press the SHIFT and the PRESET keys located below the CRT display.
2	Press the ADVANCE key in the Measurement area of the control panel.
3	Press the CDMA Sig CRT menu key.
4	Press the FREQ key in the Entry area of the control panel.
5	Set the frequency to the desired value using the keypad entry keys.
6	Press the LEVEL key in the Entry area of the control panel.
7	Set the LEVEL to 0 dBm using the keypad entry keys.
8	Verify the Mod CRT menu key is highlighting OFF , if not press the Mod key to toggle it OFF .
9	Verify the Output CRT menu key is highlighting OFF , if not press the Output key to toggle it OFF .
10	<p>Zero the Power Meter prior to connecting the power sensor to the RF cable from the signal generator.</p> <p>NOTE</p> <p>For best accuracy, always re-zero the power meter before connecting the power sensor to the component being calibrated.</p>
11	Connect the RF cable from the R3561L CDMA signal generator RF OUT port to the power sensor, refer to Figure H-10.
12	Press the Output CRT menu key to toggle the Output to ON .
13	Record the Power Meter reading as result A _____.
14	Press the Output CRT menu key to toggle the Output to OFF .
15	Connect the RF cable from the R3561L signal generator RF OUT port to the R3465 INPUT Port, refer to Figure H-11.
16	Press the Output CRT menu key to change the Output to ON .
17	Press the CW key in the Measurement area of the control panel.
18	Press the LEVEL key in the Entry area of the control panel.
19	Set the REF LEVEL to 10 dBm using the keypad entry keys.
20	Press the dB/div CRT menu key.
21	Press the 10 dB/div CRT menu key.

. . . continued on next page

Table H-5: Advantest Power Delta Calibration Procedure

Step	Action
22	Press the FREQ key in Entry area of the control panel.
23	Set the frequency to the desired value using the keypad entry keys.
24	Press the more 1/2 CRT menu key.
25	Press the Preselector CRT menu key to highlight 3.0G .
26	Press the FORMAT key in the Display Control area of the control panel.
27	Press the TRACE CRT menu key.
28	Press the AVG A CRT menu key.
29	Set AVG to 20 using keypad entry keys.
30	Press the return CRT menu key.
31	Press the SPAN key in the Entry area of the control panel.
32	Press the Zero Span CRT menu key.
33	Press the BW key in the Entry area of the control panel.
34	Press the RBW CRT menu key to highlight MNL . using keypad entry keys enter 30 kHz .
35	Set RBW to 30 kHz using keypad entry keys.
36	Press the VBW CRT menu key to highlight MNL .
37	Set VBW to 1 MHz using keypad entry keys.
38	Press the Marker ON key in the Display Control area of the control panel.
39	Record the Marker Level reading as result B _____.
40	<p>Calculate the Power Calibration Delta value. The delta value is the power meter measurement minus the Advantest measurement.</p> <p style="padding-left: 40px;">Delta = A - B</p> <p style="padding-left: 40px;">Example: Delta = -0.70 dBm - (-1.25 dBm) = 0.55 dBm</p> <p style="padding-left: 40px;">Example: Delta = 0.26 dBm - 0.55 dBm = -0.29 dBm</p> <p>These examples are included to show the mathematics and do not represent actual readings.</p> <p>NOTE</p> <p>Add this delta value to the TX Cable Loss value during In-Service Calibration (see Step 4 in Table H-6).</p>



Figure H-10: Delta Calibration Setup - R3561L to HP437

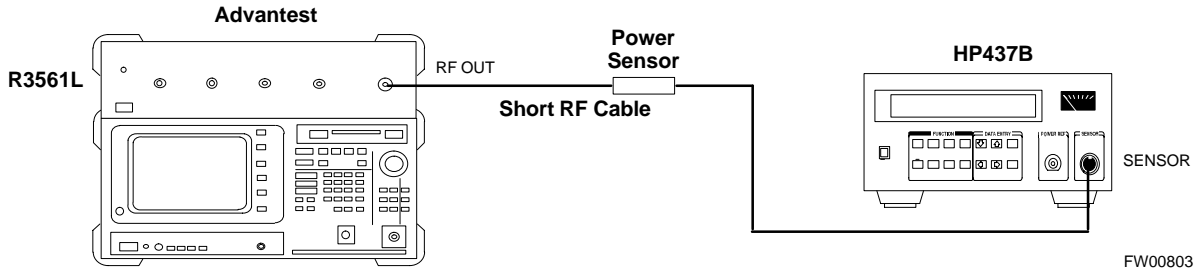
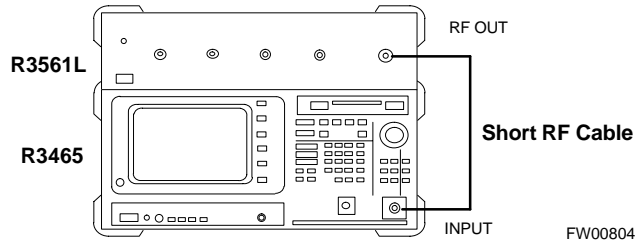

Figure H-11: Delta Calibration Setup - R3561L to R3465



In-Service Calibration

CAUTION

This feature does NOT have fault tolerance at this time. *The system has no safe-guards to prevent actions which will put the BTS out of service.* If possible, perform this procedure during a maintenance window.

Follow the procedures in this section precisely, otherwise the entire BTS will most likely go OUT OF SERVICE.

At the CBSC, only perform operations on expansion hardware when it is in the OOS_MANUAL state.

The operator must be trained in the LMF operation prior to performing this procedure.

Prerequisites

- Any applicable expansion hardware has been added in the CBSC database, and a CDF which includes the additions has been generated.
- Any expansion devices have been inserted into the SCCP cage and are in the OOS_MANUAL state at the CBSC MM.
- The site specific CDF (with any expansion hardware) and CAL files have been loaded onto the LMF.
- The LMF has the same device binary code and dds files as the CBSC.

CAUTION

Do not download code or data to any cards other than those being worked on. Downloading code or data to other cards will take the site OUT OF SERVICE.

The code file version numbers must match the current BSS software release version numbers required for the equipped devices (refer to Table 3-3). If the numbers do not match, the site may go OUT OF SERVICE.

It is *mandatory* that the **bts-#.cdf** and **cbsc-#.cdf** files on the LMF computer for this BTS are copies of the corresponding files created in the CBSC database (see Table 3-2).

The CAL file loaded on the LMF computer for this BTS must have come from the CBSC.

- Test equipment has been connected as shown in Figure H-12 or Figure H-13.
- An RFDS (or as a minimum, a directional coupler), whose loss is already known, must be in the applicable TX antenna path to perform the in-service calibration.
- Test equipment has been calibrated after a 60-minute warm up.
- A short RF cable and two BNC-N adapters are available to perform Cable Calibration.
- N-SMA cable adapters are available to connect to TRDC or DRDC **BTS CPLD** connectors, and are included in cable loss measurements.

- The Power Delta Calibration has been performed (see Table H-1, Table H-2, Table H-3, Table H-4, or Table H-5).

Figure H-12: TX Calibration Test Setup - Agilent E4406A, Advantest R3267, and Agilent 8935 with Option 200 or R2K (IS-95A/B and 1X CDMA 2000)

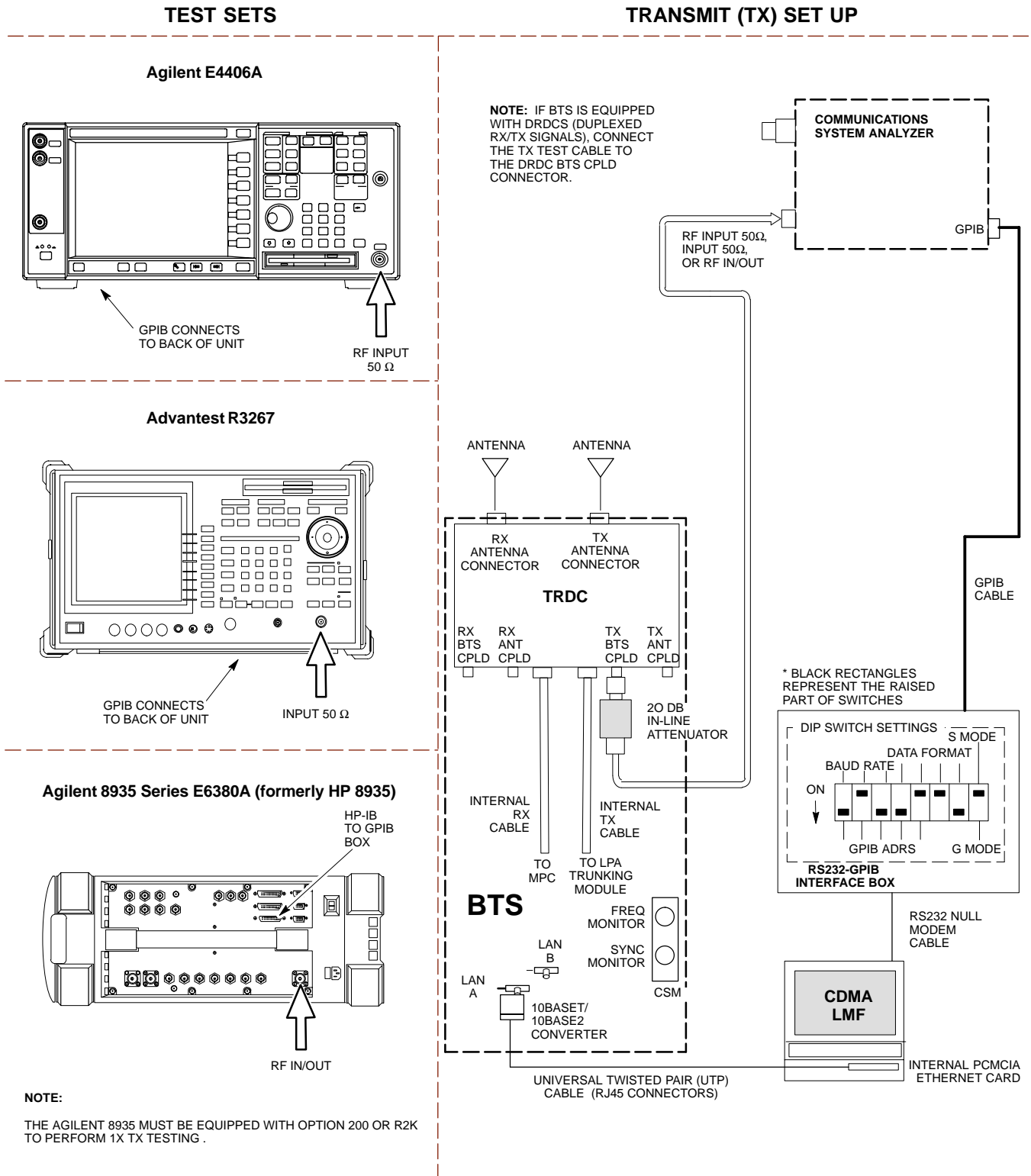
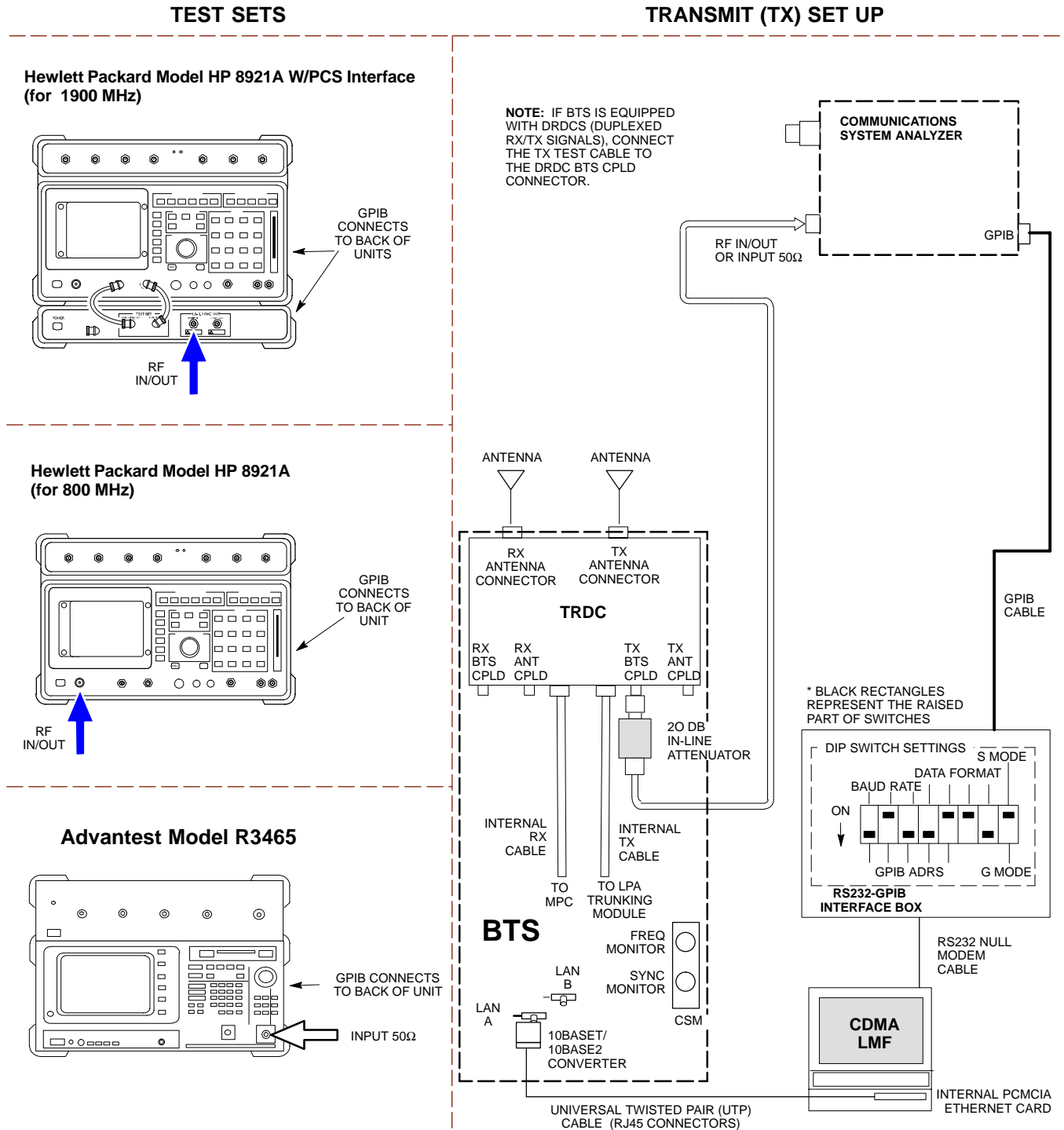

Figure H-13: TX Calibration Test Setup - HP 8921A/600 w/PCS Interface (1.9 GHz), HP 8921A/600 (800 MHz), and Advantest R3465 (IS-95A/B only)



H

Follow the procedure in Table H-6 to perform the In-Service Calibration.

Table H-6: In-Service Calibration	
Step	Action
	<p>NOTE Perform this procedure <i>after</i> test equipment has been allowed to warm-up and stabilize for a <i>minimum of 60 minutes</i>.</p>
1	<p>Set up the LMF for In-Service Calibration:</p> <ul style="list-style-type: none"> - Start the LMF by double-clicking the LMF icon on the Windows desktop. - Click Tools > Options from the menu bar at the LMF application window. - In the LMF Options window, check only the applicable communications system analyzer check box on the Test Equipment tab. - Ensure that the GPIB address is 18. - Uncheck any other other equipment that is selected. - Click the Apply button. - Select the BTS Options tab in the LMF Options window. - Check the In-Service Calibration check box. - Click the Apply button. - Click the Dismiss button to close the LMF Option window.
2	<p>Log into the target BTS:</p> <ul style="list-style-type: none"> - Select the target BTS icon. - Click the Login button at the login screen.
3	<p>Measure the Cable Loss using the Cable Calibration function:</p> <ul style="list-style-type: none"> - Click Util > Cable Calibration... in the BTS menu bar at the main window. - Set the desired channel(s) and select TX and RX CABLE CAL from the Cable Calibration window drop-down list. - Click the OK button to perform cable calibration. - Follow the on-screen instructions to complete the cable loss measurement. <p>NOTE</p> <ul style="list-style-type: none"> - The measured value is input automatically to the cable loss file. - To view the cable loss file, click Util > Examine > Cable Loss from the BTS menu bar.
4	<p>Add the communications system analyzer power delta to the TX Cable Loss.</p> <ul style="list-style-type: none"> - In the BTS menu bar, click Util > Edit > Cable Loss... > TX. - Add the value computed in Table H-4, Table H-5, or Table H-3 to the TX Cable Loss. <p>NOTE</p> <p>Be sure to include the sign of the value. The following examples are included to show the mathematics and do not represent actual readings:</p> <ul style="list-style-type: none"> - Example: 5.65 dBm + 0.55 dBm = 6.20 dBm - Example: 5.65 dBm + (-0.29 dBm) = 5.36 dBm - Example: -5.65 dBm + 0.55 dBm = -5.10 dBm - Example: -5.65 dBm + (-0.29 dBm) = -5.94 dBm

. . . continued on next page



Table H-6: In-Service Calibration

Step	Action
5	Input the Coupler Loss for the TX tests: <ul style="list-style-type: none"> - In the BTS menu bar, click Util > Edit > Coupler Loss... from the menu bar at the main window. - Select the TX Coupler Loss tab if not in the foreground. - Enter the appropriate coupler loss for the target carrier(s) by referring to the information taken at the time of BTS installation. - Click the Save button. - Click the Dismiss button to close the window. - To view the coupler loss file, click Util > Examine > Coupler Loss in the BTS menu bar.
6	Input the Coupler Loss for the RX tests: <ul style="list-style-type: none"> - In the BTS menu bar, click Util > Edit > Coupler Loss... from the menu bar at the main window. - Select the RX Coupler Loss tab if not in the foreground. - Enter the appropriate coupler loss for the target carrier(s) by referring to the information taken at the time of BTS installation. - Click the Save button. - Click the Dismiss button to close the window. - To view the couper loss file, click Util > Examine > Coupler Loss in the BTS menu bar.
7	If it was not previously done, have the CBSC operator put the redundant BBX OOS_MANUAL.
8	<p>! CAUTION</p> <p>Be sure to download OOS devices only. Loading in-service devices takes them OUT OF SERVICE and can result in dropped calls.</p> <p>The code file version numbers must match the version numbers on the other cards in the frame. If the numbers do not match, the site may go OUT OF SERVICE.</p> <p>NOTE</p> <p>Be sure to include the redundant BBX in steps 8, 9, and 10.</p> <p>Download code and data to the target devices:</p> <ul style="list-style-type: none"> - In the LMF window menu bar, click Tools > Update NextLoad > CDMA to set the code version that will be downloaded. - Check the appropriate code version in the popup window and click the Save button to close. - Select the target BBX(s) on the SCCP cage picture. - In the BTS menu bar, click Device > Download > Code/Data to start downloading code and data.

. . . continued on next page

Table H-6: In-Service Calibration

Step	Action
9	<p>! CAUTION</p> <p>Perform the All Cal/Audit procedure on OOS devices only.</p> <p>Run the All Cal/Audit procedure:</p> <ul style="list-style-type: none"> - Select the target BBX(s) on the SCCP cage picture. - In the BTS menu bar, click Tests > All Cal/Audit... from the menu bar at the main window. - Select the target carrier and confirm the channel number in the pop up window. - Leave the Verify BLO check box checked. - Be sure the Test Pattern box shows Pilot. - Click the OK button to start calibration. - Follow the on-screen instructions, except, <i>do not connect to the BTS antenna port</i>. Connect to the DRDC or TRDC BTS CPL port associated with the on-screen prompted antenna port.
10	<p>Save the result, and download the BLO data to the target BBX(s):</p> <ul style="list-style-type: none"> - Click the Save Result button on the result screen. -- The window closes automatically.
11	<p>Logout from the BTS and close the LMF session:</p> <ul style="list-style-type: none"> - In the BTS menu bar, click Select > Logout to close the BTS connection. - Close the LMF application program by selecting File > Exit from the window menu bar.
12	<p>Disconnect all test cables from the BTS, and reconnect RFDS cables or termination loads, as applicable, to the DRDC or TRDC BTS CPL ports used for the calibration.</p>
13	<p>Advise the CBSC to enable the target device(s).</p>
14	<p>Restore the new "bts-*.cal" file to the CBSC (refer to Table 5-2).</p>

Notes

Lined area for notes, consisting of multiple horizontal lines.





Index

Numbers

- 10 MHz Rubidium Standard, optional test equipment, 1-11
- 10BaseT/10Base2 converter
 - LMF to BTS connection, 3-22
 - remove from BTS, 5-4
- 2:1 combiners, description, 1-20
- 2:1 TX combiner location, 1-30
- 2-way splitter, optional test equipment, 1-11
- 20-pair punchblock
 - description, 1-20
 - location, 1-20
 - punchdowns, 3-20
- 50-pair punchblock
 - description, 1-21
 - location, 1-21, 3-17
 - RGPS punchdowns
 - non-expansion frame, 3-19
 - primary expansion frame, 3-20
 - secondary expansion frame, 3-19

A

- Abbreviated
 - RX acceptance test, all-inclusive, 4-8
 - TX acceptance test, all-inclusive, 4-8
- Acceptance Test Procedure. *See* ATP
- ACTIVE LED
 - GLI, 6-30
 - MCC, 6-32
- Advantest R3465, setting GPIB address, F-8
- Agilent E4406A, calibration, F-24
- Alarm and Span Line Cable Pin/Signal Information, 3-17
- ALARM LED, GLI, 6-30
- Alarm Monitor window, 3-103
- Alarm Reporting Display, 3-103
- All Cal/Audit procedure, 3-86
- All RX ATP Test Procedure, 4-11
- All tests fail on a single antenna, Troubleshooting, RFDS, 6-26
- All TX ATP Test Procedure, 4-10
- All TX/RX ATP Test Procedure, 4-9
- Applying AC Power, 2-12

ATP

- all inclusive TX acceptance test outline, 4-8
- automated introduction, 4-1
- code domain noise floor acceptance test procedure, 4-23
- code domain power acceptance test procedure, 4-23
- failure report generation, 4-27
- FER test, frame error rate testing, 4-25
- pilot time offset, 4-20
- prerequisites, 4-2
- spectral purity TX mask, 4-16
- test matrix/detailed optimization, B-1
- test set-up, 3-61
 - Advantest R3267/R3562
 - DRDCs, 3-64
 - TRDCs, 3-66
 - Advantest R3465, 3-61
 - Agilent 8935, DRDCs, 3-61
 - Agilent 8935/E4432B, DRDCs, 3-63, 3-65
 - Agilent E4406A/E4432B
 - DRDCs, 3-63
 - TRDCs, 3-65
 - CyberTest, 3-61
 - HP 8921A, 1.9 GHz, 3-62
 - HP 8921A, 800 MHz, 3-62
 - waveform quality (Rho), 4-18
 - waveform quality (RHO) acceptance test procedure, 4-18
- ATP - Reduced, 4-1
- Attenuator, required test equipment, 1-9

B

- Basic Troubleshooting Overview, 6-1
- Battery Charge Test (Connected Batteries), 2-15
- Battery Discharge Test, 2-16
- Bay Level Offset calibration
 - description, 3-78
 - purpose, 3-78
 - when to calibrate, 3-79
- Bay Level offset calibration failure, 6-9
- BBX
 - carrier spectral purity, 4-15
 - gain set point vs SIF output considerations, C-1
 - primary and redundant, TX tests to be performed, 4-13
- BBX LED status combinations, 6-32
- BBX2 Connector, 6-19
- BLO. *See* Bay Level Offset calibration
- Bringing modules into service, prepare to leave the site, 5-4

Broad Band Receiver. *See* BBX

BTS

- download, 3-33
- Ethernet LAN interconnect diagram, 3-30
- LMF connection, 3-15, 3-22
- log out of session, 5-4
- RX sensitivity/frame error rate, 4-14
- system software download, 3-3

BTS Frame Erasure Rate. *See* FER

BTS Log In Procedure, GUI, 3-24

BTS login

- CLI environment, 3-26
- General, 3-24
- GUI environment, 3-24

BTS Logout

- CLI environment, 3-28
- GUI environment, 3-27

Create CAL File, 3-92

bts-nnn.cal File, 3-11

C

cable calibration, automatic, test set-up, 3-55, 3-56

- Advantest R3267/R3562, 3-56
- Advantest R3465, 3-55
- Agilent 8935, 3-55
- Agilent E4406A/E4432B, 3-56, 3-57
- CyberTest, 3-55
- HP 8921A, 3-55

CAL file. *See* calibration data file

Calibrating Cables, 3-71

Calibrating Test Cable Setup, PCS Interface
HP83236B, F-28

Calibrating Test Equipment, 3-71

Calibration, In-Service, H-20

calibration

- calibration data file, 3-79
- Gigatronics 8542B, F-27

Calibration Audit failure, 6-10

calibration data file, description of, 3-79

Cannot communicate to Communications Analyzer,
6-6

Cannot communicate to Power Meter, 6-5

Cannot Download DATA to any device card, 6-7

Cannot ENABLE device, 6-8

Cannot Log into cell-site, 6-2

Cannot perform carrier measurement, 6-15

Cannot perform Code Domain Noise Power
measurement, 6-15

Cannot perform Rho or pilot time offset
measurement, 6-14

Cannot perform Txmask measurement, 6-14

cbsc folder, 3-11

CDF

- site configuration, 3-2
- site equipage verification, 3-3
- site type and equipage data information, 2-1

CDMA

- allocation diagram for the North American, cellular
telephone frequency spectrum, D-4
- optimization/ATP test matrix, B-1
- subscriber mobile radiotelephone, optional test
equipment, 1-11

cdma Folder, 3-10

Cell Site

- equipage verification, 2-1
- types configuration, 3-2

Cell Site Data File. *See* CDF

Channel Service Unit, 3-15

CIO Connectors, 6-20

Clock Sync Module. *See* CSM

Code domain power/noise floor
acceptance test, 4-23
analyzer display, 4-24

code Folder, 3-12

Communication test set, rear panel, F-14, F-16

Communications test set. *See* Test equipment

communications test set, TX acceptance tests, 4-6

Connect BTS E1/T1 spans, 5-5

Connect BTS T1/E1 spans, 5-5

Connecting test equipment to the BTS, 3-50

Connector Functionality

- Backplane, Troubleshooting, 6-19
- Troubleshooting, Backplane, 6-19

Control, TX output verification, 4-6

Copy CBSC CDF Files to the LMF, 3-5

Copying CAL files from CDMA LMF to the CBSC,
5-1

Copying CAL files to the CBSC, 5-1

CSM

- clock source, select, 3-36

- enable, 3-37
 - system description, 3-40
- CSM clock source, select, 3-36
- CSM frequency verification, 3-42
- CSM LED Status Combinations, 6-28
- D**
- data Folder, 3-13
- DC Power Pre-test (BTS Frame), 2-7
- DC Power Problems, SCCP Backplane Troubleshooting, 6-23
- DC/DC Converter LED Status Combinations, 6-27
- Detailed, optimization/ATP test matrix, B-1
- Devices, download. *See* Download
- Digital Control Problems, 6-21
 - SCCP Backplane Troubleshooting, 6-21
- Digital multimeter, required test equipment, 1-9
- Directional coupler, required test equipment, 1-9
- diversity receive path, definition, 3-78
 - companion frame, 3-78
 - stand-alone frame, 3-78
- diversity RX path. *See* diversity receive path
- Documents, required, 1-12
- Download
 - See also* Devices
 - BTS, 3-33
 - BTS system software, 3-3
- Download BLO Procedure, 3-89
- Download from the CBSC, prepare to leave the site, 5-3
- download ROM and RAM code. *See* ROM code
- Download/Enable MCCs, 3-39
- Download/Enable MGLIs, 3-35
- Duplexer, optional test equipment, 1-10
- E**
- E1, isolate BTS from the E1 spans, 3-14
- E4406A
 - calibration, F-24
 - setting GPIB address, F-2
- E4432B, setting GPIB address, F-3
- Enable CSMs. *See* CSM
- End LMF session, 5-4
- Equipment Overview, 1-16
- Equipment warm-up, 3-54
- establish MMI communication, 3-28
- Ethernet LAN
 - interconnect diagram, 3-30
 - transceiver, 1-7
- Ethernet LAN termination, 2-3
- Every test fails, Troubleshooting, RFDS, 6-25
- F**
- Failure report generation, 4-27
- FER, acceptance test, 4-25
- Files, intermediate file, 4-27
- files, calibration data, 3-79
- Filtronics, low IM Duplexer (Cm035-f2) or equivalent, optional test equipment, 1-10
- Fluke, model 8062A with Y8134 test lead kit, test equipment, 1-9
- Folder Structure Overview, 3-10
- Foreword, xviii
- forward link problem after passing reduced ATP, 6-14
- Frame, equipage preliminary operations, 2-1
- FREQ Monitor Connector, CSM, 6-29
- Frequency counter, optional test equipment, 1-10
- G**
- Gain set point, C-1
- General Safety, xxiii
- Generating an ATP Report, 4-27
- General optimization checklist, test data sheets, A-4
- Gigatronics 8541C, setting GPIB address, F-11
- Gigatronics 8542 power meter, calibration, F-27
- GLI Connector, 6-19
- GLI Ethernet A and B Connections, 6-19
- GLI LED Status Combinations, 6-30
- GLI Pushbuttons and Connectors, 6-31
- GLI2 Front Panel Operating Indicators, 6-31
- GPIB, F-13, F-17, F-19
 - cables, 1-9
 - HP8935, F-6
 - interface adapter, switch settings, F-12

set address, F-2
 Advantest R3267, F-4
 Advantest R3465, F-8
 Advantest R3562, F-5
 Agilent 8935, F-6
 Agilent E4406A, F-2
 Agilent E4432B, F-3
 Gigatronics 8542B, F-11
 HP 437B, F-10
 HP 8921, F-7
 HP83236A/B, F-7
 Motorola CyberTest, F-9

GPIO box, switch settings, F-12

GPS, receiver operation, test data sheets, A-5

GPS Initialization/Verification
 estimated position accuracy, 3-43
 surveyed position accuracy, 3-43

GPS satellite system, 3-38

Group Line Interface. *See* GLI

H

Hardware Requirements, 1-6

High Stability 10 MHz Rubidium Standard, optional test equipment, 1-11

High-impedance conductive wrist strap, required test equipment, 1-10

HP 437
 Pre-calibration, F-25
 setting GPIB address, F-10

HP 83236A, F-17

HP 8921A PCS interface, Cables Connection for 10 MHz Signal and GPIB , F-14, F-16

HP 8921A/600 test set, 1-8

HP83236A/B, setting GPIB address, F-7

HP 8921A, setting GPIB address, F-7

HP8921A, F-17
 Test equipment connections , F-13

HP8935, GPIB, F-6

HSO Initialization/Verification, 3-41

Huber & Suhner, required test equipment, 1-9

HyperTerminal, Creating named HyperTerminal connection, 3-8

HyperTerminal , create named connection, 3-8

I

I and Q values, E-1

In-Service Calibration, H-20
 preliminary Agilent test equipment set-up, H-2, H-5
 test set-up diagrams
 DRDC, Advantest, 3-64
 TRDC, Advantest, 3-66

Initial HP8921A setup, F-28

Initial Installation of Boards/Modules, preliminary operations, 2-1

Initial power tests, test data sheets, A-3

Intermediate file, generate ATP file using, 4-27

IS-97 specification, E-1

L

LAN, optional test equipment, 1-10

LAN connectors, external, 2-3

LAN termination, 2-3

LED Status Combinations for all Modules except GLI2 CSM BBX2 MCC24 MCC8E, 6-27

LFR, receiver operation, test data sheets, A-6

LMF, F-13, F-19
 1X FER acceptance test, 4-6
 1X upgrade preparation
 checking for required HW Bin files, 3-7
 home directory, 3-5
 BTS connection, 3-22
 logout procedure, 5-4
 platform requirements, 1-6
 remove from BTS, 5-4
 terminal, 1-6
 to BTS connection, 3-14, 3-15
 TX acceptance tests, 4-6
 view CDF information, 3-3

LMF BTS displays, 3-23

lmf Folder, 3-10

loads folder, 3-11

Local Maintenance Facility. *See* LMF

Log out
 of BTS, 5-4
 of LMF PC, 5-4

Logging Into a BTS, 3-24

Logging Out, 3-27

logical BTS numbering, 1-16

LORAN-C Initialization/Verification, 3-48
 LPA errors, 6-8
 LPA Module LED, 6-33
 LPA Shelf LED Status Combinations, 6-33

M

Master Group Line Interface. *See* MGLI
 MASTER LED, GLI, 6-30
 MCC LED Status Combinations, 6-32
 MMI common connections, 3-29
 MMI Connector
 CSM, 6-29
 GLI, 6-31
 MMI Connectors, MCC, 6-32
 MMI equipment setup, 3-29
 Module status indicators, 6-27
 Motorola CyberTest, setting GPIB address, F-9
 Multi Channel Card. *See* MCC
 Multi-FER test Failure, 6-16

N

New installations, 1-4
 No AMR control, 6-21
 No BBX2 control in the shelf, 6-22
 No DC input voltage to Power Supply Module, 6-23
 No DC voltage +5 +65 or +15 Volts to a specific
 GLI2 BBX2 or Switch board, 6-24
 No GLI2 Control through span line connection, 6-21
 No GLI2 Control via LMF, 6-21
 No or missing MCC24 channel elements, 6-22
 No or missing span line traffic, 6-22
 North American, cellular telephone system frequency
 spectrum, CDMA allocation, D-4

O

Online Help, 3-29
 optimization/ATP, test set-up
 HP 8921A, 800 MHz, H-19
 HP 8921A, 1.9 GHz, H-19
 Optional test equipment, 1-10
 10 MHz rubidium standard, 1-11

2-way splitter, 1-11
 CDMA subscriber mobile or portable
 radiotelephone, 1-11
 duplexer, 1-10
 frequency counter, 1-10
 LAN tester, 1-10
 oscilloscope, 1-11
 RF circular, 1-11
 RF test cable, 1-11
 spectrum analyzer, 1-10
 Oscilloscope, optional test equipment, 1-11

P

Patent Notification, xxvi
 PCMCIA, Ethernet adapter
 LMF to BTS connection, 3-22
 remove from BTS, 5-4
 Periodic optimization, 1-4
 Pilot Time Offset. *See* PN
 Pilot time offset, acceptance test, 4-20
 Ping, 3-30
 PN
 offset programming information, E-1
 offset usage, E-1
 PN offset per sector, E-1
 PN Offset Usage , E-1
 power
 applying, 2-20
 AC, 2-20
 DC, 2-21
 removal, 2-18
 AC power, 2-19
 DC power, 2-18
 Power Delta Calibration
 Advantest, H-14
 Agilent 8935, H-8
 HP8921A, H-11
 Power Input, 6-19
 Power Meter, setting GPIB address, HP437B, F-10
 Power meter
 required test equipment, 1-9
 setting GPIB address, Gigatronics 8542B, F-11
 TX acceptance tests, 4-6
 Power Supply Module Interface, 6-19
 power-up, BTS. *See* power, applying
 Pre-calibration, HP 437, F-25

- Pre-power tests, test data sheets, A-3
- Preliminary operations
 - cell Site types, 2-1
 - test data sheets, A-2
- Prepare to leave site
 - connect BTS E1/T1 spans, 5-5
 - connect BTS T1/E1 spans, 5-5
 - remove external test equipment, 5-3
- Prepare to leave the site
 - bringing modules into service, 5-4
 - download code and data from CBSC, 5-3
- Prerequisites, automated acceptance tests, 4-2
- Procedures to Copy CAL Files From Diskette to the CBSC, 5-1, 6-7
- Procedures to Copy Files to a Diskette, 5-1
- Pseudorandom Noise. *See* PN
- PWR/ALM and ACTIVE LEDs, MCC, 6-32
- PWR/ALM LED
 - BBX-1X, 6-32
 - BBX2, 6-32
 - CSM, 6-28
 - DC/DC Converter, 6-27
 - generic, 6-27
 - MCC, 6-32
- R**
- R3267, setting GPIB address, F-4
- R3562, setting GPIB address, F-5
- RAM code, described, 3-33
- receive path
 - calibration, 3-78
 - component verification, 3-79
 - definition, 3-78
- Reduced ATP, 4-1
- Remote GPS distribution. *See* RGPS distribution
- Report generation, ATP report, 4-27
- Required test equipment
 - communications system analyzer, 1-6, 1-8
 - digital multimeter, 1-9
 - directional coupler, 1-9
 - Ethernet LAN transceiver, 1-7
 - GPIB cables, 1-9
 - high-impedance conductive wrist strap, 1-10
 - power meter, 1-9
 - RF adapters, 1-10
 - RF attenuator, 1-9
 - RF load, 1-10
 - RS232 to GPIB interface, 1-7
 - timing reference cables, 1-9
- Required test equipment and software, list, 1-6
- RESET Pushbutton, GLI, 6-31
- Revision History, xxv
- RF
 - attenuator, 1-9
 - Circular - optional test equipment, 1-11
 - load for required test equipment, 1-10
 - required test equipment load, 1-10
 - test cable, 1-10
- RF path, fault isolation, 6-11
- RF path calibration. *See* Bay Level Offset calibration
- RFDS - Fault Isolation, 6-25
- RFDS calibration
 - description, 3-100
 - procedure, 3-101
- RFDS Location, 1-29
- RFDS parameters, 3-93
 - checking, 3-94
 - setting, 3-94
- RFDS Test Subscriber Unit, 3-34
- RFDS TSU Calibration Channel Frequencies, 3-100
- RGPS distribution
 - description, 1-20
 - punchdowns
 - 20-pair punchblock, 3-20
 - 50-pair punchblock
 - non-expansion frame, 3-19
 - primary expansion frame, 3-20
 - secondary expansion frame, 3-19
- Rho
 - TX waveform quality acceptance test, 4-18
 - waveform quality requirements, 4-18
- ROM code
 - described, 3-33
 - downloading, G-1
 - procedure, G-2
- RS232 to GPIB interface
 - modifications required for Automated Testing, 1-7
 - required test equipment, 1-7
- RX
 - acceptance tests, FER, 4-25
 - antenna VSWR, test data sheets, A-11
 - sensitivity/frame error rate, 4-14
- RX and TX paths fail, Troubleshooting, RFDS, 6-26

RX path. *See* receive path

S

SC 4812 BTS Optimization/ATP Test Matrix, B-2

SCCP Backplane Troubleshooting, Procedure, 6-20

SCLPA, convergence test data sheets, A-7

Selecting Test Equipment, 3-68

Set Antenna Map Data, 3-98

Set RFDS Configuration Data, 3-99

Setting Cable Loss Values, 3-76

Setting Control Port, 3-15

Setting TX Coupler Loss Value, 3-77

shut-down, BTS power. *See* power, removal

SIF, output considerations vs BBX gain set point, C-1

signal generator, 1X FER acceptance test, 4-6

Site, equipage verification, 3-3

Site checklist, verification data sheets, A-2

Site documents, 1-12

site equipage, CDF file, 3-2

Site expansion, 1-4

Span line

- T1/E1 verification equipment, 1-11
- troubleshooting, 6-34

Span line configuration, troubleshooting, 6-36

Span Line connector , 6-19

SPANS LED, 6-30

Spectral purity, TX mask - primary and redundant BBX, 4-13

Spectral purity transmit mask, acceptance test, 4-16

Spectrum analyzer, optional test equipment, 1-10

STATUS LED, GLI, 6-30

Supported Test Sets, 3-51

SYNC Monitor Connector, CSM, 6-29

System Connectivity Test, F-17

T

T1, isolate BTS from the T1 spans, 3-14

Tektronics model 2445 test equipment, 1-11

Test data sheets

- Alarm verification, A-11

general optimization checklist, A-4

GPS receiver operation, A-5

initial power tests, A-3

LFR receiver operation, A-6

pre-power tests, A-3

preliminary operations, A-2

RX antenna VSWR, A-11

SCLPA convergence, A-7

site checklist, A-2

TX antenna VSWR, A-9

TX BLO, A-8

verification of test equipment used, A-1

Test equipment

See also Optional test equipment; Required test equipment

set up, TX output verification/control, 4-6

system analyzer, 1-8

TX acceptance tests, 4-6

verification data sheets, A-1

Test equipment connections , preliminary Agilent E4406A/E4432B set-up, F-22

Test Equipment Setup Calibration for RX Bay Level Offset, signal generator and spectrum analyzer, 3-74

Test Equipment Setup Calibration for TX Bay Level Offset, F-32

Test Equipment Setup Chart, 3-52

Test equipment setup RF path calibration, 3-82

Timing reference cables, required test equipment

Model SGLN1145A/4132A CSMs, 1-9

Model SGLN4132B CSMs, 1-9

transmit path

calibration, 3-78

component verification, 3-79

definition, 3-78

Transmit TX path audit, 3-90

Transmit TX path calibration, 3-83

Troubleshooting

DC Power Problems, 6-23

RF path fault isolation, 6-11

Set span configuration, 6-36

span problems, 6-34

TX and RX Signal Routing, 6-24

TX level accuracy fault isolation, 6-13

troubleshooting

communications system analyzer communication, 6-6

Ethernet LAN, 6-2

GLI IP address, 6-3

- LMF login failure, 6-2
 - power meter communication, 6-5
 - signal generator communication, 6-6
 - TSU NAM, programming
 - description, 3-96
 - parameter ranges, 3-97
 - parameters, 3-96
 - procedure, 3-102
 - TX
 - acceptance tests
 - code domain power/noise floor, 4-22
 - equipment setup, 4-6
 - pilot time offset, 4-20
 - spectral purity mask, 4-15
 - spectrum analyzer display, 4-17
 - waveform quality (rho), 4-18
 - all inclusive TX ATP test, 4-8
 - antenna VSWR, test data sheets, A-9, A-11
 - BLO test data sheets, A-8
 - level accuracy fault isolation, 6-13
 - output acceptance tests
 - code domain power noise, 4-13
 - pilot time offset, 4-13
 - waveform quality, 4-13
 - TX and RX Frequency vs Channel , D-2
 - TX and RX Signal Routing, SCCP Backplane
 - Troubleshooting, 6-24
 - TX Audit Test, 3-90
 - TX Bay Level Offset and TX ATP test equipment
 - setup calibration, signal generator and spectrum analyzer, 3-73
 - TX calibration, 3-86
 - All Cal/Audit, 3-86
 - set-up, 3-58
 - Advantest R3267, 3-60, H-18
 - Advantest R3465, 3-59
 - Agilent 8935, 3-58
 - Agilent E4406A, 3-60, H-18
 - CyberTest, 3-58
 - HP 8921A, 3-59
 - TX calibration procedure, 3-88
 - TX combiners. *See* 2:1 combiners
 - tx fine adjust, E-1
 - TX path. *See* transmit path
 - TX path calibration, 3-86
 - TX/RX OUT Connections, 4-3
- ## U
- Updating CDMA LMF Files, 5-1
 - UTP, LMF to BTS connection, 3-22
- ## V
- verification during calibration, 3-79
 - Verify
 - test equipment used, test data sheets, A-1
 - TX output, 4-6
 - Verify GLI ROM code load, 3-34
 - version Folder, 3-12
- ## W
- Waveform quality (Rho), acceptance test procedure, 4-18
- ## X
- XCVR Backplane Troubleshooting, 6-19
 - Xircom Model PE3-10B2
 - LMF to BTS connection, 3-22
 - remove from BTS, 5-4

