



# BTS Optimization/ATP

CDMA LMF

*Software Release 2.16.X*

**SC™ 4812ET**

1.9 GHz and 800 MHz CDMA

English  
Jan 2002  
68P09253A74-A

## Notice

While reasonable efforts have been made to assure the accuracy of this document, Motorola, Inc. assumes no liability resulting from any inaccuracies or omissions in this document, or from use of the information obtained herein. The information in this document has been carefully checked and is believed to be entirely reliable. However, no responsibility is assumed for inaccuracies or omissions. Motorola, Inc. reserves the right to make changes to any products described herein and reserves the right to revise this document and to make changes from time to time in content hereof with no obligation to notify any person of revisions or changes. Motorola, Inc. does not assume any liability arising out of the application or use of any product, software, or circuit described herein; neither does it convey license under its patent rights or the rights of others.

It is possible that this publication may contain references to, or information about Motorola products (machines and programs), programming, or services that are not announced in your country. Such references or information must not be construed to mean that Motorola intends to announce such Motorola products, programming, or services in your country.

## Copyrights

This instruction manual, and the Motorola products described in this instruction manual may be, include or describe copyrighted Motorola material, such as computer programs stored in semiconductor memories or other media. Laws in the United States and other countries preserve for Motorola certain exclusive rights for copyrighted material, including the exclusive right to copy, reproduce in any form, distribute and make derivative works of the copyrighted material. Accordingly, any copyrighted Motorola material contained herein or in the Motorola products described in this instruction manual may not be copied, reproduced, distributed, merged or modified in any manner without the express written permission of Motorola. Furthermore, the purchase of Motorola products shall not be deemed to grant either directly or by implication, estoppel, or otherwise, any license under the copyrights, patents or patent applications of Motorola, as arises by operation of law in the sale of a product.

## Usage and Disclosure Restrictions

### License Agreement

The software described in this document is the property of Motorola, Inc. It is furnished by express license agreement only and may be used only in accordance with the terms of such an agreement.

### Copyrighted Materials

Software and documentation are copyrighted materials. Making unauthorized copies is prohibited by law. No part of the software or documentation may be reproduced, transmitted, transcribed, stored in a retrieval system, or translated into any language or computer language, in any form or by any means, without prior written permission of Motorola, Inc.

### High Risk Activities

Components, units, or third-party products used in the product described herein are NOT fault-tolerant and are NOT designed, manufactured, or intended for use as on-line control equipment in the following hazardous environments requiring fail-safe controls: the operation of Nuclear Facilities, Aircraft Navigation or Aircraft Communication Systems, Air Traffic Control, Life Support, or Weapons Systems ("High Risk Activities"). Motorola and its supplier(s) specifically disclaim any expressed or implied warranty of fitness for such High Risk Activities.

## Trademarks



and Motorola are registered trademarks of Motorola, Inc.

Product and service names profiled herein are trademarks of Motorola, Inc. Other manufacturers' products or services profiled herein may be referred to by trademarks of their respective companies.

## Copyright

© Copyright 2002 Motorola, Inc.  
All Rights Reserved



Printed on  
Recyclable Paper

REV010598

*SPECIFICATIONS SUBJECT TO CHANGE WITHOUT NOTICE*



## Table of Contents

### SC™ 4812ET BTS Optimization/ATP — CDMA LMF

---

CDMA 1.9 GHz and 800 MHz

List of Figures .....	v
List of Tables .....	ix
Product Information .....	xiv
FCC Part 15 .....	xv
FCC Part 68 .....	xvii
Foreword .....	xviii
General Safety .....	xxi
Revision History .....	xxiii
Patent Notification .....	xxiv

#### Chapter 1: Introduction

Optimization Overview .....	1-1
BTS Equipment Identification .....	1-13

#### Chapter 2: Preliminary Operations

Preliminary Operations: Overview .....	2-1
Initial Power Up .....	2-3

#### Chapter 3: Optimization/Calibration

Optimization/Calibration – Introduction .....	3-1
Isolate Span Lines/Connect LMF .....	3-4
Preparing the LMF .....	3-14
Using CDMA LMF .....	3-31
Download the BTS .....	3-38
CSM System Time – GPS & LFR/HSO Verification .....	3-45
Test Equipment Set-up .....	3-55
Test Set Calibration .....	3-73
Bay Level Offset Calibration .....	3-83
RFDS Setup and Calibration .....	3-98
Alarms Testing .....	3-108

---

## Table of Contents – continued

### Chapter 4: Automated Acceptance Test Procedure (ATP)

Automated Acceptance Test Procedures – Overview .....	4-1
TX Spectral Purity Transmit Mask Acceptance Test .....	4-7
TX Waveform Quality (rho) Acceptance Test .....	4-9
TX Pilot Time Offset Acceptance Test .....	4-10
TX Code Domain Power Acceptance Test .....	4-11
RX Frame Error Rate (FER) Acceptance Test .....	4-13
Generate an ATP Report .....	4-14

### Chapter 5: Leaving the Site

Prepare to Leave the Site .....	5-1
---------------------------------	-----

### Chapter 6: Basic Troubleshooting

Basic Troubleshooting Overview .....	6-1
Troubleshooting: Installation .....	6-2
Troubleshooting: Download .....	6-4
Troubleshooting: Calibration .....	6-6
Troubleshooting: Transmit ATP .....	6-8
Troubleshooting: Receive ATP .....	6-10
Troubleshooting: CSM Checklist .....	6-11
C-CCP Backplane Troubleshooting .....	6-13
RFDS – Fault Isolation .....	6-20
Module Front Panel LED Indicators and Connectors .....	6-22
Basic Troubleshooting – Span Control Link .....	6-29

### Appendix A: Data Sheets

Appendix A: Optimization (Pre-ATP) Data Sheets .....	A-1
Appendix A: Site Serial Number Check List .....	A-17

### Appendix B: FRU Optimization/ATP Test Matrix

FRU Optimization/ATP Test Matrix .....	B-1
--	-----

### Appendix C: BBX Gain Set Point vs. BTS Output Considerations

Appendix C: BBX Gain Set Point vs. BTS Output Considerations .....	C-1
--	-----

### Appendix D: CDMA Operating Frequency Information

CDMA Operating Frequency Programming Information – North American PCS Bands . D-1	
--	--

### Appendix E: PN Offset/I & Q Offset Register Programming Information

Appendix E: PN Offset Programming Information .....	E-1
---	-----

---

## Table of Contents – continued

### Appendix F: Test Equipment Preparation

Test Equipment Preparation .....	F-1
Manual Cable Calibration .....	F-11

### Appendix G: In-Service Calibration

Introduction .....	G-1
Power Delta Calibration .....	G-2
In-Service Calibration .....	G-12

### Appendix H: RF Cabinet Interconnect Cables

RF Cabinet Interconnect Cables .....	H-1
--------------------------------------	-----

### Appendix I: GPIB Addresses

GPIB Addresses .....	I-1
CDMA 2000 Test Equipment Preparation .....	I-10

### Appendix J: Download ROM Code

Downloading ROM Code with the LMF .....	J-1
---	-----

### Appendix K: Optimizing Companion Frame

Optimizing Companion Frame .....	K-1
----------------------------------	-----

Index .....	Index-1
-------------	---------



## List of Figures

### SC™ 4812ET BTS Optimization/ATP — CDMA LMF

CDMA 1.9 GHz and 800 MHz

Figure 1-1: Null Modem Cable Detail	1-8
Figure 1-2: SC 4812ET RF Cabinet	1-14
Figure 1-3: RF Cabinet Internal FRUs	1-15
Figure 1-4: SC 4812ET C-CCP Shelf	1-17
Figure 1-5: SC 4812ET Intercabinet I/O Detail (Rear View)	1-18
Figure 1-6: SC 4812ET I/O Plate Diagram	1-19
Figure 1-7: RFDS Location in an SC 4812ET RF Cabinet	1-20
Figure 1-8: SC4812ET LPA Configuration with Combiners/Filters	1-23
Figure 1-9: Power Cabinet	1-24
Figure 1-10: Power Cabinet with Batteries Installed (Doors Removed for Clarity)	1-25
Figure 2-1: Backplane DIP Switch Settings	2-2
Figure 2-2: AC Load Center Wiring	2-5
Figure 2-3: Meter Alarm Panel	2-6
Figure 2-4: Temperature Compensation Panel	2-6
Figure 2-5: RF Cabinet Circuit Breaker Panel and 27Vdc Terminal Locations	2-9
Figure 2-6: Heat Exchanger Blower Assembly	2-12
Figure 2-7: Power Cabinet Circuit Breaker Assemblies	2-13
Figure 2-8: Power Cabinet AC Circuit Breakers	2-14
Figure 2-9: Power Cabinet DC Circuit Breakers	2-15
Figure 3-1: Back and Front View of the CSU	3-5
Figure 3-2: 50 Pair Punch Block	3-7
Figure 3-3: LMF Folder Structure	3-20
Figure 3-4: LMF Connection Detail	3-22
Figure 3-5: BTS Ethernet LAN Interconnect Diagram	3-23
Figure 3-6: BTS Login Window	3-25
Figure 3-7: CDMA LMF Computer Common MMI Connections	3-37
Figure 3-8: CSM MMI Terminal Connection	3-48
Figure 3-9: Cable Calibration Test Setup – CyberTest, Agilent 8935, Advantest R3465, and HP 8921A	3-60

... continued on next page

## List of Figures – continued

Figure 3-10: Cable Calibration Test Setup – Agilent E4406A/E4432B and Advantest R3267/R3562 .....	3-61
Figure 3-11: TX Calibration Test Setup – CyberTest (IS–95A/B) and Agilent 8935 (IS–95A/B and CDMA2000 1X) .....	3-62
Figure 3-12: TX Calibration Test Setup – Using Power Meter .....	3-63
Figure 3-13: TX Calibration Test Setup – Agilent E4406A and Advantest R3567 (IS–95A/B and CDMA2000 1X) .....	3-64
Figure 3-14: IS–95A/B Optimization/ATP Test Set–up, TRDC Shown – CyberTest and Advantest R3465 .....	3-65
Figure 3-15: IS–95A/B Optimization/ATP Test Setup – HP 8921A .....	3-66
Figure 3-16: IS–95A/B and CDMA2000 1X Optimization/ATP Test Setup With DRDCs – Agilent Test Equipment .....	3-67
Figure 3-17: IS–95A/B and CDMA2000 1X Optimization/ATP Test Setup With DRDCs – Advantest R3267/3562 Test Equipment .....	3-68
Figure 3-18: IS–95A/B and CDMA2000 1X Optimization/ATP Test Setup With TRDCs – Agilent Test Equipment .....	3-69
Figure 3-19: IS–95A/B and CDMA2000 1X Optimization/ATP Test Setup With TRDCs – Advantest R3267/3562 Test Equipment .....	3-70
Figure 3-20: Typical TX ATP Setup with Directional Coupler (shown with and without RFDS) .....	3-71
Figure 3-21: Typical RX ATP Setup with Directional Coupler (shown with or without RFDS) .....	3-72
Figure 3-22: Calibrating Test Equipment Setup for TX Cable Calibration(Using Signal Generator and Spectrum Analyzer) .....	3-79
Figure 3-23: Calibrating Test Equipment Setup for RX ATP Test (Using Signal Generator and Spectrum Analyzer) .....	3-80
Figure 3-24: Battery Overtemperature Sensor .....	3-113
Figure 3-25: Location of Connector J8 on the Meter Alarm Panel .....	3-115
Figure 4-1: TX Mask Verification Spectrum Analyzer Display .....	4-8
Figure 4-2: Code Domain Power and Noise Floor Levels .....	4-12
Figure 5-1: MGLI2/SGLI2 MMI Port Connection .....	5-4
Figure 6-1: CSM Front Panel Indicators & Monitor Ports .....	6-23
Figure 6-2: GLI2 Front Panel Operating Indicators .....	6-26
Figure 6-3: MCC24/8E Front Panel LEDs and LED Indicators .....	6-28
Figure D-1: North America PCS Frequency Spectrum (CDMA Allocation) .....	D-1
Figure D-2: North American Cellular Telephone System Frequency Spectrum (CDMA Allocation). .....	D-4
Figure F-1: HP8921A/600 Cables Connection for 10 MHz Signal and GPIB without Rubidium .....	F-2
Figure F-2: HP8921A Cables Connection for 10 MHz Signal and GPIB with Rubidium .....	F-4
Figure F-3: Cable Connections for Test Set without 10 MHz Rubidium Standard .....	F-7

... continued on next page

**List of Figures** – continued

Figure F-4: Cable Connections for Test Set with 10 MHz Rubidium Standard .	F-8
Figure F-5: Agilent 10 MHz Reference Connections . . . . .	F-10
Figure F-6: Cable Calibration Using HP8921 with PCS Interface . . . . .	F-14
Figure F-7: Cable Calibration using Advantest R3465 . . . . .	F-17
Figure F-8: Power Meter Detail . . . . .	F-18
Figure F-9: Gigatronix 8541C Power Meter Detail . . . . .	F-21
Figure G-1: Delta Calibration Setup – HP8921A to HP437B . . . . .	G-4
Figure G-2: Delta Calibration Setup – HP8921A to HP8921A . . . . .	G-4
Figure G-3: Delta Calibration Setup – R3561L to HP437B . . . . .	G-6
Figure G-4: Delta Calibration Setup – R3561L to R3465 . . . . .	G-7
Figure G-5: Delta Calibration Setup – HP8935 to HP437B . . . . .	G-8
Figure G-6: Delta Calibration Setup – HP8935 to HP8935 . . . . .	G-9
Figure G-7: Delta Calibration Setup – Agilent E4432B to HP437 . . . . .	G-11
Figure G-8: Delta Calibration Setup – Agilent E4432B to Agilent E4406A . . .	G-11
Figure G-9: Optimization/ATP Test Setup Using RFDS . . . . .	G-13
Figure G-10: IS-95 A/B/C Optimization/ATP Test Setup Using RFDS . . . . .	G-14
Figure H-1: 4812ET RF Cabinet Internal FRU Locations . . . . .	H-3
Figure H-2: C-CCP Shelf Cable Numbers and Connectors . . . . .	H-5
Figure H-3: C-CCP Backplane . . . . .	H-6
Figure H-4: LPAs for the SC 4812ET . . . . .	H-7
Figure H-5: BTS Combiner to LPA Backplane Cables . . . . .	H-8
Figure H-6: Combiner to LPA Backplane/LPA Backplane To CIO Board Cables . . . . .	H-9
Figure H-7: Components Located on CIO Card . . . . .	H-10
Figure H-8: LPAC Interface Board Connectors and Attaching Cable Numbers . . . . .	H-11
Figure H-9: ETIB I/O Connectors and Attaching Cable Numbers . . . . .	H-12
Figure H-10: SPAN I/O Cables and Connectors . . . . .	H-14
Figure H-11: 3 Sector, 2 Carrier BTS Combiner DRDC/TRDC Cable Connection . . . . .	H-16
Figure H-12: BTS 2 to 1, 3 or 6 Sector Combiner DRDC/TRDC Cable Connection . . . . .	H-17
Figure H-13: BTS Combiner DRDC/TRDC Cable Connection . . . . .	H-18
Figure H-14: SC 4812ET BTS Combiner DRDC/TRDC Cable Connection . .	H-19
Figure H-15: DRDC To C-CCP Cage MPC Boards Cable Connections . . . . .	H-21
Figure H-16: RFDS Cable Connectors . . . . .	H-22
Figure H-17: SC 4812ET BTS Combiner DRDC/TRDC RFDS Cable Connection . . . . .	H-24
Figure H-18: 50 Pair Punchblock . . . . .	H-26

. . . continued on next page



---

## List of Figures – continued

Figure H-19: SC 4812ET RF Cabinet Parts Locator .....	H-32
Figure I-1: HP437 Power Meter .....	I-1
Figure I-2: Gigatronix 8541C Power Meter Detail .....	I-2
Figure I-3: HP8935 Test Set .....	I-5
Figure I-4: HP8921A and HP83236A/B .....	I-7
Figure I-5: R3465 Communications Test Set .....	I-8
Figure I-6: RS232 GPIB Interface Box .....	I-9
Figure I-7: Setting Advantest R3267 GPIB Address .....	I-11
Figure I-8: Advantest R3562 GPIB Address Switch Setting .....	I-11
Figure I-9: Setting Agilent E4406A GPIB Address .....	I-13
Figure I-10: Setting Agilent E4432B GPIB Address .....	I-15
Figure K-1: Cabling of SC 4812ET Companion BTS to SC 4812ET Companion BTS (3 Sector) .....	K-1
Figure K-2: WinLMF Display Screen .....	K-3



## List of Tables

### SC™ 4812ET BTS Optimization/ATP — CDMA LMF

CDMA 1.9 GHz and 800 MHz

Table 1-1: CDMA LMF Test Equipment Support Table .....	1-4
Table 1-2: Abbreviations and Acronyms .....	1-11
Table 1-3: C-CCP Shelf/Cage Card/Module Device ID Numbers (Top Shelf) .....	1-13
Table 1-4: C-CCP Shelf/Cage Card/Module Device ID Numbers (Bottom Shelf) .....	1-13
Table 1-5: BTS Sector Configuration .....	1-21
Table 1-6: Sector Configurations .....	1-22
Table 2-1: Initial Installation of Boards/Modules .....	2-1
Table 2-2: Initial Inspection and Setup .....	2-3
Table 2-3: AC Voltage Measurements .....	2-4
Table 2-4: Applying AC Power .....	2-5
Table 2-5: Power Cabinet Power Up Tests .....	2-6
Table 2-6: DC Power Pre-test (BTS Frame) .....	2-7
Table 2-7: RF Cabinet Power Up .....	2-8
Table 2-8: Battery Charge Test (Connected Batteries) .....	2-10
Table 2-9: Battery Discharge Test .....	2-11
Table 2-10: Heat Exchanger Power Up .....	2-11
Table 3-1: Pin-Out for 50-Pair Punchblock .....	3-8
Table 3-2: T1/E1 Span Isolation .....	3-13
Table 3-3: LMF Operating System Installation .....	3-14
Table 3-4: Copying CBSC CDF Files to the LMF .....	3-16
Table 3-5: Creating a Named Hyperlink Connection for MMI Connection . . . .	3-18
Table 3-6: LMF to BTS Connection .....	3-21
Table 3-7: Pinging the Processors .....	3-24
Table 3-8: Logging into the BTSLMF PC .....	3-24
Table 3-9: Downloading Site Specific BTS Files .....	3-25
Table 3-10: Downloading and linking master-bts-cdma directory files for device loads .....	3-26
Table 3-11: Create BTS Specific CDF File .....	3-28

---

## List of Tables – continued

Table 3-12: Update BTS Specific CDF File Device Load Version .....	3-29
Table 3-13: Update Antenna Mapping Files .....	3-30
Table 3-14: BTS GUI Login Procedure .....	3-33
Table 3-15: BTS CLI Login Procedure .....	3-35
Table 3-16: BTS GUI Logout Procedure .....	3-35
Table 3-17: BTS CLI Logout Procedure .....	3-36
Table 3-18: Establishing MMI Communications .....	3-37
Table 3-19: Verify GLI ROM Code Loads .....	3-39
Table 3-20: Download and Enable MGLI and GLI Devices .....	3-40
Table 3-21: Download RAM Code and Data to Non-GLI Devices .....	3-41
Table 3-22: Select CSM Clock Source .....	3-42
Table 3-23: Enable CSMs .....	3-43
Table 3-24: Enable MCCs .....	3-44
Table 3-25: Test Equipment Setup (GPS & LFR/HSO Verification) .....	3-47
Table 3-26: GPS Initialization/Verification .....	3-49
Table 3-27: LORAN-C Initialization/Verification .....	3-53
Table 3-28: IS-95A/B-only Test Equipment Interconnection .....	3-57
Table 3-29: CDMA2000 1X/IS-95A/B Test Equipment Interconnection .....	3-58
Table 3-30: Selecting Test Equipment Manually in a Serial Connection Tab .....	3-74
Table 3-31: Selecting Test Equipment Using Auto-Detect .....	3-76
Table 3-32: Test Equipment Calibration .....	3-77
Table 3-33: Cable Calibration .....	3-78
Table 3-34: Calibrating TX Cables Using Signal Generator and Spectrum Analyzer .....	3-79
Table 3-35: Calibrating RX Cables Using a Signal Generator and Spectrum Analyzer .....	3-80
Table 3-36: Setting Cable Loss Values .....	3-81
Table 3-37: Setting Coupler Loss Values .....	3-82
Table 3-38: BLO BTS.cal file Array Branch Assignments .....	3-85
Table 3-39: BTS.cal File Array (Per Sector) .....	3-86
Table 3-40: Test Equipment Setup (RF Path Calibration) .....	3-87
Table 3-41: BTS TX Path Calibration .....	3-90
Table 3-42: Download BLO .....	3-91
Table 3-43: BTS TX Path Audit .....	3-94
Table 3-44: All Cal/Audit Test .....	3-96
Table 3-45: Create CAL File .....	3-97
Table 3-46: RFDS Parameter Settings .....	3-99

---

## List of Tables – continued

Table 3-47: Definition of Parameters .....	3-101
Table 3-48: Valid NAM Field Ranges .....	3-102
Table 3-49: Set Antenna Map Data .....	3-103
Table 3-50: Set RFDS Configuration Data .....	3-104
Table 3-51: RFDS TSIC Calibration Channel Frequencies .....	3-105
Table 3-52: RFDS Calibration .....	3-106
Table 3-53: Program NAM Procedure .....	3-107
Table 3-54: Heat Exchanger Alarm .....	3-109
Table 3-55: Door Alarm .....	3-109
Table 3-56: AC Fail Alarm .....	3-109
Table 3-57: Minor Alarm .....	3-110
Table 3-58: Single Rectifier Fail or Minor Alarm .....	3-110
Table 3-59: Multiple Rectifier Failure or Major Alarm .....	3-111
Table 3-60: Single Rectifier Fail or Minor Alarm .....	3-111
Table 3-61: Multiple Rectifier Failure or Major Alarm .....	3-112
Table 3-62: Battery Over Temperature Alarm .....	3-112
Table 3-63: Rectifier Over Temperature Alarm .....	3-114
Table 3-64: Check Before Leaving the Site .....	3-115
Table 4-1: ATP Test Procedure .....	4-6
Table 4-2: Generate an ATP Report .....	4-14
Table 5-1: External Test Equipment Removal .....	5-1
Table 5-2: Copy Files from LMF to a Diskette .....	5-1
Table 5-3: Copy CAL Files From Diskette to the CBSC .....	5-2
Table 5-4: BTS Span Parameter Configuration .....	5-3
Table 5-5: Set BTS Span Parameter Configuration .....	5-4
Table 5-6: T1/E1 Span/IFM Connections .....	5-6
Table 5-7: Terminate the LMF Session and Remove the LMF .....	5-6
Table 6-1: Login Failure Troubleshooting Procedure .....	6-2
Table 6-2: Troubleshooting a Power Meter Communication Failure .....	6-2
Table 6-3: Troubleshooting a Communications Analyzer Communication Failure .....	6-3
Table 6-4: Troubleshooting Code Download Failure .....	6-4
Table 6-5: Troubleshooting Data Download Failure .....	6-4
Table 6-6: Troubleshooting Device Enable (INS) Failure .....	6-5
Table 6-7: LPA Errors .....	6-5
Table 6-8: Troubleshooting BLO Calibration Failure .....	6-6
Table 6-9: Troubleshooting Calibration Audit Failure .....	6-7

**List of Tables** – continued

Table 6-10: Troubleshooting Forward Link Failure (BTS Passed Reduced ATP) .....	6-8
Table 6-11: Troubleshooting TX Mask Measurement Failure .....	6-8
Table 6-12: Troubleshooting Rho and Pilot Time Offset Measurement Failure .....	6-8
Table 6-13: Troubleshooting Code Domain Power and Noise Floor Measurement Failure .....	6-9
Table 6-14: Troubleshooting Carrier Measurement Failure .....	6-9
Table 6-15: Troubleshooting Multi-FER Failure .....	6-10
Table 6-16: No GLI2 Control via LMF (all GLI2s) .....	6-15
Table 6-17: No GLI2 Control through Span Line Connection (Both GLI2s) ..	6-15
Table 6-18: MGLI2 Control Good – No Control over Co-located GLI2 .....	6-15
Table 6-19: MGLI2 Control Good – No Control over AMR .....	6-16
Table 6-20: MGLI2 Control Good – No Control over Co-located GLI2s .....	6-16
Table 6-21: BBX Control Good – No (or Missing) Span Line Traffic .....	6-16
Table 6-22: No MCC-1X/MCC24E/MCC8E Channel Elements .....	6-17
Table 6-23: No DC Input Voltage to Power Supply Module .....	6-18
Table 6-24: No DC Input Voltage to any C-CCP Shelf Module .....	6-19
Table 6-25: No DC Input Voltage to any C-CCP Shelf Module .....	6-19
Table 6-26: RFDS Fault Isolation – All tests fail .....	6-20
Table 6-27: RFDS Fault Isolation – All RX and TX paths fail .....	6-20
Table 6-28: RFDS Fault Isolation – All tests fail on single antenna path .....	6-21
Table 6-29: Troubleshooting Control Link Failure .....	6-29
Table A-1: Verification of Test Equipment Used .....	A-1
Table A-2: Site Checklist .....	A-2
Table A-3: Preliminary Operations .....	A-2
Table A-4: GPS Receiver Operation .....	A-5
Table A-5: LFR Receiver Operation .....	A-6
Table A-6: LPA IM Reduction .....	A-7
Table A-7: TX BLO Calibration (3-Sector: 1-Carrier, 2-Carrier and 4-Carrier Non-adjacent Channels) .....	A-8
Table A-8: TX Bay Level Offset Calibration (3-Sector: 2-Carrier Adjacent Channels) .....	A-10
Table A-9: TX Bay Level Offset Calibration (3-Sector: 3 or 4-Carrier Adjacent Channels) .....	A-11
Table A-10: TX BLO Calibration (6-Sector: 1-Carrier, 2-Carrier Non-adjacent Channels) .....	A-13
Table A-11: TX Antenna VSWR .....	A-15
Table A-12: RX Antenna VSWR .....	A-16

---

## List of Tables – continued

Table A-13: CDI Alarm Input Verification .....	A-16
Table B-1: SC 4812ET BTS Optimization and ATP Test Matrix .....	B-2
Table C-1: BBX Gain Set Point vs. Actual BTS Output (in dBm) .....	C-1
Table D-1: 1900 MHz TX and RX Frequency vs. Channel .....	D-2
Table D-2: 800 MHz TX and RX Frequency vs. Channel .....	D-4
Table E-1: PnMaskI and PnMaskQ Values for PilotPn .....	E-3
Table F-1: HP8921A/600 Communications Test Set Rear Panel Connections Without Rubidium .....	F-1
Table F-2: HP8921A/600 Communications Test Set Rear Panel Connections With Rubidium .....	F-3
Table F-3: System Connectivity .....	F-5
Table F-4: Setting HP8921A GPIB Address .....	F-6
Table F-5: Pretest Setup for HP8921A .....	F-6
Table F-6: Pretest Setup for HP8935 .....	F-6
Table F-7: Advantest R3465 GPIB Address and Clock Setup .....	F-9
Table F-8: Pretest Setup for Advantest R3465 .....	F-9
Table F-9: Calibrating Test Cable Setup (using the HP PCS Interface) .....	F-11
Table F-10: Procedure for Calibrating Test Cable Setup Using Advantest R3465 .....	F-15
Table F-11: Power Meter Calibration Procedure .....	F-18
Table F-12: Calibrate Gigatronics 8541C Power Meter .....	F-20
Table G-1: HP8921A Power Delta Calibration Procedure .....	G-2
Table G-2: Advantest Power Delta Calibration Procedure .....	G-4
Table G-3: HP8935 Power Delta Calibration Procedure .....	G-7
Table G-4: Agilent E4406A Power Delta Calibration Procedure .....	G-9
Table G-5: In–Service Calibration .....	G-15
Table H-1 : 4812ET RF CABINET INTER–CONNECT CABLES .....	H-1
Table H-2: SC 4812ET Series 3-Sector Duplexed Directional Coupler to RFDS Cabling Table .....	H-22
Table H-3: SC 4812ET Series 6-Sector Duplexed Directional Coupler to RFDS Cabling Table .....	H-23
Table H-4: Pin–Out for 50–Pair Punchblock .....	H-27
Table I-1: Verify and/or Change HP437 Power Meter GPIB Address .....	I-1
Table I-2: Verify and/or Change Gigatronics 8541C Power Meter GPIB Address .....	I-2
Table I-3: Verify and/or Change Motorola CyberTest GPIB Address .....	I-3
Table I-4: Verify and/or Change HP8935 GPIB Address .....	I-4
Table I-5: Verify and/or Change HP8921A and HP83236A GPIB Addresses .....	I-6

---

**List of Tables** – continued

Table I-6: Verify and/or Change Advantest R3465 GPIB Address .....	I-8
Table I-7: Verify and Change Advantest R3267 GPIB Address .....	I-10
Table I-8: Verify and Change Agilent E4406A GPIB Address .....	I-12
Table I-9: Verify and Change Agilent E4432B GPIB Address .....	I-14
Table J-1: Download ROM and RAM Code to Devices .....	J-2
Table K-1: Optimizing the TX section of the Companion Frame .....	K-1
Table K-2: Optimizing the RX (Main) section of the Companion Frame .....	K-2
Table K-3: Optimizing the RX (Diversity) on a Single Frame .....	K-2
Table K-4: Optimizing the RX (Diversity) on a Two Frame Companion Site .....	K-2

---

## Product Information

### Model & Options Charts

Refer to the *SC 4812ET Field Replaceable Units* manual for detailed model structure and option information

This document covers only the steps required to verify the functionality of the Base Transceiver Subsystem (BTS) equipment prior to system level testing, and is intended to supplement site specific application instructions. It also should be used in conjunction with existing product manuals. Additional steps may be required.



---

## FCC Part 15

### FCC Part 15 Requirements

This section conveys FCC Part 15 requirements for the T/ET/ETL series BTS cabinets.

#### Part 15.19a(3) – INFORMATION TO USER

##### NOTE

This device complies with Part 15 of the FCC Rules. Operation is subject to the following two conditions:  
(1) this device may not cause harmful interference, and  
(2) this device must accept any interference received, including interference that may cause undesired operation.

#### Part 15.21 – INFORMATION TO USER



##### CAUTION

Changes or modifications not expressly approved by Motorola could void your authority to operate the equipment.

**15.105(b) – INFORMATION TO USER**

**NOTE**

This equipment has been tested and found to comply with the limits for a Class B digital device, pursuant to Part 15 of the FCC Rules. These limits are designed to provide reasonable protection against harmful interference in a residential installation. This equipment generates, uses and can radiate radio frequency energy and, if not installed and used in accordance with the instructions, may cause harmful interference to radio communications. However, there is no guarantee that interference will not occur in a particular installation. If this equipment does cause harmful interference to radio or television reception, which can be determined by turning the equipment OFF and ON, the user is encouraged to try to correct the interference by one or more of the following measures:

- Reorient or relocate the receiving antenna.
- Increase the separation between the equipment and receiver.
- Connect the equipment into an outlet on a circuit different from that to which the receiver is connected.
- Consult the dealer or an experienced radio/TV technician for help.

---

## FCC Part 68

### FCC Part 68 Requirements

This equipment complies with Part 68 of the Federal Communications Commission (FCC) Rules and regulations. A label inside the cabinet frame easily visible with the door open in the upper portion of the cabinet contains, among other information, the FCC Registration Number and Ringer Equivalence Number (REN) for this equipment. If requested, this information must be provided to the telephone company.

The REN is useful to determine the quantity of the devices which may connect to the telephone line. Excessive RENs on the telephone line may result in the devices not ringing in response to incoming calls. In most, but not all areas, the sum of the RENs should not exceed five (5.0). To be certain of the number of devices that may be connected to the line as determined by the total RENs, contact the telephone company to determine the maximum REN for the calling area.

If the dial-in site access modem causes harm to the telephone network, the telephone company will notify you in advance that temporary discontinuance of service may be required. If advance notice is not practical, the telephone company will notify you of the discontinuance as soon as possible. Also, you will be advised of your right to file a complaint with the FCC if you believe it is necessary.

The telephone company may make changes in its facilities, equipment, operations, or procedures that could affect the operation of your dial-in site access modem. If this happens, the telephone company will provide advance notice so that you can modify your equipment as required to maintain uninterrupted service.

If you experience trouble with the dial-in site access modem, please contact:

Motorola Cellular Service Center (MCSC)  
1501 W. Shure Drive  
Arlington Heights, Illinois 60004  
Phone Number: (847) 632-5390

for repair and/or warranty information. If the trouble is causing harm to the telephone network, the telephone company may request you to disconnect the equipment from the network until the problem is solved. You should not attempt to repair this equipment yourself. This equipment contains no customer or user-serviceable parts.

Changes or modifications not expressly approved by Motorola could void your authority to operate this equipment.

---

## Foreword

### Scope of manual

This manual is intended for use by cellular telephone system craftspersons in the day-to-day operation of Motorola cellular system equipment and ancillary devices. It is assumed that the user of this information has a general understanding of telephony, as used in the operation of the Public Switched Telephone Network (PSTN), and is familiar with these concepts as they are applied in the cellular mobile/portable radiotelephone environment. The user, however, is not expected to have any detailed technical knowledge of the internal operation of the equipment.

This manual is not intended to replace the system and equipment training offered by Motorola, although it can be used to supplement or enhance the knowledge gained through such training.

### Text conventions

The following special paragraphs are used in this manual to point out information that must be read. This information may be set-off from the surrounding text, but is always preceded by a bold title in capital letters. The four categories of these special paragraphs are:

#### **NOTE**

Presents additional, helpful, non-critical information that you can use.



#### **IMPORTANT**

Presents information to help you avoid an undesirable situation or provides additional information to help you understand a topic or concept.



#### **CAUTION**

Presents information to identify a situation in which equipment damage could occur, thus avoiding damage to equipment.



#### **WARNING**

Presents information to warn you of a potentially hazardous situation in which there is a possibility of personal injury.

. . . continued on next page

The following typographical conventions are used for the presentation of software information: In text, typewriter style characters represent prompts and the system output as displayed on a Hyperterminal screen.

## **Changes to manual**

Changes that occur after the printing date are incorporated into your manual by Cellular Manual Revisions (CMRs). The information in this manual is updated, as required, by a CMR when new options and procedures become available for general use or when engineering changes occur. The cover sheet(s) that accompany each CMR should be retained for future reference. Refer to the Revision History page for a list of all applicable CMRs contained in this manual.

## **Receiving updates**

Technical Education & Documentation (TED) maintains a customer database that reflects the type and number of manuals ordered or shipped since the original delivery of your *Motorola* equipment. Also identified in this database is a “key” individual (such as Documentation Coordinator or Facility Librarian) designated to receive manual updates from TED as they are released.

To ensure that your facility receives updates to your manuals, it is important that the information in our database is correct and up-to-date. Therefore, if you have corrections or wish to make changes to the information in our database (i.e., to assign a new “key” individual), please contact Technical Education & Documentation at:

MOTOROLA, INC.  
Technical Education & Documentation  
1 Nelson C. White Parkway  
Mundelein, Illinois 60060  
U.S.A.

Phone:  
Within U.S.A. and Canada . . . . . 800-872-8225  
Outside of U.S.A. and Canada . . . +1-847-435-5700  
FAX: . . . . . +1-847-435-5541

## **Reporting manual errors**

In the event that you locate an error or identify a deficiency in your manual, please take time to write to us at the address above. Be sure to include your name and address, the complete manual title and part number (located on the manual spine, cover, or title page), the page number (found at the bottom of each page) where the error is located, and any comments you may have regarding what you have found. We appreciate any comments from the users of our manuals.

**24-hour support service**

If you have any questions or concerns regarding the operation of your equipment, please contact the Customer Network Resolution Center for immediate assistance. The 24 hour telephone numbers are:

Arlington Heights, IL . . . . . 800-433-5202  
Arlington Heights, International . . +1-847-632-5390  
Cork, Ireland . . . . . 44-1793-565444  
Swindon, England . . . . . 44-1793-565444

**Material Available from  
Motorola Infrastructure Group  
Worldwide Cellular Services**

Material available from Motorola Infrastructure Group Worldwide Cellular Services, identified by a Motorola part number can be ordered from your sales account manager or by calling (800) 453-7988.

---

## General Safety

### Remember! . . . Safety depends on you!!

The following general safety precautions must be observed during all phases of operation, service, and repair of the equipment described in this manual. Failure to comply with these precautions or with specific warnings elsewhere in this manual violates safety standards of design, manufacture, and intended use of the equipment. Motorola, Inc. assumes no liability for the customer's failure to comply with these requirements. The safety precautions listed below represent warnings of certain dangers of which we are aware. You, as the user of this product, should follow these warnings and all other safety precautions necessary for the safe operation of the equipment in your operating environment.

### Ground the instrument

To minimize shock hazard, the equipment chassis and enclosure must be connected to an electrical ground. If the equipment is supplied with a three-conductor ac power cable, the power cable must be either plugged into an approved three-contact electrical outlet or used with a three-contact to two-contact adapter. The three-contact to two-contact adapter must have the grounding wire (green) firmly connected to an electrical ground (safety ground) at the power outlet. The power jack and mating plug of the power cable must meet International Electrotechnical Commission (IEC) safety standards.

### Do not operate in an explosive atmosphere

Do not operate the equipment in the presence of flammable gases or fumes. Operation of any electrical equipment in such an environment constitutes a definite safety hazard.

### Keep away from live circuits

Operating personnel must:

- not remove equipment covers. Only Factory Authorized Service Personnel or other qualified maintenance personnel may remove equipment covers for internal subassembly, or component replacement, or any internal adjustment.
- not replace components with power cable connected. Under certain conditions, dangerous voltages may exist even with the power cable removed.
- always disconnect power and discharge circuits before touching them.

### Do not service or adjust alone

Do not attempt internal service or adjustment, unless another person, capable of rendering first aid and resuscitation, is present.

---

## General Safety – continued

### Do not substitute parts or modify equipment

Because of the danger of introducing additional hazards, do not install substitute parts or perform any unauthorized modification of equipment. Contact Motorola Warranty and Repair for service and repair to ensure that safety features are maintained.

### Dangerous procedure warnings

Warnings, such as the example below, precede potentially dangerous procedures throughout this manual. Instructions contained in the warnings must be followed. You should also employ all other safety precautions that you deem necessary for the operation of the equipment in your operating environment.



#### **WARNING**

Dangerous voltages, capable of causing death, are present in this equipment. Use extreme caution when handling, testing, and adjusting.



---

## Revision History

### Manual Number

68P09253A74–A

### Manual Title

SC™ 4812ET BTS Optimization/ATP — CDMA LMF  
CDMA 1.9 GHz and 800 MHz

### Version Information

The following table lists the manual version, date of version, and remarks on the version.

<b>Version Level</b>	<b>Date of Issue</b>	<b>Remarks</b>
1	March 2001	Preliminary version
2	May 2001	Draft version
3	July 2001	Documentation verification and validation version
4	August 2001	First Office Application (FOA) version
5	Nov 2001	Added CDMA 2000 Equipment Set up Table; Appendix I
6	Jan 2002	Added Appendix J: Download ROM Code
7	Jan 2002	Added Companion Frame Optimization/ATP
A	Jan 2002	Released GA

---

## Patent Notification

### Patent numbers

This product is manufactured and/or operated under one or more of the following patents and other patents pending:

4128740	4661790	4860281	5036515	5119508	5204876	5247544	5301353
4193036	4667172	4866710	5036531	5121414	5204977	5251233	5301365
4237534	4672657	4870686	5038399	5123014	5207491	5255292	5303240
4268722	4694484	4872204	5040127	5127040	5210771	5257398	5303289
4282493	4696027	4873683	5041699	5127100	5212815	5259021	5303407
4301531	4704734	4876740	5047762	5128959	5212826	5261119	5305468
4302845	4709344	4881082	5048116	5130663	5214675	5263047	5307022
4312074	4710724	4885553	5055800	5133010	5214774	5263052	5307512
4350958	4726050	4887050	5055802	5140286	5216692	5263055	5309443
4354248	4729531	4887265	5058136	5142551	5218630	5265122	5309503
4367443	4737978	4893327	5060227	5142696	5220936	5268933	5311143
4369516	4742514	4896361	5060265	5144644	5222078	5271042	5311176
4369520	4751725	4910470	5065408	5146609	5222123	5274844	5311571
4369522	4754450	4914696	5067139	5146610	5222141	5274845	5313489
4375622	4764737	4918732	5068625	5152007	5222251	5276685	5319712
4485486	4764849	4941203	5070310	5155448	5224121	5276707	5321705
4491972	4775998	4945570	5073909	5157693	5224122	5276906	5321737
4517561	4775999	4956854	5073971	5159283	5226058	5276907	5323391
4519096	4797947	4970475	5075651	5159593	5228029	5276911	5325394
4549311	4799253	4972355	5077532	5159608	5230007	5276913	5327575
4550426	4802236	4972432	5077741	5170392	5233633	5276915	5329547
4564821	4803726	4979207	5077757	5170485	5235612	5278871	5329635
4573017	4811377	4984219	5081641	5170492	5235614	5280630	5339337
4581602	4811380	4984290	5083304	5182749	5239294	5285447	D337328
4590473	4811404	4992753	5090051	5184349	5239675	5287544	D342249
4591851	4817157	4998289	5093632	5185739	5241545	5287556	D342250
4616314	4827507	5020076	5095500	5187809	5241548	5289505	D347004
4636791	4829543	5021801	5105435	5187811	5241650	5291475	D349689
4644351	4833701	5022054	5111454	5193102	5241688	5295136	RE31814
4646038	4837800	5023900	5111478	5195108	5243653	5297161	
4649543	4843633	5028885	5113400	5200655	5245611	5299228	
4654655	4847869	5030793	5117441	5203010	5245629	5301056	
4654867	4852090	5031193	5119040	5204874	5245634	5301188	

# Chapter 1: Introduction

## Table of Contents

---

- Optimization Overview . . . . . 1-1
  - Scope of This Document . . . . . 1-1
  - Document Composition . . . . . 1-1
  - CDMA LMF Product Description . . . . . 1-2
  - Online Help . . . . . 1-2
  - Why Optimize? . . . . . 1-2
  - What Is Optimization? . . . . . 1-2
  - When to Optimize . . . . . 1-3
  - Required Documents . . . . . 1-4
  - Additional Information . . . . . 1-4
  - Test Equipment Overview . . . . . 1-4
  - LMF Hardware Requirements . . . . . 1-5
  - Required Test Equipment . . . . . 1-6
  - Test Equipment Calibration . . . . . 1-6
  - Test Cable Calibration . . . . . 1-6
  - Equipment Warm-up . . . . . 1-6
  - Test Equipment List . . . . . 1-7
  - Optional Equipment . . . . . 1-10
  - Abbreviations and Acronyms . . . . . 1-11
- BTS Equipment Identification . . . . . 1-14
  - Equipment Overview . . . . . 1-14
  - Logical BTS . . . . . 1-14
  - Major Components . . . . . 1-17
  - RF Cabinet Internal FRUs . . . . . 1-18
  - Sector Configuration . . . . . 1-24
  - Power Cabinet . . . . . 1-27
  - Power Cabinet Internal FRUs . . . . . 1-28



## Scope of This Document

This document provides information pertaining to the optimization and audit tests of Motorola SC 4812ET Base Transceiver Subsystem (BTS) equipment frames equipped with trunked high-power Linear Power Amplifiers (LPAs) and their associated internal and external interfaces.

This document assumes the following prerequisites: The BTS frames and cabling have been installed per the *BTS Hardware Installation Manual*, which covers the physical “bolt down” of all SC series equipment frames, and the specific cabling configurations.

## Document Composition

This document covers the following major areas:

- Introduction, consisting of preliminary background information (such as component and subassembly locations and frame layouts) to be considered by the Cell Site Field Engineer (CFE) before optimization or tests are performed.
- Preliminary Operations, consisting of cabinet power up and power down procedures.
- Optimization/calibration, covering topics of Local Maintenance Facility (LMF) connection to the BTS equipment, Global Positioning System (GPS) Verification, test equipment setup, downloading all BTS processor boards, RF path verification, Bay Level Offset (BLO) calibration and calibration audit, and Radio Frequency Diagnostic System (RFDS) calibration.
- Acceptance Test Procedures (ATPs), consisting of ATP tests executed by the LMF and used to verify all major transmit (TX) and receive (RX) performance characteristics on all BTS equipment.
- Preparing to leave the site, presents instructions on how to properly exit customer site, ensure that all equipment is operating properly, and all work is complete according to Motorola guidelines.
- Basic troubleshooting, consisting of procedures for installation, calibration, transmit and receive tests, backplane problems, GPS failures, and module connectors.
- Appendices contain pertinent Pseudorandom Noise (PN) Offset, frequency programming, output power data tables, data sheets that are filled out manually by the CFE at the site, an optimization/ATP test matrix, BBX gain set point information, CDMA operating frequency information, PN Offset programming information, information on test equipment preparation, manual cable calibration procedures, power Delta calibration procedures, RF cabinet interconnect cable information, procedures for checking changing GPIB addresses, and procedures for downloading ROM Code from the LMF.

### CDMA LMF Product Description

The Code Division Multiple Access (CDMA) LMF is a graphical user interface (GUI) based LMF. This product is specifically designed to provide cellular communications field personnel the vehicle to support the following CDMA BTS operations:

- Installation
- Maintenance
- Calibration
- Optimization

The LMF also provides Command Line Interface (CLI) capability. Activate the CLI by clicking on a shortcut icon on the desktop. The CLI cannot be launched from the GUI, only from the desktop icon.

### Online Help

Task oriented online help is available in the LMF by clicking on **Help** from the menu bar.

### Why Optimize?

Proper optimization and calibration assures:

- Accurate downlink RF power levels are transmitted from the site.
- Accurate uplink signal strength determinations are made by the site.

### What Is Optimization?

Optimization compensates for the site-specific cabling and normal equipment variations. Cables that interconnect the BTS and Duplexer assemblies (if used), for example, are cut and installed at the time of the BTS frame installation at the site. Site optimization guarantees that the combined losses of the new cables and the gain/loss characteristics and built-in tolerances of each BTS frame do not accumulate, causing improper site operation.

Optimization identifies the accumulated loss (or gain) for all receive and transmit paths at the BTS site, and stores that value in a database.

- The RX path starts at the ancillary equipment frame RFDS RX directional coupler antenna feedline port, through the RX input port on the rear of the frame, through the DDRCs, Multicoupler Preselector Card (MPC), and additional splitter circuitry, ending at a CDMA Channel Processor (C-CCP) backplane Broad Band Transceiver (BBX) slot in the C-CCP shelf.
- A transmit path starts at the BBX, through the C-CCP backplane slot, travels through the LPA/Combiner TX Filter and ends at the rear of the input/output (I/O) Panel. If the RFDS option is added, then the TX path continues and ends at the top of the RFDS TX directional coupler antenna feedline port installed in the ancillary equipment frame.

. . . continued on next page

These values are factored in by the BTS equipment internally, leaving only site specific antenna feed line loss and antenna gain characteristics to be factored in by the CFE when determining site Effective Radiated Power (ERP) output power requirements.

Each C-CCP shelf BBX board is optimized to a specific RX and TX antenna port. (One BBX board acts in a redundant capacity for BBXs 1–12, and is optimized to all antenna ports). A single value is generated for each path, thereby eliminating the accumulation of error that would occur from individually measuring and summing the gain and loss of each element in the path.

## When to Optimize

### New Installations

After the initial site installation, the BTS must be prepared for operation. This preparation includes verifying hardware installation, initial power up, and GPS verification. Basic alarm tests are also addressed.

A calibration audit of all RF transmit paths is performed to verify factory calibration.

A series of ATP CDMA verification tests are covered using the actual equipment set up. An ATP is also required before the site can be placed in service.

### Site Expansion

Optimization is also required after expansion of a site.

### Periodic Optimization

Periodic optimization of a site may also be required, depending on the requirements of the overall system.

### Repaired Sites

Verify repair(s) made to the BTS by consulting an Optimization/ATP Test Matrix table. This table outlines the specific tests that must be performed *anytime* a BTS subassembly or RF cable associated with it is replaced.



#### **IMPORTANT**

Refer to Appendix B for detailed basic guideline tables and detailed Optimization/ATP Test Matrix.

**Required Documents**

The following documents are required to perform optimization of the cell site equipment:

- Site document (generated by Motorola systems engineering), which includes:
  - General site information
  - Floor plans
  - Power levels
  - Site PN
  - Site paging and traffic channel allocation
  - Board placement
  - Site wiring lists
  - Cell-site Data Files (CDF)
- Demarcation document (scope of work agreement)
- Equipment manuals for non-Motorola test equipment.

**Required Documentation**

For other information, refer to the following manuals:

- Demarcation Document (Scope of Work Agreement)
- *CDMA LMF Operator’s Guide*; 68P64114A78
- *CDMA RFDS Hardware Installation* manual; 68P64113A93
- *CDMA RFDS User’s Guide*
- Equipment Manuals for non-Motorola test equipment
- *SC4812ET Field Replacable Units Guide* Motorola part number 68P09253A48
- *SC 4812ET RF & Power Cabinet Hardware Installation Manual* Motorola part number 68P09253A94
- *LMF CLI Commands R16.X* Motorola part number 68P09253A56

**Test Equipment Overview**

The LMF is used in conjunction with Motorola recommended test equipment, and it is a part of a “calibrated test set.” To ensure consistent, reliable, and repeatable optimization test results, only recommended test equipment supported by the LMF must be used to optimize the BTS equipment. Table 1-1 outlines the supported test equipment that meets the technical criteria required for BTS optimization.

<b>Table 1-1: CDMA LMF Test Equipment Support Table</b>	
<b>Item</b>	<b>Description</b>
Hewlett Packard, model HP 8921A	Cellular communications analyzer (includes 83203B CDMA interface option)
Agilent E4406A Analyzer with Agilent E4432B Generator	Used for both IS-95A/B and CDMA 2000 testings

... continued on next page



<b>Item</b>	<b>Description</b>
Advantest R3267 Analyzer with Advantest R3562 Generator	Used for both IS-95A/B and CDMA 2000 testings
Hewlett Packard, model HP 83236A	PCS interface for PCS band
Hewlett Packard, model HP 8935	Cellular communications analyzer
Motorola CyberTest	Cellular communications analyzer
Advantest R3465 with 3561 CDMA option	Cellular communications analyzer
Gigatronix 8541C	Power meter
HP437B	Power meter

To ensure consistent, reliable, and repeatable optimization test results, test equipment meeting the following technical criteria should be used to optimize the BTS equipment. You can, of course, substitute test equipment with other test equipment models supported by the LMF *meeting the same technical specifications.*

**LMF Hardware Requirements**

An LMF computer platform that meets the following requirements (or better) is recommended:

- Notebook computer
- 266 MHz (32-bit CPU) Pentium processor
- 4 GB internal hard disk drive
- Color display with 1024 x 768 pixel resolution and capability to display more than 256 colors
- Memory requirements:
  - Minimum required RAM: 96 MB
  - Recommended RAM:
    - 128 MB for Windows 98 SE
    - 256 MB for Windows 2000
- CD ROM drive and 3 1/2 inch floppy drive
- 56 kbps V.90Modem
- Serial port (COM 1)
- Parallel port (LPT 1)
- PCMCIA Ethernet interface card (for example, 3COM Etherlink III) with a 10Base-T-to-coax adapter

. . . continued on next page

- Windows 98SE operating system or Windows 2000 operating system

**NOTE**

If 800 x 600 pixel resolution is used, the LMF window must be maximized after it is displayed.

**Required Test Equipment**

To ensure consistent, reliable, and repeatable optimization test results, test equipment meeting the following technical criteria should be used to optimize the BTS equipment. You can, of course, substitute test equipment with other test equipment models supported by the LMF *meeting the same technical specifications.*

**NOTE**

During manual testing, you can substitute test equipment with other test equipment models not supported by the LMF, *but those models must meet the same technical specifications.*

*The customer has the responsibility of accounting for any measurement variances and/or additional losses/inaccuracies that can be introduced as a result of these substitutions. Before beginning optimization or troubleshooting, make sure that the test equipment needed is on hand and operating properly.*

**Test Equipment Calibration**

Optimum system performance and capacity depend on regular equipment service, calibration, and characterization prior to BTS optimization. Follow the original equipment manufacturer (OEM) recommended maintenance and calibration schedules closely.

**Test Cable Calibration**

Equipment test cables are very important in optimization. Motorola recommends that the cable calibration be run at every BTS with the test cables attached. This method compensates for test cable insertion loss within the test equipment itself. No other allowance for test cable insertion loss needs to be made during the performance of tests.

Another method is to account for the loss by entering it into the LMF during the optimization procedure. This method requires accurate test cable characterization in a shop. The cable should be tagged with the characterization information prior to field optimization.

### Equipment Warm-up

After arriving at the a site, the test equipment should be plugged in and turned on to allow warm up and stabilization to occur for as long as possible. The following pieces of test equipment must be warmed-up for *a minimum of 60 minutes* prior to using for BTS optimization or RFDS calibration procedures.

- Communications test set
- Rubidium time base
- Power meter

### Test Equipment List

The following pieces of test equipment are required during the optimization procedure. Common assorted tools like screwdrivers and frame keys are not listed but are still required. Read the owner's manual on all of the following major pieces of test equipment to understand their individual operation prior to use in optimization.

#### NOTE

Always refer to specific OEM test equipment documentation for detailed operating instructions.

#### 10BaseT/10Base2 Converter

##### **Ethernet LAN transceiver** (*part of CGDSL MFCPQ1700*)

- PCMCIA Ethernet Adpater + Ethernet UTP adapter: 3COM model – Etherlink III 3C589B

Transition Engineering model E-CX-TBT-03 10BaseT/10Base2 converter

#### NOTE

Xircom model PE3-10B2 or equivalent can also be used to interface the LMF Ethernet connection to the frame.

#### RS-232 to GPIB Interface

- National Instruments GPIB-232-CT with Motorola CGDSEDN04X RS232 serial null modem cable (see Figure 1-1) or equivalent; used to interface the LMF to the test equipment.
- *Standard RS-232 cable can be used with the following modifications:*
  - This solution passes only the three minimum electrical connections between the LMF and the GPIB interface. The control signals are jumpered as enabled on both ends of the RS-232 cable (9-pin D). TX and RX signals are crossed as null modem effect. Pin 5 is the ground reference.

. . . continued on next page

- Short pins 7 and 8 together, and short pins 1, 4, and 6 together on each connector.

**Figure 1-1: Null Modem Cable Detail**

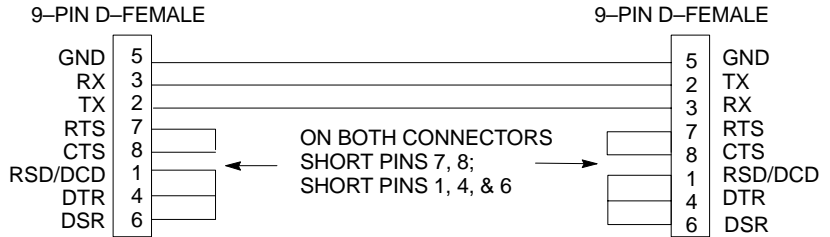

FW00362

**Model SLN2006A MMI Interface Kit**

- Motorola Model TRN9666A null modem board. Connectors on opposite sides of the board must be used as this performs a null modem transformation between cables. This board can be used for 10-pin to 8-pin, 25-pin to 25-pin and 10-pin to 10-pin conversions.
- Motorola 30-09786R01 MMI cable or equivalent ; used to interface the LMF serial port connection to GLI2, CSM and LPA debug serial ports.
- 25 pin D to 25 pin D serial cable from PC to null modem board.

**Communications System Analyzer**

The communication system analyzer is used during optimization and testing of the RF communications portion of BTS equipment and provides the following functions:

- (1) Frequency counter
- (2) RF power meter (average and code domain)
- (3) RF Signal generator (capable of CDMA modulation)
- (4) Spectrum analyzer
- (5) CDMA code domain analyzer

The following types of communication system analyzers are currently supported by the LMF:

- HP8921A/600 Analyzer – Including 83203B CDMA Interface, manual control system card, and 83236A/B PCS Interface for 1900 MHz BTSs.
- Advantest R3465 Analyzer – Including R3561L test source unit
- Advantest R3267 Analyzer – Including R3562 test source unit
- Agilent E4406A Analyzer – including E4432 test source unit
- HP8935 Analyzer
- CyberTest Communication Analyzer

**GPIB Cables**

- Hewlett Packard 10833A or equivalent; 1 to 2 meters (3 to 6 feet) long used to interconnect test equipment and LMF terminal.

. . . continued on next page

### Power Meter

One of the following power meters is required for TX calibration and audit if an HP8921A or Advantest R3465 analyzer is used:

- Hewlett Packard Model HP HP437B with HP8481A power sensor
- Gigatronix model 8541C with model 80601A power sensor

### Timing Reference Cables

- *Two* BNC–male to BNC–male RG316 cables; 3 meters (10 ft.) long, used to interconnect the HP8921A/600 or Advantest R3465 communications analyzer to the CSM front panel timing references in the BTS.

#### NOTE

*Two* Huber & Suhner 16MCX/11BNC/K02252D or equivalent; right angle MCX–male to standard BNC–male RG316 cables; 3m long are required to interconnect the HP8921A/600 communications analyzer to SGLN4132A and SGLN1145A CSM board timing references.

- BNC “T” adapter with 50 ohm termination.

#### NOTE

This BNC “T” adapter (with 50 ohm termination) is required to connect between the HP 8921A/600 (or Advantest R3465) EVEN SECOND/SYNC IN and the BNC cable. The BNC cable leads to the 2–second clock connection on the TIB. Erroneous test results may occur if the “T” adapter with the 50 ohm termination is not connected.

### Digital Multimeter

- Fluke model 8062A with Y8134 test lead kit or equivalent; used for precision DC and AC measurements, requiring 4–1/2 digits.

### Directional Coupler

- Narda model 30661 30 dB (Motorola part no. 58D09732W01) coupler terminated with two Narda Model 375BN–M loads, or equivalent.

### RF Attenuators

- 20 dB fixed attenuators, 20 W (Narda 768–20); used with test cable calibrations or during general troubleshooting procedures.
- Narda Model 30445 30 dB (Motorola Part No. 58D09643T01) coupler terminated with two Narda Model 375BN–M loads, or equivalent.

**Miscellaneous RF Adapters, Loads, etc**

- As required to interface test cables and BTS equipment and for various test set ups. Should include at least two 50 Ohm loads (type N) for calibration and one RF short, two N-type female-to-female adapters.

**High-impedance Conductive Wrist Strap**

- Motorola model 42-80385A59; used to prevent damage from Electrostatic Discharge (ESD) when handling or working with modules.

**RF Load** (at least three for trunked cabinets)

- 100 W non-radiating RF load; used (as required) to provide dummy RF loading during BTS transmit tests.

**RF Network Box (and calibrated cables)**

- Motorola model SGLN5531A 18:3 Passive Antenna Interface used to interface test equipment to the BTS receive and transmit antenna inputs during optimization/ATP or general troubleshooting procedures.

**Optional Equipment****Frequency Counter**

- Stanford Research Systems SR620 or equivalent. If direct measurement of the 3 MHz or 19.6608 MHz references is required.

**Spectrum Analyzer**

- Spectrum Analyzer (HP8594E with CDMA personality card) or equivalent; required for tests other than standard Receive band spectral purity and TX LPA IM reduction verification tests performed by the LMF.

**Local Area Network (LAN) Tester**

- Model NETcat 800 LAN troubleshooter (or equivalent); used to supplement LAN tests using the ohm meter.

**Span Line (T1/E1) Verification Equipment**

- As required for local application

**RF Test Cable (if not Provided with Test Equipment)**

- Motorola model TKN8231A; used to connect test equipment to the BTS transmitter output during optimization or during general troubleshooting procedures.

**Oscilloscope**

- Tektronics model 2445 or equivalent; for waveform viewing, timing, and measurements or during general troubleshooting procedure.

. . . continued on next page

**2-way Splitter**

- Mini-Circuits model ZFSC-2-2500 or equivalent; provide the diversity receive input to the BTS

**High Stability 10 MHz Rubidium Standard**

- Stanford Research Systems SR625 or equivalent. Required for CSM and Low Frequency Receiver/High Stability Oscillator (LFR/HSO) frequency verification.

**Abbreviations and Acronyms**

<b>Table 1-2: Abbreviations and Acronyms</b>	
<b>Acronym</b>	<b>Definition</b>
ACLC	AC Load Center
ASU	Antenna Selection Unit
AMR	Alarm Monitor Reporting
ATP	Acceptance Test Plan
BBX	Broadband Transceiver
BLO	Bay Level Offset
BTS	Base Transceiver Subsystem
CBSC	Centralized Base Station Controller
C-CCP	Combined CDMA Channel Processor
CCD	CDMA Clock Distribution
cdf	command data file
CDMA	Code Division Multiple Access
CE	Channel Element
CHI	Concentration Highway Interface
CLI	Command Line Interface
CIO	Combiner Input/Output
CMR	Cellular Manual Revision
CSM	Clock Synchronization Manager
CSU	Clock Synchronization Unit
DBPF	Dual Bandpass Filter
DBM	Debug Monitor
DLM	Download Manager
DMAC	Digital Metering and Alarm Control (also see MAP)
DRDC	Duplexer/RX Filter/Directional Coupler
DSP	Digital Signal Processor
EMPC	Expansion Multicoupler Preselector Card
FRU	Field Replaceable Unit
FSI	Frame Status Indicator

... continued on next page

<b>Table 1-2: Abbreviations and Acronyms</b>	
<b>Acronym</b>	<b>Definition</b>
FWTIC	Fixed Wireless Terminal Interface Card
GFCI	Ground Fault Connection Interrupt
GLI 2	Group Line Interface II
GPS	Global Positioning System
GUI	Graphical User Interface
HSO	High Stability Oscillator
IFM	Integrated Frame Modem
I&Q	Interphase and Quadrature
ISB	InterShelf Bus
LAPD	Link Access Protocol “D”
LFR	LORAN–C Frequency Receiver
LMF	Local Maintenance Facility
LORAN	LONg RANGE Navigational
LPA	Linear Power Amplifier
MAP	Meter Alarm Panel (also referred to as DMAC)
MCC	Multi–Channel CDMA
MGLI	Master Group Line Interface
MM	Mobility Manager
MMI	Man Machine Interface
MPC	Multicoupler Preselector Card
oos	Out–of–Service
OMCR	Operations Maintenance Center – Radio
PC	Personal Communication System
PDA	Personal Communication System Controller
PN	Pseudo–random Noise
QPSK	Quadrature Phase Shift Keyed
RFDS	Radio Frequency Diagnostic Subsystem
RGPS	Remote Global Positioning System
RSSI	Received Signal Strength Indicator
SCAP	Super Cell Application Protocol
TCH	Traffic Channel
TCP	Traffic Channel
TMPC	Traffic Channel
TSIC	Traffic Channel
TSI	Time Slot Interchanger



## Equipment Overview

The SC 4812ET BTS consists of an RF Cabinet that is an outdoor, weatherized version of the SC 4812T. The RF cabinet is powered by 27 Vdc and each cabinet has the capability to support up to 4 carriers (at 3 sector) or 2 carriers (at 6 sector).

The RF Cabinet houses the fan modules, C-CCP, LPA modules, LPA trunking backplane, Bandpass 2:1 & 4:1 Combiners, Duplexer/Receive Filter/Directional Couplers (DRDC) and a DC Power distribution assembly. The Power Cabinet (PC) provides +27 Vdc distribution and battery backup for the SC 4812ET. The Power Cabinet houses batteries, battery heaters, rectifiers, an AC Load Center (ACLC), a power distribution assembly, and two duplexed GFCI convenience outlets.

### C-CCP Shelf Card/Module Device ID Numbers

All cards/modules/boards in the frames at a single site, assigned to a single BTS number, are also identified with unique Device ID numbers dependent upon the Frame ID number in which they are located. Refer to Table 1-3 and Table 1-4 for specific C-CCP Shelf Device ID numbers.

**Table 1-3: C-CCP Shelf/Cage Card/Module Device ID Numbers (Top Shelf)**

Frame #	Card/Module ID Number (Left to Right)																		
	Power (PS-1)	Power (PS-2)	Power (PS-3)	AMR -1	GLI2 -1	MCC						BBX						BBX -R	MPC/EMPC -1
1	-	-	-	1	1	1	2	3	4	5	6	1	2	3	4	5	6	R1	-
101	-	-	-	101	101	101	102	103	104	105	106	101	102	103	104	105	106	R101	-
201	-	-	-	201	201	201	202	203	204	205	206	201	202	203	204	205	206	R201	-
301	-	-	-	301	301	301	302	303	304	305	306	301	302	303	304	305	306	R301	-

**Table 1-4: C-CCP Shelf/Cage Card/Module Device ID Numbers (Bottom Shelf)**

Frame #	Card/Module ID Number (Left to Right)																					
	HSO/LFR	CSM -1	CSM -2	CCD A	CCD B		AMR -2	GLI2-2	MCC						BBX						SW	MPC/EMPC -2
1	-	1	2	-	-	-	2	2	7	8	9	10	11	12	7	8	9	10	11	12	-	-
101	-	101	102	-	-	-	102	102	107	108	109	110	111	112	107	108	109	110	111	112	-	-
201	-	201	202	-	-	-	202	102	207	208	209	210	211	212	207	208	209	210	211	212	-	-
301	-	301	302	-	-	-	302	102	307	308	309	310	311	312	307	308	309	310	311	312	-	-

**Major Components**

The major components that make up the Motorola SC 4812ET are illustrated in this section: the RF Cabinet (see Figure 1-2) and the Power Cabinet (see Figure 1-9).

**Figure 1-2: SC 4812ET RF Cabinet**

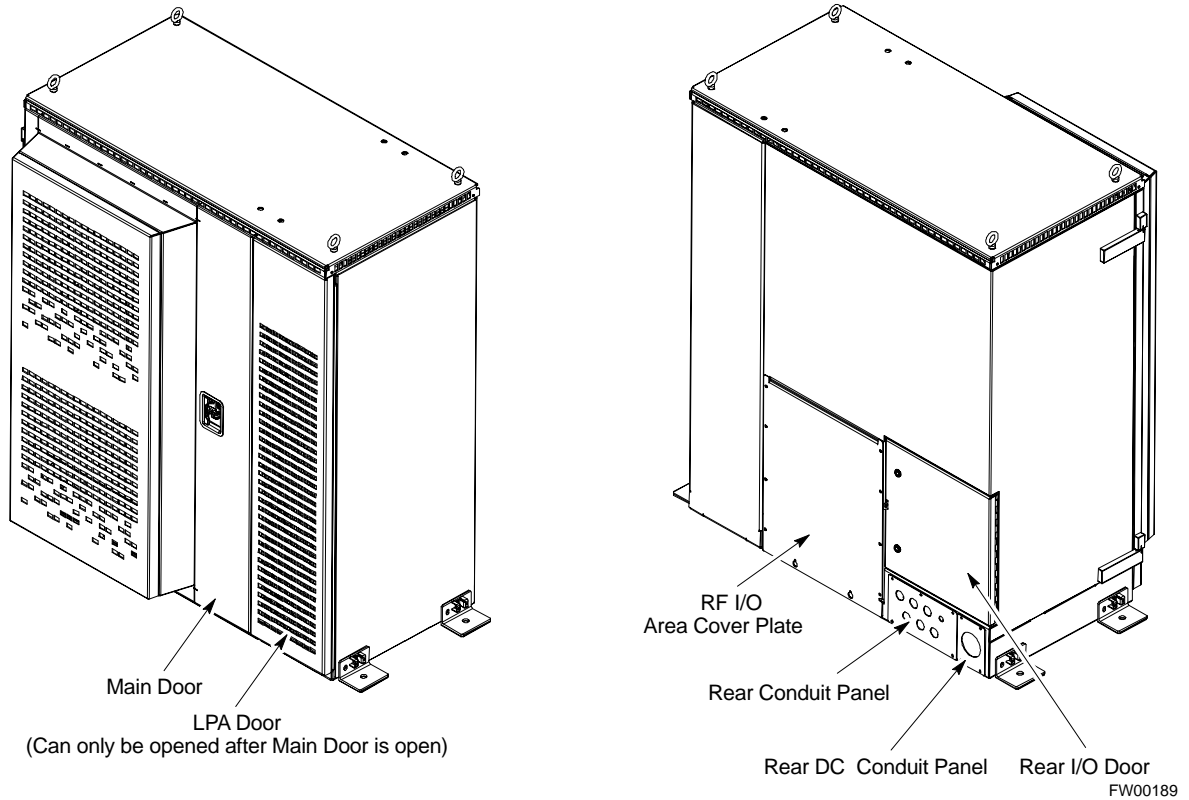

RF Cabinet Internal FRUs

Figure 1-3 shows the location of the Internal Field Replaceable Units (FRUs). A brief description of each Internal FRU is found in the following paragraphs.

Figure 1-3: RF Cabinet Internal FRUs

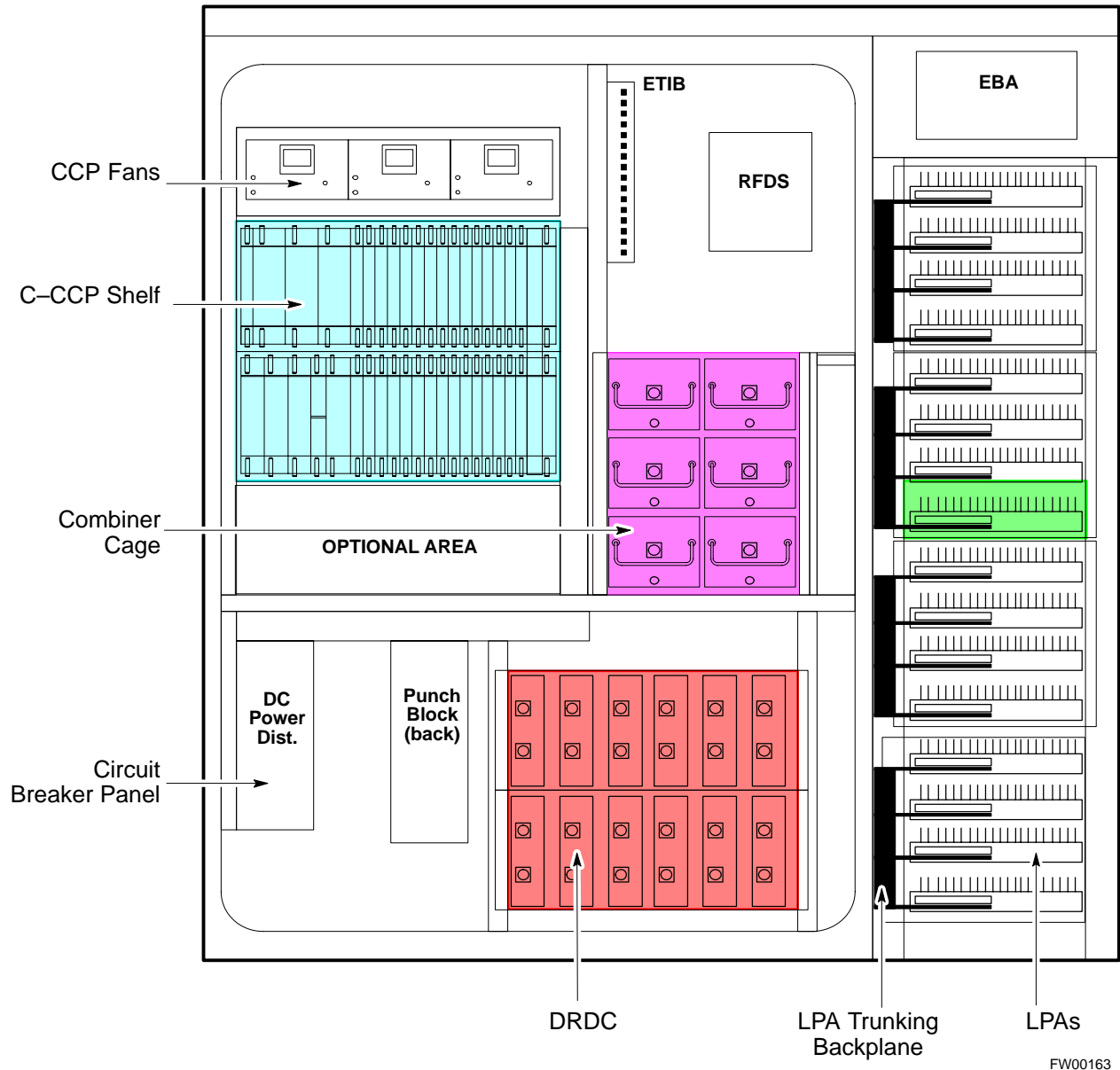

**Duplexer/RX Filter Directional Coupler**

The DRDC combines, in a single module, the functions of antenna duplexing, receive band pass filtering, and surge protection (see Figure 1-7).

**Combiner Cage (2:1, 4:1, or Band pass Filter)**

The Combiner Cage holds the transmit band pass filters, 2:1 combiners, or 4:1 combiners, depending on system configuration.

**Combined CDMA Channel Processor Shelf**

The C-CCP shelf contains the following (see Figure 1-4):

- High Stability Oscillator (HSO) or Low Frequency Receiver (LFR) card (1)
- Clock Synchronization Manager (CSM) card
- CDMA Clock Distribution (CCD) cards (2)
- Power Supply cards (2 minimum, 3 maximum)
- Multicoupler Preselector Cards (MPC) or Expansion Multicoupler Preselector Cards (EMPC) (2)
- Alarm Monitoring and Reporting (AMR) cards (2)
- Multi Channel CDMA (MCC8E, MCC24E or MCC-1X) cards (up to 12)
- Broadband Transceiver (BBX2 or BBX-1X) cards (up to 13)
- Combined Input/Output (CIO) card (1)
- Group Line Interface (GLI2) cards (2)
- BBX Switch card (1)
- Modem (optional)
- Filler Panels (as required)
- Fan Module (3)

Figure 1-4: SC 4812ET C-CCP Shelf

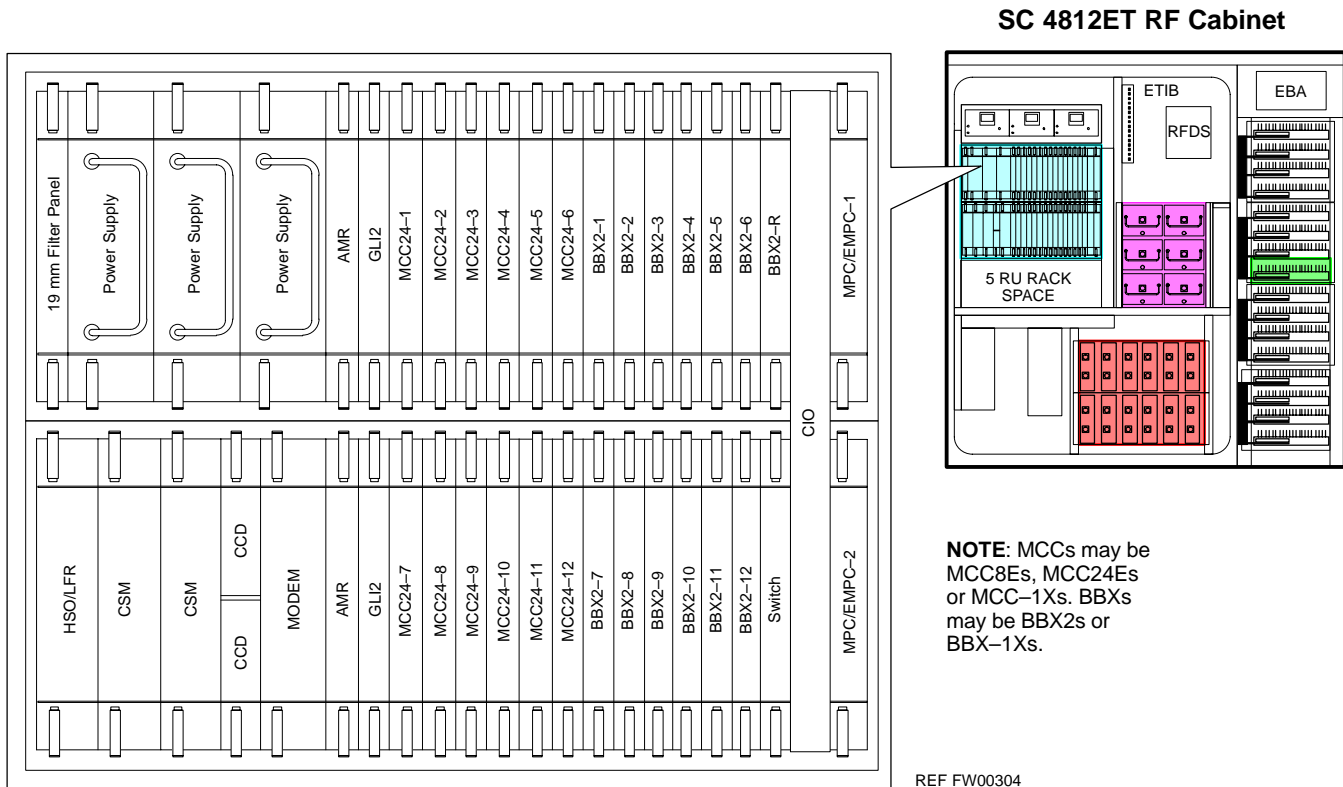

**Punch Block**

The Punch Block is the interface point of the RF Cabinet between the T1/E1 span lines, the Customer I/O, alarms, multi-cabinet timing (RGPS and HSO), and Pilot Beacon control (optional). (see Figure 1-6).

**Span I/O Board**

The Span I/O Board provides the interface for the span lines from the CSU to the C-CCP backplane (see Figure 1-6).

**RF Diagnostic Subsystem**

The RFDS provides the capability for remotely monitoring the status of the SC 4812ET RF Transmit and Receive paths (Figure 1-7).

**Heat Exchanger**

The Heat Exchanger provides cooling to the internal compartment of the RF Cabinet. The fan speed of the heat exchangers adjusts automatically with temperature. The Heat Exchanger is located in the primary front door of the RF Cabinet.

**SC 4812ET Interface Board (ETIB) & LPA Control Brd (LPAC)**

The ETIB is an interconnect board showing status LEDs for the RF Cabinet, as well as providing secondary surge protection. The LPAC board provides the interface for the LPA connection.

**SC 4812ET Trunking Backplane**

The Trunking Backplane contains a complex passive RF network that allows RF signals to share the resources of a bank of four LPAs. It also provides DC Power and digital interconnect.

**Figure 1-5:** SC 4812ET Intercabinet I/O Detail (Rear View)

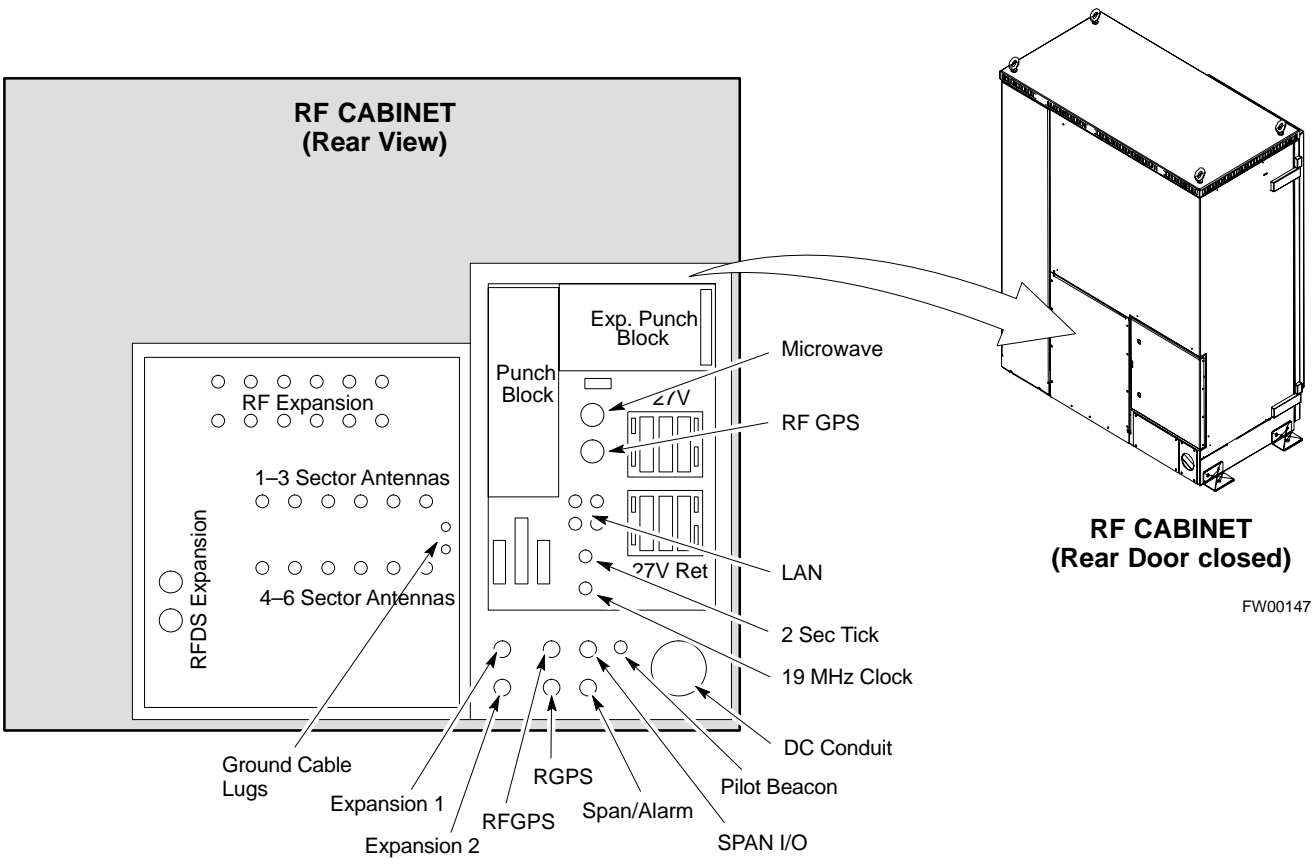
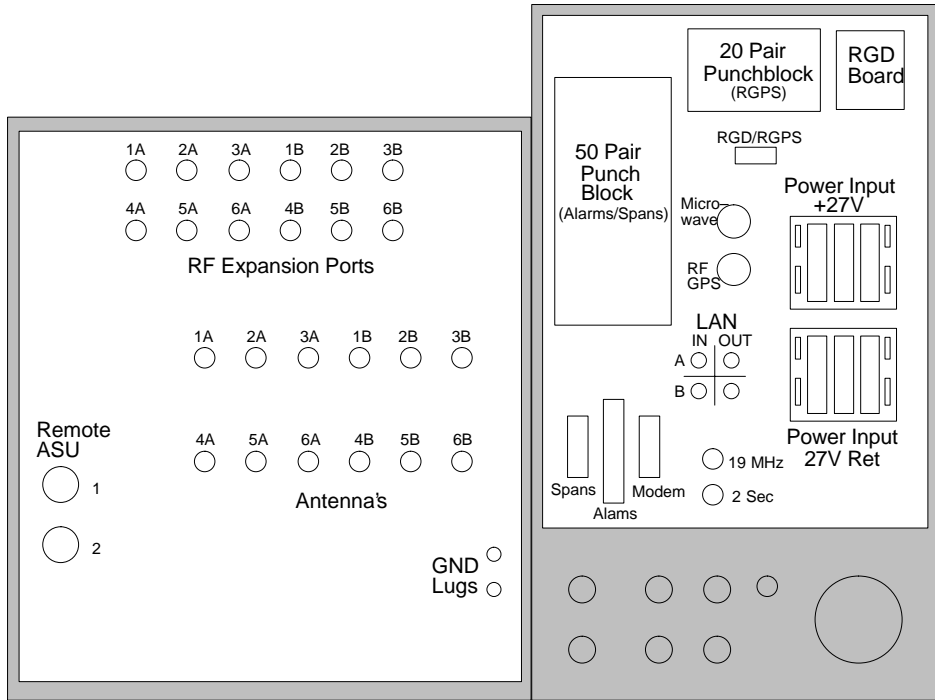

Figure 1-6: SC 4812ET I/O Plate Diagram



FW00171

# BTS Equipment Identification – continued

Figure 1-7: RFDS Location in an SC 4812ET RF Cabinet

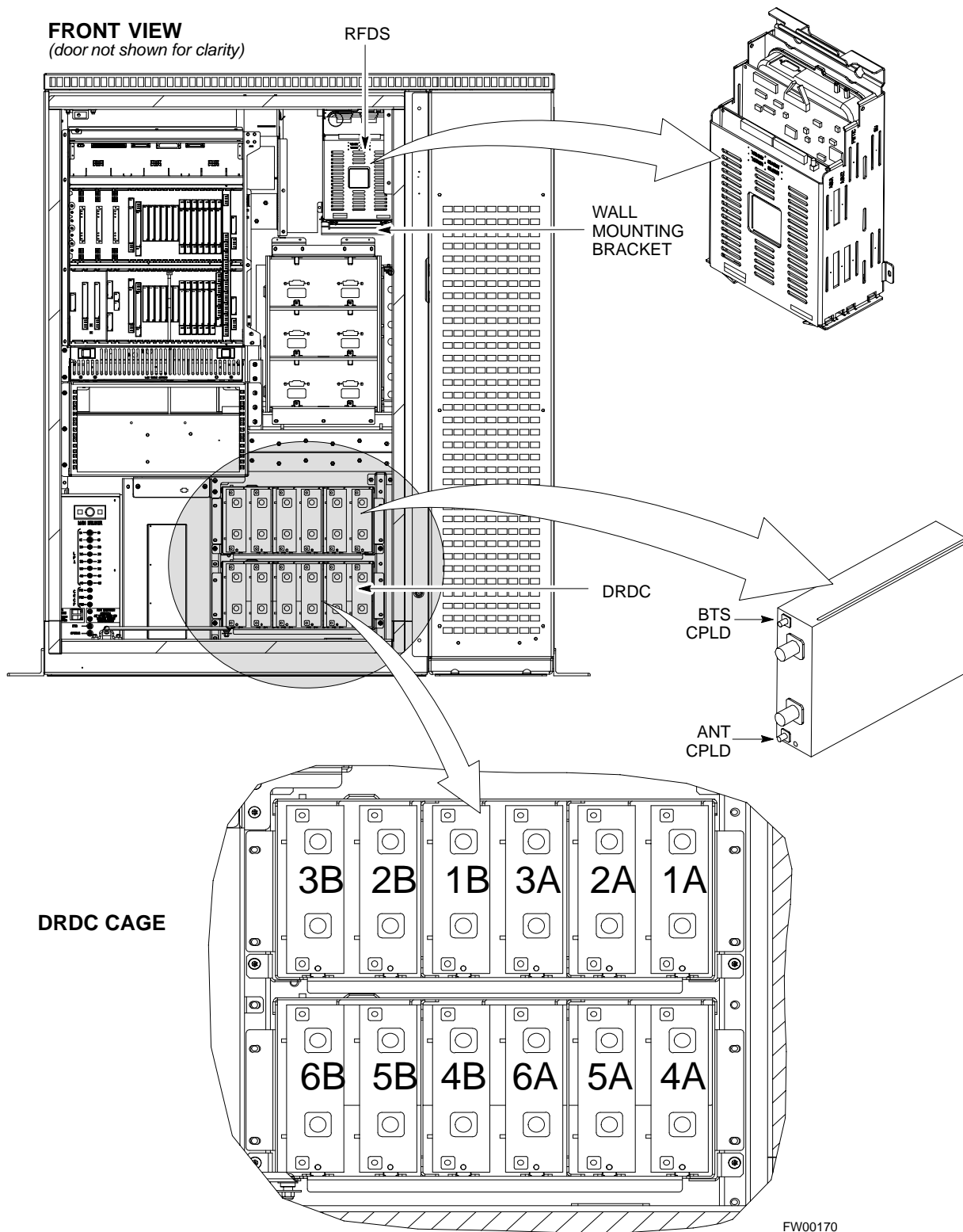



**Sector Configuration**

There are a number of ways to configure the BTS frame. Table 1-5 outlines the basic requirements. When carrier capacity is greater than two, a 2:1 or 4:1 cavity combiner must be used. For one or two carriers, bandpass filters or cavity combiners may be used, depending on sectorization and channel sequencing.

<b>Table 1-5: BTS Sector Configuration</b>			
<b>Number of carriers</b>	<b>Number of sectors</b>	<b>Channel spacing</b>	<b>Filter requirements</b>
1	3 or 6	N/A	Bandpass Filter, Cavity Combiner (2:1 or 4:1)
2	6	Non-adjacent	Cavity Combiner (2:1 Only)
2	6	Adjacent	Dual Band Pass Filter
2	3	Non-adjacent	Cavity Combiner (2:1 or 4:1)
2	3	Adjacent	Bandpass Filter
3,4	3	Non-adjacent	Cavity Combiner (2:1 or 4:1)
3,4	3	Adjacent	Cavity Combiner (2:1 Only)

The matrix in Table 1-6 shows a correlation between the various sector configurations and BBX cards.

**NOTE**

In Table 1-6, BBXs may be BBX2s or BBX-1Xs.

**BTS Equipment Identification – continued**

<b>Table 1-6: Sector Configurations</b>							
<b>Config Ref. No.</b>	<b>Description</b>						
<b>1</b>	<b>3-Sector/2-ADJACENT Carriers</b> – The configuration below maps TX with optional 2:1 cavity combiners for 3 sectors/2 carriers for <i>adjacent</i> channels. Note that 2:1 cavity combiners are used (6 total).						
	<b>TX1</b>	<b>TX2</b>	<b>TX3</b>	<b>TX4</b>	<b>TX5</b>	<b>TX6</b>	<b>Carrier#</b>
	BBX-1 N/A	BBX-2 N/A	BBX-3 N/A	N/A BBX-4	N/A BBX-5	N/A BBX-6	1 2
<b>2</b>	<b>6-Sector/2-NON-ADJACENT Carriers</b> – The configuration below maps TX with 2:1 cavity combiners for 6 sectors/2 carriers for <i>non-adjacent</i> channels.						
	<b>TX1</b>	<b>TX2</b>	<b>TX3</b>	<b>TX4</b>	<b>TX5</b>	<b>TX6</b>	<b>Carrier#</b>
	BBX-1 BBX-7	BBX-2 BBX-8	BBX-3 BBX-9	BBX-4 BBX-10	BBX-5 BBX-11	BBX-6 BBX-12	1 2
<b>3</b>	<b>3-Sector/2-NON-ADJACENT Carriers</b> – The configuration below maps TX with 2:1 cavity combiners for 3 sectors/2 carriers for <i>non-adjacent</i> channels.						
	<b>TX1</b>	<b>TX2</b>	<b>TX3</b>	<b>TX4</b>	<b>TX5</b>	<b>TX6</b>	<b>Carrier#</b>
	BBX-1 BBX-7	BBX-2 BBX-8	BBX-3 BBX-9	N/A N/A	N/A N/A	N/A N/A	1 2
<b>4</b>	<b>3-Sector/4-ADJACENT Carriers</b> – The configuration below maps TX with 2:1 cavity combiners for 3 sector/4 carriers for <i>adjacent</i> channels.						
	<b>TX1</b>	<b>TX2</b>	<b>TX3</b>	<b>TX4</b>	<b>TX5</b>	<b>TX6</b>	<b>Carrier#</b>
	BBX-1	BBX-2	BBX-3	N/A	N/A	N/A	1
	BBX-7	BBX-8	BBX-9	N/A	N/A	N/A	2
	N/A	N/A	N/A	BBX-4	BBX-5	BBX-6	3
N/A	N/A	N/A	BBX-10	BBX-11	BBX-12	4	
<b>5</b>	<b>3-Sector / 2-ADJACENT Carriers</b> – The configuration below maps TX with bandpass filters for 3 sectors/2 carriers for <i>adjacent</i> channels.						
	<b>TX1</b>	<b>TX2</b>	<b>TX3</b>	<b>TX4</b>	<b>TX5</b>	<b>TX6</b>	<b>Carrier#</b>
	BBX-1 N/A	BBX-2 N/A	BBX-3 N/A	N/A BBX-7	N/A BBX-8	N/A BBX-9	1 2
<b>6</b>	<b>3-Sector/3 or 4-NON-ADJACENT Carriers</b> – The configuration below maps TX with 4:1 cavity combiners for 3 sectors/3 or 4 carriers for <i>non-adjacent</i> channels.						
	<b>TX1</b>	<b>TX2</b>	<b>TX3</b>	<b>TX4</b>	<b>TX5</b>	<b>TX6</b>	<b>Carrier#</b>
	BBX-1	BBX-2	BBX-3	N/A	N/A	N/A	1
	BBX-7	BBX-8	BBX-9	N/A	N/A	N/A	2
	BBX-4	BBX-5	BBX-6	N/A	N/A	N/A	3
BBX-10	BBX-11	BBX-12	N/A	N/A	N/A	4	
<b>7</b>	<b>6-Sector/1-Carrier</b> – The configuration below maps TX with either bandpass filters or 2:1 cavity combiners for 6 sector/1 carrier.						
	<b>TX1</b>	<b>TX2</b>	<b>TX3</b>	<b>TX4</b>	<b>TX5</b>	<b>TX6</b>	<b>Carrier#</b>
	BBX-1	BBX-2	BBX-3	BBX-4	BBX-5	BBX-6	1

**BTS Equipment Identification – continued**

**Figure 1-8: SC4812ET LPA Configuration with Combiners/Filters**

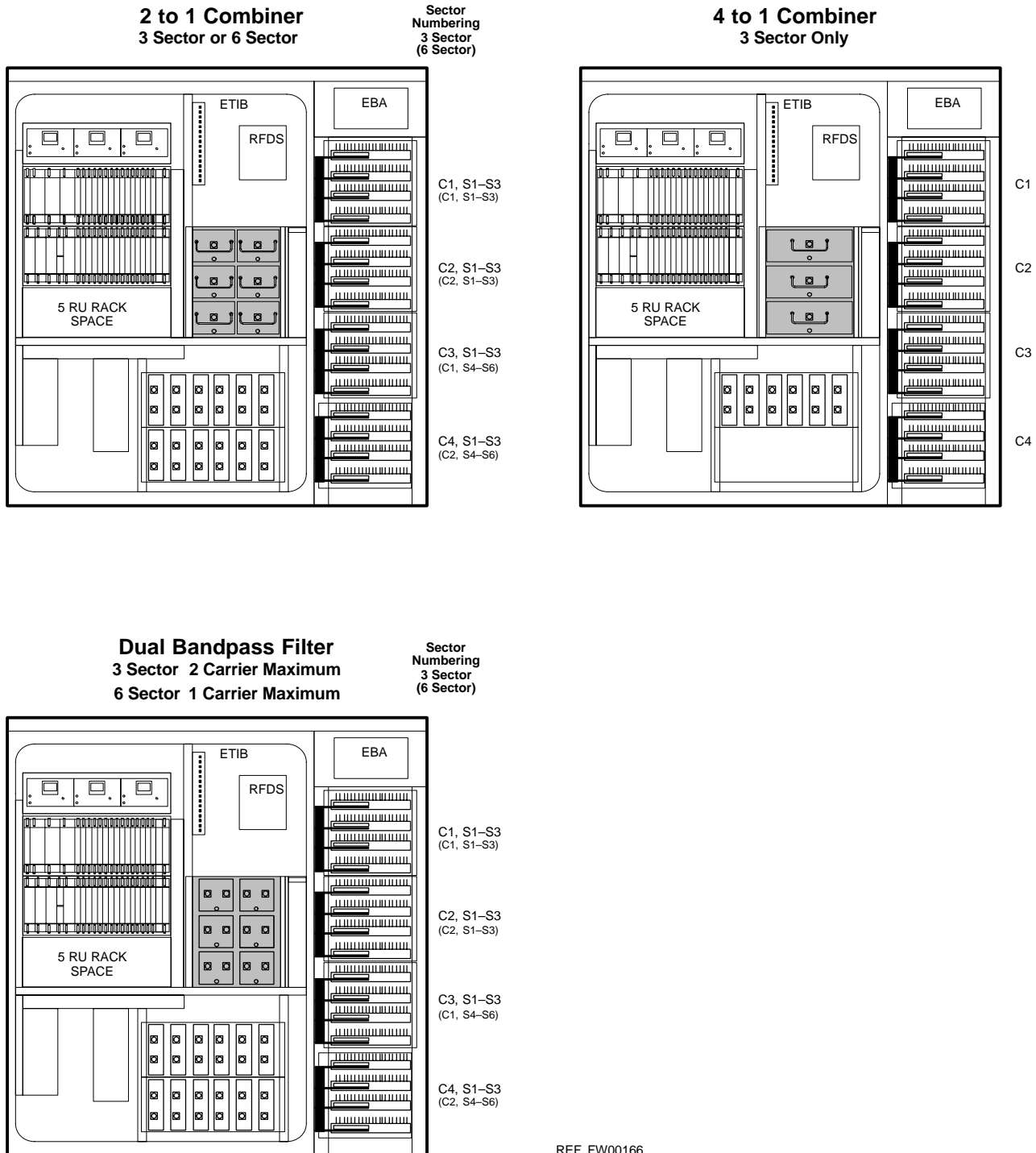

Power Cabinet

Figure 1-9 illustrates the Power Cabinet design.

Figure 1-9: Power Cabinet

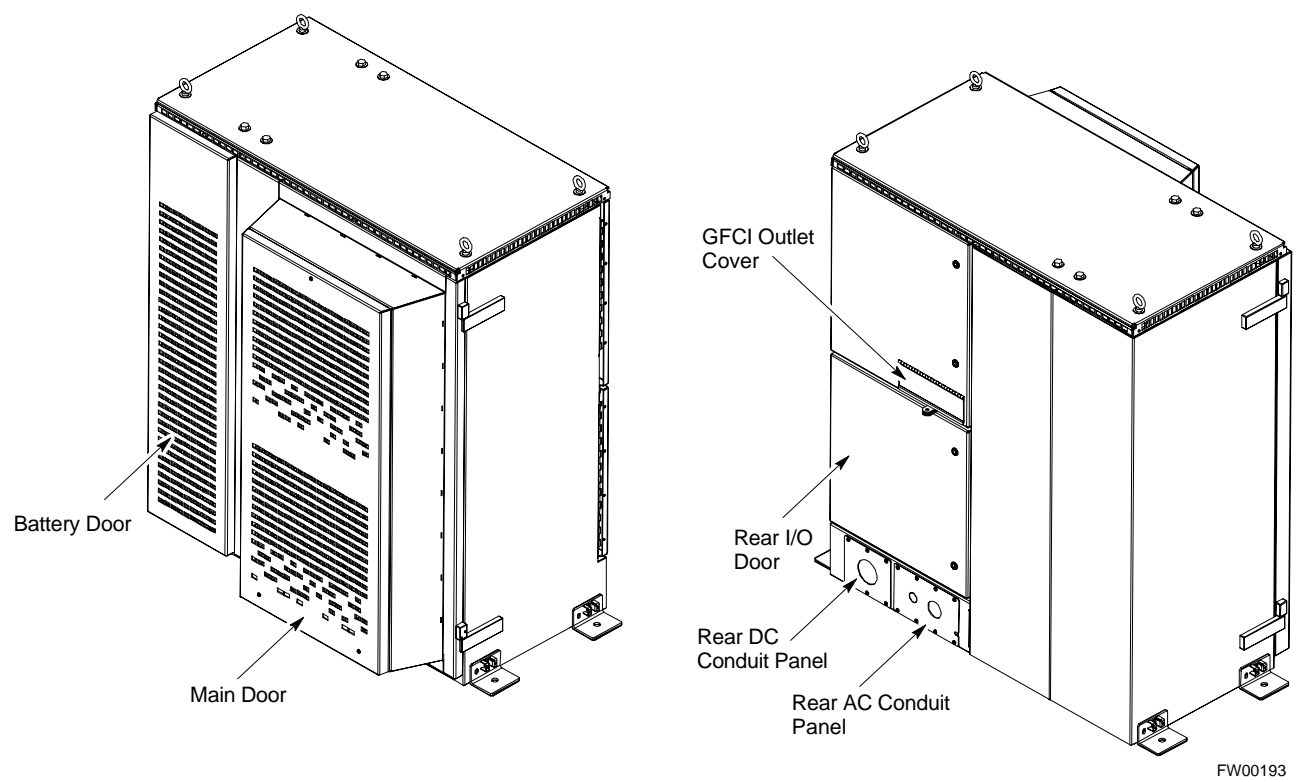

FW00193

**Power Cabinet Internal FRUs**

Figure 1-10 shows the location of the Internal Field Replaceable Units (FRUs). A brief description of each Internal FRU is found in the following paragraphs.

**Figure 1-10:** Power Cabinet with Batteries Installed (Doors Removed for Clarity)

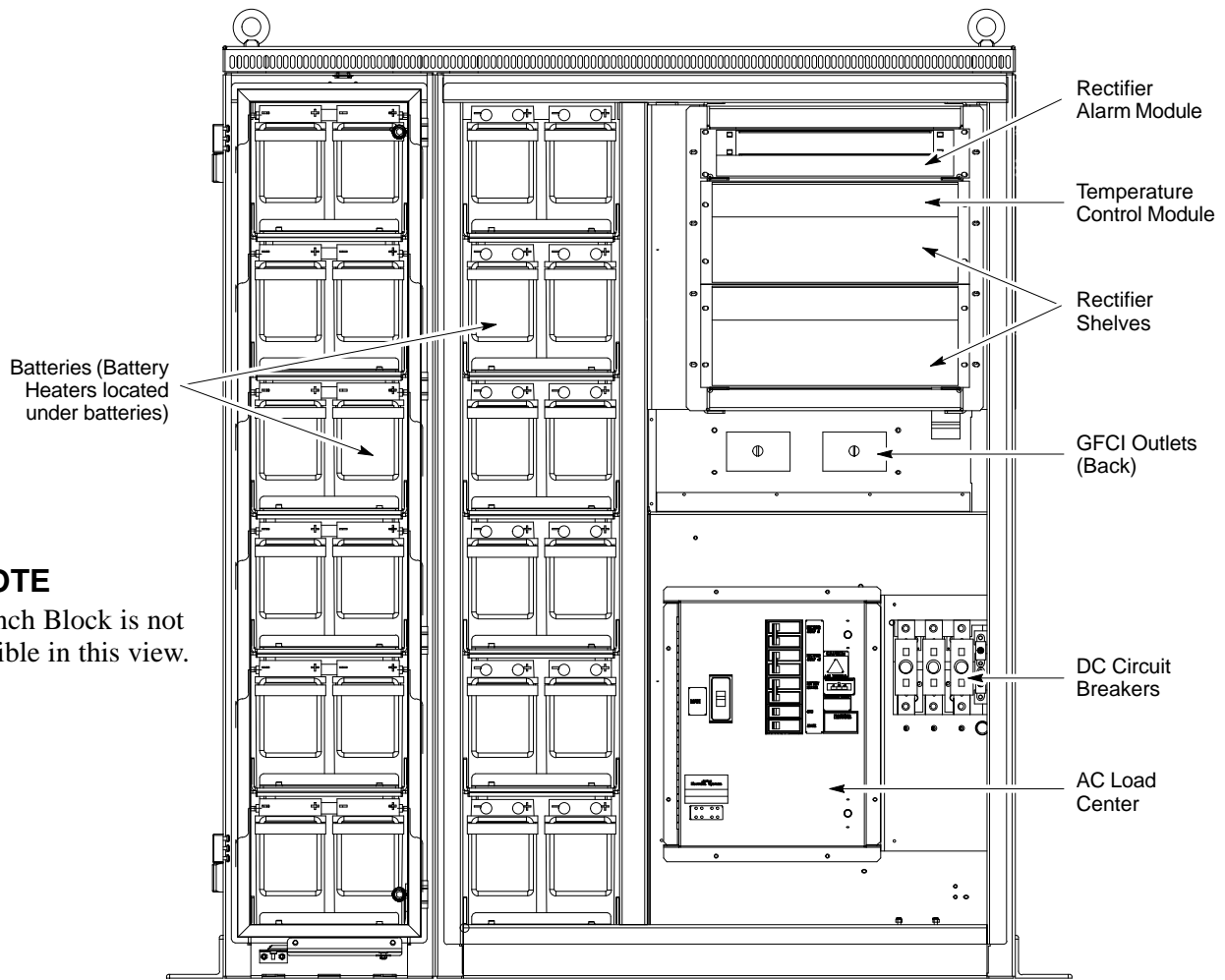

**FRONT VIEW POWER CABINET**

**Batteries**

The batteries provide a +24 Vdc backup to the RF Cabinet should AC Power be lost. The Power Cabinet can accommodate a total of 24 12-V batteries, configured in 12 strings of 2 batteries each. The time duration of backup provided depends on system configuration.

**Battery Heater**

The battery heaters provide heating to the batteries in the Power Cabinet. A separate heater is required for each string of batteries. The heater is a pad the batteries sit on located top of each battery shelf. The number of heaters is dependent on system configuration.