

**Figure H-11:** 3 Sector, 2 Carrier BTS Combiner DRDC/TRDC Cable Connection

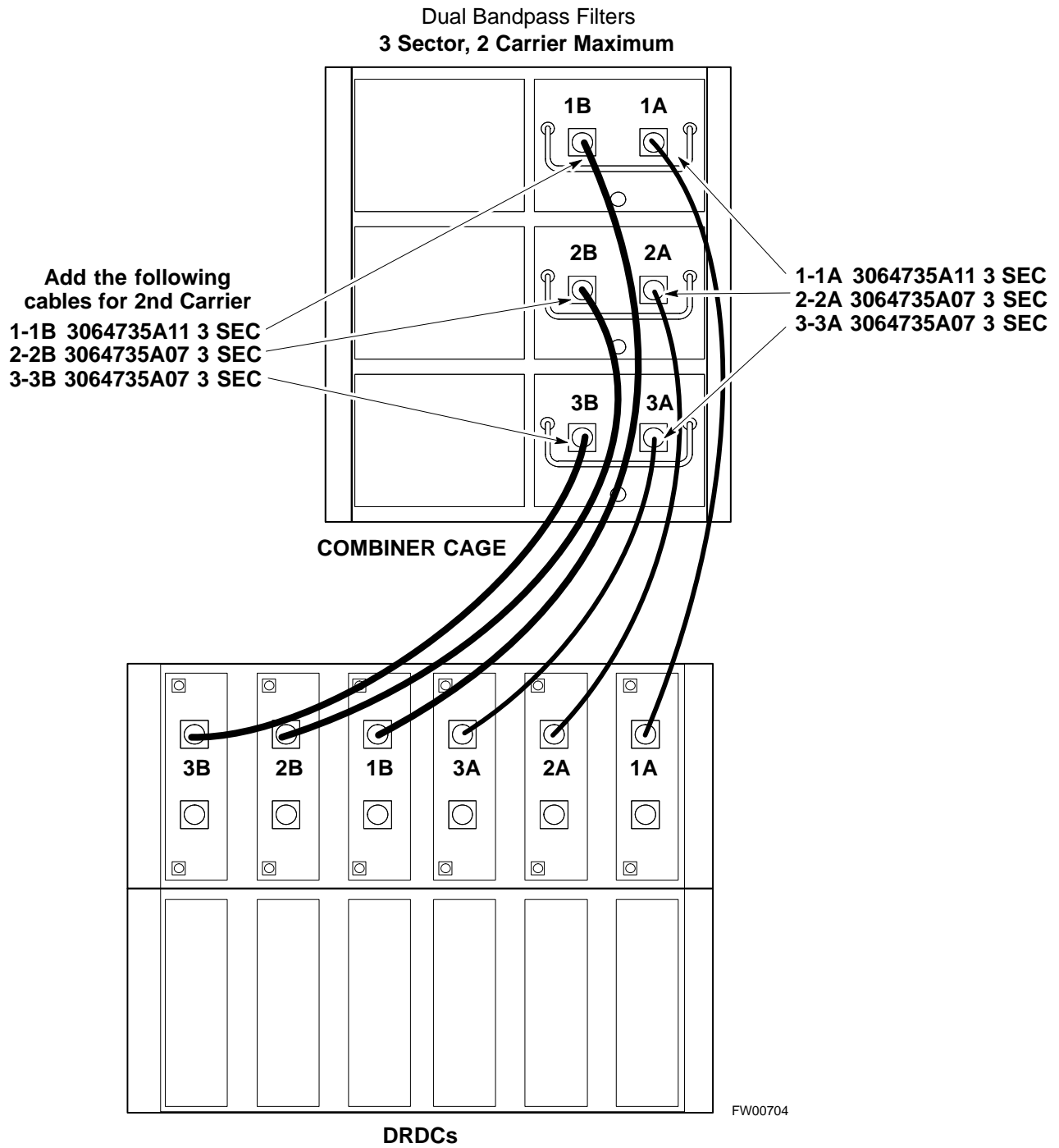
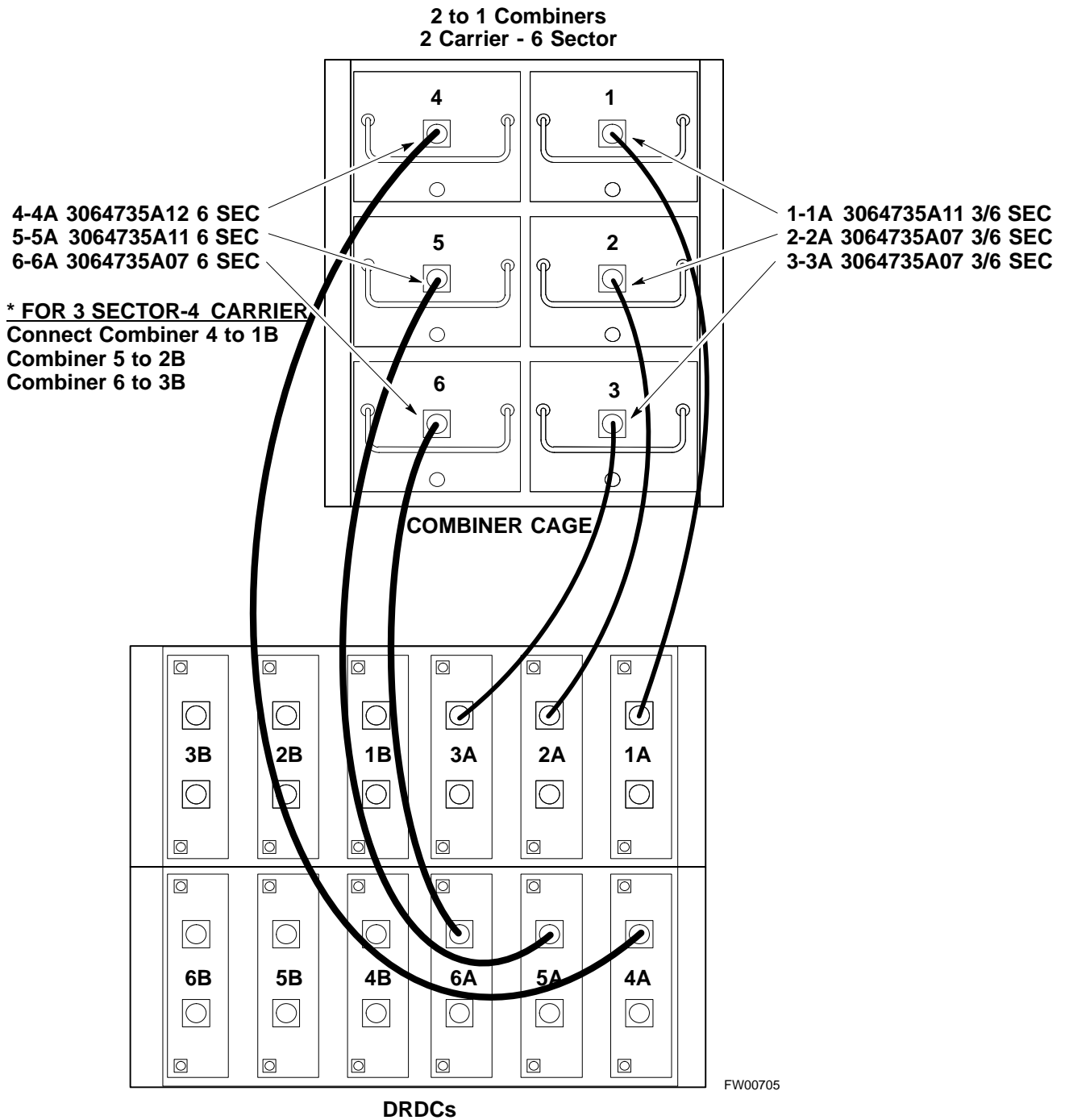

Figure H-12: BTS 2 to 1, 3 or 6 Sector Combiner DRDC/TRDC Cable Connection



H

Figure H-13: BTS Combiner DRDC/TRDC Cable Connection

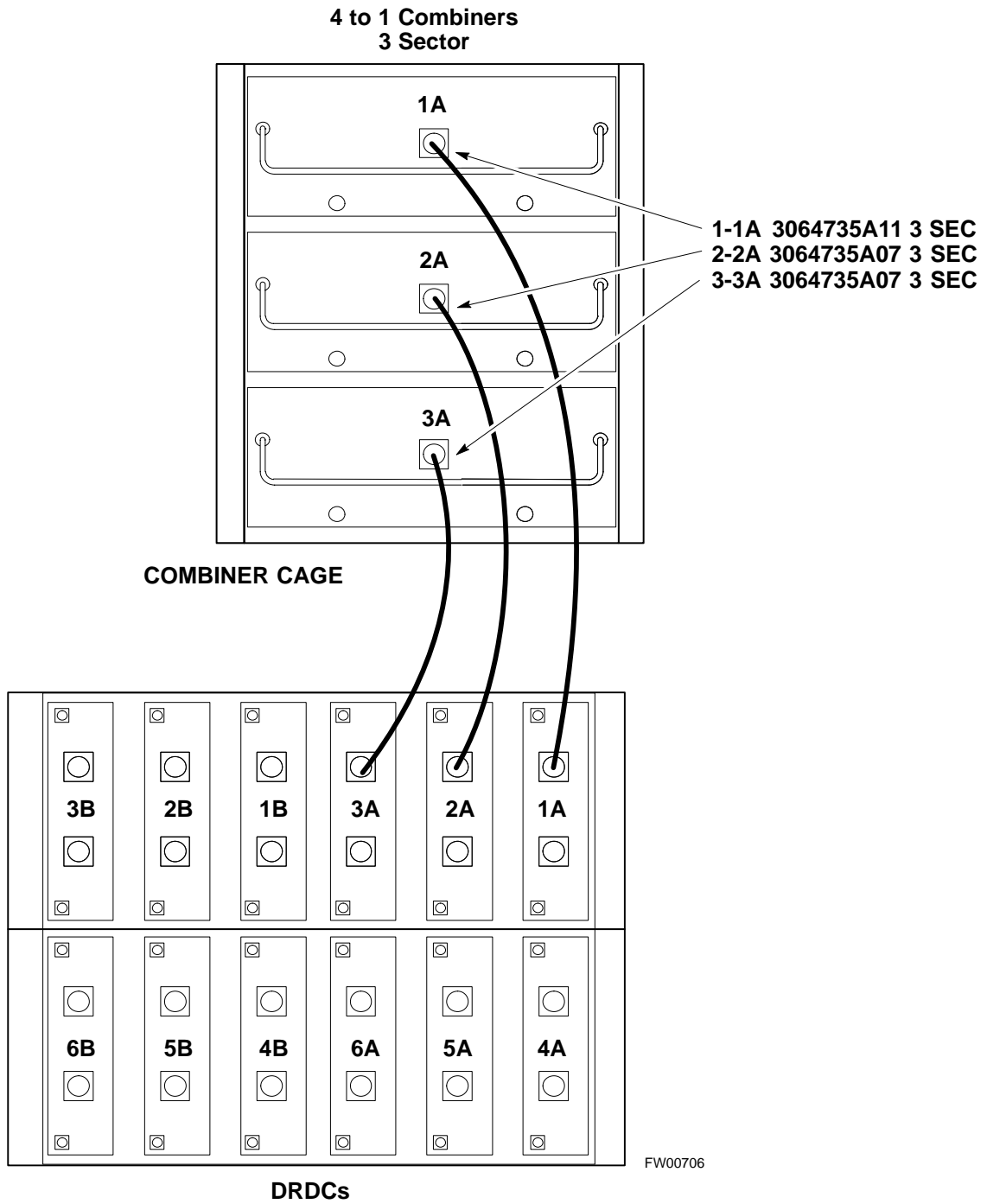
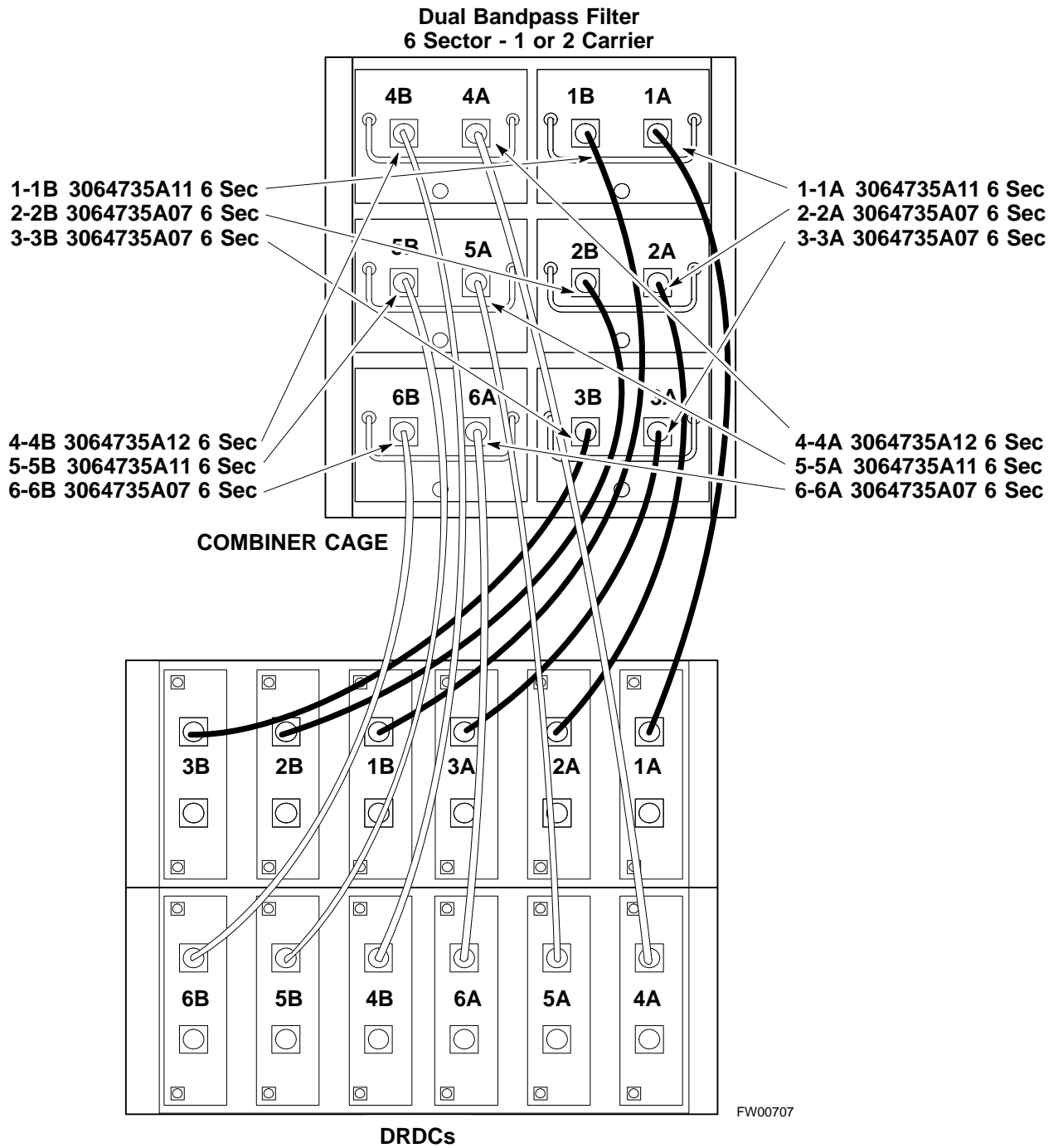

Figure H-14: SC 4812ET BTS Combiner DRDC/TRDC Cable Connection



H

## MPC Functional Description

The MPC card provides (see Figure H-15) low-noise amplification for all RX path signals. The low noise, high gain design improves frame RX sensitivity and overcomes the splitting loss in the receive path. DC voltages are monitored on the RF devices and regulators and are used to generate hard and soft alarms. The MPC is not redundant at the card-level, but includes dual-path amplifiers which provide soft-fail redundancy for all sectors.

### MPC to DRDC Cabling

The cables connecting the MPC cards to the DRDCs for a three sector RF cabinet are shown in Figure H-15. A six sector RF cabinet would have six more DRDC's and they would be connected to the front of the MPC cards.

Figure H-15: DRDC To C-CCP Cage MPC Boards Cable Connections

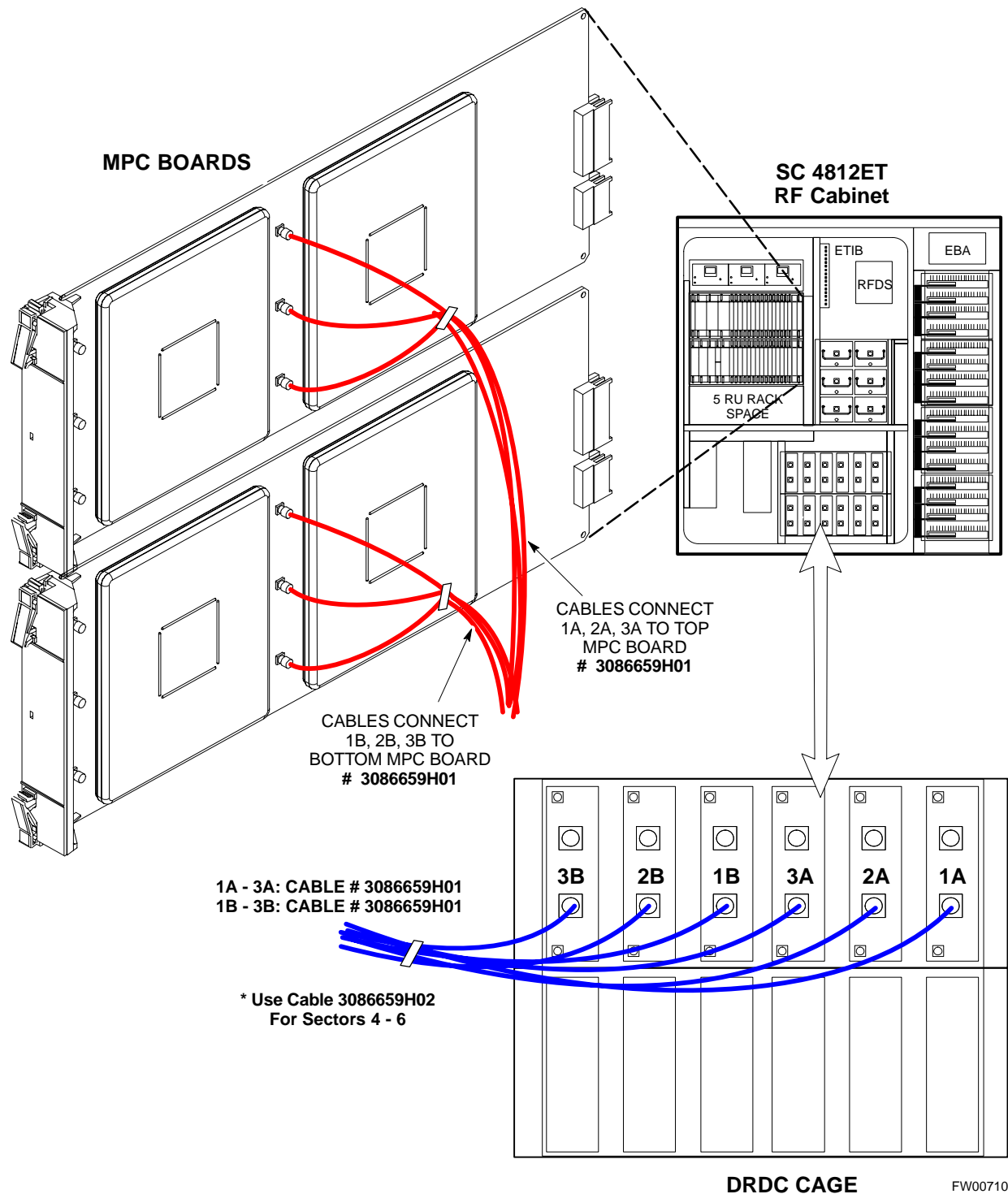

H

## RFDS Cabling Details

Figure H-16 shows the components of the RFDS. Table H-2 depicts the cabling for a 3-Sector Duplexed configuration and Table H-3 depicts the cabling for a 6-Sector Duplexed configuration. Figure H-17 shows the connection of the RFDS to the BTS combiners.

**Figure H-16:** RFDS Component Identification

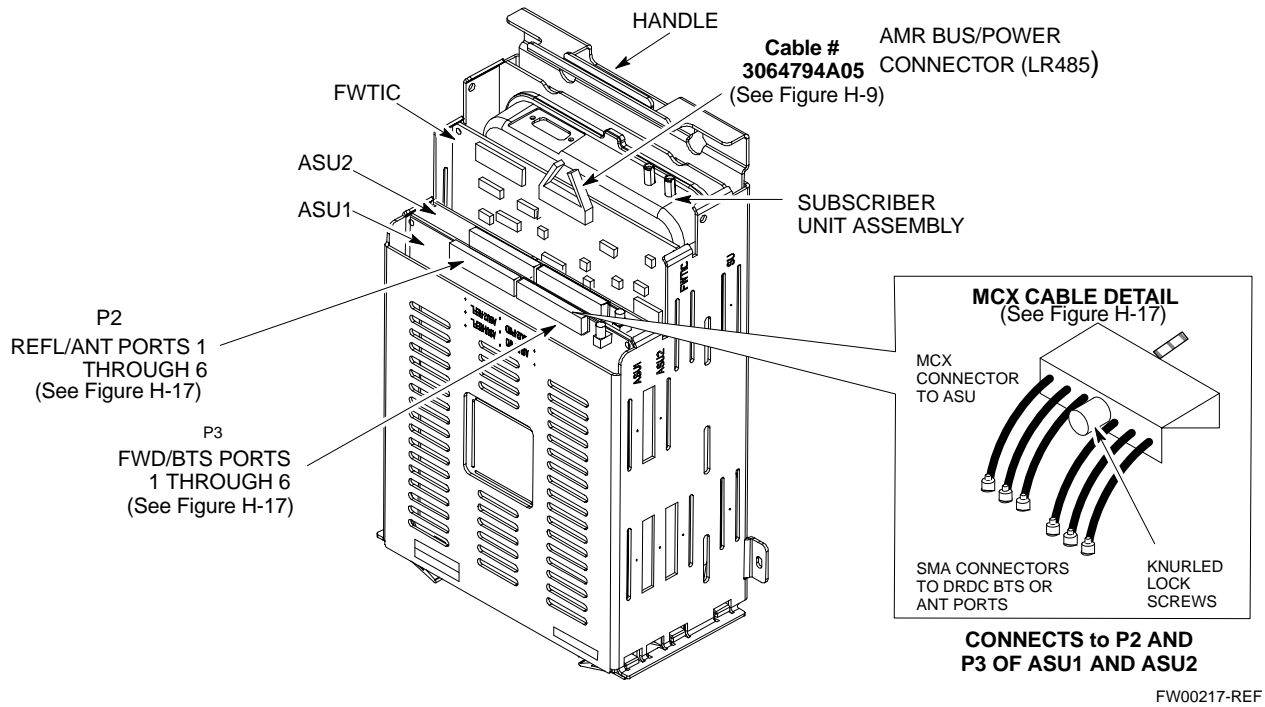

**Table H-2:** SC 4812ET Series 3-Sector Duplexed Directional Coupler to RFDS Cabling Table

DRDC Label	Directional Coupler Port	Cobra RFDS Port
<b>ASU 1 - FWD (six pack MCX)</b>		
1A BTS	Sector 1 Main BTS	ASU1-FWD BTS-1
1B BTS	Sector 1 Diversity BTS	ASU1-FWD BTS-2
2A BTS	Sector 2 Main BTS	ASU1-FWD BTS-3
2B BTS	Sector 2 Diversity BTS	ASU1-FWD BTS-4
3A BTS	Sector 3 Main BTS	ASU1-FWD BTS-5
3B BTS	Sector 3 Diversity BTS	ASU1-FWD BTS-6
<b>ASU 1 - REF (six pack MCX)</b>		
1A ANT	Sector 1 Main ANT	ASU1-REF ANT-1
1B ANT	Sector 1 Diversity ANT	ASU1-REF ANT-2
2A ANT	Sector 2 Main ANT	ASU1-REF ANT-3
2B ANT	Sector 2 Diversity ANT	ASU1-REF ANT-4
3A ANT	Sector 3 Main ANT	ASU1-REF ANT-5
3B ANT	Sector 3 Diversity ANT	ASU1-REF ANT-6

H

**Table H-3: SC 4812ET Series 6-Sector Duplexed Directional Coupler to RFDS Cabling Table**

<b>DRDC Label</b>	<b>Directional Coupler Port</b>	<b>Cobra RFDS Port</b>
<b>ASU 1 - FWD (six pack MCX)</b>		
1A BTS	Sector 1 Main BTS	ASU1-FWD BTS-1
1B BTS	Sector 1 Diversity BTS	ASU1-FWD BTS-2
2A BTS	Sector 2 Main BTS	ASU1-FWD BTS-3
2B BTS	Sector 2 Diversity BTS	ASU1-FWD BTS-4
3A BTS	Sector 3 Main BTS	ASU1-FWD BTS-5
3B BTS	Sector 3 Diversity BTS	ASU1-FWD BTS-6
<b>ASU 2 - FWD (six pack MCX)</b>		
4A BTS	Sector 4 Main BTS	ASU2-FWD BTS-1
4B BTS	Sector 4 Diversity BTS	ASU2-FWD BTS-2
5A BTS	Sector 5 Main BTS	ASU2-FWD BTS-3
5B BTS	Sector 5 Diversity BTS	ASU2-FWD BTS-4
6A BTS	Sector 6 Main BTS	ASU2-FWD BTS-5
6B BTS	Sector 6 Diversity BTS	ASU2-FWD BTS-6
<b>ASU 1 - REF (six pack MCX)</b>		
1A ANT	Sector 1 Main ANT	ASU1-REF ANT-1
1B ANT	Sector 1 Diversity ANT	ASU1-REF ANT-2
2A ANT	Sector 2 Main ANT	ASU1-REF ANT-3
2B ANT	Sector 2 Diversity ANT	ASU1-REF ANT-4
3A ANT	Sector 3 Main ANT	ASU1-REF ANT-5
3B ANT	Sector 3 Diversity ANT	ASU1-REF ANT-6
<b>ASU 2 - REF (six pack MCX)</b>		
4A ANT	Sector 4 Main ANT	ASU2-REF ANT-1
4B ANT	Sector 4 Diversity ANT	ASU2-REF ANT-2
5A ANT	Sector 5 Main ANT	ASU2-REF ANT-3
5B ANT	Sector 5 Diversity ANT	ASU2-REF ANT-4
6A ANT	Sector 6 Main ANT	ASU2-REF ANT-5
6B ANT	Sector 6 Diversity ANT	ASU2-REF ANT-6





**Figure H-17:** SC 4812ET BTS Combiner DRDC/TRDC RFDS Cable Connection

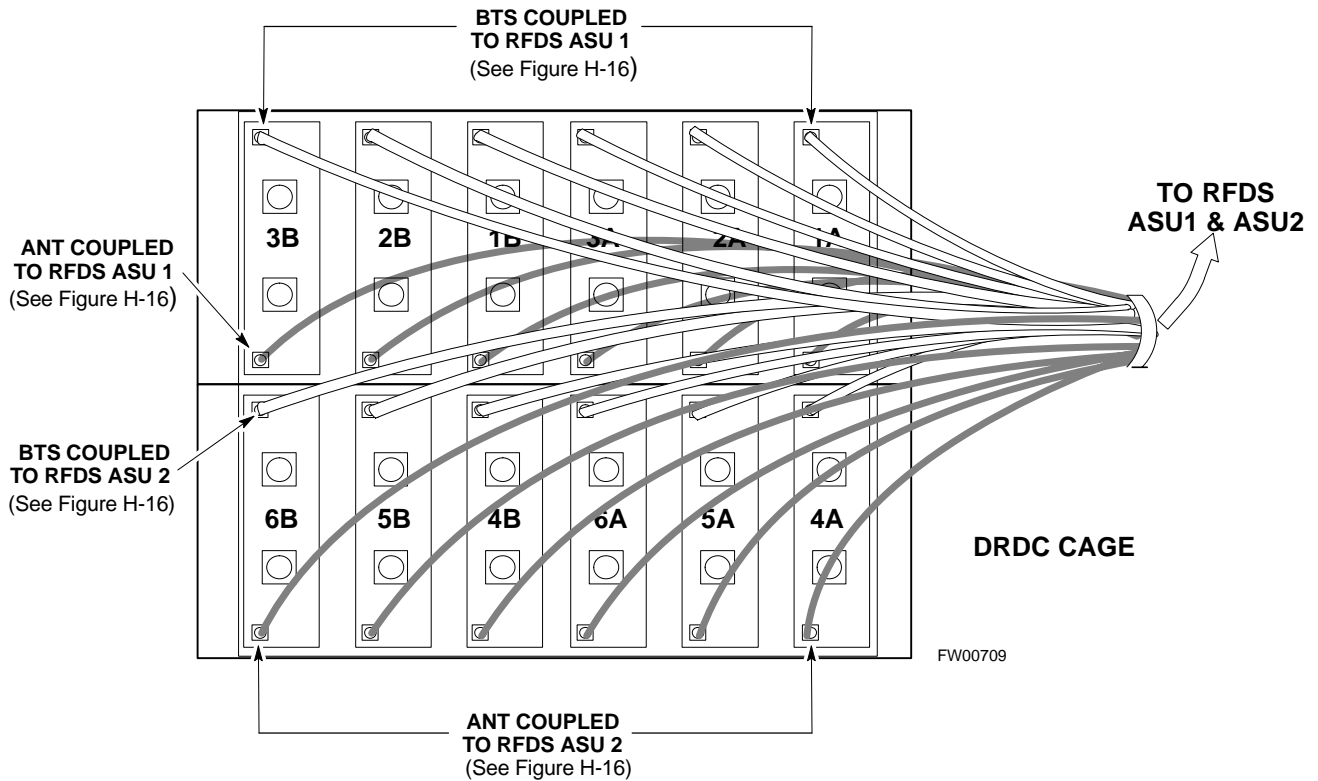

## 50 Pair Punchblock

The 50 pair punchblock is the main interface point for RGPS, span lines, customer I/O, Power Cabinet alarm lines, and the modem. The punchblock provides primary protection for all lines. Refer to Figure H-18 and Table H-4 for punchblock pin-out.

<b>CAUTION</b>	<p>SC4812ET Span Line Labeling for Span B and Span C is swapped</p> <ul style="list-style-type: none"> <li>- On the SC4812ET's, the span cable internal to the base station that connects the 50 pin header on the I/O plate to the CSU has Span B and Span C (RJ-45) connectors mis-labeled.</li> <li>- CFE will punch down the span on the 50 pair bunchblock as per Motorola documentation and punchdown chart. When connecting the span input to the CSU re-label "Span B" cable to "Span C" cable to "Span B". Connect to CSU as per documentation</li> <li>- Note: The labeling issue on the cable from the I/O plate to the CSU Part Number 3086601H01 Rev C shall be corrected on revision "D" to address this issue. The cut over date to Rev. D will be approximately January 30, 2001.</li> </ul>
----------------	--



**CAUTION**

A wiring discrepancy exists between the manuals and the frame for remote GPS.

- The TX and RX are reversed in the ETIB, leading to inoperability of the RGPS. The RGPS will not work in either a single standalone or multiple frame configuration.
- Swap the White and White/Bk wires to punch pins 44T and 44R. The Green and Green/Bk go to 45T and 45R. This will correct non-expansion configurations.
- Single frame and expansion BTSs without RGPS can use this workaround as a permanent solution.
- For expansion with RGPS required a new cable (P/N 3086433H10 ) will correct the problem.



Figure H-18: 50 Pair Punchblock

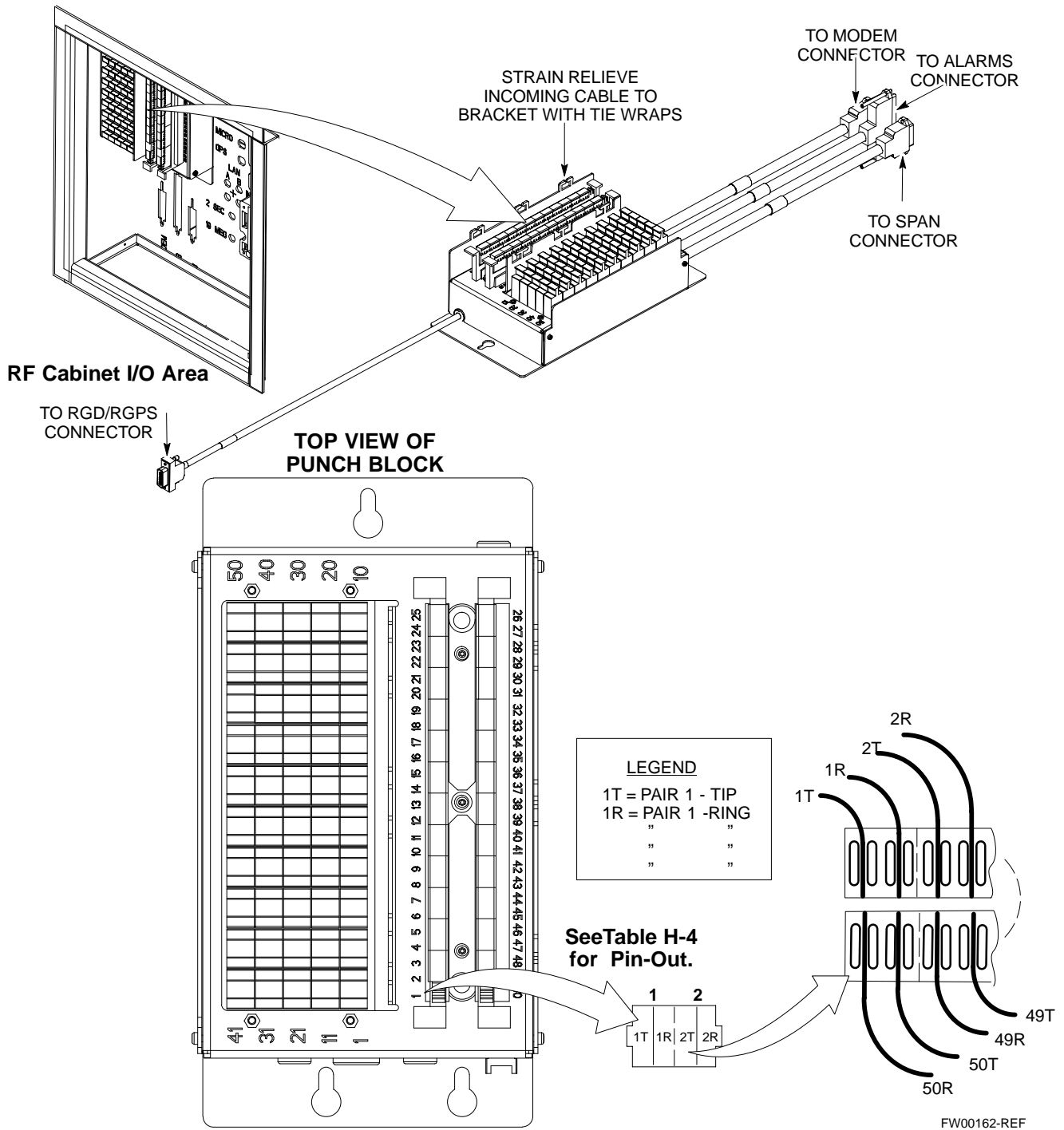

## Alarm and Span Line Cable Pin/Signal Information

Table H-4 lists the complete pin/signal identification for the 50-pin punch block.

<b>Table H-4: Pin-Out for 50-Pair Punchblock</b>				
<b>Punchblock Cable Connector</b>	<b>Function</b>	<b>Signal Name</b>	<b>Punch Pin</b>	<b>Ext. Cable Wire Color</b>
ALARM	Power Cabinet	Power Cab Control - NC	1T	Blue
		Power Cab Control - NO	1R	Blk/Blue
		Power Cab Control-Com	2T	Yellow
		Reserved	2R	N/C
		Rectifier Fail	3T	Blk/Yellow
		AC Fail	3R	Green
		Power Cab Exchanger Fail	4T	Blk/Grn
		Power Cab Door Alarm	4R	White
		Power Cab Major Alarm	5T	Blk/White
		Battery Over Temp	5R	Red
		Power Cab Minor Alarm	6T	Blk/Red
		Reticifier Over Temp	6R	Brown
		Power Cab Alarm Rtn	7T	Blk/Brn
	HSO/LFR Extension	LFR_HSO_GND	7R	
		EXT_1PPS_POS	8T	
		EXT_1PPS_NEG	8R	
	LFR Antenna	CAL_+	9T	
		CAB_-	9R	
		LORAN_+	10T	
		LORAN_-	10R	
	Pilot Beacon	Pilot Beacon Alarm - Minor	11T	
		Pilot Beacon Alarm - Rtn	11R	
		Pilot Beacon Alarm - Major	12T	
		Pilot Beacon Control-NO	12R	
		Pilot Beacon Control - COM	13T	
		Pilot Beacon Control - NC	13R	

... continued on next page



**Table H-4: Pin-Out for 50-Pair Punchblock**

Punchblock Cable Connector	Function	Signal Name	Punch Pin	Ext. Cable Wire Color
ALARM	Customer Outputs	Customer Outputs 1 - NO	14T	
		Customer Outputs 1 - COM	14R	
		Customer Outputs 1 - NO	14T	
		Customer Outputs 1 - COM	14R	
		Customer Outputs 1 - NC	15T	
		Customer Outputs 2 - NO	15R	
		Customer Outputs 2 - COM	16T	
		Customer Outputs 2 - NC	16R	
		Customer Outputs 3 - NO	17T	
		Customer Outputs 3 - COM	17R	
		Customer Outputs 3 - NC	18T	
		Customer Outputs 4 - NO	18R	
		Customer Outputs 4-COM	19T	
		Customer Outputs 4 - NC	19R	
ALARM	Customer Inputs	Customer Inputs 1	20T	
		Cust_Rtn_A_1	20R	
		Customer Inputs 2	21T	
		Cust_Rtn_A_2	21R	
		Customer Inputs 3	22T	
		Cust_Rtn_A_3	22R	
		Customer Inputs 4	23T	
		Cust_Rtn_A_4	23R	
		Customer Inputs 5	24T	
		Cust_Rtn_A_5	24R	
		Customer Inputs 6	25T	
		Cust_Rtn_A_6	25R	
		Customer Inputs 7	26T	
		Cust_Rtn_A_7	26R	
		Customer Inputs 8	27T	
		Cust_Rtn_A_8	27R	
		Customer Inputs 9	28T	
		Cust_Rtn_A_9	28R	
Customer Inputs 10	29T			
Cust_Rtn_A_10	29R			

... continued on next page



**Table H-4: Pin-Out for 50-Pair Punchblock**

Punchblock Cable Connector	Function	Signal Name	Punch Pin	Ext. Cable Wire Color
SPAN I/O	Span 1	RCV_TIP_A	30T	
		RCV_RING_A	30R	
		XMIT_TIP_A	31T	
		XMIT_RING_A	31R	
	Span 2	RCV_TIP_B	32T	
		RCV_RING_B	32R	
		XMIT_TIP_B	33T	
		XMIT_RING_B	33R	
	Span 3	RCV_TIP_C (Note)	34T	
		RCV_RING_C (Note)	34R	
		XMIT_TIP_C (Note)	35T	
		XMIT_RING_C(Note)	35R	
	Span 4	RCV_TIP_D (Note)	36T	
		RCV_RING_D (Note)	36R	
		XMIT_TIP_D (Note)	37T	
		XMIT_RING_D(Note)	37R	
	Span 5	RCV_TIP_E (Note)	38T	
		RCV_RING_E (Note)	38R	
		XMIT_TIP_E (Note)	39T	
		XMIT_RING_E(Note)	39R	
	Span 6	RCV_TIP_F (Note)	40T	
		RCV_RING_F (Note)	40R	
		XMIT_TIP_F (Note)	41T	
		XMIT_RING_F(Note)	41R	
		<b>NOTE</b> Span 3 through 6 are spares for expansion purposes		

... continued on next page



Table H-4: Pin-Out for 50-Pair Punchblock

Punchblock Cable Connector	Function	Signal Name	Punch Pin	Ext. Cable Wire Color
RGD/RGPS	<b>For frame without RGD Expansion Punchblock</b> Single Frame BTS;RGPS Head Connection <b>OR</b> Multiple Frame BTS; RGD Connection at RGPS Secondary Frame	GPS_Power_A	42T	Yellow
		GPS_Power_A_Return	42R	Yellow/Black
		GPS_Power_B	43T	Blue
		GPS_Power_B_Return	43R	Blue/Black
		GPS_TXD+	44T	White
		GPS_TXD-	44R	White/Black
		GPS_RXD+	45T	Green
		GPS_RXD-	45R	Green/Black
		Signal Ground (TDR+)	46T	Red
		Signal Ground (TDR-)	46R	Red/Black
		GPS_1PPS+	47T	Brown
		GPS_1PPS-	47R	Brown/Black
RGD/RGPS	<b>For frame with RGD Expansion Punchblock</b> <b>OR</b> Multiple Frame BTS; RGPS Head Connection at RGPS Primary Frame	GPS_Power_A	42T	Yellow
		GPS_Power_A_Return	42R	Yellow/Black
		GPS_Power_B	43T	Blue
		GPS_Power_B_Return	43R	Blue/Black
		GPS_TXD+	44T	White
		GPS_TXD-	44R	White/Black
		GPS_RXD+	45T	Green
		GPS_RXD-	45R	Green/Black
		Signal Ground (TDR+)	46T	Red
		Master Frame (TDR-)	46R	Red/Black
		GPS_1PPS+	47T	Brown
		GPS_1PPS-	47R	Brown/Black
MODEM		Reserved	48T	
		Reserved	48R	
RGD/RGPS		Chassis Ground	49T	N/A
None		No Connection	49R	None
ALARM		Reserved	50T	None
		Reserved	50R	None

# RF Cabinet Parts Locator

Figure H-19 illustrates the location of door switch interlocks, DC Power distribution and the EBA blower assembly.

**Figure H-19:** SC 4812ET RF Cabinet Parts Locator

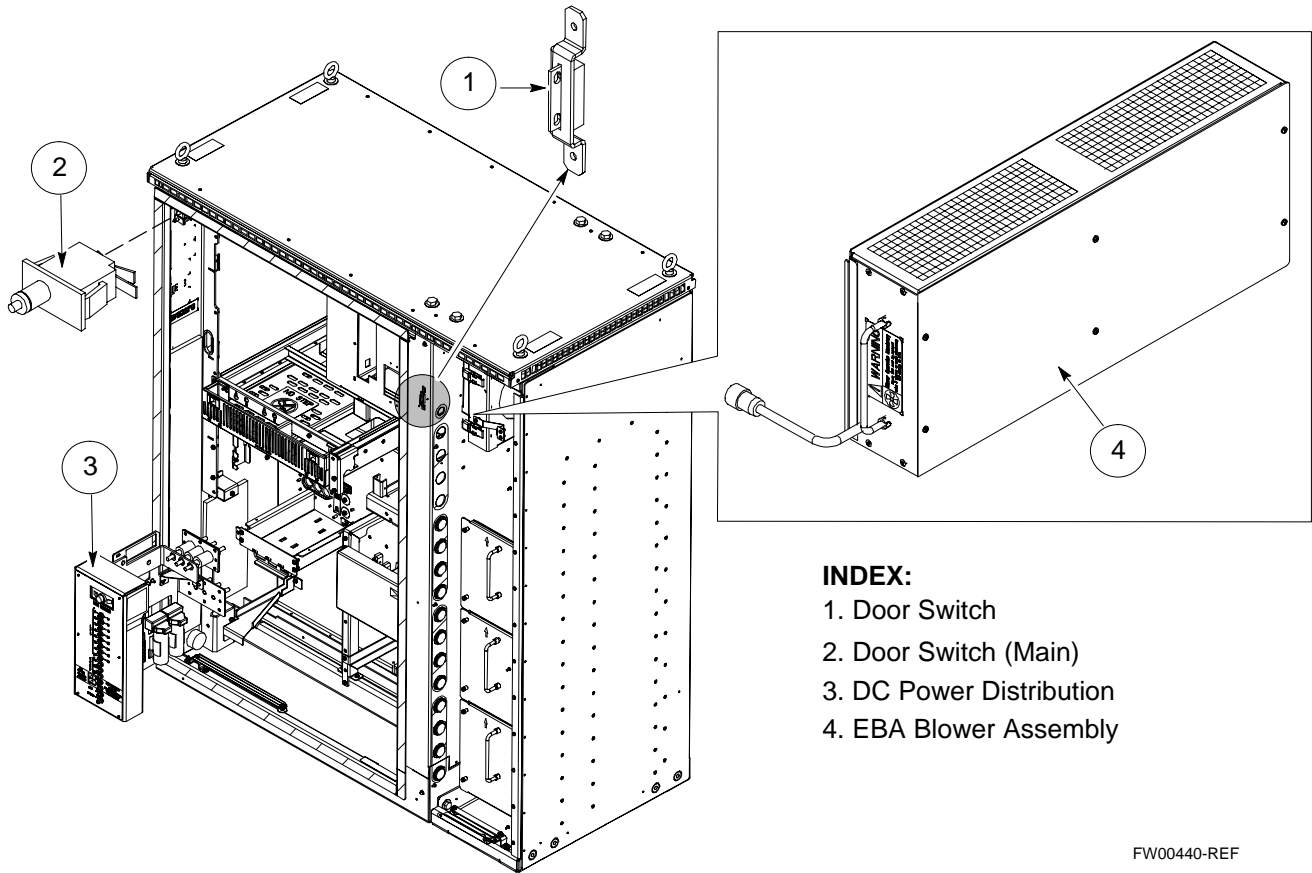

- INDEX:**
- 1. Door Switch
  - 2. Door Switch (Main)
  - 3. DC Power Distribution
  - 4. EBA Blower Assembly

FW00440-REF





*Appendix I*

# **GPIB Addressing**



# GPIB

## GPIB Introduction

Use the procedures in this appendix to verify and/or change the GPIB addresses of the applicable test equipment.

### HP437 Power Meter GPIB Address

Follow the steps in Table I-1 to verify and, if necessary, change the HP437 GPIB address.

**NOTE** This procedure assumes that the test equipment is set up and ready for testing.

Table I-1: Verify and/or Change HP437 Power Meter GPIB Address	
Step	Action
1	Press <b>Shift</b> and <b>PRESET</b> (see Figure I-1).
2	Use the <b>▲</b> arrow key to navigate to HP-IB ADRS and press <b>ENTER</b> . The HP-IB address is displayed.  <b>NOTE</b> HP-IB is the same as GPIB.
3	If the current GPIB address is not set to <b>13</b> , perform the following to change it: - Use the <b>▲ ▼</b> arrow keys to change the HP-IB ADRS to <b>13</b> . - Press <b>ENTER</b> to set the address.
4	Press <b>Shift</b> and <b>ENTER</b> to return to a standard configuration.

**Figure I-1:** HP437 Power Meter

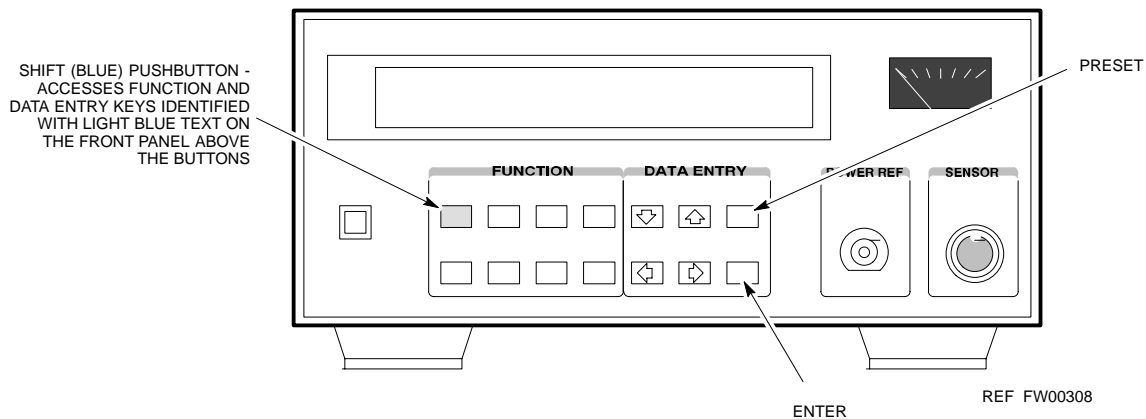

## Gigatronics 8541C Power Meter GPIB Address

Follow the steps in Table I-2 to verify and, if necessary, change the Gigatronics 8541C power meter GPIB address.

**NOTE** This procedure assumes that the test equipment is set up and ready for testing.

Table I-2: Verify and/or Change Gigatronics 8541C Power Meter GPIB Address	
Step	Action
	<p><b>! CAUTION</b></p> <p>Do not connect/disconnect the power meter sensor cable with AC power applied to the meter. Disconnection could result in destruction of the sensing element or miscalibration.</p>
1	Press <b>MENU</b> (see Figure I-2).
2	Use the <b>▼</b> arrow key to select <b>CONFIG MENU</b> and press <b>ENTER</b> .
3	Use the <b>▼</b> arrow key to select <b>GPIB</b> and press <b>ENTER</b> . The current <b>Mode</b> and <b>GPIB Address</b> are displayed.
4	If the <b>Mode</b> is not set to <b>8541C</b> , perform the following to change it: Use the <b>◀▶</b> arrow keys as required to select <b>MODE</b> . Use the <b>▼▲</b> arrow keys as required to set <b>MODE</b> to <b>8541C</b> .
5	If the GPIB address is not set to <b>13</b> , perform the following to change it: Use the <b>▶</b> arrow key to select <b>ADDRESS</b> . Use the <b>▼▲</b> arrow keys as required to set the GPIB address to <b>13</b> .
6	Press <b>ENTER</b> to return to normal operation.

Figure I-2: Gigatronics 8541C Power Meter Detail

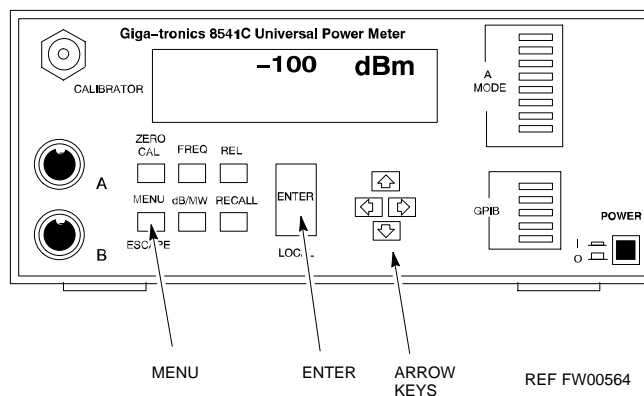

## Motorola CyberTest GPIB Address

Follow the steps in Table I-3 to verify and, if necessary, change the GPIB address on the Motorola CyberTest. Changing the GPIB address requires the following items:

- Motorola CyberTest communications analyzer
- Computer running Windows 3.1/Windows 95
- Motorola CyberTAME software program “TAME”
- Parallel printer port cable (shipped with CyberTest)

**NOTE** This procedure assumes that the test equipment is set up and ready for testing.

**Table I-3:** Verify and/or Change Motorola CyberTest GPIB Address

Step	Action
1	On the LMF desktop, locate the CyberTAME icon. Double click on the icon to run the CyberTAME application.
2	In the CyberTAME window taskbar, under <b>Special</b> , select <b>IEEE.488.2</b> .
3	CyberTAME software will query the CyberTest Analyzer for its current GPIB address. It then will open the IEEE 488.2 dialog box. If the current GPIB address is not 18, perform the following procedure to change it: <ul style="list-style-type: none"> <li>- Use the up or down increment arrows, or double-click in the field and type the number.</li> <li>- Click on the <b>OK</b> button.</li> </ul> The new address will be written to the CyberTest via the parallel port and saved.
	<p><b>NOTE</b></p> <p>Verify that the address has been set by repeating steps 2 and 3. The new address should now appear in the IEEE 488.2 dialog box Address field.</p>

## HP8935 Test Set GPIB Address

Follow the procedure in Table I-4 to verify and, if necessary, change the HP8935 GPIB address.

**NOTE** This procedure assumes that the test equipment is set up and ready for testing.

**Table I-4:** Verify and/or Change HP8935 GPIB Address

Step	Action
	<p><b>* IMPORTANT</b></p> <p>The HP I/O configuration <b>MUST</b> be set to <b>Talk &amp; Listen</b>, or NO device on the GPIB bus will be accessible. (Consult test equipment OEM documentation for additional information as required.)</p>
1	<p>To verify that the GPIB addresses are set correctly, press <b>Shift</b> and <b>LOCAL</b> on the HP8935 (see Figure I-3). The current HP-IB address is displayed at the top of the screen.</p> <p><b>NOTE</b></p> <p>HP-IB is the same as GPIB.</p>

**Table I-4: Verify and/or Change HP8935 GPIB Address**

Step	Action
2	If the current GPIB address is not set to <b>18</b> , perform the following to change it: <ul style="list-style-type: none"> <li>- Press <b>Shift</b> and <b>Inst Config</b>.</li> <li>- Turn the <b>Cursor Control</b> knob to move the cursor to the <b>HP-IB Adrs</b> field.</li> <li>- Press the <b>Cursor Control</b> knob to select the field.</li> <li>- Turn the <b>Cursor Control</b> knob as required to change the address to 18.</li> <li>- Press the <b>Cursor Control</b> knob to set the address.</li> </ul>
3	<ul style="list-style-type: none"> <li>• Press <b>Preset</b> to return to normal operation.</li> </ul>

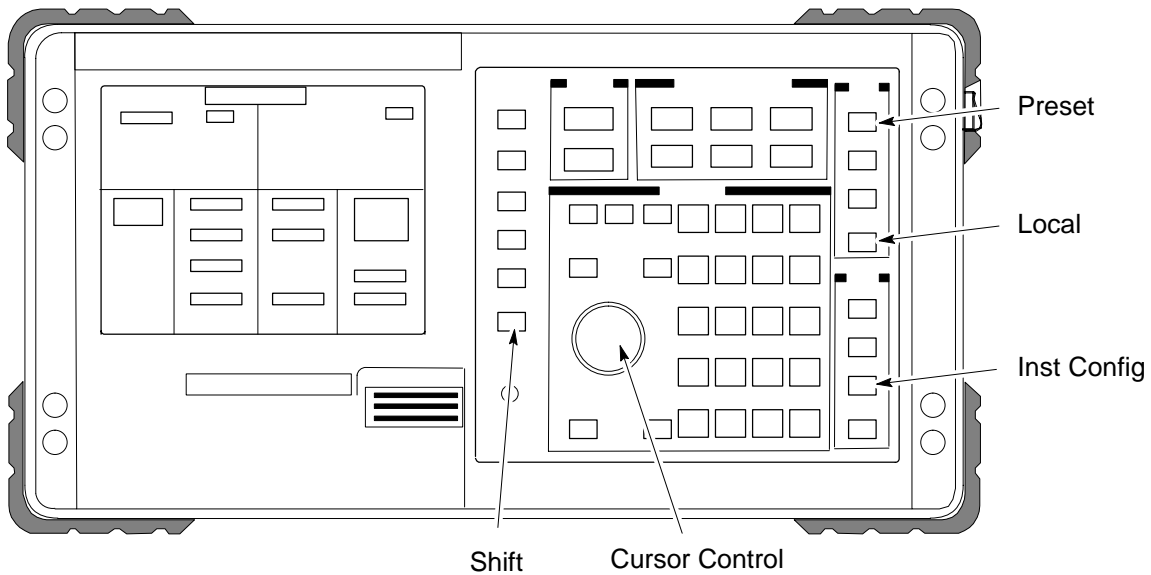
**Figure I-3: HP8935 Test Set**

FW00885

## Setting HP8921A and HP83236A/B GPIB Address

Follow the procedure in Table I-5 to verify and, if necessary, change the HP8921A HP83236A GPIB addresses.

**NOTE** This procedure assumes that the test equipment is set up and ready for testing.

**Table I-5:** Verify and/or Change HP8921A and HP83236A GPIB Addresses

Step	Action
1	<p>To verify that the GPIB addresses are set correctly, press <b>Shift</b> and <b>LOCAL</b> on the HP8921A (see Figure I-4). The current HP-IB address is displayed at the top of the screen.</p> <p><b>NOTE</b> HP-IB is the same as GPIB.</p>
2	<p>If the current HP-IB address is not set to <b>18</b>, perform the following to change it:</p> <ul style="list-style-type: none"> <li>- Turn the <b>Cursor Control</b> knob to move the cursor to <b>More</b> and press the knob to select the field.</li> <li>- Turn the <b>Cursor Control</b> knob to move the cursor to <b>I/O Config</b> and press the knob to select the field.</li> <li>- Turn the <b>Cursor Control</b> knob to move the cursor to <b>Adrs</b> and press the knob to select the field.</li> <li>- Turn the <b>Cursor Control</b> knob to change the HP-IB address to 18 and press the knob to set the address.</li> <li>- Press <b>Shift</b> and <b>Preset</b> to return to normal operation.</li> </ul>
3	<p>To set the HP83236A (or B) PCS Interface GPIB address=<b>19</b>, set the dip switches as follows:</p> <ul style="list-style-type: none"> <li>- A1=1, A2=1, A3=0, A4=0, A5=1, HP-IB/Ser = 1</li> </ul>



**Figure I-4:** HP8921A and HP83236A/B

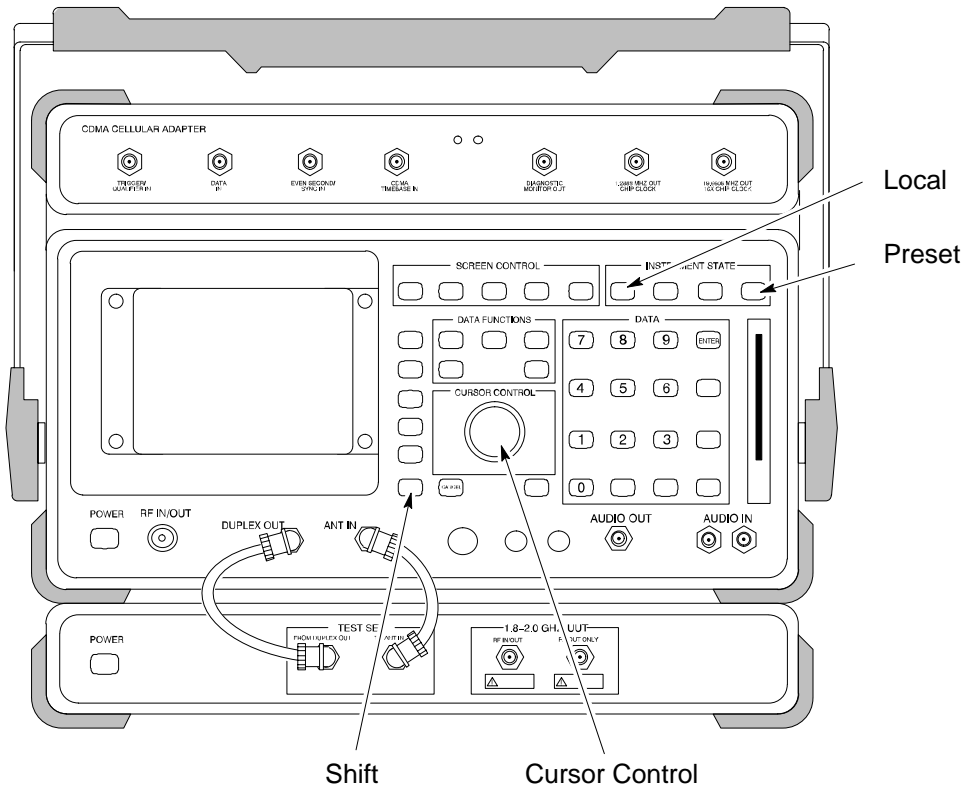

### Advantest R3465 GPIB Address

Table I-6 describes the steps to verify and, if necessary, change the GPIB address for the Advantest R3465.

**NOTE** This procedure assumes that the test equipment is set up and ready for testing.

<b>Table I-6: Verify and/or Change Advantest R3465 GPIB Address</b>	
<b>Step</b>	<b>Action</b>
1	To verify that the GPIB address is set correctly, perform the following procedure: <ul style="list-style-type: none"> <li>- Press <b>SHIFT</b> then <b>PRESET</b> (see Figure I-5).</li> <li>- Press <b>LCL</b>.</li> <li>- Press the <b>GPIB and Others CRT</b> menu key to view the current address.</li> </ul>
2	If the current GPIB address is not set to <b>18</b> , perform the following to change it: <ul style="list-style-type: none"> <li>- Turn the vernier knob as required to select <b>18</b>.</li> <li>- Press the vernier knob to set the address.</li> </ul>
3	To return to normal operation, press <b>Shift</b> and <b>Preset</b> .

Figure I-5: R3465 Communications Test Set

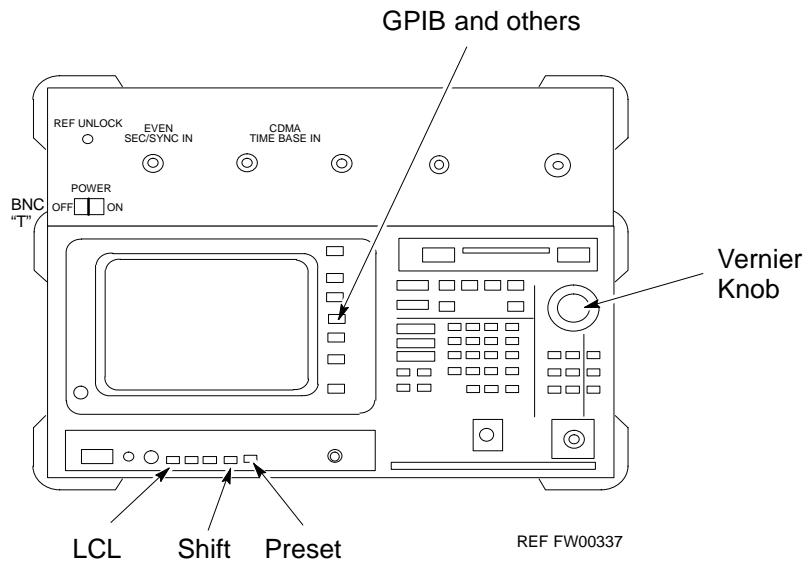

### RS232 GPIB Interface Box

Ensure that the RS232 GPIB interface box dip switches are set as shown in Figure I-6.

Figure I-6: RS232 GPIB Interface Box

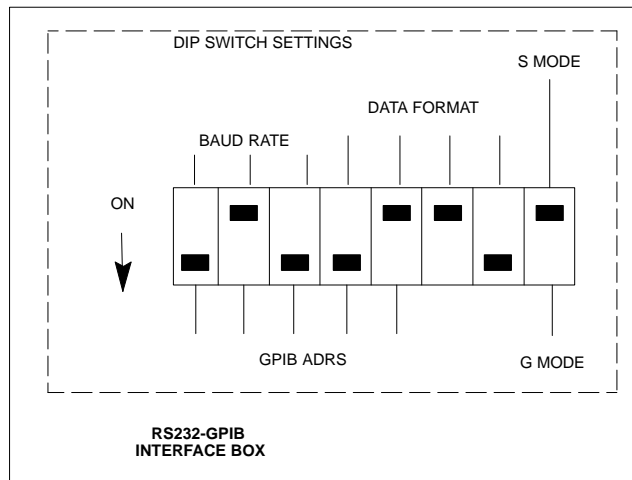

### Advantest R3267 Spectrum Analyzer GPIB Address

Perform the procedure in Table I-7 and refer to Figure I-7 to verify and, if necessary, change the Advantest R3267 spectrum analyzer GPIB address.



**Table I-7: Verify and Change Advantest R3267 GPIB Address**

Step	Action
1	If the <b>REMOTE LED</b> is lighted, press the <b>LCL</b> key. - The LED turns off.
2	Press the <b>CONFIG</b> key. - The <b>CONFIG</b> softkey labels will appear in the softkey label display area of the instrument display. - The current GPIB address will be displayed below the <b>GPIB Address</b> softkey label.
3	If the current GPIB address is not set to <b>18</b> , perform the following to change it:
3a	- Press the <b>GPIB Address</b> softkey. -- A <b>GPIB Address</b> entry window will open in the instrument display showing the current GPIB address.
3b	- Enter <b>18</b> on the keypad in the <b>ENTRY</b> section of the instrument front panel. -- Characters typed on the keypad will replace the address displayed in the <b>GPIB Address</b> entry window.
	<b>NOTE</b> To correct an entry, press the <b>BS</b> (backspace) key at the lower right of the keypad to delete one character at a time.
3c	- Press the <b>ENTR</b> key to the lower right of the keypad to enter the address. -- The <b>GPIB Address</b> entry window closes. -- The new address is displayed in the bottom portion of the <b>GPIB Address</b> softkey label.

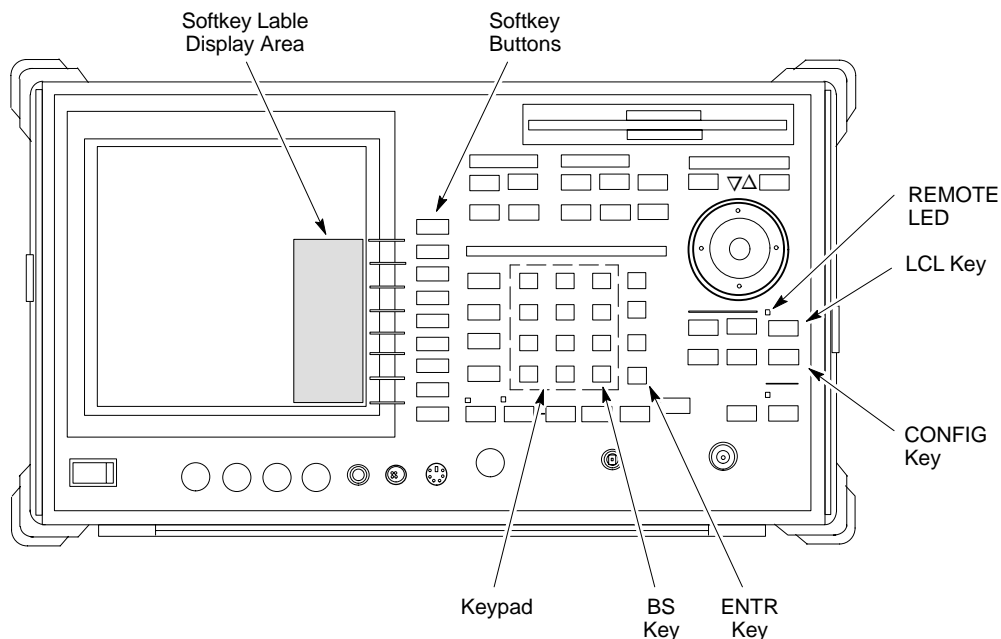
**Figure I-7: Setting Advantest R3267 GPIB Address**

## Advantest R3562 Signal Generator GPIB Address

Set the GP-IB ADDRESS switch on the rear of the Advantest R3562 signal generator to address **1** as shown in Figure I-8.

Figure I-8: Advantest R3562 GPIB Address Switch Setting

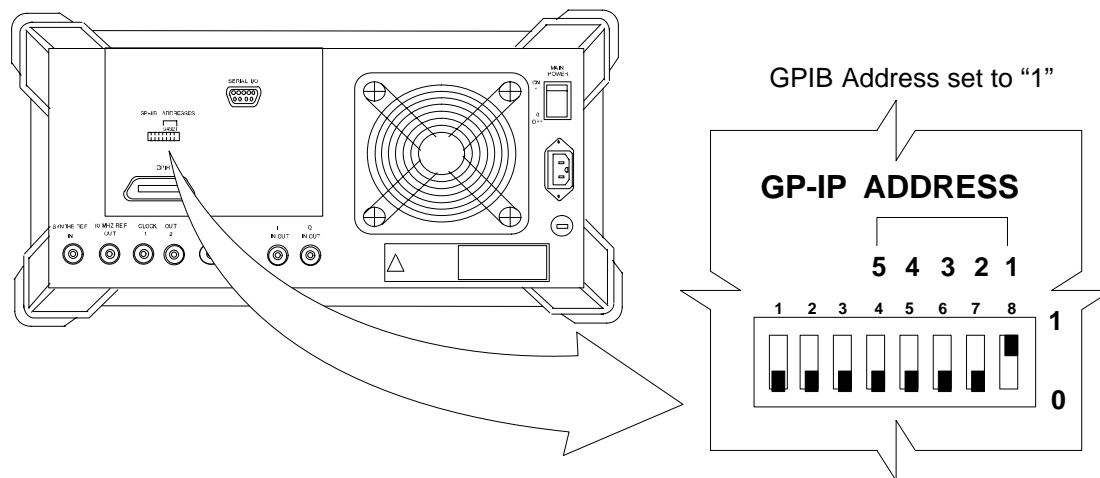

## Agilent E4406A Transmitter Tester GPIB Address

Follow the procedure in Table I-8 and refer to Figure I-9 to verify and, if necessary, change the Agilent E4406A GPIB address.

<b>Table I-8: Verify and Change Agilent E4406A GPIB Address</b>	
<b>Step</b>	<b>Action</b>
1	In the <b>SYSTEM</b> section of the instrument front panel, press the <b>System</b> key. <ul style="list-style-type: none"> <li>- The softkey labels displayed on the right side of the instrument screen will change.</li> </ul>
2	Press the <b>Config I/O</b> softkey button to the right of the instrument screen. <ul style="list-style-type: none"> <li>- The softkey labels will change.</li> <li>- The current instrument GPIB address will be displayed below the <b>GPIB Address</b> softkey label.</li> </ul>
3	If the current GPIB address is not set to <b>18</b> , perform the following to change it:
3a	<ul style="list-style-type: none"> <li>- Press the GPIB Address softkey button.               <ul style="list-style-type: none"> <li>-- In the on-screen Active Function Area, <b>GPIB Address</b> will be displayed followed by the current GPIB address.</li> </ul> </li> </ul>
3b	<ul style="list-style-type: none"> <li>- On the front panel Data Entry keypad, enter the communications system analyzer GPIB address of <b>18</b>.               <ul style="list-style-type: none"> <li>-- The <b>GPIB Address</b> label will change to <b>Enter</b>.</li> <li>-- Digits entered with the keypad will replace the current GPIB address in the display.</li> </ul> </li> </ul> <p><b>NOTE</b> To correct an entry, press the <b>Bk Sp</b> key at the upper right of the keypad to delete one character at a time.</p>
3c	<ul style="list-style-type: none"> <li>- Press the <b>Enter</b> softkey button or the keypad <b>Enter</b> key to set the new GPIB address.               <ul style="list-style-type: none"> <li>-- The <b>Config I/O</b> softkey labels will reappear.</li> <li>-- The new GPIB address will be displayed under the <b>GPIB Address</b> softkey label.</li> </ul> </li> </ul>



**Figure I-9:** Setting Agilent E4406A GPIB Address

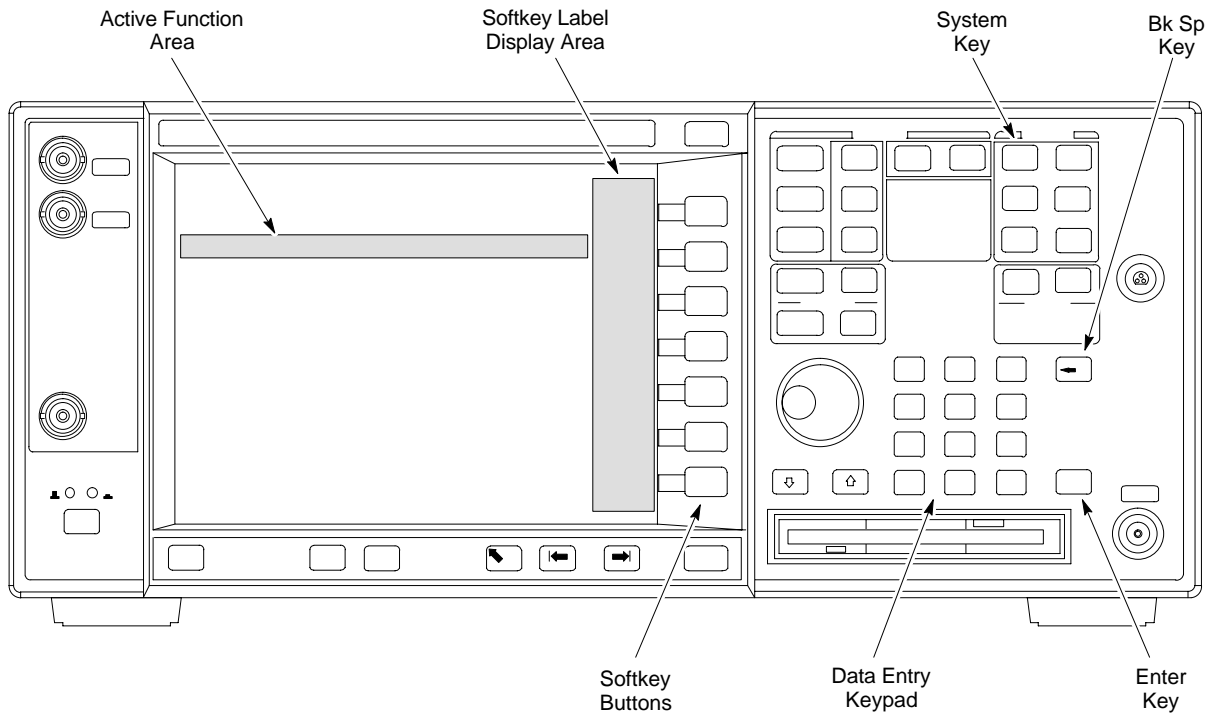

### Agilent E4432B Signal Generator GPIB Address

Follow the procedure in Table I-9 and refer to Figure I-10 to verify and, if necessary, change the Agilent E4432B GPIB address.

**Table I-9:** Verify and Change Agilent E4432B GPIB Address

Step	Action
1	In the <b>MENUS</b> section of the instrument front panel, press the <b>Utility</b> key. - The softkey labels displayed on the right side of the instrument screen will change.
2	Press the <b>GPIB/RS232</b> softkey button to the right of the instrument screen. - The softkey labels will change. - The current instrument GPIB address will be displayed below the <b>GPIB Address</b> softkey label.
3	If the current GPIB address is not set to <b>1</b> , perform the following to change it:
3a	- Press the <b>GPIB Address</b> softkey button. -- The <b>GPIB Address</b> label and current GPIB address will change to boldface. -- In the on-screen Active Entry Area, <b>Address:</b> will be displayed followed by the current GPIB address.

... continued on next page

**Table I-9:** Verify and Change Agilent E4432B GPIB Address

Step	Action
3b	<ul style="list-style-type: none"> <li>- On the front panel Numeric keypad, enter the signal generator GPIB address of <b>1</b>.</li> <li>-- The <b>GPIB Address</b> label will change to <b>Enter</b>.</li> <li>-- Digits entered with the keypad will replace the current GPIB address in the Active Entry display.</li> </ul> <p><b>NOTE</b> To correct an entry, press the backspace key at the lower right of the keypad to delete one character at a time.</p>
3c	<ul style="list-style-type: none"> <li>- Press the <b>Enter</b> softkey button to set the new GPIB address.</li> <li>-- The new GPIB address will be displayed under the <b>GPIB Address</b> softkey label.</li> </ul>

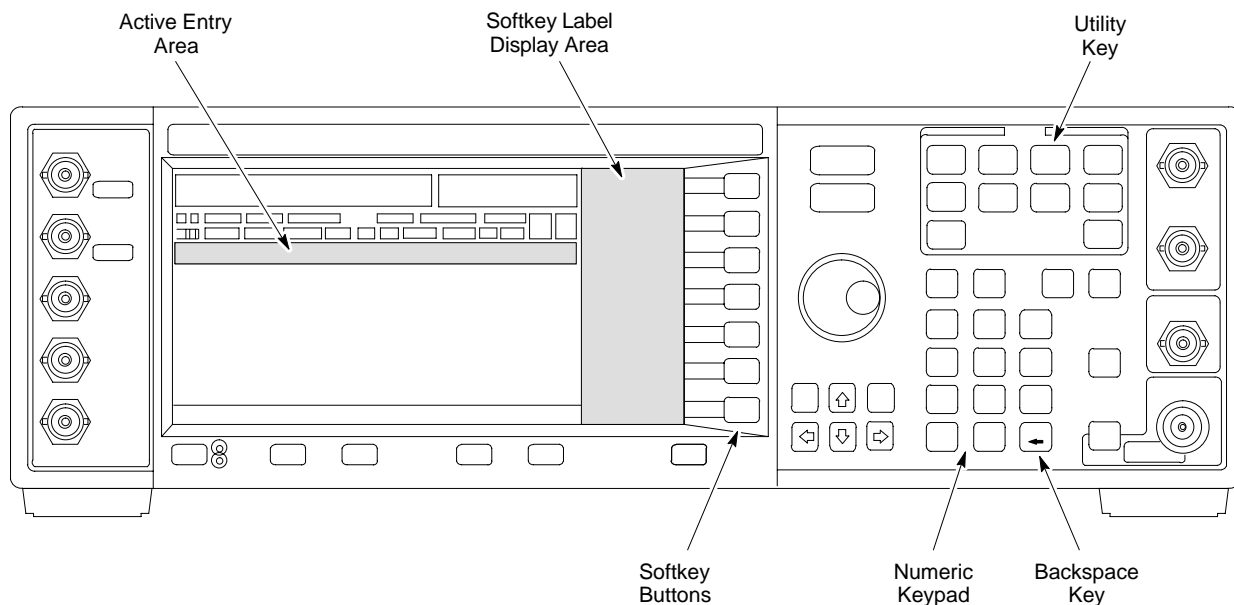
**Figure I-10:** Setting Agilent E4432B GPIB Address



*Appendix J*

# Downloading ROM

# Downloading ROM Code

## Exception Procedure - Downloading ROM Code

This procedure is not part of a normal optimization.

Perform this procedure only on an exception basis when no alternative exists to load a BTS device with the correct version of ROM code.

**NOTE** One GLI must be INS\_ACT (bright green) before ROM code can be downloaded to non-GLI devices.

**CAUTION** The correct ROM and RAM codes for the software release used on the BSS must be loaded into BTS devices. To identify the correct device ROM and RAM code loads for the software release being used on the BSS, refer to the Version Matrix section of the SC™ CDMA Release Notes (supplied on the tape or CD-ROM containing the BSS software).

All devices in a BTS must be loaded with the ROM and RAM code specified for the software release used on the BSS before any optimization or ATP procedures can be performed.

If a replacement device is loaded with ROM code which is not compatible with the BSS software release being used, the device ROM code can be changed using the LMF before performing the BTS optimization and ATPs. *A device loaded with later release ROM code can not be converted back to a previous release ROM code in the field without Motorola assistance*

If it is necessary to download ROM code to a device from the LMF, the procedure in Table J-1 includes steps *for both ROM and RAM code download using LMF.*

### Prerequisites

Prior to performing this procedure, ensure the correct ROM and RAM code files exist in the LMF computer's applicable *lmf home directory code* folder for each of the devices to be loaded.

**CAUTION** The Release level of the ROM code to be downloaded must be the one specified for the software release installed in the BSS. The release level of the ROM code resident in the other devices in the BTS must also be correct for the BSS software release being used. ROM code must not be downloaded to a frame loaded with code for a BSS software release with which it is not compatible.

*This procedure should only be used to upgrade replacement devices for a BTS. It should NOT be used to upgrade all devices in a BTS. If a BTS is to be upgraded from R15.x to R16.0, the upgrade should be done by the OMC-R using the DownLoad Manager.*





**Table J-1:** Download ROM and RAM Code to Devices

Step	Action
1	Click on the device to be loaded.  <b>NOTE</b> More than one device of the <i>same</i> type can be selected for download by either clicking on each one to be downloaded or from the BTS menu bar <b>Select</b> pull-down menu, select the <i>device</i> item that applies. Where: <i>device</i> = the type of device to be loaded (BBX, CSM, MCC)
2	From the BTS menu bar <b>Device</b> pull-down menu, select <b>Status</b> . - A status report window will appear.
3	Make a note of the number in the <b>HW Bin Type</b> column.  <b>NOTE</b> “HW Bin Type” is the Hardware Binary Type for the device. This code is used as the last four digits in the filename of a device’s binary ROM code file. Using this part of the filename, the ROM code file can be matched to the device in which it is to be loaded.
4	Click <b>OK</b> to close the status window.
5	Click on the device to be loaded.
6	<b>* IMPORTANT</b> The LMF will not automatically select ROM code files for download. ROM code files must be selected <i>manually</i> .  From the BTS menu bar <b>Device</b> pull-down menus, select <b>Download &gt; Code Manual</b> . - A file selection window will appear.
7	Double-click on the version folder with the desired version number for the ROM code file (for example <i>2.16.0.x</i> ).
8	Double-click the <b>Code</b> folder. - A list of ROM and RAM code files will be displayed.
9	<b>! CAUTION</b> A ROM code file with the correct HW Bin Type must be chosen. Using a file with the wrong HW Bin Type can result in unpredictable operation and damage to the device.  Click on the ROM code file with the filename which matches the device type and HW Bin Type number noted in step 3 (for example, file <b>bbx_rom.bin.0604</b> is the ROM code file for a BBX with a HW Bin Type of 0604). - The file should be highlighted.
10	Click on the <b>Load</b> button. - A status report window is displayed showing the result of the download.  <b>NOTE</b> If the ROM load failed for some devices, load them <i>individually</i> by clicking on one device, perform steps 6 through 10 for it, and repeat the process for each remaining device.
11	Click <b>OK</b> to close the status window.
12	From the LMF window menu bar <b>Tools</b> pull-down menus, select <b>Update NextLoad &gt; CDMA</b> .
13	In the left-hand pane of the window which opens, click on the BTS number for the frame being loaded (for example, <i>BTS-14</i> ).

. . . continued on next page

**Table J-1: Download ROM and RAM Code to Devices**

Step	Action
14	On the list of versions displayed in the right-hand pane, click the button next to the version number of the folder that was used for the ROM code download (for example, <i>2.16.0.x</i> ) and click <b>Save</b> . - A pop-up message will appear showing the CDF has been updated.
15	Click on the <b>OK</b> button to dismiss the pop-up message.
16	Click on the device that was loaded with ROM code.
17	<p><b>NOTE</b>                      RAM code is automatically selected for download.</p> From the BTS menu bar <b>Device</b> pull-down menus, select <b>Download &gt; Code/Data</b> to download RAM code and dds file data. - A status report is displayed showing the result of the download.
18	Click <b>OK</b> to close the status window.
19	Observe the downloaded non-GLI device to ensure it is OOS_RAM (yellow).
20	Click on the device which was loaded with code.
21	From the BTS menu bar <b>Device</b> pull-down menu, select <b>Status</b> . Verify that the correct ROM and RAM version numbers are displayed in the status report window.
22	Click <b>OK</b> to close the status window.



*Appendix K*

# Companion Frame Optimization

# Optimizing the Companion Frame

## Optimizing the TX section

The optimization/ATP procedure for the transmit side of the Companion Frame is identical to that of the SC4812ET BTS.

Table K-1: Optimizing the TX section of the Companion Frame		
✓	Step	Action
	1	Please refer to the TX Optimization/ATP - Chapter 3 of this manual for step-by-step TX Optimization/ATP instructions for the standalone frame
	2	Run the TX tests.

**Figure K-1:** Cabling of SC 4812ET Companion BTS to SC 4812ET Companion BTS (3 Sector)

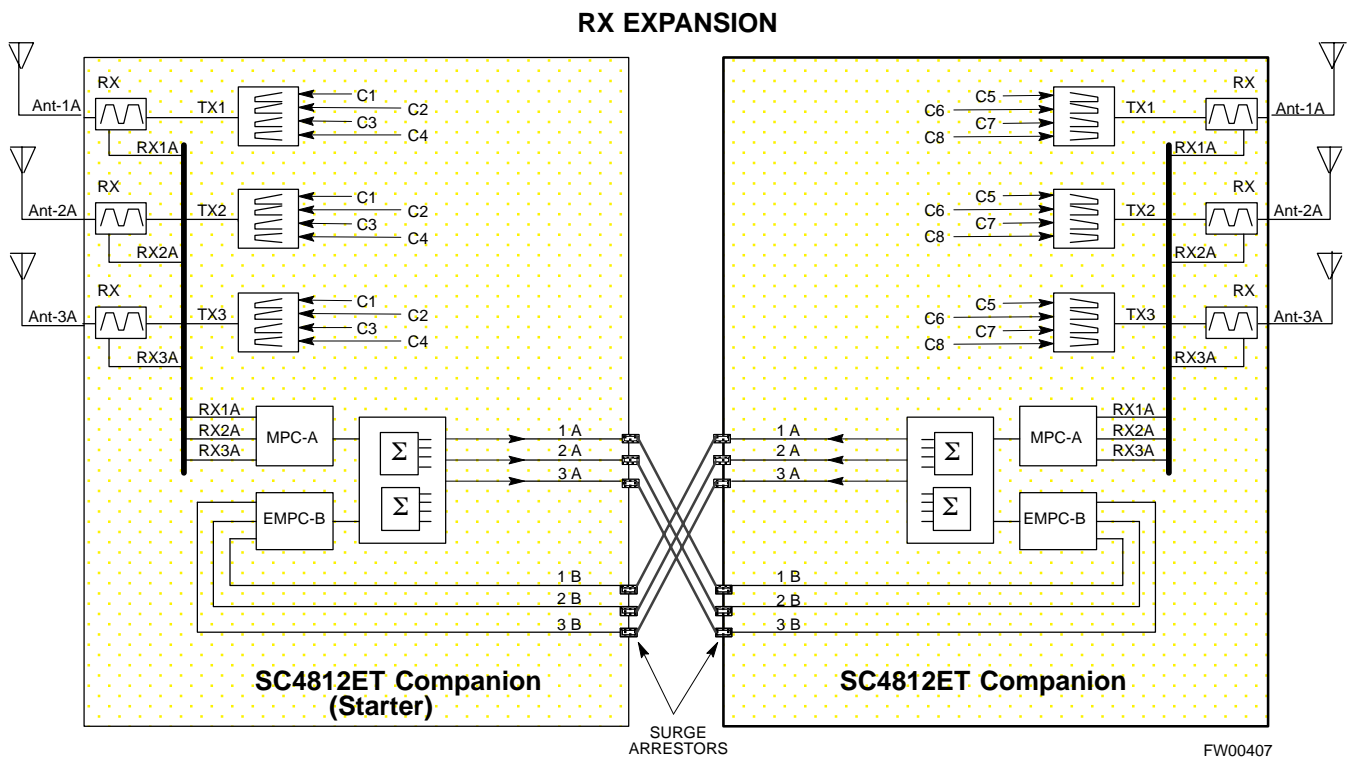

## Optimizing the RX section

### RX (Main) Optimization/ATP

To test the RX Main antenna system follow the instructions in Table K-2 and refer to illustration Figure K-1(3-sector configuration).

**Table K-2: Optimizing the RX (Main) section of the Companion Frame**

✓	Step	Action
	1	Connect the RX test cables to the antenna ports 1A-3A (for 3-sector optimization) or antenna ports 1A-6A (for 6-sector optimization).
	2	Login the LMF and select MPC (see Figure K-2 for display screen and field location).
	3	Run the RX tests.

### RX (Diversity) Optimization/ATP (Single Frame)

To test the RX Diversity antenna system follow the instructions in Table K-3.

**Table K-3: Optimizing the RX (Diversity) on a Single Frame**

✓	Step	Action
	1	Connect the RX test cables to the expansion ports on the I/O plates labeled 1B-3B (for 3-sector optimization) or expansion ports 1B-6B (for 6-sector optimization).
	2	Login the LMF under EMPC (see Figure K-2 for display screen and field location).
	3	Run the RX tests.

### RX (Diversity) Optimization/ATP (Two Frame)

To test the RX Diversity antenna configuration on a two frame Companion BTS system follow the instructions in Table K-4.

**Table K-4: Optimizing the RX (Diversity) on a Two Frame Companion Site**

✓	Step	Action
	1	<p>Connect RX expansion cables from the expansion ports on the other Companion frame labeled 1A-3A (for 3-sector optimization) or expansion ports 1A-6A (for 6-sector optimization) to the 1B-3B (for 3-sector optimization) or expansion ports 1B-6B (for 6-sector optimization) see Figure K-1 for an illustration of the configuration.</p> <p><b>NOTE</b> Connect the cables from the 2nd frame A ports to the B ports of the 1st frame.</p>
	2	<p>Login using the LMF select MPC (see Figure K-2 for field location on LMF display screen)</p> <p><b>NOTE</b></p> <ul style="list-style-type: none"> <li>- Although the test will be done to one frame, the RX cable will be connected to the other frame's corresponding antenna ports.</li> <li>- The other frame has to be powered up and include all the RX Path Components.</li> </ul>

K

Figure K-2: WinLMF Display Screen

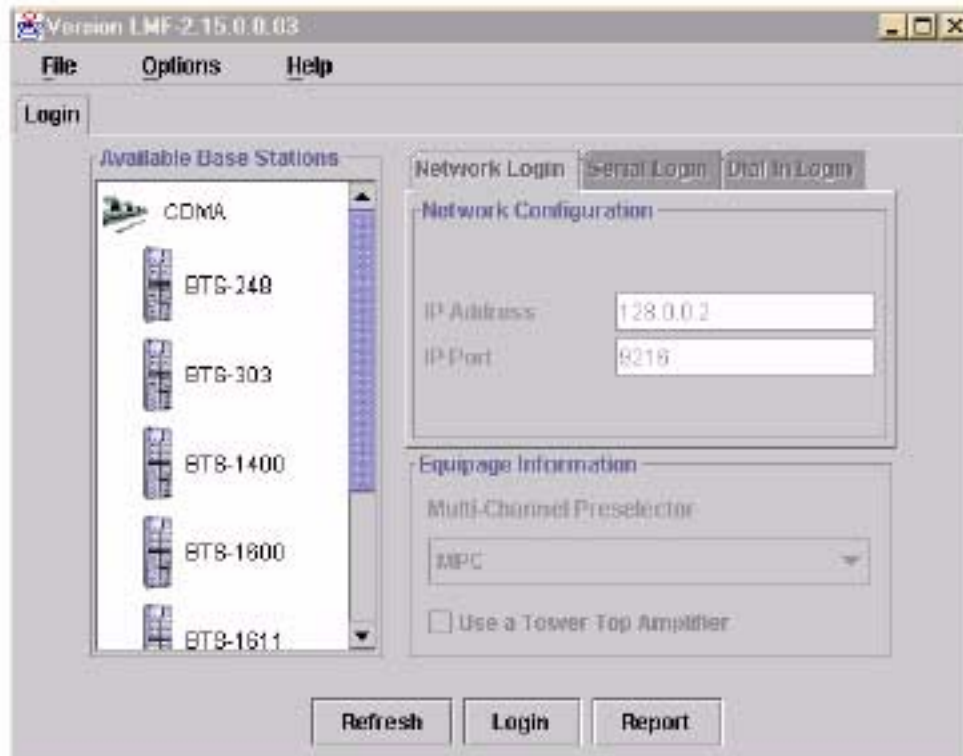



---

*Index*

## Numbers

10BaseT/10Base2 Converter, 1-12

2-way Splitter, 1-15

3-Sector Duplexed Directional Coupler to RFDS  
Cabling Table, H-23

4812ET RF Cabinet Internal FRU Locations, H-4

6-Sector Duplexed Directional Coupler to RFDS  
Cabling Table, H-24

## A

Acceptance Test Procedures ATP , 1-3

Acronyms, 1-16

ACTIVE LED

GLI, 6-41

MCC, 6-44

Advantest R3465, 3-64

GPIB, I-9

Alarm and Span Line Cable Pin/Signal Information,  
3-8

ALARM LED, GLI, 6-41

Alarm Monitor window, 3-130

Alarm Reporting Display, 3-130

All Cal/Audit Test, 3-113

All inclusive, TX ATP test outline - CCP shelf 1,  
primary, 4-18

All tests fail on a single antenna, Troubleshooting,  
RFDS, 6-35

AMR, 1-21

Applying AC Power, 2-6

ATP

generate failure report, 4-17

generate report, 4-17

test matrix/detailed optimization, B-3

ATP - Reduced, 4-3

ATP Report, 4-18

ATP Test Procedure, 4-9

## B

Basic Troubleshooting Overview, 6-2

Battery Charge Test (Connected Batteries), 2-12

Battery Discharge Test, 2-12

Bay Level offset calibration failure, 6-10

BBX, gain set point vs SIF output considerations, C-2

BBX2, 1-21

BBX2 Connector, 6-25

BBX2 LED Status Combinations, 6-43

Broad Band Receiver. *See* BBX

BTS

download, 3-42

Ethernet LAN interconnect diagram, 3-25

LMF connection, 3-12, 3-24

system software download, 3-3

BTS Cabinet, 1-28

BTS directory, create, 3-28

Create CAL File, 3-114

## C

C-CCP Backplane, H-7

C-CCP Backplane Troubleshooting, Procedure, 6-26

C-CCP shelf, 1-21

cable calibration, automatic, test set-up, 3-72

Advantest R3267/R3562, 3-72

Advantest R3465, 3-71

Agilent 8935, 3-71

Agilent E4406A/E4432B, 3-72

CyberTest, 3-71

HP 8921A, 3-71

Cables Connection for 10 MHz Signal and GPIB ,  
F-4, F-6

Calibrate BLO, 3-98

Calibrating Cables, 3-90

Calibrating Test Cable Setup, PCS Interface  
HP83236B, F-16

Calibrating Test Equipment, 3-89

Calibration

data file calibration, BLO, 3-100

In-Service, G-18

power meter, Gigatronics 8542B, F-25

Calibration Audit failure, 6-11

calibration data file, description of, BLO, 3-100

Cannot communicate to Communications Analyzer,  
6-5

Cannot communicate to Power Meter, 6-4

Cannot Download DATA to any device card, 6-6, 6-7

Cannot ENABLE device, 6-8

Cannot Log into cell-site, 6-3



- Cannot perform carrier measurement, 6-16
  - Cannot perform Code Domain Noise Power measurement, 6-15
  - Cannot perform Rho or pilot time offset measurement, 6-14
  - Cannot perform Txmask measurement, 6-13
  - CCD, 1-21
  - CCP, shelf 1 - all inclusive TX ATP test outline, primary, 4-18
  - CDF
    - site configuration, 3-3
    - site equipage verification, 3-4
    - site type and equipage data information, 2-2
  - CDF file
    - create, 3-31
    - update device load version, 3-32, 3-33
  - CDMA
    - allocation diagram for the North American, cellular telephone frequency spectrum, D-6
    - optimization/ATP test matrix, B-2
  - cdpower test, 4-14
  - Cell Site
    - equipage verification, 2-2
    - types configuration, 3-3
  - Cell Site Data File. *See* CDF
  - Cell Site Field Engineer CFE, 1-3
  - Channel Service Unit, 3-6
  - CIO, 1-21
  - CIO Connectors, 6-25
  - CLI, 1-4
  - Clock Sync Module. *See* CSM
  - Code Domain Power and Noise Floor Levels, 4-15
  - Code Domain Power/Noise, 4-14
  - Communication test set, rear panel, F-4, F-6
  - Communications System Analyzer, 1-13
  - Communications system analyzer , 1-13
  - Components Located on CIO Card, H-11
  - Connecting test equipment to the BTS, 3-62
  - Connector Functionality
    - Backplane, Troubleshooting, 6-24
    - Troubleshooting, Backplane, 6-24
  - Copy CAL Files From Diskette to the CBSC, 5-4
  - Copy CDF Files from CBSC, 3-19
  - Copy Files from LMF to Diskette, 5-4
  - Copying CAL files from CDMA LMF to the CBSC, 5-4
  - Copying CAL files to the CBSC, 5-4
  - create
    - BTS directory, 3-28
    - CDF file, 3-31
    - master-bts-cdma, 3-28
  - CSM, 1-21
    - and LFR primary functions, 3-52
  - CSM frequency verification, 3-54
  - CSM LED Status Combinations, 6-39
  - Customer I/O, 1-21
  - CyberTest, 3-64
  - CyberTest Communication Analyzer, 1-13
- ## D
- DC Power Pre-test (BTS Frame), 2-8
  - DC Power Problems, C-CCP Backplane Troubleshooting, 6-30
  - DC/DC Converter LED Status Combinations, 6-38
  - Detailed, optimization/ATP test matrix, B-3
  - Devices, download. *See* Download
  - Digital Control Problems, 6-27
    - C-CCP Backplane Troubleshooting, 6-27
  - Digital Multimeter, 1-14
  - Directional Coupler, 1-14
  - Download
    - See also* Devices
    - BTS, 3-42
    - BTS system software, 3-3
  - Download BLO Procedure, 3-106
  - download ROM and RAM code. *See* ROM code
  - Download/Enable MCCs, 3-51
  - Download/Enable MGLIs, 3-45
  - Duplexer/Directional Coupler DDC, 1-20, 1-21, 1-22, 1-30
- ## E
- Enable CSMs & BDCs, 3-49
  - Equipment Overview, 1-18
  - Equipment warm-up, 3-68
  - Ethernet LAN
    - interconnect diagram, 3-25
    - transceiver, 1-12
  - ETIB I/O Connectors, H-13

Every test fails, Troubleshooting, RFDS, 6-33

## F

fer test, 4-16

Files, calibration data file, BLO, 3-100

Folder Structure Overview, 3-21, 3-23

Foreword, xx

FREQ Monitor Connector, CSM, 6-40

Frequency counter, optional test equipment, 1-15

## G

Gain set point, C-2

General Safety, xxii

General optimization checklist, test data sheets, A-6

Gigatronics 8542B power meter, illustration, F-25,  
I-4

Gigatronics Power Meter, 3-64

GLI. *See* Master (MGLI2) and Slave (SGLI2) Group  
Line Interface

GLI Connector, 6-25

GLI Ethernet A and B Connections, 6-25

GLI LED Status Combinations, 6-41

GLI Pushbuttons and Connectors, 6-42

GLI2, 1-21

GLI2 Front Panel Operating Indicators, 6-42

GPIB, F-3, F-7, F-11

Advantest R3465, I-9

HP83236A/B, I-7

HP8921A, I-7

HP8935, I-6

power meter

Gigatronics 8542B, I-4

HP437B, I-3

set address, Motorola CyberTest, I-5

GPIB Cables, 1-13

GPS, receiver operation, test data sheets, A-7

GPS Initialization/Verification

estimated position accuracy, 3-55

surveyed position accuracy, 3-55

GPS satellite system, 3-49

Graphical User Interface Overview, 3-34, 3-35

Group Line Interface. *See* GLI

## H

Hardware Requirements, 1-9

High Stability 10 MHz Rubidium Standard, 1-15

High-impedance Conductive Wrist Strap, 1-14

HP 437B, 3-64

HP 83236A, F-7

HP 8921, 3-64

HP83236A/B, GPIB, I-7

HP8921A, F-7

GPIB, I-7

HP8935, GPIB, I-6

HP8935 Analyzer, 1-13

HSO, 1-21

HSO Initialization/Verification, 3-53

## I

I and Q values, E-3

In-Service Calibration, G-18

Initial HP8921A setup, F-16

Initial Installation of Boards/Modules, preliminary  
operations, 2-2

Initial power tests, test data sheets, A-5

Installation and Update Procedures, 3-16

Intercabinet I/O, 1-22

Internal FRU, 1-29

Internal FRUs, 1-20

IS-97 specification, E-3

ISB Inter Shelf Bus connectors, 6-24

## L

LAN, BTS frame interconnect, illustration, 3-25

LED Status Combinations for all Modules except  
GLI2 CSM BBX2 MCC24 MCC8E, 6-37

LFR, 1-21

receiver operation, test data sheets, A-8

Line Build Out parameters

configure, 5-8

verify, 5-6

LMF, F-3, F-11

to BTS connection, 3-12, 3-24

view CDF information, 3-4

LMF Removal, 5-12

Load Center Wiring, 2-5

Local Area Network (LAN) Tester, 1-15

Log into the BTS, 3-27

Log into the LMF, 3-27

Logging In to a BTS, 3-36

Logging Out, 3-39

LORAN-C Initialization/Verification, 3-60

LPA errors, 6-9

LPA Module LED, 6-45

LPA Shelf LED Status Combinations, 6-45

LPAC Interface Board, H-12

## M

major components, 1-19

Manual, layout, 1-2

Master Group Line Interface. *See* MGLI

MASTER LED, GLI, 6-41

master-bts-cdma directory, create, 3-28

MCC LED Status Combinations, 6-44

MCC/CE, 4-14

MGLI2, board detail, MMI port connections, 5-7

MMI common connections, 3-41

MMI Connection, 3-41

MMI Connector

CSM, 6-40

GLI, 6-42

MMI Connectors, MCC, 6-44

MMI equipment setup, 3-41

Model SLN2006A MMI Interface Kit, 1-13

Module status indicators, 6-36

Motorola, SC9600 Base Transceiver Subsystem, 1-2

MPC, 1-21

Multi Channel Card. *See* MCC

Multi-FER test Failure, 6-17

## N

New Installations, 1-6

No AMR control, 6-28

No BBX2 control in the shelf, 6-28

No DC input voltage to Power Supply Module, 6-30

No DC voltage +5 +65 or +15 Volts to a specific  
GLI2 BBX2 or Switch board, 6-31

No GLI2 Control through span line connection, 6-27

No GLI2 Control via LMF, 6-27

No or missing MCC24 channel elements, 6-29

No or missing span line traffic, 6-28

North American, cellular telephone system frequency  
spectrum, CDMA allocation, D-6

Null modem cable detail, 1-12

## O

Online Help, 1-4

Optimization, 1-3

optimization/ATP, test set-up, 3-76

Advantest R3267/R3562

DRDCs, 3-79

TRDCs, 3-81

Advantest R3465, 3-76

Agilent 8935

DRDCs, 3-78

TRDCs, 3-80

Agilent E4406A/E4432B

DRDCs, 3-78

TRDCs, 3-80

CyberTest, 3-76

HP 8921A, 800 MHz, 3-77

HP 8921A, 1.9 GHz, 3-77

Optimization/ATP Test Matrix, 1-6

Optional Test Equipment, 1-15

Optional test equipment, frequency counter, 1-15

Oscilloscope, 1-15

## P

Pilot Time Offset. *See* PN

Ping, 3-25

- PN  
 offset programming information, E-2  
 offset usage, E-3
- PN offset per sector, E-3
- PN Offset Usage , E-3
- Power Delta Calibration  
 Advantest, G-7  
 HP8921A, G-4  
 HP8935, G-10
- Power Input, 6-24
- Power Meter, 1-13  
 illustration, F-23, I-3  
 Pre-calibration, F-23
- Power meter  
 calibration, Gigatronics 8542B, F-25  
 GPIB  
 Gigatronics 8542B, I-4  
 HP437B, I-3  
 illustration, Gigatronics 8542B, F-25, I-4
- Power Supply Module Interface, 6-24
- Pre-calibration, Power Meter, F-23
- Pre-power tests, test data sheets, A-5
- Preliminary operations  
 cell Site types, 2-2  
 test data sheets, A-4
- Prepare to Leave the Site  
 External test equipment removal, 5-2  
 LMF Removal, 5-12  
 Reestablish OMC-R control, 5-13  
 Verify T1/E1, 5-13
- Prepare to leave the site  
 re-connect BTS IFM connector, 5-11  
 re-connect BTS T1 spans, 5-11
- Procedures to Copy CAL Files From Diskette to the  
 CBSC, 6-3, 6-4, 6-5, 6-6, 6-7
- Product Description, 1-4
- Pseudorandom Noise. *See* PN
- ptoff test, 4-13
- Punch Block, 3-8
- PWR/ALM and ACTIVE LEDs, MCC, 6-44
- PWR/ALM LED  
 BBX2, 6-43  
 CSM, 6-39  
 DC/DC Converter, 6-38  
 generic, 6-37  
 MCC, 6-44  
 MPC and EMPC Card, H-21
- R**
- RAM code, described, 3-42
- Re-connect BTS IFM connector, 5-11
- Re-connect BTS T1 Spans, 5-11
- Receive Distribution Card RXDC, 1-30
- Reduced ATP, 4-3
- Reduced ATP passes but forward link problem  
 prevails, 6-12
- Reestablish OMC-R control, 5-13
- Removing and Installing LPAs for the SC 4812ET,  
 H-8
- Required documents, 1-7, 1-29
- Required Test Equipment  
 Ethernet LAN transceiver, 1-12  
 substitute equipment, 1-8
- RESET Pushbutton, GLI, 6-42
- Resetting BTS modules, 5-3
- Revision History, xxiv
- RF Adapters, 1-14
- RF Attenuators, 1-14
- 50 Pair Punchblock, H-27
- RF Path Bay Level Offset Calibration, 3-97
- RF Test Cable, 1-15
- RFDS Cabling Details, H-23
- RFDS calibration  
 description, 3-125  
 procedure, 3-126
- RFDS FRU, H-15
- RFDS Location, SC 4812ET, 1-24
- RFDS parameters, 3-116  
 checking, 3-117  
 setting, 3-117
- RFDS Test Subscriber Unit, 3-43
- RFDS TSU Calibration Channel Frequencies, 3-125
- rho test, 4-12
- ROM code  
 described, 3-42  
 downloading, J-2, K-2, K-3  
 procedure, J-3

RS-232 to GPIB Interface, 1-12

Rubidium Standard Timebase, 3-64

RX, antenna VSWR, test data sheets, A-18

RX and TX paths fail, Troubleshooting, RFDS, 6-34

## S

SC 4812 BTS Optimization/ATP Test Matrix, B-4

SC 4812ET BTS Combiner, H-9, H-10, H-17, H-18, H-19, H-20, H-22, H-23, H-25

SCLPA, convergence test data sheets, A-9

Selecting Test Equipment, 3-85

Set Antenna Map Data, 3-123

Set RFDS Configuration Data, 3-124

Set Span Parameter Configuration, procedure, 5-8

Setting Cable Loss Values, 3-94

Setting Control Port, 3-6

Setting Coupler Loss Value, 3-95

SGLI2, board detail, MMI port connections, 5-7

SIF, output considerations vs BBX gain set point, C-2

Site, equipage verification, 3-4

Site checklist, verification data sheets, A-3

site equipage, CDF file, 3-3

Site Specific BTS Files, 3-28

Span Framing Format  
     configure, 5-8  
     verify, 5-6

SPAN I/O Functional Description, Introduction, H-14

Span Line (T1/E1) Verification Equipment, 1-15

Span Line connector , 6-24

Span Parameter Configuration  
     set, procedure, 5-8  
     verification, procedure, 5-6

Span Problems no control link, Troubleshooting, 6-46

SPANS LED, 6-41

Spectrum Analyzer, 1-15

Spectrum Analyzer , HP8594E, 3-64

STATUS LED, GLI, 6-41

SYNC Monitor Connector, CSM, 6-40

System Connectivity Test, F-7

## T

T1, isolate BTS from the T1 spans, 3-5, 3-14

Telco Interface Board TIB, 1-30

Test data sheets  
     Alarm verification, A-19  
     general optimization checklist, A-6  
     GPS receiver operation, A-7  
     initial power tests, A-5  
     LFR receiver operation, A-8  
     pre-power tests, A-5  
     preliminary operations, A-4  
     RX antenna VSWR, A-18  
     SCLPA convergence, A-9  
     site checklist, A-3  
     TX antenna VSWR, A-16  
     TX BLO, A-10, A-15  
     verification of test equipment used, A-2

Test equipment, verification data sheets, A-2

Test equipment connections , F-3  
     preliminary Agilent E4406A/E4432B set-up, F-15

Test Equipment Policy, 1-8

Test Equipment Setup Calibration for TX Bay Level Offset, 3-93, F-20

Test Equipment Setup Chart, 3-66

Test equipment setup RF path calibration, 3-103

Timing Reference Cables, 1-13

Transmit TX path audit, 3-109

Transmit TX path calibration, 3-104

Transmit/Receive Module TRX, 1-29

Troubleshooting  
     DC Power Problems, 6-30  
     Span Problems no control link, 6-46

Troubleshooting Forward Link Failure (BTS Passed Reduced ATP), 6-12

TSU NAM, programming  
     description, 3-120  
     parameter ranges, 3-122  
     parameters, 3-121  
     procedure, 3-128

## TX

antenna VSWR, test data sheets, A-16, A-19

BLO test data sheets, A-10, A-15

TX and RX Frequency vs Channel , D-4

TX Audit Test, 3-110

TX Bay Level Offset and TX ATP test equipment setup calibration, 3-92

TX calibration, set-up, 3-73

Advantest R3267, 3-75

Advantest R3465, 3-74

Agilent 8935, 3-73

Agilent E4406A, 3-75

CyberTest, 3-73

HP 8921A, 3-74

tx fine adjust, E-3

TX Mask Verification, spectrum analyzer display,  
illustration, 4-11

TX Output Acceptance Tests - Introduction

Code domain power, 4-8

Pilot time offset, 4-8

Spectral purity TX mask, 4-8

Waveform Quality (rho), 4-8

TX Path Calibration, 3-99

TX/RX OUT Connections, 4-5

txmask test, 4-10

## U

Updating CDMA LMF Files, 5-4

## V

Verify, test equipment used, test data sheets, A-2

Verify GLI ROM code load, 3-44

Verify Span Parameter Configuration, procedure, 5-6

## W

Walsh channels, 4-14

## X

XCVR Backplane Troubleshooting, 6-24

Xircom Model PE3-10B2, LMF to BTS connection,  
3-24