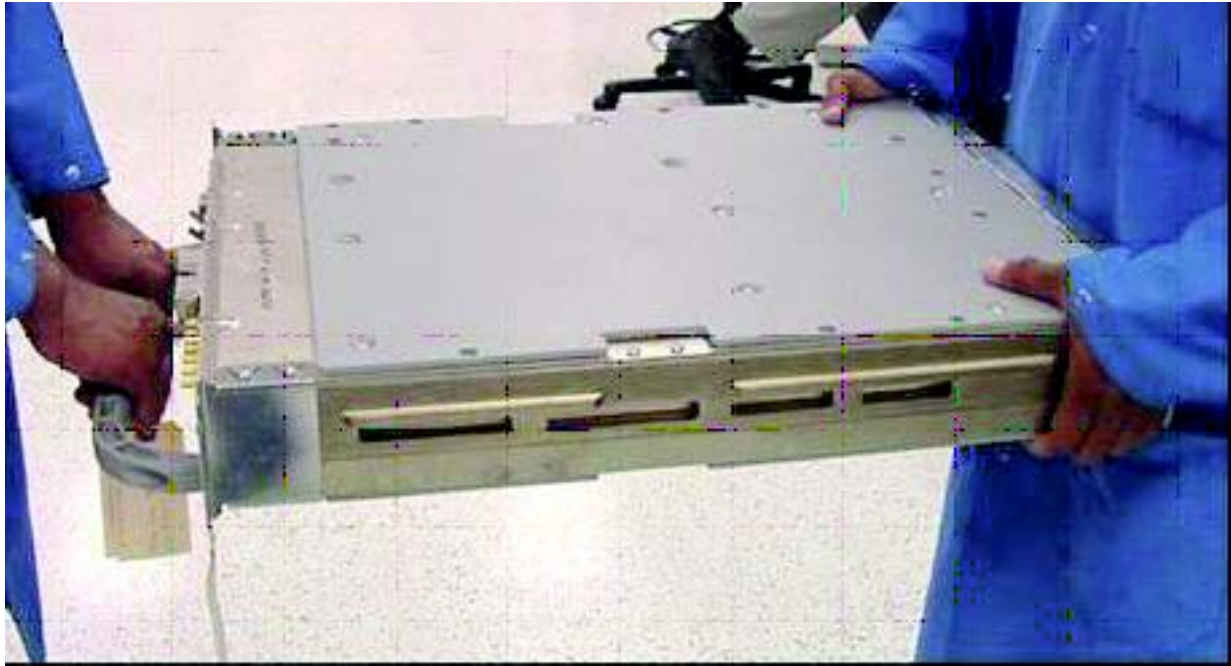

Figure 7-3 Two People Properly Carrying an XMI (removable XMI handle attached)



ti-cdma-05891.eps

XMI Installation Procedure

Follow the steps in [Procedure 7-2](#) to install the XMI.

Procedure 7-2 XMI Installation Procedure

AT THE BTS SITE



CAUTION

The XMI module is heavy. Two people are required to lift, carry, or handle the XMI module.

- Be sure the removable XMI handle is attached to the front of the XMI before physically handling the module.
- Be sure two people use both hands and wear protective footwear when handling the XMI.
- Be sure to use two people to support the module while sliding the module out of or into the shelf slot.



CAUTION

An XMI module that is not in a shelf should always be set on its side and never on its edge. This will prevent the XMI module from tipping over and causing damage or injury.

-
- | | |
|----------|---|
| 1 | The replacement XMI module should already have the removal handle attached. If handle <i>is not</i> attached, go to step 2 . If handle is attached, go to step 3 . |
| 2 | <p>Attach the removable XMI handle to the front of the replacement XMI module (see Figure 1-9 800 MHz XMI Module Front Panel I/O Detail on page 1-38 or Figure 1-10 1.9 GHz XMI Module Front Panel I/O Detail on page 1-39 for location of XMI handle mounting screw holes) as follows:</p> <ul style="list-style-type: none"> • Align handle screw holes with handle mounting screw holes on the XMI front panel. (Note handle orientation; handle is not symmetrical.) • Insert two M5 screws. • Using a T25 TORX driver, tighten the screws to 3.2-3.6 N-m (28-32 in-lb). |
-

Continued

Procedure 7-2 XMI Installation Procedure (Continued)

3	<p>This step requires two people. Perform the following:</p> <ul style="list-style-type: none"> • (See Figure 7-3 Two People Properly Carrying an XMI (removable XMI handle attached) on page 7-18.) One person grasp the XMI by the handle with both hands. The second person grasp the XMI fan tray sides with both hands. Using safe lifting technique (i.e. lift with your legs not your back), Use legs to lift (Do not use your back) pick up the XMI and carry it over to the front of the frame. • (See Figure 7-2 Two People Properly Removing/Installing an XMI (removable XMI handle attached) on page 7-17.) While one person holds the XMI by the handle with both hands, the second person supports the bottom of the module with one hand and the top of the module with the other hand. Lift the XMI into the appropriate slot rails and gently slide it all of the way into the shelf slot.
4	Insert the four XMI mounting screws; two screws at each of the top and bottom mounting tabs on the front of the module. Using a T25 TORX driver, tighten the screws to 4.77 N-m (42 in-lb).
5	<p>If desired, remove the handle from the front of the replacement XMI module as follows:</p> <ul style="list-style-type: none"> • Using a T25 TORX driver, remove the two screws that secure the handle to the XMI front panel. • Retain the two screws with the XMI handle for future use.
6	For 800 MHz XMI only, install the TXD attenuator, previously removed from the failed XMI, into the TXD connector on the front panel of the replacement XMI.
7	Reconnect all cables to the XMI front panel.
8	Restore power to the XMI by setting the corresponding XMI PDU DC circuit breaker to ON (pushed in).
9	This completes the physical installation of the FRU. If optimization is to be performed at this time, see Optimization Recommended following this table.

AT THE OMCR

10	Open a CLI window. Refer to Accessing OMCR CLI window on page 3-3.
11	<p>Display the overall status of all devices at the BTS, including the XMI, by entering the following command at the prompt:</p> <pre>omc-000000>DISPLAY BTS-<bts#> STATUS</pre>
12	Determine the status of XMI 1 by observing the BTS STATUS report.
13	<p>Unlock the replacement XMI by entering the following command at the prompt:</p> <pre>omc-000000>UNLOCK XMI-<bts#>-<xmi#> UNC</pre>
14	<p>Display the status of the XMI by entering the following command at the prompt:</p> <pre>omc-000000>DISPLAY BTS-<bts#> STATUS</pre> <p>Verify that the replacement XMI is in an INS_ACTIVE state.</p>
15	From the OMCR, monitor the Alarm Manager. Verify that old alarms are cleared and no new alarms are reported.

Optimization Recommended

Perform the following BTS Optimization/ATP procedures:

- BTS Device Database Audit
- BTS Device Database Update
- TX Path Calibration Audit
- Spectral Purity TX Mask ATP (optional)
- Waveform Quality (Rho) ATP (optional)
- Code Domain Power ATP (optional)
- RSSI Test (FER Test is optional)

Refer to the *1X UBS Macro BTS Optimization/ATP* manual for the optimization procedures.

XMI Fan Tray Assembly

XMI Fan Tray Assembly Description

The XMI fan tray assembly consists of five 27 V DC fans mounted in a housing. This housing is the removable rear panel of the XMI. (See [Figure 7-4](#) and [Figure 7-5](#).)

The fan tray assembly mounted on the rear of the XMI draws cooling air in from air vents on the XMI front panel through the XMI and exhausts air out the XMI rear panel.

The XMI fan housing contains five fan mounting locations. Each fan mounting location has the following:

- built-in fan grille/finger-guard
- four vibration isolator fan mounting posts
- fan connector bracket

Each individual fan has a electrical wiring and connector. The connector mounts in the corresponding fan connector bracket.

The XMI fan tray assembly is attached to the rear of the XMI and secured with four screws. When the XMI fan tray assembly is attached to the rear of the XMI, the five fan connectors mate with connectors on the XMI Fan Interconnect Board (FIB).

The XMI FIB provides a DC voltage connection to each fan in the fan tray assembly and is a conduit for fan speed information and control.

The XMI PA Controller (XPAC) provides central control of the three LPA sections. In addition, the XPAC gathers LPA alarms and provides XMI fan speed control.

System Impact/Considerations

Typically the XMI fan tray assembly replacement requires that the affected XMI be physically removed from the UBS Macro BTS frame. However, if the rear of the frame is accessible, the XMI fan tray assembly can be replaced without physically removing the affected XMI from the frame.



NOTE

Performing this replacement procedure on a frame with only one XMI will cause BTS downtime and suspend call processing.

If the frame is equipped with only one XMI, BTS service will be interrupted during the XMI fan tray assembly replacement. If the frame is equipped with more than one XMI, only the affected XMI will be out-of-service and the BTS will remain in service.

Alarms will be reported during the replacement procedure.

Table 7-4 FRU Replacement Conditions

FRU	What to Shut Down...
XMI fan tray assembly	From the OMCR, lock the XMI being removed. Then shut down XMI DC input power.

XMI Fan Tray Diagrams

[Figure 7-4](#) shows how the fan tray assembly is attached to the rear of the XMI.

[Figure 7-5](#) shows the fan tray assembly with five fans, built-in fan grille/finger-guards and five fan connector brackets with individual fan connectors and wiring.

Figure 7-4 XMI Fan Tray Assembly (Removal & Installation)

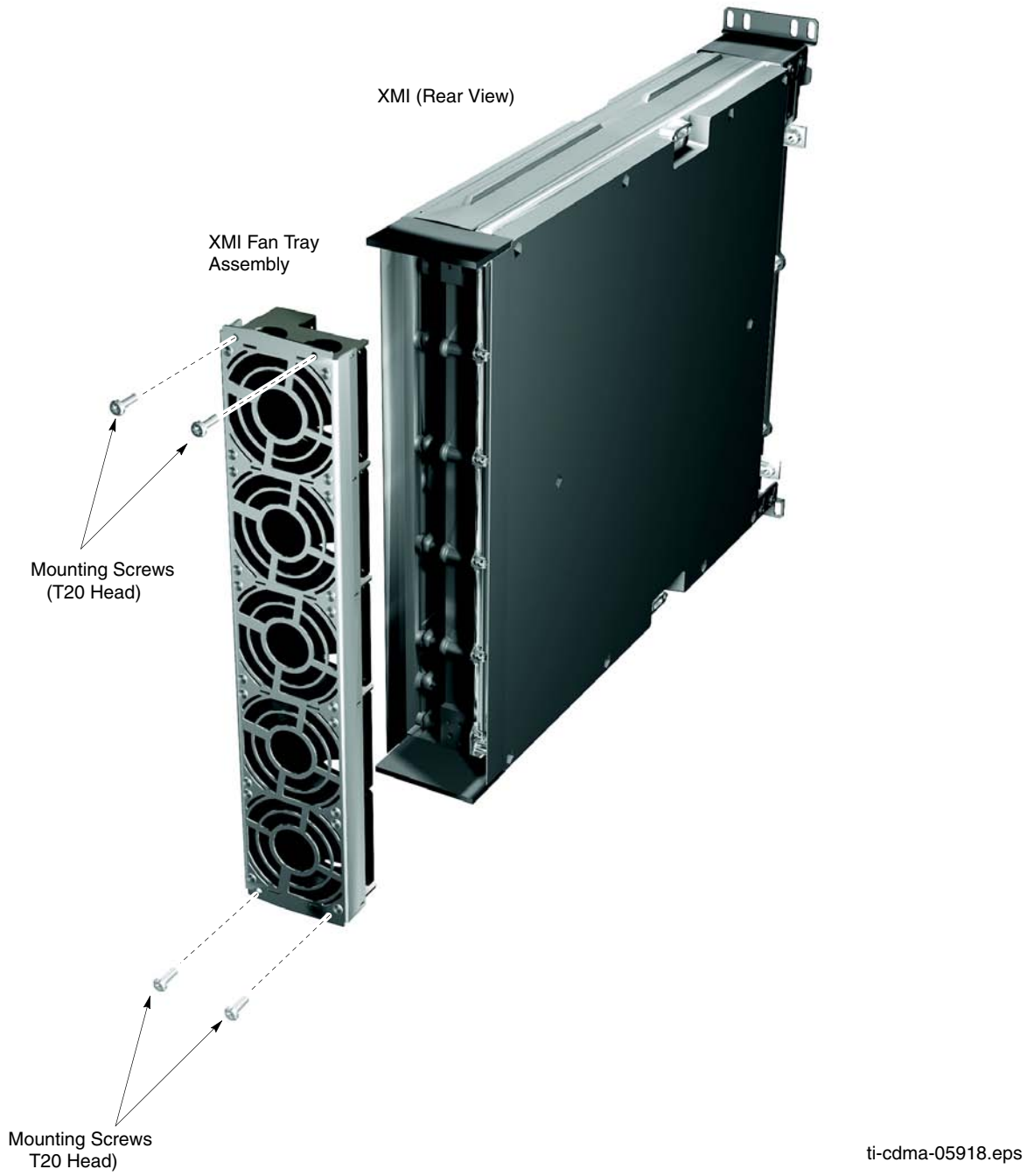

ti-cdma-05918.eps

Figure 7-5 XMI Fan Tray Assembly (External & Internal Views)

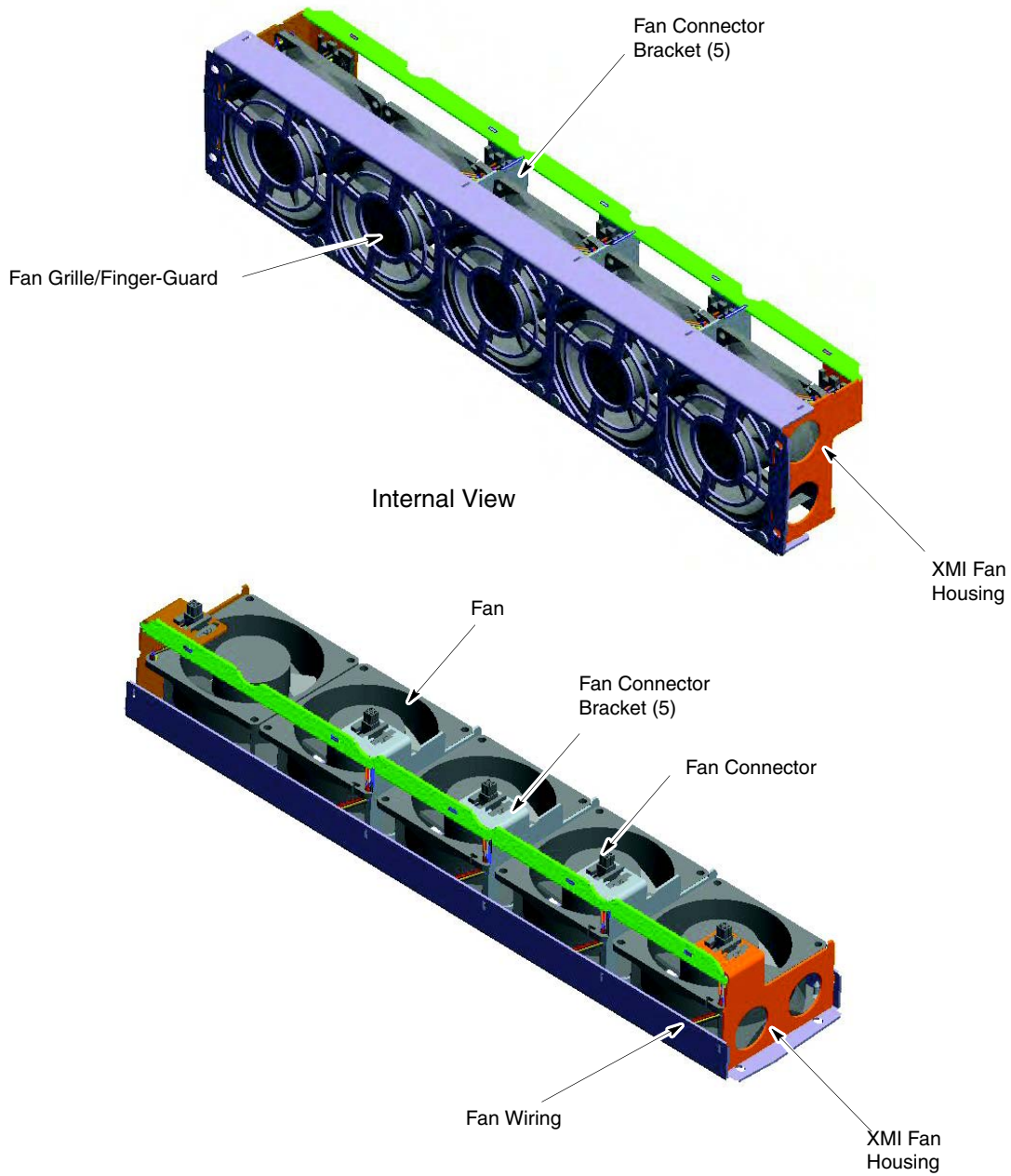

ti-cdma-05919.eps

Required Items

Manpower

- Two people are required to lift, carry, or handle the XMI module.

Documents

- None

Tools

- T20 TORX Bit
- T25 TORX Bit
- Torque Driver
- XMI removable handle with two M5 screws
- Heat protective gloves for handling/touching a "HOT" XMI

Replacement Unit

- XMI fan tray assembly with five 27 V DC fans (Motorola model STLN6404)

Prerequisites



WARNING

Do not touch the XMI with unprotected hands when the "HOT" label is fully visible. If the "HOT" label is fully visible, wear heat protective gloves when touching the metal case of the XMI. The "HOT" label becomes fully visible when the temperature of the metal case of the XMI reaches 50 degrees C. However, the label may be partially visible at lower case temperatures.



WARNING

XMI fans must be completely stopped before removing the XMI fan tray assembly.



CAUTION

The XMI should be locked by the OMCR operator just prior to removing the XMI or the XMI fan tray assembly.



NOTE

Coordinate this repair task with the OMCR operator.

Before You Begin

Before you begin, record the pertinent information in the following table (see [Table 7-5](#)):

Table 7-5 Item Number Replacement List

Item	Number
BTS number	
XMI number	

XMI Fan Tray Assembly Replacement

Follow the steps in [Procedure 7-3](#) to replace an XMI fan tray assembly.

Procedure 7-3 XMI Fan Tray Assembly Replacement Procedure

AT THE BTS SITE	
1	Notify the OMC-R operator that you are replacing the XMI fan tray assembly.
	<p>WARNING</p> <p>Do not touch the XMI with unprotected hands when the "HOT" label is fully visible. If the "HOT" label is fully visible, wear heat protective gloves when touching the metal case of the XMI. The "HOT" label becomes fully visible when the temperature of the metal case of the XMI reaches 50 degrees C. However, the label may be partially visible at lower case temperatures.</p>
2	If the affected XMI is going to be removed from the frame in order to replace the XMI fan tray assembly, go to Procedure 7-1 XMI Removal Procedure on page 7-14 and perform the steps starting at step 2 . Then return to step 3 of this procedure. If the affected XMI is going to be accessed from the rear of the frame in order to replace

Continued

Procedure 7-3 XMI Fan Tray Assembly Replacement Procedure (Continued)

the XMI fan tray assembly, go to [Procedure 7-1 XMI Removal Procedure on page 7-14](#) and perform the steps starting at [step 2](#), but stop after [step 8](#). Then return to [step 3](#) of this procedure.

**WARNING**

XMI fans must be completely stopped before removing the XMI fan tray assembly.

- | | |
|----------|---|
| 3 | Working at the rear of the affected XMI, make sure that all five of the XMI fans have completely stopped. |
| 4 | Using a T20 TORX driver, remove the four XMI fan tray assembly mounting screws (see Figure 7-4 for screw locations.) |
| 5 | Grasp the XMI fan tray assembly and firmly pull it away from the rear of the XMI. |
| 6 | Properly position the replacement XMI fan tray assembly at the rear of the XMI. Make sure that all five fan connectors are properly aligned with the mating connectors on the XMI. |
| 7 | Firmly push the XMI fan tray assembly onto the rear of the XMI. Make sure that all five fan connectors are fully seated. |
| 8 | Insert the four XMI fan tray assembly mounting screws. Using a T20 TORX driver, tighten the screws to 1.6 - 1.8 N-m (14 - 16 in-lb). |
| 9 | If the affected XMI is removed from the frame, go to Procedure 7-2 XMI Installation Procedure on page 7-19 and perform the steps starting at step 3 .
If the affected XMI is being accessed from the rear of the frame, go to Procedure 7-2 XMI Installation Procedure on page 7-19 and perform the steps starting at step 8 . |

**NOTE**

There is no optimization required for XMI fan tray assembly replacement.

DMI Replacement Procedures

DMI Replacement Procedures

Introduction

This chapter includes FRU replacement procedures for the following:

- **DMI (Digital Module Internal) Assembly** – This section covers the following:
 - c Preparing the replacement DMI assembly in the Field.
 - c Replacing the DMI.
 - c Dismantling the failed DMI assembly in the Field.
 - c and more
- **Modem Boards** – This section covers the replacement of a failed 1X CDMA or EV-DO modem board in a UBS Macro BTS DMI.

DMI (Digital Module Internal) Assembly



NOTE

The R20 UBS Macro BTS only supports frame configurations with up to two DMIs and up to two XMIs.

DMI Description

The UBS Macro BTS frame must be equipped with at least one instance of the DMI. A second DMI is optional. The DMIs are located in the right side of the XMI shelf in the UBS Macro BTS frame (see [Figure 1-1 UBS Macro BTS low-tier/low-capacity frame \(1000 mm rack\) on page 1-27](#), [Figure 1-2 Low capacity UBS Macro BTS starter frame \(1800 mm rack\) on page 1-28](#) and [Figure 1-3 UBS Macro BTS mid-capacity frame \(1800 mm rack\) on page 1-30](#)). The DMIs are stacked vertically in an XMI shelf slot. DMI 1 is on the top and DMI 2 is on bottom. If the optional second DMI is not equipped, an empty DMI outer housing is in the DMI 2 position.

The DMI includes a DMI assembly that slides into a DMI outer housing. The DMI assembly consists of a chassis with a controller board, two rear mounted cooling fans and a front panel. The DMI assembly may also be equipped with up to two modem boards. When the UBS Macro BTS frame equipment is shipped from the factory the DMI assembly is equipped with at least one modem board. A second modem board is optional and may be either factory or field installed.

The DMI can be equipped with either 1X CDMA modem boards, EV-DO modem boards, or a combination of one 1X CDMA modem board and one EV-DO modem board.

Each modem board mounts on opposite sides of the controller board. Modem board-to-controller board electrical connection is via a printed circuit board mounted High Density Mezzanine (HDMEZZ) type connector. Each modem board is secured to the DMI assembly chassis with seven screws that are captivated to the modem board.

[Figure 8-1 Removing and installing Modem 1 on page 8-13](#) and [Figure 8-2 Removing and installing Modem 2 on page 8-14](#) show the locations of Modem 1 and Modem 2 within the DMI assembly.



NOTE

The following rules apply to modem board location within the DMI:

- For a DMI equipped with one 1X CDMA modem board, the 1X CDMA modem board is always Modem 1 location
- For a DMI equipped with one EV-DO modem board, the EV-DO modem board is always Modem 2 location
- For a DMI equipped with a combination of one 1X CDMA modem board and one EV-DO modem board, the 1X CDMA modem board is always Modem 1 location and the EV-DO modem board is always Modem 2 location

The DMI assembly is the FRU (i.e., spare) that is used for DMI replacement. This assembly includes a chassis with a controller board, fans, front panel and two modem boards. This assembly does not include an outer housing. The DMI outer housing in the UBS Macro BTS frame is reused.

The DMI FRU that is used for DMI replacement can be either of the following:

- Factory built DMI assembly – consisting of a DMI chassis, controller board, fans, front panel and two modem boards (i.e., 1X CDMA, EV-DO, or a combination of both).
- Field prepared DMI assembly – consisting of a DMI chassis, controller board, fans, front panel and up to two modem boards (i.e., 1X CDMA, EV-DO, or a combination of both) that are added to the assembly in the field.



NOTE

This chapter provides a procedure describing how to field prepare a DMI assembly, by installing up to two modems, so that it matches the configuration of the failed DMI.

The DMI assemblies do not include an outer housing. The DMI outer housing in the UBS Macro BTS frame is reused.

The typical DMI replacement scenario is as follows:

1. Remove the failed DMI assembly from its outer housing in the UBS Macro BTS frame.
2. Remove the replacement DMI assembly from its packaging and install it into the outer housing in the UBS Macro BTS frame.
3. Place the failed DMI assembly into the packaging that the replacement DMI came in.



NOTE

The DMI assembly FRU is used as a replacement for a DMI with an internal DMI component failure (including controller board, modem board, fan, or front panel failure). Although, a DMI with a modem board failure can just have the failed modem board replaced. This is covered in the Modem Board section of this chapter.



NOTE

This chapter also provides a procedure describing how to dismantle a failed DMI assembly in the field. This procedure is used if it is desired to reclaim known good FRUs from the failed DMI assembly. After dismantling the DMI assembly, the failed portion may be returned to Motorola for repair and the reclaimed known good FRUs may be restocked.

System impact/considerations



NOTE

If the UBS Macro BTS frame is equipped with one DMI, then performing this replacement procedure will cause BTS downtime and suspend all call processing .

If the UBS Macro BTS frame is equipped with two DMIs, then performing this replacement procedure for the Site Master DMI will temporarily cause BTS downtime. This is due to soft reset of the non-Site Master DMI during the DMI swap procedure. As soon as the DMI swap procedure is finished, the non-Site Master DMI becomes the Site Master DMI and call processing resources are available, but temporarily reduced until the failed DMI is replaced.

Performing this replacement procedure for a non-Site Master DMI will not cause BTS downtime, but call processing resources will be temporarily reduced until the failed DMI is replaced.

Call traffic processing through the site will be temporarily interrupted by the DMI replacement procedure.

Alarms will be generated during the DMI replacement procedure.

The DMI is not hot swappable.

DMI removal requires shutting down DC power to the DMI as well as disconnection of all DMI cables.

Table 8-1 DMI Replacement Conditions

FRU	Ref Designator	What to Shutdown...
Digital Module Internal	DMI	From the OMCR, lock the DMI being removed. Then shut down the DMI DC input power.

Required items

Documents

- *1X UBS Macro BTS Optimization/ATP* manual.

Tools

- T20 TORX bit.
- Torque driver.
- ESD wrist straps.
- ESD floor and bench top mats.
- ESD containers.

Replacement Units



NOTE

All models of DMI assemblies include: DMI chassis with controller board, fans and front panel.

Factory built DMI assemblies:

- DMI assembly with one 1X CDMA modem board (Motorola model STLN6681).
- DMI assembly with one EV-DO modem board (Motorola model STLN6682).
- DMI assembly with two 1X CDMA modem boards (Motorola model STLN6683).
- DMI assembly with one 1X CDMA modem board and one EV-DO modem board (Motorola model STLN6684).
- DMI assembly with two EV-DO modem boards (Motorola model STLN6679).

— **OR** —

Field prepared DMI assembly consisting of:

- DMI assembly without modem boards (Motorola model STLN6325). Up to two modem boards are added to the assembly in the field. Add the appropriate quantities of the following:
 - c CDMA 1X Modem Board (Motorola model SGLN6336).
- **AND/OR** —
- c EV-DO Modem Board (Motorola model SGLN6494).

DMI I/O Panel Connectors/Ports & LEDs

DMI I/O Panel

Figure 1-11 DMI Module Front Panel Detail on page 1-41 shows I/O connectors on the front panel of the UBS Macro BTS DMI. The top-to-bottom positioning of the DMI shown in the figure is the same as when it is installed in the rack. This figure shows connector/port locations, connector types and brief cabling details.

DMI Connectors/Ports

The following text describes each connector/port on the DMI front panel.

- **+27VDC** - DMI DC input power connections. Connects to corresponding DMI DC power connector on the PDU of the UBS Macro BTS frame. The PDU DMI DC power connector supplies protected +27 V via a 20 A circuit breaker.
- **IDI/SSI 1** and **SSI 2** - Serial backhaul traffic and control data connectors provide serial data links between the DMI and the corresponding SSIs. The SSI 2 port is currently not used.



NOTE

The R20 UBS Macro BTS does not support frame configurations with an IDI (Interworking DMI Interconnect) application.

- **XMI 1/BSI** and **XMI 2** - High-speed Serial data Link (HSL) port connectors that each provide a 1.2288 Gbps high-speed serial data links between the DMI and the respective XMI. The high-speed serial data links support the transfer of baseband I & Q data as well as control data between the DMI and XMI. These connectors are cabled to the appropriate HSL 1 or HSL 2 high-speed serial data link connector on the XMI front I/O panel.



NOTE

The R20 UBS Macro BTS does not support frame configurations with a BSI (Baseband Switch Interface) application.



CAUTION

The MMI and LMT ports are intended to be used primarily for testing or debugging purposes by Motorola. These ports may be used in the field for maintenance purposes by customers. Carefully follow written procedures when using these ports in the field. Failure to do so could result in an inoperable FRU.

- **RS232-1** and **RS232-2** - Debug RS-232 ports allow MMI access to the DMI controller board via a computer terminal through either a modem or a null modem cable. These MMI ports are 8-pin RJ-45 connectors.
- **LMT** and **TEST** - These ports are intended for development use only. These debug ports are configured for full-duplex fast Ethernet 10/100BaseT and allows local MMI access to the DMI controller board via a Local Maintenance Terminal (LMT) with an Ethernet interface. The LMT and TEST ports are 8-pin RJ-45 connectors.

DMI LEDs

Table 8-2 shows the possible states for the DMI front panel LEDs and the corresponding indications. These LED indicators are located on the DMI front panel next to the DMI +27 V DC connector (see [Figure 1-11 DMI Module Front Panel Detail on page 1-41](#)) and are labeled as follows:

- **ALM** (ALARM)
- **INST** (INSTANCE)
- **ST** (STATUS)

Table 8-2 DMI LEDs States and Indications

ALM (Red) LED State	INST LED State	STA (Green) LED State	Indication
Off	Off	Off	No DC Power to FRU
On	Orange	On	LED Indicator Test (temporary; 0.5 sec to 1 sec)
On	N/A	Off	FRU Failure
Off	N/A	N/A	No FRU Failure
Flashing (1.5 sec-On/1 sec-Off)	N/A	N/A	Partial (soft) FRU Failure
N/A	N/A	Flashing (250 ms-On/250 ms-Off)	FRU Booting up (not active)
N/A	N/A	On	FRU Active
N/A	Green Flashing (0.5 sec-On/0.5 sec-Off cycle count) followed by 3 sec-Off	N/A	Instance Indicator and No FRU Cabling Connection Errors Detected. Cycle count equals FRU type instance; where: 1 flash = 1st instance, 2 flashes = 2nd instance, 3 flashes = 3rd instance, so on and so forth.
N/A	Red	N/A	FRU Cabling Connection Error Detected

N/A = LED state is Not Applicable to indication

Prerequisites



CAUTION

ESD handling precautions **must be** adhered to when handling and working on the DMI assembly or the modem boards. Wear a conductive, high impedance wrist strap during handling. All work performed on the DMI assembly and modem boards **must be** done in an ESD protected work area.

The procedures in this chapter requires working on or around circuitry that is extremely sensitive to ESD.



NOTE

Coordinate the DMI replacement task with the OMCR operator.

Before You Begin

Before you begin, record the pertinent information in the following table (see [Table 8-3](#)):

Table 8-3 Item Number Replacement List

Item	Number
BTS number	
DMI number	

If the failed DMI is to be replaced with a “field prepared DMI assembly”, it will be necessary to have a work area that meets the criteria described in [DMI Preparation Area on page 8-10](#). Then it will be necessary to prepare the complete DMI assembly by performing [Procedure 8-1 Preparing the replacement DMI assembly in the Field on page 8-11](#) prior to performing the [Procedure 8-2 Replacing the DMI on page 8-15](#).

DMI Preparation Area

The DMI preparation area should provide the following ESD protection and the proper environmental conditions.

- ESD Protection:
 - c Always wear a ground strap which must be connected to the electrostatic point on the equipment.
 - c Leave any conductive foam pieces on connectors or leads until the last moment. Remove these pieces just before installing the device.
 - c Do not wear outer clothing made of nylon or similar man made material. A cotton overall is preferable.
 - c If possible work on an grounded metal surface or anti-static mat. Wipe insulated plastic work surfaces with an anti-static cloth before starting the operation.
 - c All metal tools should be used and when not in use they should be placed on an grounded surface.
 - c Take care when removing components connected to electrostatic sensitive devices. These components may be providing protection to the device.
 - c When mounted onto printed circuit boards (PCBs), MOS devices are normally less susceptible to electrostatic damage. However PCBs should be handled with care, preferably by their edges and not by their tracks and pins, they should be transferred directly from their packing to the equipment (or the other way around) and never left exposed on the workbench.
- Proper Environmental Conditions:
 - c Preparation surface should be clean and dry.
 - c Preparation environment should be clean and dry and provide protection such that contaminants will not enter the equipment.
 - c Work environment should allow enough space and adequate lighting to accurately align components during assembly.

DMI Field Preparation Procedure

Perform [Procedure 8-1 Preparing the replacement DMI assembly in the Field on page 8-11](#) in the DMI preparation area. This procedure describes how to prepare a complete DMI assembly from spares inventory that matches the failed DMI assembly. Up to two modems may be installed into the DMI assembly. The following spares are required:

- DMI assembly without modem boards (Motorola model STLN6325) includes DMI chassis with controller board, fans and front panel.
 - CDMA 1X Modem Board (Motorola model SGLN6336); up to two modem boards as required.
- AND/OR —**
- EV-DO Modem Board (Motorola model SGLN6494); up to two modem boards as required.

Procedure 8-1 Preparing the replacement DMI assembly in the Field

AT THE OMCR	
1	<p>Ask the OMCR operator to get the EID information for the failed DMI by entering the following command at the prompt: <code>omc-000000>DISPLAY BTS-<bts#>- EID</code></p> <p>Observe the displayed response. Record the model number of the failed DMI and its modem board quantity and model numbers. Modem boards are designated as HDMODEM. Check values for both HDMODEM numbers (i.e., 1, 2 for DMI 1 and 21, 22 for DMI 2) on the affected DMI. If an HDMODEM number has a blank value, then it does not exist.</p>
IN THE DMI PREPARATION AREA	
2	Based on the failed DMI EID information, determine the quantity and type of modem boards needed to match that of the failed DMI.
3	Obtain the needed replacement units.
 <div style="display: inline-block; border: 1px solid black; background-color: yellow; padding: 2px 10px; margin-left: 10px;">CAUTION</div>	
<p>ESD handling precautions must be adhered to when handling and working on the DMI assembly or the modem boards. Wear a conductive, high impedance wrist strap during handling. All work performed on the DMI assembly and modem boards must be done in an ESD protected work area.</p>	
4	Remove the DMI assembly, without modems, from its shipping packaging. Set the DMI assembly handle side up (see Figure 8-1 Removing and installing Modem 1 on page 8-13) onto a clean, ESD protected surface. Retain the packaging for later reuse.
5	Remove the modem board(s) from its shipping packaging. Retain the packaging for later reuse.
6	<p>Install Modem 1 into the DMI assembly by performing the following:</p> <ol style="list-style-type: none"> 1. Carefully place the front edge of Modem 1 under the lip of the DMI front panel. 2. Align the modem-to-controller connector halves so that they will mate together. In order to ensure proper connector alignment prior to connector insertion, verify that the modem screws are aligned with chassis mounted standoffs and that screws are not at an angle. 3. Press down firmly on the black plastic modem connector handle until the connector halves are fully seated. Approximately 70 N (15 lbs) of force is required to fully seat the connector halves. 4. Using a T20 TORX bit and torque driver, tighten the seven captive screws that retain Modem 1 to the replacement DMI assembly. Tighten the screws to 1.6 - 1.8 N-m (14 - 16 in-lb). 5. After tightening the screws, firmly squeeze the modem connectors together to make sure that it is well seated. This may help prevent problems/errors that may not be visible from the OMCR.

Continued

Procedure 8-1 Preparing the replacement DMI assembly in the Field (Continued)

7	If the failed DMI assembly to be replace is equipped with Modem 2, go to step 8 otherwise go to step 11 .
8	Position the DMI assembly on its side with the front panel handle at the bottom (see Figure 8-2 Removing and installing Modem 2 on page 8-14).
9	Remove the modem board from its shipping packaging. Retain the packaging for later reuse.
10	<p>Install Modem 2 from the failed DMI assembly into the replacement DMI assembly by performing the following:</p> <ol style="list-style-type: none"> 1. Carefully place the Modem 2 in the rear half of the DMI assembly. 2. Align the modem-to-controller connector halves so that they will mate together. In order to ensure proper connector alignment prior to connector insertion, verify that the modem screws are aligned with chassis mounted standoffs and that screws are not at an angle. 3. Press down firmly on the black plastic modem connector handle until the connector halves are fully seated. Approximately 70 N (15 lbs) of force is required to fully seat the connector halves. 4. Using a T20 TORX bit and torque driver, tighten the seven captive screws that retain Modem 2 to the replacement DMI assembly. Tighten the screws to 1.6 - 1.8 N-m (14 - 16 in-lb). 5. After tightening the screws, firmly squeeze the modem connectors together to make sure that it is well seated. This may help prevent problems/errors that may not be visible from the OMCR.
11	<p>Place the field prepared DMI assembly, with modems, into the original packaging that the DMI assembly was received in.</p> <div style="display: flex; align-items: center; margin-top: 10px;">  <div style="background-color: #00FFFF; padding: 5px 10px; border: 1px solid black; font-weight: bold; color: black;">NOTE</div> </div> <p style="margin-top: 10px;">To speed up code and data synchronization when this replacement DMI is placed into the BTS (especially if it is the only DMI in the BTS), it is recommended to set up a staging area for upgrading the code and base file for this replacement DMI to the same version that is used at the site. Afterwards, the DMI may be packaged and taken to the site.</p>
12	Take the field prepared DMI assembly, in it's packaging, to the BTS site having the failed DMI. Perform Procedure 8-2 Replacing the DMI on page 8-15 .

Reference Diagrams

The following diagrams are used to aid the DMI replacement procedures.

Figure 8-1 shows the DMI assembly with its bottom side up for access to Modem 1.

Figure 8-1 Removing and installing Modem 1

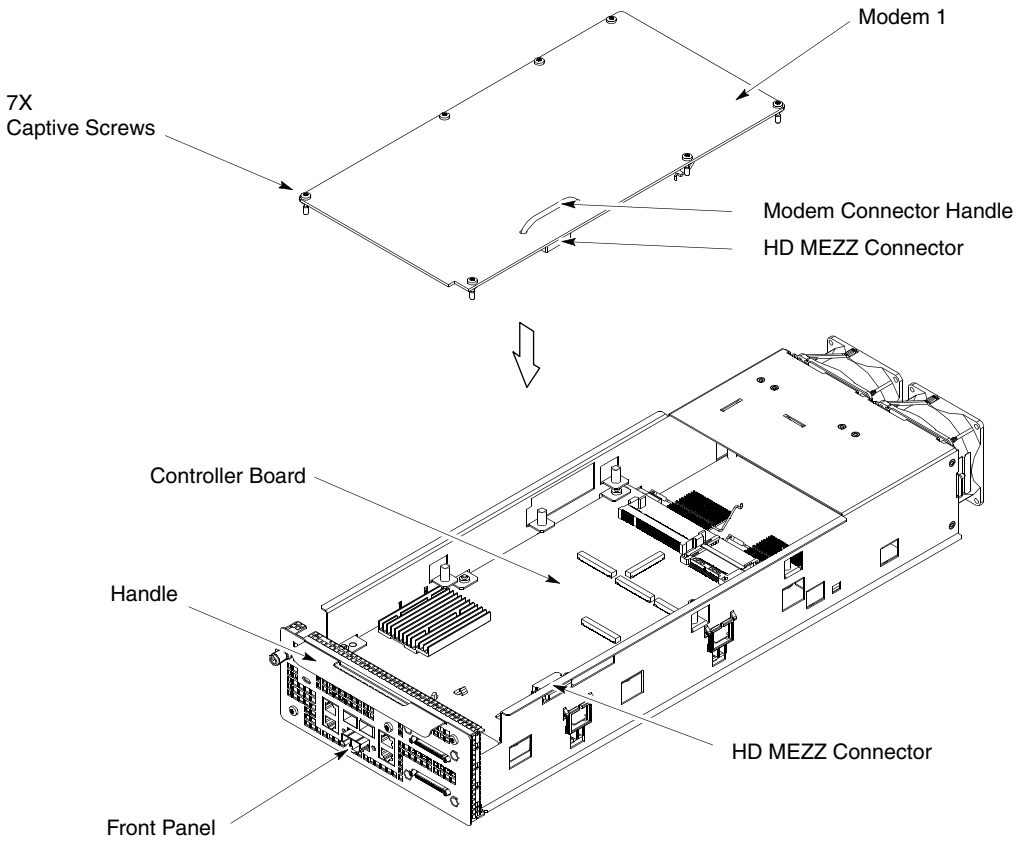

ti-cdma-06168.eps

Figure 8-2 shows the DMI assembly with its top side up for access to Modem 2.

Figure 8-2 Removing and installing Modem 2

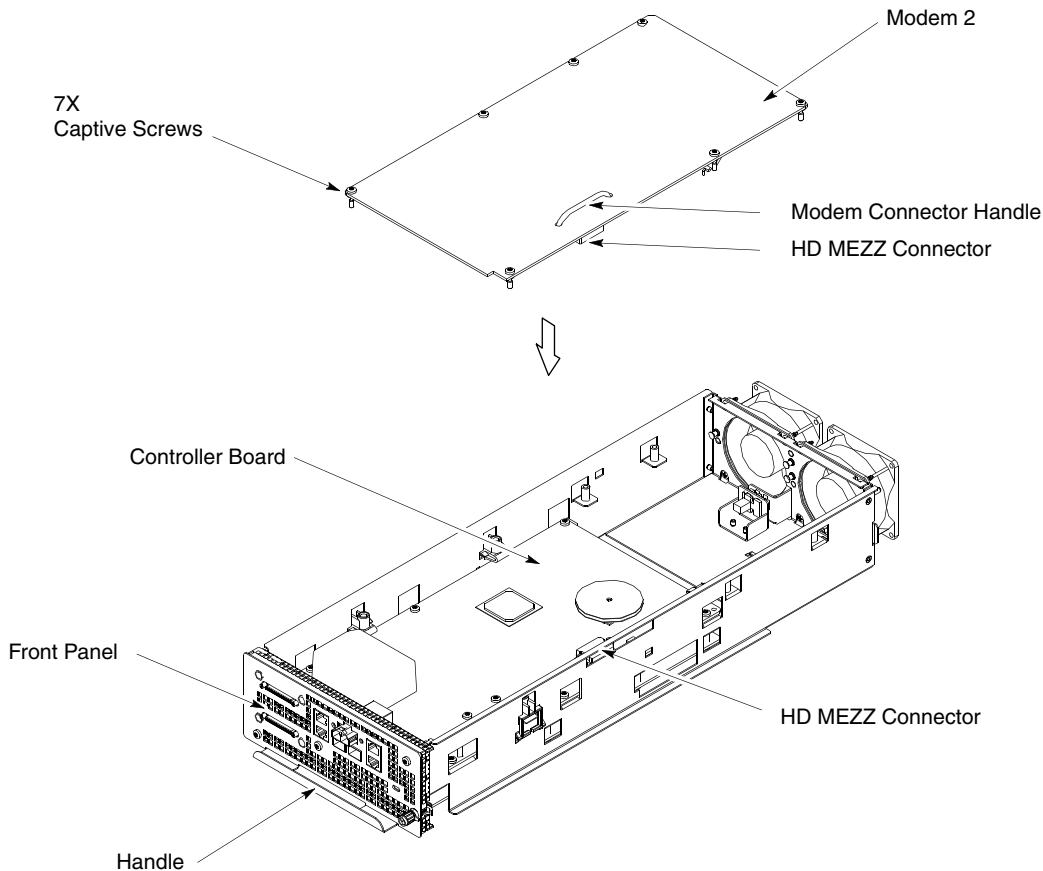

ti-cdma-06169.eps

DMI Replacement Procedure

Procedure 8-2 Replacing the DMI on page 8-15 includes:





1. Removing the failed DMI assembly from the UBS Macro BTS frame.
2. Removing the replacement DMI assembly from its packaging.
3. Installing the replacement DMI assembly, equipped with modems, into the UBS Macro BTS frame.

Procedure 8-2 Replacing the DMI

AT THE OMCR	
1	<p>If you have not already asked the OMCR operator to get the EID information for the failed DMI, then have the OMCR operator enter the following command at the prompt:</p> <pre>omc-000000>DISPLAY BTS-<bts#>- EID</pre> <p>Observe the displayed response. Record the model number of the failed DMI and its modem board quantity and model numbers. Modem boards are designated as HDMODEM. Check values for both HDMODEM numbers (i.e., 1, 2 for DMI 1 and 21, 22 for DMI 2) on the affected DMI. If an HDMODEM number has a blank value, then it does not exist.</p>
2	<p>For a UBS Macro BTS equipped with one DMI, go to step 3. For a UBS Macro BTS equipped with more than one DMI, go to step 4.</p>
3	<p>Shut down site signaling functions according to Procedure 3-2 Shutdown site signaling functions procedure for a packet BTS on page 3-5. After this step is completed, go to step 8.</p>
4	<p>Determine if the failed DMI is the Site Master or not by entering the following command at the prompt:</p> <pre>omc-000000>STATUS DMI-<bts#>-<dmi#>- PHY</pre> <p>Observe the displayed response. SITECTRL=YES means the DMI is Site Master. SITECTRL=NO means the DMI is not Site Master.</p>
5	<p>For a failed DMI that <i>is</i> the Site Master, go to step 6. For a failed DMI that <i>is not</i> the Site Master, go to step 7.</p>
6	<p>Reset the failed DMI Site Master and force the other DMI to become the Site Master by entering the following command at the prompt:</p> <pre>omc-000000>RESET DMI-<bts#>-<dmi#>- UNC</pre>
7	<p>Lock the failed DMI by entering the following command at the prompt:</p> <pre>omc-000000>LOCK DMI-<bts#>-<dmi#>- UNC</pre>
AT THE BTS SITE	
8	<p>Based on the failed DMI EID information, determine the type of DMI that matches the failed DMI.</p>
9	<p>Obtain the needed replacement DMI.</p>
10	<p>Set the replacement DMI assembly, in its packaging, near the UBS Macro BTS frame.</p>

Continued

Procedure 8-2 Replacing the DMI (Continued)

11	<p>Power down the failed DMI by setting the corresponding PDU DMI 20A circuit breaker to the off position (pulled out).</p> <div style="display: flex; align-items: center;">  <div style="margin-left: 10px;"> <div style="border: 1px solid black; background-color: yellow; padding: 2px 5px; display: inline-block;">CAUTION</div> <p>Make sure the PDU DMI circuit breaker is set to OFF.</p> </div> </div>
	<div style="display: flex; align-items: center;">  <div style="margin-left: 10px;"> <div style="border: 1px solid black; background-color: cyan; padding: 2px 5px; display: inline-block;">NOTE</div> <p>You will be disconnecting multiple cables from connectors. If necessary, use masking tape and a marker and temporarily tag each cable as to the proper connector before disconnection.</p> </div> </div>
12	<div style="display: flex; align-items: center;">  <div style="margin-left: 10px;"> <div style="border: 1px solid black; background-color: yellow; padding: 2px 5px; display: inline-block;">CAUTION</div> <p>ESD handling precautions must be adhered to during this procedure. Wear a conductive, high impedance wrist strap.</p> <p>Plug the end of the ESD wrist strap into the UBS Macro BTS frame ESD jack This jack is located in the middle of the upper XMI shelf bracket. Attach the wrist strap to your wrist.</p> </div> </div>
13	<p>Disconnect all of the cables connected to the front panel connectors on the failed DMI.</p>
14	<p>Turn the retaining fastener, located in the upper right corner of the failed DMI front panel, CCW (Counter Clockwise) until resistance is felt. This indicates that the retaining fastener is disengaged.</p>
15	<p>Grasp the failed DMI by the handle with one hand and pull outward. While supporting the bottom of the DMI assembly with the other hand, slide the failed DMI assembly completely out of its housing.</p>
16	<div style="display: flex; align-items: center;">  <div style="margin-left: 10px;"> <div style="border: 1px solid black; background-color: yellow; padding: 2px 5px; display: inline-block;">CAUTION</div> <p>ESD handling precautions must be adhered to when handling the DMI assembly.</p> <p>Set the failed DMI assembly onto a clean, ESD protected surface.</p> </div> </div>
17	<p>Remove the replacement DMI assembly from its packaging.</p>

Continued

Procedure 8-2 Replacing the DMI (Continued)

18	Install the replacement DMI assembly, with modems, into the appropriate empty DMI housing in the UBS Macro BTS frame by performing the following: <ol style="list-style-type: none"> 1. Position the replacement DMI assembly on its bottom edge so that the front panel handle is on the right and the retaining fastener is at the top. 2. Pick up the replacement DMI assembly with two hands. 3. Insert the rear of the replacement DMI assembly into the empty housing. 4. Slide the replacement DMI assembly completely into the housing. 5. Turn the retaining fastener CW (Clockwise) until finger tight to secure the DMI assembly in the housing.
19	Place the failed DMI assembly, with modems, into the packaging that the replacement DMI assembly came in.
20	Reconnect all of the cables to the corresponding connectors on the DMI front panel.
21	Power up the DMI by setting the corresponding PDU DMI 20A circuit breaker to the on position (pushed in).

AT THE OMCR

22	For a UBS Macro BTS equipped with one DMI, go to step 23 . For a UBS Macro BTS equipped with more than one DMI, go to step 24 .
23	Restore site signaling operations according to Procedure 3-3 Restore site signaling operations procedure for a packet BTS on page 3-10 . After this step is completed, go to step 25 .
24	Unlock the replacement DMI by entering the following command at the prompt: <code>omc-000000>UNLOCK DMI-<bts#>-<dm#>- UNC.</code>

AT THE BTS SITE

25	Perform the recommended optimization and testing on the UBS Macro BTS frame (see Optimization Recommended on page 8-17).
26	Remove the failed DMI assembly, in its packaging, from the BTS site and do either of the following: <ul style="list-style-type: none"> • Transport it to the DMI Preparation Area for dismantling (see Dismantling the failed DMI assembly in the Field on page 8-18). • Return it to Motorola for repair.

Optimization Recommended

Perform the following BTS Optimization/ATP procedures:

- BTS Device Database Audit
- BTS Device Database Update
- Timing Initialization/Verification
- TX Path Calibration Audit
- Spectral Purity TX Mask ATP (optional)
- Waveform Quality (Rho) ATP (optional)
- Code Domain Power ATP (optional)
- FER Test
- Alarm Verification

Refer to the *1X UBS Macro BTS Optimization/ATP* manual for the optimization procedures.

Dismantling the failed DMI assembly in the Field

Perform [Procedure 8-3 Dismantling the failed DMI assembly in the Field on page 8-18](#) only if it is desired to reclaim known good FRUs from the failed DMI assembly. This procedure must be performed in a work area that meets the criteria described in [DMI Preparation Area on page 8-10](#).

Procedure 8-3 Dismantling the failed DMI assembly in the Field

IN THE DMI PREPARATION AREA



CAUTION

ESD handling precautions **must be** adhered to when handling and working on the DMI assembly or the modem boards. Wear a conductive, high impedance wrist strap during handling. All work performed on the DMI assembly and modem boards **must be** done in an ESD protected work area.

- | | |
|----------|--|
| 1 | Remove the failed DMI assembly, with modems, from its packaging. Set the DMI assembly handle side up (see Figure 8-1 Removing and installing Modem 1 on page 8-13) onto a clean, ESD protected surface. |
|----------|--|

Continued

Procedure 8-3 Dismantling the failed DMI assembly in the Field (Continued)

2	<p>Remove Modem 1 from the failed DMI assembly by performing the following:</p> <ol style="list-style-type: none"> 1. Use a T20 TORX bit/driver to completely loosen the seven captive screws that retain Modem 1 to the failed DMI assembly. 2. Grasp the modem connector handle with one hand and hold the assembly down with the other hand. 3. Pull up on the modem connector handle until the modem-to-controller connector disengages. 4. Carefully lift Modem 1 out of the failed DMI assembly. 5. Place Modem 1 in the packaging that the replacement modem came in. 6. If this modem is the failed module, return it to Motorola for repair, otherwise return it to stock.
3	If the failed DMI assembly is equipped with Modem 2, go to step 4 otherwise go to step 6 .
4	With the failed DMI assembly sitting on the clean ESD protected surface, turn the assembly over so that the front panel handle is at the bottom (see Figure 8-2 Removing and installing Modem 2 on page 8-14).
5	<p>Remove Modem 2 from the failed DMI assembly by performing the following:</p> <ol style="list-style-type: none"> 1. Use a T20 TORX bit/driver to completely loosen the seven captive screws that retain Modem 2 to the failed DMI assembly. 2. Grasp the modem connector handle with one hand and hold the assembly down with the other hand. 3. Pull up on the modem connector handle until the modem-to-controller connector disengages. 4. Carefully lift Modem 2 out of the DMI assembly. 5. Place Modem 2 in the packaging that the replacement modem came in. 6. If this modem is the failed module, return it to Motorola for repair, otherwise return it to stock.
6	Place the dismantled DMI assembly, without modems, into the packaging that the replacement DMI assembly came in.
7	If the dismantled DMI assembly is the failed module, return it to Motorola for repair, otherwise return it to stock.

Modem Boards



NOTE

The R20 UBS Macro BTS supports frame configurations with DMIs having up to two modem boards that can be either 1X CDMA modem, EV-DO modem, or one of each.

1X Modem Board Description

The UBS Macro BTS frame DMIs may be equipped with up to two modem boards maximum. These modem boards can be either 1X CDMA modem, EV-DO modem, or one of each.

The DMIs are located in the right side of the XMI shelf in the UBS Macro BTS frame (see [Figure 1-1 UBS Macro BTS low-tier/low-capacity frame \(1000 mm rack\) on page 1-27](#), [Figure 1-2 Low capacity UBS Macro BTS starter frame \(1800 mm rack\) on page 1-28](#) and [Figure 1-3 UBS Macro BTS mid-capacity frame \(1800 mm rack\) on page 1-30](#)).

Each frame DMI includes a DMI assembly that slides into a DMI outer housing. The frame version DMI assembly consists of a chassis with a controller board, two rear mounted cooling fans, a front panel and up to two modem boards that can be either 1X CDMA modem, EV-DO modem, or one of each.

Each modem board mounts on opposite sides of the controller board. Modem board-to-controller board electrical connection is via a printed circuit board mounted High Density Mezzanine (HDMEZZ) type connector. Each modem board is secured to the DMI assembly chassis with seven screws that are captivated to the modem board.

[Figure 8-3 Removing and installing Modem 1 on page 8-28](#) and [Figure 8-4 Removing and installing Modem 2 on page 8-29](#) show the locations of Modem 1 and Modem 2 within the DMI assembly.



NOTE

The following rules apply to modem board location within the DMI:

- For a DMI equipped with one 1X CDMA modem board, the 1X CDMA modem board is always Modem 1 location
- For a DMI equipped with one EV-DO modem board, the EV-DO modem board is always Modem 2 location
- For a DMI equipped with a combination of one 1X CDMA modem board and one EV-DO modem board, the 1X CDMA modem board is always Modem 1 location and the EV-DO modem board is always Modem 2 location

The modem replacement scenario is as follows:

1. Remove the affected DMI assembly from the DMI outer housing located in the UBS Macro BTS frame.
2. Replace Modem 1 or Modem 2, whichever is applicable, in the affected DMI assembly.
3. Install the affected DMI assembly equipped with the replacement modem into the DMI outer housing located in the UBS Macro BTS frame.

System impact/considerations



NOTE

If the UBS Macro BTS frame is equipped with one DMI, then performing this replacement procedure will cause BTS downtime and suspend all call processing .

If the UBS Macro BTS frame is equipped with two DMIs, then performing this replacement procedure for the Site Master DMI will temporarily cause BTS downtime. This is due to soft reset of the non-Site Master DMI during the DMI swap procedure. As soon as the DMI swap procedure is finished, the non-Site Master DMI becomes the Site Master DMI and call processing resources are available, but temporarily reduced until the failed DMI is replaced.

Performing this replacement procedure for a non-Site Master DMI will not cause BTS downtime, but call processing resources will be temporarily reduced until the failed DMI is replaced.

The affected DMI assembly must be removed from the UBS Macro BTS frame.

Call traffic processing through the site will be temporarily interrupted by the modem board replacement procedure.

Alarms will be generated during the modem board replacement procedure.

The DMI is not hot swappable.

DMI removal requires shutting down DC power to the DMI as well as disconnection of all DMI cables.

All call traffic processing through the site will be interrupted by the DMI removal.

Table 8-4 Modem Board Replacement Conditions

FRU	Ref Designator	What to Shutdown...
1X Modem Board	Modem 1 or Modem 2	From the OMCR, lock the affected DMI being removed. Then shut down the DMI DC input power.

Required items

Documents

- *1X UBS Macro BTS Optimization/ATP* manual.

Tools

- T20 TORX bit.
- Torque driver.
- ESD wrist straps.
- ESD floor and bench top mats.
- ESD containers.

Replacement Units

- CDMA 1X Modem Board (Motorola model SGLN6336).
— *OR* —
- EV-DO Modem Board (Motorola model SGLN6494).

Prerequisites



CAUTION

ESD handling precautions **must be** adhered to when handling and working on the DMI assembly or the modem boards. Wear a conductive, high impedance wrist strap during handling. All work performed on the DMI assembly and modem boards **must be** done in an ESD protected work area.

The procedures in this chapter requires working on or around circuitry that is extremely sensitive to ESD.



NOTE

Coordinate this repair task with the OMCR operator.

Before You Begin

Before you begin, record the pertinent information in the following table (see [Table 8-5](#)):

Table 8-5 Item Number Replacement List

Item	Number
BTS number	
DMI number	
Modem number	

Much of the modem board replacement procedure must be performed in a work area that meets the criteria described in [DMI Preparation Area on page 8-10](#).

Modem Board Replacement Procedure

[Procedure 8-4 Replacing a Modem Board on page 8-23](#) includes:

1. Removing the affected DMI assembly from the UBS Macro BTS frame.
2. Replacing Modem 1 or Modem 2, whichever is applicable, in the affected DMI assembly.
3. Installing the affected DMI assembly equipped with the replacement modem into the UBS Macro BTS frame.

Procedure 8-4 Replacing a Modem Board



AT THE OMCR	
1	Ask the OMCR operator to get the EID information for the affected DMI by entering the following command at the prompt: <pre>omc-000000>DISPLAY BTS-<bts#>- EID</pre> Observe the displayed response. Record the model number of the failed DMI and its modem board quantity and model numbers. Modem boards are designated as HDMODEM. Check values for both HDMODEM numbers (i.e., 1, 2 for DMI 1 and 21, 22 for DMI 2) on the affected DMI. If an HDMODEM number has a blank value, then it does not exist.
2	For a UBS Macro BTS equipped with one DMI, go to step 3 . For a UBS Macro BTS equipped with more than one DMI, go to step 4 .
3	Shut down site signaling functions according to Procedure 3-2 Shutdown site signaling functions procedure for a packet BTS on page 3-5 . After this step is completed, go to step 8 .
4	Determine if the affected DMI is the Site Master or not by entering the following command at the prompt: <pre>omc-000000>STATUS DMI-<bts#>-<dmi#>- PHY</pre> Observe the displayed response. SITECTRL=YES means the DMI is Site Master. SITECTRL=NO means the DMI is not Site Master.

Continued

Procedure 8-4 Replacing a Modem Board (Continued)



5	For an affected DMI that <i>is</i> the Site Master, go to step 6 For an affected DMI that <i>is not</i> the Site Master, go to step 7 .
6	Reset the affected DMI Site Master and force the other DMI to become the Site Master by entering the following command at the prompt: <code>omc-000000>RESET DMI-<bts#>-<dmi#>- UNC</code>
7	Lock the affected DMI by entering the following command at the prompt: <code>omc-000000>LOCK DMI-<bts#>-<dmi#>- UNC</code>

AT THE BTS SITE

8	Based on the affected DMI EID information, determine the type (i.e., 1X CDMA or EV-DO) of failed modem board in the affected DMI.
9	Obtain the needed replacement modem board and keep it in an ESD container. Also obtain an ESD container to put the DMI assembly in.
10	Power down the affected DMI by setting the corresponding PDU DMI 20A circuit breaker to the off position (pulled out). <div style="display: flex; align-items: center; margin-top: 10px;">  <div style="border: 1px solid black; background-color: yellow; padding: 2px 5px; font-weight: bold; margin-right: 10px;">CAUTION</div> <p style="margin: 0;">Make sure the PDU DMI circuit breaker is set to OFF.</p> </div>
11	<div style="display: flex; align-items: center; margin-top: 10px;">  <div style="border: 1px solid black; background-color: cyan; padding: 2px 5px; font-weight: bold; margin-right: 10px;">NOTE</div> <p style="margin: 0;">You will be disconnecting multiple cables from connectors. If necessary, use masking tape and a marker and temporarily tag each cable as to the proper connector before disconnection.</p> </div>
11	<div style="display: flex; align-items: center; margin-top: 10px;">  <div style="border: 1px solid black; background-color: yellow; padding: 2px 5px; font-weight: bold; margin-right: 10px;">CAUTION</div> <p style="margin: 0;">ESD handling precautions <i>must be</i> adhered to during this procedure. Wear a conductive, high impedance wrist strap.</p> <p style="margin: 0;">Plug the end of the ESD wrist strap into the UBS Macro BTS frame ESD jack This jack is located in the middle of the upper XMI shelf bracket. Attach the wrist strap to your wrist.</p> </div>
12	Disconnect all of the cables connected to the affected DMI front panel connectors.
13	Turn the retaining fastener, located in the upper right corner of the affected DMI front panel, CCW (Counter Clockwise) until resistance is felt. This indicates that the retaining fastener is disengaged.
14	Grasp the affected DMI by the handle with one hand and pull outward. While supporting the bottom of the DMI assembly with the other hand, slide the DMI assembly completely out of its housing.

Continued

Procedure 8-4 Replacing a Modem Board (Continued)

15	 <div style="display: inline-block; border: 1px solid black; background-color: yellow; padding: 2px 5px; margin-left: 10px;">CAUTION</div> <p>ESD handling precautions must be adhered to when handling the DMI assembly.</p> <p>Place the affected DMI assembly into an ESD container.</p>
16	Transport the affected DMI assembly in its ESD container and the needed replacement modem board in its ESD container to the DMI preparation area.
IN THE DMI PREPARATION AREA	
17	 <div style="display: inline-block; border: 1px solid black; background-color: yellow; padding: 2px 5px; margin-left: 10px;">CAUTION</div> <p>ESD handling precautions must be adhered to when handling and working on the DMI assembly or the modem boards. All work performed on the DMI assembly and modem boards must be done in an ESD protected work area.</p> <p>Set the affected DMI assembly in its ESD container and the replacement modem board in its ESD container onto a clean, ESD protected surface.</p>
18	Remove the DMI assembly and the replacement modem board from the ESD containers. Retain the ESD containers for later reuse.
19	If replacing Modem 1, go to step 20 . If replacing Modem 2, go to step 24 .
20	Position the DMI assembly on its side with the front panel handle at the top (see Figure 8-3).
21	Remove Modem 1 from the DMI assembly by performing the following: <ol style="list-style-type: none"> 1. Use a T20 TORX bit/driver to completely loosen the seven captive screws that retain Modem 1 to the DMI assembly. 2. Grasp the modem extraction handle with one hand and hold the assembly down with the other hand. 3. Pull up on the modem extraction handle until the modem-to-controller connector disengages. 4. Carefully lift Modem 1 out of the DMI assembly.

Continued

Procedure 8-4 Replacing a Modem Board (Continued)

22	<p>Install the replacement modem board into Modem 1 position of the DMI assembly by performing the following:</p> <ol style="list-style-type: none"> 1. Carefully place the front edge of Modem 1 under the lip of the DMI front panel. 2. Align the modem-to-controller connector halves so that they will mate together. 3. Press down firmly on the modem just above the modem-to-controller connector until the connector halves are fully seated. 4. Using a T20 TORX bit and torque driver, tighten the seven captive screws that retain Modem 1 to the DMI assembly. Tighten the screws to 1.6 - 1.8 N-m (14 - 16 in-lb). 5. After tightening the screws, firmly squeeze the modem connectors together to make sure that it is well seated. This may help prevent problems/errors that may not be visible from the OMCR.
23	After Modem 1 is replaced, go to step 30 .
24	Position the DMI assembly on its side with the front panel handle at the bottom (see Figure 8-4).
25	<p>Remove Modem 2 from the DMI assembly by performing the following:</p> <ol style="list-style-type: none"> 1. Use a T20 TORX bit/driver to completely loosen the seven captive screws that retain Modem 2 to the DMI assembly. 2. Grasp the modem extraction handle with one hand and hold the assembly down with the other hand. 3. Pull up on the modem extraction handle until the modem-to-controller connector disengages. 4. Carefully lift Modem 2 out of the DMI assembly.
26	<p>Install the replacement modem board into Modem 2 position of the DMI assembly by performing the following:</p> <ol style="list-style-type: none"> 1. Carefully place the Modem 2 in the rear half of the DMI assembly. 2. Align the modem-to-controller connector halves so that they will mate together. 3. Press down firmly on the modem just above the modem-to-controller connector until the connector halves are fully seated. 4. Using a T20 TORX bit and torque driver, tighten the seven captive screws that retain Modem 2 to the DMI assembly. Tighten the screws to 1.6 - 1.8 N-m (14 - 16 in-lb). 5. After tightening the screws, firmly squeeze the modem connectors together to make sure that it is well seated. This may help prevent problems/errors that may not be visible from the OMCR.
27	Insert the DMI assembly and the failed modem board into ESD containers. Transport both of these items to the BTS site.

Continued

Procedure 8-4 Replacing a Modem Board (Continued)

AT THE BTS SITE	
28	 <div style="display: inline-block; border: 1px solid black; background-color: yellow; padding: 2px 5px; margin-left: 10px;">CAUTION</div> <p>ESD handling precautions must be adhered to when handling the DMI assembly.</p> <p>Plug the end of the ESD wrist strap into the UBS Macro BTS frame ESD jack. This jack is located in the middle of the upper XMI shelf bracket. Attach the wrist strap to your wrist.</p>
29	Remove the DMI assembly from the ESD container.
30	<p>Install the DMI assembly with replacement modem into its housing in the UBS Macro BTS frame by performing the following:</p> <ol style="list-style-type: none"> 1. Position the DMI assembly on bottom edge so that the front panel handle is on the right and the 1/4-turn retaining fastener is at the top. 2. Pick up the DMI assembly with two hands. 3. Insert the rear of the DMI assembly into its housing. 4. Slide the DMI assembly completely into the housing. 5. Turn the 1/4-turn retaining fastener one-quarter turn CW (Clockwise) to secure the DMI assembly in the housing.
31	Reconnect all of the cables to the corresponding connectors on the DMI front panel.
32	Power up the DMI by setting the corresponding PDU DMI 20A circuit breaker to the on position (pushed in).
AT THE OMCR	
33	For a UBS Macro BTS equipped with one DMI, go to step 34 . For a UBS Macro BTS equipped with more than one DMI, go to step 35 .
34	Restore site signaling operations according to Procedure 3-3 Restore site signaling operations procedure for a packet BTS on page 3-10 . After this step is completed, go to step 25 .
35	Unlock the affected DMI by entering the following command at the prompt: <code>omc-000000>UNLOCK DMI-<bts#>-<dmi#>- UNC</code>
AT THE BTS SITE	
36	Perform the recommended optimization and testing on the UBS Macro BTS frame (see Optimization Recommended on page 8-29).
37	Return the failed modem board in its ESD container to Motorola for repair.

Reference Diagrams

The following diagrams are used to aid the modem board replacement procedure.

Figure 8-3 shows the DMI assembly with its bottom side up for access to Modem 1.

Figure 8-3 Removing and installing Modem 1

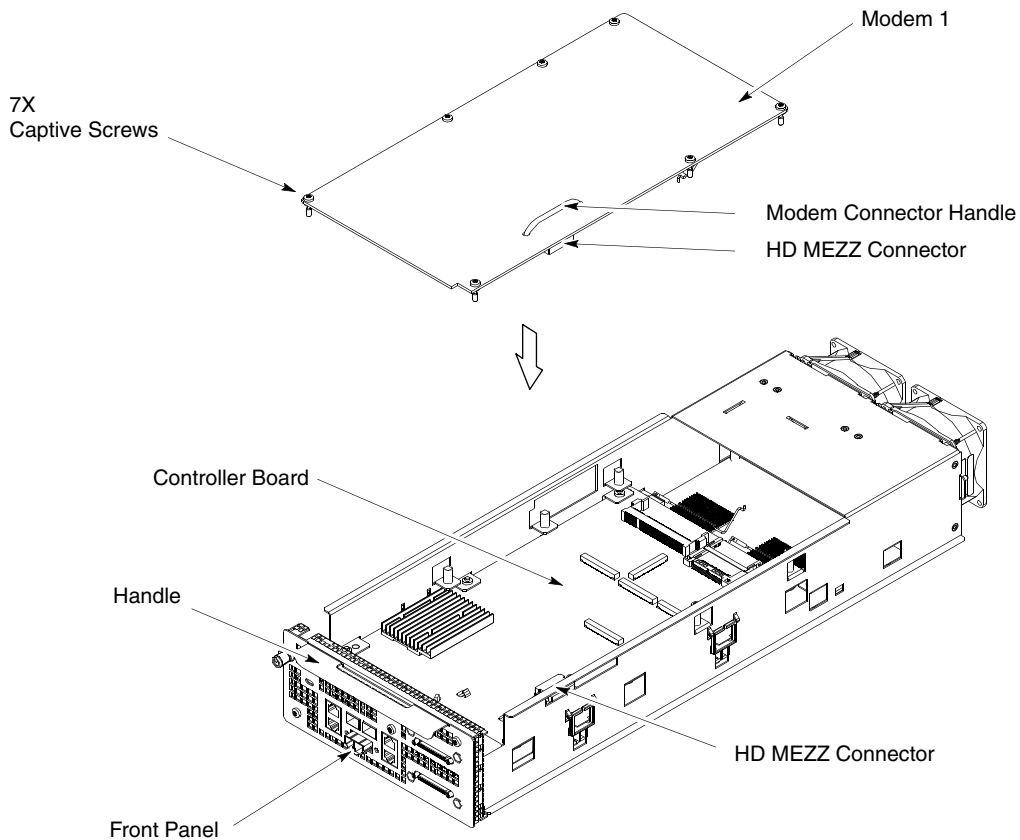

ti-cdma-06168.eps

Figure 8-4 shows the DMI assembly with its top side up for access to Modem 2.

Figure 8-4 Removing and installing Modem 2

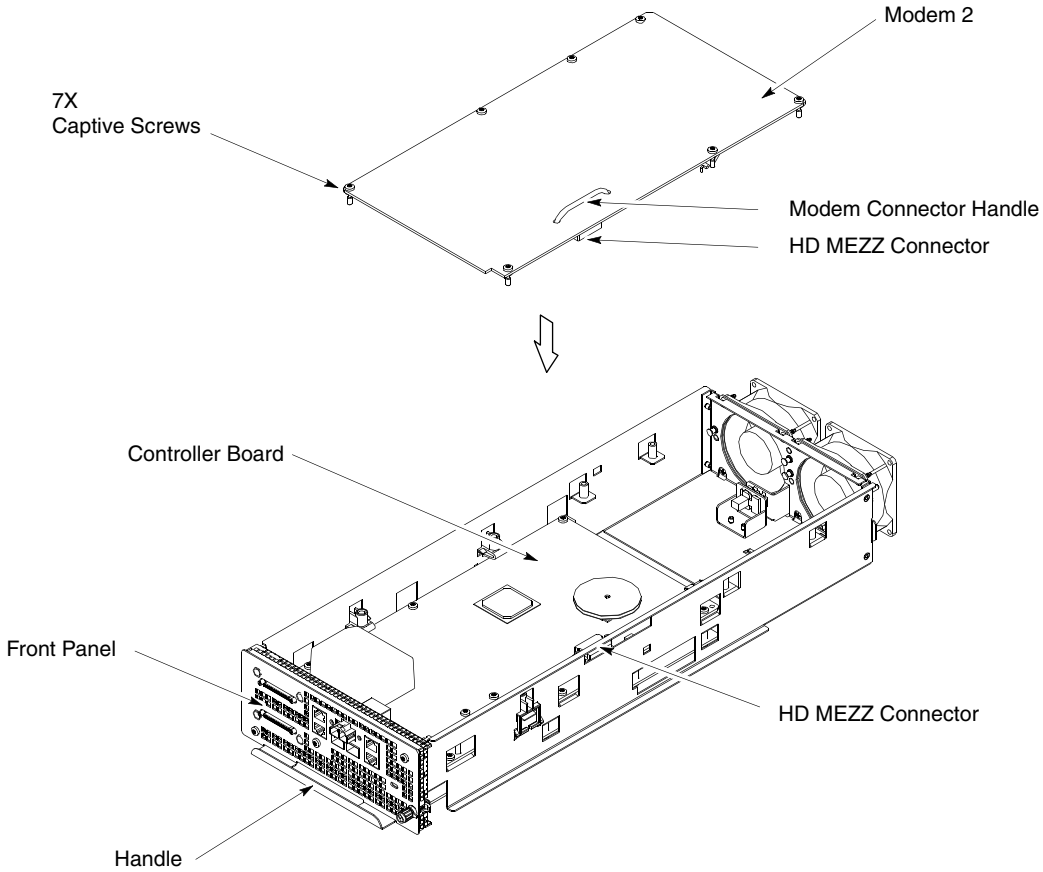

ti-cdma-06169.eps

Optimization Recommended

Perform the following BTS Optimization/ATP procedures:

- BTS Device Database Audit
- BTS Device Database Update
- Timing Initialization/Verification
- TX Path Calibration Audit
- Spectral Purity TX Mask ATP (optional)
- Waveform Quality (Rho) ATP (optional)
- Code Domain Power ATP (optional)
- FER Test
- Alarm Verification

Refer to the *1X UBS Macro BTS Optimization/ATP* manual for the optimization procedures.

PDU Replacement Procedures

Power Distribution Unit (PDU)

PDU Description

The PDU distributes +27 V DC output operating power to the UBS Macro BTS frame electronics.

The PDU is located near the bottom of the UBS Macro BTS frame. [Figure 1-1 UBS Macro BTS low-tier/low-capacity frame \(1000 mm rack\) on page 1-27](#), [Figure 1-2 Low capacity UBS Macro BTS starter frame \(1800 mm rack\) on page 1-28](#) and [Figure 1-3 UBS Macro BTS mid-capacity frame \(1800 mm rack\) on page 1-30](#) show the location of the PDU within the UBS Macro BTS frame.

[Figure 1-12 PDU front panel detail on page 1-42](#) shows the location of +27 V DC output power connectors and circuit breakers on the front of the PDU.

[Figure 1-13 PDU rear panel detail on page 1-43](#) shows the location of +27 V DC input power cable/connector and +27 V DC input filter capacitor on the rear of the PDU.

The PDU filters the +27 V DC input power and then splits the filtered +27 V DC input power into +27 V DC branch circuits. Each branch circuit may be equipped with an integrated circuit breaker and +27 V DC output power connector. Distribution is via output power cables connected between the PDU +27 V DC output power connectors and the corresponding equipment +27 V DC input power connector.

The circuit breakers provide current overload protection for the +27 V DC branch circuits distributed to the corresponding UBS Macro BTS equipment. The circuit breakers also provide ON/OFF switching of the +27 V DC output operating power to the corresponding equipment.



NOTE

The PDU is shipped with the 1st +27 V DC input power cable/connector and filter capacitor installed. The 2nd +27 V DC input power cable/connector and filter capacitor are installed, on site, when a 3rd XMI is added to the frame.



NOTE

The PDU is shipped with a circuit breaker and +27 V DC output power connector installed for: XMI 1, DMI 1, DMI 2 and SSI 1. When other equipment is added to the frame, the corresponding circuit breaker and +27 V DC output power connector is installed on site.

The PDU contains the following:

- Internal DC input reverse polarity/over-voltage/surge protection, filtering, input/output bus bars.
- Up to two DC input power cables/connectors for +27 V DC input to the rear of the PDU.
- PDU front panel with cutouts for integrated circuit breaker and +27 V DC output power connectors. There are cutouts for the following circuit breakers/power connectors:
 - Four 90A circuit breakers/power connectors for XMI 1 through XMI 4.
 - Five 20A circuit breakers/power connectors for DMI 1 through DMI 5.
 - Two 20A circuit breakers/power connectors for SSI 1 and SSI 2.
 - Two 10A circuit breakers/power connectors for ACC 1 and ACC 2. Each ACC branch circuit has three DC power connectors. Up to three accessories can share the 10A branch circuit.

System impact/considerations



NOTE

Performing this replacement procedure will cause BTS downtime and interrupt all call processing.

Prior to replacing the PDU, the UBS Macro BTS site signaling is shutdown (i.e., disable the BTS site) then the UBS Macro BTS frame is powered down.

Table 9-1 PDU Replacement Conditions

FRU	Ref Designator	What to Shutdown...
Power Distribution Unit (PDU)	PDU	Shutdown site signaling functions and then power down the frame.

Required items

Documents

- *1X UBS Macro BTS Optimization/ATP* manual.

Tools

- 10 mm socket and ratchet
- Torque driver
- T25 TORX driver

Torque requirements

- PDU mounting screws; 4.77 N-m (42 in-lb)

Replacement unit

- PDU (Motorola model STPN4038)

Prerequisites



NOTE

Coordinate this repair task with the OMCR operator.

Before you begin

Before you begin, record the pertinent information in [Table 9-2](#).

Table 9-2 Item number replacement list

Item	Number
BTS number	
Failed PDU	

PDU replacement procedure





CAUTION

This procedure requires working on or around circuitry which is extremely sensitive to ESD. Wear a conductive, high impedance wrist strap during the procedure. Use appropriate safety measures.

To replace the PDU perform [Procedure 9-1](#) and then [Procedure 9-2](#).

Procedure 9-1 Removing the failed PDU

AT THE OMCR	
1	Shut down site signaling functions according to Procedure 3-2 Shutdown site signaling functions procedure for a packet BTS on page 3-5 .
AT THE BTS SITE	
2	Power down the UBS Macro BTS frame according to the section: Powering Down the Frame on page 2-3 .
	<div style="display: flex; align-items: center;">  <div style="margin-left: 10px;"> <p style="background-color: yellow; border: 1px solid black; padding: 2px; display: inline-block;">CAUTION</p> <p>Make sure the facility circuit breaker controlling external AC or DC power, whichever is applicable, to the UBS Macro BTS frame is set to the OFF position.</p> </div> </div>
	<div style="display: flex; align-items: center;">  <div style="margin-left: 10px;"> <p style="background-color: cyan; border: 1px solid black; padding: 2px; display: inline-block;">NOTE</p> <p>You will be disconnecting multiple cables from connectors. If necessary, use masking tape and a marker and temporarily tag each cable as to the proper connector before disconnection.</p> </div> </div>
3	Disconnect the +27 V DC output power cable from the +27 V DC input power cable on the rear of the PDU by separating the orange connectors.
4	Disconnect all of the cables connected to the PDU front panel connectors.
5	If UBS Macro BTS frame is equipped with carrier strips go to step 6 . If UBS Macro BTS frame is not equipped with carrier strips go to step 7 .
6	Remove the carrier strips from the frame as follows: <ul style="list-style-type: none"> • Using a 10 mm socket and ratchet, loosen and remove the 8 nuts that secure each carrier strip to the frame. • Remove the carrier strip.
7	Loosen the two rack mounting screws in the keyhole slots of the PDU rack mounting flanges. Do not remove these two screws. Leave the screw heads extending 8 mm out from the rack surface. These two screws will serve as hanger screws.
8	Completely loosen and remove the remaining two rack mounting screws in the PDU rack mounting flanges.
9	Grasp the PDU and lift it up and off of the hanger screws. Pull the PDU out of the rack and set it out of the way.

Procedure 9-2 Installing the replacement PDU**AT THE BTS SITE**

1	Properly position the replacement PDU in the rack location. Align the keyhole slots of the PDU mounting flanges with the two hanger screws and hang the replacement PDU on the rack.
2	Insert screws in the two open slots of the PDU rack mounting flanges. Tighten all four PDU rack mounting screws to 4.77 N-m (42 in-lb).
3	Reconnect all applicable cables to the PDU front panel connectors.
4	Connect the +27 V DC output power cable to the +27 V DC input power cable on the rear of the PDU by mating the orange connectors.
5	Power up the UBS Macro BTS frame according to the section: Power-up the Frame on page 2-3 .

**NOTE**

There is no optimization required for the PDU replacement.

AT THE OMCR

6	Restore site signaling operations according to Procedure 3-3 Restore site signaling operations procedure for a packet BTS on page 3-10 .
----------	--

Breaker Module Assembly (BMA)

BMA Description

The BMA is an integrated circuit breaker and output power connector. The circuit breaker provides current overload protection for the output power connector.

The BMAs are located on the PDU front panel (see [Figure 1-12 PDU front panel detail on page 1-42.](#))

The BMAs provide current overload protection for the +27 V DC branch circuits distributed to the corresponding UBS Macro BTS equipment. The circuit breakers also provide ON/OFF switching of the +27 V DC output operating power to the corresponding equipment.

The PDU in the UBS Macro BTS may be equipped with the following BMAs:

- up to four 90A for XMI 1 – XMI 4.
- up to five 20A for DMI 1 – DMI 5.
- up to two 20A for SSI 1 – SSI 2.
- up to two 10A for ACC 1 – ACC 2. This BMA has three output power connectors for accessories.



NOTE

The actual BMA equipage in the PDU is customer dependent.

Each BMA is arranged so that the circuit breaker is just below the corresponding DC output power connector.

The PDU front panel cover must be removed to gain access to the BMAs (see [Figure 9-1 PDU Front Panel Removal/Installation Detail on page 9-12.](#))

Each BMA is screw mounted to the PDU output bus bars (i.e., +27 V DC and –0 V DC). This physical mounting provides electrical contact between the bus bars and the BMA. Refer to [Figure 9-2 PDU Front Panel \(cover removed\) on page 9-12](#) for BMA screw mounting details.

System impact/considerations



NOTE

Performing this replacement procedure will cause BTS downtime and interrupt all call processing.

Prior to replacing a BMA, the UBS Macro BTS site signaling is shutdown (i.e., disable the BTS site) then the UBS Macro BTS frame is powered down.

Table 9-3 PDU Replacement Conditions

FRU	Ref Designator	What to Shutdown...
Breaker Module Assembly (BMA)	XMI 1 – XMI 4, DMI 1 – DMI 5, SSI 1 – SSI 2, ACC 1 – ACC 2	Shutdown site signaling functions and then power down the frame.

Required items

Documents

- *1X UBS Macro BTS Optimization/ATP* manual.

Tools

- Torque driver
- T25 TORX driver

Torque requirements

- BMA mounting screws; 4.8 N-m (42.25 in-lb) $\pm 10\%$

Replacement unit

- 90A BMA (Motorola model STLN4093), for XMIs
- 20A BMA (Motorola model STLN6472), for DMIs and SSIs
- 10A BMA (Motorola model STLN6475), for ACCs



NOTE

Mounting screws are provided with each BMA; four screws with the 90A BMA, two screws with the 20A BMA and two screws with the 10A BMA.

Prerequisites



NOTE

Coordinate this repair task with the OMCR operator.

Before you begin

Before you begin, record the pertinent information in [Table 9-4](#).

Table 9-4 Item number replacement list

Item	Number
BTS number	
Failed BMA	

BMA replacement procedure



WARNING

BMA mounting screws must be tightened to the specified torque to prevent arcing and possible fire hazard.

To replace a BMA perform [Procedure 9-3](#) and then [Procedure 9-4](#).

Procedure 9-3 Removing the failed BMA

AT THE OMCR	
1	Shut down site signaling functions according to Procedure 3-2 Shutdown site signaling functions procedure for a packet BTS on page 3-5 .
AT THE BTS SITE	
2	Power down the UBS Macro BTS frame according to the section: Powering Down the Frame on page 2-3 .

Continued

Procedure 9-3 Removing the failed BMA (Continued)



CAUTION

Make sure the facility circuit breaker controlling external AC or DC power, whichever is applicable, to the UBS Macro BTS frame is set to the OFF position.



NOTE

You will be disconnecting multiple cables from connectors. If necessary, use masking tape and a marker and temporarily tag each cable as to the proper connector before disconnection.

- | | |
|----------|--|
| 3 | Set all PDU front panel circuit breakers to the off (pulled out) position. |
| 4 | Disconnect all DC power cables from the PDU front panel. Dress these cables away from the PDU front panel. |
| 5 | Remove the PDU front panel as follows: <ul style="list-style-type: none"> • See Figure 9-1 PDU Front Panel Removal/Installation Detail on page 9-12. • While depressing the front panel cover latch tab on the left and right front ends of the PDU, slide the PDU front panel forward and off of the PDU. |
| 6 | Remove the BMA as follows: <ul style="list-style-type: none"> • See Figure 9-2 PDU Front Panel (cover removed) on page 9-12. • Locate the BMA to be removed. • Using a TORX T25 driver, remove the BMA mounting screws. • Remove the BMA from the PDU. |

Procedure 9-4 Installing the replacement BMA

AT THE BTS SITE

1



WARNING

BMA mounting screws must be tightened to the specified torque to prevent arcing and possible fire hazard.

Install the replacement BMA as follows:

- See [Figure 9-2 PDU Front Panel \(cover removed\) on page 9-12](#).

Continued

Procedure 9-4 Installing the replacement BMA (Continued)

	<ul style="list-style-type: none"> • Properly position the replacement BMA on the PDU output bus bars. • Align the BMA screw holes with the appropriate screw holes on the PDU output bus bars. • Insert the mounting screws. • Using a TORX T25 driver, tighten all BMA mounting screws to 4.8 N-m (42.25 in-lb).
2	<p>Reattach the PDU front panel cover to the PDU as follows:</p> <ul style="list-style-type: none"> • See Figure 9-1 PDU Front Panel Removal/Installation Detail on page 9-12. • Align the PDU front panel cover with the PDU circuit breaker actuators and power connectors while inserting the PDU front panel cover latch tabs into the retainer on the left and right front ends of the PDU. • Slide the PDU front panel cover onto the front of the PDU. • Firmly press on the ends of the PDU front panel until each end tab snaps into place.
3	Set all PDU front panel circuit breakers to the off (pulled out) position.
4	Reconnect all applicable cables to the PDU front panel connectors. Make sure that each cable is connected to the proper PDU front panel power connector.
5	<p>Power up the UBS Macro BTS frame according to the section: Power-up the Frame on page 2-3.</p> <div style="display: flex; align-items: center; margin-top: 10px;">  <div style="margin-left: 10px;"> <p>NOTE</p> <p>There is no optimization required for the BMA replacement.</p> </div> </div>
AT THE OMCR	
6	Restore site signaling operations according to Procedure 3-3 Restore site signaling operations procedure for a packet BTS on page 3-10 .

Reference diagrams

[Figure 9-1](#) shows details for removing and installing the PDU front cover. [Figure 9-2](#) shows BMA mounting details.

Figure 9-1 PDU Front Panel Removal/Installation Detail

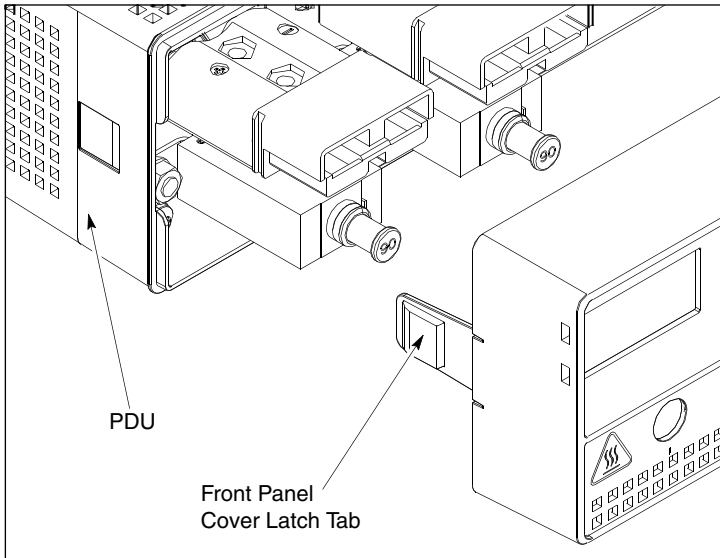

ti-cdma-06382.eps

Figure 9-2 PDU Front Panel (cover removed)

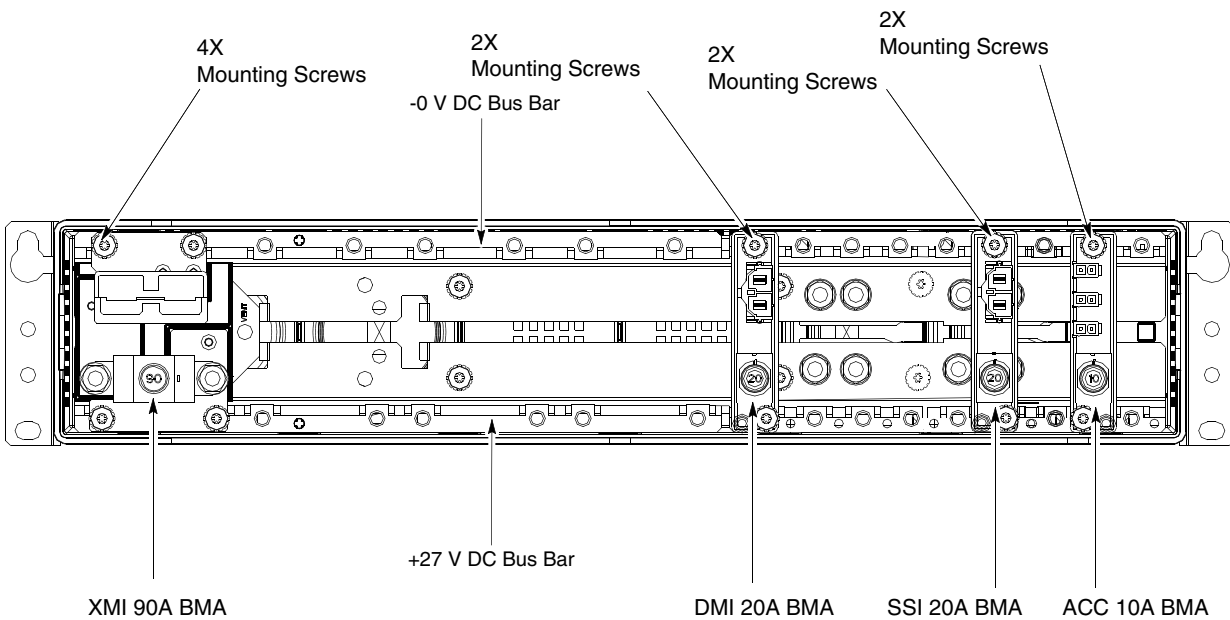

NOTE:
1. This diagram shows mounting details for each kind of BMA.
It does not show the exact BMA equipage.

ti-cdma-06383.eps

PSM Shelf Replacement Procedures

-48 V DC Power Supply Module (PSM) Shelf

-48 V DC PSM Shelf Description

The -48 V DC Power Supply Module (PSM) shelf is optional. It is used to convert -48 V DC input power to +27V DC output operating power for distribution to the UBS Macro BTS frame electronics.

The -48 V DC PSM shelf is located at the bottom of the UBS Macro BTS frame. [Figure 1-1 UBS Macro BTS low-tier/low-capacity frame \(1000 mm rack\) on page 1-27](#), [Figure 1-2 Low capacity UBS Macro BTS starter frame \(1800 mm rack\) on page 1-28](#) and [Figure 1-3 UBS Macro BTS mid-capacity frame \(1800 mm rack\) on page 1-30](#) show the location of the -48 V DC PSM shelf within the UBS Macro BTS frame.

[Figure 1-15 -48 V DC and 220 V AC PSM shelves front panel detail on page 1-46](#) shows the location of I/O port connectors and PSM slots on the front of the -48 V DC PSM shelf.

[Figure 1-16 -48 V DC PSM shelf rear panel detail on page 1-47](#) shows the location of input connector and output cable on the rear of the -48 V DC PSM shelf.

The -48 V DC PSM shelf provides interconnection between the PSM slots DC I/O and the PSM shelf DC I/O as well as interconnection between the PSM slots alarm/status I/O and the PSM shelf alarm & control I/O.

The plug-in PSMs provide DC-DC conversion and +27V DC power output capabilities.

Up to three PSMs can be housed in the PSM shelf. A minimum of two PSMs are equipped for redundancy. An empty PSM 3 slot is covered with a filler panel.

PSM shelf plug-in modules

The -48 V DC PSM is a DC-DC converter. It operates from a nominal -48 V DC (-39 to -72 V) input and provides a 2700 W, +27 V DC (+/- 0.1 V) output. The output is designed to support load current sharing when configured for parallel output operation with other -48 V DC PSMs.

Three PSMs can provide a maximum of 8100 W, +27 V DC (+/- 0.1 V) output from the -48 V DC PSM shelf.

Each PSM has internal fans that circulate cooling air from the front to the rear of the module.

Each PSM slides into a slot in the shelf. Blade type contacts, on the rear of the PSM, mate with the DC I/O bus bar contacts in the PSM slot.

PSM shelf DC I/O interconnection

Each PSM slot in the -48 V DC PSM shelf has two contacts (- feed and + return) for 48 V DC input and two contacts (+ feed and - return) for +27 V DC output.

The -48 V DC PSM shelf has DC I/O bus bars at the rear of the shelf. The 48 V DC input contacts of the three PSM slots are parallel connected to the DC input bus bars. The +27 V DC output contacts of the three PSM slots are parallel connected to DC input bus bars.

The DC input bus bars are interconnected to the -48 V DC input power connector on the rear of the PSM shelf.

The DC output bus bars are interconnected to the +27 V DC output power cable on the rear of the PSM shelf. This cable connects to the +27 V DC input power cable on the rear of the UBS Macro PDU. The PDU distributes the +27V DC operating power to the UBS Macro frame electronics.

PSM shelf alarm and control I/O interconnection

Each PSM slot has a bulkhead connector. The I/O signals of each of these slot connectors are interconnected to the ALARM & CONTROL connector on the front of the -48 V DC PSM shelf.

Each -48 V DC PSM has a rear panel status/alarm drawer connector that mates with the bulkhead connector in the PSM slot of the PSM shelf. The I/O signals of this connector are interconnected to the ALARM & CONTROL connector on the front of the -48 V DC PSM shelf. This connector is cabled to the SSI front panel PSM connector. This allows the PSM alarm & status to be monitored by the SSI. It also allows the front panel LEDs and module enable to be controlled by the SSI.

PSM alarm & status signal inputs are current share, temp alarm, converter fail, fan fail, high temp, low bus voltage, input voltage loss, presence, and EID.

The current share signal goes directly from one PSM to the others via PSM shelf backplane looping without going to the SSI. Based on PSM alarm & status, the SSI outputs signals to control the state of the LEDs.



NOTE

The PSM shelf ALARM & CONTROL cable also contains the PSM enable line which must be grounded at the SSI in order for the PSM to operate.

System impact/considerations



NOTE

Performing this replacement procedure will cause BTS downtime and interrupt all call processing.

Prior to replacing the -48 V DC PSM shelf, the UBS Macro BTS site signaling is shutdown (i.e., disable the BTS site) then the UBS Macro BTS frame is powered down.

Table 10-1 -48 V DC PSM Shelf Replacement Conditions

FRU	Ref Designator	What to Shutdown...
-48 V DC Power Supply Module (PSM) shelf	-48 V DC PSM shelf	Shutdown site signaling functions and then power down the frame.

Required items

Documents

- 1X UBS Macro BTS Optimization/ATP manual.

Tools

- Torque driver
- T25 TORX driver

Torque requirements

- PSM shelf mounting screws; 4.77 N-m (42 in-lb)
- PSM captive M4 retaining thumbscrew, 2.37 N-m (21 in-lb)

Replacement unit

- -48 V DC PSM shelf assembly (Motorola model STHN4089)

Prerequisites



NOTE

Coordinate this repair task with the OMCR operator.

Before you begin

Before you begin, record the pertinent information in [Table 10-2](#).

Table 10-2 Item number replacement list

Item	Number
BTS number	
Failed -48 V DC PSM shelf number	

-48 V DC PSM shelf replacement procedure



CAUTION

This procedure requires working on or around circuitry which is extremely sensitive to ESD. Wear a conductive, high impedance wrist strap during the procedure. Use appropriate safety measures.



To replace the -48 V DC PSM shelf perform [Procedure 10-1](#) and then [Procedure 10-2](#).

Procedure 10-1 Removing the failed -48 V DC PSM shelf

AT THE OMCR	
1	Shut down site signaling functions according to Procedure 3-2 Shutdown site signaling functions procedure for a packet BTS on page 3-5 .
AT THE BTS SITE	
2	Power down the -48 V DC UBS Macro BTS frame according to the section: Powering Down the Frame on page 2-3 .
	 <div style="border: 1px solid black; padding: 2px; display: inline-block; margin: 5px 0;">CAUTION</div> <p>Make sure the facility circuit breaker controlling external 48 V DC power to the -48 V DC PSM shelf is set to the OFF position.</p>
3	Using a T25 TORX bit and driver, loosen the captive retaining thumbscrews on all of the PSM modules until the thumbscrews are disengaged from the shelf.

Continued

Procedure 10-1 Removing the failed -48 V DC PSM shelf (Continued)

4	 <div style="border: 1px solid black; background-color: #f4a460; padding: 2px; display: inline-block; margin-left: 10px;">WARNING</div> <p>PSM weighs approximately 5 kg. Be careful when handling the PSM to prevent damage to the equipment and personal injury.</p> <p>Remove all the PSMs from the slots of the -48 V DC PSM shelf. Grasp the handle on the front panel of the PSM with one hand. Slowly pull the PSM out of the shelf slot while carefully supporting the bottom of the module with the other hand.</p>
5	Remove the filler panels (if used) from the slots of the -48 V DC PSM shelf. Using a T25 TORX bit and driver, loosen the captive retaining thumbscrew on the filler panel until it is disengaged from the shelf.
6	 <div style="border: 1px solid black; background-color: #00ffff; padding: 2px; display: inline-block; margin-left: 10px;">NOTE</div> <p>You will be disconnecting multiple cables from connectors. If necessary, use masking tape and a marker and temporarily tag each cable as to the proper connector before disconnection.</p>
6	Disconnect the +27 V DC output power cable on the rear of the PSM shelf from the +27 V DC input power cable on the rear of the PDU by separating the orange connectors.
7	Disconnect the -48 V DC input power cable from the rear of the -48 V DC PSM shelf by separating the blue connectors.
8	Disconnect all of the cables connected to the -48 V DC PSM shelf front panel connectors.
9	Loosen the two rack mounting screws in the keyhole slots of the -48 V DC PSM shelf rack mounting flanges. Do not remove these two screws. Leave the screw heads extending 8 mm out from the rack surface. These two screws will serve as hanger screws.
10	Completely loosen and remove the remaining rack mounting screws in the -48 V DC PSM shelf rack mounting flanges.
11	Grasp the -48 V DC PSM shelf and lift it up and off of the hanger screws. Pull the -48 V DC PSM shelf out of the rack and set it out of the way.

Procedure 10-2 Installing the replacement -48 V DC PSM shelf

AT THE BTS SITE	
1	Properly position the replacement -48 V DC PSM shelf in the rack location. Align the keyhole slots of the PSM shelf rack mounting flanges with the two hanger screws and hang the shelf on the rack.
2	Insert screws in the 6 open slots of the PSM shelf rack mounting flanges. Tighten all 8 PSM shelf rack mounting screws to 4.77 N-m (42 in-lb).

Continued

Procedure 10-2 Installing the replacement -48 V DC PSM shelf (Continued)

3	Reinstall all of the PSMs. Properly orient each PSM and insert it into the appropriate PSM shelf slot. Slowly slide the module into the shelf until the rear connectors are fully seated. Make sure that the PSM is fully engaged with the shelf backplane slot connectors.
4	Using a T25 TORX bit and torque driver, tighten the captive retaining thumbscrews of each PSM to 2.37 N-m (21 in-lb).
5	Reinstall filler panels over any empty PSM slots of the -48 V DC PSM shelf. Using a T25 TORX bit and driver, tighten the captive retaining thumbscrew on the filler panel to 2.37 N-m (21 in-lb).
6	Reconnect all applicable cables to the -48 V DC PSM shelf front panel connectors.
7	Connect the -48 V DC input power cable to the rear of the -48 V DC PSM shelf by mating the blue connectors.
8	Connect the +27 V DC output power cable on the rear of the PSM shelf to the +27 V DC input power cable on the rear of the PDU by mating the orange connectors.
9	Power up the -48 V DC UBS Macro BTS frame according to the section: Power-up the Frame on page 2-3 .
10	Observe the LEDs on the front of the PSMs. The green LED should be on and the red LED should be off. This indicates normal operation.

**NOTE**

There is no optimization required for the PSM shelf replacement.

AT THE OMCR

11	Restore site signaling operations according to Procedure 3-3 Restore site signaling operations procedure for a packet BTS on page 3-10 .
-----------	--

220 V AC Power Supply Module (PSM) Shelf

220 V AC PSM Shelf Description

The 220 V AC Power Supply Module (PSM) shelf is optional. It is used to convert 220 V AC input power to +27V DC output operating power for distribution to the UBS Macro BTS frame electronics.

The 220 V AC PSM shelf is located at the bottom of the UBS Macro BTS frame. [Figure 1-1 UBS Macro BTS low-tier/low-capacity frame \(1000 mm rack\) on page 1-27](#), [Figure 1-2 Low capacity UBS Macro BTS starter frame \(1800 mm rack\) on page 1-28](#) and [Figure 1-3 UBS Macro BTS mid-capacity frame \(1800 mm rack\) on page 1-30](#) show the location of the 220 V AC PSM shelf within the UBS Macro BTS frame.

[Figure 1-15 -48 V DC and 220 V AC PSM shelves front panel detail on page 1-46](#) shows the location of I/O port connectors and PSM slots on the front of the 220 V AC PSM shelf.

[Figure 1-17 220 V AC PSM shelf rear panel detail on page 1-48](#) shows the location of input connector and output cable/connector on the rear of the 220 V AC PSM shelf.

The 220 V AC PSM shelf provides interconnection between the PSM slots AC input/DC output and the PSM shelf AC input/DC output as well as interconnection between the PSM slots alarm/status I/O and the PSM shelf alarm & control I/O.

The plug-in PSMs provide AC-DC conversion and +27V DC power output capabilities.

Up to three PSMs can be housed in the PSM shelf. A minimum of two PSMs are equipped for redundancy. An empty PSM 3 slot is covered with a filler panel.

PSM shelf plug-in modules

The 220 V AC PSM is an AC-DC power supply. It contains AC line input filtering and AC-DC rectification. The rectifier output is applied to a DC-DC converter.

The 220 V AC PSM operates from a nominal 220 V AC (154 to 300 V) input and provides a 2700 W, +27 V DC (+/- 0.1 V) output. The output is designed to support load current sharing when configured for parallel output operation with other 220 V AC PSMs.

Three PSMs can provide a maximum of 8100 W, +27 V DC (+/- 0.1 V) output from the 220 V AC PSM shelf.

Each PSM has internal fans that circulate cooling air from the front to the rear of the module.

Each PSM slides into a slot in the PSM shelf. The AC input & status/alarm drawer connector, on the rear of the PSM, mates with a bulkhead connector in the PSM slot. Also blade type contacts, on the rear of the PSM, mate with the DC output bus bar contacts in the PSM slot.

PSM shelf AC input interconnection

Each PSM slot in the 220 V AC PSM shelf has a bulkhead connector. The 220 V AC line input pins from the bulkhead connector of the three PSM slots are parallel connected to the AC input buses.

Each 220 V AC PSM has a rear panel AC input & status/alarm drawer connector that mates with a bulkhead connector in the PSM slot of the 220 V AC PSM shelf.

The AC line input buses in the 220 V AC PSM shelf are connected to the AC input terminal block on the rear of the 220 V AC PSM shelf. This terminal block is wired to the AC input lines.

The 220 V AC PSM shelf and 220 V AC PSMs can operate with any one of the following AC power inputs:

- Single-Phase
- 3-Phase STAR
- 3-Phase DELTA

PSM shelf DC output interconnection

Each PSM slot in the 220 V AC PSM shelf has two contacts (+ feed and – return) for +27 V DC output.

The 220 V AC PSM shelf has DC output bus bars at the rear of the shelf. The +27 V DC output contacts of the three PSM slots are parallel connected to DC input bus bars.

The DC input bus bars are interconnected to the 220 V AC input power connector on the rear of the PSM shelf.

The DC output bus bars are interconnected to the +27 V DC output power cable on the rear of the PSM shelf. This cable connects to the +27 V DC input power cable on the rear of the UBS Macro PDU. The PDU distributes the +27V DC operating power to the UBS Macro frame electronics.

In addition, the DC output bus bars are interconnected to the +27 V DC output power connector on the rear of the 220 V AC PSM shelf. Usage of this connector is optional. It can be cabled to back-up batteries for battery charging purposes.

PSM shelf alarm and control I/O interconnection

Each PSM slot has a bulkhead connector. The status/alarm I/O signals of each of these slot connectors are interconnected to the ALARM & CONTROL connector on the front of the 220 V AC PSM shelf.

Each 220 V AC PSM has a rear panel status/alarm drawer connector that mates with the bulkhead connector in the PSM slot of the PSM shelf. The I/O signals of this connector are interconnected to the ALARM & CONTROL connector on the front of the 220 V AC PSM shelf. This connector is cabled to the SSI front panel PSM connector. This allows the PSM alarm & status to be monitored by the SSI. It also allows the front panel LEDs and module enable to be controlled by the SSI.

PSM alarm & status signal inputs are current share, temp alarm, converter fail, fan fail, high temp, low bus voltage, input voltage loss, presence, and EID.

The current share signal goes directly from one PSM to the others via PSM shelf backplane looping without going to the SSI. Based on PSM alarm & status, the SSI outputs signals to control the state of the LEDs.



NOTE

The PSM shelf ALARM & CONTROL cable also contains the PSM enable line which must be grounded at the SSI in order for the PSM to operate.

System impact/considerations



NOTE

Performing this replacement procedure will cause BTS downtime and interrupt all call processing.

Prior to replacing the 220 V AC PSM shelf, the UBS Macro BTS site signaling is shutdown (i.e., disable the BTS site) then the UBS Macro BTS frame is powered down.

Table 10-3 220 V AC PSM Shelf Replacement Conditions

FRU	Ref Designator	What to Shutdown...
220 V AC Power Supply Module (PSM) shelf	220 V AC PSM shelf	Shutdown site signaling functions and then power down the frame.

Required items

Documents

- *1X UBS Macro BTS Optimization/ATP* manual.

Tools

- Torque driver
- T25 TORX driver
- T20 TORX bit with 12-inch extension
- Flat blade screwdriver

Torque requirements

- PSM shelf mounting screws; 4.77 N-m (42 in-lb)
- PSM captive M4 retaining thumbscrew, 2.37 N-m (21 in-lb)
- Terminal block cover box screws, 1.6 - 1.8 N-m (14 - 16 in-lb)

Replacement unit

- 220 V AC PSM shelf assembly (Motorola model STHN4092)

Prerequisites



NOTE

Coordinate this repair task with the OMCR operator.

Before you begin

Before you begin, record the pertinent information in [Table 10-4](#).

Table 10-4 Item number replacement list

Item	Number
BTS number	
Failed 220 V AC PSM shelf number	

220 V AC PSM shelf replacement procedure



CAUTION

This procedure requires working on or around circuitry which is extremely sensitive to ESD. Wear a conductive, high impedance wrist strap during the procedure. Use appropriate safety measures.

To replace the 220 V AC PSM shelf perform [Procedure 10-3](#) and then [Procedure 10-4](#).

Procedure 10-3 Removing the failed 220 V AC PSM shelf

AT THE OMCR	
1	Shut down site signaling functions according to Procedure 3-2 Shutdown site signaling functions procedure for a packet BTS on page 3-5 .
AT THE BTS SITE	
2	Power down the 220 V AC UBS Macro BTS frame according to the section: Powering Down the Frame on page 2-3 .
	<div style="border: 1px solid black; padding: 2px; display: inline-block; margin-left: 10px;">CAUTION</div> <p>Make sure the facility circuit breaker controlling external 220 V AC power to the 220 V AC PSM shelf is set to the OFF position.</p>
3	Using a T25 TORX bit and driver, loosen the captive retaining thumbscrews on all of the PSM modules until the thumbscrews are disengaged from the shelf.

Continued

Procedure 10-3 Removing the failed 220 V AC PSM shelf (Continued)

4

**WARNING**

PSM weighs approximately 5 kg. Be careful when handling the PSM to prevent damage to the equipment and personal injury.

Remove all the PSMs from the slots of the 220 V AC PSM shelf.
Grasp the handle on the front panel of the PSM with one hand. Slowly pull the PSM out of the shelf slot while carefully supporting the bottom of the module with the other hand.

5

Remove the filler panels (if used) from the slots of the 220 V AC PSM shelf. Using a T25 TORX bit and driver, loosen the captive retaining thumbscrew on the filler panel until it is disengaged from the shelf.

**NOTE**

You will be disconnecting multiple cables/wires from connectors. If necessary, use masking tape and a marker and temporarily tag each cable as to the proper connector before disconnection.

6

Disconnect the +27 V DC output power cable on the rear of the PSM shelf from the +27 V DC input power cable on the rear of the PDU by separating the orange connectors.

7

Disconnect the back-up battery cable (if used) from the +27 V DC output power connector on the rear of the 220 V AC PSM shelf by separating the orange connectors.

8

Using a TORX T20 bit and driver, remove the 4 screws securing the terminal block cover box to the 220 V AC PSM shelf. Remove the terminal block cover box from the PSM shelf.

**NOTE**

The terminal block cover box may have conduit attached to it. It may be necessary to free the conduit so that the box can be moved out of the way.

9

Using a flat blade screwdriver, turn the ground terminal screw counter clockwise (CCW) to open the terminal.
Disconnect the ground wire from the terminal.

10

Using a flat blade screwdriver, turn each AC supply line wire terminal screw counter clockwise (CCW) to open the terminals.
Disconnect the AC supply line wires from the terminals.

11

Disconnect all of the cables connected to the 220 V AC PSM shelf front panel connectors.

12

Using TORX T25 driver, loosen the two rack mounting screws in the keyhole slots of the 220 V AC PSM shelf rack mounting flanges. Do not remove these two screws. Leave the screw heads extending 8 mm out from the rack surface. These two screws will serve as hanger screws.

Continued

Procedure 10-3 Removing the failed 220 V AC PSM shelf (Continued)

13	Using TORX T25 driver, completely loosen and remove the remaining rack mounting screws in the 220 V AC PSM shelf rack mounting flanges.
14	Grasp the 220 V AC PSM shelf and lift it up and off of the hanger screws. Pull the 220 V AC PSM shelf out of the rack and set it out of the way.

Procedure 10-4 Installing the replacement 220 V AC PSM shelf**AT THE BTS SITE**

1	Using a TORX T20 bit and driver, remove the 4 screws securing the terminal block cover box to the rear of the replacement 220 V AC PSM shelf. Remove the terminal block cover box from the PSM shelf.
2	Make sure that the AC line terminal block on the replacement 220 V AC PSM shelf is properly configured with insertion bridging. It should match that of the failed 220 V AC PSM shelf. If necessary, use a flat blade screwdriver to open terminals (turn screws CCW) for insertion bridge placement. Place an insertion bridge into the proper terminals. While holding the bridge with one hand, turn the corresponding terminal screws CW until the bridge is securely clamped.
3	Properly position the replacement 220 V AC PSM shelf in the rack location. Align the keyhole slots of the PSM shelf rack mounting flanges with the two hanger screws and hang the shelf on the rack.
4	Insert screws in the 6 open slots of the PSM shelf rack mounting flanges. Using TORX T25 driver, tighten all 8 PSM shelf screws to 4.77 N-m (42 in-lb).
5	Reinstall all of the PSMs. Properly orient each PSM and insert it into the appropriate PSM shelf slot. Slowly slide the module into the shelf until the rear connectors are fully seated. Make sure that the PSM is fully engaged with the shelf backplane slot connectors.
6	Using a T25 TORX bit and torque driver, tighten the captive retaining thumbscrews of each PSM to 2.37 N-m (21 in-lb).
7	Reinstall filler panels over any empty PSM slots of the 220 V AC PSM shelf. Using a T25 TORX bit and driver, tighten the captive retaining thumbscrew on the filler panel to 2.37 N-m (21 in-lb).
8	Reconnect all applicable cables to the 220 V AC PSM shelf front panel connectors.
9	Connect the 220 V AC input lines to the proper terminals on the rear of the 220 V AC PSM shelf by performing the following: <ul style="list-style-type: none"> ● Use a flat blade screwdriver to open the terminals (turn screws CCW) ● Insert the appropriate wire into the terminal. ● While holding the wire with one hand, turn the corresponding terminal screw CW until the wire is securely clamped. Tighten the terminal screw to 4.0 - 4.5 N-m (35 - 40 in-lb).

Continued

Procedure 10-4 Installing the replacement 220 V AC PSM shelf (Continued)

10	Using a flat blade screwdriver, turn the ground terminal screw counter clockwise (CCW) until the terminal is fully open. Insert the earth ground wire into the ground terminal. Turn the ground terminal screw clockwise (CW) to close the terminal and secure the wire. Tighten the terminal screw to 4.0 - 4.5 N-m (35 - 40 in-lb).
11	Place the cover box, with conduit attached, in position over the AC input terminal block.
12	Insert the 4 screws to secure the cover box to the PSM shelf. Ensure that the wires are not pinched.
13	Using a TORX T20 bit and driver, tighten the 4 screws to 1.6 - 1.8 N-m (14 - 16 in-lb).
14	Connect the back-up battery cable (if used) the +27 V DC output power connector on the rear of the 220 V AC PSM shelf by mating the orange connectors.
15	Connect the +27 V DC output power cable on the rear of the PSM shelf to the +27 V DC input power cable on the rear of the PDU by mating the orange connectors.
16	Power up the 220 V AC UBS Macro BTS frame according to the section: Power-up the Frame on page 2-3 .
17	Observe the LEDs on the front of the PSMs. The green LED should be on and the red LED should be off. This indicates normal operation.

**NOTE**

There is no optimization required for the PSM shelf replacement.

AT THE OMCR

18	Restore site signaling operations according to Procedure 3-3 Restore site signaling operations procedure for a packet BTS on page 3-10 .
-----------	--

Power Supply Modules (PSMs)

PSM Descriptions

Up to three PSMs can be housed in the PSM shelf. A minimum of two PSMs are equipped for redundancy. An empty PSM 3 slot is covered with a filler panel. Refer to [Figure 1-15 –48 V DC and 220 V AC PSM shelves front panel detail on page 1-46](#).

There are two types of PSMs that can be used with the UBS Macro BTS PSM shelf. These are as follows:

- –48 V DC PSM
- 220 V AC PSM

The –48 V DC PSMs are only used in a –48 V DC PSM shelf.

The 220 V AC PSMs are only used in a 220 V AC PSM shelf.



CAUTION

Never plug a –48 V DC PSM into a 220 V AC PSM shelf.
Never plug a 220 V AC PSM into a –48 V DC PSM shelf.

-48 V DC PSM Description

The -48 V DC PSM is a DC-DC converter. It operates from a nominal -48 V DC (-39 to -72 V) input and provides a 2700 W, +27 V DC (+/- 0.1 V) output. The output is designed to support load current sharing when configured for parallel output operation with other -48 V DC PSMs. The PSM has internal fans that circulate cooling air from the front to the rear of the module.

Each -48 V DC PSM slides into a slot in the -48 V DC PSM shelf. Blade type contacts, on the rear of the -48 V DC PSM, mate with the DC input/output bus bars at the rear of the -48 V DC PSM shelf.

Each -48 V DC PSM has a rear panel status/alarm drawer connector that mates with a bulkhead connector in the PSM slot of the PSM shelf. The I/O signals of this connector are interconnected to the ALARM & CONTROL connector on the front of the -48 V DC PSM shelf. This connector is cabled to the SSI front panel PSM connector. This allows the PSM alarm & status to be monitored by the SSI. It also allows the front panel LEDs and module enable to be controlled by the SSI.

PSM alarm & status signal inputs are current share, temp alarm, converter fail, fan fail, high temp, low bus voltage, input voltage loss, presence, and EID.

The current share signal goes directly from one PSM to the others via PSM shelf backplane looping without going to the SSI. Based on PSM alarm & status, the SSI outputs signals to control the state of the LEDs.



NOTE

The PSM shelf ALARM & CONTROL cable also contains the PSM enable line which must be grounded at the SSI in order for the PSM to operate.

220 V AC PSM Description

The 220 V AC PSM is an AC–DC power supply. It contains AC line input filtering and AC–DC rectification. The rectifier output is applied to a DC–DC converter.

The 220 V AC PSM operates from a nominal 220 V AC (154 to 300 V) input and provides a 2700 W, +27 V DC (+/- 0.1 V) output. The output is designed to support load current sharing when configured for parallel output operation with other 220 V AC PSMs. The PSM has internal fans that circulate cooling air from the front to the rear of the module.

Each 220 V AC PSM slides into a slot in the 220 V AC PSM shelf. Blade type contacts, on the rear of the 220 V AC PSM, mate with the DC output bus bars at the rear of the 220 V AC PSM shelf.

Each 220 V AC PSM has a rear panel AC input & status/alarm drawer connector that mates with a bulkhead connector in the PSM slot of the 220 V AC PSM shelf. The AC line input buses in the 220 V AC PSM shelf connect to the AC input lines of the AC input & status/alarm drawer connector. The status/alarm I/O signals of this connector are interconnected to the ALARM & CONTROL connector on the front of the PSM shelf. This connector is cabled to the SSI front panel PSM connector. This allows the PSM alarm & status to be monitored by the SSI. It also allows the front panel LEDs and module enable to be controlled by the SSI.

PSM alarm & status signal inputs are current share, temp alarm, converter fail, fan fail, high temp, low bus voltage, input voltage loss, presence, and EID.

The current share signal goes directly from one PSM to the others via PSM shelf backplane looping without going to the SSI. Based on PSM alarm & status, the SSI outputs signals to control the state of the LEDs.



NOTE

The PSM shelf ALARM & CONTROL cable also contains the PSM enable line which must be grounded at the SSI in order for the PSM to operate.

System impact/considerations

This replacement procedure does not require system downtime. However, alarms may be generated.

Two PSMs provide N + 1 redundancy and load sharing for its respective PSM shelf. In the event of a PSM failure, one PSM is capable of providing operating power for its respective PSM shelf. However, a failed PSM should be replaced as soon as possible to maintain redundancy.

The PSM is hot-swappable.

Table 10-5 FRU replacement conditions

FRU	Ref Designator	What to Shutdown...
-48 V DC Power Supply Module	-48 V DC PSM	Nothing; FRU is hot swappable and redundant.
220 V AC Power Supply Module	220 V AC PSM	Nothing; FRU is hot swappable and redundant.

PSM Front and Rear Panel Details

-48 V DC PSM Front & Rear Panels

Figure 10-1 shows the -48 V DC PSM front and rear panel details.



NOTE

The figure below shows the PSM front and rear panels rotated 90 degrees Counter Clockwise (CCW) from when it is installed in the PSM shelf.

Figure 10-1 -48 V DC PSM Front & Rear Details

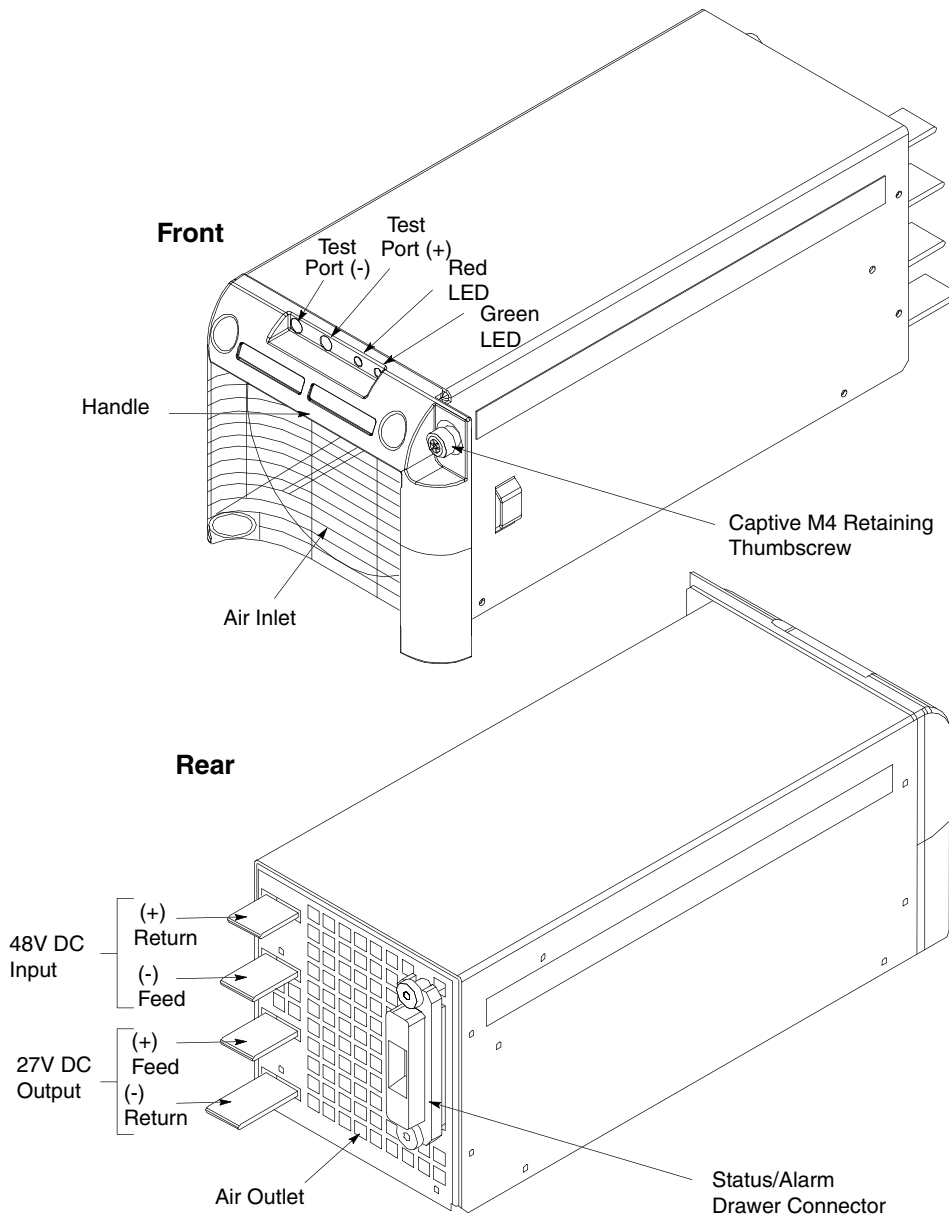

ti-cdma-05920.eps

220 V AC PSM Front & Rear Panels

Figure 3-6 shows the 220 V AC PSM front and rear panel details.



NOTE

The figure below shows the PSM front and rear panels rotated 90 degrees Counter Clockwise (CCW) from when it is installed in the PSM shelf.

Figure 10-2 220 V AC PSM Front & Rear Details

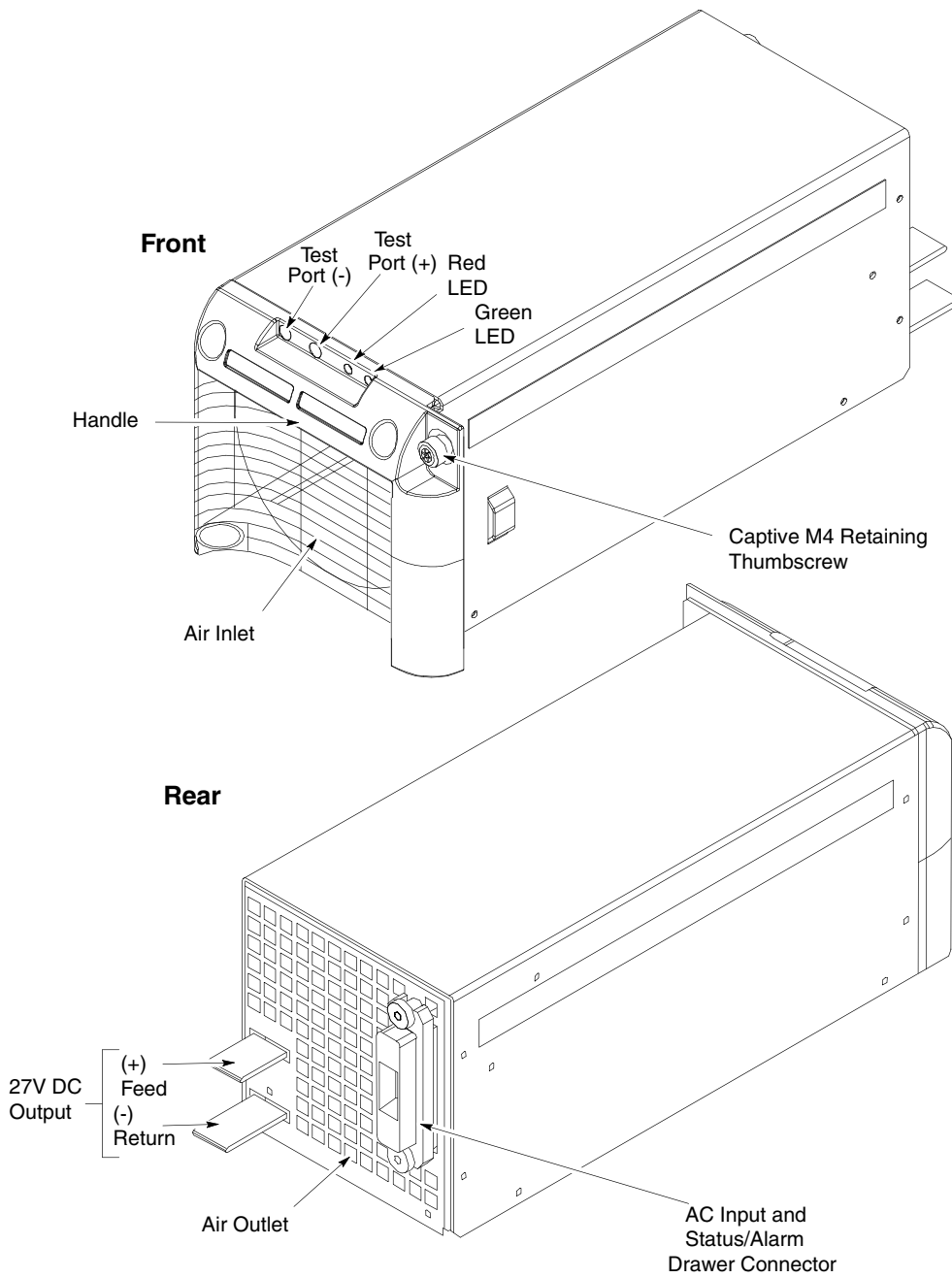

ti-cdma-05921.eps

Front Panel LEDs

Two LEDs are on the front panel of each PSM with the following functionality:

- A GREEN LED is displayed when the PSM is enabled and the output voltage is present. This LED remains on during a minor alarm condition.
- A RED LED is displayed when a hard failure occurs (for example; a Fan failure or Converter failure).

Front Panel Test Ports

A high impedance DC voltmeter can be connected between the two test ports on the front panel to monitor the DC output voltage.

Rear Panel Connectors

Blade type contacts, on the rear of the PSM, mate with the DC input/output bus bars at the rear of the PSM shelf.

The status/alarm drawer connector on the rear of the PSM mates with a bulkhead connector at the rear of the PSM shelf. This connector is cabled to the PSM alarm connector on the front of the PSM shelf.

Required items

Documents

- None

Tools

- Torque driver
- T25 TORX driver

Torque requirements

- PSM captive M4 retaining thumbscrew, 2.37 N-m (21 in-lb)

Replacement unit

- -48 V DC Power Supply Module (-48 V DC PSM) — Motorola model STPN4037
- 220 V AC Power Supply Module (220 V AC PSM) — Motorola model STPN4036

Prerequisites

Before you begin

Before you begin, record the pertinent information in [Table 10-6](#).

Table 10-6 Item number replacement list

Item	Number
BTS number	
Failed -48 V DC PSM number	
Failed 220 V AC PSM number	

PSM replacement procedure



WARNING

The PSM weighs approximately 5 kg. Be careful when handling the PSM to prevent damage to the equipment and personal injury.



CAUTION

Wearing anti-static wrist straps during this procedure is not recommended. Occasionally during this procedure, touch the frame ground to dissipate static electricity.



Perform the steps described in [Procedure 10-5](#) to replace either a -48 V DC PSM or a 220 V AC PSM.

Procedure 10-5 Replacing a PSM

1	Notify the OMC-R operator that you are replacing the -48 V DC/220 V AC PSM.
2	It will be helpful if the OMC-R operator executes "ENABLE EVENTS" command at the CLI session of the OMC-R to monitor alarms. This command is optional and may not be useful if executed during a high CPU utilization time.
3	Using a T25 TORX bit and driver, loosen the captive retaining thumbscrew until it is disengaged from the shelf.

Continued

Procedure 10-5 Replacing a PSM (Continued)

4	 <div style="display: inline-block; border: 1px solid black; background-color: #f4a460; padding: 2px 5px; margin-left: 10px;">WARNING</div> <p>PSM weighs approximately 5 kg. Be careful when handling the PSM to prevent damage to the equipment and personal injury.</p> <p>Grasp the handle on the front panel of the PSM with one hand. Slowly pull the PSM out of the shelf slot while carefully supporting the bottom of the module with the other hand.</p>
5	<p>Properly orient the replacement PSM and insert it into the slot. Slowly slide the module into the shelf until the rear connectors are fully seated. Make sure that the PSM is fully engaged with the shelf backplane slot connectors.</p>
6	<p>Using a T25 TORX bit and torque driver, tighten the captive retaining thumbscrew to 2.37 N-m (21 in-lb).</p>
7	<p>Observe the LEDs on the PSM. The green LED should be on and the red LED should be off. This indicates normal operation.</p>
	 <div style="display: inline-block; background-color: #00ffff; padding: 2px 5px; margin-left: 10px;">NOTE</div> <p>There is no optimization required for the PSM replacement.</p>
8	<p>Notify the OMC-R operator that the procedure is complete and that alarms should be cleared.</p>
9	<p>OMC-R operator execute "DISABLE EVENTS" command to discontinue monitoring of alarms.</p>

RX Splitter Replacement Procedure

RX Splitter

RX Splitter Description

The RX splitter is only used in UBS Macro BTS frames equipped with more than one XMI.

The RX splitter used in the UBS Macro BTS frame is wide band and handles either 1.9 GHz or 800 MHz RX signals.

The RX splitter is a passive device requiring no DC input operating power.

For the RX splitter location in the UBS Macro frame, refer to [Figure 1-3 UBS Macro BTS mid-capacity frame \(1800 mm rack\) on page 1-30](#).

[Figure 1-14 RX splitter front panel detail on page 1-44](#) shows the location of the RX splitter RF I/O port connectors.

The XMI RX expansion ports (EXP OUT and EXP IN) are connected to the RX splitter.



NOTE

Currently, UBS Macro BTS frames do not support XMI 3 and XMI 4. These will be supported in the future.

In frames equipped with an RX splitter, XMI 1 provides RX main RF antenna signal outputs for each sector to the RX splitter and XMI 2 provides RX diversity RF antenna signal outputs for each sector to the RX splitter. The RX splitter splits the RX main RF antenna signals into outputs to XMI 2, XMI 3 and XMI 4. The RX splitter splits the RX diversity RF antenna signals into outputs to XMI 1, XMI 3 and XMI 4.

The RX splitter XMI 3 and XMI 4 EXP OUT and EXP IN connectors are not currently used.

System impact/considerations



NOTE

Performing this replacement procedure will not cause BTS downtime or suspend any call processing.

Receive diversity on all sectors will be interrupted during the procedure.

TX RF output power on each sector is not affected.

Because the RX splitter is completely passive, the likelihood of its failure is minimal.

The RX splitter is not redundant.

The following strategy is used during replacement of the RX splitter. When the RX splitter is disconnected/removed:

- XMI 1 remains connected to the RX main RF antenna signal outputs for each sector, but has no connection to the RX diversity RF antenna signal outputs for each sector.
- XMI 2 remains connected to the RX diversity RF antenna signal outputs for each sector, but has no connection to the RX main RF antenna signal outputs for each sector.

Alarms will be reported during the replacement procedure.

After the RX splitter is replaced, all affected RX paths must be tested, and if necessary reoptimized to ensure accurate RF power levels. Refer to the *1X UBS Macro BTS Optimization/ATP* manual for test and optimization procedures.

A thorough troubleshooting of the RX antenna paths and all associated XMIs and cables is required to pinpoint a failure to the RX splitter.

Table 11-1 FRU Replacement Conditions

FRU	Ref Designator	What to Shut Down...
RX Splitter	Not Applicable	Nothing

Required Items

Documents

- *1X UBS Macro BTS Optimization/ATP* manual.

Tools

- T25 TORX bit
- Torque driver

Torque Requirements

- M5 mounting screws - 4.77 N-m (42 in-lb)

Replacement Unit

- Wide band (800 MHz through 2.1 GHz RF bands) RX splitter (Motorola model STRG4029)

Prerequisite



NOTE

Coordinate this repair task with the OMCR operator.

Before you begin

Before you begin, enter the information into the following replacement list table.

Table 11-2 Item Number Replacement List

Item	Number
BTS number	
Failed RX splitter number	

RX Splitter Replacement Procedure



CAUTION

This procedure requires working on or around circuitry which is extremely sensitive to ESD. Wear a conductive, high impedance wrist strap during the procedure.

Use appropriate safety measures.

Perform the steps in [Procedure 11-1](#) to replace an RX splitter.

Procedure 11-1 Replacing an RX Splitter

AT THE BTS SITE	
1	Wear a conductive, high impedance wrist strap.
2	Disconnect all cables from the front panel of the RX splitter and move them out of the way.
3	Using a T25 TORX driver, remove the two RX splitter mounting screws; one screw at each of the end mounting tabs on the front of the module.
4	Carefully remove the RX splitter from the bottom of the XMI shelf.
5	Mount the replacement RX splitter to the bottom of the XMI shelf. Use the two RX splitter mounting screws; one screw at each of the end mounting tabs on the front of the module.
6	Using a T25 TORX driver, tighten the two RX splitter mounting screws to 4.77 N-m (42 in-lb).
7	Reconnect all cables to the front panel of the RX splitter.
8	This completes the physical installation of the FRU. If optimization is to be performed at this time, see Optimization Required following this table.

Optimization Required

Perform the following BTS Optimization/ATP procedures:

- RSSI Test (FER Test is optional)

Refer to the *1X UBS Macro BTS Optimization/ATP* manual for the optimization procedures.

RGPS Head Replacement Procedure

RGPS (Remote GPS) Head

RGPS Head Description

The optional RGPS head is remotely located from the UBS Macro BTS frame. The RGPS head is typically mounted outside on a mast/pole. (See [Figure 1-18 RGPS Head Mounting Details on page 1-50.](#))

The RGPS head contains a GPS Receiver (GPSR) and built-in GPS RF antenna.

The RGPS head 12-pin Deutsch type MMP connector is cabled to the SSI **RGPS** connector. This connection allows the SSI to supply DC power to the RGPS head. In addition, control/data signals are exchanged between the UBS Macro BTS frame and RGPS head via this connection.

The RGPS head successfully tracks and acquires GPS satellites. The RGPS head detects GPS RF signals and extracts a 1 Pulse Per Second (1PPS) timing signal. This 1PPS signal is applied to the DMI controller via the **SSI** connector. The DMI controller contains an internal Medium Stability Oscillator (MSO) that is synchronized to the 1PPS timing signal and locked to the GPS time base. If satellite tracking is lost or if the RGPS head fails, the MSO can maintain system timing for up to 8 hours.

If the UBS Macro BTS frame is equipped with an optional Quartz High Stability Oscillator (QHSO) that is mounted to the rear of the SSI, the DMI controller selects the QHSO as the backup synchronization source instead of the MSO. The QHSO can maintain system timing for up to 24 hours.

Motorola RGPS Heads

Currently there are two Motorola RGPS heads that may be used with UBS Macro BTS equipment (see [Figure 1-19 RGPS Head Equipment on page 1-51.](#)) These are as follows:

- A later version Motorola RGPS head is typically installed at a new UBS Macro BTS site.
- An earlier version Motorola RGPS head already installed at an existing Motorola equipped BTS site that is being upgraded with UBS Macro BTS equipment.

The installed RGPS cabling supports operation of either version RGPS head. However, the later version RGPS head requires that the cabling to the head be routed outside the RGPS mounting mast/pole while the earlier version RGPS head requires that the cabling to the head be routed through the RGPS mounting mast/pole.

System Impact/Considerations



NOTE

Performing this replacement procedure should not require BTS downtime or impact call processing because of MSO or QHSO backup. However RGPS head downtime will occur. And alarms will be reported.



NOTE

A failed RGPS head should be replaced immediately after failure detection and within the applicable MSO/QHSO backup time period (i.e., up to 8 hours MSO and up to 24 hours QHSO).



NOTE

After the replacement RGPS head is re-connected and powered up, it may take up to 30 minutes for the replacement RGPS head to successfully track and acquire satellites.

Table 12-1 FRU Replacement Conditions

FRU	Ref Designator	What to Shut Down...
RGPS head	RGPS	Nothing; FRU is hot swappable and BTS system timing is backed up by either MSO (for up to 8 hours) or QHSO (for up to 24 hours).

Required Items

Documents

- *1X UBS Macro BTS Optimization/ATP* manual.

Tools

- Adjustable wrench

Replacement Unit

- RGPS Head (Motorola model SLN6594), later version
- RGPS Head (Motorola part number 0186012H04), earlier version

If you need to replace the mounting hardware and/or the cable assembly with the RGPS head, contact your Motorola sales representative for the appropriate kits.

Prerequisite



NOTE

Coordinate this repair task with the OMCR operator.

Before You Begin

Before you begin, record the pertinent information in the following table (see [Table 12-2](#)):

Table 12-2 Item Number Replacement List

Item	Number
BTS number	
Failed RGPS Head number	
Replacement RGPS Head number	

RGPS head Replacement Procedure





Perform the steps in [Procedure 12-1](#) to replace the RGPS Head.

Procedure 12-1 RGPS Head Replacement Procedure

AT THE BTS SITE	
1	Notify the OMCR operator that you are starting the replacement procedure and that associated alarm reports can be expected.
2	<ul style="list-style-type: none"> • For removal of the earlier RGPS head (Motorola part number 0186012H04), go to step 3. • For removal of the later RGPS head (Motorola model SLN6594), go to step 12.

Continued

Procedure 12-1 RGPS Head Replacement Procedure (Continued)

3	Create slack in the RGPS cable so that 2 feet of cable can be extended out of the RGPS head end of the mounting pipe/conduit.
4	Loosen the pipe/conduit mounting hardware until the pipe/conduit is free to be unscrewed from the RGPS head.
5	 <div data-bbox="454 489 686 542" style="background-color: #00FFFF; padding: 5px; display: inline-block;">NOTE</div> <p data-bbox="454 595 1396 649">To prevent twisting of cables, do not turn the RGPS head while holding the pipe/conduit.</p> <p data-bbox="327 680 1476 829">Grasp the RGPS head with one hand and the pipe/conduit with the other hand. While holding the head still, unscrew the pipe/conduit from the head and separate the head from the pipe/conduit. Grasp the cable just below the head and pull about 16 inches of cable out of the pipe/conduit until the mating cable connectors are exposed.</p>
6	 <div data-bbox="454 925 686 978" style="background-color: #00FFFF; padding: 5px; display: inline-block;">NOTE</div> <p data-bbox="454 1032 1444 1106">The UBS Macro BTS frame automatically switches over to the backup reference source, QHSO/MSO, after disconnecting a working RGPS head. Alarm/event messages are also triggered.</p>
7	 <div data-bbox="454 1234 686 1287" style="background-color: #00FFFF; padding: 5px; display: inline-block;">NOTE</div> <p data-bbox="454 1340 1460 1393">After connecting the replacement head, the UBS Macro BTS frame automatically switches over to the primary reference source, Remote GPS.</p>
8	Feed the cable slack into the RGPS head end of the mounting pipe/conduit.
9	 <div data-bbox="454 1510 686 1564" style="background-color: #00FFFF; padding: 5px; display: inline-block;">NOTE</div> <p data-bbox="454 1617 1396 1670">To prevent twisting of cables, do not turn the RGPS head while holding the pipe/conduit.</p> <p data-bbox="327 1702 1468 1787">Grasp the RGPS head with one hand and the pipe/conduit with the other hand. Being careful not cross-thread the fitting on the RGPS head, screw the pipe/conduit into the head. Hand tighten only!</p>
10	Tighten the pipe/conduit mounting hardware until the pipe/conduit is securely mounted.

Continued

Procedure 12-1 RGPS Head Replacement Procedure (Continued)

11	Go to step step 16
12	<p>Disconnect the RGPS cable from the RGPS head connector. It may be helpful to create some slack in the RGPS cable.</p> <p> NOTE</p> <p>The UBS Macro BTS frame automatically switches over to the backup reference source, QHSO/MSO, after disconnecting a working RGPS head. Alarm/event messages are also triggered.</p>
13	<p>Remove the RGPS head by grasping the head and unscrewing it from the mounting pipe/conduit.</p> <p> NOTE</p> <p>Turn the RGPS head Counter-Clockwise (CCW), as viewed from the top of the head, to loosen/unscrew.</p>
14	<p>Screw the replacement RGPS head onto the mounting pipe/conduit. Securely tighten the head.</p>
15	<p>Connect the RGPS cable connector to the replacement RGPS head connector. Secure the connection by tightening the spinning connector flange.</p> <p> NOTE</p> <p>After connecting the replacement head, the UBS Macro BTS frame automatically switches over to the primary reference source, Remote GPS.</p>
16	<p> NOTE</p> <p>After the replacement RGPS head is re-connected and powered up, it may take up to 30 minutes for the replacement RGPS head to successfully track and acquire satellites.</p> <p>Notify the OMCR operator that you have completed the replacement procedure.</p>

AT THE OMCR

17	Verify that old alarms are cleared and no new alarms are reported.
18	<p> NOTE</p> <p>If optimization is to be performed at this time, see Optimization Required following this table.</p>

Optimization Required

Consult the *1X UBS Macro BTS Optimization/ATP* manual for the following optimization/test instructions:

- Timing Initialization/Verification



MOTOROLA

Standard Printing Instructions

Part Number	68P09283A64-3
Manual Title	1X UBS Macro BTS FRU
Date	SEP 2007

	CSD/CND (US)
Binder	<ul style="list-style-type: none">- 3 Slant D-ring binder - letter size 11.75in x 11.5in) white PVC.- Capacity depends on size of document. (no larger than 3 in)- Clear pockets on front and spine
Printing	<ul style="list-style-type: none">- Cover / spine text overprinted onto Motorola cover stock.- Body printed double sided onto white letter size (8.5in x 11in) 70lb.
Finishing	<ul style="list-style-type: none">- Shrink wrap contents.

Barcode

