



MOTOROLA

Cellular Networks

APPLICANT: MOTOROLA

FCC ID: IHET5JX1

Installation Manual Exhibit

UBS CDMA XMI Transceiver at 800MHz

R20 1X UBS Macro BTS Hardware Installation

Accuracy

While reasonable efforts have been made to assure the accuracy of this document, Motorola, Inc. assumes no liability resulting from any inaccuracies or omissions in this document, or from use of the information obtained herein. Motorola, Inc. reserves the right to make changes to any products described herein to improve reliability, function, or design, and reserves the right to revise this document and to make changes from time to time in content hereof with no obligation to notify any person of revisions or changes. Motorola, Inc. does not assume any liability arising out of the application or use of any product, software, or circuit described herein; neither does it convey license under its patent rights or the rights of others. It is possible that this publication may contain references to, or information about Motorola products (machines and programs), programming, or services that are not announced in your country. Such references or information must not be construed to mean that Motorola intends to announce such Motorola products, programming, or services in your country.

Copyrights

This document, Motorola products, and 3rd Party Software products described in this document may include or describe copyrighted Motorola and other 3rd Party supplied computer programs stored in semiconductor memories or other media. Laws in the United States and other countries preserve for Motorola, its licensors, and other 3rd Party supplied software certain exclusive rights for copyrighted material, including the exclusive right to copy, reproduce in any form, distribute and make derivative works of the copyrighted material. Accordingly, any copyrighted material of Motorola, its licensors, or the 3rd Party software supplied material contained in the Motorola products described in this document may not be copied, reproduced, reverse engineered, distributed, merged or modified in any manner without the express written permission of Motorola. Furthermore, the purchase of Motorola products shall not be deemed to grant either directly or by implication, estoppel, or otherwise, any license under the copyrights, patents or patent applications of Motorola or other 3rd Party supplied software, except for the normal non-exclusive, royalty free license to use that arises by operation of law in the sale of a product.

A list of 3rd Party supplied software copyrights are contained in the Supplemental information section of this document.

Restrictions

Software and documentation are copyrighted materials. Making unauthorized copies is prohibited by law. No part of the software or documentation may be reproduced, transmitted, transcribed, stored in a retrieval system, or translated into any language or computer language, in any form or by any means, without prior written permission of Motorola, Inc.

License Agreements

The software described in this document is the property of Motorola, Inc and its licensors. It is furnished by express license agreement only and may be used only in accordance with the terms of such an agreement.

High Risk Materials

Components, units, or 3rd Party products used in the product described herein are NOT fault-tolerant and are NOT designed, manufactured, or intended for use as on-line control equipment in the following hazardous environments requiring fail-safe controls: the operation of Nuclear Facilities, Aircraft Navigation or Aircraft Communication Systems, Air Traffic Control, Life Support, or Weapons Systems (High Risk Activities). Motorola and its supplier(s) specifically disclaim any expressed or implied warranty of fitness for such High Risk Activities.

Trademarks



MOTOROLA

Motorola and the Stylized M Logo are registered in the US Patent & Trademark Office. All other product or service names are the property of their respective owners.



The CE mark confirms Motorola, Inc. statement of compliance with EU directives applicable to this product. Copies of the Declaration of Compliance and installation information in accordance with the requirements of EN50385 can be obtained from the local Motorola representative or by contacting the Customer Network Resolution Center (CNRC). The 24 hour telephone numbers are listed at <https://mynetworksupport.motorola.com>. Select **Customer Network Resolution Center contact information**. Alternatively if you do not have access to CNRC or the internet, contact the Local Motorola Office.

Contents

R20 1X UBS Macro BTS Hardware Installation

Revision history	3
Version information	3
Resolution of Service Requests	3
Incorporation of Change Notices	3
General information	4
Purpose	4
Cross references	4
Text conventions	5
Contacting Motorola	6
24-hour support	6
Questions and comments	6
Errors	6
Security advice	7
Warnings, cautions, and notes	8
Warnings	8
Cautions	8
Notes	8
Safety	9
General safety	9
Electromagnetic energy	9
Caring for the environment	10
In EU countries	10
In non-EU countries	10
CMM labeling and disclosure table	11
Motorola document set	12
Ordering documents and CD-ROMs	12
Document banner definitions	12
Data encryption	12
Third Party Computer Software and Trademarks	13
Computer Software	13
Trademarks	13

Chapter 1: Introduction and Frame Identification

Abbreviations and Acronyms	1-2
Abbreviations and Acronyms	1-2
Overview	1-5
Scope of manual	1-5
Prerequisites	1-5
Chapter 1 - Introduction and frame identification	1-5
Chapter 2 – UBS Macro BTS installation procedure	1-6
Chapter 3 - Low-to-Mid Capacity Frame Expansion Procedures	1-6

- Chapter 4 - What's next 1-6
- Equipment shipped assembled. 1-6
- Equipment shipped un-assembled 1-6
- Follow the task sequence 1-7
- Follow the site plan 1-7
- Site cleanliness 1-7
- Site manager. 1-7
- Color coding 1-7
- Rack vs. frame 1-8
- Required documentation. 1-8
- Equipment may vary from figures 1-8
- Item identification 1-9
- UBS Macro BTS frames 1-9
- Items to be installed 1-15
- Tools and materials 1-16
- Required tools and materials. 1-16
- Recommended tools 1-17
- Unpacking Instructions 1-18
- Unpacking the carrier strip assembly 1-18
- Unpacking accessory equipment. 1-20

Chapter 2: UBS Macro BTS Installation Procedure

- Overview. 2-2
- Introduction 2-2
- Structural engineer 2-2
- Required items. 2-2
- Cabling and configuration options 2-2
- Color coding 2-2
- Cable list, diagrams and connectors 2-4
- Overview. 2-4
- UBS Macro BTS external I/O cable run list 2-4
- Connector locations 2-6
- Full installation sequence 2-11
- Overview. 2-11
- Prerequisites. 2-11
- Verifying site and equipment. 2-11
- Physical installation 2-11
- Site verification 2-15
- Site installation checks 2-15
- Temperature range 2-16
- Frame physical dimensions 2-16
- Frame clearances 2-16
- Frame DC input power and power cabling information 2-17
- Frame positioning 2-18
- Rack base description and dimensions. 2-18
- Task 1: Installing RGPS Head 2-20
- Objective. 2-20
- RGPS head installation. 2-20
- Tasks 2-3: Installing Rack & Ground Cable 2-28
- Objectives 2-28
- Rack requirements. 2-28
- Structural engineer prerequisite. 2-28
- Required items. 2-29
- Location of rack earth ground terminals 2-30
- Procedure 2-30
- Task 4: Rack Mounting the Optional PSM Shelf 2-32
- Objectives 2-32

- Required items 2-32
- Procedure 2-32
- Procedural reference diagrams 2-34
- Task 5: Rack Mounting for Low-Capacity Frame 2-36
 - Objective. 2-36
 - Required items. 2-36
 - Procedure 2-37
 - Procedural reference diagrams 2-38
- Task 6: Expanding the Low-capacity Frame 2-42
 - Objective. 2-42
 - Procedure 2-42
- Task 7: Cabling the Optional PSM Shelf 2-43
 - Objectives 2-43
 - Required items. 2-43
 - Procedure 2-43
- Tasks 8-9: Connecting TX/RX Antennas 2-44
 - Objectives 2-44
 - Required items. 2-44
 - Location of antenna connectors 2-44
 - Procedure 2-44
- Tasks 10-13: Connecting RGPS, Spans, Customer Alarms 2-46
 - Objectives 2-46
 - Cabling options 2-46
 - Required items. 2-47
 - Location of cables AA, W and X 2-47
 - Balanced T1/E1 cable (W) details 2-47
 - Customer alarm input/output (IP/OP) cable (X) details. 2-49
- Task 14: Connecting +27 V DC Power 2-55
 - Objectives 2-55
 - Frame power cables and connector information 2-55
 - Required items. 2-56
 - Power cabling and tie down requirements 2-57
 - Contact/lug, DC connector housing and PDU input power 2-57
 - Procedure 2-58
- Task 15: Connecting -48 V DC Power 2-60
 - Objectives 2-60
 - Frame power cables and connector information 2-60
 - Required items. 2-61
 - Power cabling and tie down requirements 2-62
 - Contact/lug, DC connector housing and PDU input power 2-62
 - Procedure 2-63
- Task 16: Connecting 220 V AC Power 2-65
 - Objectives 2-65
 - Frame AC power cables and wiring information 2-65
 - Required items. 2-66
 - AC PSM shelf AC power input detail 2-66
 - Procedure 2-68

Chapter 3: Low-to-Mid Capacity Frame Expansion Procedures

- Low-to-Mid Capacity Frame Expansion Overview 3-2
 - How to use this chapter 3-2
- Adding Circuit Breakers/Connectors to PDU 3-3
 - Objective. 3-3
 - Required items. 3-3
 - Procedure 3-4
 - Procedural reference diagram 3-6
- Adding an XMI 3-7

- Objective. 3-7
- Required items. 3-7
- Procedure 3-8
- Procedural reference diagram 3-9
- Adding a DMI 3-11
 - Objective. 3-11
 - Required items. 3-11
 - Prerequisite 3-12
 - Procedure 3-12
 - Procedural reference diagram 3-14
- Adding a Second Set of IDRFs 3-15
 - Objective. 3-15
 - Required items. 3-15
 - Procedure 3-16
 - Procedural reference diagram 3-17
- Adding an Optional RX Splitter 3-18
 - Objective. 3-18
 - Required items. 3-18
 - Procedure 3-18
 - Procedural reference diagram 3-19
- Adding a third PSM (-48 V or 220 V AC only) 3-20
 - Objective. 3-20
 - Required items. 3-20
 - Procedure 3-21
- Mid-capacity Expansion Interconnect Cabling 3-22
 - Objective. 3-22
 - Installing DC power cables. 3-22
 - Installing/Connecting RF cables (XMI to IDRF) 3-25
 - Installing XMI to DMI cables. 3-28
 - Installing DMI to SSI cables 3-29
 - Installing RX splitter to XMI RX RF cables or RX share cable 3-30

Chapter 4: What’s Next

- Installation completion. 4-2
 - Clean up the site 4-2
 - Fill out the installation completion checklist 4-3
 - Record “As-Built” information 4-4
 - Performing the ATPs 4-4
 - Loading the software 4-4

List of Figures

Figure 1-1: UBS Macro BTS low-tier/low-capacity frame (1000 mm rack)	1-10
Figure 1-2: Low capacity UBS Macro BTS starter frame (1800 mm rack)	1-11
Figure 1-3: UBS Macro BTS mid-capacity frame (1800 mm rack)	1-12
Figure 1-4: High capacity 800 MHz UBS Macro BTS fully expanded frame (1800 mm rack) . . .	1-13
Figure 1-5: High-capacity 1.9 GHz UBS Macro BTS fully expanded frame (1800 mm rack) . . .	1-14
Figure 1-6: Items to install.	1-15
Figure 1-7: Carrier strip assembly with inner carton support	1-19
Figure 1-8: Carrier strip assembly with inner carton support removed	1-19
Figure 2-1: 800 MHz IDRf I/O connectors	2-7
Figure 2-2: 1.9 GHz IDRf I/O connectors	2-7
Figure 2-3: SSI front panel connectors.	2-9
Figure 2-4: PSM shelf front panel connectors	2-10
Figure 2-5: Rack footprint	2-19
Figure 2-6: RGPS cabling diagram.	2-21
Figure 2-7: RGPS wiring	2-22
Figure 2-8: RGPS lightning arrestor wiring	2-23
Figure 2-9: RGPS heads	2-24
Figure 2-10: Installing the RGPS head.	2-25
Figure 2-11: Connector pin numbering for cables NN and AA	2-26
Figure 2-12: Location of ground terminals on a Motorola rack.	2-30
Figure 2-13: Hanger screw layout for the optional PSM shelf	2-34
Figure 2-14: Hanging the PSM shelf.	2-35
Figure 2-15: Hanger screw layout for UBS Macro carrier strip assembly	2-39
Figure 2-16: Lifting and hanging the carrier strip assembly on the rack.	2-40
Figure 2-17: Carrier strip assembly keyhole screw locations	2-41
Figure 2-18: T1/E1 balanced span line cable (W) pin numbering.	2-47
Figure 2-19: Customer alarm cable (X) pin numbering.	2-51
Figure 2-20: +27 V DC power input cable (DC) wire tie-wrap example	2-57
Figure 2-21: +27 V DC power input cable (DC) connector and connection to PDU.	2-58
Figure 2-22: 48 V DC power input cable (CC) wire tie-wrap example	2-62
Figure 2-23: 48 V DC power input cable (CC) connector and connection to PSM shelf.	2-63
Figure 2-24: AC PSM shelf AC power input terminal block and wiring details	2-67
Figure 3-1: Adding a Breaker Assembly Module to the PDU	3-6
Figure 3-2: Installing a 2nd XMI	3-10
Figure 3-3: Installing a 2nd DMI.	3-14
Figure 3-4: Installing the second set of IDRfS	3-17
Figure 3-5: Mounting the RX splitter	3-19

List of Tables

Table 1: Manual version history	3
Table 1-1: Abbreviations and Acronyms	1-2
Table 2-1: Color code – DC power connectors/cables	2-3
Table 2-2: Color code - RF Equipment and Connectors/Cables	2-3
Table 2-3: UBS Macro BTS external I/O cable run list	2-4
Table 2-4: Frame dimensions	2-16
Table 2-5: Minimum frame clearances for airflow	2-16
Table 2-6: Minimum frame clearances for maintenance - front access only	2-16
Table 2-7: Minimum frame clearances for maintenance - front and rear access	2-17
Table 2-8: +27 V DC and –48 V DC Frame Power Cabling and Power Supply Breaker Information	2-17
Table 2-9: List of required cables for RGPS head installation	2-20
Table 2-10: Pinout for cables NN and AA	2-26
Table 2-11: T1/E1 I/O cable W (span) signal and pin information	2-48
Table 2-12: Customer alarm cable (X) pinout for customer IP 1-12 OP 1-4	2-51
Table 2-13: Customer alarm cable (X) pinout for customer IP 13-24 OP 5-8	2-52
Table 2-14: +27 V DC connector (Orange) parts information	2-55
Table 2-15: –48 V DC connector (Blue) parts information	2-61
Table 4-1: Installation completion checklist	4-3

R20 1X UBS Macro BTS Hardware Installation



NOTE

The R20 UBS Macro BTS supports single band 800 MHz or 1.9 GHz RF band, up to two XMIs, up to two DMIs and one SSI. UBS Macro BTS frame configurations with up to four XMIs and up to five DMIs will be available in the future.

What is covered in this manual?

The UBS Macro BTS Hardware Installation manual describes the installation of Motorola supported configurations of the UBS Macro BTS system. The UBS Macro BTS system supports either the 800 MHz or the 1.9 GHz RF band and IP-packet backhaul. In addition, CDMA 1X and CDMA EV-DO channels are supported as well as Open Transport Interface (OTI) for IP-packet backhaul via Ethernet. The UBS Macro BTS frame can also be configured for +27 V DC operation, optional -48 V DC or optional 220 V AC operation.

The UBS Macro BTS air interface supports the following:

- Omni or 3-sector antenna configurations
- Single RF band operation only; 800 MHz or 1.9 GHz RF band
- Up to 120 W of total TX RF power output and up to 30 W TX RF power output per carrier
- Dual path, Main and Diversity, RX antennas

UBS Macro BTS frames are also configured for low, mid, or high capacity. Capacity is determined by the quantity of sector carriers and traffic channels supported by the frame. The quantity of sector carriers is a function of the quantity of XMIs. The quantity of traffic channels is a function of the quantity of modems. Because the modems are inside the DMI, the quantity of DMIs is a capacity factor. The capacity of a UBS Macro BTS frame is essentially based on the following:

- low capacity - one XMI and up to two DMIs
- mid capacity - two XMIs and two DMIs
- high capacity - more than two XMIs (four XMIs maximum) and more than two DMIs (five DMIs maximum)

For Software Release 2.20.x, only low and mid capacity frames are available/supported.



NOTE

High capacity UBS Macro BTS frames will be available in the future.

The manual covers the following topics:

- Chapter 1 provides a brief description of the information presented in the manual, frame identification information, installation sequence, and a list of tools.
- Chapter 2 provides illustrations displaying the location of all UBS Macro connectors for external cabling and wiring purposes, external cable run list, and a detailed installation sequence. Installation procedures cover mounting items to the rack and installing the external cabling.
- Chapter 3 provides information and procedures needed for expanding the low-capacity UBS Macro BTS starter/expansion frame to the mid-capacity frame configuration.
- Chapter 4 provides procedures for cleaning up the site and the installation completion checklist.

Revision history

The following shows the issue status of this manual since it was first released.

Version information

Table 1 Manual version history

Manual issue	Date of issue	Remarks
1	JUN 15, 2007	DRAFT version for SME review
2	AUG 10, 2007	PRELIMINARY version for SME review. Does not include E-GPS and the special recently requested SPRINT mechanics.
3	AUG 31, 2007	PRELIMINARY version for Deployment. Does not include E-GPS and the special recently requested SPRINT mechanics.

Resolution of Service Requests

The following Service Requests are resolved in this document:

Service Request	CMBP Number	Remarks
NA	NA	NA

Incorporation of Change Notices

The following Change Notices (CN) are incorporated in this document:

CN Date	CN Number	Title
NA	NA	NA

General information

Purpose

Motorola cellular communications documents are intended to instruct and assist personnel in the operation, installation and maintenance of the Motorola cellular infrastructure equipment and ancillary devices. It is recommended that all personnel engaged in such activities be properly trained by Motorola.

Motorola disclaims all liability whatsoever, implied or express, for any risk of damage, loss or reduction in system performance arising directly or indirectly out of the failure of the customer, or anyone acting on the customer's behalf, to abide by the instructions, system parameters, or recommendations made in this document.

These documents are not intended to replace the system and equipment training offered by Motorola. They can be used to supplement and enhance the knowledge gained through such training.



NOTE

If this document was obtained when attending a Motorola training course, it will not be updated or amended by Motorola. It is intended for TRAINING PURPOSES ONLY. If it was supplied under normal operational circumstances, to support a major software release, then corrections are supplied automatically by Motorola and posted on the Motorola customer website.

Cross references

References made to external publications are shown in italics. Other cross references, emphasized in blue text in electronic versions, are active links to the references.

This document is divided into numbered chapters that are divided into sections. Sections are not numbered, but are individually named at the top of each page, and are listed in the table of contents.

Text conventions

The following conventions are used in the Motorola cellular infrastructure documents to represent keyboard input text, screen output text, and special key sequences.

Input

Characters typed in at the keyboard are shown like this.

Items of interest within a command appear like this.

Output

Messages, prompts, file listings, directories, utilities, and environmental variables that appear on the screen are shown like this.

Items of interest within a screen display appear like this.

Special key sequences

Special key sequences are represented as follows:

CTRL-c or CTRL+C	Press the Ctrl and C keys at the same time.
CTRL-SHIFT-c or CTRL+SHIFT+C	Press the Ctrl , Shift , and C keys at the same time.
ALT-f or ALT+F	Press the Alt and F keys at the same time.
ALT+SHIFT+F11	Press the Alt , Shift and F11 keys at the same time.
	Press the pipe symbol key.
RETURN or ENTER	Press the Return or Enter key.

Contacting Motorola

Motorola appreciates feedback from the users of our documents.

24-hour support

If you have problems regarding the operation of your equipment, contact the Customer Network Resolution Center (CNRC) for immediate assistance. The 24-hour telephone numbers are listed at <https://mynetworksupport.motorola.com>. Select **Customer Network Resolution Center contact information**. Alternatively if you do not have access to CNRC or the internet, contact the Local Motorola Office.

Questions and comments

Send questions and comments regarding user documentation to the email address: mydocs@motorola.com.

Errors

To report a documentation error, call the CNRC (Customer Network Resolution Center) and provide the following information to enable CNRC to open an SR (Service Request):

- The document type
- The document title, part number, and revision character
- The page number with the error
- A detailed description of the error and if possible the proposed solution

Security advice

Motorola systems and equipment provide security parameters that can be configured by the operator based on their particular operating environment. Motorola recommends setting and using these parameters following industry recognized security practices. Security aspects to be considered are protecting the confidentiality, integrity, and availability of information and assets. Assets include the ability to communicate, information about the nature of the communications, and information about the parties involved.

In certain instances, Motorola makes specific recommendations regarding security practices. The implementation of these recommendations and final responsibility for the security of the system lies with the operator of the system.

Contact the Customer Network Resolution Center (CNRC) for assistance. The 24-hour telephone numbers are listed at <https://mynetworksupport.motorola.com>. Select **Customer Network Resolution Center contact information**, from the menu located to the left of the Login box. Alternatively if you do not have access to CNRC or the internet, contact the Local Motorola Office.

Warnings, cautions, and notes

The following describes how warnings and cautions are used in this document and in all documents of this Motorola document set.

Warnings

Warnings precede instructions that contain potentially hazardous situations. Warnings are used to alert the reader to possible hazards that could cause loss of life or physical injury. A warning has the following format:



WARNING

Warning text and consequence for not following the instructions in the warning.

Cautions

Cautions precede instructions and are used when there is a possibility of damage to systems, software, or individual items of equipment within a system. However, this damage presents no danger to personnel. A caution has the following format:



CAUTION

Caution text and consequence for not following the instructions in the caution.

Notes

A note means that there is a possibility of an undesirable situation or provides additional information to help the reader understand a topic or concept. A note has the following format:



NOTE

Note text.

Safety

General safety

The following general safety guidelines apply to Motorola equipment:

- The power jack and mating plug of the power cable must meet International Electrotechnical Commission (IEC) safety standards.



NOTE

Refer to *Grounding Guideline for Cellular Radio Installations – 68P81150E62*.

- Power down or unplug the equipment before servicing.
- Using non-Motorola parts for repair could damage the equipment or void warranty. Contact Motorola Warranty and Repair for service and repair instructions.
- Portions of Motorola equipment may be damaged from exposure to electrostatic discharge. Use precautions to prevent damage.

Electromagnetic energy

Relevant standards (USA and EC) applicable when working with RF equipment are:

- *ANSI IEEE C95.1-1991, IEEE Standard for Safety Levels with Respect to Human Exposure to Radio Frequency Electromagnetic Fields, 3 kHz to 300 GHz.*
- Council recommendation of 12 July 1999 on the limitation of exposure of the general public to electromagnetic fields (0 Hz to 300 GHz) (1999/519/EC) and respective national regulations.
- *Directive 2004/40/EC of the European Parliament and of the Council of 29 April 2004 on the minimum health and safety requirements regarding the exposure of workers to the risks arising from physical agents (electromagnetic fields) (18th individual Directive within the meaning of Article 16(1) of Directive 89/391/EEC).*

Caring for the environment

The following information describes national or regional requirements for the disposal of Motorola supplied equipment and for the approved disposal of surplus packaging.

Contact the Customer Network Resolution Center (CNRC) for assistance. The 24-hour telephone numbers are listed at <https://mynetworksupport.motorola.com>. Select **Customer Network Resolution Center contact information**. Alternatively if you do not have access to CNRC or the internet, contact the Local Motorola Office.

In EU countries

The following information is provided to enable regulatory compliance with the European Union (EU) directives identified and any amendments made to these directives when using Motorola equipment in EU countries.



Disposal of Motorola equipment

European Union (EU) Directive 2002/96/EC Waste Electrical and Electronic Equipment (WEEE)

Do not dispose of Motorola equipment in landfill sites. In the EU, Motorola in conjunction with a recycling partner ensures that equipment is collected and recycled according to the requirements of EU environmental law.

Disposal of surplus packaging

European Parliament and Council Directive 94/62/EC Packaging and Packaging Waste

Do not dispose of surplus packaging in landfill sites. In the EU, it is the individual recipient's responsibility to ensure that packaging materials are collected and recycled according to the requirements of EU environmental law.

In non-EU countries

In non-EU countries, dispose of Motorola equipment and all surplus packaging in accordance with national and regional regulations.

CMM labeling and disclosure table

The People’s Republic of China require that our products comply with China Management Methods (CMM) environmental regulations. (China Management Methods refers to the regulation *Management Methods for Controlling Pollution by Electronic Information Products*.) Two items are used to demonstrate compliance; the label and the disclosure table.

The label is placed in a customer visible position on the product.

- Logo 1 means the product contains no substances in excess of the maximum concentration value for materials identified in the China Management Methods regulation.
- Logo 2 means that the product may contain substances in excess of the maximum concentration value for materials identified in the China Management Methods regulation, and has an Environmental Friendly Use Period (EFUP) in years, fifty years in the example shown.



The Environmental Friendly Use Period (EFUP) is the period (in years) during which the Toxic and Hazardous Substances (T&HS) contained in the Electronic Information Product (EIP) will not leak or mutate causing environmental pollution, or bodily injury from the use of the EIP. The EFUP indicated by the Logo 2 label applies to a product and all its parts. Certain field-replaceable parts, such as battery modules, can have a different EFUP and are marked separately.

The Disclosure table is intended only to communicate compliance with China requirements. It is not intended to communicate compliance with EU RoHS or any other environmental requirements.

Disclosure table

部件名称	有毒有害物质或元素					
	铅 (Pb)	汞 (Hg)	镉 (Cd)	六价铬 (Cr ⁶⁺)	多溴联苯 (PBB)	多溴二苯醚 (PBDE)
金属部件	×	○	×	×	○	○
电路模块	×	○	×	×	○	○
电缆及电缆组件	×	○	×	×	○	○
塑料和聚合物部件	○	○	○	○	○	×

○： 表示该有毒有害物质在该部件所有均质材料中的含量均在 SJ/T11363-2006 标准规定的限量要求以下。
 ×： 表示该有毒有害物质至少在该部件的某一均质材料中的含量超出SJ/T11363-2006 标准规定的限量要求。

Motorola document set

The Motorola document sets provide the information to operate, install, and maintain the Motorola equipment.

Ordering documents and CD-ROMs

With internet access available, to view, download, or order documents (original or revised), visit the Motorola Lifecycles Customer web page at <https://mynetworksupport.motorola.com>, or contact your Motorola account representative.

Without internet access available, order hard copy documents or CD-ROMs with your Motorola Local Office or Representative.

If Motorola changes the content of a document after the original printing date, Motorola publishes a new version with the same part number but a different revision character.

Document banner definitions

A banner (oversized text on the bottom of the page, for example, **PRELIMINARY — UNDER DEVELOPMENT**) indicates that some information contained in the document is not yet approved for general customer use.

Data encryption

In order to avoid electronic eavesdropping, data passing between certain elements in the network is encrypted. In order to comply with the export and import requirements of particular countries, this encryption occurs at different levels as individually standardized, or may not be present at all in some parts of the network in which it is normally implemented. The document set, of which this document is a part, covers encryption as if fully implemented. Because the rules differ in individual countries, limitations on the encryption included in the particular software being delivered, are covered in the Release Notes that accompany the individual software release.

Third Party Computer Software and Trademarks

Computer Software

The Motorola and 3rd Party supplied Software (SW) products described in this instruction manual may include copyrighted Motorola and other 3rd Party supplied computer programs stored in semiconductor memories or other media. Laws in the United States and other countries preserve for Motorola and other 3rd Party supplied SW certain exclusive rights for copyrighted computer programs, including the exclusive right to copy or reproduce in any form the copyrighted computer program. Accordingly, any copyrighted Motorola or other 3rd Party supplied SW computer programs contained in the Motorola products described in this instruction manual may not be copied (reverse engineered) or reproduced in any manner without the express written permission of Motorola or the 3rd Party SW supplier. Furthermore, the purchase of Motorola products shall not be deemed to grant either directly or by implication, estoppel, or otherwise, any license under the copyrights, patents or patent applications of Motorola or other 3rd Party supplied SW, except for the normal non-exclusive, royalty free license to use that arises by operation of law in the sale of a product.

Vendor	Copyright
Apache Software Foundation	Copyright 2002-2003 All Rights Reserved
Artesyn	Copyright 2002-2003 All Rights Reserved
CMU *	Copyright 2002-2003 All Rights Reserved
Freeware Tools / Utilities *	Copyright 2002-2003 All Rights Reserved
Performance Technologies	Copyright 2002-2003 All Rights Reserved
Telelogic	Copyright 2002-2003 All Rights Reserved
QNX *	Copyright 2002-2003 All Rights Reserved

*= Freeware

Trademarks

Java™ Technology and/or J2ME™ : Java and all other Java-based marks are trademarks or registered trademarks of Sun Microsystems, Inc. in the U.S. and other countries.

UNIX® : UNIX is a registered trademark of The Open Group in the United States and other countries.

Introduction and Frame Identification

Abbreviations and Acronyms

Abbreviations and Acronyms

Table 1-1 identifies the equipment related abbreviations and acronyms used in this manual.

Table 1-1 Abbreviations and Acronyms

Acronym	Definition
1X	One of two bandwidths currently defined in the IS-2000 CDMA specification, which extends the capability of the IS-95A and B specifications. 1X bandwidth provides wireless packet voice and data transmission capability at up to 144 Kbps.
A	Ampere or Amp
AC	Alternating Current
ACC	Accessory
AN	Aggregation Node
ATP	Acceptance Test Plan
AWG	American Wire Gauge
BMA	Breaker Module Assembly
BSI	Baseband Switch Interface
BSS	Base Station System
BSSAN	Base Station System (BSS) Access Network. The BSSAN consists of a Radio Access Network (RAN) and an AN. It may also include a Digital Access and Cross-connect System to support split backhaul and a Selector Distribution Unit (SDU).
BTS	Base Transceiver Station or Base Transceiver Subsystem
CB	Circuit Breaker
CBSC	Centralized Base Station Controller
CCW	Counter Clockwise
CDMA	Code Division Multiple Access
CE	Channel Element
CW	Clockwise
DC	Direct Current
DIV	Diversity
DMI	Digital Module Internal
DMM	Digital Multi-Meter

Continued

Table 1-1 Abbreviations and Acronyms (Continued)

Acronym	Definition
E-GPS	External-GPS
ESD	Electro-Static Discharge
EV-DO	CDMA 1X Evolution - Data Only
FRU	Field Replaceable Unit
FWD	Forward
GND	Ground
GPS	Global Positioning System
HSO	High Stability Oscillator
IDI	Interworking DMI Interconnect
IDRF	Integrated Duplexer RX Filter
I/O	Input/Output
IP	Internet Protocol
IP/OP	Customer Alarm Input/Output
IS	Interim Standard
LAN	Local Area Network
LMF	Local Maintenance Facility
LMT	Local Maintenance Terminal
MGB	Master Ground Bar
MMI	Man Machine Interface
MMII	Mobility Manager II
MSN	Mobile Switching Network
MSO	Motorola Standard Oscillator
OMC-IP	Operations Maintenance Center - Internet Protocol
OMC-R	Operations Maintenance Center - Radio
PA	Power Amplifier
PBH	Packet Backhaul: IP-based backhaul between the BTS and the network. The UBS Macro BTS is configured for packet backhaul operation.
PC	Power Connector
PDU	Power Distribution Unit
PPS or 1PPS	1 pulse per second
PSM	Power Supply Module
QHSO	Quartz High Stability Oscillator
RAN	Radio Access Network
RF	Radio Frequency

Continued

Table 1-1 Abbreviations and Acronyms (Continued)

Acronym	Definition
RFL	Reflected
RGPS	Remote Global Positioning System
RU	Rack Unit
RX	Receive or Receiver
SDU	Selection and Distribution Unit
SPROC	Site Processor
SSI	Site Span I/O or Site/Span Interface
TCH	Traffic Channel
TX	Transmit or Transmitter
UBS	Universal Base Station
UNO	Universal Network Operations
V	Volt
VPU	Vocoder Processing Unit
W	Watt
XMI	Transceiver Module Internal

Overview

Scope of manual

This manual covers how to:

- Mount the equipment rack to the floor.
- Mount the pre-assembled/pre-cabled UBS Macro equipment on to the rack.
- Mount the optional power supply equipment on to the rack and install all of the associated interconnect cabling.
- Mount the low-to-mid capacity expansion equipment on to the rack and install all of the associated interconnect cabling.
- Install external cabling and wiring between the rack mounted UBS Macro equipment and other BTS site equipment.

This manual is not intended to be used as a planning guide. All site plans and site specific information must be decided, before starting the installation. The site specific information determines the configuration to be used and the items and cabling required to support that configuration.

This manual may be used in conjunction with site-specific configuration planning to determine the site-specific expansion.

This manual does not provide information for the Acceptance Test Procedures (ATP) or software loading.

Prerequisites

The following are the three major prerequisites:

- The procedure, tools, and equipment required for mounting the rack to the floor has been specified by a Structural Engineer.
- All site preparations (including power) have been completed according to the site plan.
- All site planning and BTS configuration information is available.

Chapter 1 - Introduction and frame identification

This chapter provides a brief description of the information presented in the manual, frame identification information, installation sequence, and a list of tools.

Chapter 2 – UBS Macro BTS installation procedure

This chapter provides figures showing the location of all UBS Macro connectors for external cabling and wiring purposes, external cable run list, and a detailed installation sequence. Installation procedures cover mounting items to the rack and installing the external cabling.

Chapter 3 - Low-to-Mid Capacity Frame Expansion Procedures

This chapter provides information and procedures needed for expanding the low-capacity UBS Macro BTS starter/expansion frame to the mid-capacity frame configuration.

Chapter 4 - What's next

This chapter provides procedures for cleaning up the site and the installation completion checklist.

Equipment shipped assembled

The low-capacity, +27 V DC UBS Macro BTS is shipped pre-assembled on carrier strips with all internal cabling installed. This pre-assembled equipment is delivered in a crate. After the crate is unpacked, the low-capacity +27 V DC UBS Macro BTS assembly is ready to be rack mounted. The carrier strips allow four people to carefully lift the assembly off the crate packing onto the rack. The assembly can also be lifted via some mechanical aid (hoist, etc.) attached to the lifting loops on the ends of the carrier strips. The carrier strips also provide easy rack mounting. After the UBS Macro equipment is rack mounted, cables are connected between the UBS Macro equipment and external site inputs/outputs.

Equipment shipped un-assembled

The low-to-mid capacity expansion equipment and associated cables are shipped in separate individual containers. The additional expansion equipment is mounted into the low-capacity frame and then the associated interconnect cables are installed.

For -48 V DC or 220 V AC UBS Macro BTS applications, either a -48 V DC or a 220 V AC PSM (Power Supply Module) shelf is required. The PSM shelf comes assembled, but without PSMs installed in the shelf. For a low capacity frame, either two -48 V DC or two 220 V AC PSMs are installed in the shelf. The second PSM is for redundancy. The PSM shelf without PSMs is delivered in a single box. Each PSM is delivered in a single box. The PSM shelf is mounted at the bottom of the rack. Then the PSMs are installed in the PSM shelf. The +27 V DC UBS Macro assembly is mounted just above the PSM shelf. The PSM +27 V DC output cable is connected to the +27 V DC input cable on the +27 V DC UBS Macro assembly. The site -48 V DC or 220 V AC power source is cabled/wired to the PSM shelf.

The Remote GPS (RGPS) head and associated cable are shipped un-assembled. The cable has to be connected to the RGPS head along with the customer supplied mounting mast.

Most of the cable/wire connectors that are required to connect with the UBS Macro equipment external site input/output connectors are supplied, but need to be assembled onto cables/wires. Most of the cables/wires are supplied by the customer.

Follow the task sequence

The installation of the BTS is a defined sequence where one task relies on the previous task being completed. Figures are used to aide in understanding cable and item placement.

Follow the site plan

Items and cables are covered in the installation procedure that may not apply to a specific site configuration. Refer to the site plan to determine which items and cables are to be installed. Skip over those procedures for items and cables that are not required.

Site cleanliness

While performing the procedures provided in this document, ensure that:

- The site is kept clean and free of dirt. Dust can circulate in the air for several days and settle on all horizontal surfaces. Site equipment cooling fans can draw in dust particles, causing damage to electrical contacts.
- All packing materials are removed from the equipment.
- All the tools that are not currently in use are picked-up as the installation progresses.
- All trash is removed from the site at the end of each day and after the installation is complete.
- Equipment is covered with tarpaulin whenever possible.
- A shop vacuum is used, when a procedure is performed that generates dust, such as drilling or cutting.

Site manager

The site manager is in-charge of and responsible for the full site. The installer verifies a variety of conditions with the site manager.

Color coding

Many of the RF connectors and cables are color coded. When the cables are installed, the cable color code should match the color code of the connector.

The +27 V DC input/output cable connectors are color coded Orange while the -48 V DC input/output cable connectors are color coded Blue. When these power connections are made, make sure that the color of the mating connectors match.

**NOTE**

- Not all cables and connectors are color coded.
- Some, but not all, of the color coding is called out in the installation procedures.

Rack vs. frame

For purposes of this manual, the Rack is the piece of iron (metal) that the items are mounted on. The Frame is the Rack with all the items mounted on it.

Required documentation

The following additional documents are required to install the BTS:

- *Grounding Guidelines for Cellular Radio Installations (Motorola part number 68P81150E62)*
- *Site description* (as built) documents
- *Demarcation (Scope of Work Agreement)* document
- *Equipment manuals* for non-Motorola equipment including:
 - c *Acutime™ Gold GPS Smart Antenna Kit User Guide* — Supplied with STLN6594 RGPS Head.
- *UBS (800 MHz) BTS Specification (B1)* or *UBS (1.9 GHz) BTS Specification (B1)* document, whichever is applicable.

Equipment may vary from figures

The equipment shown in many of the figures is typical. The actual equipment appearance may vary slightly.

Item identification



NOTE

The R20 UBS Macro BTS supports single band 800 MHz or 1.9 GHz RF band, up to two XMIs, up to two DMIs and one SSI. UBS Macro BTS frame configurations with up to four XMIs and up to five DMIs will be available in the future.

UBS Macro BTS frames

UBS Macro BTS frames are configured for either +27 V DC operation, -48 V DC operation, or 220 V AC operation.

UBS Macro BTS frames are also configured for low, mid or high capacity. Low capacity frames, like the starter frame shown in [Figure 1-2](#), can be expanded to add more capacity. Mid-capacity frames, like the frame shown in [Figure 1-3](#), can be expanded to add more capacity. A high capacity frame, like the expanded frames shown in [Figure 1-4](#) and [Figure 1-5](#) can be expanded to add more capacity, if it is not already fully expanded. A BTS site with a fully expanded high capacity frame may be further expanded by adding a second frame for more capacity.



NOTE

High capacity UBS Macro BTS frames and BTS sites with multiple UBS Macro BTS frames are not currently available.

Figure 1-1 shows a UBS Macro BTS low-tier/low-capacity frame. The capacity of this configuration is not expandable.

Figure 1-1 UBS Macro BTS low-tier/low-capacity frame (1000 mm rack)

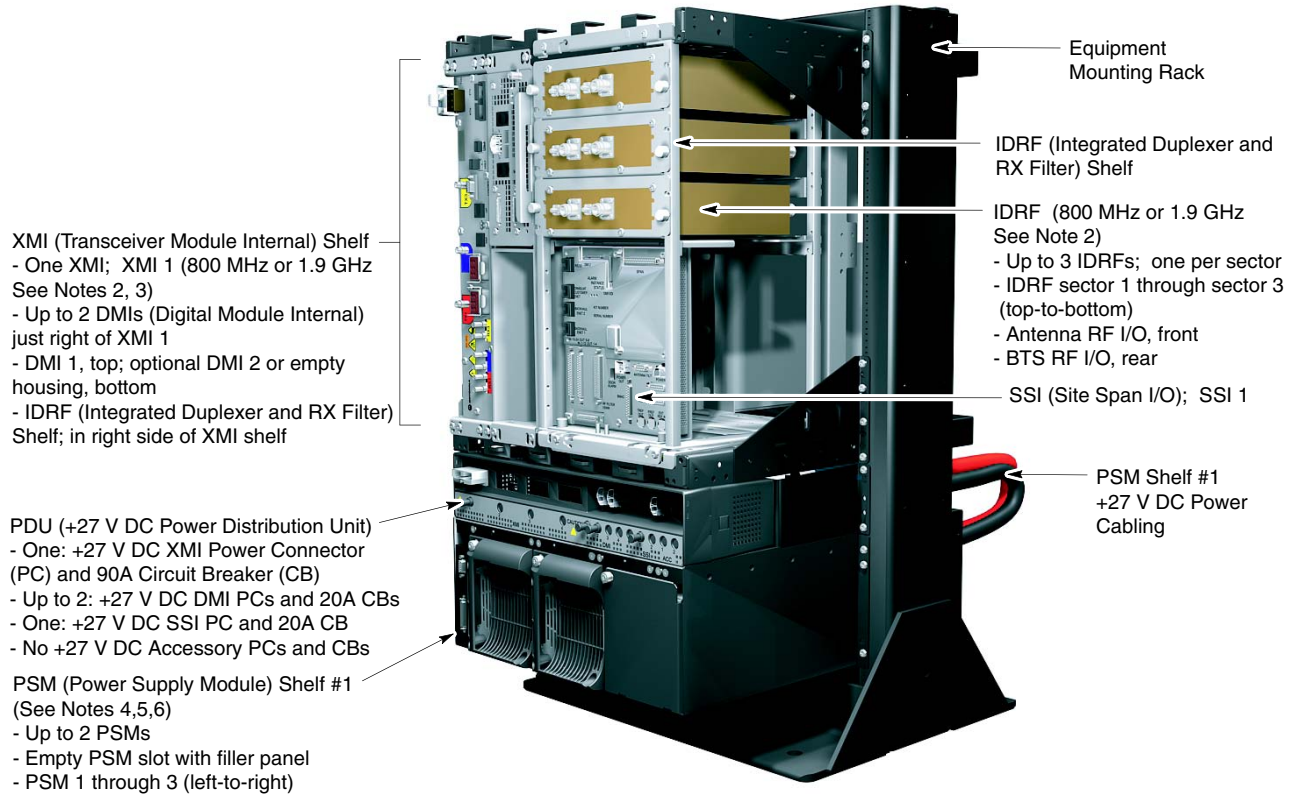

NOTES:

1. Interconnect cabling not shown for clarity.
2. 800 MHz equipment shown; 1.9 GHz similar.
3. 800 MHz XMI is 86 mm wide. 1.9 GHz XMI is 106.3 mm wide.
4. PSM shelf is optional and used instead of +27 V DC power Input.
5. PSM shelf is either -48 V DC or AC.
6. Only -48 V DC PSMs can be used in -48 V DC PSM shelf. Only AC PSMs can be used in AC PSM shelf.

ti-cdma-05993.eps

Figure 1-2 shows a typical low capacity UBS Macro BTS expandable frame. This frame is expandable to mid-capacity configuration. Expansion to high-capacity configuration is not currently available.

Figure 1-2 Low capacity UBS Macro BTS starter frame (1800 mm rack)

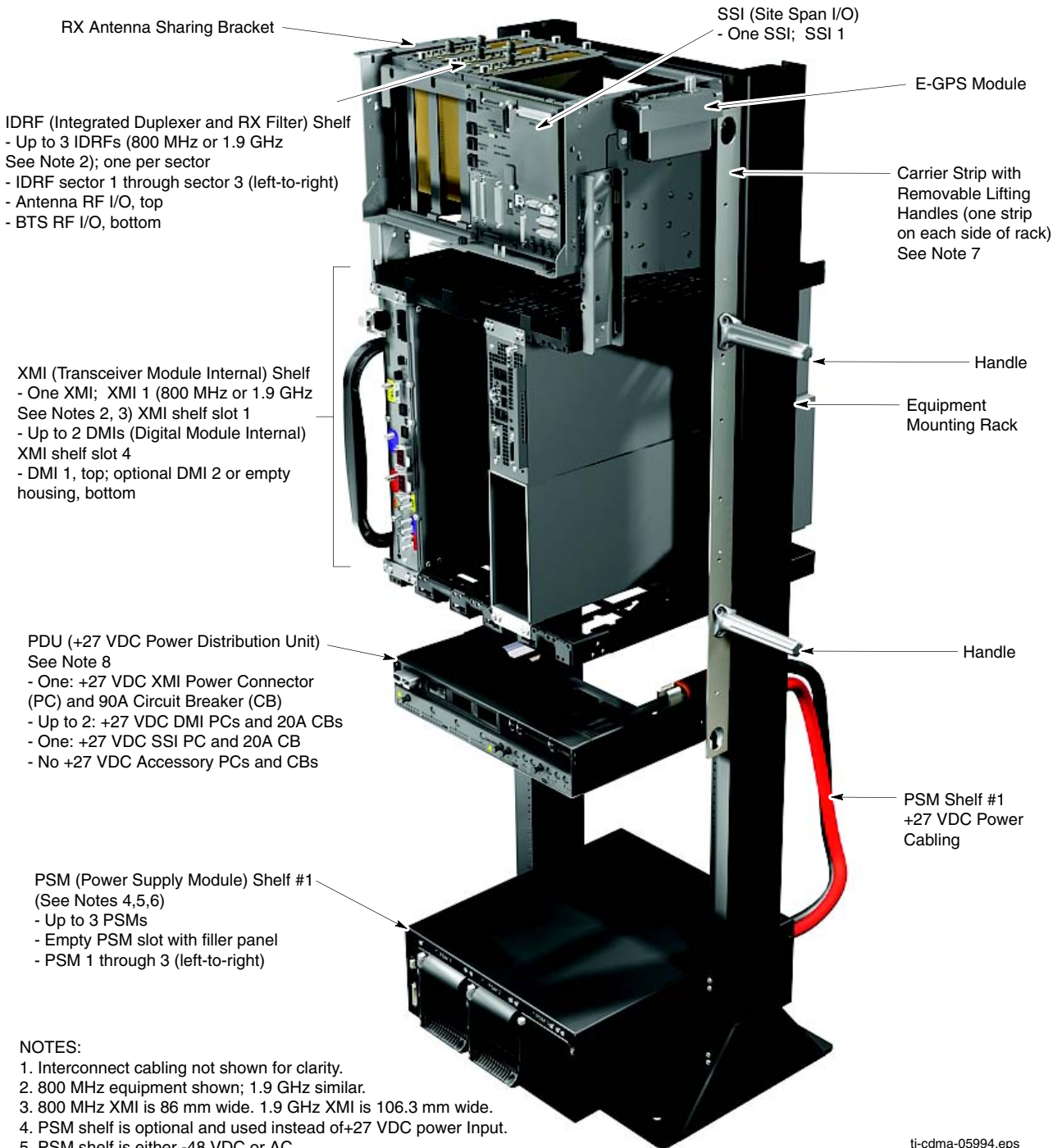

NOTES:

1. Interconnect cabling not shown for clarity.
2. 800 MHz equipment shown; 1.9 GHz similar.
3. 800 MHz XMI is 86 mm wide. 1.9 GHz XMI is 106.3 mm wide.
4. PSM shelf is optional and used instead of +27 VDC power input.
5. PSM shelf is either -48 VDC or AC.
6. Only -48 VDC PSMs can be used in -48 VDC PSM shelf. Only AC PSMs can be used in AC PSM shelf.
7. Carrier strips are removable.
8. PDU may be moved down 6 rack units to ease future expansion.

ti-cdma-05994.eps

Figure 1-3 shows a UBS Macro BTS mid-capacity frame. The mid-capacity configuration is an expansion of the low-capacity configuration. This frame is expandable to high-capacity configuration, but the high-capacity configuration is not currently available.

Figure 1-3 UBS Macro BTS mid-capacity frame (1800 mm rack)

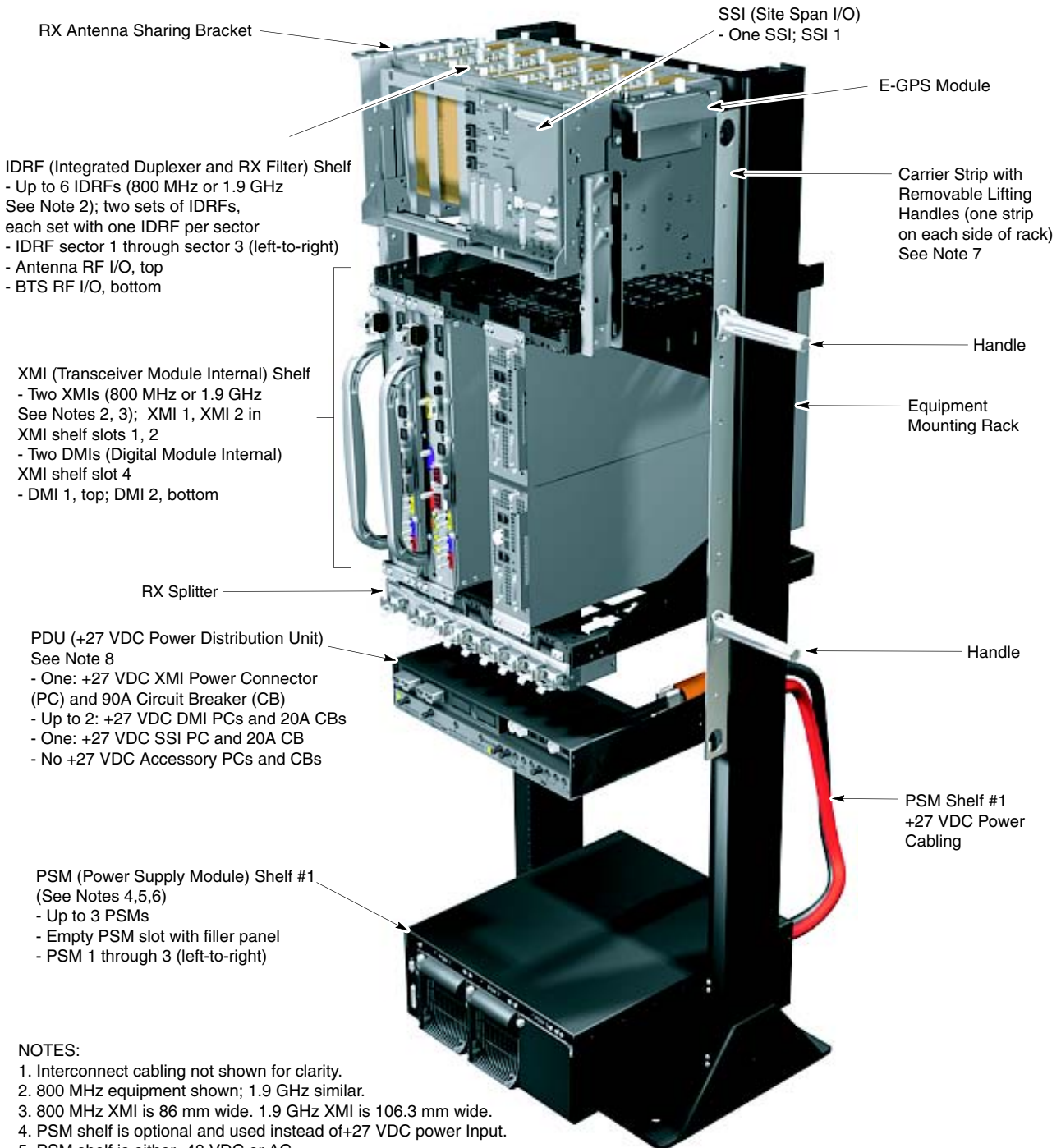

NOTES:

1. Interconnect cabling not shown for clarity.
2. 800 MHz equipment shown; 1.9 GHz similar.
3. 800 MHz XMI is 86 mm wide. 1.9 GHz XMI is 106.3 mm wide.
4. PSM shelf is optional and used instead of +27 VDC power Input.
5. PSM shelf is either -48 VDC or AC.
6. Only -48 VDC PSMs can be used in -48 VDC PSM shelf. Only AC PSMs can be used in AC PSM shelf.
7. Carrier strips are removable.
8. PDU may be moved down 6 rack units to ease future expansion.

ti-cdma-05995.eps

Figure 1-4 shows a typical fully expanded high capacity 800 MHz UBS Macro BTS frame.

Figure 1-4 High capacity 800 MHz UBS Macro BTS fully expanded frame (1800 mm rack)

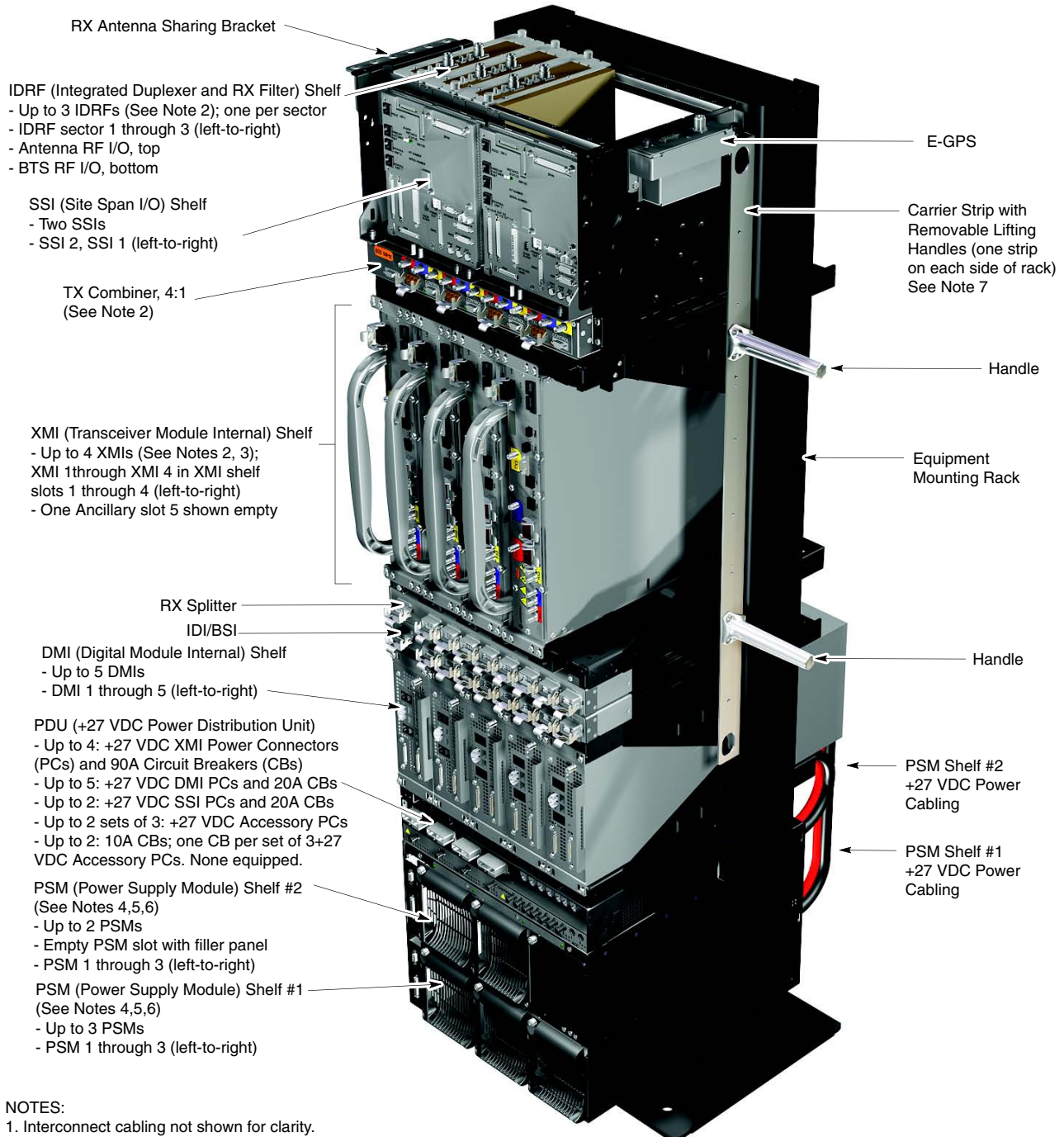

- NOTES:
1. Interconnect cabling not shown for clarity.
 2. 800 MHz equipment shown.
 3. 800 MHz XMI is 86 mm wide.
 4. PSM shelves are optional and used instead of +27 VDC power Input.

5. Both PSM shelves are either -48 VDC or AC.
6. Only -48 VDC PSMs can be used in -48 VDC PSM shelf. Only AC PSMs can be used in AC PSM shelf.
7. Carrier strips are removable

ti-cdma-05996.eps

Figure 1-5 shows a typical fully expanded high-capacity 1.9 GHz UBS Macro BTS frame.

Figure 1-5 High-capacity 1.9 GHz UBS Macro BTS fully expanded frame (1800 mm rack)

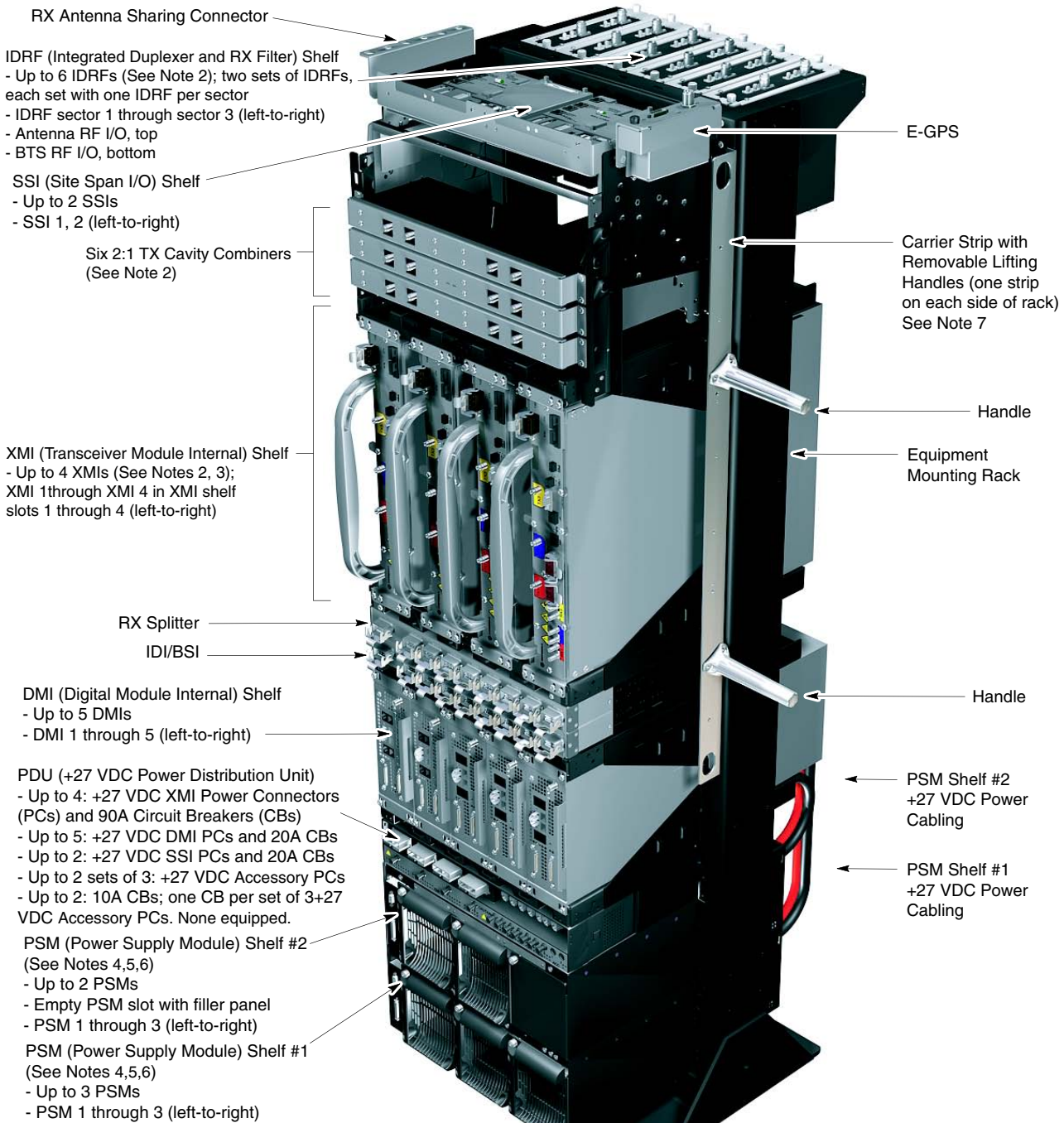

NOTES:

1. Interconnect cabling not shown for clarity.
2. 1.9 GHz equipment shown.
3. 1.9 GHz XMI is 106.3 mm wide.
4. PSM shelves are optional and used instead of +27 VDC power Input.
5. Both PSM shelves are either -48 VDC or AC.
6. Only -48 VDC PSMs can be used in -48 VDC PSM shelf. Only AC PSMs can be used in AC PSM shelf.
7. Carrier strips are removable

ti-cdma-05997.eps

Items to be installed

Figure 1-6 shows the items to be installed.

Figure 1-6 Items to install

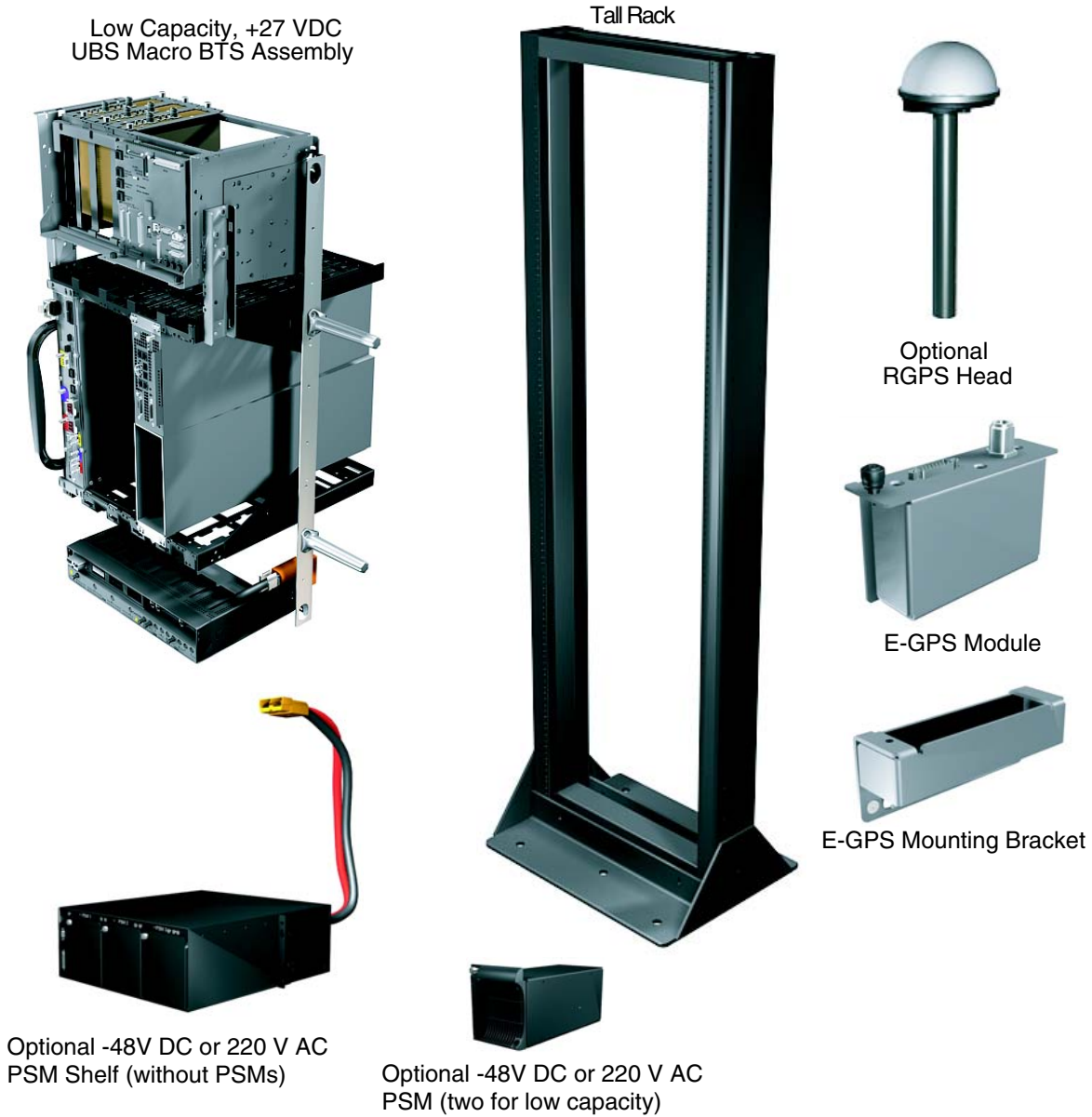

Tools and materials

Required tools and materials

The following tools and materials are required to perform the installation:

- Battery driver, capable of 3.95 N-m to 5.09 N-m (35-45 in-lb) torque
- T20 and T25 TORX bits with 12 inch extension
- Torque drivers; 1 N-m, 2.3 N-m, 4.8 N-m +/- 10%
- 8 mm SMA connector torque wrench; 1.02 N-m (9 in-lb) +/- 10%
- 19 mm N-type connector torque wrench; 4.3 N-m (38 in-lb) +/- 10%
- Phillips screwdriver
- Flat screwdriver
- 3/8-inch ratchet -5.6 N-m (50 in-lb)
- 8-mm socket
- 19-mm socket
- 10-mm deep set socket
- 9/16-inch socket
- 3/16-inch socket
- Side cutters
- Dust mask
- Safety glasses
- Ear plugs
- Marker for marking outline on floor
- Tape measure with millimeter scale, capable measuring up to 1200 mm or with inch scale, capable measuring up to 48 inches
- Shop vacuum
- Cable tie-wraps
- Scissors or knife
- 0.25 W SMA-type terminators for any unused directional port connectors on an IDRF - customer supplied

- 50 W N-type terminators for any unused TX/RX connectors on an IDRFB - customer supplied
- Digital Multi-Meter (DMM) Fluke Model 8062A with Y8134 test lead kit or equivalent; used for precision DC and AC measurements, requiring 4-1/2 digits.
- One DC connector housing per DC power feed (see [Table 2-8](#) for quantity of power feeds)
 - Orange DC connector housing used for +27 V DC application (see [Table 2-14](#) for part information).
 - Blue DC connector housing used for -48 V DC application (see [Table 2-15](#) for part information).
- DC connector cable clamps for power cable (see [Table 2-14](#) or [Table 2-15](#) for part information).
- DC connector housing contacts/lugs for power cable (see [Table 2-14](#) or [Table 2-15](#) for part information).
- Crimper tool - Anderson Power Products part number 1368 - Hydraulic hand tool, maximum cable size of 300 MCM.

Other tools are required to install the rack to the floor. The method of installing the rack to the floor, as specified by a Structural Engineer, determines what additional tools are required.

Recommended tools

The following tools are not required, but they may make the installation easier:

- Long screwdriver extension
- Long socket wrench extension
- Mechanical hoist capable of lifting 100 kg, 2 m high
- Banding cutter

Unpacking Instructions

Unpacking the carrier strip assembly

The UBS Macro BTS carrier strip assembly includes the low-capacity frame equipment pre-mounted and cabled. This assembly consists of the following equipment:

- One set of IDRFs, up to three IDRFs.
- One SSI
- One XMI
- One DMI
- PDU with one +27 V DC input power feed and circuit breaker/output power connector assemblies as follows: XMI 1, DMI 1, DMI 2 and SSI 1.



NOTE

The STGN4034 Installation Kit is also packaged with the UBS Macro carrier strip assembly. The installation kit contains all of the M5 x 12 mm screws needed to rack mount the equipment.

The UBS Macro BTS carrier strip assembly is shipped in a large carton that is banded to a pallet. Follow the steps in [Procedure 1-1](#) to unpack the carrier strip assembly.

Procedure 1-1 Unpacking the carrier strip assembly

1	Cut the bands that hold the carton to the pallet.
2	Lift the carton up and off of the pallet. Remove the cut bands
3	Remove the inner carton support (see Figure 1-7).
	 <h3 style="background-color: #00b050; color: white; padding: 2px;">NOTE</h3> <p>The carrier strip assembly is sitting on a wooden support (see Figure 1-8).</p>
4	Locate the STGN4034 Installation Kit that is packaged with the UBS Macro carrier strip assembly.
5	Inspect the carrier strip assembly for damage.

Figure 1-7 Carrier strip assembly with inner carton support



ti-cdma-06026.eps

Figure 1-8 Carrier strip assembly with inner carton support removed

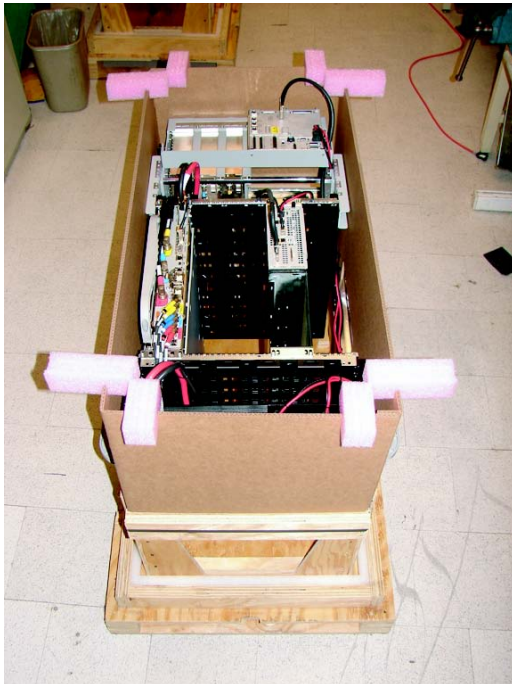
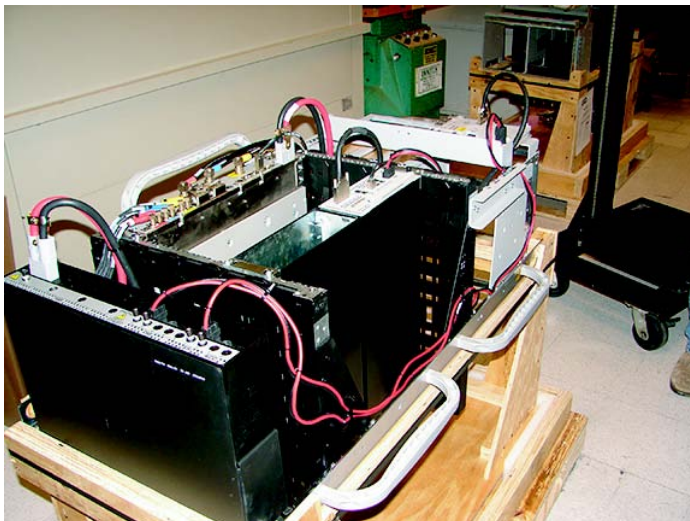

ti-cdma-06027.eps

Unpacking accessory equipment

UBS Macro BTS accessory equipment is shipped in smaller cartons. The quantity of cartons is dependent on the BTS site configuration and options. Follow the steps in [Procedure 1-2](#) to unpack the accessory equipment.

Procedure 1-2 Unpacking accessory equipment

1	Open an accessory equipment carton.
2	Inspect the contents of the carton for damage.
3	Verify that the carton contains all of the equipment stated on the packing list.
4	Repeat this procedure for each carton in the shipment.

UBS Macro BTS Installation Procedure

Overview

Introduction

This chapter provides the information and procedures to install the items and cabling for the UBS Macro BTS. Both pictorial and textual information is presented.

The installation is broken into a set of tasks. Each set of tasks is broken down into a set of steps.

Individual tasks or steps are based on the overall installation sequence and must not be performed randomly.

Structural engineer

A Structural Engineer has to determine the method and equipment needed to mount the rack to the floor.

Required items

For each set of tasks, a list of tools and items is given that covers those specific tasks.

A full list of tools is given in [Tools and materials on page 1-16](#).

Cabling and configuration options

All of the configurations require unique cables and/or items. Installation of all cables and all items is covered. When applicable, the cabling and configuration options are called out. Not all cables or items covered in this manual should be installed. Consult the site plan to determine exactly what items to install.

Color coding

Many of the connectors and cables are color coded. As the cables are installed, the cable color code should match the color code of the connector. Not all cables and connectors are color coded.

Some, but not all, of the color coding is called out in the installation procedures. The scheme of the color codes is shown in [Table 2-1](#) and [Table 2-2](#).

Table 2-1 Color code – DC power connectors/cables

Color	Represents
ORANGE	+27 V DC Power
BLUE	-48 V DC Power

Table 2-2 Color code - RF Equipment and Connectors/Cables

Color	Represents
ORANGE	800 MHz RF equipment
BLUE	1.9 GHz RF equipment
GREEN	2.1 GHz RF equipment
RED	Sector 1
BLUE	Sector 2
YELLOW	Sector 3
GREY	RFL (reflected) Main
BROWN	RFL DIV (reflected diversity)
WHITE	For RF use, it can mean: <ul style="list-style-type: none"> • Main • FWD (forward main)
BLACK	For RF use, it can mean: <ul style="list-style-type: none"> • Diversity • FWD DIV (forward diversity)

Cable list, diagrams and connectors

Overview

This section gives a UBS Macro BTS external input/output (I/O) cable run list – a list of cables and the end connection points. This can be used as a check-off sheet during installation. For any item that cables connect to, that item and the associated connectors are shown.

UBS Macro BTS external I/O cable run list

Table 2-3 gives the UBS Macro BTS external input/output cable run list. Not all cables are needed for all configurations.



NOTE

Each row in Table 2-3 is a separate unique cable run even if the reference designator and the part number are duplicated.

Table 2-3 UBS Macro BTS external I/O cable run list

Reference (used in manual)	Part number	Item	From Connector	To Item	Connector	Notes
DD	Customer	Rack	Double-studs	Site Master Ground Bar (MGB)	Customer	Earth Ground Cable/Wire (4 AWG or larger diameter)
NN	One of: 3086039H10 through H14 (Note 1)	RGPS Head	12-pin Circular (Deutsch)	RGPS Lightning Arrester	RGPS Lightning Arrester	RGPS Head Cable, shielded twisted pair
AA	3086433H14	SSI	RGPS (15-pin D)	RGPS Lightning Arrester	RGPS Lightning Arrester	RGPS Head Cable, shielded twisted pair
W	CGDS19797321	SSI	SPANS (37-pin D)	Customer	Equipment	T1/E1 Bal., shielded twisted pair cable (Note 2)

Continued

Table 2-3 UBS Macro BTS external I/O cable run list (Continued)

Reference (used in manual)	Part number	From		To		Notes
		Item	Connector	Item	Connector	
None	Customer	SSI (E1 Daughter Card)	SPAN RX/TX # (BNCs)	Customer	Equipment	E1 Unbal. 75-Ohm Coax Up to 8 cables (Note 2)
X	CGDS19797321	SSI	CUSTOMER IP 1-12 OP 1-4 (37-pin D)	Customer	Equipment	Customer Input/Output (IP/OP)
X	CGDS19797321	SSI	CUSTOMER IP 13-24 OP 5-8 (37-pin D)	Customer	Equipment	Customer Input/Output (IP/OP)
DC	Customer	PDU +27 V DC Power Input Cable	Orange (2-contact, Anderson SB-350)	DC Power Wires; Red & Black	Orange (2-contact, Anderson SB-350)	+27 V DC Power From Customer Source
CC	Customer	-48 V DC PSM Shelf Power Input Cable	Blue (2-contact, Anderson SB-350)	DC Power Wires; Blue & Black	Blue (2-contact, Anderson SB-350)	-48 V DC Power From Customer Source
AC	Customer	AC PSM Shelf	AC Input Terminal Block	Customer	Equipment	AC Power From Customer Source
None	Customer	Sector 1 IDRF	TX/RX MAIN (N-type, coaxial)	Sector 1 TX/RX Main Ant. Cable	N-type, coaxial	RF Ant., 50-Ohm Coaxial (Note 3)
None	Customer	Sector 2 IDRF	TX/RX MAIN (N-type, coaxial)	Sector 2 TX/RX Main Ant. Cable	N-type, coaxial	RF Ant., 50-Ohm Coaxial (Note 3)
None	Customer	Sector 3 IDRF	TX/RX MAIN (N-type, coaxial)	Sector 3 TX/RX Main Ant. Cable	N-type, coaxial	RF Ant., 50-Ohm Coaxial (Note 2)
None	Customer	Sector 1 IDRF	RX DIV (N-type, coaxial)	Sector 1 RX Div. Ant. Cable	N-type, coaxial	RF Ant., 50-Ohm Coaxial (Note 2)

Continued

Table 2-3 UBS Macro BTS external I/O cable run list (Continued)

Reference (used in manual)	Part number	From		To		Notes
		Item	Connector	Item	Connector	
None	Customer	Sector 2 IDRF	RX DIV (N-type, coaxial)	Sector 2 RX Div. Ant. Cable	N-type, coaxial	RF Ant., 50-Ohm Coaxial (Note 2)
None	Customer	Sector 3 IDRF	RX DIV (N-type, coaxial)	Sector 3 RX Div. Ant. Cable	N-type, coaxial	RF Ant., 50-Ohm Coaxial (Note 2)



NOTE

1. Cables 3086039H10 through H14 are various lengths; where the part number suffix indicates the following cable lengths: H10 = 15 m (50 ft), H11 = 38 m (125 ft), H12 = 76 m (250 ft), H13 = 152 m (500 ft) and H14 = 304 m (1000 ft). Cables H10 and H11 are included in Motorola option T472AG and T472AH, respectively. Cables H12, H13 and H14 are included in Motorola option T472AJ, T472AK and T472AL respectively.
2. Cable may be connected to a lightning arrester.

Connector locations

Figure 2-1 through Figure 2-4 show the items that external cables connect to. For each connector, the name is stated and where the associated cable goes.

IDRF I/O details

Figure 2-1 shows connector locations and usage for the 800 MHz IDRF.

Figure 2-2 shows connector locations and usage for the 1.9 GHz IDRF.

Figure 2-1 800 MHz IDRf I/O connectors

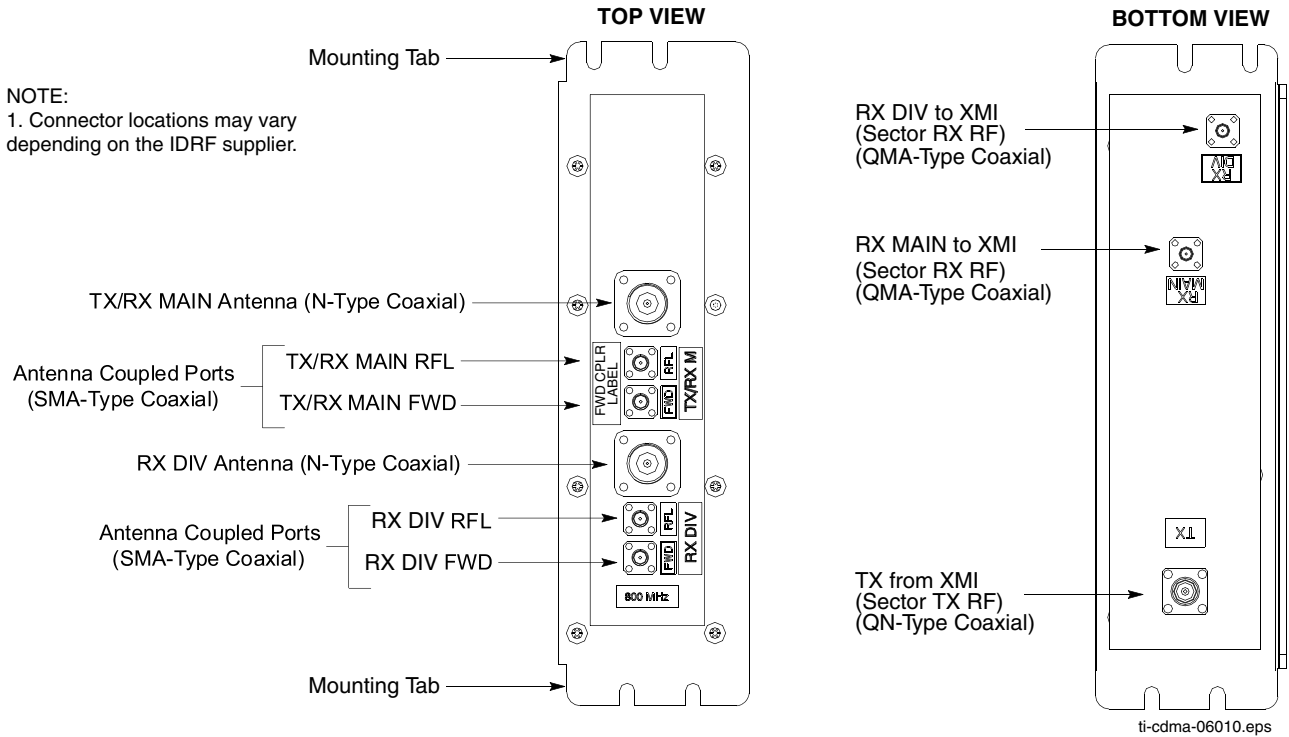
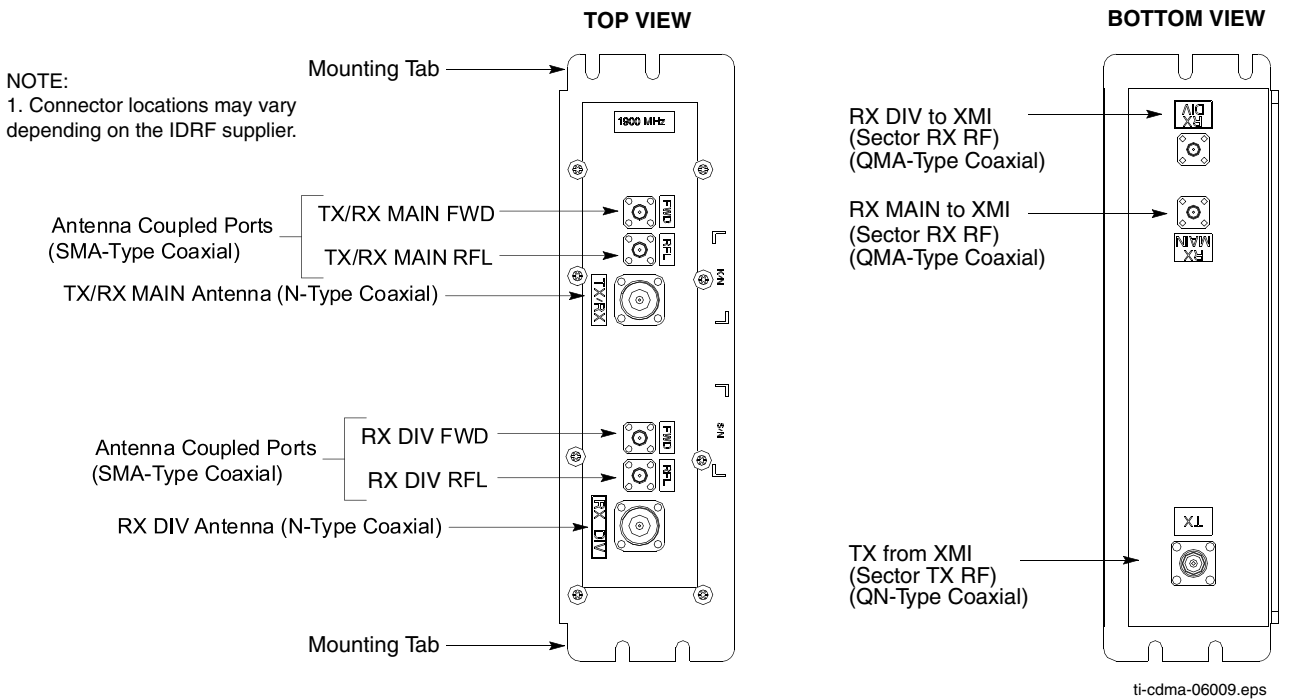

Figure 2-2 1.9 GHz IDRf I/O connectors



SSI I/O details

[Figure 2-3](#) shows connector locations and usage for the SSI and the optional E1 unbalanced daughter card.

Figure 2-3 SSI front panel connectors

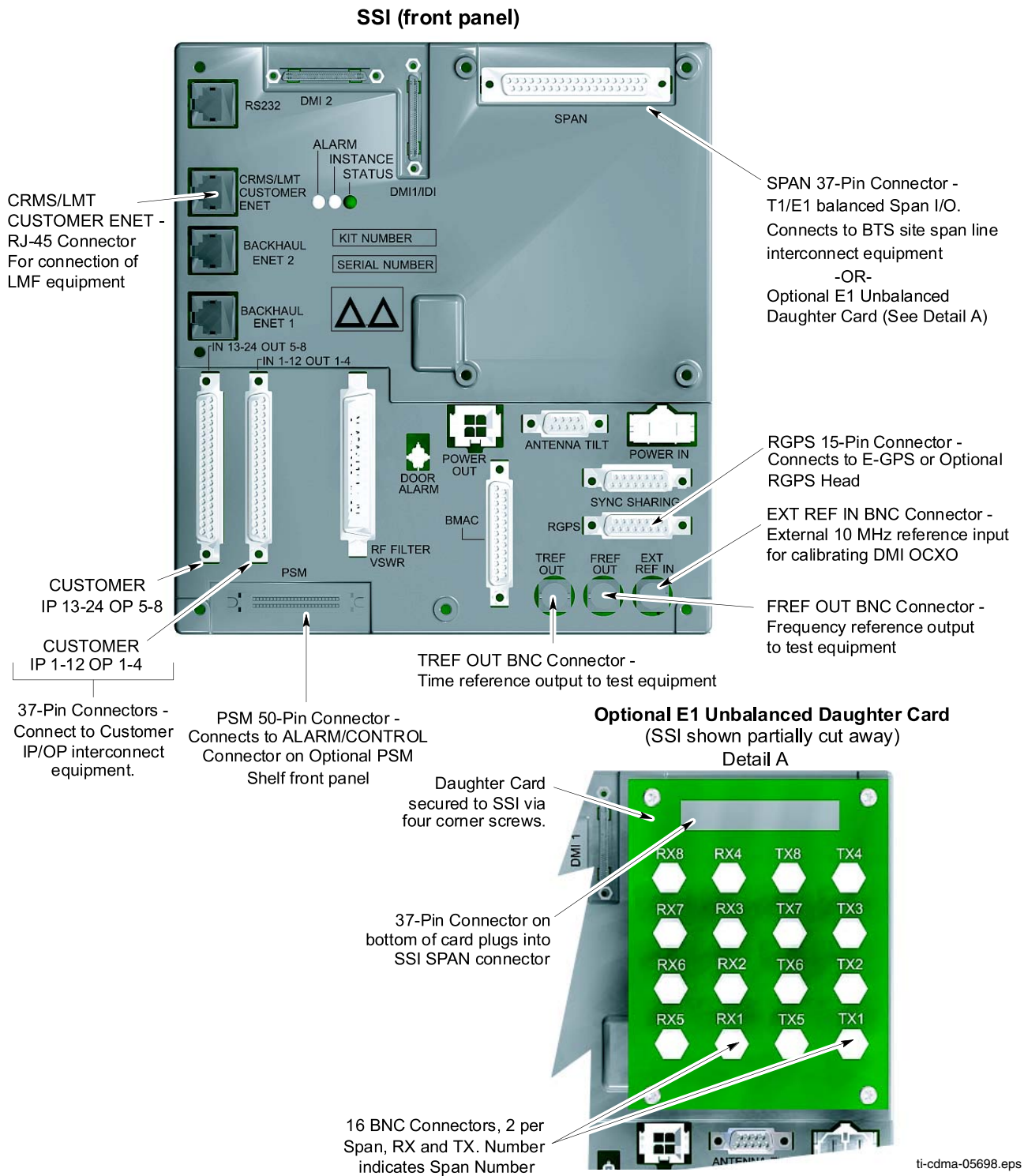

PSM shelf front panel I/O details

Figure 2-4 shows the front panel connector locations and usage for the optional PSM shelf.

Figure 2-4 PSM shelf front panel connectors

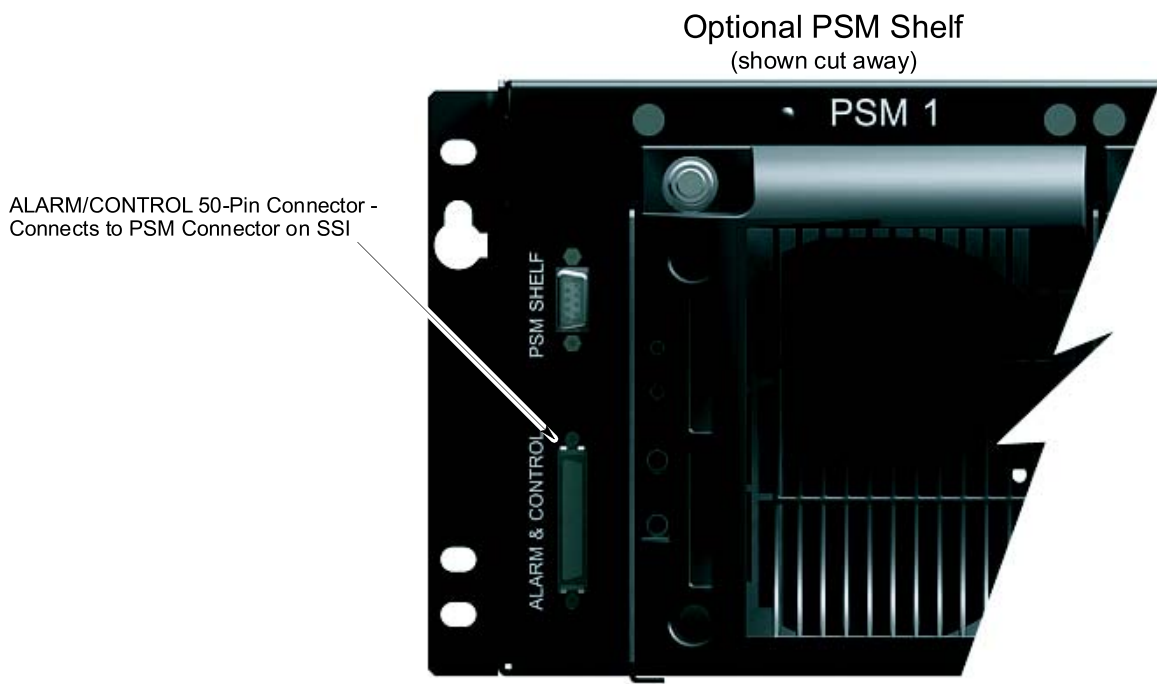

ti-cdma-05699.eps

Full installation sequence

Overview

The installation of the UBS Macro BTS is composed of two parts to be performed in this order:

1. Verifying site and equipment
2. Physical installation

Once the site is verified, the BTS can be physically installed.

Details to perform each part are given here along with any prerequisites.

Prerequisites

This document is not a planning guide and is not meant to provide planning information. All site planning, including power requirements and installation of site power, must be completed before performing the installation. The site verification will help verify this prerequisite has been met.

A Structural Engineer has been consulted and has determined the method to mount the rack to the floor.

Verifying site and equipment

This can be performed at any time prior to the physical installation. Verifying site and equipment is composed of two portions to be performed in this order:

1. Site verifications - Refer to [Site verification on page 2-15](#) to verify the site.
2. Unpack and identify the equipment - Refer to [Unpacking Instructions on page 1-18](#) and unpack the various cartons. Refer to [Figure 1-6](#) and verify the correct equipment is present. The exact number and type of equipment is site dependent.

Physical installation

Recommendations

Motorola recommends performing the physical installation all at once and not in multiple stages.

Motorola recommends installing cable ties to eliminate confusion and clutter.

Color code

Follow the color codes for the cables and connectors when applicable. Refer to [Overview on page 2-2](#) of this chapter for a detailed description of the color codes.

Default values

Unless otherwise specified, use these default values during the installation.

- All screws are M5 x 12 mm and require a T25 TORX bit. These screws are included in the STGN4034 Installation Kit that is packaged with the UBS Macro carrier strip assembly.
- Torque values are to be within +/-10% of value shown.
- Tighten screws and bolts to 4.77 N-m (42 in-lb).
- Maximum torque for the IDRf screws is 2.37 N-m (21 in-lb).
- Tighten SMA connectors to 1.02 N-m (9 in-lb).
- Tighten N-connectors on cables to 4.3 N-m (38 in-lb).

Preview of installation tasks

This section provides a preview of all of the tasks to be performed to install the UBS Macro BTS as well the sequence of those tasks. Each specific task is detailed in its own section later in this manual.



NOTE

Each item number below corresponds to a specific task number. The task number is used to identify the task and its occurrence within the overall installation sequence.

** indicates an optional task. The system configuration determines if the optional task is to be performed or if it can be skipped.

Perform the following tasks in the order shown when installing the UBS Macro BTS.

1. ** Install the optional RGPS head and route cable (NN) to the BTS site. Skip this task if the optional RGPS head is not required.
2. Mount rack to floor using the hardware, tools, and procedures defined by your Structural Engineer. Motorola recommends using 6 carbon steel grade 8.8 M12 bolts.
3. Install earth ground wire/cable (DD) between the site Master Ground Bar (MGB) and equipment rack. Attach ground wire to the top of equipment rack using 2 studs/nuts and a 10 mm socket and ratchet. Tighten to 5.65 N-m (50 in-lb).
4. ** Perform this task for -48 V DC or 220 V AC UBS only. Install the PSM shelf to the bottom of the rack using 6 screws; three screws on each left and right side. Install the appropriate, -48 V DC or 220 V AC, PSMs into PSM shelf slots 1 and 2.

- 5.** Mount the UBS Macro BTS carrier strip assembly to the rack at the predetermined height. First, measure and install 2 hanger screws in the rack rails; one screw on each left and right side at the proper height. Second, four people lift the UBS Macro BTS carrier strip assembly via the carrier strip handles and hang the assembly on the 2 hanger screws in the rack rails. Install 2 screws in the keyholes at the bottom of each carrier strip. Third, completely fasten the UBS assembly/carrier strips using 22 more screws; 11 screws on each left and right side. Completely tighten these 22 screws. Then completely tighten the 4 screws in the keyholes.
- 6.** ** Install the additional equipment required to expand the UBS Macro BTS low-capacity starter/expansion frame to the mid-capacity frame configuration. If the initial UBS Macro BTS installation is for a low-capacity frame configuration, skip this task and go to Task 7. Perform this task only if the initial UBS Macro BTS installation is for a mid-capacity frame configuration.
- 7.** ** For -48 V DC or 220 V AC UBS only, connect the +27 V DC power output cable from the rear of the PSM shelf to the +27 V DC power input cable on the rear of the PDU. Connect the 50-conductor cable (supplied with PSM shelf) between the PSM shelf front panel ALARM/CONTROL connector and SSI PSM connector.
- 8.** Route the customer supplied TX/RX main and RX diversity antenna cables to the front of the Integrated Duplexer RX Filters (IDRFs) at the top of the frame. Connect each antenna cable to the corresponding IDRF connector.
- 9.** Connect customer supplied 0.25 W, 50-Ohm, SMA-type terminators to unused directional coupler port connectors on the front of the IDRFs.
- 10.** ** Install optional RGPS cable (AA). Connect the 15-pin D-connector to the RGPS connector on the front of the SSI. Route the loose end of the cable to the RGPS lightning arrester and connect the wires there. Skip this task if the optional RGPS head is not required.
- 11.** ** Install T1/E1 balanced span I/O cable (W). Connect the 37-pin D-connector to the SPAN connector on the front of the SSI. Route the loose end of the cable to the site span line interconnect equipment and connect the wires.
- 12.** ** Install E1 unbalanced span I/O coaxial cables (customer supplied). Route 75-Ohm coaxial cables, with BNC connectors, from the site span line interconnect equipment to the SSI. Connect each cable to the corresponding BNC connector on the SSI E1 daughter card.
- 13.** ** Install Customer Alarm Input/Output (IP/OP) cables (X). Connect the 37-pin D-connector to the corresponding CUSTOMER IP 1-12 OP 1-4 connector and CUSTOMER IP 13-24 OP 5-8 connector on the front of the SSI. Route the loose end of the cables to the customer IP/OP interconnect equipment and connect the wires.
- 14.** ** Ensure that all circuit breakers are open on the PDU. For +27 V DC UBS only: attach an Orange 2-contact DC connector to Red and Black wires. Connect this Orange connector to the +27 V DC input power cable on the rear of the PDU. Route the loose ends of the wires to the site +27 V DC source and connect the wires.
- 15.** ** Ensure that all circuit breakers are open on the PDU. For -48 V DC UBS only: attach a Blue 2-contact DC connector to Blue and Black wires. Connect this Blue connector to the Blue DC INPUT connector on the rear of the -48 V DC PSM shelf. Route the loose ends of the wires to the site -48 V DC source and connect the wires.
- 16.** ** Ensure that all circuit breakers are open on the PDU. For 220 V AC UBS only: attach customer supplied wiring and conduit for 220 V AC lines. Connect wires and required insertion bridges to the AC INPUT terminal block on the rear of the AC PSM shelf. Route the loose ends of the wires to the site 220 V AC source and connect the wires.

After performing all of the necessary tasks, complete the installation by performing the following:

- Clean up the site.
- Fill out installation check off sheet.

Site verification

Site installation checks

Verify that the site is ready for BTS installation before performing the physical installation.

A detailed layout of the site is provided with the site-specific documentation. Before installing the hardware, compare the information presented here to the site-specific documentation layout and verify with the Site Manager for the following:

- All cable trays are installed.
- All external signal cables are connected.
- Site is clean.
- Site specific documentation covering all site dependent installation information is available.
- The installation area has restricted access. Equipment is meant to be installed and operated in a restricted access location. In order to maintain UL listing, equipment must be installed in a restricted access area.
- The site can maintain the required temperature range.
- The layout meets the minimum clearance requirements for the equipment as listed in [Table 2-5](#), [Table 2-6](#) and [Table 2-7](#).
- All building DC power cables are connected.
- The building meets the voltage and power requirements shown in *Site description (as built)* documents.
- Power cables are present that meet the requirements shown in [Table 2-8](#).
- The procedure, tools, and equipment required to mount the rack to the floor are specified by a Structural Engineer.
- The site can meet the footprint dimensions (as shown in [Figure 2-5](#)) and not violate any of the required clearances.
- Site grounding is according to Grounding Guidelines for Cellular Radio Installations (Motorola part number 68P81150E62).
- The screen (outer shield) of the RF antenna coaxial cable must be connected to earth (grounded) at the entrance to the building. This should be done in accordance with applicable national electrical installation codes (Section 820.93 of the National Electrical Code, ANSI/NFPA 70).
- Verify that the Master Ground Bar is connected to a solid earth ground. This is required to ensure protection from hazardous voltages by providing a high integrity protective earthing circuit when the frame is later grounded to the Master Ground Bar.

- The frames can be mounted as specified in the site-specific documentation.
- Each frame has its own main power cut off.



NOTE

Motorola recommends a separate main power cut off for each frame of the system.

Temperature range

The site building must be able to maintain a temperature between 0° C and 50° C. The life span of electronic equipment is shortened by environmental variations, even though it is designed to operate at extreme temperatures.

Frame physical dimensions

The following table gives the frame dimensions.

Table 2-4 Frame dimensions

Height	Width	Depth	Maximum Weight
1800 mm (70.86 inches)	575 mm (22.63 inches)	700 mm (27.55 inches)	312 kg (688 lbs)

Frame clearances

The following tables give the frame clearances for various configurations.

Table 2-5 Minimum frame clearances for airflow

Front	Rear	Top	Left side	Right side	Bottom
150 mm (5.9 inches)	150 mm (5.9 inches)	300 mm (11.8 inches)	0 mm (0 inches)	0 mm (0 inches)	0 mm (0 inches)

Table 2-6 Minimum frame clearances for maintenance - front access only

Front	Rear	Top	Left side	Right side	Bottom
700 mm (27.55 inches)	150 mm (5.9 inches)	300 mm (11.8 inches)	75 mm (2.95 inches)	75 mm (2.95 inches)	0 mm (0 inches)

Table 2-7 Minimum frame clearances for maintenance - front and rear access

Front	Rear	Top	Left side	Right side	Bottom
700 mm (27.55 inches)	150 mm (5.9 inches)	300 mm (11.8 inches)	0 mm (0 inches)	0 mm (0 inches)	0 mm (0 inches)

Frame DC input power and power cabling information

Table 2-8 gives DC input power cabling and circuit breaker information.



NOTE

For frame maximum and typical power consumption, refer to the *UBS (800 MHz) BTS Specification (B1)* document or *UBS (1.9 GHz) BTS Specification (B1)* document whichever is applicable.

Table 2-8 +27 V DC and -48 V DC Frame Power Cabling and Power Supply Breaker Information

Qty of XMIs	Maximum cable length	Cable size (AWG)	Cable insulation temperature rating (° C)	Qty of power feeds (+ and - pairs)	Breaker size per feed (Amps DC)
1	661.11 cm (21.69 ft)	2/0	200	1	250
1	833.63 cm (27.35 ft)	3/0	150	1	250
1	1051.25 cm (34.499 ft)	4/0	150	1	250
2	661.11 cm (21.69 ft)	2/0	200	1	250
2	833.63 cm (27.35 ft)	3/0	150	1	250
2	1051.25 cm (34.499 ft)	4/0	150	1	250
3	661.11 cm (21.69 ft)	2/0	200	2	250
3	833.63 cm (27.35 ft)	3/0	150	2	250
3	1051.25 cm (34.499 ft)	4/0	150	2	250

Continued

Table 2-8 +27 V DC and -48 V DC Frame Power Cabling and Power Supply Breaker Information (Continued)

Qty of XMIs	Maximum cable length	Cable size (AWG)	Cable insulation temperature rating (° C)	Qty of power feeds (+ and - pairs)	Breaker size per feed (Amps DC)
4	661.11 cm (21.69 ft)	2/0	200	2	250
4	833.63 cm (27.35 ft)	3/0	150	2	250
4	1051.25 cm (34.499 ft)	4/0	150	2	250

Frame positioning

Typically, equipment frames are positioned side-by-side, with the frame fronts facing the same direction.

Rack base description and dimensions

The base of the rack consists of the following:

- Isolation pads attached to the base to isolate the rack from the floor. The isolation pads are positioned between the floor and the base.
- Six 22 mm (0.87 inches) M12 mounting holes.
- Plastic shoulder washer in each hole to isolate the frame from the floor. [Figure 2-5](#) shows the footprint of the rack.

Figure 2-5 Rack footprint

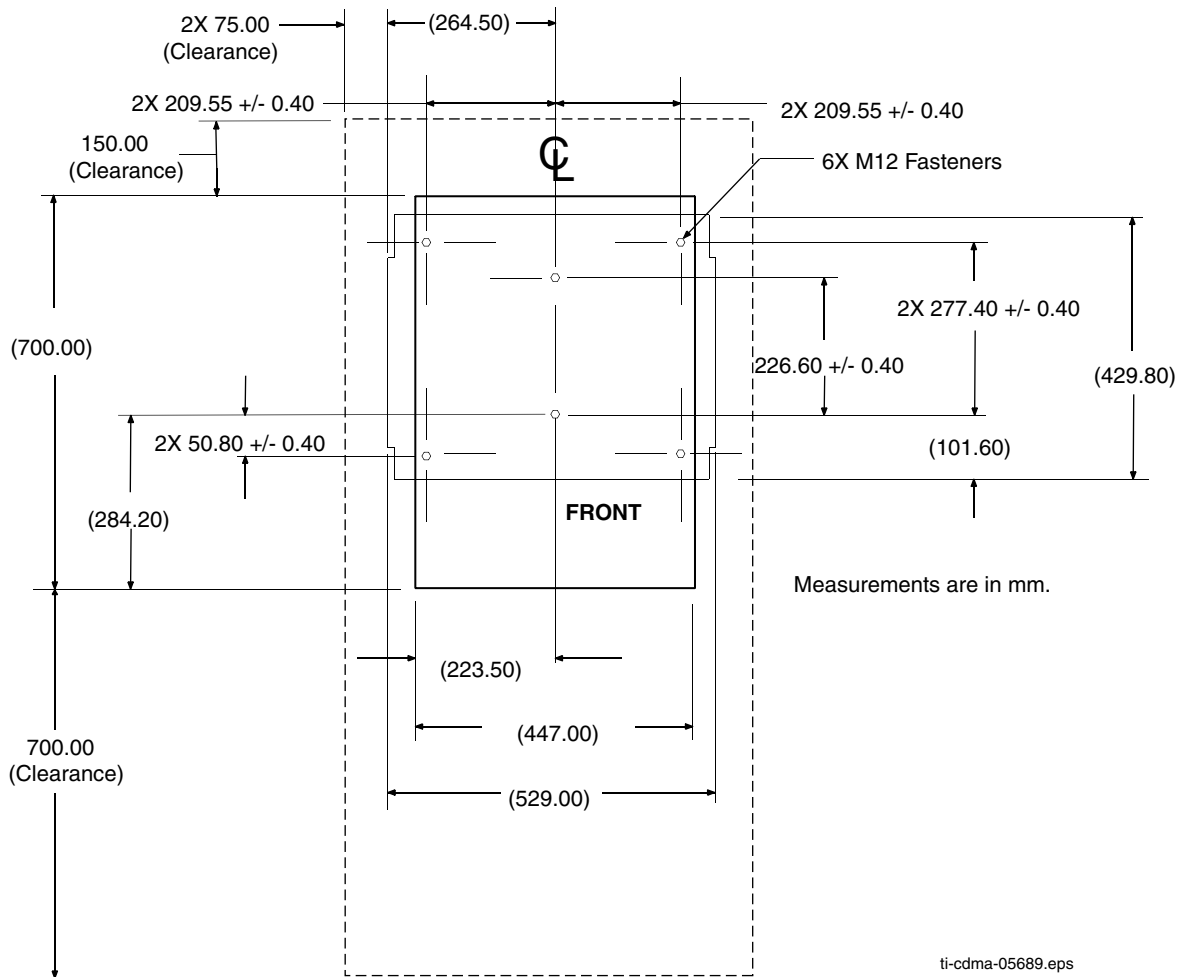

Task 1: Installing RGPS Head

Objective

The objective of this procedure is to install the optional Remote GPS (RGPS) head and cables (NN and AA). The site configuration/characteristics determines whether an RGPS head and cables are to be installed.

Any of the following RGPS heads may be used:

- STLN6594 (Motorola part number)
- 0186012H04 (Motorola part number)



NOTE

Cable NN works with any of the above listed RGPS heads.

RGPS head installation

Required items

The following tools are required:

- Adjustable torque ratchet with metric socket set
- Flat head screwdriver
- Lightning Arrestor (Motorola part number CGDSO971017AA1 or equivalent)

Table 2-9 gives a list of the cables for connecting the RGPS head.

Table 2-9 List of required cables for RGPS head installation

Cable	Quantity	Part Number	Description
AA	One	SGKN4430	15 pin D-connector on one end and loose wires (3086433H14) on the other end.
NN	Only one of the following:	3086039H10	RGPS cable, 15 m (50 ft); part of Option T472AG
		3086039H11	RGPS cable, 38 m (125 ft); part of Option T472AH
		3086039H12	RGPS cable, 76 m (250 ft); part of Option T472AJ
		3086039H13	RGPS cable, 152 m (500 ft); part of Option T472AK
		3086039H14	RGPS cable, 304 m (1000 ft); part of Option T472AL

Cabling diagrams

The following figures show the cabling for an RGPS head.

Figure 2-6 RGPS cabling diagram

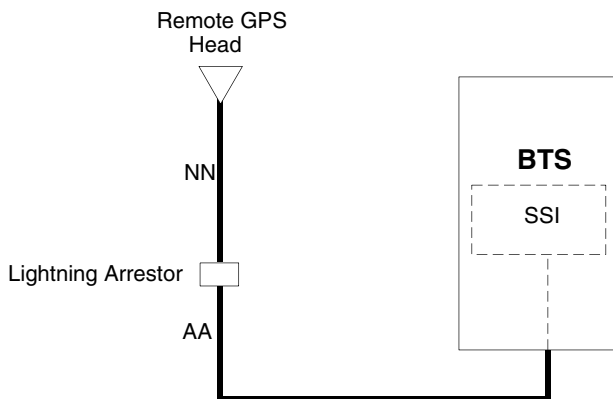

ti-cdma-05700.eps



CAUTION

When wiring the Motorola P/N STLN6594 RGPS Head at a new BTS site, the Yellow and Yellow/Black wires on both sides of the lightning arrestor must be disconnected (see [Figure 2-7](#) and [Figure 2-8](#)). Otherwise, the STLN6594 RGPS Head will be permanently damaged.



CAUTION

If a Motorola P/N 0186012H04 or 0186012H03 RGPS Head at an existing BTS site is being replaced with the Motorola P/N STLN6594 RGPS Head, the Yellow and Yellow/Black wires on both sides of the lightning arrestor must be disconnected (see [Figure 2-7](#) and [Figure 2-8](#)). Otherwise, the STLN6594 RGPS Head will be permanently damaged.



NOTE

The Motorola P/N 0186012H04 RGPS Head will work with the Yellow and Yellow/black wires disconnected or connected on both sides of the lightning arrestor.

Figure 2-7 RGPS wiring

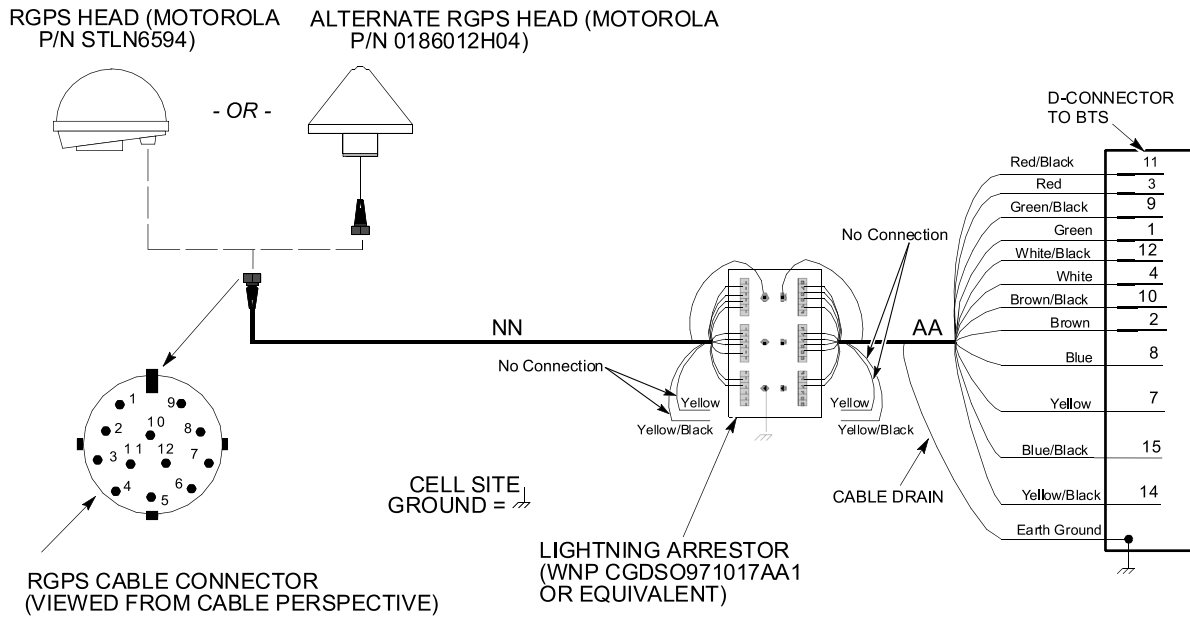

ti-cdma-05701.eps

Figure 2-8 RGPS lightning arrester wiring

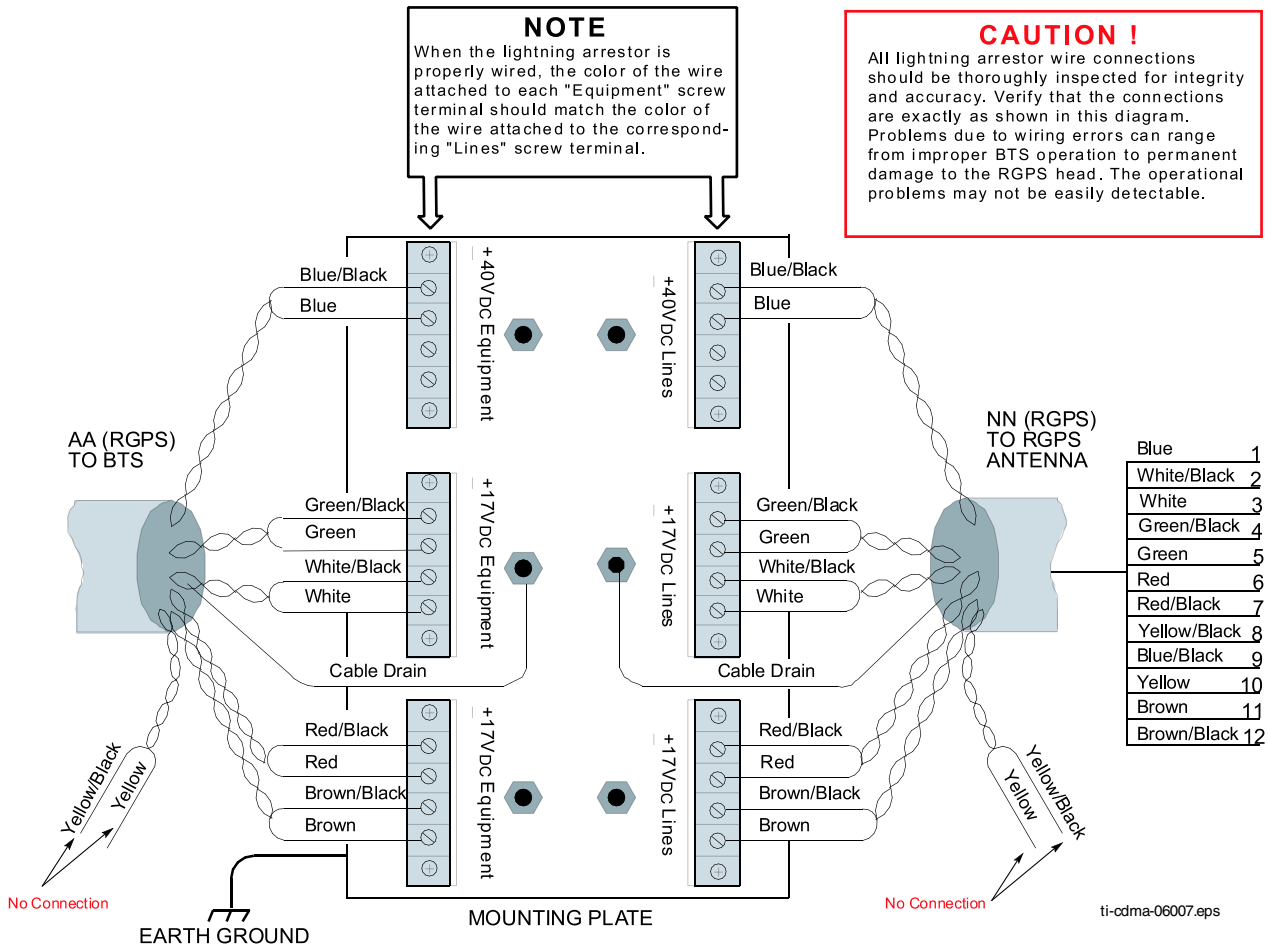

Mounting diagrams

Figure 2-9 and Figure 2-10 show the mounting details for the RGPS heads.

Figure 2-9 RGPS heads

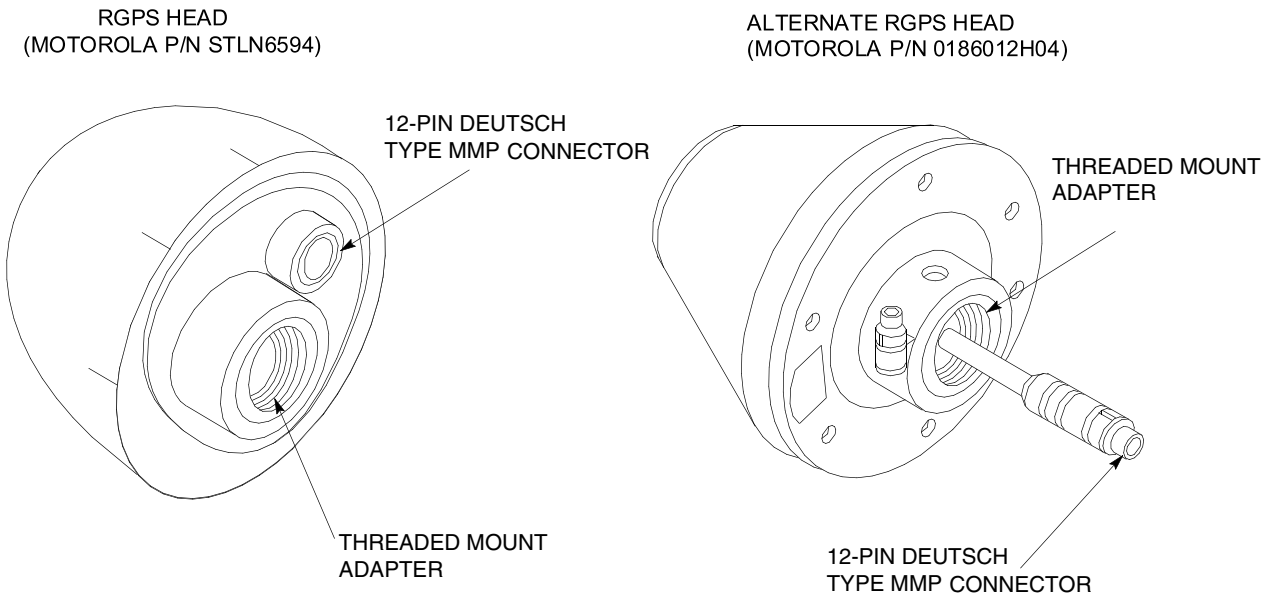

ti-cdma-05702.eps

Figure 2-10 Installing the RGPS head

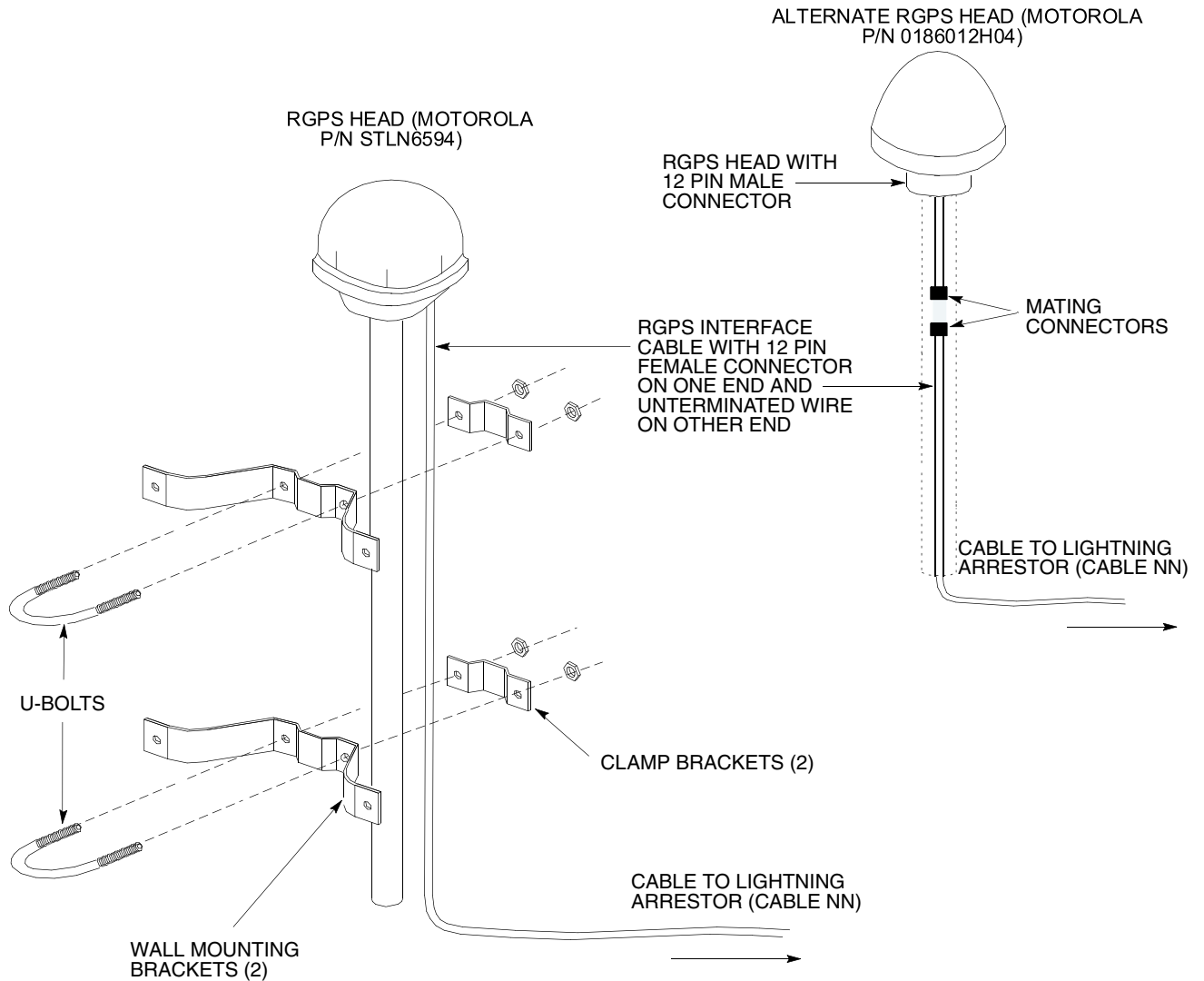

ti-cdma-05740.eps

Cable pinout

Figure 2-11 shows the connector pins on cables AA and NN. Table 2-10 gives the pinout for cable AA and NN and signal names.

Figure 2-11 Connector pin numbering for cables NN and AA

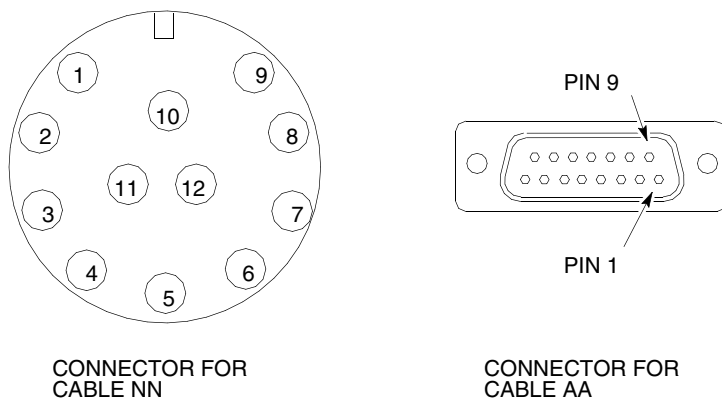

ti-cdma-00047.eps

Table 2-10 Pinout for cables NN and AA



Cable NN (12-cond)			Cable AA (12-cond)	
Pin (12-pins)	Signal	Wire Color	Pin (15-pins)	Signal
9	DC Ground 1	Blue-Black	15	RGPS Return
1	Power 1	Blue	8	RGPS +27 V Supply
8	Not Used	Yellow-Black	14	Not Used
10	Not Used	Yellow	7	Not Used
4	Transmit Port (-)	Green-Black	9	DATA (-) From Head
5	Transmit Port (+)	Green	1	DATA (+) From Head
2	Receive Port (-)	White-Black	12	DATA (-) To Head
3	Receive Port (+)	White	4	DATA (+) To Head
7	Not Connected	Red-Black	11	TDR Ground
6	Not Connected	Red	3	TDR (+)
12	PPS Timing (-)	Brown-Black	10	SYNC (-) From Head
11	PPS Timing (+)	Brown	2	SYNC (+) From Head
		Cable Drain (Shield)	13	Ground
			5, 6	Not Connected

Wire colors are the same for both cables.

Procedure

The procedure to install the RGPS antenna is as follows:

Procedure 2-1 Procedure to install an RGPS head

1	<p>Determine the mounting location for the RGPS head.</p> <div style="display: flex; align-items: center; gap: 10px;">  <div style="border: 1px solid black; background-color: #f4a460; padding: 2px 5px; font-weight: bold; color: white;">WARNING</div> </div> <p>The structure of the wall should be verified by a qualified structural engineer. Mounting the RGPS head and hardware to an inadequate wall structure and/or using inadequate installation methods can result in serious personal injury.</p>
2	Use the appropriate mounting bolts for the mounting surface and install the two wall mounting brackets. Refer to Figure 2-10 .
3	Route the 12-pin Deutsch (that is, circular) connector end of the RGPS cable (cable NN) to the RGPS head.
4	Connect the RGPS cable (cable NN) connector to the RGPS head 12-pin circular connector as shown in Figure 2-7 and Figure 2-10 . Tighten the spinning flange on the connector a quarter turn, to secure the connection.
5	Insert the RGPS mounting pipe into the threaded mount of the RGPS head and carefully tighten it manually.
6	Install the RGPS mounting pipe into the mounting brackets as shown in Figure 2-10 . Tighten the U-bolt clamps to secure the assembly. For the STLN6594 RGPS Head, tape or tie-wrap the cable to the mounting pipe.
7	Route the free end of the BTS RGPS cable (cable NN) to the RGPS cable lightning arrester. Remove any excess cable length and strip off approximately 15 cm of the cable outer insulation.
8	<p>Connect the twelve (12) wires and cable drain of the cable end to the lightning arrester as shown in Figure 2-8. Double check the lightning arrester connections for compliance as displayed in Figure 2-8.</p> <div style="display: flex; align-items: center; gap: 10px;">  <div style="background-color: #00e0e0; padding: 2px 5px; font-weight: bold; color: white;">NOTE</div> </div> <p>RGPS cable AA gets connected to the UBS Macro BTS and then routed to the RGPS cable lightning arrester during Task 8.</p>

Tasks 2-3: Installing Rack & Ground Cable

Objectives

The objectives of this procedure are as follows:

- Mount the rack to the floor.
- Install the ground cable (DD).

Rack requirements

The UBS Macro BTS equipment is designed to be mounted in an open standard 19-inch rack.

To ensure proper equipment support, grounding, and easy installation, Motorola recommends that the UBS Macro BTS equipment be mounted in one of the following applicable Motorola racks:

- STHN4120 19-inch (1800 mm)
- STHN4121 19-inch (1400 mm)
- STHN4122 19-inch (1000 mm)

Structural engineer prerequisite

Ensure that the procedure, tools, and equipment required to mount the rack to the floor are specified by a Structural Engineer.

Required items

The following items are required:

- Rack
- 10 mm socket
- Torque driver
- Flat blade screwdriver
- 6 carbon steel grade 8.8 bolts M12 - customer supplied
- Other items, specified by the Structural Engineer, that are required to install the rack
- Cable DD - customer supplied ground cable, 4 AWG or larger diameter
- Two-hole ground lug and mounting nuts - part of rack hardware kit (CGDSTB54205)

Location of rack earth ground terminals

Figure 2-12 shows the location of the ground terminals on the rack.

Figure 2-12 Location of ground terminals on a Motorola rack

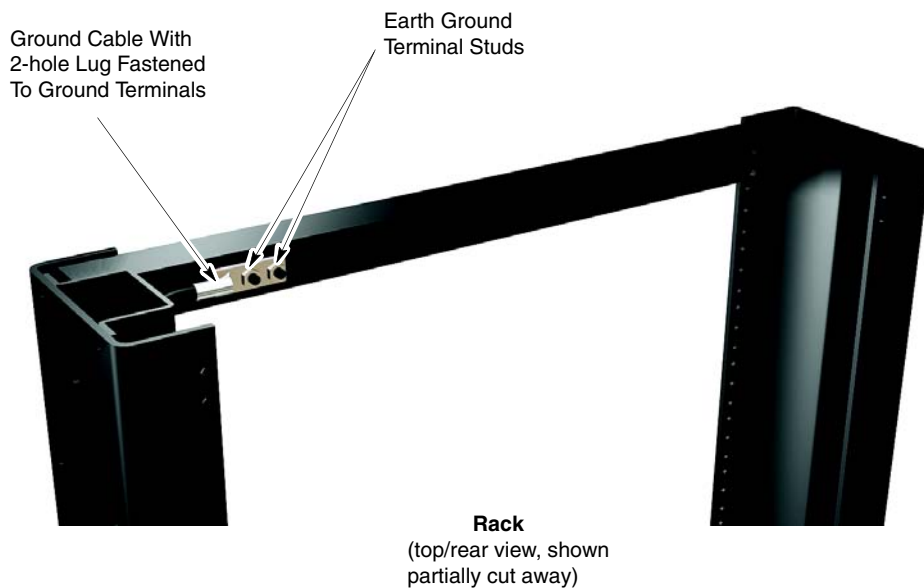

ti-cdma-05691.eps

Procedure

Procedure 2-2 gives the procedure for performing Tasks 2-3.

Procedure 2-2 Performing Tasks 2-3

1	<p>Mount the rack to the floor using the hardware, tools and procedures defined by the Structural Engineer.</p> <div style="display: flex; align-items: center; margin-top: 10px;"> <div style="background-color: #00b050; color: white; padding: 5px 10px; font-weight: bold; text-align: center;">NOTE</div> </div> <p style="margin-top: 10px;">Motorola recommends using carbon steel grade 8.8 M12 bolts.</p>
----------	--

Continued

Procedure 2-2 Performing Tasks 2-3 (Continued)

2	<p>Route the ground cable (cable DD) between the Master Ground Bar (MGB) and the rack.</p> <div data-bbox="483 372 582 478"></div> <div data-bbox="608 395 842 446">NOTE</div> <p>Ground cables must not have sharp bends.</p>
3	Strip insulation from the frame end of cable DD.
4	Attach the 2-hole lug to the rack-end of the cable DD.
5	Attach the end of cable DD with the 2-hole lug to the 2 terminal studs at the top of the rack. Using 2 nuts, 10 mm socket and ratchet, tighten the nuts to 5.65 N-m (50 inch-lb). Refer to Figure 2-12 for location of ground terminal studs on the rack.
6	Cut cable DD to length and connect it to the Master Ground Bar.
7	Verify that the Master Ground Bar is connected to a solid earth ground.

Task 4: Rack Mounting the Optional PSM Shelf

Objectives

The objectives of this procedure are as follows:

- For -48 V DC or 220 V AC UBS only.

Install the PSM shelf to the bottom of the rack. The site configuration/characteristics will determine if a PSM shelf is to be installed.

- Install the appropriate, -48 V DC or 220 V AC, PSMs into PSM shelf slots 1 and 2. For the low capacity frame, either two -48 V DC or two 220 V AC PSMs are installed in the shelf. The second PSM is for redundancy.

Required items

The following items are required:

- Either a -48 V DC or a 220 V AC PSM shelf (whichever is applicable)
- Either two -48 V DC or two 220 V AC PSMs (whichever is applicable)
- Eight (8) M5 x 12 mm screws for mounting the PSM shelf - these screws are packaged with the PSM shelf
- Tape measure with millimeter scale, capable measuring up to 1200 mm or with inch scale, capable measuring up to 48 inches; for measuring screw location heights on rack
- TORX T25 bit and driver
- Torque driver

Procedure

[Procedure 2-3](#) gives the procedure for performing Task 4.

Procedure 2-3 Procedure for Task 4

1	Locate the bottom RU that is to be used for the installation of the PSM shelf.
2	Using a tape measure, measure mounting screw location heights on each side of the rack. Measure from the bottom of the RU determined in step 1 (Refer to Figure 2-13). Mark the following screw locations:

Continued

Procedure 2-3 Procedure for Task 4 (Continued)

	<ul style="list-style-type: none"> • 136 mm (5.35 inches) for PSM shelf
3	Partially insert an M5 x 12 mm screw into each location marked on the rack. Leave the screw heads extending 7 mm out from the rack surface.
4	Remove the PSM shelf from its packaging.
5	Align the keyhole slots in the PSM shelf with the bottom screws, installed in step 3 above (Refer to Figure 2-14).
6	Insert screws in the 6 open slots of the PSM shelf. Using TORX T25 driver, tighten all 8 PSM shelf screws to 4.77 N-m (42 in-lb).
7	<div style="text-align: center;">  <div style="border: 1px solid black; padding: 2px; display: inline-block; background-color: #f4a460;">WARNING</div> </div> <p>PSM weighs approximately 5 kg. Be careful when handling the PSM to prevent damage to the equipment and personal injury.</p> <p>Install the appropriate PSMs into PSM shelf slots 1 and 2 as follows:</p> <ol style="list-style-type: none"> 1. Grasp the handle on the front panel of the PSM with one hand while carefully supporting the bottom of the module with the other hand. 2. Properly orient the PSM and insert it into the slot. 3. Slowly slide the module into the shelf until the rear connectors are fully seated. Make sure that the PSM is fully engaged with the shelf backplane slot connectors.
8	Using a T25 TORX bit and torque driver, tighten the PSM captive retaining thumbscrew to 2.37 N-m (21 in-lb).

Procedural reference diagrams

The following diagrams help clarify certain steps in [Procedure 2-3](#).

Figure 2-13 Hanger screw layout for the optional PSM shelf



NOTE

- 1. All dimensions are in millimeters
- 2. 1800 mm high rack shown. Dimension and hanger screw locations are also applicable for the 1400 mm rack.

ti-cdma-06011.eps

Figure 2-14 Hanging the PSM shelf

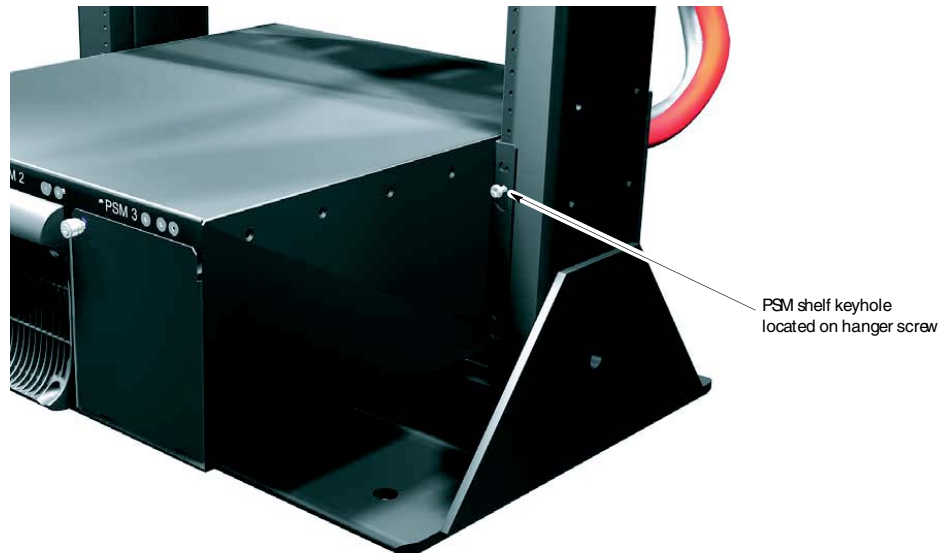

NOTE

- 1. A keyhole/hanger screws located on both the right and left sides. Both keyholes/hanger screws should be engaged at the same time.

ti-cdma-05869.eps

Task 5: Rack Mounting for Low-Capacity Frame

Objective

The objective of Task 5 is to install the UBS Macro carrier strip assembly into an EIA 19-inch rack.

The UBS Macro carrier strip assembly contains all of the equipment required for configuring a low-capacity, +27 V DC starter frame. The layout of the equipment on the carrier strips allows capacity expansion of the frame.

The most common and preferred method is to install the UBS Macro carrier strip assembly into an 1800 mm or 1400 mm high rack. This method requires that there be 600 mm of clearance on the left and right sides of the rack.



NOTE

The UBS Macro carrier strip assembly requires a minimum of 27 Rack Units (RUs) of continuous space.

Required items



The following items are required:

- UBS Macro carrier strip assembly
- Tape measure with millimeter scale, capable measuring up to 1200 mm or with inch scale, capable measuring up to 48 inches; for measuring screw location heights on rack
- Twenty-six (26) M5 x 12 mm screws for mounting the UBS carrier strip assembly - these screws are included in the STGN4034 Installation Kit that is packaged with the UBS Macro carrier strip assembly
- TORX T25 bit and driver
- Torque driver
- 10 mm socket and ratchet

Procedure

Procedure 2-4 gives the procedure for performing Task 5.

Procedure 2-4 Rack Mounting the Low-Capacity, +27 V DC UBS Macro BTS Assembly

1	<p>Using a tape measure, measure mounting hanger screw location heights on each side of the rack (see Figure 2-15 Hanger screw layout for UBS Macro carrier strip assembly on page 2-39). Measure down from the very top of the rack. Mark the following screw locations:</p> <ul style="list-style-type: none"> 95.25 mm (3.75 inches) for the top of the UBS Macro carrier strip assembly
2	<p>Partially insert an M5 x 12 mm screw into each location marked on the rack. Leave the screw heads extending 7 mm out from the rack surface.</p>
3	<p>Move the pallet with the unpacked UBS Macro carrier strip assembly and support near the rack so as to allow movement on both sides of the support and in front of the rack. Leave the carrier strip assembly on the support.</p>
4	<div style="display: flex; align-items: center;">  <div style="background-color: #00FFFF; padding: 5px; font-weight: bold; margin-right: 10px;">NOTE</div> </div> <p>The carrier strips allow four people to carefully lift the UBS Macro carrier strip assembly off the support and onto the rack. The assembly can also be lifted via some mechanical aid (hoist, etc.) attached to the lifting loops on the ends of the carrier strips.</p> <div style="display: flex; align-items: center; margin-top: 20px;">  <div style="background-color: #00FFFF; padding: 5px; font-weight: bold; margin-right: 10px;">NOTE</div> </div> <p>Four people, two on each side, are needed to lift the carrier strip assembly.</p> <p>Lift the UBS Macro carrier strip assembly up and off of the support and hang it on the rack (see Figure 2-16 Lifting and hanging the carrier strip assembly on the rack on page 2-40).</p>
5	<p>Using the carrier strip hanger screws previously installed in the rack, align the top carrier strip keyhole slots with the two hanger screws. Hang the carrier strip assembly on these two screws.</p>
6	<p>Insert a screw in the two bottom carrier strip keyhole slots (see Figure 2-17 Carrier strip assembly keyhole screw locations on page 2-41). Do not tighten the screws in carrier strip keyhole slots.</p>
7	<p>Insert screws in the 22 open slots of the various shelves of the carrier strip assembly. Using a T25 TORX driver, tighten these 22 screws to 4.77 N-m (42 in-lb).</p>

Continued

Procedure 2-4 Rack Mounting the Low-Capacity, +27 V DC UBS Macro BTS Assembly (Continued)

8	Using a T25 TORX driver, tighten the four screws in carrier strip keyhole slots to 4.77 N-m (42 in-lb).
9	<p>This step is optional and is only performed if there is a desire to remove the carrier strips from the frame. Remove the carrier strips from the frame as follows:</p> <ul style="list-style-type: none">• Using a 10 mm socket and ratchet, loosen and remove the 8 nuts that secure each carrier strip to the frame.• Remove the carrier strip.

Procedural reference diagrams

The following diagrams help clarify certain steps in [Procedure 2-4](#).

- [Figure 2-15 Hanger screw layout for UBS Macro carrier strip assembly on page 2-39](#)
- [Figure 2-16 Lifting and hanging the carrier strip assembly on the rack on page 2-40](#)
- [Figure 2-17 Carrier strip assembly keyhole screw locations on page 2-41](#)

Figure 2-15 shows hanger screw layout used for mounting the UBS Macro carrier strip assembly onto a 1400 mm or 1800 mm high EIA 19-inch rack.

Figure 2-15 Hanger screw layout for UBS Macro carrier strip assembly



NOTE

- 1. All dimensions are in millimeters
- 2. 1800 mm high rack shown. Dimension and hanger screw locations are also applicable for the 1400 mm rack

ti-cdma-06012.eps

Figure 2-16 shows four people lifting and hanging the UBS Macro carrier strip assembly on the rack.

Figure 2-16 Lifting and hanging the carrier strip assembly on the rack

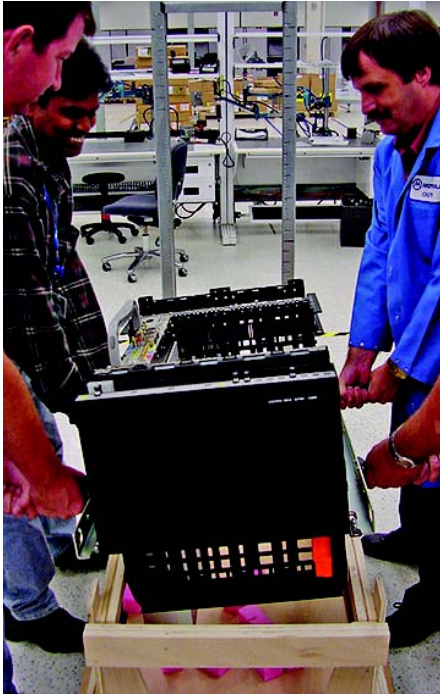

UBS Macro BTS Handles

ti-cdma-06386.eps

Figure 2-17 shows the keyhole screw locations in a rack mounted UBS Macro carrier strip assembly.

Figure 2-17 Carrier strip assembly keyhole screw locations

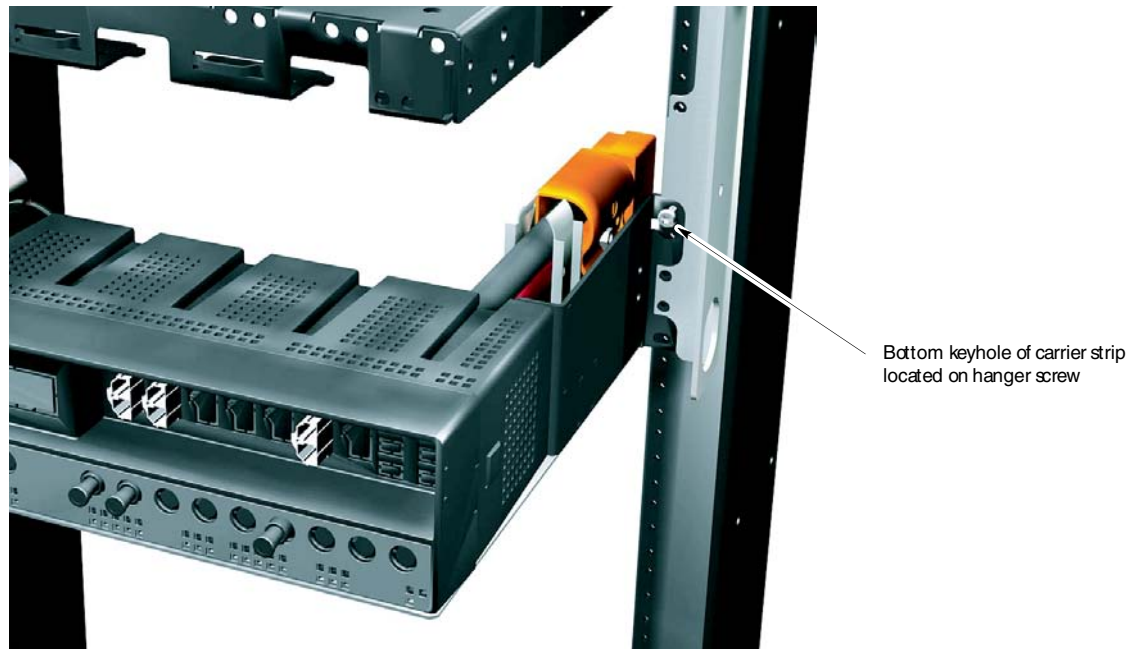

NOTE

1. Another carrier strip keyhole/hanger screw is located at the top of the right side carrier strip/rack rail. The left side carrier strip/rack rail has atop and bottom keyholes/hanger screws at the same heights as the right side. All four keyholes/hanger screws should be engaged at the same time.

ti-cdma-05870.eps

Task 6: Expanding the Low-capacity Frame



NOTE

If the initial UBS Macro BTS installation is for a low-capacity frame configuration, skip this task and go to [Task 7: Cabling the Optional PSM Shelf on page 2-43](#).

Perform this task only if the initial UBS Macro BTS installation is for a mid-capacity frame configuration.

Objective

The objective of Task 6 is to install the additional equipment required to expand the UBS Macro BTS low-capacity starter/expansion frame to the mid-capacity frame configuration.



NOTE

Currently a UBS Macro BTS low-capacity starter/expansion frame can only be expanded to mid-capacity. In the future, the low-capacity starter/expansion frames and mid-capacity frames will be expandable to high-capacity.

Procedure

Go to [Chapter 3 Low-to-Mid Capacity Frame Expansion Procedures](#) and perform all of the applicable procedures for expanding the low-capacity UBS Macro BTS starter/expansion frame to the mid-capacity frame configuration.

After all of the additional expansion equipment is installed, go to [Task 7: Cabling the Optional PSM Shelf on page 2-43](#) and continue performing the remaining tasks in sequential order.

Task 7: Cabling the Optional PSM Shelf

Objectives

The objectives of this procedure are as follows:

- For -48 V DC or 220 V AC UBS only.

Connect the +27 V DC power output cable from the rear of the PSM shelf to the +27 V DC power input cable on the rear of the PDU.

- For -48 V DC or 220 V AC UBS only

Connect the 50-conductor cable (supplied with PSM shelf) between the PSM shelf front panel ALARM/CONTROL connector and SSI front panel PSM connector.

Required items

The following items are required:

- 50-conductor cable (supplied with PSM shelf)
- Flat blade screw driver

Procedure

[Procedure 2-5](#) gives the procedure for performing Task 7.

Procedure 2-5 Procedure for Task 7

1	Connect the +27 V DC power output cable from the rear of the PSM shelf to the +27 V DC power input cable on the rear of the PDU. Mate Orange connectors together.
2	Connect the 50-conductor cable (supplied with PSM shelf) between the PSM shelf front panel ALARM/CONTROL connector and SSI front panel PSM connector. Refer to Figure 2-3 and Figure 2-4 for the connector locations on the PSM shelf front panel and on the SSI.

Tasks 8-9: Connecting TX/RX Antennas

Objectives

The objectives of performing Tasks 8-9 are as follows:

- Install the external antenna cables to the Integrated Duplexer RX Filters (IDRFs).
- Install terminators on the IDRFs.

The site configuration/characteristics determines the IDRF usage.

Required items

The following items are required:

- External TX and RX 50 Ohm coaxial cables with type N connectors (customer supplied)
- 0.25 W, 50 Ohm, SMA-type male terminators (customer supplied) for unused directional coupler port connectors
- 50 W N-type male terminator (customer supplied) for unused TX/RX connectors
- SMA breakover wrench
- 19 mm open-end hex wrench (N-type connector)

Location of antenna connectors

The top view of [Figure 2-1](#) and [Figure 2-2](#) show the location of the UBS Macro BTS antenna connectors on the top of the IDRF.

Procedure

The procedure for performing Tasks 8-9 is as follows.

Procedure 2-6 Procedure for Tasks 8-9

- | | |
|----------|---|
| 1 | Route the customer supplied TX/RX main and RX diversity antenna cables to the top of the Integrated Duplexer RX Filters (IDRFs), located at the top of the frame. |
|----------|---|

Continued

Procedure 2-6 Procedure for Tasks 8-9 (Continued)

2	<p>Connect each antenna cable to the corresponding IDRf type N connector. Refer to Figure 2-1 or Figure 2-2, whichever is applicable, for the location of the UBS Macro BTS antenna connectors on the top of the IDRf. Using a 19 mm open-end hex wrench, tighten the cable connectors to 4.3 N-m (38 in-lb).</p> <div data-bbox="480 431 580 544"> </div> <div data-bbox="604 457 842 508"> <p>NOTE</p> </div> <p>The IDRfs are not labeled for a sector. To determine the sector for each IDRf, look at the color code of the XMI TX and RX cables connected to the bottom of the IDRf. Refer to Table 2-2 for the mapping of the cable color to the sector (Red = sector 1, Blue = sector 2, Yellow = sector 3). The sectors can also be determined by tracing those XMI cables back to the XMI TX and RX ports, which are labeled as TX1 and RX1 for sector 1, TX2 and RX2 for sector 2, and TX3 and RX3 for sector 3.</p>
3	<p>Connect customer supplied 0.25 W, 50 Ohm, SMA-type terminators to any unused directional coupler port connectors on the top of the IDRfs.</p>
4	<p>For any unused TX/RX connector on an IDRf, install a 50 W N-type terminator (customer supplied).</p>

Tasks 10-13: Connecting RGPS, Spans, Customer Alarms

Objectives



CAUTION

The SSI provides only secondary surge protection for the RGPS and T1/E1 span connections. The customer is responsible for providing primary surge protection.

The objectives of performing Tasks 10–13 are as follows:

- Install RGPS cable (AA) between the RGPS cable lightning arrester and the UBS Macro BTS.
- Install T1/E1 balanced Span I/O cable (W) between the UBS Macro BTS and the site span line interconnect equipment.
- Install E1 unbalanced Span I/O coaxial cables (customer supplied) between the UBS Macro BTS and the site span line interconnect equipment.
- Install Customer Alarm Input/Output (IP/OP) cables (X) between the UBS Macro BTS and the Customer IP/OP interconnect equipment.

The site configuration/characteristics determines whether the cables in Tasks 10-13 are to be installed.

Cabling options

The site characteristics determine the use of cables AA, W and X.

The RGPS cable (AA) is optional and used only when the optional RGPS head is used.

The T1/E1 balanced Span I/O cable (W) can carry up to 8 spans, but the UBS Macro BTS currently supports only up to 4 spans. This is also true for E1 unbalanced Span I/O coaxial cables (customer supplied).



NOTE

For Span I/O cable (W), the minimum size of span line wires is 26 AWG.

The usage and quantity of Customer Alarm Input/Output (IP/OP) cables (X) is determined by the customer.

Required items

The following items are required:

- Cable AA - Part number 3086433H12
- Cable W - Part number CGDS19797321
- Cable X - Part number CGDS19797321



NOTE

All SSI cable connectors with jack-screws require a flat-blade driver and should be tightened to 1.02 N-m (9 in-lb).

Location of cables AA, W and X

Figure 2-3 SSI front panel connectors on page 2-9 shows the connector locations on the front panel of the SSI for: RGPS cable (AA), T1/E1 balanced span line cable (W), E1 unbalanced span line coaxial cables, and customer alarm cable (X).

The optional RGPS cable (AA) has a 15-pin D-connector on one end that connects to the RGPS connector, located on the front of the SSI. The other cable end has loose wires. This end is routed to the RGPS lightning arrester, where the wires connect. Refer to Figure 2-6 through Figure 2-11, Table 2-9 and Table 2-10 for RGPS cable (AA) details.

Details for cables (W) and (X) are provided in this task section.

Balanced T1/E1 cable (W) details

Figure 2-18 and Table 2-11 show the pin and signal information for cable W.

Figure 2-18 T1/E1 balanced span line cable (W) pin numbering

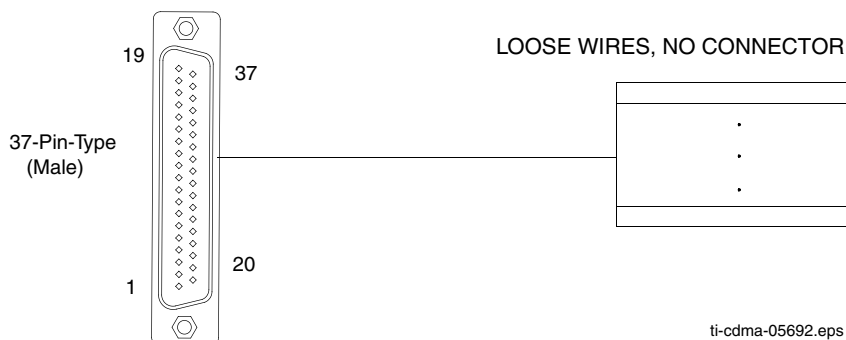

For E1 unbalanced 75-Ohm BNC connector locations and labeling on the daughter card, refer to [Figure 2-3 SSI front panel connectors on page 2-9](#).

[Table 2-11](#) also shows the correlation between spans and the E1 unbalanced Span I/O coaxial BNC connectors.

Table 2-11 T1/E1 I/O cable W (span) signal and pin information

Span number	Signal name	T1/E1 Balanced Span 36-Cond Shielded Twisted Pair Cable (W) 37-Pin D-Sub Connector		E1 Unbalanced 75-Ohm Coaxial Cable BNC Connection (RING is GND/shield)
		Pin	Wire Color	
1	TX1_TIP	1	White/Blue	TX1
	TX1_RING	20	Blue/White	
	RX1_TIP	12	Black/Orange	RX1
	RX1_RING	30	Orange/Black	
2	TX2_TIP	2	White/Orange	TX2
	TX2_RING	21	Orange/White	
	RX2_TIP	13	Black/Green	RX2
	RX2_RING	31	Green/Black	
3	TX3_TIP	3	White/Green	TX3
	TX3_RING	22	Green/White	
	RX3_TIP	14	Black/Brown	RX3
	RX3_RING	32	Brown/Black	
4	TX4_TIP	4	White/Brown	TX4
	TX4_RING	23	Brown/White	
	RX4_TIP	15	Black/Gray	RX4
	RX4_RING	33	Gray/Black	
5	TX5_TIP	5	White/Gray	TX5
	TX5_RING	24	Gray/White	
	RX5_TIP	16	Yellow/Blue	RX5
	RX5_RING	34	Blue/Yellow	
6	TX6_TIP	6	Red/Blue	TX6
	TX6_RING	25	Blue/Red	
	RX6_TIP	17	Yellow/Orange	RX6
	RX6_RING	35	Orange/Yellow	

Continued

Table 2-11 T1/E1 I/O cable W (span) signal and pin information (Continued)

Span number	Signal name	T1/E1 Balanced Span 36-Cond Shielded Twisted Pair Cable (W) 37-Pin D-Sub Connector		E1 Unbalanced 75-Ohm Coaxial Cable BNC Connection (RING is GND/shield)
		Pin	Wire Color	
7	TX7_TIP	7	Red/Orange	TX7
	TX7_RING	26	Orange/Red	
	RX7_TIP	18	Yellow/Green	RX7
	RX7_RING	36	Green/Yellow	
8	TX8_TIP	8	Red/Green	TX8
	TX8_RING	27	Green/Red	
	RX8_TIP	19	Yellow/Brown	RX8
	RX8_RING	37	Brown/Yellow	
	Ground	9	Red/Brown	
	Ground	28	Brown/Red	
	Not Connected	10		
	Ground	11	Black/Blue	
	Ground	29	Blue/Black	

Customer alarm input/output (IP/OP) cable (X) details

Alarm connectors

There are two ALARM connectors on the UBS Macro SSI:

- CUSTOMER IP 1-12 OP 1-4 connector
- CUSTOMER IP 13-24 OP 5-8 connector

Each ALARM connector provides 12 inputs and 4 outputs. A total of 24 inputs and 8 outputs are available.

Function

ALARM connectors provide for Customer Defined Alarm Inputs and Outputs. The customer can connect BTS site alarm input sensors and output devices to the UBS Macro BTS, thus providing alarm reporting of active sensors as well as controlling output devices.

The SSI detects signals from customer input sensors and reports the detected signals to the DMI controller, which in turn reports the detected alarm to the OMC-R, where it is displayed as defined by the customer.

The SSI also provides switched relay contacts to customer output devices. The SSI controls relay contacts according to output control signals from the DMI controller, in response to customer defined commands entered at the OMC-R.

Input connections

Each input consists of a wire/pin pair (that is, input/Gnd). To ensure proper operation, each pair to be used must be connected to an external sensor that provides a dry-contact closure. The customer sensor output connects between an optically isolated 5 V DC signal and an isolated return.

For an OPEN circuit (logic **0**) between pins:

- There is 10 K Ohms or greater across the input pair.
- The signal to ground voltage is +5 V DC.

For a CLOSED circuit (logic **1**) between pins:

- There is 1 K Ohms or less across the input pair.
- The signal to ground current is a maximum of 9 mA.

Either of the above states can be defined by the customer in system software as an alarm condition.

Output connections

Each output consists of 3-wires/pins:

- COM
- NC
- NO

The customer output device control inputs connect between the common (COM) and either the normally closed (NC) or normally open (NO) contacts of a relay. The NC and NO state for relay contacts occurs when the relay coil is not energized.

Relay contacts are load rated for a maximum of 1 A at 24 V DC and 0.5 A at 50 V DC.

The toggling of relay contacts to the opposite state is controlled by system software.

Pins and signals

Figure 2-19, Table 2-12 and Table 2-13 show the pin and signal information for cable X.

Figure 2-19 Customer alarm cable (X) pin numbering

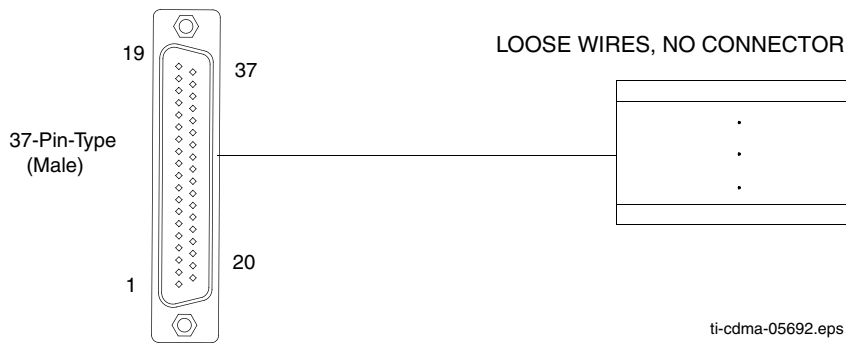

ti-cdma-05692.eps

Table 2-12 Customer alarm cable (X) pinout for customer IP 1-12 OP 1-4

37-Pin D-Sub Pin number	Signal Description	Wire Color	37Pin D-Sub Pin number	Signal Description	Wire Color
1	Customer Input 1	White/Blue	20	Input 1 Gnd	Blue/White
2	Customer Input 2	White/Orange	21	Input 2 Gnd	Orange/White
3	Customer Input 3	White/Green	22	Input 3 Gnd	Green/White
4	Customer Input 4	White/Brown	23	Input 4 Gnd	Brown/White
5	Customer Input 5	White/Gray	24	Input 5 Gnd	Gray/White
6	Customer Input 6	Red/Blue	25	Input 6 Gnd	Blue/Red
7	Customer Input 7	Red/Orange	26	Input 7 Gnd	Orange/Red
8	Customer Input 8	Red/Green	27	Input 8 Gnd	Green/Red
9	Customer Input 9	Red/Brown	28	Input 9 Gnd	Brown/Red
10	Not Connected		29	Customer Output NC 1	Blue/Black
11	Customer Output NO 1	Black/Blue	30	Customer Output Common 1	Orange/Black
12	Customer Output NO 2	Black/Orange	31	Customer Output Common 2	Green/Black

Continued

Table 2-12 Customer alarm cable (X) pinout for customer IP 1-12 OP 1-4 (Continued)

37-Pin D-Sub Pin number	Signal Description	Wire Color	37Pin D-Sub Pin number	Signal Description	Wire Color
13	Customer Output NC 2	Black/Green	32	Customer Output NC 3	Brown/Black
14	Customer Output NO 3	Black/Brown	33	Customer Output Common 3	Gray/Black
15	Customer Output NO 4	Black/Gray	34	Customer Output Common 4	Blue/Yellow
16	Customer Output NC 4	Yellow/Blue			
17	Customer Input 10	Yellow/Orange	35	Input 10 Gnd	Orange/Yellow
18	Customer Input 11	Yellow/Green	36	Input 11 Gnd	Green/Yellow
19	Customer Input 12	Yellow/Brown	37	Input 12 Gnd	Brown/Yellow

Table 2-13 Customer alarm cable (X) pinout for customer IP 13-24 OP 5-8

37-Pin D-Sub Pin number	Signal Description	Wire Color	37-Pin D-Sub Pin number	Signal Description	Wire Color
1	Customer Input 13	White/Blue	20	Input 13 Gnd	Blue/White
2	Customer Input 14	White/Orange	21	Input 14 Gnd	Orange/White
3	Customer Input 15	White/Green	22	Input 15 Gnd	Green/White
4	Customer Input 16	White/Brown	23	Input 16 Gnd	Brown/White
5	Customer Input 17	White/Gray	24	Input 17 Gnd	Gray/White
6	Customer Input 18	Red/Blue	25	Input 18 Gnd	Blue/Red
7	Customer Input 19	Red/Orange	26	Input 19 Gnd	Orange/Red
8	Customer Input 20	Red/Green	27	Input 20 Gnd	Green/Red
9	Customer Input 21	Red/Brown	28	Input 21 Gnd	Brown/Red

Continued

Table 2-13 Customer alarm cable (X) pinout for customer IP 13-24 OP 5-8 (Continued)

37-Pin D-Sub Pin number	Signal Description	Wire Color	37-Pin D-Sub Pin number	Signal Description	Wire Color
10	Not Connected		29	Customer Output NC 5	Blue/Black
11	Customer Output NO 5	Black/Blue	30	Customer Output Common 5	Orange/Black
12	Customer Output NO 6	Black/Orange	31	Customer Output Common 6	Green/Black
13	Customer Output NC 6	Black/Green	32	Customer Output NC 7	Brown/Black
14	Customer Output NO 7	Black/Brown	33	Customer Output Common 7	Gray/Black
15	Customer Output NO 8	Black/Gray	34	Customer Output Common 8	Blue/Yellow
16	Customer Output NC 8	Yellow/Blue			
17	Customer Input 22	Yellow/Orange	35	Input 22 Gnd	Orange/Yellow
18	Customer Input 23	Yellow/Green	36	Input 23 Gnd	Green/Yellow
19	Customer Input 24	Yellow/Brown	37	Input 24 Gnd	Brown/Yellow

Procedure



Perform Tasks 10-13 as given in [Procedure 2-7](#).

Procedure 2-7 Procedure for Tasks 10-13

1	Connect the 15-pin D-connector end of cable (AA) to the RGPS connector on the front of the SSI. Refer to Figure 2-3 for the connector location on the SSI.
2	Route the loose end of cable (AA) to the RGPS lightning arrester and connect the wires there. Refer to Figure 2-6 through Figure 2-11 , Table 2-9 and Table 2-10 .
3	For T1/E1 balanced span line connections, go to step 4 . For E1 unbalanced span line connections, go to step 7 .

Continued

Procedure 2-7 Procedure for Tasks 10-13 (Continued)

4	Connect the 37-pin D-connector end of cable (W) to the SPAN connector on the front of the SSI. Refer to Figure 2-3 for the connector location on the SSI.
5	<p>Route the loose end of cable (W) to the customer span line interconnect equipment and connect the wires. Refer to Table 2-11.</p> <div data-bbox="443 451 804 557">  <div data-bbox="568 476 804 523" style="background-color: #00FFFF; padding: 5px; display: inline-block;">NOTE</div> </div> <p>The UBS Macro BTS currently supports only up to 4 spans.</p>
6	Go to step 9 .
7	Connect E1 unbalanced Span I/O coaxial cables (customer supplied) to the corresponding BNC connector on the SSI E1 daughter card. Refer to Figure 2-3 for the BNC connector locations on the SSI. Also, refer to Table 2-11 for correlation between spans and the E1 unbalanced span I/O coaxial BNC connectors.
8	<p>Route the other ends of the span I/O coaxial cables to the customer span line interconnect equipment and connect the cables.</p> <div data-bbox="443 910 804 1017">  <div data-bbox="568 936 804 983" style="background-color: #00FFFF; padding: 5px; display: inline-block;">NOTE</div> </div> <p>The UBS Macro BTS currently only supports up to 4 spans.</p>
9	Connect the 37-pin D-connector of the Customer Alarm Input/Output (IP/OP) cables (X) to the corresponding CUSTOMER IP 1-12 OP 1-4 connector and CUSTOMER IP 13-24 OP 5-8 connector on the front of the SSI.
10	Route the loose end of cable (X) to the Customer IP/OP interconnect equipment and connect the wires. Refer to Figure 2-3 for the CUSTOMER IP/OP connector locations on the SSI. Also, refer to Table 2-12 and Table 2-13 .

Task 14: Connecting +27 V DC Power

Objectives

Task 14 is performed for +27 V DC UBS Macro BTS only.

The objectives of this procedure are as follows:

- Attaching the contact/lugs, connector and cable clamp on the +27 V DC power input cable wires.
- Connecting the +27 V DC input power cable to the rear of the PDU.
- Routing the loose ends of the wires to the site +27 V DC source for connection.

Frame power cables and connector information

The wire gauge (that is, diameter) depends on the required length of the DC power cable (DC). Refer to [Table 2-8](#) for the correct wire size.

The DC connector contact/lug size depends on the wire gauge used for the DC power cable (DC). Refer to [Table 2-14](#) for DC connector contact/lug part information.

In order to minimize current imbalance between the feed (+V) and return (-V) wires used in the cable:

- Ensure that the wire size, length and gage, of each wire used in the cable are the same.
- Ensure that contacts/lugs used in the connector are identical and match the gauge of the wire.



NOTE

Motorola recommends using 2/0 AWG cables for short cable runs; less than 661.11 cm (21.69 ft).

Table 2-14 +27 V DC connector (Orange) parts information

Item Description	Part Number	Qty
Orange DC connector housing	Anderson Power Products Mfr Part# 932, or Allied Electronics Stk# 803-0097	1 per +27 V DC power feed

Continued

Table 2-14 +27 V DC connector (Orange) parts information (Continued)

Item Description	Part Number	Qty
AWG 2/0 connector contact/lug	Anderson Power Products Mfr Part# 907, or Allied Electronics Stk# 803-0500	2 per DC connector housing
AWG 3/0 connector contact/lug	Anderson Power Products Mfr Part# 916, or Allied Electronics Stk# 803-0502	2 per DC connector housing
AWG 4/0 connector contact/lug	Anderson Power Products Mfr Part# 908, or Allied Electronics Stk# 803-0504	2 per DC connector housing
Cable clamp for two single conductors with hardware	Anderson Power Products Mfr Part# 996G1	1 per +27 V DC power feed

Required items

The following items are required:

- One +27 V DC Power Input Cable (DC) - customer supplied. The wire size, length and gauge, used for cable (DC) depends on site characteristics (see [Table 2-8](#)).



NOTE

Motorola recommends the use of Red wire for feed (+V) and Black wire for return (-V).

- Two contacts/lugs – customer supplied. Contact/lug fastens to wire end and is inserted into DC connector housing. For contact/lug part number (refer to [Table 2-14](#)). Contact/lug size must match the gauge of the wire being used.
- One DC connector housing – customer supplied. Use Anderson SB350 connector housing (Orange color) or equivalent.
- DC connector cable clamps for power cable (see [Table 2-14](#) or [Table 2-15](#) for part information).
- Crimper tool - Anderson Power Products part number 1368 - Hydraulic hand tool, maximum cable size of 300 MCM
- Wire stripper/cutters.
- Digital Multi-Meter (DMM) Fluke Model 8062A with Y8134 test lead kit or equivalent; used for precision DC and AC measurements, requiring 4-1/2 digits.

Power cabling and tie down requirements

To control the inductance at the BTS DC power input due to the spacing between wires used in the +27 V DC Power Input Cable (DC), the feed (+V) and return (-V) wires must be bound together at intervals of 1 meter or less. Refer to [Figure 2-20](#).

Figure 2-20 +27 V DC power input cable (DC) wire tie-wrap example

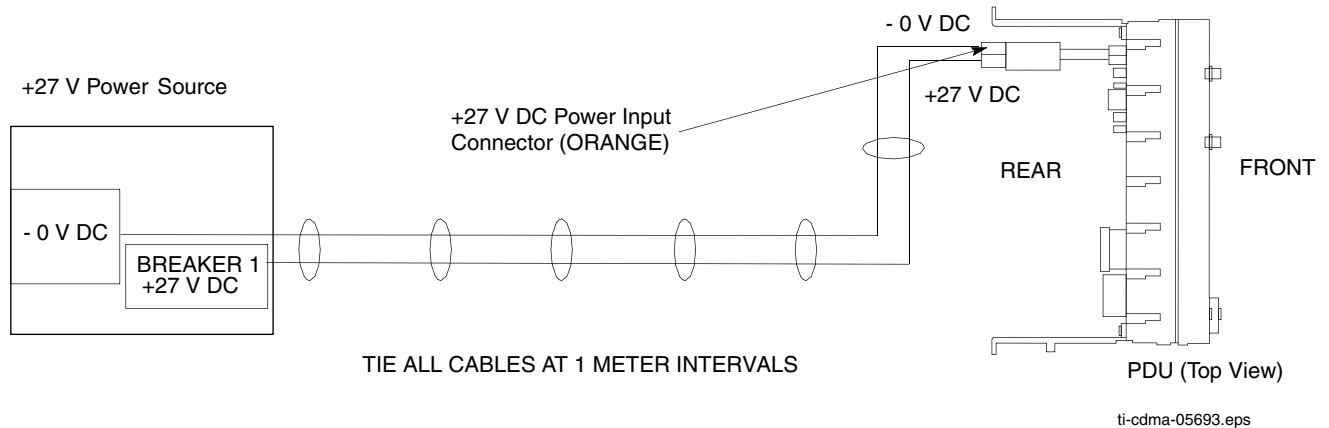

Contact/lug, DC connector housing and PDU input power

[Figure 2-21](#) shows the lugs and DC connector housing. This figure also shows the location at which the +27 V DC Input Power Cable (DC) connects to the rear of the PDU.

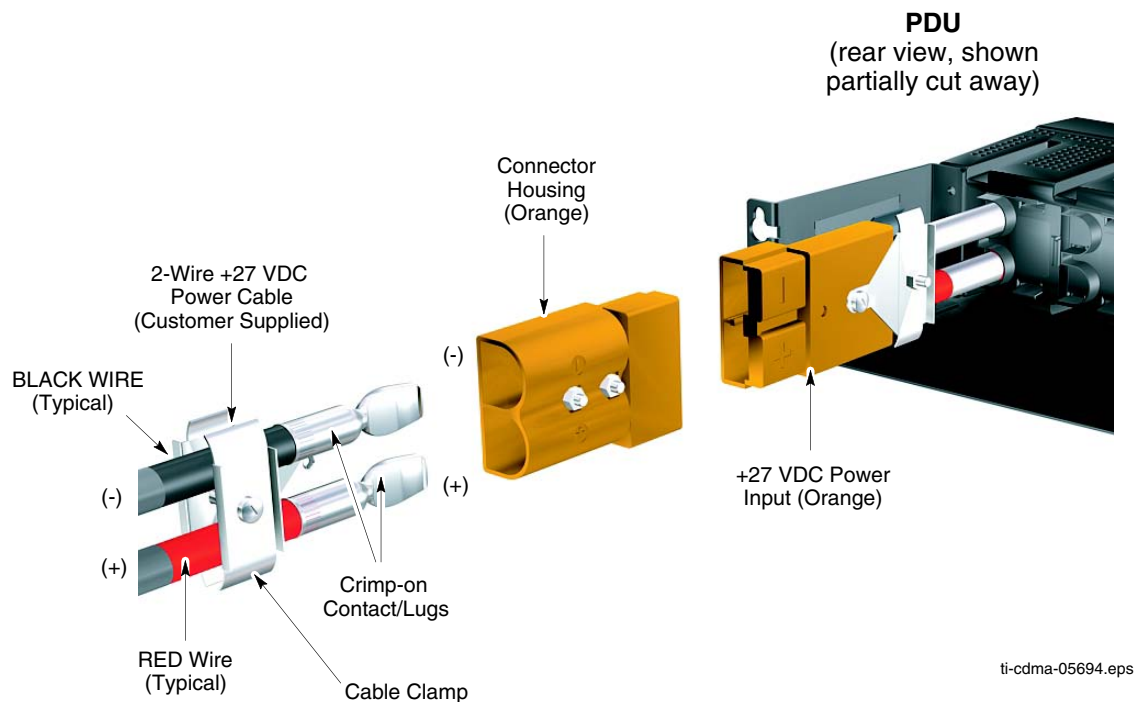
Figure 2-21 +27 V DC power input cable (DC) connector and connection to PDU

Procedure

Perform the Task 14 as given in [Procedure 2-8](#).



WARNING

- Do not wear a wrist strap when servicing the power supplies or power distribution cabling.
- Ensure that the source for the DC power is in the OFF position.
- Ensure that all of the PDU circuit breakers are OFF.

Procedure 2-8 Procedure for Task 14

- | | |
|----------|--|
| 1 | Ensure that the BTS ground cable (DD) is connected between the rack and the Master Ground Bar (refer to Task 3). |
|----------|--|

Continued

Procedure 2-8 Procedure for Task 14 (Continued)

2	Ensure that the +27 V DC Power Input Cable (DC) is NOT connected to the main +27 V DC power source. Turn OFF the main +27 V DC power source.
3	Remove the components from the DC connector package.
4	Strip 35 mm of insulation from the negative (-V) and positive (+V) wires of the power cable.
5	Place a DC contact/lug on the negative (-V) and positive (+V) wires of the power cable. Refer to Figure 2-21 .
6	Using the appropriate crimping tool, crimp the DC contact/lug on to the wires.
7	Observe the negative (-V) and positive (+V) wire polarities and insert the DC contacts/lugs into the DC connector housing until an audible click is heard. Refer to Figure 2-21 .
8	Verify the positive (+V) wire is installed in the positive position and the negative (-V) wire is installed in the negative (-) position on the connector housing.
9	Ensure that the wires are firmly fastened to the DC connector housing.
10	Tie the positive (+V) and negative (-V) wires of the cable together as shown in Figure 2-20 .
11	Route the loose end of the +27 V DC Power Input Cable (DC) to the site +27 V DC source and connect the wires to the source.
12	Verify that proper polarity is maintained from the +27 V DC power source to the UBS Macro BTS.
13	Use a Digital Multi-Meter (DMM) to measure the voltage of the DC connector housing that was installed in step 7 . Perform the following: <ul style="list-style-type: none"> ● Set the DMM to measure 27 V DC. ● Connect the DMM negative (GND/common) lead to the (-) terminal of the cable connector. ● Connect the DMM positive lead to the (+) terminal of the cable connector.
14	Turn on the main +27 V DC power source.
15	Observe the DMM and verify that the voltage is nominally +27 V (range = +26 to +28 V).
16	Turn off the main +27 V DC power source.
17	Disconnect the DMM from the cable connector.
18	Connect +27 V DC Power Input Cable (DC) connector to the +27 V DC input power cable on the rear of the PDU; Orange connectors mate. Refer to Figure 2-21 .

Task 15: Connecting -48 V DC Power

Objectives

Task 15 is performed for -48 V DC UBS Macro BTS only.

The objectives of this procedure are as follows:

- Attaching the contact/lugs and connector on the -48 V DC power input cable wires.
- Connecting the -48 V DC input power cable to the rear of the -48 V DC PSM shelf.
- Routing the loose ends of the wires to the site -48 V DC source for connection to the source.



NOTE

Verify that the +27 V DC output power cable from the PSM shelf is already connected to the PDU +27 V DC input power cable. This was performed during Tasks 4-7.

Frame power cables and connector information

The wire gauge (that is, diameter) depends on the required length of the DC power cable (CC). Refer to [Table 2-8](#) for the correct wire size.

The DC connector contact/lug size depends on the wire gauge used for the DC power cable (CC). Refer to [Table 2-15](#) for DC connector contact/lug part information.

In order to minimize current imbalance between the feed (-V) and return (+V) wires used in the cable:

- Ensure that the wire size, length and gauge, of each wire used in the cable are the same.
- Ensure that contacts/lugs used in the connector are identical and match the gauge of the wire.



NOTE

Motorola recommends using 2/0 AWG cables for short cable runs; less than 661.11 cm (21.69 ft).

Table 2-15 -48 V DC connector (Blue) parts information

Item Description	Part Number	Qty
Blue DC connector housing	Anderson Power Products Mfr Part# 912, or Allied Electronics Stk# 803-0492	1 per -48 V DC power feed
AWG 2/0 connector contact/lug	Anderson Power Products Mfr Part# 907, or Allied Electronics Stk# 803-0500	2 per DC connector housing
AWG 3/0 connector contact/lug	Anderson Power Products Mfr Part# 916, or Allied Electronics Stk# 803-0502	2 per DC connector housing
AWG 4/0 connector contact/lug	Anderson Power Products Mfr Part# 908, or Allied Electronics Stk# 803-0504	2 per DC connector housing
Cable clamp for two single conductors with hardware	Anderson Power Products Mfr Part# 996G1	1 per -48 V DC power feed

Required items

The following items are required:

- One -48 V DC Power Input Cable (CC) - customer supplied. The wire size, length and gauge, used for cable (CC) depends on site characteristics (see [Table 2-8](#)).



NOTE

Motorola recommends the use of blue wire for feed (-V) and black wire for return (+V).

- Two Contacts/Lugs – customer supplied. Contact/lug fastens to wire end and is inserted into DC connector housing. For contact/lug part number (refer to [Table 2-15](#)). Contact/lug size must match the gauge of the wire being used.
- One DC Connector Housing – supplied with UBS BTS. Use Anderson SB350 connector housing (blue color) or equivalent.
- Crimper tool - Anderson Power Products part number 1368 - Hydraulic hand tool, maximum cable size of 300 MCM
- Wire stripper/cutters.
- Digital Multi-Meter (DMM) Fluke Model 8062A with Y8134 test lead kit or equivalent; used for precision DC and AC measurements, requiring 4-1/2 digits.

Power cabling and tie down requirements

To control the inductance at the BTS DC power input due to the spacing between wires used in the -48 V DC Power Input Cable (CC), the feed (-V) and return (+V) wires must be bound together at intervals of 1 meter or less. Refer to [Figure 2-22](#).

Figure 2-22 48 V DC power input cable (CC) wire tie-wrap example

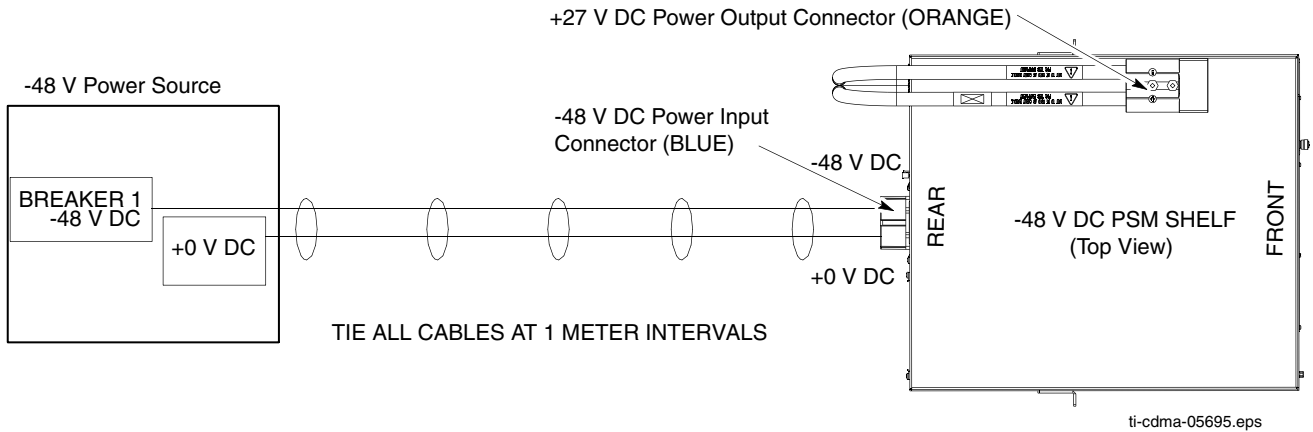

Contact/lug, DC connector housing and PDU input power

[Figure 2-23](#) shows the lugs and DC connector housing. This figure also shows the location at which the -48 V DC Input Power Cable (CC) connects to the rear of the PDU.

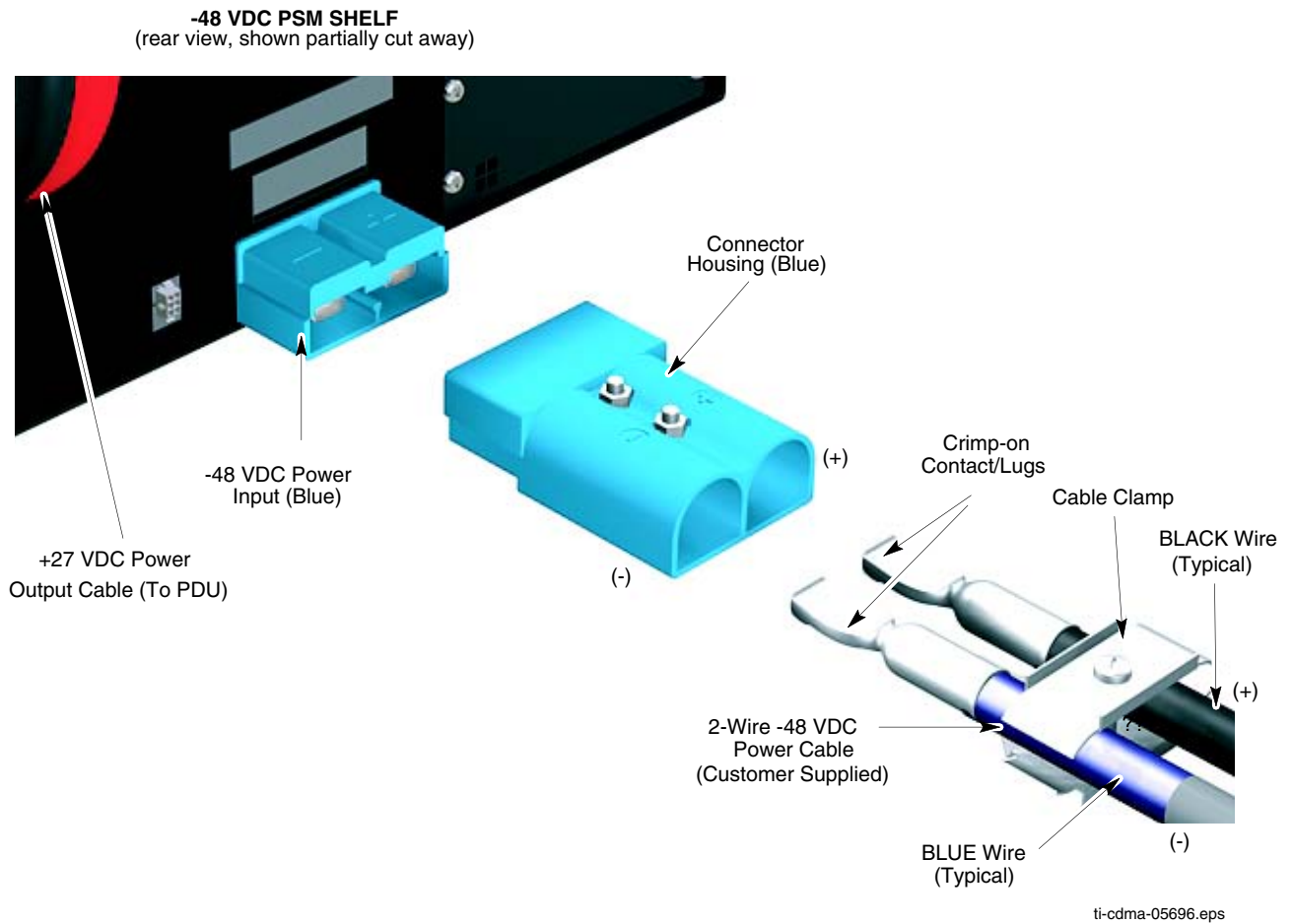
Figure 2-23 48 V DC power input cable (CC) connector and connection to PSM shelf

Procedure

Performing Task 15 as given in [Procedure 2-9](#).



WARNING

- Do not wear a wrist strap when servicing the power supplies or power distribution cabling.
- Ensure that the source for the DC power is in the OFF position.
- Ensure that all of the PDU circuit breakers are OFF.

Procedure 2-9 Procedure for Task 15

1	Ensure that the BTS ground cable (DD) is connected between the rack and the Master Ground Bar (refer to Task 3).
2	Ensure that the -48 V DC Power Input Cable (CC) is NOT connected to the main -48 V DC power source. Turn OFF the main -48 V DC power source.
3	Remove the components from the DC connector package.
4	Strip 35 mm of insulation from the negative (-V) and positive (+V) wires of the power cable.
5	Place a DC contact/lug on the negative (-V) and positive (+V) wires of the power cable. Refer to Figure 2-23 .
6	Using the appropriate crimping tool, crimp the DC contact/lug on to the wires.
7	Observe the negative (-V) and positive (+V) wire polarities and insert the DC contacts/lugs into the DC connector housing until a click sound is heard. Refer to Figure 2-23 .
8	Verify the positive (+V) wire is installed in the positive position and the negative (-V) wire is installed in the negative (-) position on the connector housing.
9	Ensure that the wires are firmly fastened to the DC connector housing.
10	Tie the positive (+V) and negative (-V) wires of the cable together as shown in Figure 2-22 .
11	Route the loose end of the -48 V DC Power Input Cable (CC) to the site -48 V DC source and connect the wires to the source.
12	Verify that proper polarity is maintained from the -48 V DC power source to the UBS Macro BTS.
13	Use a Digital Multi-Meter (DMM) to measure the voltage of the DC connector housing that was installed in step 7 . Perform the following: <ul style="list-style-type: none"> ● Set the DMM to measure 48 V DC. ● Connect the DMM negative (GND/common) lead to the (-) terminal of the cable connector. ● Connect the DMM positive lead to the (+) terminal of the cable connector.
14	Turn on the main -48 V DC power source.
15	Observe the DMM and verify that the voltage is nominally +48 V (range = +40 to +60 V).
16	Turn off the main -48 V DC power source.
17	Disconnect the DMM from the cable connector.
18	Connect -48 V DC Power Input Cable (CC) connector to the -48 V DC input power connector on the rear of the PSM shelf; blue connectors mate. Refer to Figure 2-23 .

Task 16: Connecting 220 V AC Power

Objectives

Task 16 is performed for 220 V AC UBS Macro BTS only.

The objectives of this procedure are as follows:

- Attaching customer supplied wiring and conduit for 220 V AC lines.
- Connecting wires and required insertion bridges to the AC INPUT terminal block on the rear of the AC PSM shelf.
- Routing the loose ends of the wires to the site 220 V AC source for connection to the source.



NOTE

Verify that the +27 V DC output power cable from the PSM shelf is already connected to the PDU +27 V DC input power cable. This was performed during Tasks 4-7.

Frame AC power cables and wiring information

The AC PSM shelf and AC PSMs can operate with the following AC power inputs:

- Input AC Voltage Range: 154 V AC to 300 V AC
- Single-Phase
- 3-Phase STAR
- 3-Phase DELTA

Consider the following AC power input circuit characteristics:

- The AC PSM shelf terminal block has seven terminals; one for Ground plus six for AC line wires and insertion bridges.
- The AC PSM shelf terminal block Ground terminal can accommodate a wire size range of 2 AWG to 10 AWG.
- The AC PSM shelf terminal block AC line terminals can accommodate a wire size range of 2 AWG to 10 AWG.

- Input AC cable sizing should be determined by Local Electrical Codes, using 90 C minimum rated conductors, and de-rating for 50 C operation.
- The customer must provide a disconnect device and an over current protection device for the AC circuit supplying the UBS Macro BTS. A circuit breaker size of 30 Amperes is recommended, or as appropriate set by Local Electrical Code.

Required items

The following items are required:

- Conduit - customer supplied
- Wire for Ground and AC lines - customer supplied
- Insertion bridges – supplied with AC PSM shelf; two 3-position bridges and three 2-position bridges
- T20 TORX bit with 12-inch extension
- Flat blade screwdriver
- Wire stripper/cutters

AC PSM shelf AC power input detail

Figure 2-24 shows the location of the AC PSM shelf AC power input terminals and wiring details for:

- Single-Phase
- 3-Phase STAR
- 3-Phase DELTA

Figure 2-24 AC PSM shelf AC power input terminal block and wiring details

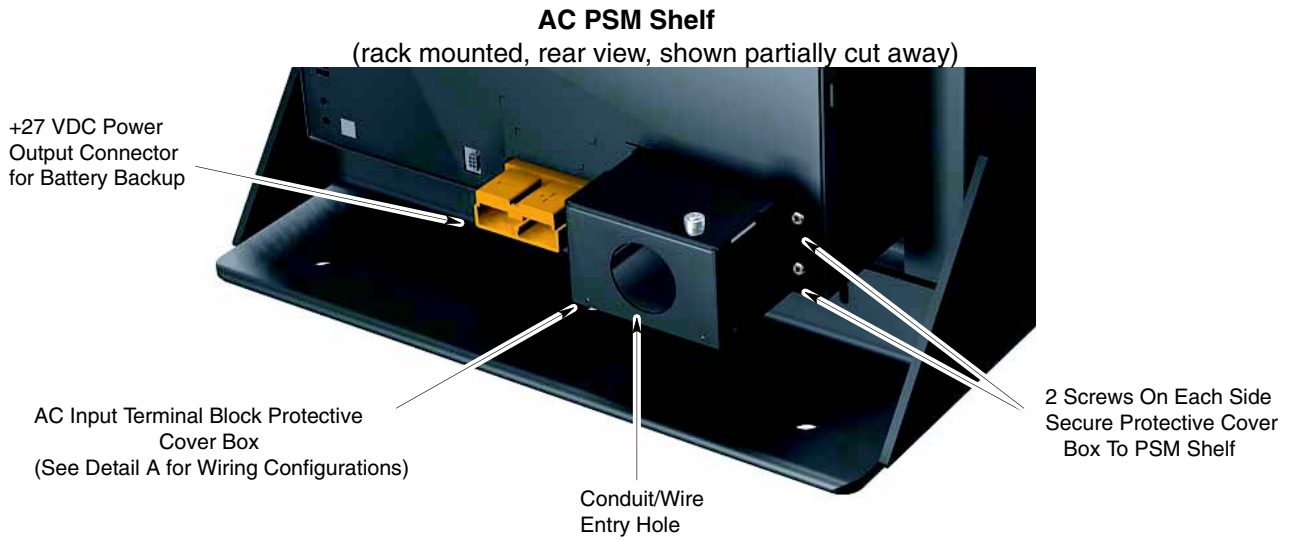

Detail A - AC Input Terminal Wiring Configurations (protective cover box removed)

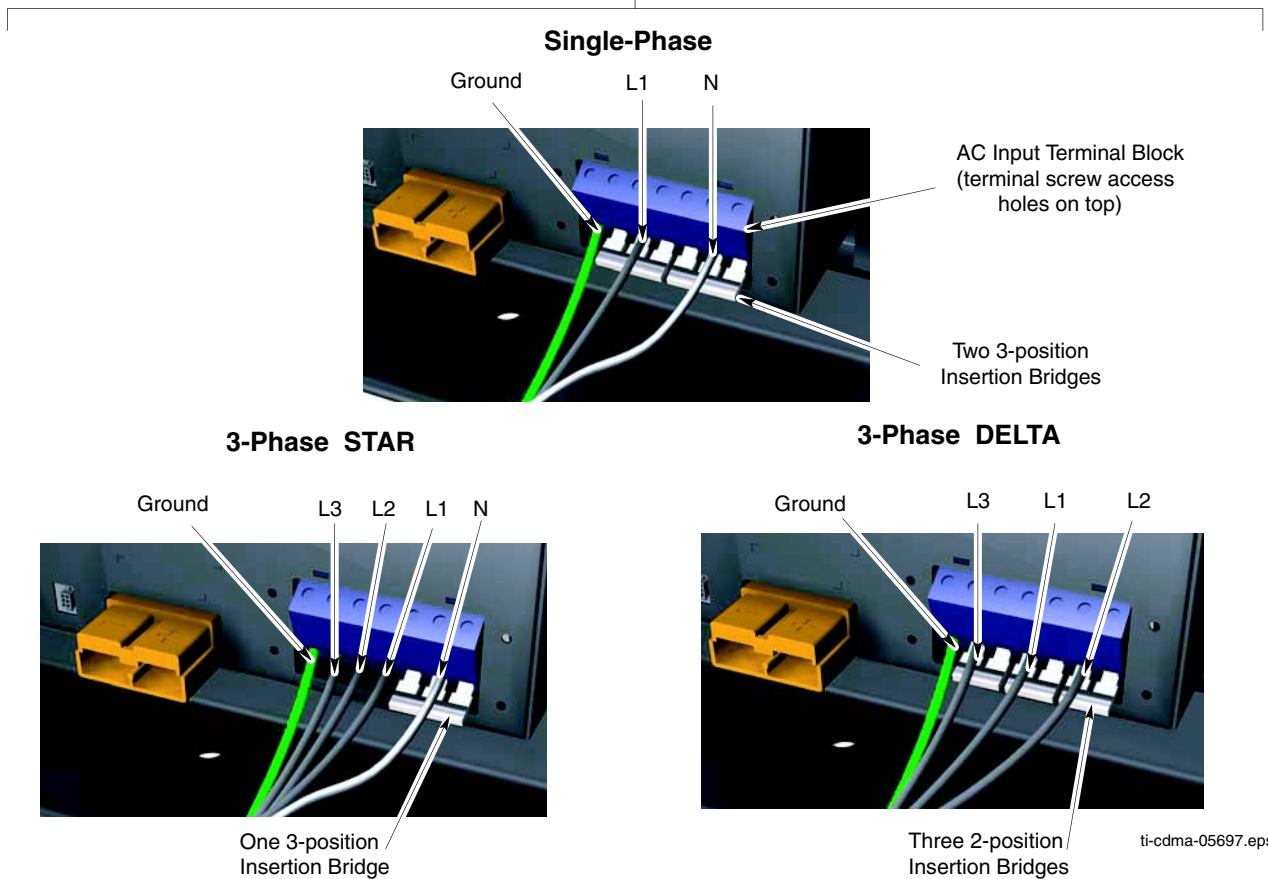

Procedure

Perform Task 16 as given in [Procedure 2-10](#).



WARNING

- Do not wear a wrist strap while servicing the power supplies or power distribution cabling.
- Ensure that the source for the AC power is in the OFF position.
- Ensure that all of the PDU circuit breakers are OFF.

Procedure 2-10 Procedure for Task 16

1	Set the source for the AC voltage to the OFF position.
2	Ensure that the BTS ground cable (DD) is connected between the rack and the Master Ground Bar (refer to Task 3).
3	On the rear of the PSM shelf, locate the AC input terminal block cover box. Using a TORX T20 bit and driver, remove the 4 screws securing the cover box to the PSM shelf (refer to Figure 2-24).
4	Remove the cover box from the PSM shelf to expose the AC input terminal block.
5	Attach conduit to the cover box.
6	Route the AC wires and the earth ground wire through the conduit and the cover box. Leave wires extending to reach the AC input terminal block.
7	Strip 25 mm of insulation from each of the AC supply line wires and the earth ground wire.
8	Locate the ground terminal on the AC input terminal block (refer to Figure 2-23).
9	Using a flat blade screwdriver, turn the ground terminal screw counter clockwise (CCW) until the terminal is fully open. Insert the earth ground wire into the ground terminal. Turn the ground terminal screw clockwise (CW) to close the terminal and secure the wire. Tighten the terminal screw to 4.0 - 4.5 N-m (35 - 40 in-lb).
10	Determine if the AC input terminal block already has insertion bridges properly installed for the desired AC supply configuration: <ul style="list-style-type: none"> • Single-Phase • 3-Phase STAR • 3-Phase DELTA Refer to Figure 2-24 as needed.

Continued

Procedure 2-10 Procedure for Task 16 (Continued)

11	<p>Open the six line terminals as follows:</p> <ul style="list-style-type: none"> ● Insert a flat blade screwdriver into each screw hole on top of the terminal block. ● Turn the terminal screw CCW until the terminal is fully open.. <div style="display: flex; align-items: center; margin-top: 10px;">  <div style="background-color: #00b050; color: white; padding: 5px 10px; font-weight: bold; text-align: center;">NOTE</div> </div> <p style="text-align: center; margin-top: 10px;">Failure to fully open the terminals can cause improper placement of the insertion bridges in later steps.</p>
12	Place an insertion bridge into the proper terminals. While holding the bridge with one hand, turn the corresponding terminal screws CW until the bridge is securely clamped.
13	Repeat step 12 for any remaining terminals requiring an insertion bridge.
14	<p>Connect the AC supply line wires to the proper terminals as follows:</p> <ul style="list-style-type: none"> ● Insert a flat blade screwdriver into the appropriate screw hole on top of the terminal block. ● Turn the terminal screw CCW until the terminal is fully open. ● Insert the appropriate wire into the terminal. ● While holding the wire with one hand, turn the corresponding terminal screw CW until the wire is securely clamped. Tighten the terminal screw to 4.0 - 4.5 N-m (35 - 40 in-lb). <p>Refer to Figure 2-24 as needed.</p>
15	Repeat step 14 for any unconnected AC supply line wires.
16	Visually inspect all insertion bridge(s) and wires for proper placement. All conductors must be inside the clamp of each terminal block.
17	Place the cover box, with conduit attached, in position over the AC input terminal block.
18	Insert the 4 screws to secure the cover box to the PSM shelf. Ensure that the wires are not pinched.
19	Using a TORX T20 bit and driver, tighten the 4 screws to 1.6 - 1.8 N-m (14 - 16 in-lb).
20	Complete the installation of the AC wiring at the AC Power source.

Low-to-Mid Capacity Frame Expansion Procedures

Low-to-Mid Capacity Frame Expansion Overview



NOTE

The R20 UBS Macro BTS supports single band 800 MHz or 1.9 GHz RF band, up to two XMIs, up to two DMIs and one SSI. UBS Macro BTS Frame configurations with up to four XMIs and up to five DMIs will be available in the future.

This chapter provides information and procedures needed for expanding the low-capacity UBS Macro BTS starter/expansion frame to the mid-capacity frame configuration.

The mid-capacity frame consists of the low-capacity frame equipment plus the following additional expansion equipment:

- second XMI, required.
- second DMI, required.
- circuit breaker/output power connector assemblies; one required for each of the following: second XMI and second DMI.
- second set of IDRFs, required.
- optional RX splitter or RX share cable.
- third PSM, required for –48 V or 220 V AC only. Three PSMs are required for the mid capacity configuration. The third PSM is for redundancy.

Cabling of the RX splitter to the XMIs will be performed after all of the additional expansion equipment (i.e., XMI, DMI, SSI, circuit breaker/output power connector assemblies, etc.) is installed in the frame.

How to use this chapter

Typically the installer is directed to this chapter via [Task 6: Expanding the Low-capacity Frame on page 2-42 of Chapter 2 UBS Macro BTS Installation Procedure](#).

Perform all of the applicable procedures, in this chapter, for expanding the low-capacity UBS Macro BTS starter/expansion frame to the mid-capacity frame configuration.

After all of the additional expansion equipment is installed, go to [Task 7: Cabling the Optional PSM Shelf on page 2-43 of Chapter 2 UBS Macro BTS Installation Procedure](#), and continue performing the remaining tasks in sequential order.

Adding Circuit Breakers/Connectors to PDU

Objective

The objective of this section is to install additional circuit breaker/output power connector assemblies in the PDU. These additional circuit breaker/output power connector assemblies are required to allow the PDU to provide DC power to the expansion equipment being added to the UBS Macro BTS frame.

The circuit breaker/output power connector assemblies are located on the PDU front panel.

Each circuit breaker/output power connector assembly is arranged so that the circuit breaker is just below the corresponding DC output power connector.

The PDU can be equipped with the following circuit breaker/output power connector assemblies:

- up to four 90A for XMI 1 – XMI 4
- up to five 20A for DMI 1 – DMI 5
- up to two 20A for SSI 1 – SSI 2
- up to two 10A for accessory groups ACC 1 – ACC 2

The PDU in the UBS Macro BTS low-capacity starter/expansion frame is already equipped with the following circuit breaker/output power connector assemblies:

- one 90A for XMI 1
- two 20A for DMI 1 – DMI 2
- one 20A for SSI 1
- zero 10A for no accessories

The type and quantity of circuit breaker/output power connector assemblies required depends on which circuit breaker/output power connector assemblies are not already equipped in the PDU, but are needed to support the additional expansion equipment.

Required items

The following items are required:

- Appropriate type and quantity of circuit breaker/output power connector assemblies to be added for expansion purposes
 - c 90A circuit breaker/output power connector assembly (Motorola model STLN4093)
 - c 20A circuit breaker/output power connector assembly (Motorola model STLN6472)



NOTE

Mounting screws are provided with each circuit breaker/output power connector assembly; four screws with the 90A assembly and two screws with the 20A assembly.

- Side cutters; diagonal pliers or wire cutter
- Small knife
- TORX T25 bit and driver
- Torque driver

Procedure

[Procedure 3-1](#) contains the steps for adding a circuit breaker/output power connector assembly to the PDU.

Procedure 3-1 Adding a Circuit Breaker/Output Power Connector Assembly to the PDU





CAUTION

Make sure DC input power is not applied to the PDU before performing [Procedure 3-1](#).

1	Set all PDU front panel circuit breakers to the off (pulled out) position.
2	Disconnect all DC power cables from the PDU front panel. Dress these cables away from the PDU front panel.
3	Remove the PDU front panel as follows: <ul style="list-style-type: none"> • See Figure 3-1 Adding a Breaker Assembly Module to the PDU on page 3-6 photograph A. • While depressing the retaining tab on the left and right front ends of the PDU, slide the PDU front panel forward and off of the PDU.
4	Install the additional circuit breaker/output power connector assemblies in the required locations on the PDU front panel DC output power bus (see Figure 3-1 Adding a Breaker Assembly Module to the PDU on page 3-6 photograph B).

Continued

Procedure 3-1 Adding a Circuit Breaker/Output Power Connector Assembly to the PDU (Continued)

5	<p>Position the circuit breaker/output power connector assembly as follows:</p> <ul style="list-style-type: none"> • Circuit breaker actuator at the bottom and the DC output power connector at the top • Circuit breaker actuator facing toward the front of the frame • Align mounting screw holes of the circuit breaker/output power connector assembly with the corresponding screw holes on the PDU front panel DC output power bus.
6	<p>Insert the supplied mounting screws into the screw holes.</p> <div style="display: flex; align-items: center; margin-top: 10px;">  <div style="background-color: #00b050; color: white; padding: 5px 10px; font-weight: bold; text-align: center;">NOTE</div> </div> <p style="margin-top: 10px;">Two screws on top and bottom for the 90A assembly. One screw on top and bottom for the 20A assembly.</p> <p>Using a TORX T25 driver, tighten the mounting screws to 4.8 N-m (42.25 in-lb) $\pm 10\%$.</p>
7	<p>Using side cutters, cut out the applicable circuit breaker actuator and the corresponding connector covers on the PDU front panel (see Figure 3-1 Adding a Breaker Assembly Module to the PDU on page 3-6 photograph C).</p> <div style="display: flex; align-items: center; margin-top: 10px;">  <div style="background-color: #00b050; color: white; padding: 5px 10px; font-weight: bold; text-align: center;">NOTE</div> </div> <p style="margin-top: 10px;">It may be necessary to use a small knife to remove any of the tabs that do not cut cleanly.</p>
8	<p>Reattach the PDU front panel to the PDU as follows:</p> <ul style="list-style-type: none"> • See Figure 3-1 Adding a Breaker Assembly Module to the PDU on page 3-6 photograph D. • Align the PDU front panel with the PDU circuit breaker actuators and power connectors while inserting the PDU front panel retaining tabs into the retainer on the left and right front ends of the PDU. • Slide the PDU front panel onto the front of the PDU. • Firmly press on the ends of the PDU front panel until each end tab snaps into place.
9	<p>Set all PDU front panel circuit breakers to the off (pulled out) position.</p>
10	<p>Reconnect all DC power cables that were disconnected in step 2 of this procedure. Make sure that each cable is connected to the proper PDU front panel power connector.</p>

Procedural reference diagram

The following diagram helps clarify certain steps in [Procedure 3-1](#).

Figure 3-1 Adding a Breaker Assembly Module to the PDU

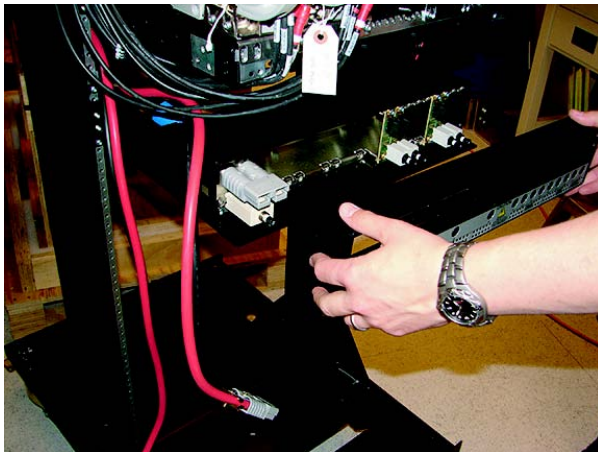

A

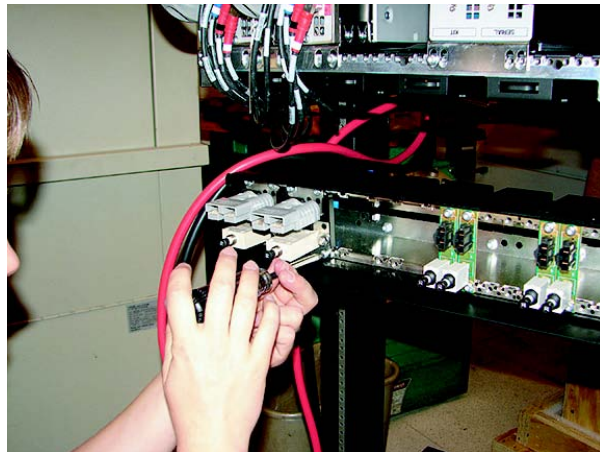

B

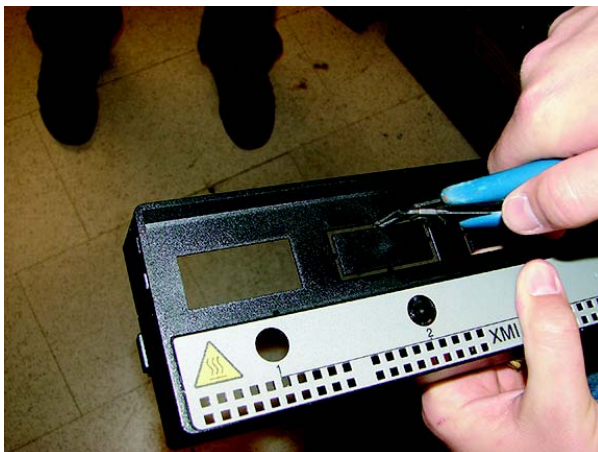

C

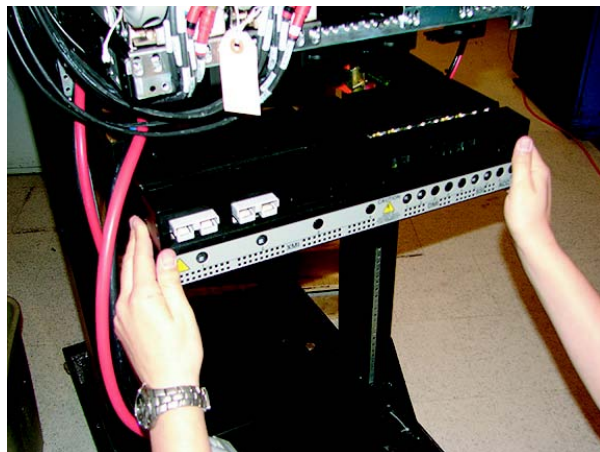

D

ti-cdma-06031.eps

Adding an XMI

Objective

The objective of this section is to mount an additional XMI into the XMI shelf.



NOTE

Cabling of the additional XMI will be performed after all of the additional expansion equipment (i.e., IDRFs, DMI, circuit breaker/output power connector assemblies, etc.) that connects to the additional XMI is installed in the frame.

Required items

Parts

The following applicable additional XMI is required:

- 800 MHz XMI assembly with removable XMI handle attached (Motorola model SGTf4194).
- 1.9 GHz XMI assembly with removable XMI handle attached (Motorola model STWG4000).

Manpower



CAUTION

The XMI module is heavy. Two people are required to lift, carry, or handle the XMI module.



NOTE

The XMI weighs 23-28 kg (50.7-61.7 lb) depending on the RF band.

Tools

The following tools are required:

- TORX T25 bit and driver
- Torque driver

Procedure

[Procedure 3-2](#) contains the steps for adding a 2nd XMI to the XMI shelf.

Procedure 3-2 Adding a 2nd XMI to the XMI Shelf

	<div data-bbox="443 793 547 885"></div> <div data-bbox="571 815 805 863">CAUTION</div> <p>The XMI module is heavy. Two people are required to lift, carry, or handle the XMI module.</p> <ul style="list-style-type: none"> • Be sure the removable XMI handle is attached to the front of the XMI before physically handling the module. • Be sure two people use both hands and wear protective footwear when handling the XMI. • Be sure to use two people to support the module while sliding the module out of or into the shelf slot.
1	Remove the XMI from its packaging and inspect it for damage.
2	<div data-bbox="443 1240 547 1332"></div> <div data-bbox="571 1261 805 1310">CAUTION</div> <p>An XMI module that is not in a shelf should always be set on its side and never on its edge. This will prevent the XMI module from tipping over and causing damage or injury.</p>
	<div data-bbox="443 1527 547 1619"></div> <div data-bbox="571 1549 805 1598">NOTE</div> <p>XMI 2 mounts in the XMI shelf slot just to the right of XMI 1. XMI 3 mounts in the XMI shelf slot just to the right of XMI 2. XMI 4 mounts in the XMI shelf slot just to the right of XMI 3.</p> <p>This step requires two people. Perform the following:</p>

Continued

Procedure 3-2 Adding a 2nd XMI to the XMI Shelf (Continued)

	<ul style="list-style-type: none">• One person grasp the XMI by the handle with both hands. The second person grasp the XMI fan tray sides with both hands. Using safe lifting technique (i.e. lift with your legs not your back), pick up the XMI and carry it over to the front of the frame.• While one person holds the XMI by the handle with both hands, the second person supports the bottom of the module with one hand and the top of the module with the other hand. Lift the XMI into the appropriate XMI shelf slot rails and gently slide it all of the way into the shelf slot.
3	Insert the four XMI mounting screws; two screws at each of the top and bottom mounting tabs on the front of the module. Using a T25 TORX driver, tighten the screws to 4.8 N-m (42.25 in-lb) $\pm 10\%$.

Procedural reference diagram

The following diagram helps clarify certain steps in [Procedure 3-2](#).

Figure 3-2 Installing a 2nd XMI

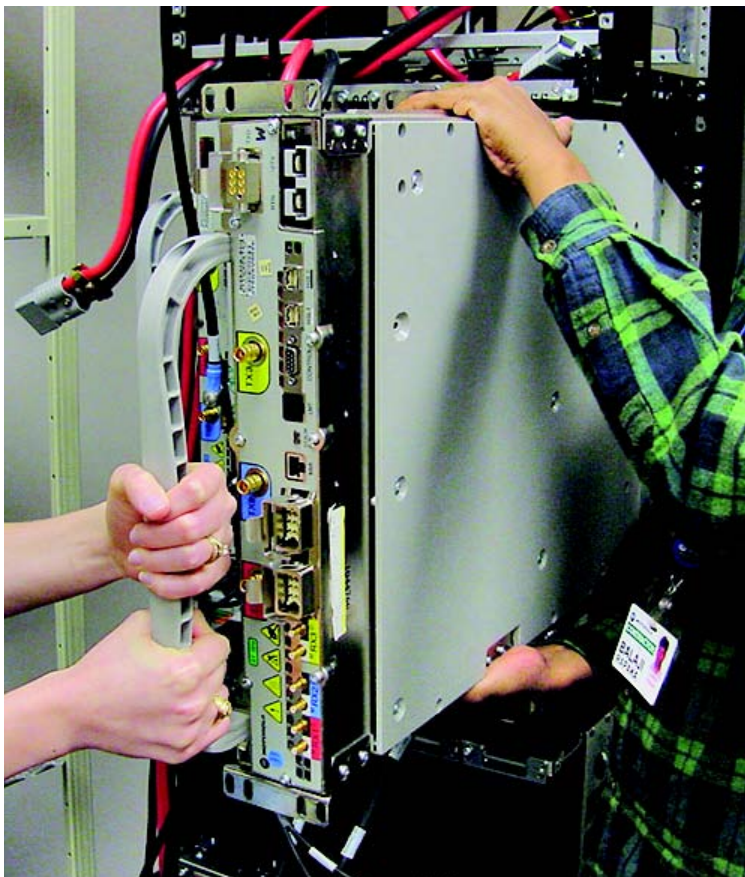

ti-cdma-06375.eps

Adding a DMI

Objective

The objective of this section is to mount an additional DMI into the XMI shelf.



NOTE

Cabling of the additional DMI will be performed after all of the additional expansion equipment (i.e., XMI, circuit breaker/output power connector assemblies, etc.) that connects to the additional DMI is installed in the frame.

Required items

Parts

The additional DMI is application dependent. Use one of the following factory built DMI assemblies as applicable:



NOTE

All models of DMI assemblies include: DMI chassis with controller board, fans and front panel.

- DMI assembly with one 1X CDMA modem board (Motorola model STLN6681).
- DMI assembly with one EV-DO modem board (Motorola model STLN6682).
- DMI assembly with two 1X CDMA modem boards (Motorola model STLN6683).
- DMI assembly with one 1X CDMA modem board and one EV-DO modem board (Motorola model STLN6684).
- DMI assembly with two EV-DO modem boards (Motorola model STLN6679).

Tools

The following tools are required:

- TORX T25 bit and driver
- Torque driver
- ESD wrist strap

Prerequisite



CAUTION

ESD handling precautions **must be** adhered to when handling the DMI assembly. Wear a conductive, high impedance wrist strap during handling.

The procedures in this chapter requires working on or around circuitry that is extremely sensitive to ESD.

Procedure

Procedure 3-3 contains the steps for adding a 2nd DMI to the XMI shelf.

Procedure 3-3 Adding a 2nd DMI to the XMI Shelf

1	Set the additional DMI assembly, in its packaging, near the UBS Macro BTS frame.
2	 <div style="display: inline-block; border: 1px solid black; background-color: yellow; padding: 2px; margin-left: 10px;">CAUTION</div> <p>ESD handling precautions must be adhered to during this procedure. Wear a conductive, high impedance wrist strap.</p> <p>Plug the end of the ESD wrist strap into the UBS Macro BTS frame ESD jack. This jack is located in the middle of the upper XMI shelf bracket. Attach the wrist strap to your wrist.</p>
3	Remove the additional DMI from its packaging and inspect it for damage.
4	<p>Install the DMI assembly into the appropriate empty DMI housing in the UBS Macro BTS frame by performing the following:</p> <ol style="list-style-type: none"> 1. Position the DMI assembly on its bottom edge so that the front panel handle is on the right and the retaining fastener is at the top.

Continued

Procedure 3-3 Adding a 2nd DMI to the XMI Shelf (Continued)

2. Pick up the DMI assembly with two hands.
 3. Insert the rear of the DMI assembly into the empty housing.
 4. Slide the DMI assembly completely into the housing (see [Figure 3-3 Installing a 2nd DMI on page 3-14](#)).
 5. Turn the retaining fastener CW (Clockwise) until finger tight to secure the DMI assembly in the housing.
-

Procedural reference diagram

The following diagram helps clarify certain steps in [Procedure 3-3](#).

Figure 3-3 Installing a 2nd DMI

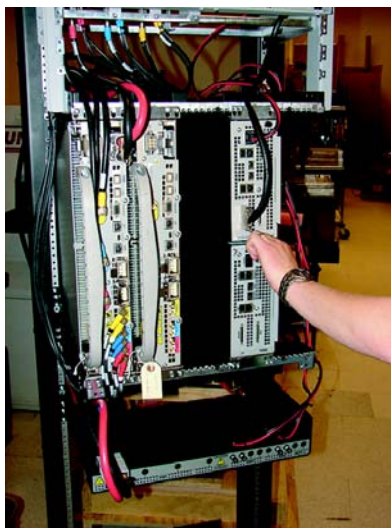

ti-cdma-06033.eps

Adding a Second Set of IDRFs

Objective

The objective of this section is to mount a second set of IDRFs into the IDRF shelf.



NOTE

Cabling of the second set of IDRFs to the second XMI will be performed after all of the additional expansion equipment (i.e., XMI, DMI, circuit breaker/output power connector assemblies, etc.) is installed in the frame.

The second set of IDRFs consists of:

- one IDRF for an omni antenna configuration.
- three IDRFs, one per sector, for a 3-sector antenna configuration.

The second set of IDRFs mounts in the right-half of the IDRF shelf. The second set of IDRFs are designated as sector 1, 2 and 3 from left to right.

Required items

Parts

The proper quantity, for omni or 3-sector antenna configuration, of the following applicable IDRF is required:

- China Full Band 800 MHz IDRF (Motorola model STF4009)
- India Full Band 800 MHz IDRF (Motorola model STF4010)
- US Full Band 800 MHz IDRF (Motorola model STF4015)
- US A-band 800 MHz IDRF (Motorola model STF4016)
- US B-band 800 MHz IDRF (Motorola model STF4017)
- 1.9 GHz IDRF (Motorola model STFG4055)

Tools

The following tools are required:

- TORX T25 bit and driver
- Torque driver

Procedure

[Procedure 3-4](#) contains the steps for adding a second set of IDRFs to the IDRF shelf.

Procedure 3-4 Adding a second set of IDRFs to the IDRF shelf

1	Remove the additional IDRFs from their packaging and inspect them for damage.
2	<p>While working at the front/top of the UBS Macro BTS frame, pick up an additional IDRF and mount it into the IDRF shelf as follows:</p> <ul style="list-style-type: none"> • Position the IDRF with the IDRF mounting plate on top/facing upward and the mounting plate flange is on the right side (see Figure 3-4 Installing the second set of IDRFs on page 3-17 photograph B). • Insert the first IDRF into the sector 1 position on the right half of the top of the IDRF shelf (see photograph A). • Slide the IDRF down into the IDRF shelf.
3	Repeat step 2 for the remaining IDRFs, but insert them in sector 2 and sector 3 positions.
4	Insert four mounting screws through each IDRF mounting plate and into the IDRF shelf. Using a T25 TORX driver, tighten the mounting screws for all of the additional IDRFs to 4.8 N-m (42.25 in-lb) $\pm 10\%$.

Procedural reference diagram

The following diagram helps clarify certain steps in [Procedure 3-4](#).

Figure 3-4 Installing the second set of IDRFs



A

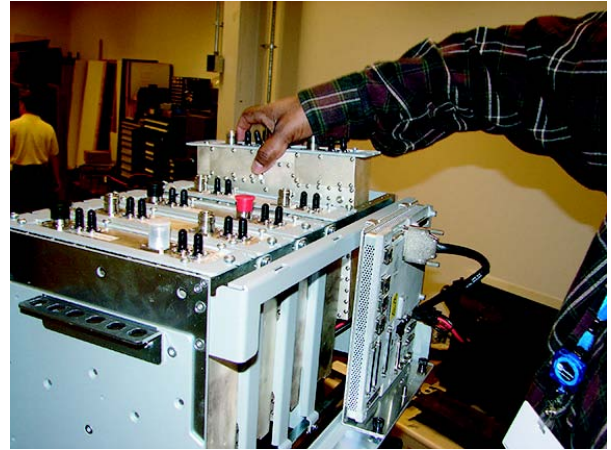

B

ti-cdma-06035.eps

Adding an Optional RX Splitter

Objective

The objective of this section is to mount the optional RX splitter onto the bottom of the XMI shelf.



NOTE

Cabling of the RX splitter to the XMIs will be performed after all of the additional expansion equipment (i.e., XMI, DMI, circuit breaker/output power connector assemblies, etc.) is installed in the frame.

Required items

Parts

The following part is required:

- Wide band (800 MHz through 2.1 GHz RF bands) RX splitter (Motorola model STRG4029)

Tools

The following tools are required:

- TORX T25 bit and driver
- Torque driver

Procedure

[Procedure 3-5](#) contains the steps for adding the RX splitter to the bottom of the XMI shelf.

Procedure 3-5 Adding an RX splitter to the XMI shelf

1	Remove the RX splitter from its packaging and inspect it for damage.
2	While working at the front of the UBS Macro BTS frame, pick up the RX splitter and mount it onto the bottom of the XMI shelf as follows:

Continued

Procedure 3-5 Adding an RX splitter to the XMI shelf (Continued)

- See [Figure 3-5 Mounting the RX splitter on page 3-19](#).
- Position the RX splitter as follows:
 - RX splitter I/O connectors facing toward front of the frame.
 - RX splitter mounting tabs, one on each end of splitter, facing up.
 - In front of the XMI shelf bottom bracket.
- Align the guide pins on each RX splitter mounting tab with the corresponding hole located on the XMI shelf bottom bracket (see photograph **A**).
- Insert the guide pins into the holes and hold the RX splitter mounting tabs against the XMI shelf bottom bracket.
- Insert a mounting screw through each RX splitter mounting tab and into the XMI shelf bottom bracket. (see photograph **B**).

3 Using a T25 TORX driver, tighten the mounting screws to 4.8 N-m (42.25 in-lb) $\pm 10\%$.

Procedural reference diagram

The following diagram helps clarify certain steps in [Procedure 3-5](#).

Figure 3-5 Mounting the RX splitter

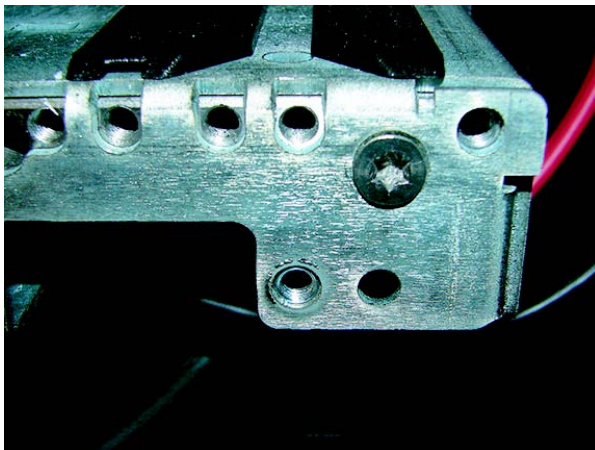

A



B

ti-cdma-06036.eps

Adding a third PSM (-48 V or 220 V AC only)



NOTE

A third PSM is required when expanding a -48 V DC or 220 VAC UBS Macro BTS frame from low capacity to mid capacity. The third PSM is for redundancy.

Objective

For -48 V or 220 V AC only, install the appropriate PSM into slot 3 of the PSM shelf. If applicable, remove the filler plate that covers slot 3 of the PSM shelf and then install the appropriate PSM into slot 3.

Required items

Parts



CAUTION

Never plug a -48 V DC PSM into a 220 V AC PSM shelf.
Never plug a 220 V AC PSM into a -48 V DC PSM shelf.

One of either the following parts is required:

- -48 V DC Power Supply Module (-48 V DC PSM) — Motorola model STPN4037
- 220 V AC Power Supply Module (220 V AC PSM) — Motorola model STPN4036

Tools

The following tools are required:

- TORX T25 bit and driver
- Torque driver

Procedure

Procedure 3-6 contains the steps for adding a third PSM to the PSM shelf.

Procedure 3-6 Adding a 3rd PSM to the PSM shelf

1	Use a T25 TORX bit and driver to completely loosen the captive retaining thumbscrew on the filler plate that covers slot 3 of the PSM shelf. Remove the filler plate.
2	<div data-bbox="480 619 587 715"></div> <div data-bbox="612 646 850 697">WARNING</div> <p data-bbox="608 729 1437 789">PSM weighs approximately 5 kg. Be careful when handling the PSM to prevent damage to the equipment and personal injury.</p> <p data-bbox="480 815 1254 844">Install the appropriate PSM into PSM shelf slot 3 as follows:</p> <ol data-bbox="480 900 1398 1129" style="list-style-type: none">1. Grasp the handle on the front panel of the PSM with one hand while carefully supporting the bottom of the module with the other hand.2. Properly orient the PSM and insert it into the slot.3. Slowly slide the module into the shelf until the rear connectors are fully seated. Make sure that the PSM is fully engaged with the shelf backplane slot connectors.
3	Using a T25 TORX bit and torque driver, tighten the captive retaining thumbscrew to 2.37 N-m (21 in-lb).

Mid-capacity Expansion Interconnect Cabling



NOTE

Remember – After all of the additional expansion equipment is installed and cabled, you **must** go to [Task 7: Cabling the Optional PSM Shelf on page 2-43 of Chapter 2 UBS Macro BTS Installation Procedure](#), and continue performing the remaining installation tasks in sequential order.

Objective

The objective of this section is to route and connect all required cabling between the additional mid-capacity expansion equipment (i.e., 2nd XMI, 2nd DMI, optional RX splitter, circuit breaker/output power connector assemblies) that is installed in the frame.



NOTE

The RX splitter is optional equipment for expansion to mid-capacity. An RX share cable can be used instead of the RX splitter for interconnecting RX RF signals between XMI 1 and XMI 2.

Installing DC power cables

Locate the required DC power cables and then perform [Procedure 3-7](#) through [Procedure 3-8](#) as needed.

Required DC power cables

- XMI DC power cable (Motorola part number 3088319T03)
- DMI DC power cable (Motorola part number 3088961T05)

DC power cabling procedures

Procedure 3-7 Installing the XMI 2 DC power cable

1	Locate the XMI DC power cable (Motorola part number 3088319T03).
2	Connect the appropriate end of the XMI DC power cable to the +27 V DC input power connector on the top of XMI 2 front panel.

Continued

Procedure 3-7 Installing the XMI 2 DC power cable (Continued)

3	<p>Route the loose end of the XMI DC power cable as follows:</p> <ol style="list-style-type: none"> 1. Through the opening above XMI 2 between the XMI shelf and the IDR shelf to the back of the XMI shelf. 2. Down and around the left side of the rear of XMI 2. <div style="display: flex; align-items: center; margin: 10px 0;">  <div style="background-color: #00ffff; padding: 5px; margin-left: 10px; font-weight: bold; color: white;">NOTE</div> </div> <p style="text-align: center; margin: 0 0 10px 0;">To avoid blocking exhaust air from the XMI, the XMI DC power cable must not be routed directly behind the XMI.</p> <ol style="list-style-type: none"> 3. Down to the PDU and over the top of the PDU to the PDU front panel.
4	<p>Connect the loose end of the XMI DC power cable to the XMI 2 DC output power connector on the PDU front panel.</p>

Procedure 3-8 Installing the DMI 2 DC power cable

1	Locate the DMI DC power cable (Motorola part number 3088961T05).
2	Connect the appropriate end of the DMI DC power cable to the DMI 2 DC output power connector on the PDU front panel.

Continued

Procedure 3-8 Installing the DMI 2 DC power cable (Continued)

- 3** Route the loose end of the DMI DC power cable as follows:
- 1.** Up the right side of the frame/rack and around to the back of the frame.
 - 2.** Through the opening between the XMI shelf and the IDRf shelf and over the XMI shelf top bracket.
 - 3.** Down to the front panel of the appropriate DMI.

**NOTE**

Excess cable should be coiled up and placed on top of the XMI shelf top bracket.

- 4** Connect the loose end of the DMI DC power cable to the +27 V DC input power connector on the front panel of DMI 2.

Installing/Connecting RF cables (XMI to IDRf)

Locate the required RF cables and then perform [Procedure 3-9](#) and [Procedure 3-10](#) as needed.

Required RF cables

The required TX RF cables are as follows:

- TX sector-1 RF cable (Motorola part number 3088160T73)
- TX sector-2 RF cable (Motorola part number 3088160T74)
- TX sector-3 RF cable (Motorola part number 3088160T75)

RF cabling procedures

Perform [Procedure 3-9](#) to install the TX RF cables between XMI 2 and the second set of IDRFs.

Procedure 3-9 Installing TX RF cables

1	<p>Locate the following TX RF cables:</p> <ul style="list-style-type: none"> • TX sector-1 RF cable (Motorola part number 3088160T73) • TX sector-2 RF cable (Motorola part number 3088160T74) • TX sector-3 RF cable (Motorola part number 3088160T75)
2	<p>Install the TX sector-1 RF cable as follows:</p> <ol style="list-style-type: none"> 1. Connect one end of the cable to the TX1 connector on the XMI 2 front panel. 2. Route the loose end of the cable through the opening between the XMI shelf and the IDRF shelf. 3. Loop the cable around under the second set of IDRFs. 4. Connect the loose end of the TX sector-1 RF cable to the TX input connector on the bottom panel of the sector-1 IDRF of the second set of IDRFs.
3	<p>Install the TX sector-2 RF cable as follows:</p> <ol style="list-style-type: none"> 1. Connect one end of the cable to the TX2 connector on the XMI 2 front panel. 2. Route the loose end of the cable through the opening between the XMI shelf and the IDRF shelf. 3. Loop the cable around under the second set of IDRFs. 4. Connect the loose end of the TX sector-2 RF cable to the TX input connector on the bottom panel of the sector-2 IDRF of the second set of IDRFs.
4	<p>Install the TX sector-3 RF cable as follows:</p> <ol style="list-style-type: none"> 1. Connect one end of the cable to the TX3 connector on the XMI 2 front panel. 2. Route the loose end of the cable through the opening between the XMI shelf and the IDRF shelf. 3. Loop the cable around under the second set of IDRFs. 4. Connect the loose end of the TX sector-3 RF cable to the TX input connector on the bottom panel of the sector-3 IDRF of the second set of IDRFs.

Perform [Procedure 3-10](#) to connect the RX RF cables between XMI 2 and the second set of IDRFs.

Procedure 3-10 Connecting RX RF cables

	 <div style="background-color: #00FFFF; padding: 5px; display: inline-block; margin-left: 10px;">NOTE</div> <p>On frames with more than one XMI, the XMIs have unused RX input ports. These unused RX inputs ports must not be terminated. Terminating these unused RX inputs ports will cause improper operation of the XMIs.</p>
1	<p>Disconnect the following RX RF cables from the front panel of XMI 1:</p> <ol style="list-style-type: none"> 1. Disconnect the end of the 3088160T79 cable from the RX1 D connector on the XMI 1 front panel. 2. Disconnect the end of the 3088160T80 cable from the RX2 D connector on the XMI 1 front panel. 3. Disconnect the end of the 3088160T81 cable from the RX3 D connector on the XMI 1 front panel.
2	<p>Connect the RX RF cables that were disconnected in step 1 to the front panel of XMI 2 as follows:</p> <ol style="list-style-type: none"> 1. Connect the loose end of the 3088160T79 cable to the RX1 D connector on the XMI 2 front panel. 2. Connect the loose end of the 3088160T80 cable to the RX2 D connector on the XMI 2 front panel. 3. Connect the loose end of the 3088160T81 cable to the RX3 D connector on the XMI 2 front panel.
3	<p>Disconnect the following RX RF cables from the bottom of the first (original) set of IDRFs as follows:</p> <ol style="list-style-type: none"> 1. Disconnect the end of the 3088160T79 cable from the RX DIV connector on the bottom panel of the sector-1 IDRf of the first set of IDRfs. 2. Disconnect the end of the 3088160T80 cable from the RX DIV connector on the bottom panel of the sector-2 IDRf of the first set of IDRfs. 3. Disconnect the end of the 3088160T81 cable from the RX DIV connector on the bottom panel of the sector-3 IDRf of the first set of IDRfs.

Continued

Procedure 3-10 Connecting RX RF cables (Continued)

- | | |
|----------|--|
| 4 | <p>Connect the RX RF cables that were disconnected in step 3 to the bottom panel of the second set of IDRFs as follows:</p> <ol style="list-style-type: none"> 1. Connect the loose end of the 3088160T79 cable to the RX MAIN connector on the bottom panel of the sector-1 IDRF of the second set of IDRFs. 2. Connect the loose end of the 3088160T80 cable to the RX MAIN connector on the bottom panel of the sector-2 IDRF of the second set of IDRFs. 3. Connect the loose end of the 3088160T81 cable to the RX MAIN connector on the bottom panel of the sector-3 IDRF of the second set of IDRFs. |
|----------|--|

Installing XMI to DMI cables

Locate the required XMI to DMI cables and then perform [Procedure 3-11](#).

**NOTE**

For the mid-capacity frame, there are four 3088791T02 cables used to interconnect XMIs to DMIs. One of these cables is already installed/connected in the low-capacity configuration.

Required XMI to DMI cables

The required XMI to DMI cables are as follows:

- Three XMI to DMI cables (Motorola part number 3088791T02)

XMI to DMI cabling procedure

Perform [Procedure 3-11](#) to install the XMI to DMI cables between two XMIs and two DMIs.

Procedure 3-11 Installing XMI to DMI cables

- | | |
|----------|---|
| 1 | Verify that an XMI to DMI cable (Motorola part number 3088791T02) is already installed/connected between XMI 1 front panel connector HSL 1 and DMI 1 front panel connector XMI 1/BSI. |
| 2 | <p>Locate the following cables:</p> <ul style="list-style-type: none"> • Three XMI to DMI cables (Motorola part number 3088791T02) |

Continued

Procedure 3-11 Installing XMI to DMI cables (Continued)

3	<p>Install an XMI to DMI cable between XMI 1 and DMI 2 as follows:</p> <ol style="list-style-type: none"> 1. Connect the appropriate end of the 3088791T02 cable to the HSL 2 connector on the XMI 1 front panel. 2. Route the loose end of the cable up above XMI 1, through the opening between the XMI shelf and IDRF shelf, and behind the hooks on the top XMI shelf bracket. Continue routing over to the XMI shelf DMI slot and then down to DMI 2. 3. Connect the loose end of the 3088791T02 cable to the XMI 1/BSI connector on the DMI 2 front panel.
4	<p>Install an XMI to DMI cable between XMI 2 and DMI 1 as follows:</p> <ol style="list-style-type: none"> 1. Connect the appropriate end of the 3088791T02 cable to the HSL 1 connector on the XMI 2 front panel. 2. Route the loose end of the cable up above XMI 2 through the opening between the XMI shelf and IDRF shelf, and behind the hooks on the top XMI shelf bracket. Continue routing over to the XMI shelf DMI slot and then down to DMI 1. 3. Connect the loose end of the 3088791T02 cable to the XMI 2 connector on the DMI 1 front panel.
5	<p>Install an XMI to DMI cable between XMI 2 and DMI 2 as follows:</p> <ol style="list-style-type: none"> 1. Connect the appropriate end of the 3088791T02 cable to the HSL 2 connector on the XMI 2 front panel. 2. Route the loose end of the cable up above XMI 2 through the opening between the XMI shelf and IDRF shelf, and behind the hooks on the top XMI shelf bracket. Continue routing over to the XMI shelf DMI slot and then down to DMI 2. 3. Connect the loose end of the 3088791T02 cable to the XMI 2 connector on the DMI 2 front panel.

Installing DMI to SSI cables

Locate the required DMI to SSI cables and then perform [Procedure 3-12](#).

**NOTE**

For the mid-capacity frame, there are two 3088792T01 cables used to interconnect SSI 1 to DMI 1 and DMI 2. One of these cables is already installed/connected in the low-capacity configuration.

Required DMI to SSI cables

The required DMI to SSI cable is as follows:

- One DMI to SSI cable (Motorola part number 3088792T01)

DMI to SSI cabling procedure

Perform [Procedure 3-12](#) to install the DMI to SSI cable between SSI 1 and DMI 2.

Procedure 3-12 Installing DMI 2 to SSI 1 cable

1	Verify that a DMI to SSI cable (Motorola part number 3088792T01) is already installed/connected between DMI 1 front panel connector IDI/SSI 1 and SSI 1 front panel connector DMI 1/IDI .
2	Locate the following cables: <ul style="list-style-type: none"> • One DMI to SSI cable (Motorola part number 3088792T01)
3	Install the DMI to SSI cable between DMI 2 and SSI 1 as follows: <ol style="list-style-type: none"> 1. Connect the appropriate end of the 3088792T01 cable to the IDI/SSI 1 connector on the DMI 2 front panel. 2. Route the loose end of the cable up above the XMI shelf DMI slot, through the opening between the XMI shelf and the IDRf shelf, and out the right side of the opening. Continue routing upwards along the right rack rail and over in to SSI 1. <div style="margin-top: 10px;">  <div style="background-color: #00ffff; padding: 5px; display: inline-block; margin-left: 10px;">NOTE</div> <p style="margin-left: 20px;">Excess cable should be coiled up and placed on top of the XMI shelf top bracket.</p> </div> <ol style="list-style-type: none"> 3. Connect the loose end of the 3088792T01 cable to the DMI 2 connector on the SSI 1 front panel.

Installing RX splitter to XMI RX RF cables or RX share cable

Expansion to mid-capacity requires interconnection of RX RF signals between XMI 1 and XMI 2. This can be accomplished by using an optional RX splitter or RX share cable.

If the optional RX splitter is used, locate the required RX splitter to XMI RX RF cables and then perform [Procedure 3-13](#).

If the optional RX splitter is not used, locate the required RX share cable and then perform [Procedure 3-14](#).

Required RX splitter to XMI RX RF cables

The required RX splitter to XMI RX RF cables are as follows:

- RX splitter to XMI 1 RX RF cable (Motorola part number 3088407T10)
- RX splitter to XMI 2 RX RF cable (Motorola part number 3088407T11)

Required RX share cable

The required RX share cable is as follows:

- RX share cable (Motorola part number SGLN6345 which includes: 3088407T09 cable)



NOTE

The RX share cable connects XMI 1 **RX EXP OUT** to XMI 2 **RX EXP IN** and XMI 2 **RX EXP OUT** to XMI 1 **RX EXP IN**.

RX splitter to XMI cabling procedure

Perform [Procedure 3-13](#) to install the RX splitter to XMI RX RF cables between RX splitter and the two XMIs.

Procedure 3-13 Installing RX splitter to XMI RX RF cables

1	<p>Locate the following cables:</p> <ul style="list-style-type: none"> • RX splitter to XMI 1 RX RF cable (Motorola part number 3088407T10) • RX splitter to XMI 2 RX RF cable (Motorola part number 3088407T11)
2	<p>Install the RX splitter to XMI 1 RX RF cable (Motorola part number 3088407T10) as follows:</p> <div style="margin-top: 10px;">  <div style="background-color: #00e0e0; color: white; padding: 5px; display: inline-block;">NOTE</div> </div> <p>The 3088407T10 cable contains two separate cables bundled together. The 3088407T10 cable has two connectors on each end of the bundle. The ends of each separate cable can be determined by observation.</p> <ol style="list-style-type: none"> 1. Position the 3088407T10 cable so that two connectors on one end of the bundle are in front of XMI 1 (i.e., XMI end) and the two connectors on the other end of the bundle are in front of the RX splitter.

Continued

Procedure 3-13 Installing RX splitter to XMI RX RF cables (Continued)

2. Connect an XMI end connector to the **RX EXP OUT** connector on the XMI 1 front panel.
3. Connect the loose end of the same separate cable to the **XMI 1 RX EXP IN** connector on the RX splitter front panel.
4. Connect the remaining XMI end connector to the **RX EXP IN** connector on the XMI 1 front panel.
5. Connect the loose end of the same separate cable to the **XMI 1 RX EXP OUT** connector on the RX splitter front panel.

- 3 Install the RX splitter to XMI 2 RX RF cable (Motorola part number 3088407T11) as follows:

**NOTE**

The 3088407T11 cable contains two separate cables bundled together. The 3088407T11 cable has two connectors on each end of the bundle. The ends of each separate cable can be determined by observation.

1. Position the 3088407T11 cable so that two connectors on one end of the bundle are in front of XMI 2 (i.e., XMI end) and the two connectors on the other end of the bundle are in front of the RX splitter.
2. Connect an XMI end connector to the **RX EXP OUT** connector on the XMI 2 front panel.
3. Connect the loose end of the same separate cable to the **XMI 2 RX EXP IN** connector on the RX splitter front panel.
4. Connect the remaining XMI end connector cable to the **RX EXP OUT** connector on the XMI 2 front panel.
5. Connect the loose end of the same separate cable to the **XMI 2 RX EXP IN** connector on the RX splitter front panel.

XMI 1 to XMI 2 RX cabling procedure

Perform [Procedure 3-14](#) to install the RX share cable to interconnect RX RF signals between XMI 1 and XMI 2.

Procedure 3-14 Installing RX share cable**Continued**

Procedure 3-14 Installing RX share cable (Continued)

1

Locate the following cable:

- RX share cable (Motorola part number SGLN6345 which includes: 3088407T09 cable)

**NOTE**

The 3088407T09 cable contains two separate cables bundled together. The 3088407T09 cable has four ends with a connector on each end.

The ends of the RX share cable are labeled as follows:

- **XMI 1 OUT**
- **XMI 1 IN**
- **XMI 2 OUT**
- **XMI 2 IN**

2

Install the RX share cable as follows:

1. Connect the **XMI 1 OUT** cable connector to the **RX EXP OUT** connector on the XMI 1 front panel.
2. Connect the **XMI 1 IN** cable connector to the **RX EXP IN** connector on the XMI 1 front panel.
3. Connect the **XMI 2 OUT** cable connector to the **RX EXP OUT** connector on the XMI 2 front panel.
4. Connect the remaining **XMI 2 IN** cable connector to the **RX EXP IN** connector on the XMI 2 front panel.

3

**NOTE**

Because it is possible to incorrectly connect the the RX share cable between XMI 1 and XMI 2, it is necessary to verify these connections.

Verify that the RX share cable is properly connected between XMI 1 and XMI 2 as follows:

- The cable ends labeled **XMI 1 OUT** and **XMI 1 IN** must be connected to XMI 1.
- The cable ends labeled **XMI 2 OUT** and **XMI 2 IN** must be connected to XMI 2.

Continued

Procedure 3-14 Installing RX share cable (Continued)

- The cable ends with the word **OUT** in its label must be connected to XMI connectors labeled **RX EXP OUT**.
 - The cable ends with the word **IN** in its label must be connected to XMI connectors labeled **RX EXP IN**.
-

What's Next

Installation completion

At this point the hardware installation is complete. Perform the following tasks to complete the system installation.

- Clean up the site
- Fill out the installation completion checklist
- Record **As-Built** information
- Perform the ATPs
- Load the software

Perform the clean up of the site and fill out the checklist, first. Then perform the rest of the tasks or perform them later.

Clean up the site

Clean up the site by following the instructions given in [Procedure 4-1](#).

Procedure 4-1 Cleaning the site

1	Remove protective covering Remove any cardboard from the walls that was used to protect the walls. Remove any antistatic plastic or cloth sheet used to cover the equipment.
2	Lighting fixtures Remove any masking tape from the fluorescent light fixtures.
3	Tools Place all hand and power tools in the installation tool kit or other appropriate place. Check for any tools requiring replacement, cleaning, or adjustment.
4	Materials Place any leftover materials in a location specified by the site manager.
5	Remove debris To remove the debris, perform the following: <ul style="list-style-type: none"> • Remove any packing material. • Ensure that all scrap materials are removed from any tables or stands. • Clean/sweep the floor. Ensure all chalk-line marks are removed.

Continued

Procedure 4-1 Cleaning the site (Continued)

6	<p>Environment Perform the following to check the environment:</p> <ul style="list-style-type: none"> • Check whether all covers, frame doors and fan housings are in place. • Confirm all power connections are tight. • Organize any items (such as manuals, materials, etc.) left on site and place them in a safe location specified by the site manager.
----------	---

Fill out the installation completion checklist

After the site is cleaned up, fill out the installation completion checklist and make any necessary copies. Copy this check sheet as required.

Installation completion checklist

Date Hardware Installation Completed: _____

Site: _____

BTS Frame Serial Number: _____

Checklist Completed By: _____

Checklist Reviewed By: _____

Table 4-1 Installation completion checklist

Status	No.	Item	Notes
	1	Frames are bolted down.	
	2	DC power cabling completed.	
	3	Each frame has its own earth ground.	
	4	RX RF cables installed.	
	5	TX RF cables installed.	
	6	Span line cables installed.	
	7	Alarm cables installed.	
	8	RGPS head installed (if required).	
	9	RGPS cabling installed (if required).	
	10	All connectors (power, signal, RF, internal and external) are tight.	
	11	All cables dressed and tied.	
	12	Installation and site specific manuals at site.	

Continued

Table 4-1 Installation completion checklist (Continued)

Status	No.	Item	Notes
	13	Cable racks properly grounded.	
	14	Static wrist straps are present.	
	15	Site cleaned, swept, and trash removed.	
	16	Any deficiencies reported to the appropriate people.	
	17	Correct polarity has been maintained from the DC power source to the frame.	
	18	Power has not been applied to any frame.	

Record "As-Built" information

Record the site specific information on how the unit was installed and cabled.

Performing the ATPs

This manual does not cover the procedure of performing the ATPs. For this procedure, refer to the *1X UBS Macro BTS Optimization/ATP* (68P09283A63) manual.

Loading the software

This manual does not cover the procedure for loading the software. Refer to the appropriate software release manual for procedure for loading the software.