

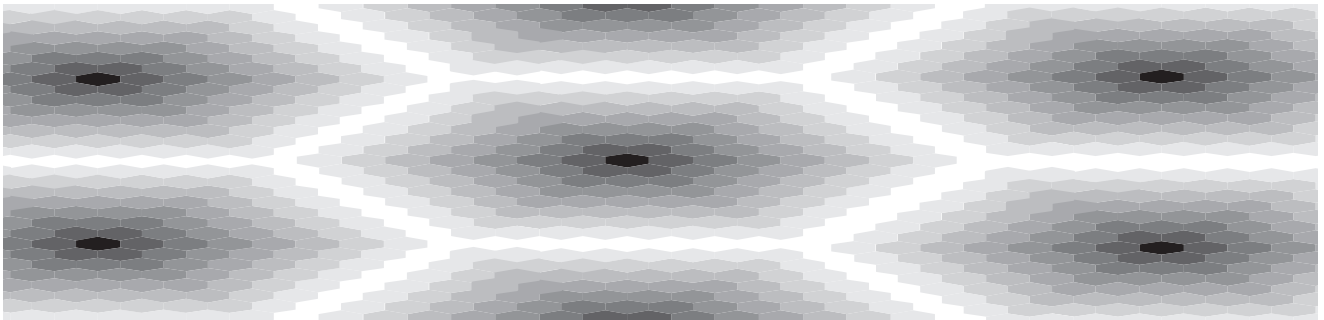

# **SC™ 4812ETL BTS Optimization/ATP**

---

Release 2.15.x.x and CDMA LMF Build 2.15.x.x



**CDMA 800MHz and 1.9GHz**

English  
08/15/2000  
68P09250A99-1

**PRELIMINARY**

## Notice

While reasonable efforts have been made to assure the accuracy of this document, Motorola, Inc. assumes no liability resulting from any inaccuracies or omissions in this document, or from use of the information obtained herein. The information in this document has been carefully checked and is believed to be entirely reliable. However, no responsibility is assumed for inaccuracies or omissions. Motorola, Inc. reserves the right to make changes to any products described herein and reserves the right to revise this document and to make changes from time to time in content hereof with no obligation to notify any person of revisions or changes. Motorola, Inc. does not assume any liability arising out of the application or use of any product, software, or circuit described herein; neither does it convey license under its patent rights or the rights of others.

It is possible that this publication may contain references to, or information about Motorola products (machines and programs), programming, or services that are not announced in your country. Such references or information must not be construed to mean that Motorola intends to announce such Motorola products, programming, or services in your country.

## Copyrights

This instruction manual, and the Motorola products described in this instruction manual may be, include or describe copyrighted Motorola material, such as computer programs stored in semiconductor memories or other media. Laws in the United States and other countries preserve for Motorola certain exclusive rights for copyrighted material, including the exclusive right to copy, reproduce in any form, distribute and make derivative works of the copyrighted material. Accordingly, any copyrighted Motorola material contained herein or in the Motorola products described in this instruction manual may not be copied, reproduced, distributed, merged or modified in any manner without the express written permission of Motorola. Furthermore, the purchase of Motorola products shall not be deemed to grant either directly or by implication, estoppel, or otherwise, any license under the copyrights, patents or patent applications of Motorola, as arises by operation of law in the sale of a product.

## Usage and Disclosure Restrictions

### License Agreement

The software described in this document is the property of Motorola, Inc. It is furnished by express license agreement only and may be used only in accordance with the terms of such an agreement.

### Copyrighted Materials

Software and documentation are copyrighted materials. Making unauthorized copies is prohibited by law. No part of the software or documentation may be reproduced, transmitted, transcribed, stored in a retrieval system, or translated into any language or computer language, in any form or by any means, without prior written permission of Motorola, Inc.

### High Risk Activities

Components, units, or third-party products used in the product described herein are NOT fault-tolerant and are NOT designed, manufactured, or intended for use as on-line control equipment in the following hazardous environments requiring fail-safe controls: the operation of Nuclear Facilities, Aircraft Navigation or Aircraft Communication Systems, Air Traffic Control, Life Support, or Weapons Systems ("High Risk Activities"). Motorola and its supplier(s) specifically disclaim any expressed or implied warranty of fitness for such High Risk Activities.

## Trademarks



and Motorola are registered trademarks of Motorola, Inc.

Product and service names profiled herein are trademarks of Motorola, Inc. Other manufacturers' products or services profiled herein may be referred to by trademarks of their respective companies.

## Copyright

© Copyright 2000 Motorola, Inc.  
All Rights Reserved



Printed on  
Recyclable Paper

REV010600

*SPECIFICATIONS SUBJECT TO CHANGE WITHOUT NOTICE*

# PRELIMINARY



## Table of Contents

### SC 4812ETL BTS Optimization/ATP

Release 2.15.x.x and CDMA LMF Build 2.15.x.x

List of Figures .....	iv
List of Tables .....	vi
Product Information .....	xi
Foreword .....	xii
General Safety .....	xv
Revision History .....	xvii
Patent Notification .....	xviii

#### Chapter 1: Introduction

Optimization Manual Scope and Layout .....	1-1
Purpose of the Optimization .....	1-3
When to Optimize .....	1-4
Required Test Equipment and Software .....	1-5
Required Documents and Related Publications .....	1-12
Terms and Abbreviations .....	1-13
BTS Equipment Identification .....	1-14
Cabinet Identification .....	1-16
Internal Assembly Location and Identification .....	1-17
BTS Sector Configurations .....	1-22

#### Chapter 2: Preliminary Operations

Preliminary Operations: Overview .....	2-1
Initial Power Up .....	2-3

#### Chapter 3: Optimization/Calibration

Optimization/Calibration – Introduction .....	3-1
Isolate Span Lines/Connect LMF .....	3-4
Preparing the LMF .....	3-10
LMF to BTS Connection .....	3-20
Using CDMA LMF .....	3-21
Pinging the Processors .....	3-28

---

## Table of Contents – continued

Download the BTS .....	3-30
CSM System Time – GPS & LFR/HSO Verification .....	3-37
Test Equipment Setup .....	3-47
Test Set Calibration .....	3-55
Bay Level Offset Calibration .....	3-64
RFDS Setup and Calibration .....	3-76
Alarms Testing .....	3-85

### Chapter 4: Automated Acceptance Test Procedure (ATP)

Automated Acceptance Test Procedure – Introduction .....	4-1
Acceptance Tests – Test Set Up .....	4-3
Abbreviated (All-inclusive) Acceptance Tests .....	4-4
Individual Acceptance Tests–Introduction .....	4-7
TX Spectral Purity Transmit Mask Acceptance Test .....	4-9
TX Waveform Quality (Rho) Acceptance Test .....	4-12
TX Pilot Time Offset Acceptance Test .....	4-13
TX Code Domain Power/Noise Floor Acceptance Test .....	4-15
RX FER Acceptance Test .....	4-18
Generating an ATP Report .....	4-20

### Chapter 5: Leaving the Site

Updating Calibration Data Files .....	5-1
Prepare to Leave the Site .....	5-3

### Chapter 6: Basic Troubleshooting

Basic Troubleshooting Overview .....	6-1
Troubleshooting: Installation .....	6-2
Troubleshooting: Download .....	6-4
Troubleshooting: Calibration .....	6-7
Troubleshooting: Transmit ATP .....	6-9
Troubleshooting: Receive ATP .....	6-11
Troubleshooting: CSM Checklist .....	6-12
SCCP Backplane Troubleshooting .....	6-14
RFDS – Fault Isolation .....	6-20
Module Front Panel LED Indicators and Connectors .....	6-22
Basic Troubleshooting – Span Control Link .....	6-29

### Appendix A: Data Sheets

Appendix A: Optimization (Pre-ATP) Data Sheets .....	A-1
--	-----

---

## Table of Contents – continued

Appendix A: Site Serial Number Check List .....	A-13
<b>Appendix B: FRU Optimization/ATP Test Matrix</b>	
Appendix B: FRU Optimization/ATP Test Matrix .....	B-1
<b>Appendix C: BBX Gain Set Point vs. BTS Output Considerations</b>	
Appendix C: BBX2 Gain Set Point vs. BTS Output Considerations .....	C-1
<b>Appendix D: CDMA Operating Frequency Information</b>	
CDMA Operating Frequency Programming Information – North American PCS Bands . D-1	
<b>Appendix E: PN Offset/I &amp; Q Offset Register Programming Information</b>	
Appendix E: PN Offset Programming Information .....	E-1
<b>Appendix F: Test Equipment Preparation</b>	
Test Equipment Preparation .....	F-1
Manual Cable Calibration .....	F-10
<b>Appendix G: Download ROM Code</b>	
Downloading ROM Code with the LMF .....	G-1
<b>Index</b>	



## List of Figures

### SC 4812ETL BTS Optimization/ATP

Release 2.15.x.x and CDMA LMF Build 2.15.x.x

Figure 1-1: Typical Logical BTS Configurations .....	1-15
Figure 1-2: SC4812ETL Cabinet .....	1-16
Figure 1-3: Internal Assemblies and FRUs (Cabinet doors not shown for clarity) .....	1-17
Figure 1-4: SCCP Shelf .....	1-19
Figure 1-5: RF Interface Panel .....	1-21
Figure 1-6: RFDS and DRDC Details .....	1-21
Figure 1-7: SC4812ETL LPA Configuration with Combiners/Filters .....	1-24
Figure 2-1: Backplane DIP Switch Settings .....	2-2
Figure 2-2: AC Load Center External Power Connections .....	2-5
Figure 2-3: Cabinet Power Subassemblies .....	2-6
Figure 2-4: ACLC Circuit Breaker Panel .....	2-7
Figure 2-5: DC Power Distribution Assembly .....	2-7
Figure 2-6: Meter Alarm Panel .....	2-9
Figure 2-7: Temperature Compensation Panel .....	2-10
Figure 2-8: Heat Exchanger Blower Assembly .....	2-13
Figure 3-1: Back and Front View of the CSU .....	3-5
Figure 3-2: 50 Pair Punch Block .....	3-6
Figure 3-3: CDMA LMF Folder Structure .....	3-15
Figure 3-4: BTS Folder Name Syntax Example .....	3-16
Figure 3-5: CAL File Name Syntax Example .....	3-16
Figure 3-6: CDF Name Syntax Example .....	3-16
Figure 3-7: Code Load File Name Syntax Example .....	3-18
Figure 3-8: DDS File Name Syntax Example .....	3-19
Figure 3-9: LMF Connection Detail .....	3-20
Figure 3-10: CDMA LMF Computer Common MMI Connections .....	3-27
Figure 3-11: BTS Ethernet LAN Interconnect Diagram .....	3-28
Figure 3-12: CSM MMI Terminal Connection .....	3-40
Figure 3-13: Cable Calibration Test Setup .....	3-50

---

## List of Figures – continued

Figure 3-14: TX Calibration Test Setup (CyberTest and HP 8935) . . . . .	3-51
Figure 3-15: TX Calibration Test Setup HP 8921A and Advantest . . . . .	3-52
Figure 3-16: Optimization/ATP Test Setup Calibration (CyberTest, HP 8935 and Advantest) . . . . .	3-53
Figure 3-17: Optimization/ATP Test Setup HP 8921A . . . . .	3-54
Figure 3-18: Calibrating Test Equipment Setup for TX Cable Calibration (Using Signal Generator and Spectrum Analyzer) . . . . .	3-60
Figure 3-19: Calibrating Test Equipment Setup for RX ATP Test (Using Signal Generator and Spectrum Analyzer) . . . . .	3-61
Figure 3-20: Battery Overtemperature Sensor . . . . .	3-90
Figure 3-21: Location of Connector J8 on the Meter Alarm Panel . . . . .	3-92
Figure 4-1: TX Mask Verification Spectrum Analyzer Display . . . . .	4-11
Figure 4-2: Code Domain Analyzer CD Power/Noise Floor Display Examples . . . . .	4-17
Figure 6-1: CSM Front Panel Indicators & Monitor Ports . . . . .	6-23
Figure 6-2: GLI2 Front Panel Operating Indicators . . . . .	6-26
Figure 6-3: MCC24 Front Panel LEDs and LED Indicators . . . . .	6-28
Figure 6-4: MGLI/GLI Board MMI Connection Detail . . . . .	6-30
Figure D-1: North America PCS Frequency Spectrum (CDMA Allocation) . . .	D-1
Figure D-2: North American Cellular Telephone System Frequency Spectrum (CDMA Allocation). . . . .	D-4
Figure F-1: HP8921A/600 Cables Connection for 10 MHz Signal and GPIB without Rubidium Reference . . . . .	F-2
Figure F-2: HP8921A Cables Connection for 10 MHz Signal and GPIB with Rubidium Reference . . . . .	F-4
Figure F-3: Cable Connections for Test Set without 10 MHz Rubidium Reference . . . . .	F-7
Figure F-4: Cable Connections for Test Set with 10 MHz Rubidium Reference . . . . .	F-8
Figure F-5: Cable Calibration Using HP8921 with PCS Interface . . . . .	F-13
Figure F-6: Cable Calibration using Advantest R3465 . . . . .	F-16
Figure F-7: Power Meter Detail . . . . .	F-17
Figure F-8: Gigatronics 8542C Power Meter Detail . . . . .	F-20



## List of Tables

### SC 4812ETL BTS Optimization/ATP

Release 2.15.x.x and CDMA LMF Build 2.15.x.x

Table 1-1: Non-Standard Terms and Abbreviations . . . . .	1-13
Table 1-2: SCCP Shelf/Cage Card/Module Device ID Numbers (Top Shelf) . . . . .	1-15
Table 1-3: SCCP Shelf/Cage Card/Module Device ID Numbers (Bottom Shelf) . . . . .	1-15
Table 1-4: BTS Sector Configuration . . . . .	1-22
Table 1-5: Sector Configurations . . . . .	1-23
Table 2-1: Initial Installation of Boards/Modules . . . . .	2-1
Table 2-2: Initial Inspection and Setup . . . . .	2-3
Table 2-3: AC Voltage Measurements . . . . .	2-4
Table 2-4: Pre-power DC Power Distribution System Test . . . . .	2-8
Table 2-5: Applying AC Power . . . . .	2-9
Table 2-6: Cabinet DC Power-Up Tests . . . . .	2-10
Table 2-7: Battery Charge Test (Connected Batteries) . . . . .	2-11
Table 2-8: Battery Discharge Test . . . . .	2-12
Table 3-1: Pin-Out for 50 Pin Punch Block . . . . .	3-7
Table 3-2: T1/E1 Span Isolation . . . . .	3-9
Table 3-3: CD ROM Installation . . . . .	3-10
Table 3-4: Copying CBSC CDF Files to the LMF Computer . . . . .	3-11
Table 3-5: Create HyperTerminal Connection . . . . .	3-13
Table 3-6: Connect the LMF to the BTS . . . . .	3-20
Table 3-7: BTS GUI Login Procedure . . . . .	3-22
Table 3-8: BTS CLI Login Procedure . . . . .	3-24
Table 3-9: BTS GUI Logout Procedure . . . . .	3-25
Table 3-10: BTS CLI Logout Procedure . . . . .	3-26
Table 3-11: Establishing MMI Communication . . . . .	3-26
Table 3-12: Pinging the Processors . . . . .	3-29
Table 3-13: Download and Enable MGLI and GLI Devices . . . . .	3-32
Table 3-14: Download RAM Code and Data to Non-GLI Devices . . . . .	3-33
Table 3-15: Select CSM Clock Source . . . . .	3-34



---

## List of Tables – continued

Table 3-16: Enable CSMs .....	3-35
Table 3-17: Enable MCCs .....	3-36
Table 3-18: Test Equipment Setup (GPS & LFR/HSO Verification) .....	3-39
Table 3-19: GPS Initialization/Verification .....	3-41
Table 3-20: LORAN–C Initialization/Verification .....	3-45
Table 3-21: Test Equipment Setup .....	3-48
Table 3-22: Selecting Test Equipment Manually in a Serial Connection Tab ..	3-56
Table 3-23: Selecting Test Equipment Using Auto-Detect .....	3-57
Table 3-24: Test Equipment Calibration .....	3-58
Table 3-25: Cable Calibration .....	3-59
Table 3-26: Calibrating TX Cables Using Signal Generator and Spectrum Analyzer .....	3-60
Table 3-27: Calibrating RX Cables Using a Signal Generator and Spectrum Analyzer .....	3-61
Table 3-28: Setting Cable Loss Values .....	3-62
Table 3-29: Setting TX Coupler Loss Values .....	3-63
Table 3-30: BLO BTS.cal file Array Branch Assignments .....	3-66
Table 3-31: BTS.cal File Array (Per Sector) .....	3-67
Table 3-32: Test Equipment Setup (RF Path Calibration) .....	3-68
Table 3-33: BTS TX Path Calibration .....	3-70
Table 3-34: Download BLO .....	3-71
Table 3-35: TX Path Audit .....	3-73
Table 3-36: All Cal/Audit Test .....	3-74
Table 3-37: Create CAL File .....	3-75
Table 3-38: RFDS Parameter Settings .....	3-77
Table 3-39: Definition of Parameters .....	3-78
Table 3-40: Valid NAM Field Ranges .....	3-79
Table 3-41: Set Antenna Map Data .....	3-80
Table 3-42: Set RFDS Configuration Data .....	3-81
Table 3-43: RFDS TSIC Calibration Channel Frequencies .....	3-82
Table 3-44: RFDS Calibration .....	3-83
Table 3-45: Program NAM Procedure .....	3-84
Table 3-46: Heat Exchanger Alarm .....	3-86
Table 3-47: Door Alarm .....	3-86
Table 3-48: AC Fail Alarm .....	3-86
Table 3-49: Minor Alarm .....	3-87
Table 3-50: Single Rectifier Fail or Minor Alarm .....	3-87

---

## List of Tables – continued

Table 3-51: Multiple Rectifier Failure or Major Alarm .....	3-88
Table 3-52: Single Rectifier Fail or Minor Alarm .....	3-88
Table 3-53: Multiple Rectifier Failure or Major Alarm .....	3-88
Table 3-54: Battery Over Temperature Alarm .....	3-89
Table 3-55: Rectifier Over Temperature Alarm .....	3-91
Table 3-56: Check Before Leaving the Site .....	3-92
Table 4-1: Set Up Test Equipment – TX Output Verify/Control Tests .....	4-3
Table 4-2: All TX/RX ATP Test Procedure .....	4-5
Table 4-3: All TX ATP Test Procedure .....	4-5
Table 4-4: All RX ATP Test Procedure .....	4-6
Table 4-5: Test Spectral Purity Transmit Mask .....	4-10
Table 4-6: Test Waveform Quality (Rho) .....	4-12
Table 4-7: Test Pilot Time Offset .....	4-13
Table 4-8: Test Code Domain Power/Noise Floor .....	4-16
Table 4-9: Test FER .....	4-19
Table 4-10: Generating an ATP Report .....	4-20
Table 5-1: Copying CAL Files to a Diskette .....	5-1
Table 5-2: Copying CAL Files from Diskette to the CBSC .....	5-1
Table 5-3: Remove External Test Equipment .....	5-3
Table 5-4: Reset BTS Devices and Remote Site Initialization .....	5-3
Table 5-5: Bring Modules into Service .....	5-4
Table 5-6: Remove LMF .....	5-4
Table 5-7: Connect T1 Span/Modem Cable .....	5-5
Table 6-1: Login Failure Troubleshooting Procedures .....	6-2
Table 6-2: Troubleshooting a Power Meter Communication Failure .....	6-2
Table 6-3: Troubleshooting a Communications Analyzer Communication Failure .....	6-3
Table 6-4: Troubleshooting Code Download Failure .....	6-4
Table 6-5: Troubleshooting Data Download Failure .....	6-4
Table 6-6: Troubleshooting Device Enable (INS) Failure .....	6-5
Table 6-7: LPA Errors .....	6-6
Table 6-8: Troubleshooting BLO Calibration Failure .....	6-7
Table 6-9: Troubleshooting Calibration Audit Failure .....	6-8
Table 6-10: Troubleshooting TX Mask Measurement Failure .....	6-9
Table 6-11: Troubleshooting Rho and Pilot Time Offset Measurement Failure .....	6-9
Table 6-12: Troubleshooting Code Domain Power and Noise Floor Measurement Failure .....	6-10

**List of Tables – continued**

Table 6-13: Troubleshooting Carrier Measurement Failure .....	6-10
Table 6-14: Troubleshooting Multi-FER Failure .....	6-11
Table 6-15: No GLI2 Control via LMF (all GLI2s) .....	6-16
Table 6-16: No GLI2 Control through Span Line Connection (Both GLI2s) ..	6-16
Table 6-17: MGLI2 Control Good – No Control over Co-located GLI2 .....	6-16
Table 6-18: MGLI2 Control Good – No Control over AMR .....	6-17
Table 6-19: MGLI2 Control Good – No Control over Co-located GLI2s .....	6-17
Table 6-20: BBX2 Control Good – No (or Missing) Span Line Traffic .....	6-17
Table 6-21: No MCC24 Channel Elements .....	6-17
Table 6-22: No DC Input Voltage to Power Supply Module .....	6-18
Table 6-23: No DC Input Voltage to any SCCP Shelf Module .....	6-19
Table 6-24: No DC Input Voltage to any SCCP Shelf Module .....	6-19
Table 6-25: RFDS Fault Isolation – All tests fail .....	6-20
Table 6-26: RFDS Fault Isolation – All RX and TX paths fail .....	6-20
Table 6-27: RFDS Fault Isolation – All tests fail on single antenna path .....	6-21
Table 6-28: Troubleshoot Control Link Failure .....	6-29
Table 6-29: Set BTS Span Parameter Configuration .....	6-31
Table A-1: Verification of Test Equipment Used .....	A-1
Table A-2: Site Checklist .....	A-2
Table A-3: Preliminary Operations .....	A-2
Table A-4: GPS Receiver Operation .....	A-5
Table A-5: LFR Receiver Operation .....	A-6
Table A-6: LPA IM Reduction .....	A-7
Table A-7: TX BLO Calibration (3-Sector: 1-Carrier, 2-Carrier and 4-Carrier Non-adjacent Channels) .....	A-8
Table A-8: TX Bay Level Offset Calibration (3-Sector: 2-Carrier Adjacent Channels) .....	A-9
Table A-9: TX Antenna VSWR .....	A-10
Table A-10: RX Antenna VSWR .....	A-11
Table A-11: CDI Alarm Input Verification .....	A-11
Table B-1: When RF Optimization Is required on the BTS .....	B-1
Table B-2: When to Optimize Inter-frame Cabling .....	B-2
Table B-3: SC 4812ET BTS Optimization and ATP Test Matrix .....	B-4
Table C-1: BBX2 Gain Set Point vs. Actual BTS Output (in dBm) .....	C-1
Table D-1: 1900 MHz TX and RX Frequency vs. Channel .....	D-2
Table D-2: 800 MHz TX and RX Frequency vs. Channel .....	D-4
Table E-1: PnMaskI and PnMaskQ Values for PilotPn .....	E-3

---

## List of Tables – continued

Table F-1: HP8921A/600 Communications Test Set Rear Panel Connections Without Rubidium Reference .....	F-1
Table F-2: HP8921A/600 Communications Test Set Rear Panel Connections With Rubidium Reference .....	F-3
Table F-3: System Connectivity .....	F-5
Table F-4: Setting HP8921A GPIB Address .....	F-6
Table F-5: Pretest Setup for HP8921A .....	F-6
Table F-6: Pretest Setup for HP8935 .....	F-6
Table F-7: Advantest R3465 GPIB Address and Clock Setup .....	F-9
Table F-8: Pretest Setup for Advantest R346 .....	F-9
Table F-9: Calibrating Test Cable Setup (using the HP PCS Interface) .....	F-10
Table F-10: Procedure for Calibrating Test Cable Setup Using Advantest R3465 .....	F-14
Table F-11: Power Meter Calibration Procedure .....	F-17
Table F-12: Calibrate Gigatronix 8542 Power Meter .....	F-19
Table G-1: Download ROM and RAM Code to Devices .....	G-2

---

## Product Information

### Model & Options Charts

Refer to the *SC 4812ET Lite Field Replaceable Units* manual (68P TBS) for detailed model structure and option information

This document covers only the steps required to verify the functionality of the Base Transceiver Subsystem (BTS) equipment prior to system level testing, and is intended to supplement site specific application instructions. It also should be used in conjunction with existing product manuals. Additional steps may be required.

---

## Foreword

### Scope of manual

This manual is intended for use by cellular telephone system craftspersons in the day-to-day operation of Motorola cellular system equipment and ancillary devices. It is assumed that the user of this information has a general understanding of telephony, as used in the operation of the Public Switched Telephone Network (PSTN), and is familiar with these concepts as they are applied in the cellular mobile/portable radiotelephone environment. The user, however, is not expected to have any detailed technical knowledge of the internal operation of the equipment.

This manual is not intended to replace the system and equipment training offered by Motorola, although it can be used to supplement or enhance the knowledge gained through such training.

### Text conventions

The following special paragraphs are used in this manual to point out information that must be read. This information may be set-off from the surrounding text, but is always preceded by a bold title in capital letters. The four categories of these special paragraphs are:

#### **NOTE**

Presents additional, helpful, non-critical information that you can use.



#### **IMPORTANT**

Presents information to help you avoid an undesirable situation or provides additional information to help you understand a topic or concept.



#### **CAUTION**

Presents information to identify a situation in which equipment damage could occur, thus avoiding damage to equipment.



#### **WARNING**

Presents information to warn you of a potentially hazardous situation in which there is a possibility of personal injury.

The following special paragraphs are used in tables in the manual to point out information that must be read.

<b>NOTE</b> Presents additional, helpful non-critical information that you can use.
<b>* IMPORTANT</b> Presents information to help you avoid an undesirable situation or provide additional information to help you understand a topic or concept.
<b>! CAUTION</b> Presents information to identify a situation where equipment damage could occur and help you avoid damaging your equipment.
<b>Δ WARNING</b> Presents information to warn you of a potentially hazardous situation where there is a possibility of personal injury (serious or otherwise).

### Changes to manual

Changes that occur after the printing date are incorporated into your manual by Cellular Manual Revisions (CMRs). The information in this manual is updated, as required, by a CMR when new options and procedures become available for general use or when engineering changes occur. The cover sheet(s) that accompany each CMR should be retained for future reference. Refer to the Revision History page for a list of all applicable CMRs contained in this manual.

### Receiving updates

Technical Education & Documentation (TED) maintains a customer database that reflects the type and number of manuals ordered or shipped since the original delivery of your *Motorola* equipment. Also identified in this database is a “key” individual (such as Documentation Coordinator or Facility Librarian) designated to receive manual updates from TED as they are released.

To ensure that your facility receives updates to your manuals, it is important that the information in our database is correct and up-to-date. Therefore, if you have corrections or wish to make changes to the information in our database (i.e., to assign a new “key” individual), please contact Technical Education & Documentation at:

MOTOROLA, INC.  
Technical Education & Documentation  
1 Nelson C. White Parkway  
Mundelein, Illinois 60060  
U.S.A.

Phone:  
Within U.S.A. and Canada . . . . . 800-872-8225  
Outside of U.S.A. and Canada . . . +1-847-435-5700  
FAX: . . . . . +1-847-435-5541

**Reporting manual errors**

In the event that you locate an error or identify a deficiency in your manual, please take time to write to us at the address above. Be sure to include your name and address, the complete manual title and part number (located on the manual spine, cover, or title page), the page number (found at the bottom of each page) where the error is located, and any comments you may have regarding what you have found. We appreciate any comments from the users of our manuals.



---

## General Safety

### Remember! . . . Safety depends on you!!

The following general safety precautions must be observed during all phases of operation, service, and repair of the equipment described in this manual. Failure to comply with these precautions or with specific warnings elsewhere in this manual violates safety standards of design, manufacture, and intended use of the equipment. Motorola, Inc. assumes no liability for the customer's failure to comply with these requirements. The safety precautions listed below represent warnings of certain dangers of which we are aware. You, as the user of this product, should follow these warnings and all other safety precautions necessary for the safe operation of the equipment in your operating environment.

### Ground the instrument

To minimize shock hazard, the equipment chassis and enclosure must be connected to an electrical ground. If the equipment is supplied with a three-conductor ac power cable, the power cable must be either plugged into an approved three-contact electrical outlet or used with a three-contact to two-contact adapter. The three-contact to two-contact adapter must have the grounding wire (green) firmly connected to an electrical ground (safety ground) at the power outlet. The power jack and mating plug of the power cable must meet International Electrotechnical Commission (IEC) safety standards.

### Do not operate in an explosive atmosphere

Do not operate the equipment in the presence of flammable gases or fumes. Operation of any electrical equipment in such an environment constitutes a definite safety hazard.

### Keep away from live circuits

Operating personnel must:

- not remove equipment covers. Only Factory Authorized Service Personnel or other qualified maintenance personnel may remove equipment covers for internal subassembly, or component replacement, or any internal adjustment.
- not replace components with power cable connected. Under certain conditions, dangerous voltages may exist even with the power cable removed.
- always disconnect power and discharge circuits before touching them.

### Do not service or adjust alone

Do not attempt internal service or adjustment, unless another person, capable of rendering first aid and resuscitation, is present.

---

## General Safety – continued

### Use caution when exposing or handling the CRT

Breakage of the Cathode-Ray Tube (CRT) causes a high-velocity scattering of glass fragments (implosion). To prevent CRT implosion, avoid rough handling or jarring of the equipment. The CRT should be handled only by qualified maintenance personnel, using approved safety mask and gloves.

### Do not substitute parts or modify equipment

Because of the danger of introducing additional hazards, do not install substitute parts or perform any unauthorized modification of equipment. Contact Motorola Warranty and Repair for service and repair to ensure that safety features are maintained.

### Dangerous procedure warnings

Warnings, such as the example below, precede potentially dangerous procedures throughout this manual. Instructions contained in the warnings must be followed. You should also employ all other safety precautions that you deem necessary for the operation of the equipment in your operating environment.



#### **WARNING**

Dangerous voltages, capable of causing death, are present in this equipment. Use extreme caution when handling, testing, and adjusting.

---

## Revision History

### Manual Number

68P09250A99-1

### Manual Title

SC 4812ETL BTS Optimization/ATP  
Release 2.15.x.x and CDMA LMF Build 2.15.x.x

### Version Information

The following table lists the manual version , date of version, and remarks on the version.

<b>Version Level</b>	<b>Date of Issue</b>	<b>Remarks</b>
-1	08/15/2000	Initial draft

---

## Patent Notification

### Patent numbers

This product is manufactured and/or operated under one or more of the following patents and other patents pending:

4128740	4661790	4860281	5036515	5119508	5204876	5247544	5301353
4193036	4667172	4866710	5036531	5121414	5204977	5251233	5301365
4237534	4672657	4870686	5038399	5123014	5207491	5255292	5303240
4268722	4694484	4872204	5040127	5127040	5210771	5257398	5303289
4282493	4696027	4873683	5041699	5127100	5212815	5259021	5303407
4301531	4704734	4876740	5047762	5128959	5212826	5261119	5305468
4302845	4709344	4881082	5048116	5130663	5214675	5263047	5307022
4312074	4710724	4885553	5055800	5133010	5214774	5263052	5307512
4350958	4726050	4887050	5055802	5140286	5216692	5263055	5309443
4354248	4729531	4887265	5058136	5142551	5218630	5265122	5309503
4367443	4737978	4893327	5060227	5142696	5220936	5268933	5311143
4369516	4742514	4896361	5060265	5144644	5222078	5271042	5311176
4369520	4751725	4910470	5065408	5146609	5222123	5274844	5311571
4369522	4754450	4914696	5067139	5146610	5222141	5274845	5313489
4375622	4764737	4918732	5068625	5152007	5222251	5276685	5319712
4485486	4764849	4941203	5070310	5155448	5224121	5276707	5321705
4491972	4775998	4945570	5073909	5157693	5224122	5276906	5321737
4517561	4775999	4956854	5073971	5159283	5226058	5276907	5323391
4519096	4797947	4970475	5075651	5159593	5228029	5276911	5325394
4549311	4799253	4972355	5077532	5159608	5230007	5276913	5327575
4550426	4802236	4972432	5077741	5170392	5233633	5276915	5329547
4564821	4803726	4979207	5077757	5170485	5235612	5278871	5329635
4573017	4811377	4984219	5081641	5170492	5235614	5280630	5339337
4581602	4811380	4984290	5083304	5182749	5239294	5285447	D337328
4590473	4811404	4992753	5090051	5184349	5239675	5287544	D342249
4591851	4817157	4998289	5093632	5185739	5241545	5287556	D342250
4616314	4827507	5020076	5095500	5187809	5241548	5289505	D347004
4636791	4829543	5021801	5105435	5187811	5241650	5291475	D349689
4644351	4833701	5022054	5111454	5193102	5241688	5295136	RE31814
4646038	4837800	5023900	5111478	5195108	5243653	5297161	
4649543	4843633	5028885	5113400	5200655	5245611	5299228	
4654655	4847869	5030793	5117441	5203010	5245629	5301056	
4654867	4852090	5031193	5119040	5204874	5245634	5301188	

## Chapter 1: Introduction

### Table of Contents

---

Optimization Manual Scope and Layout .....	1-1
Manual Scope and Layout .....	1-1
Assumptions and Prerequisites .....	1-1
Document Composition .....	1-2
Purpose of the Optimization .....	1-3
Why Optimize? .....	1-3
What Is Optimization? .....	1-3
What Happens During Optimization .....	1-3
When to Optimize .....	1-4
New Installations .....	1-4
Site Expansion .....	1-4
Periodic Optimization .....	1-4
Repaired Sites .....	1-4
Required Test Equipment and Software .....	1-5
Policy .....	1-5
Test Equipment Calibration .....	1-5
Test Cable Calibration .....	1-5
Equipment Warm-up .....	1-5
Required Test Equipment and Software .....	1-6
Optional Equipment .....	1-10
Required Documents and Related Publications .....	1-12
Required Documents .....	1-12
Related Publications .....	1-12
Terms and Abbreviations .....	1-13
Overview .....	1-13
BTS Equipment Identification .....	1-14
Equipment Overview .....	1-14
Logical BTS .....	1-14
Major Components .....	1-16
Internal Assemblies and FRUs .....	1-17
Sector Configuration .....	1-22



## Manual Scope and Layout

This document provides information pertaining to the optimization and audit tests of the Motorola SC4812ET Lite RF Base Transceiver Station (BTS) equipment frame and its associated internal and external interfaces. The following subjects are addressed: preliminary background information; optimization, and alarm/redundancy tests; Acceptance Test Procedures (ATP) to verify site operation and regulation compliance; site turnover; troubleshooting.

Most applications use the same test procedure for all equipment variations. However, decision break points are provided throughout the procedure when equipment-specific tests are required. For example, when tests using external test equipment are performed instead of those using the RFDS, additional test procedures and illustrations are provided to cover both applications.

This optimization procedure consists of a group of task-oriented tests. Each major test category (Audit, Initial power-up, Calibration tests, etc.) is described in chapters which are broken down into multi-page “maps.”

Each “map” typically consists of pages containing all the information necessary to perform the test (including all required input levels, output levels, CDMA Local Maintenance Facility (CDMA LMF) commands, and test points required). Also described are some of the main concepts you must understand in the test process. Whenever possible, graphics, flowcharts, or other examples complement the information/steps.

## Assumptions and Prerequisites

This document assumes that the BTS frames and cabling have been installed per the *BTS Frame Installation Manual – 68P09226A18*, which covers the physical “bolt down” of all SC series equipment frames, and the *BTS Hardware Installation Manual – 68P09252A36*, which covers BTS-specific cabling configurations.

**Document Composition**

This document covers the following major areas:

- Introduction, consisting of preliminary background information (such as component and subassembly locations and frame layouts) to be considered by the Cellular Field Engineer CFE before performing optimization or tests.
- Preliminary Operations, consisting of jumper configuration of BTS sub-assemblies, pre-power-up tests, initial application of power to the BTS equipment frames, and initial power-up tests.
- Optimization/Calibration, consisting of procedures for downloading all BTS processor boards, test equipment setup, RF path verification, BLO calibration and calibration audit, and Radio Frequency Diagnostic System (RFDS) calibration.
- Acceptance Test Procedures (ATP), consisting of automated ATP tests, executed by the CDMA LMF, and used to verify all major TX and RX performance characteristics on all BTS equipment. This chapter also covers generating an ATP report.
- Prepare to Leave the Site, discussing site turnover after ATP is completed.
- Basic Troubleshooting, consisting of procedures to perform when an ATP fails, as well as when incorrect results are obtained during logon, test equipment operation, calibration, and GPS operation.
- Appendices that contain pertinent PN offset, frequency programming, and output power data tables, along with additional data sheets that are filled out manually by the CFE at the site.



## Why Optimize?

Proper optimization and calibration ensures that:

- Accurate downlink RF power levels are transmitted from the site.
- Accurate uplink signal strength determinations are made by the site.

## What Is Optimization?

Optimization compensates for the site-specific cabling and normal equipment variations. Site optimization guarantees that the combined losses of the new cables and the gain/loss characteristics and built-in tolerances of each BTS frame do not accumulate and cause improper site operation.

## What Happens During Optimization

Optimization identifies the accumulated loss (or gain) for each receive and transmit path at the BTS site, and stores these values in a database.

- A receive path (RX) starts at the ancillary equipment frame RFDS RX directional coupler antenna feedline port and travels through the RX input port on the top of the frame, through the bandpass filter, MPC and additional splitter circuitry, ending at a Broad Band Transceiver (BBX) backplane slot in the CDMA Channel Processor (CCP) shelf.
- A transmit path (TX) starts at the BBX backplane slot, is routed through the BBX I/O to the TX Combiner, travels through the ELPA, and ends either at an antenna port on top of the frame or RFDS TX directional coupler antenna feedline port.

Six of the seven BBX2 boards in each S-CCP shelf are optimized to specific RX and TX antenna ports. The seventh BBX2 board acts in a redundant capacity for BBX2 boards 1 through 6, and is optimized to all antenna ports. A single value is generated for each complete path, thereby eliminating the accumulation of error that would occur from individually measuring and summing the gain and loss of each element in the path.

BTS equipment factors in these values internally, leaving only site-specific antenna feed line loss and antenna gain characteristics to be factored in by the CFE when determining site ERP output power requirements.

---

## When to Optimize

### New Installations

After the initial site installation, the BTS must be prepared for operation. This preparation includes verifying hardware installation, initial power-up, downloading of operating code, verifying GPS operation and verifying transmit and receive paths.

Next, the optimization is performed. Optimization includes performance verification and calibration of all transmit and receive RF paths, and download of accumulated calibration data.

A calibration audit of all RF transmit paths may be performed any time after optimization to verify BTS calibration.

After optimization, a series of manual pre-Acceptance Test Procedure (ATP) verification tests are performed to verify alarm/redundancy performance.

After manual pre-ATP verification tests, a series of ATPs are performed to verify BTS performance. An ATP is also required before the site can be placed in service.

### Site Expansion

Optimization is also required after expansion of a site.

### Periodic Optimization

Periodic optimization of a site may also be required, depending on the requirements of the overall system.

### Repaired Sites



#### IMPORTANT

Refer to Appendix B for a detailed FRU Optimization/ATP Test Matrix outlining the minimum tests that must be performed *any time* a BTS subassembly or RF cable associated with it is replaced.

## Policy

To ensure consistent, reliable, and repeatable optimization test results, test equipment and software meeting the following technical criteria should be used to optimize the BTS equipment. Test equipment can, of course, be substituted with other test equipment models *if the equipment meets the same technical specifications*.

*It is the responsibility of the customer to account for any measurement variances and/or additional losses/inaccuracies that can be introduced as a result of these substitutions.* Before beginning optimization or troubleshooting, make sure that the test equipment needed is on hand and operating properly.

## Test Equipment Calibration

Optimum system performance and capacity depend on regular equipment service, calibration, and characterization prior to BTS optimization. Follow the original equipment manufacture (OEM) recommended maintenance and calibration schedules closely.

## Test Cable Calibration

Equipment test cables are very important in optimization. It is recommended that the cable calibration be run at every BTS with the test cables attached. This method compensates for test cable insertion loss within the test equipment itself. No other allowance for test cable insertion loss needs to be made during the performance of tests.

Another method is to account for the loss by entering it into the CDMA LMF during the optimization procedure. This method requires accurate test cable characterization in a shop. The cable should be tagged with the characterization information prior to field optimization.

## Equipment Warm-up

After arriving at the a site, the test equipment should be plugged in and turned on to allow warm up and stabilization to occur for as long as possible. The following pieces of test equipment must be warmed up for *a minimum of 60 minutes* prior to using for BTS optimization or RFDS calibration procedures:

- Communications test set.
- Rubidium time base.
- Power meter.

## Required Test Equipment and Software – continued

### Required Test Equipment and Software

The following test equipment and software is required for the optimization procedure. You will also need common assorted tools such as screwdrivers and frame keys. Read the owner's manual for all of the test equipment to understand its individual operation before using the tool in the optimization.

#### NOTE

Always refer to specific OEM test equipment documentation for detailed operating instructions.

### CDMA LMF Hardware Requirements

A CDMA LMF computer platform that meets the following requirements (or better) is recommended:

- Notebook computer
- 266 MHz (32 bit CPU) Pentium processor
- 4 Gbyte internal hard disk drive
- SVGA 12.1–inch active matrix color display with 1024 x 768 (recommended) or 800 x 600 pixel resolution
- 64 MB RAM minimum (128 MB recommended)
- 20X CD–ROM drive
- 3 1/2 inch floppy drive
- 56kbps V.90 modem
- Serial port (COM 1)
- Parallel port (LPT 1)
- PCMCIA Ethernet interface card (for example, 3COM Etherlink III) with a 10BaseT–to–coax adapter
- Windows 98 Second Edition (SE) operating system

#### NOTE

If 800 x 600 pixel resolution is used, the CDMA LMF window must be maximized after it is displayed.

### CDMA LMF Software

The CDMA LMF is a graphical user interface (GUI) based Local Maintenance Facility (LMF). This software product is specifically designed to provide cellular communications field personnel the vehicle to support the following CDMA Base Transceiver Stations (BTS) operations:

- Installation

- Maintenance
- Calibration
- Optimization

**Ethernet LAN Transceiver** (*part of CGDSL MFCOMPAQNOV96*)

- PCMCIA Ethernet Adapter + Ethernet UTP Adapter  
3COM Model – Etherlink III 3C589B

*used with*

- Transition Engineering Model E-CX-TBT-03 10BaseT/10Base2 Converter (or equivalent)

**NOTE**

Xircom Model PE3-10B2 or its equivalent can also be used to interface the CDMA LMF Ethernet connection to the RFM frame.

**RS-232 to GPIB interface**

- National Instruments GPIB-232-CT with Motorola CGDSEDN04X RS232 serial cable or equivalent; used to interface the CDMA LMF to the test equipment.
- *A standard RS-232 cable can be used with the following modifications:*
  - Pin 8 (CTS) does not have to be jumpered/shorted to the others as it is a driver output. The DTR is already a driver output signal. The other pins are to receivers. Short pins 7, 1, 4, 6 on each cable end:

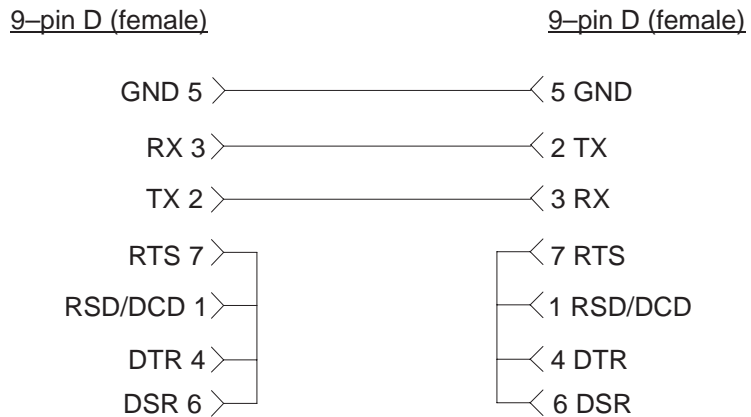

**Model SLN2006A MMI interface kit**

- Motorola Model TRN9666A null modem board. Connectors on opposite sides of the board must be used as this performs a null modem transformation between cables. This board can be used for 10-pin to 8-pin, 25-pin to 25-pin, and 10-pin to 10-pin conversions.
- Motorola 30-09786R01 MMI cable or equivalent ; used to interface the CDMA LMF serial port connection to the GLI, CSM, ETIB board, and module debug serial ports.

**Communications system analyzer CDMA/analog**

The following communications system analyzers are supported by the LMF:

- Motorola CyberTest
- Advantest R3465 Analyzer with R3561L Signal Generator
- Hewlett Packard Model HP 8921A/600 Analyzer including 83203B CDMA Interface, manual control system card, and 83236A/B PCS Interface for 1900 MHz BTSs.
- Hewlett Packard Model HP 8935 Analyzer

*or a combination of test equipment supported by the CDMA LMF and used during optimization and testing of the RF communications portion of BTS equipment.*

The analyzer provides the following functions:

- Frequency counter.
- Deviation meter.
- RF power meter (average and code domain).
- RF signal generator (capable of DSAT/CDMA modulation).
- Audio signal generator.
- AC voltmeter (with 600-ohm balanced audio input and high impedance input mode).
- Noise measurement meter.
- C-Message filter.
- Spectrum analyzer.
- CDMA code domain analyzer.

 **GPIB cables**

Hewlett Packard 10833A or equivalent; one or two meters long, used to interconnect test equipment and CDMA LMF terminal.

**Power meter**

- Hewlett Packard Model HP437B with HP8481A power sensor capable of measuring from -30 dBm to 20 dBm,

or

- Gigatronics 8542B power meter.

**Timing reference cables**

- *Two* Huber & Suhner 16MCX/11BNC/K02252D or equivalent; right angle MCX–male to standard BNC–male RG316 cables; 10 ft. long are required to interconnect the HP8921A/600 Communications Analyzer to SGLN4132A and SGLN1145A CSM board timing references,

or

- *Two* BNC–male to BNC–male RG316 cables; 3 meters (10 feet) long, used to interconnect the HP8921A/600 Communications Analyzer to SGLN4132B and SGLN1145B (and later) CSM front panel timing references in the RF Modem Frame.

**Digital multimeter**

Fluke Model 8062A with Y8134 test lead kit or equivalent; used for precision DC and AC measurements to four decimal places.

**Directional coupler**

Narda Model 3020A 20 dB coupler terminated with two Narda Model 375BN–M loads, or equivalent.

**RF attenuators**

- 20 dB Fixed attenuator, 20 Watt (Narda 768–20), used in conjunction with calibration of test cables or during general troubleshooting procedures.
- 10 dB Fixed attenuator, 20 Watt (Narda 768–10), for cable calibration with a Cybertest CDMA analyzer.

**Miscellaneous RF adapters, loads, etc.**

As required to interface test cables and BTS equipment and for various test setups. Should include at least (2) 50 Ohm loads (type N) for calibration and (1) RF short.

**RF load**

100W non–radiating RF load used (as required) to provide dummy RF loading during BTS transmit tests.

**High–impedance conductive wrist strap**

Motorola Model 42–80385A59; used to prevent damage from ESD when handling or working with modules.

---

## Required Test Equipment and Software – continued

### Optional Equipment

This section provides a list of additional equipment that might be required during maintenance and troubleshooting operations.

#### NOTE

Not all optional equipment specified in this section will be supported by the CDMA LMF in automated tests.

#### Duplexer

Filtronics Low IM Duplexer (Cm035-f2) or equivalent; used during Spectral Purity Receive band noise tests.

#### Frequency counter

Stanford Research Systems SR620 or equivalent; used if direct measurement of the 3 MHz or 19.6608 MHz references is required.

#### Spectrum analyzer

Spectrum Analyzer (HP8594E with CDMA personality card) or equivalent; required for *manual* tests other than standard Receive band spectral purity and TX LPA IM reduction verification tests performed by the CDMA LMF.

#### LAN tester

Model NETcat 800 LAN troubleshooter (or equivalent); used to supplement LAN tests using the ohm meter.

#### Span line (T1/E1) verification equipment

As required for the local application.

#### RF test cable (if not provided with test equipment)

Motorola Model TKN8231A; used to connect test equipment to the BTS transmitter output during optimization or during general troubleshooting procedures.

#### Oscilloscope

Tektronics Model 2445 or equivalent; used for waveform viewing, timing, and measurements, or during general troubleshooting procedures.

#### 2-way splitter

Mini-Circuits Model ZFSC-2-2500 or equivalent; used to provide the diversity receive input to the BTS.

#### CDMA subscriber mobile or portable radiotelephone

Safco Model 2136-150 with power supply and antenna; used to provide test transmission and reception during BTS maintenance and



troubleshooting. *Do not substitute other models that do not feature special test modes.* Two radios will be required for system and drive-around testing *after* optimization and BTS ATP are completed.

**RF circulator**

Circulator (FERROCOM 5809866C01) or equivalent; can substitute for a duplexer during Receive sensitivity FER testing in conjunction with Safco CDMA mobile.

**High stability 10 MHz rubidium standard**

Stanford Research Systems SR625 or equivalent. Required for CSM and LFR/HSO frequency verification.

---

## Required Documents and Related Publications

### Required Documents

The following documents are required to perform optimization of the cell site equipment:

- Site Document (generated by Motorola Systems Engineering), which includes:
  - General site information
  - Floor plan
  - RF power levels
  - Frequency plan (includes Site PN and operating frequencies)
  - Channel allocation (paging, traffic, etc.)
  - Board placement
  - Site wiring list
  - *Site-specific CDF file*
- Demarcation Document (Scope of Work Agreement)
- Equipment manuals for non-Motorola test equipment
- CDMA LMF Operator's Guide (Motorola part number 68P64114A21)

### Related Publications

Additional, detailed information about the installation, operation, and maintenance of the SC4812ET Lite BTS is included in the following publications:

## Overview

Standard terms and abbreviations used in this manual are defined in *Cellular Glossary of Terms and Acronyms – 68P09213A95*. Any non-standard terms or abbreviations included in this manual are listed in Table 1-1.

<b>Term or Abbreviation</b>	<b>Definition</b>

# BTS Equipment Identification

## Equipment Overview

The SC4812ETL BTS consists of a single, outdoor, weatherized cabinet containing RF and power components. The BTS is functionally similar to the two-cabinet SC4812ET, but provides more flexibility in site selection because of its smaller footprint and lighter weight. The BTS is powered by 220 Vac, rectified internally to +27 Vdc, and can support two carriers in a 3-sector configuration. An SC4812ETL starter frame with the maximum of one SC4812ETL expansion frame can support 4 carriers in a 3-sector configuration. Six-sector operation is not supported with any SC4812ETL configuration.

The BTS cabinet houses the fan modules, RF compartment heat exchanger, Simplified CDMA Channel Processor shelf (S-CCP), RF Linear Power Amplifier (LPA) modules, LPA trunking modules, bandpass filters, 2:1 combiners, and Duplexer/Receive Filter/Directional Couplers (DRDC). Power components include a +27 Vdc Power Distribution Assembly (PDA), backup batteries, battery heaters, rectifiers, an AC Load Center (ACLC), and one duplex GFCI 115 Vac utility outlet.

## Logical BTS

A logical BTS can consist of up to two SC4812ETL frames. When the LMF is connected to frame 1 of a logical BTS, access is available to all devices in all of the frames that make up the logical BTS. A logical BTS CDF file that includes equipment information for all of the logical BTS frames and their devices is required. A CBSC file that includes channel data for all of the logical BTS frames is also required.

The first frame of a logical BTS has a **-1** suffix (e.g., **BTS-812-1**) and the second frame of the logical BTS is numbered with the suffix, **-101** (e.g. **BTS-812-101**). When the CDMA LMF is logged into a BTS, a **FRAME** tab is displayed for each frame. If there is only one frame for the BTS, there will only be one tab (e.g., **FRAME-282-1** for **BTS-282**). If a logical BTS has more than one frame, there will be a separate **FRAME** tab for each frame (e.g. **FRAME-438-1**, and **FRAME-438-101** for **BTS-438** that has both frames). If an RFDS is included in the CDF file, an **RFDS** tab (e.g., **RFDS-438-1**) will be displayed.

Actions (e.g., ATP tests) can be initiated for selected devices in one or more frames of a logical BTS. Refer to the Select devices help screen for information on how to select devices.

### SCCP Shelf Card/Module Device ID Numbers

All cards/modules/boards in the frames at a single site, assigned to a single BTS number, are also identified with unique Device ID numbers dependent upon the Frame ID number in which they are located. Refer to Table 1-2, Table 1-3, and Figure 1-4 for specific SCCP Shelf Device ID numbers.

**Table 1-2: SCCP Shelf/Cage Card/Module Device ID Numbers (Top Shelf)**

Frame #	Card/Module ID Number (Left to Right)										
	Power (PS-1)	Power (PS-2)	AMR -1	GLI2 -1	MCC2		BBX2			BBX2 -R	MPC/EMPC -1
1	-	-	1	1	1	2	1	2	3	R1	-
101	-	-	101	101	101	102	101	102	103	R101	-

**Table 1-3: SCCP Shelf/Cage Card/Module Device ID Numbers (Bottom Shelf)**

Frame #	Card/Module ID Number (Left to Right)														
	HSO/LFR	CSM -1	CSM -2	CCD A	CCD B		AMR -2	GLI2-2	MCC2			BBX2			SW
1	-	1	2	-	-	-	2	2	3	4	4	5	6	-	-
101	-	101	102	-	-	-	102	102	107	108	107	108	109	-	-

Figure 1-1: Typical Logical BTS Configurations

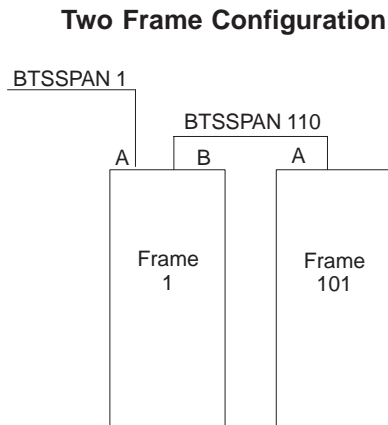

# Cabinet Identification

## Major Components

Figure 1-2 illustrates the features of the BTS Cabinet, the single major component of the Motorola SC4812ETL.

Figure 1-2: SC4812ETL Cabinet

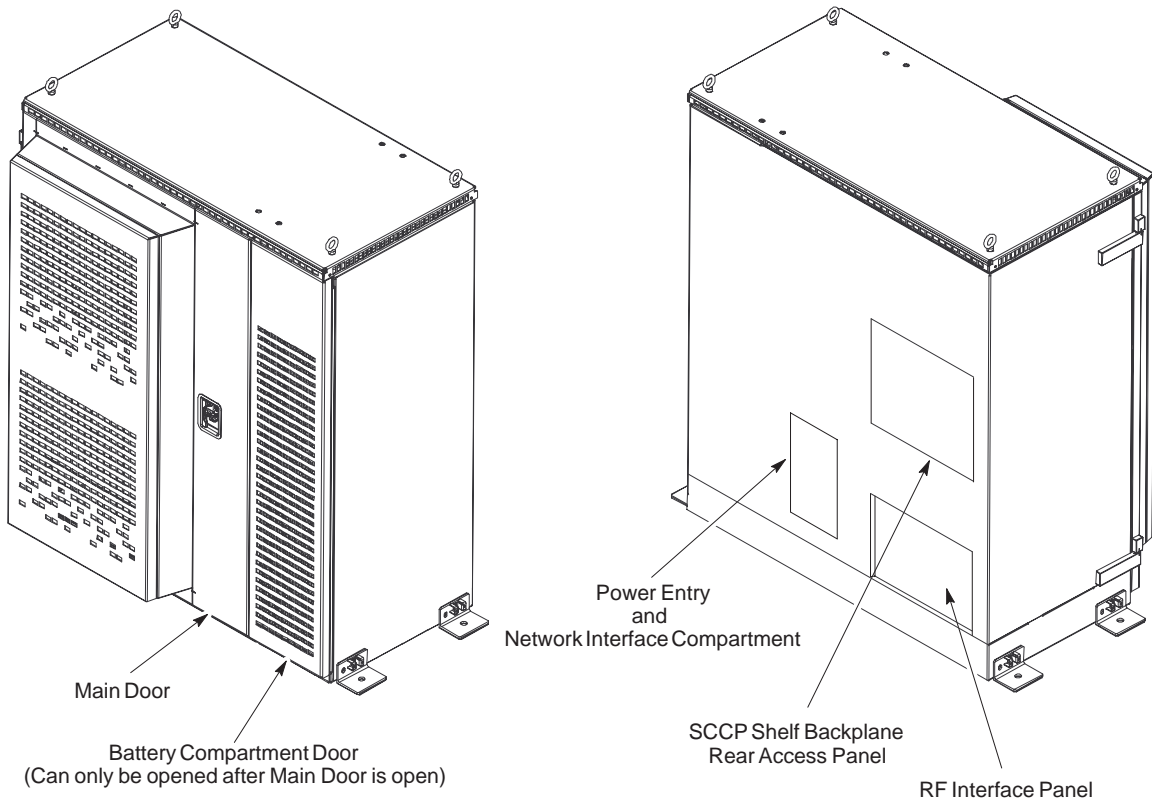

SC4812ETL0001-1

# Internal Assembly Location and Identification

## Internal Assemblies and FRUs

Figure 1-3 shows the location of the internal assemblies and Field Replaceable Units (FRU). A brief description of each item is found in the following paragraphs.

**Figure 1-3:** Internal Assemblies and FRUs  
(Cabinet doors not shown for clarity)

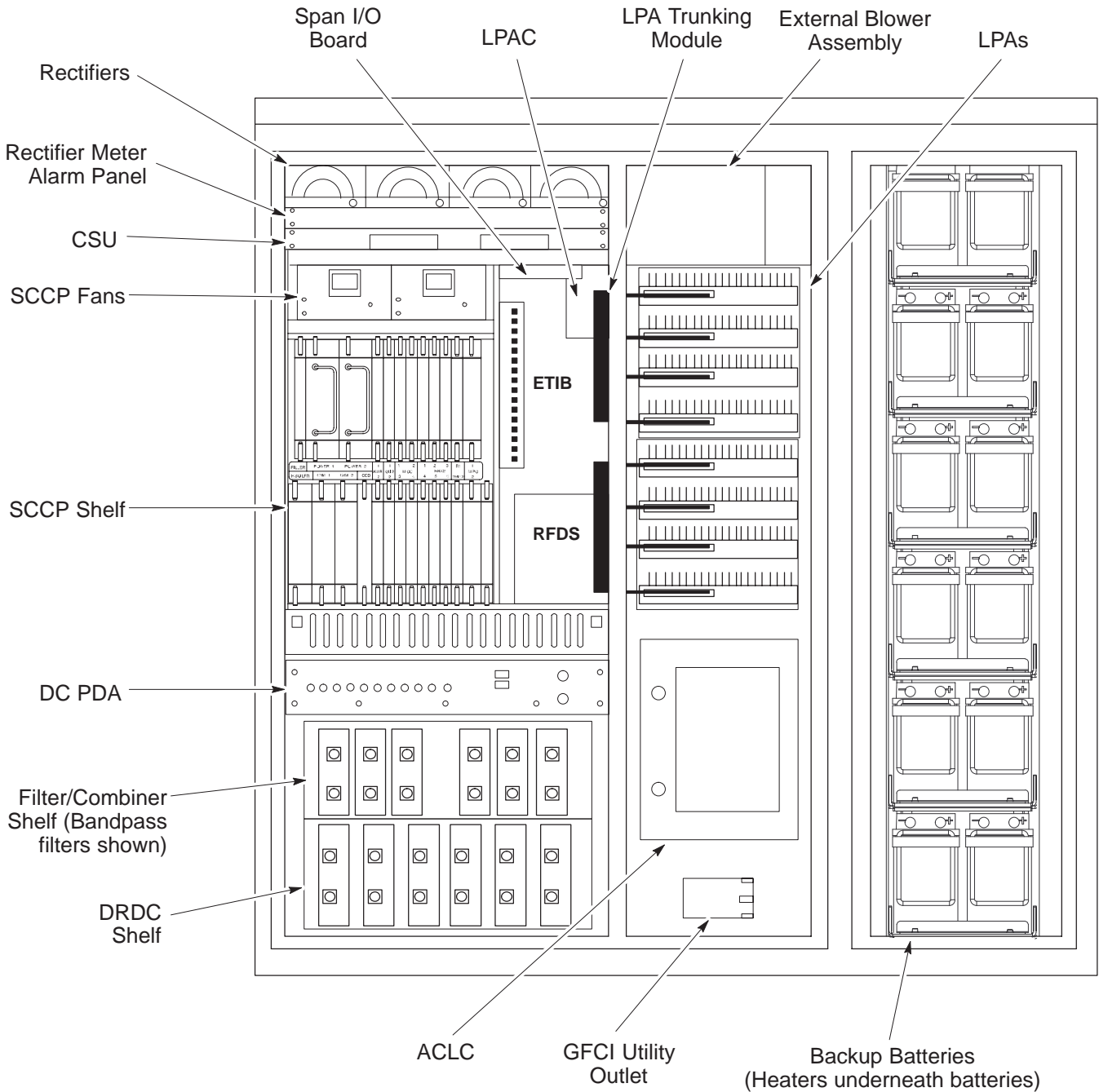

SC4812ETL0002-1

**Duplexer/Directional Coupler (DRDC)**

The DRDC combines, in a single module, the functions of antenna duplexing, receive band pass filtering, and surge protection (see Figure 1-6).

**Filter/Combiner Shelf (Bandpass Filters or 2:1 Combiners)**

The Filter/Combiner Shelf holds the transmit band pass filters or 2:1 combiners, depending on system configuration.

**Simplified CDMA Channel Processor (SCCP) Shelf**

The SCCP shelf contains the following (see Figure 1-4):

- High Stability Oscillator (HSO)/LFR (Optional) card
- Clock Synchronization Manager (CSM) on 2 cards (one with GPS receiver, if ordered).
- CDMA Clock Distribution (CCD) cards (2)
- Power Supply cards (2)
- Multicoupler Preselector Cards (MPC) (2)
- Alarm Monitoring and Reporting (AMR) cards (2)
- Multi-Channel CDMA (MCC24) cards (up to 4)
- Broadband Transceiver (BBX2) cards (up to 6 with one redundant)
- Combined Input/Output (CIO) (1)
- Group Line Interface (GLI2) cards (2)
- BBX2 Switch card (1)
- Filler Panel
- Fan Module (2)



Figure 1-4: SCCP Shelf

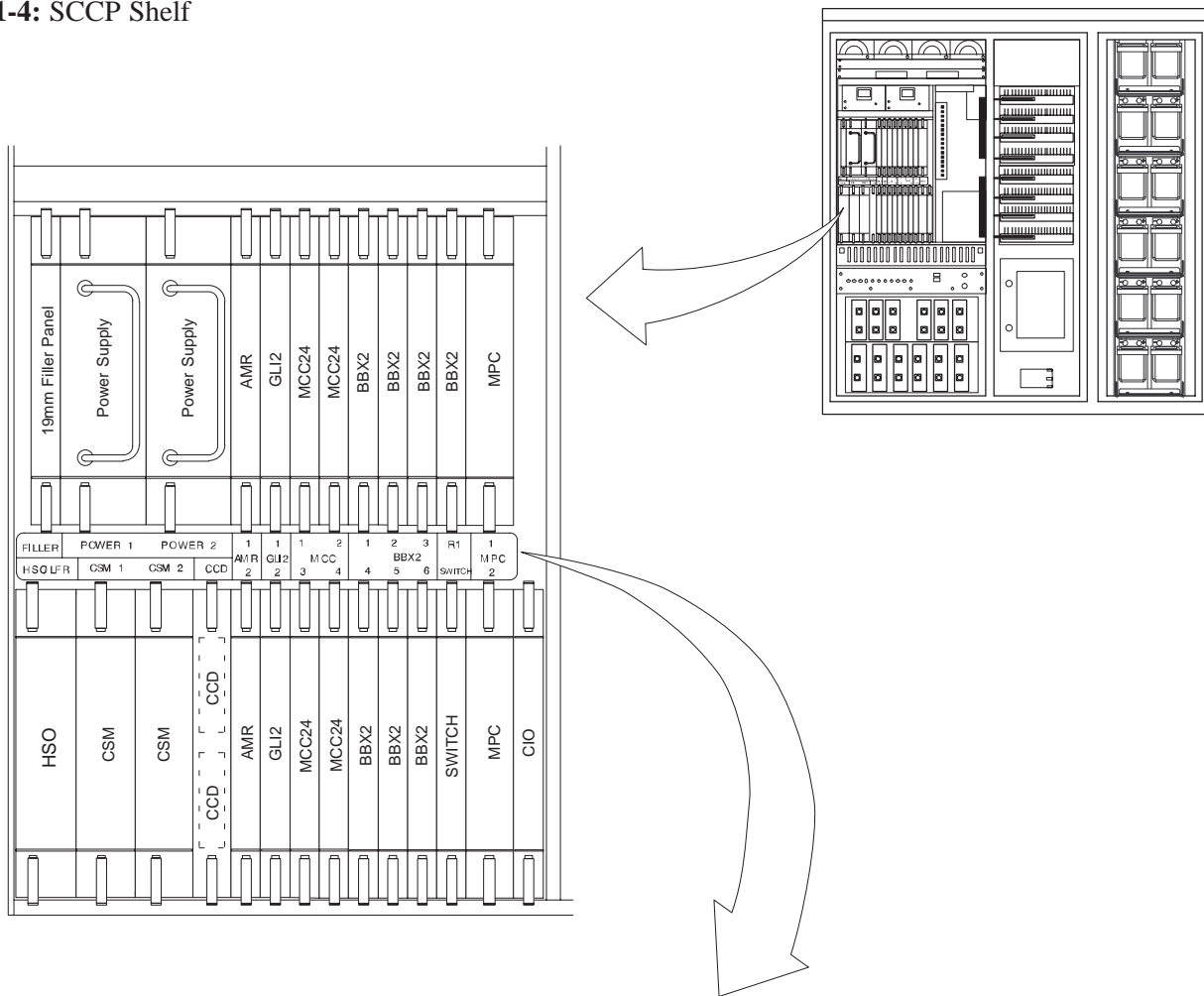

FILLER	POWER 1	POWER 2		1	1	1	2	1	2	3	R1	1
HSO/LFR	CSM 1	CSM 2	CCD	AMR 2	GLI2 2	MCC 3	MCC 4	BBX2 4	BBX2 5	BBX2 6	SWITCH	MPC 2

FRAME 1

FILLER	POWER 1	POWER 2		101	101	101	102	101	102	103	R101	1
HSO/LFR	CSM 101	CSM 102	CCD	AMR 102	GLI2 102	MCC 103	MCC 104	BBX2 104	BBX2 105	BBX2 106	SWITCH	MPC 2

FRAME 101  
(Expansion Frame)

SC4812ETL0003-1

**Punch Block**

The Punch Block is the interface between the cabinet and the T1/E1 span lines, the Customer I/O, alarms, multi-cabinet timing (RGPS and RHSO), and Pilot Beacon control (optional).

**Span I/O Board**

The Span I/O Board provides the interface for the span lines from the CSU to the SCCP backplane (see Figure 1-3).

**RF Diagnostic Subsystem (RFDS)**

The RFDS provides the capability for remotely monitoring the status of the SC4812ETL RF transmit and receive paths (Figure 1-6).

**Heat Exchanger**

The heat exchanger provides cooling to the cabinet RF compartment. The fan speed of the heat exchanger adjusts automatically with temperature. The heat exchanger is located in the cabinet main door.

**SC4812ETL Interface Board (ETIB) and LPA Control (LPAC) Board**

The ETIB is an interconnect module with status LEDs, MMI receptacles, and secondary surge protection for the LPA modules. The LPAC board provides the interface for LPA connections (See Figure 1-3).

**SC4812ETL Trunking Modules**

The trunking modules contain a complex, passive RF network that allows RF signals to share the resources of a bank of four LPAs. They also provides DC power and digital interconnect (See Figure 1-3).

**Batteries**

The batteries provide +24Vdc backup to the cabinet should AC power be lost. The cabinet can accommodate a total of 12 12V batteries, configured in six series-connected strings of two batteries each. The time duration of backup provided depends on system configuration (See Figure 1-3).

**Battery Heaters**

The battery heater pads warm the batteries to provide improved cold-weather performance. A separate heater pad is required for each battery string, and is located between each battery string and its respective support shelf. The number of heaters is dependent on system configuration (See Figure 1-3).

**Rectifiers**

The rectifiers convert AC power supplied to the cabinet to +27Vdc to power the cabinet and maintain the charge of the backup batteries (See Figure 1-3).

### AC Load Center (ACLC)

The ACLC is the cabinet entry point for AC power. It incorporates AC power distribution and surge protection (See Figure 1-3).

Figure 1-5: RF Interface Panel

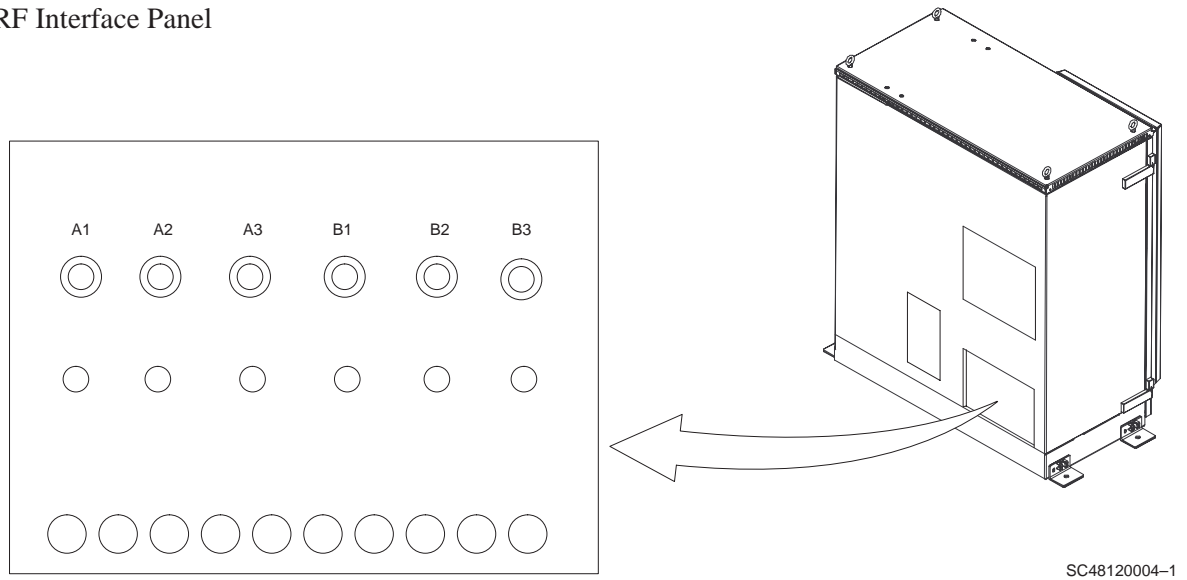
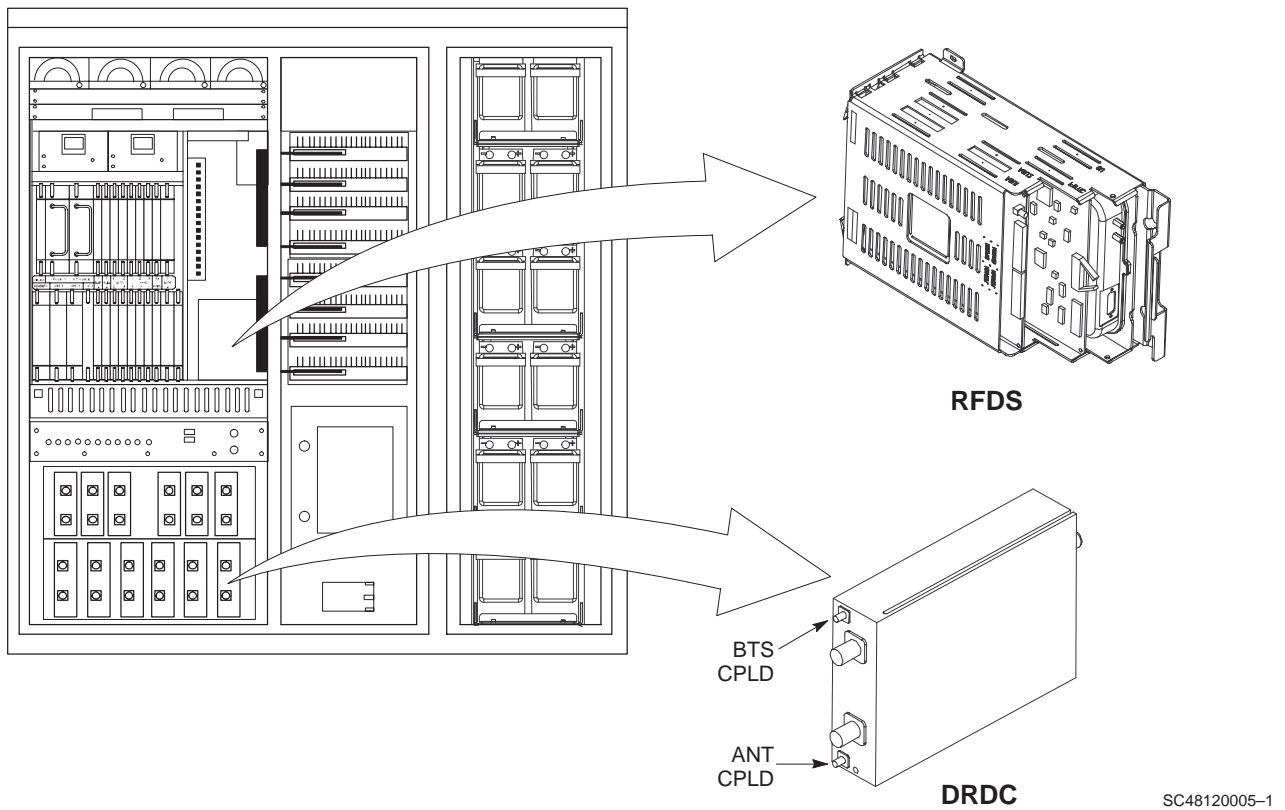

Figure 1-6: RFDS and DRDC Details



# BTS Sector Configurations

## Sector Configuration

There are a number of ways to configure the BTS frame. Table 1-4 outlines the basic requirements. For more detailed information also see Table 1-5 and Figure 1-7. When carrier capacity is greater than two, a 2:1 cavity combiner must be used. For one or two carriers, bandpass filters or cavity combiners may be used, depending on sectorization and channel sequencing.

**Table 1-4: BTS Sector Configuration**

Number of Carriers	Number of Sectors	Channel Spacing	Filter Requirements
1	3	N/A	Bandpass Filter or Cavity Combiner (2:1)
2	3	Non-adjacent	Bandpass Filter, Cavity Combiner (2:1)
2	3	Adjacent	Bandpass Filter (preferred), Cavity Combiner (2:1)

The matrix in Table 1-5 shows a correlation between the various sector configurations and BBX cards.

<b>Table 1-5: Sector Configurations</b>							
<b>Configuration</b>	<b>Description</b>						
<b>1</b>	<b>3-Sector / 1 Carrier</b>						
	The configuration below maps RX and TX with bandpass filters or 2:1 combiners for a 3-sector/1-carrier frame.						
	<b>ANT A1</b>	<b>ANT A2</b>	<b>ANT A3</b>	<b>ANT B1</b>	<b>ANT B2</b>	<b>ANT B3</b>	
	<b>TX1 / RXA1</b>	<b>TX2 / RXA2</b>	<b>TX3 / RXA3</b>	<b>TX4 / RXB1</b>	<b>TX5 / RXB2</b>	<b>TX6 / RXB3</b>	<b>Carrier #</b>
BBX2-1	BBX2-2	BBX2-3	N/A	N/A	N/A	1	
<b>2</b>	<b>3-Sector / 2–NON–ADJACENT Carriers</b>						
	The configuration below maps RX and TX with 2:1 cavity combiners for 3-sectors/2-carriers for <i>non-adjacent</i> channels.						
	<b>ANT A1</b>	<b>ANT A2</b>	<b>ANT A3</b>	<b>ANT B1</b>	<b>ANT B2</b>	<b>ANT B3</b>	
	<b>TX1 / RXA1</b>	<b>TX2 / RXA2</b>	<b>TX3 / RXA3</b>	<b>TX4 / RXB1</b>	<b>TX5 / RXB2</b>	<b>TX6 / RXB3</b>	<b>Carrier #</b>
	BBX2-1	BBX2-2	BBX2-3	N/A	N/A	N/A	1
BBX2-4	BBX2-5	BBX2-6	N/A	N/A	N/A	2	
<b>3</b>	<b>3-Sector / 2–NON–ADJACENT Carriers</b>						
	The configuration below maps RX and TX with bandpass filters for 3-sectors/2-carriers for <i>non-adjacent</i> channels.						
	<b>ANT A1</b>	<b>ANT A2</b>	<b>ANT A3</b>	<b>ANT B1</b>	<b>ANT B2</b>	<b>ANT B3</b>	
	<b>TX1 / RXA1</b>	<b>TX2 / RXA2</b>	<b>TX3 / RXA3</b>	<b>TX4 / RXB1</b>	<b>TX5 / RXB2</b>	<b>TX6 / RXB3</b>	<b>Carrier #</b>
	BBX2-1	BBX2-2	BBX2-3	N/A	N/A	N/A	1
N/A	N/A	N/A	BBX2-4	BBX2-5	BBX2-6	2	
<b>4</b>	<b>3-Sector / 2–ADJACENT Carriers</b>						
	The configuration below maps RX and TX with bandpass filters for 3-sectors/2-carriers for <i>adjacent</i> channels.						
	<b>ANT A1</b>	<b>ANT A2</b>	<b>ANT A3</b>	<b>ANT B1</b>	<b>ANT B2</b>	<b>ANT B3</b>	
	<b>TX1 / RXA1</b>	<b>TX2 / RXA2</b>	<b>TX3 / RXA3</b>	<b>TX4 / RXB1</b>	<b>TX5 / RXB2</b>	<b>TX6 / RXB3</b>	<b>Carrier #</b>
	BBX2-1	BBX2-2	BBX2-3	N/A	N/A	N/A	1
N/A	N/A	N/A	BBX2-4	BBX2-5	BBX2-6	2	
<b>5</b>	<b>3-Sector / 2–ADJACENT Carriers</b>						
	The configuration below maps RX and TX with optional 2:1 cavity combiners for 3-sectors/2-carriers for adjacent channels. Note that <i>dual</i> 2:1 cavity combiners are used (6 total).						
	<b>ANT A1</b>	<b>ANT A2</b>	<b>ANT A3</b>	<b>ANT B1</b>	<b>ANT B2</b>	<b>ANT B3</b>	
	<b>TX1 / RXA1</b>	<b>TX2 / RXA2</b>	<b>TX3 / RXA3</b>	<b>TX4 / RXB1</b>	<b>TX5 / RXB2</b>	<b>TX6 / RXB3</b>	<b>Carrier #</b>
	BBX2-1	BBX2-2	BBX2-3	N/A	N/A	N/A	1
N/A	N/A	N/A	BBX2-4	BBX2-5	BBX2-6	2	

# BTS Sector Configurations – continued

Figure 1-7: SC4812ETL LPA Configuration with Combiners/Filters

**Table 1-5**  
**Configuration Numbers 1, 3, 4**  
**Bandpass Filters**  
**3-Sector**

**Table 1-5**  
**Configuration Numbers 2, 5**  
**2:1 Cavity Combiners**  
**3-Sector**

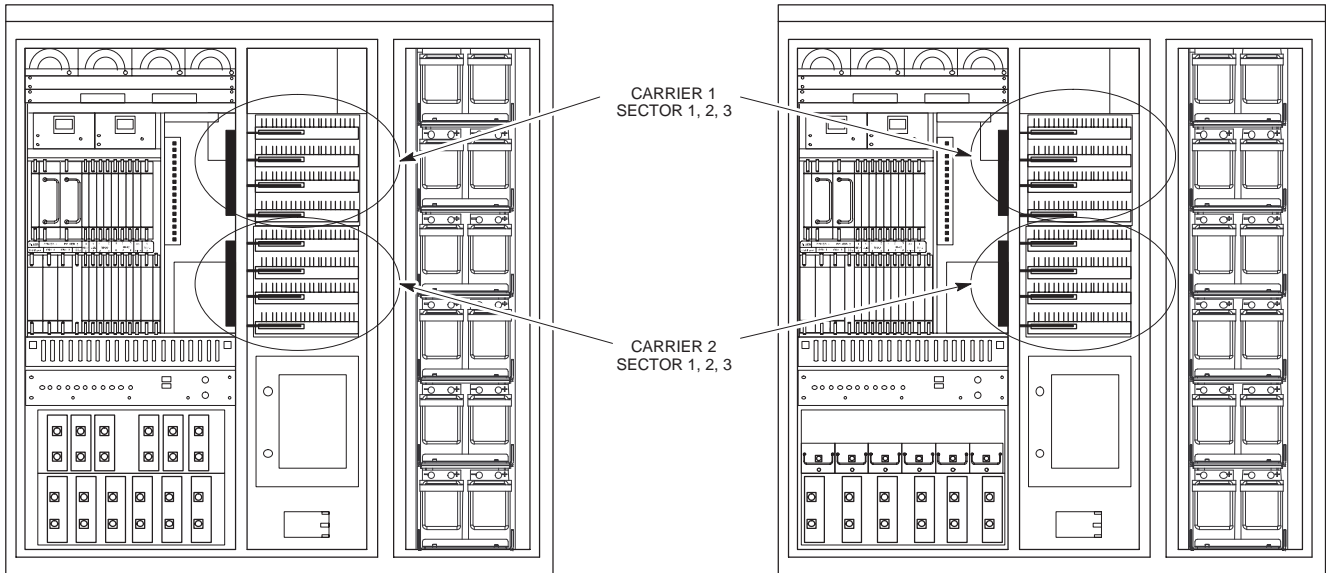

SC4812ETL0011-1

## Chapter 2: Preliminary Operations

### Table of Contents

---

Preliminary Operations: Overview .....	2-1
Introduction .....	2-1
Cell Site Types .....	2-1
CDF .....	2-1
Site Equipage Verification .....	2-1
Initial Installation of Boards/Modules .....	2-1
Setting Frame SCCP Shelf Configuration Switch .....	2-2
Initial Power Up .....	2-3
Introduction .....	2-3
Required Tools .....	2-3
Cabling Inspection .....	2-3
Initial Inspection and Setup .....	2-3
Power-Up Sequence .....	2-4
Power Application Pre-test .....	2-7
Applying AC Power .....	2-9
Power Cabinet Power Up Tests .....	2-10
Battery Charge Test (Connected Batteries) .....	2-11
Battery Discharge Test .....	2-12





# Preliminary Operations: Overview

## Introduction

This section first verifies proper frame equipage. This includes verifying module placement, jumper, and dual in-line package (DIP) switch settings against the site-specific documentation supplied for each BTS application. Next, pre-power up and initial power-up procedures are presented.

## Cellsite Types

Sites are configured as 3-sectored with one or two carriers. Each type has unique characteristics and must be optimized accordingly.

## CDF

The Cell-site Data File (CDF) contains site type and equipage data information and passes it directly to the LMF during optimization. The number of BTS frames, BBX2 and MCC24 boards, and linear power amplifier assignments are some of the equipage data included in the CDF.

## Site Equipage Verification

Review the site documentation. Match the site engineering equipage data to the actual boards and modules shipped to the site. Physically inspect and verify the equipment provided for the BTS or Modem frame and ancillary equipment frame.



### CAUTION

Always wear a conductive, high impedance wrist strap while handling any circuit card/module to prevent damage by ESD. After removal, the card/module should be placed on a conductive surface or back into the anti-static bag it was shipped in.

## Initial Installation of Boards/Modules

**Table 2-1:** Initial Installation of Boards/Modules

Step	Action
1	Refer to the site documentation and slide all boards and modules into the appropriate shelves as required. <b>DO NOT SEAT the boards and modules at this time.</b>
2	As the actual site hardware is installed, record the serial number of each module on a “Serial Number Checklist” in the site logbook.

### Setting Frame SCCP Shelf Configuration Switch

If the frame is a Starter BTS, the backplane switch settings behind the right-hand SCCP shelf fan module should be set to the ON position (see Figure 2-1).

The switch setting must be verified and set before power is applied to the BTS equipment.

Figure 2-1: Backplane DIP Switch Settings

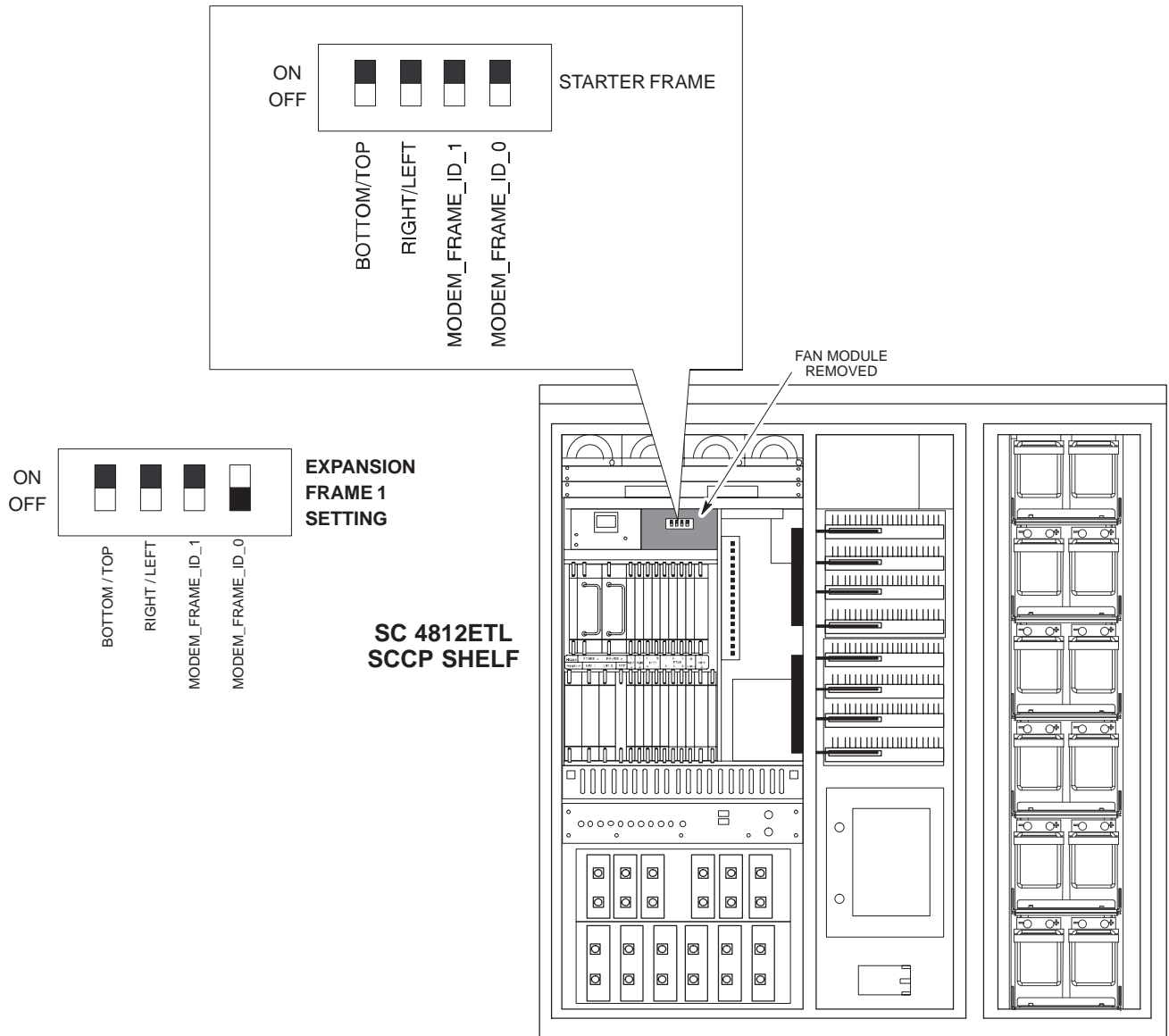

SC4812ETL0006-1

# Initial Power Up

## Introduction

The following information is used to check for any electrical short circuits and to verify the operation and tolerances of the cell site and BTS power supply units before applying power for the first time. It contains instructional information on the proper initial power up procedures for the SC4812ETL. Please pay attention to all cautions and warning statements in order to prevent accidental injury to personnel.

## Required Tools

The following tools are used in the procedures.

- DC current clamp (600 Amp capability with jaw size to accommodate 2/0 cable).
- Hot Air Gun – (optional for part of the Alarm Verification)
- Digital Multimeter (DMM)

## Cabling Inspection

Using the site-specific documentation generated by Motorola Systems Engineering, verify that the following cable systems are properly connected:

- Receive RF cabling – up to six RX cables
- Transmit RF cabling – up to three TX cables



### IMPORTANT

For DC power applications (+27 V):

- The positive power cable is red.
- The negative power cable is black. (The black power cable is at ground potential.)

## Initial Inspection and Setup



### CAUTION

Ensure all battery shelf circuit breakers (Figure 2-3) for unused battery positions are off (pulled out) before and during the entire power up process. Leave these breakers in the off position when leaving the site.

**Table 2-2: Initial Inspection and Setup**

Step	Action
1	Verify that ALL AC Load Center (ACLC) and DC Power Distribution Assembly (PDA) circuit breakers are turned <b>OFF</b> .
2	Confirm that the external 220 Vac supply is correctly connected to the ACLC input.



### CAUTION

Failure to properly connect the external AC power cable will damage the surge protection module inside the AC load center.

## Power-Up Sequence

The first task in the power-up sequence is to apply external AC power to the cabinet. Once power is applied, a series of AC Voltage measurements is required.

**Table 2-3: AC Voltage Measurements**

Step	Action
1	Gain access to the ACLC external power connection terminals from the rear of the cabinet by opening the power entry compartment access door and removing the ACLC rear cover (see Figure 2-2).
2	Measure the AC voltage from terminal L1 to neutral. Voltage should be in the nominal range of 115 to 120 Vac.
3	Measure the AC voltage from terminal L1 to ground. Voltage should be in the nominal range of 115 to 120 Vac.
4	Measure the AC voltage from terminal L2 to neutral. Voltage should be in the nominal range of 115 to 120 Vac.
5	Measure the AC voltage from terminal L2 to ground. Voltage should be in the nominal range of 115 to 120 Vac.
6	Measure L1 – L2 – should be from 208 to 240 Vac.



### CAUTION

If the AC voltages are in excess of 120 V (or exceed 200 V) when measuring between terminals L1 or L2 to neutral or ground, **STOP** and DO NOT proceed until the cause of the higher voltages are determined. The cabinet **WILL** be damaged if the Main breaker is turned on with excessive voltage on the inputs.

# Initial Power Up – continued

Figure 2-2: AC Load Center External Power Connections

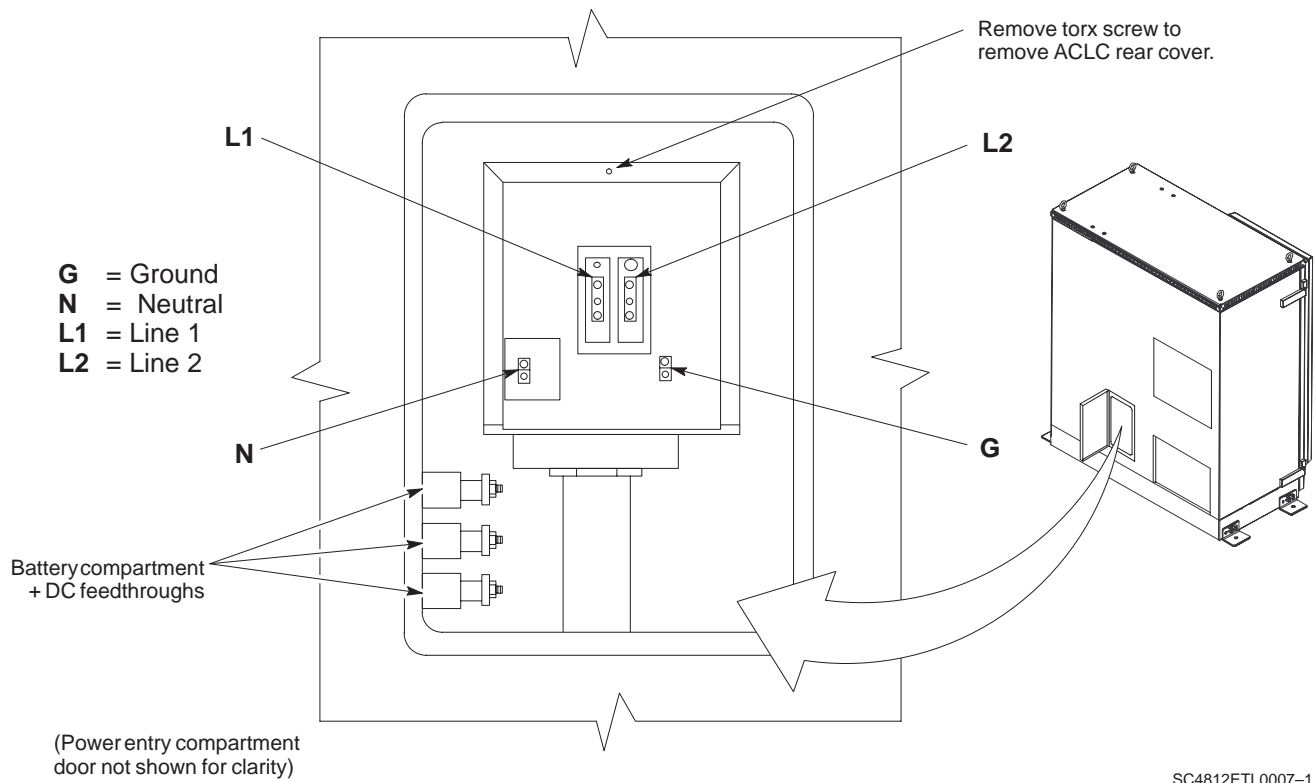
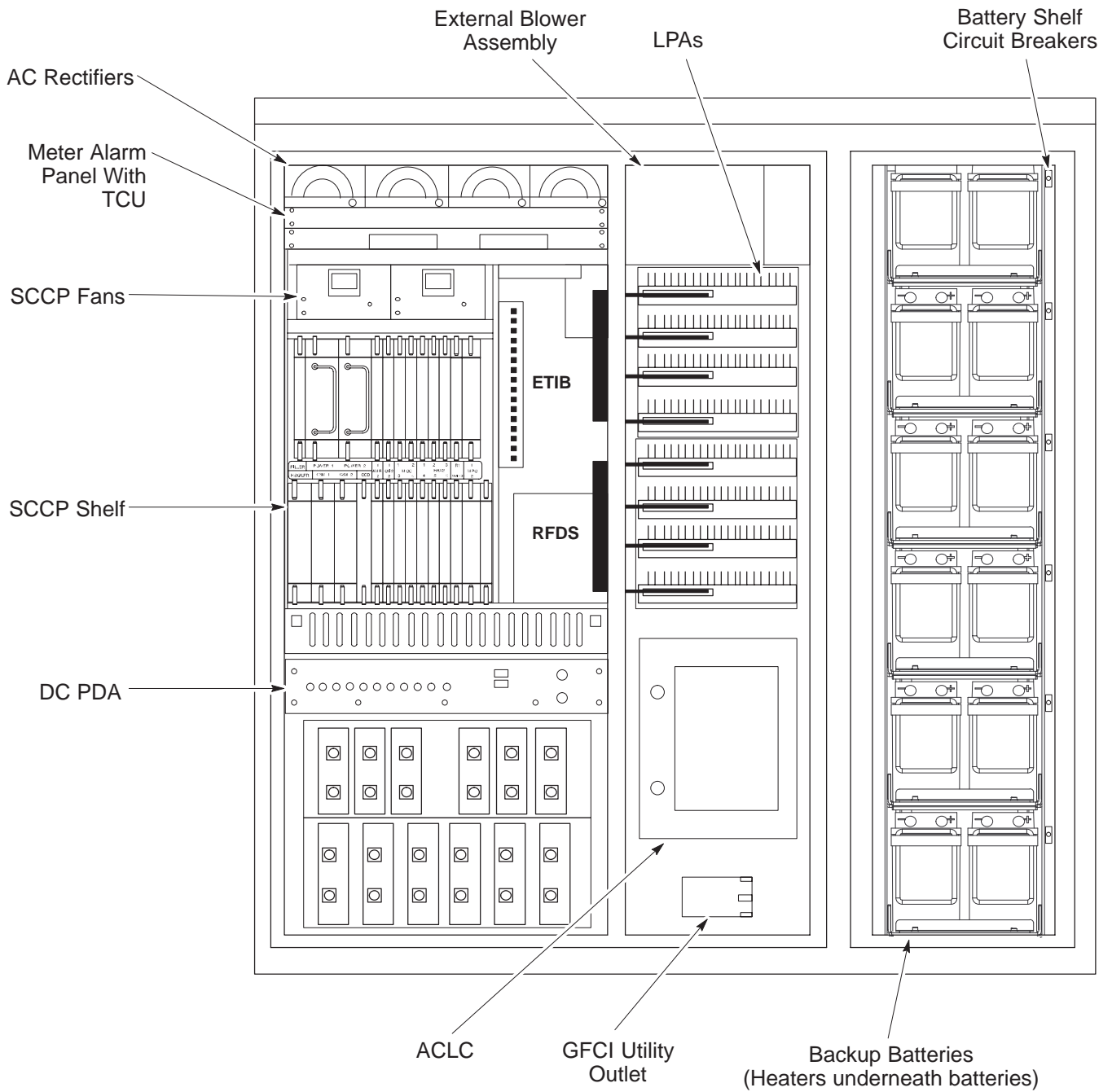

Figure 2-3: Cabinet Power Subassemblies



SC4812ETL0002-2

## Initial Power Up – continued

**Figure 2-4:** ACLC Circuit Breaker Panel

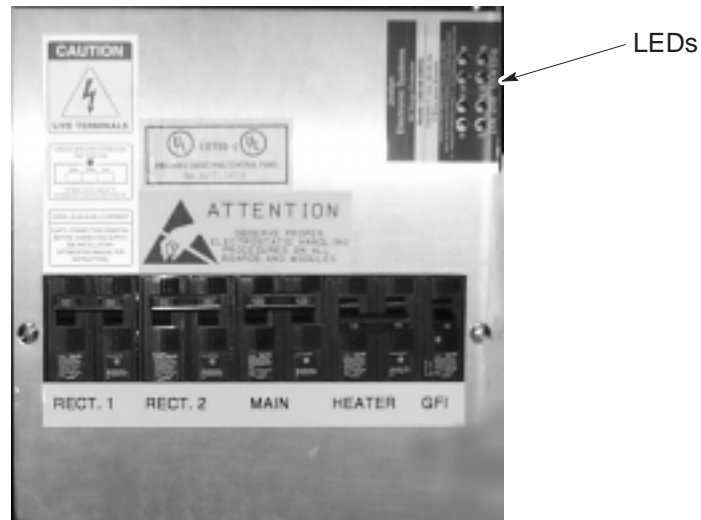

SC4812ETL0008-1

**Figure 2-5:** DC Power Distribution Assembly



SC4812ETL0009-1

### Power Application Pre-test

Before applying any power to the BTS cabinet, follow the procedure in Table 2-4 to verify there are no shorts in the DC power distribution system.

#### NOTE

The following procedure is required only on initial BTS power-up or following maintenance when any major power components (e.g., DC PDA, ACLC) were replaced or DC power cables were disconnected.



**Table 2-4:** Pre-power DC Power Distribution System Test

Step	Action
1	<i>Physically verify</i> that circuit breakers on the ACLC (Figure 2-4) and DC PDA (figure Figure 2-5), and <i>all</i> battery shelf circuit breakers (Figure 2-3), are <b>OFF</b> .
2	Visually ensure that all AC rectifier modules (Figure 2-3) are <i>not</i> powered (DC, Power, and bar graph LEDs <i>are not lighted</i> ).
3	Inside the battery compartment, measure the <i>voltage</i> between the + (red) and – (black) battery bus bars. There should be no 27 Vdc present.
4	<i>In the cabinet RF and LPA compartments</i> , unseat all circuit boards/ modules (except CCD and CIO cards) in the SCCP shelf and Linear Power Amplifier (LPA) shelves, but leave them in their respective slots.
5	Inside the battery compartment, measure the resistance between the + (red) and – (black) battery bus bars. Verify that the resistance measures $\geq 500 \Omega$ . <ul style="list-style-type: none"> <li>• If reading is <math>&lt; 500 \Omega</math>, a short may exist somewhere in the DC distribution path supplied by the breaker. Isolate the problem before proceeding. A reading <math>&gt; 3 M\Omega</math> could indicate an open (or missing) bleeder resistor (installed across the filter capacitors behind the breaker panel).</li> </ul>
6	On the DC PDA, set the Main Breaker #1 (Internal) to the <b>ON</b> position by pushing it in, and repeat step 5. <p><b>* IMPORTANT</b></p> If, after inserting any board/module, the ohmmeter stays at $0 \Omega$ , a short probably exists in that board/module. Replace the suspect board/module and repeat the test. If test still fails, isolate the problem before proceeding.
7	Repeat step 6 for Main Breaker #2, and each LPA circuit breaker.
8	<p><b>! CAUTION</b></p> Verify the correct power/converter modules by observing the locking/retracting tabs appear as follows: –  (in +27 volt systems) Insert and lock the PS1 DC–DC converter module into its slot, and repeat step 5. <ul style="list-style-type: none"> <li>• A typical response is that the ohmmeter will steadily climb in resistance as capacitors charge, finally indicating approximately <math>500 \Omega</math>.</li> </ul>
9	Repeat step 8 for the PS2 converter module and all remaining modules in the SCCP shelf.
10	On the DC PDA, set the LPA 1A–1B circuit breaker to the <b>ON</b> position <i>by pushing it in</i> , and repeat step 5.
11	Repeat step 10 for each of the three remaining LPA circuit breakers.
12	Seat all LPAs into their respective slots in the shelves <i>one at a time</i> . Repeat step 5 after seating each LPA. <ul style="list-style-type: none"> <li>• A typical response is that the ohmmeter will steadily climb in resistance as capacitors charge, stopping at approximately <math>500 \Omega</math>.</li> </ul>

... continued on next page



## Initial Power Up – continued

**Table 2-4:** Pre-power DC Power Distribution System Test

Step	Action
13	Seat the Pilot Beacon, Heat Exchanger, ETIB, and Options circuit breakers to <b>ON</b> <i>one at a time</i> . Repeat step 5 after pushing in each circuit breaker.
14	Set all DC PDA circuit breakers to <b>OFF</b> (pulled out).

## Applying AC Power

Once AC voltage measurements are complete, apply AC power to the Power Cabinet. Table 2-5 provides the procedure for applying AC power.

**Table 2-5:** Applying AC Power

Step	Action
1	After cabinet AC input voltages are verified as correct, turn the Main AC breaker (located on the front of the AC Load Center) <b>ON</b> . Observe that all eight (8) green LEDs on the front of the ACLC are illuminated (see Figure 2-4).
2	On the ACLC, Turn RECT. 1 and RECT. 2 AC branch breakers <b>ON</b> . All the installed rectifier modules (see Figure 2-3) will start up, and the green DC and PWR LEDs should light on each.
3	Turn the Meter Alarm Panel module, <b>ON</b> (see Figure 2-6). The Meter Alarm Panel voltage meter should read approximately $27.4 \pm 0.2$ VDC.
4	Turn the Temperature Compensation Panel (TCP) <b>ON</b> , (see Figure 2-7). Verify that the Meter Alarm Control Panel does not have any alarm LEDs illuminated.
5	Check the rectifier current bargraph displays (green LED display on the rectifier module). None should be illuminated at this point.

### NOTE

If batteries are fitted, turn on the two battery heater AC breakers on the AC Load Center.

**Figure 2-6:** Meter Alarm Panel

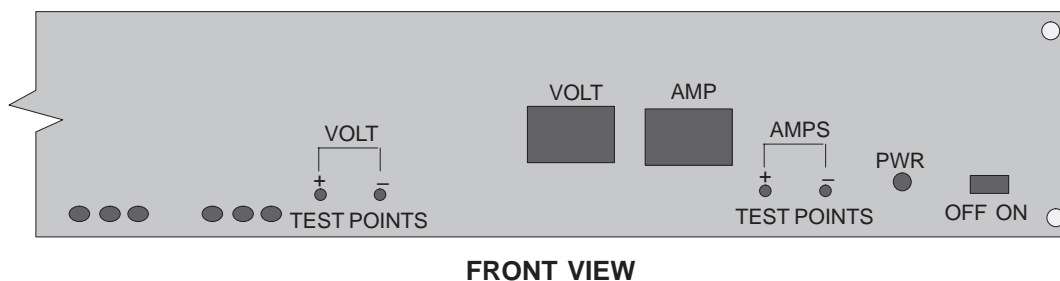
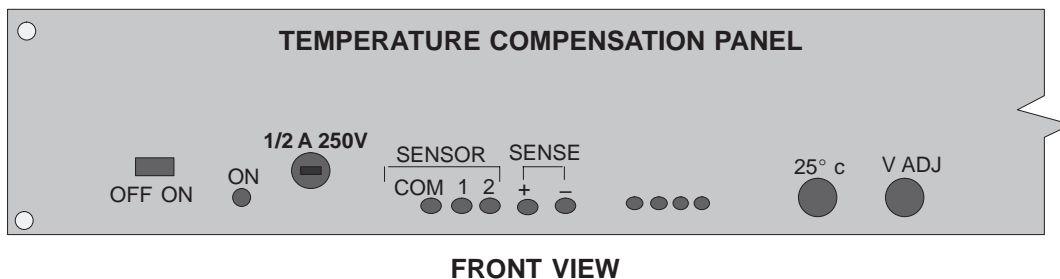

Figure 2-7: Temperature Compensation Panel



**Power Cabinet Power Up Tests**

Table 2-6 lists the step-by-step instructions for Power Up Tests.

<b>Table 2-6: Cabinet DC Power-Up Tests</b>	
<b>Step</b>	<b>Action</b>
1	Ensure <i>ALL</i> DC PDA circuit breakers are <b>OFF</b> (pulled out).
2	Be sure the procedures in Table 2-4 (if required) and (Table 2-5) have been performed.
3	Probe the VOLT TEST POINTS on the Meter Alarm Panel while pressing the 25° C set button on the TCP (see Figure 2-7). The voltage should read $27.4 \pm 0.2$ VDC. Adjust Master Voltage on Meter Alarm Panel if necessary. Release the TCP 25° C set button.
4	Depending on the ambient temperature, the voltage reading may now change by up to $\pm 1.5$ V compared to the reading just measured. If it is cooler than 25°C, the voltage will be higher, and if it is warmer than 25°C, the voltage will be lower.
5	If the BTS is equipped with a internal backup batteries, close (push in) DC PDA Main Breaker #1 (Internal) and proceed to step 7.
6	If the BTS is connected to an external BOE containing backup batteries, close (push in) DC PDA Main Breaker #2 (External).
7	Inside the power entry compartment at the rear of the cabinet, measure the voltage between the + (red) terminals of the filtered DC battery compartment feedthrough (Figure 2-2) and chassis ground, observing that the polarity is correct. The voltage should be the same as the measurement in step 2.
8	Measure the voltage between the + (red) and – (black) battery bus bars in the battery compartment. Place the probe at the bottom of the bus bars where the cables are connected. The DC voltage should measure the same as the previous step.
9	<p><i>On the DC PDA(see Figure 2-5) set the circuit breakers to the <b>ON</b> position by pushing them in one at a time in the following sequence:</i></p> <ul style="list-style-type: none"> <li>• PS1 and PS2 circuit breakers</li> <li>• LPA circuit breakers (four breakers, labeled <b>1A–1B</b> through <b>2C–2D</b>).</li> <li>• HEAT EXCHANGER circuit breakers (two breakers)</li> <li>• ETIB circuit breaker</li> <li>• PILOT BEACON circuit breaker</li> <li>• OPTION circuit breaker</li> </ul>

**Battery Charge Test  
(Connected Batteries)**

Table 2-7 lists the step-by-step instructions for testing the batteries.



<b>Table 2-7: Battery Charge Test (Connected Batteries)</b>	
<b>Step</b>	<b>Action</b>
1	<p>Close the battery shelf circuit breakers (Figure 2-3) for connected batteries ONLY. This process should be completed quickly to avoid individual battery strings with excess charge current</p> <p><b>NOTE</b></p> <p>If the batteries are sufficiently discharged, the battery circuit breakers may not engage individually due to the surge current. If this condition is observed, turn off the Meter Alarm Panel power switch, and then engage all the connected battery circuit breakers, the Meter Alarm Panel power switch should then be turned ON.</p>
2	<p>Using the DC current probe, measure the current in each of the battery string connections to the battery cabinet bus bars. The charge current may initially be high but should quickly reduce in a few minutes if the batteries have a typical new battery charge level.</p> <p><b>NOTE</b></p> <p>The bar graph meters on the AC rectifier modules can be used as a rough estimate of the total battery charge current. Each rectifier module bar graph has eight (8) LEDs to represent the output current. Each illuminated LED indicates that approximately 12.5% (1/8 or 8.75 Amps) of the rectifiers maximum (70 Amps) current is flowing.</p> <p><b>EXAMPLE:</b></p> <p><b>Question:</b> A system fitted with three (3) rectifier modules each have three bargraph LEDs illuminated. What is the total output current into the batteries?</p> <p><b>Answer:</b> Each bargraph is approximately indicating 12.5% of 70 Amps, therefore, 3 X 8.75 equals 26.25 Amps. As there are three rectifiers, the total charge current is equal to (3 X 26.25 A) 78.75 Amps.</p> <p>This charge current calculation only applies at this part of the start up procedure, when the RF Cabinet is not powered on, and the power cabinet heat exchanger is turned off.</p>
3	The current in each string should be approximately equal ( $\pm 5$ amps).
4	Allow a few minutes to ensure that the battery charge current stabilizes before taking any further action. Recheck the battery current in each string. If the batteries had a reasonable charge, the current in each string should reduce to less than 5A.
5	<p>Recheck the DC output voltage. It should remain the same as measured in step 4 of the Power Up Test.</p> <p><b>NOTE</b></p> <p>If discharged batteries are installed, all bargraphs may be illuminated on the rectifiers during the charge test. This indicates that the rectifiers are at full capacity and are rapidly charging the batteries. It is recommended in this case that the batteries are allowed to charge and stabilize as in the above step before commissioning the site. This could take several hours.</p>

## Battery Discharge Test

Perform the test procedure in Table 2-8 only when the battery current is less than 5 A per string. Refer to Table 2-7 on the procedures for checking current levels.

**Table 2-8: Battery Discharge Test**

Step	Action
1	Turn the battery test switch on the Meter Alarm Panel, ON (see Figure 2-6). The rectifier output voltage and current should decrease by approximately 10% as the batteries assume the load. Alarms for the Meter Alarm Panel may occur.
2	Measure the individual battery string current using the DC current probe. The battery discharge current in each string should be approximately the same (within $\pm 5$ A).
3	Turn Battery Test Switch <b>OFF</b> .



### CAUTION

Failure to turn OFF the Battery Test Switch before leaving the site will result in low battery capacity and reduce battery life.

Figure 2-8: Heat Exchanger Blower Assembly and Circuit Breakers

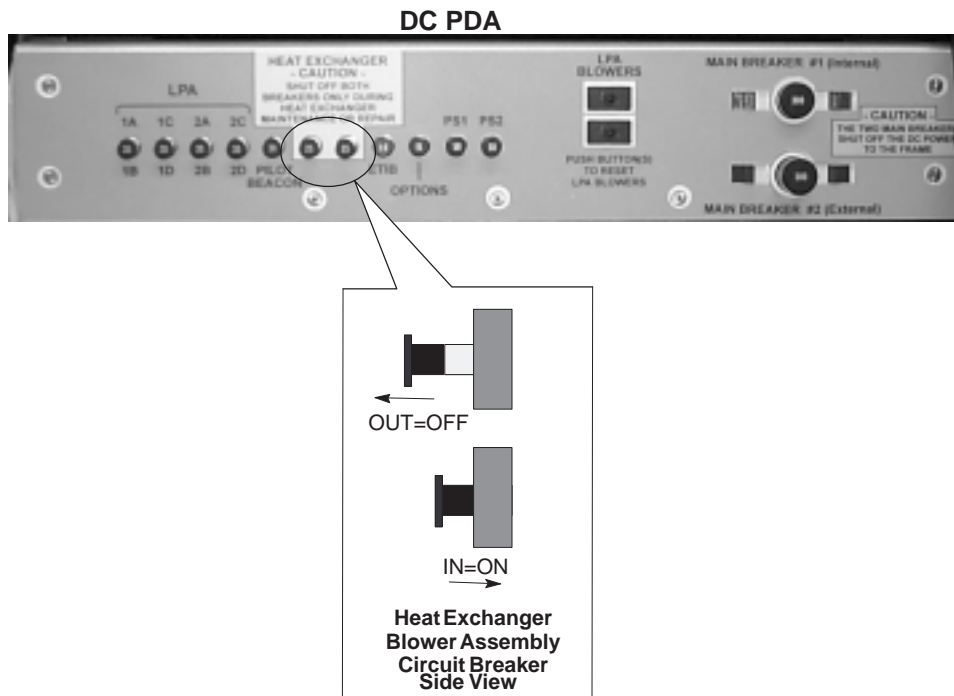
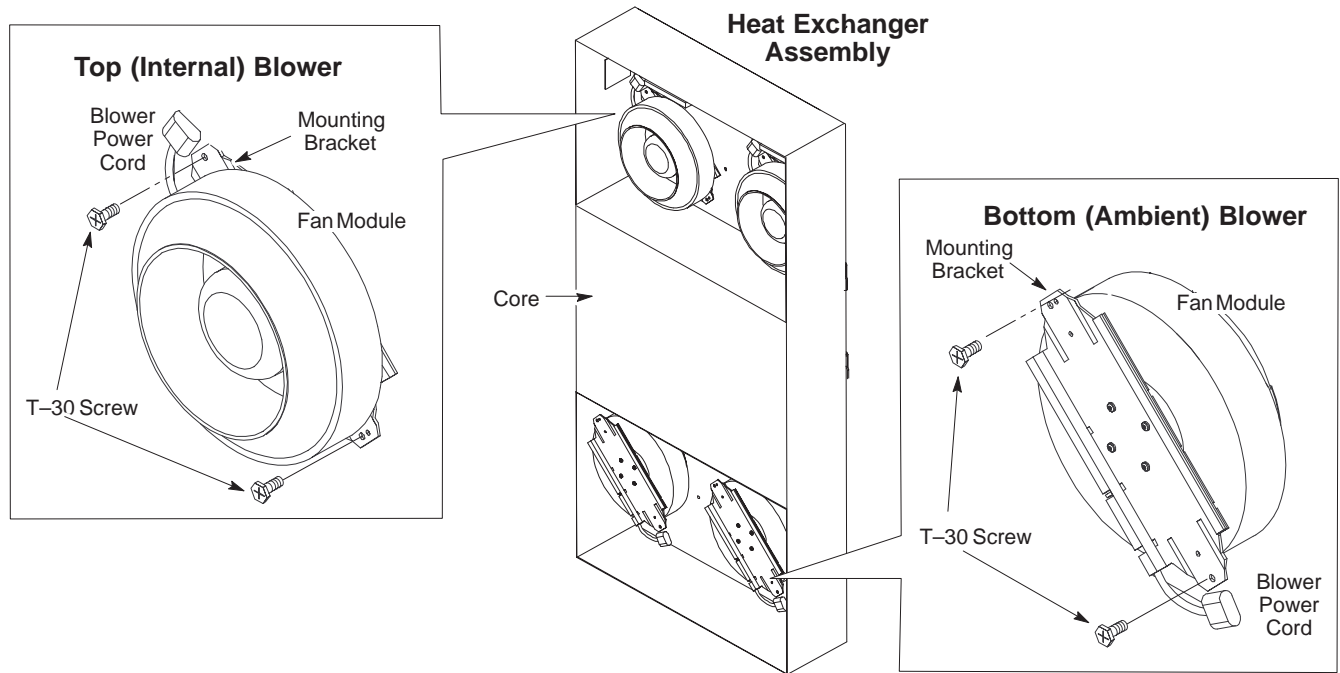



## Chapter 3: Optimization/Calibration

### Table of Contents

---

Optimization/Calibration – Introduction .....	3-1
Introduction .....	3-1
Optimization Process .....	3-1
Cell Site Types .....	3-2
Cell Site Data File (CDF) .....	3-2
BTS System Software Download .....	3-3
Site Equipage Verification .....	3-3
Isolate Span Lines/Connect LMF .....	3-4
Isolate BTS from T1/E1 Spans .....	3-4
Configure Channel Service Unit .....	3-4
Alarm and Span Line Cable Pin/Signal Information .....	3-6
T1/E1 Span Isolation .....	3-8
Preparing the LMF .....	3-9
Overview .....	3-9
LMF Installation and Update Procedures .....	3-9
Copy CBSC CDF Files to the LMF Computer .....	3-10
Creating a Named HyperTerminal Connection for MMI Communication .....	3-12
Folder Structure Overview .....	3-14
wlmf Folder .....	3-14
cdma Folder .....	3-14
bts–nnn Folders .....	3-14
bts–nnn.cal File .....	3-15
bts–nnn.cdf File .....	3-15
cbsc File .....	3-16
loads Folder .....	3-16
version Folder .....	3-16
code Folder .....	3-16
data Folder .....	3-17
LMF to BTS Connection .....	3-19
LMF to BTS Connection .....	3-19
Using CDMA LMF .....	3-20
Basic CDMA LMF Operation .....	3-20
Logging Into a BTS .....	3-20
Logging Out .....	3-23
Establishing an MMI Communication Session .....	3-25

---

## Table of Contents – continued

Online Help .....	3-26
Pinging the Processors .....	3-27
Pinging the BTS .....	3-27
Download the BTS .....	3-29
Overview .....	3-29
Download RAM Code and Data to MGLI and GLI .....	3-31
Download RAM Code and Data to Non-GLI Devices .....	3-32
Select CSM Clock Source .....	3-33
Enable CSMs .....	3-33
Enable MCCs .....	3-34
CSM System Time – GPS & LFR/HSO Verification .....	3-36
Clock Synchronization Manager (CSM) System Time .....	3-36
Low Frequency Receiver/ High Stability Oscillator .....	3-36
CSM Frequency Verification .....	3-38
Test Equipment Setup (GPS & LFR/HSO Verification) .....	3-38
GPS Initialization/Verification .....	3-39
LORAN-C Initialization/Verification .....	3-44
Test Equipment Setup .....	3-46
Connecting Test Equipment to the BTS .....	3-46
Equipment Warm-up .....	3-48
Test Set Calibration .....	3-54
Background .....	3-54
Purpose .....	3-54
Selecting Test Equipment .....	3-55
Manually Selecting Test Equipment in a Serial Connection Tab .....	3-55
Automatically Selecting Test Equipment in a Serial Connection Tab ..	3-56
Calibrating Test Equipment .....	3-57
Calibrating Cables .....	3-57
Calibrating Cables with a CDMA Analyzer .....	3-58
Calibrating TX Cables Using a Signal Generator and Spectrum Analyzer .....	3-59
Calibrating RX Cables Using a Signal Generator and Spectrum Analyzer .....	3-60
Setting Cable Loss Values .....	3-61
Setting TX Coupler Loss Value .....	3-62
Bay Level Offset Calibration .....	3-63
Introduction .....	3-63
RF Path Bay Level Offset Calibration .....	3-63
When to Calibrate BLOs .....	3-63
TX Path Calibration .....	3-64
BLO Calibration Data File .....	3-65
Test Equipment Setup: RF Path Calibration .....	3-67
Transmit (TX) Path Calibration .....	3-67
Download BLO Procedure .....	3-69
Calibration Audit Introduction .....	3-71



---

## Table of Contents – continued

Transmit (TX) Path Audit .....	3-71
TX Audit Test .....	3-72
All Cal/Audit Test .....	3-73
Create CAL File .....	3-74
RFDS Setup and Calibration .....	3-75
RFDS Description .....	3-75
RFDS Parameter Settings .....	3-75
RFDS TSU NAM Programming .....	3-77
Explanation of Parameters used when Programming the TSU NAM ..	3-77
Valid NAM Ranges .....	3-78
Set Antenna Map Data .....	3-79
Set RFDS Configuration Data .....	3-80
RFDS Calibration .....	3-81
Program TSU NAM .....	3-83
Alarms Testing .....	3-84
Alarm Verification .....	3-84
Alarm Reporting Display .....	3-84
Heat Exchanger Alarm Test .....	3-85
Door Alarm .....	3-85
AC Fail Alarm .....	3-85
Minor Alarm .....	3-86
Rectifier Alarms .....	3-86
Single Rectifier Failure (Three Rectifier System) .....	3-86
Multiple Rectifier Failure .....	3-86
Single Rectifier Failure (Six Rectifier System) .....	3-87
Multiple Rectifier Failure (Six Rectifier System) .....	3-87
Battery Over Temperature Alarm (Optional) .....	3-88
Rectifier Over Temperature Alarm .....	3-90
Before Leaving the site .....	3-91



## Introduction

This chapter provides procedures for downloading system operating software, set up of the supported test equipment, CSM reference verification/optimization, and transmit/receive path verification.



### IMPORTANT

Before using the LMF, use an editor to view the "CAVEATS" section in the "readme.txt" file in the c:\wlmf folder for any applicable information.

## Optimization Process

After a BTS is physically installed and the preliminary operations (power up) have been completed, the CDMA LMF is used to calibrate and optimize the BTS. The basic optimization process can be accomplished as follows:

- Download MGLI2-1 with code and data and then enable MGLI2-1.
- Use the status function and verify that all of the installed devices of the following types respond with status information: CSM2, BBX2, GLI2, and MCC (and TSU if RFDS is installed). If a device is installed and powered up but is not responding and is colored gray in the BTS display, the device is not listed in the CDF file. The CDF file will have to be corrected before the device can be accessed by CDMA LMF.
- Download code and data to all devices of the following types:
  - CSM2
  - BBX2
  - GLI2 (other than MGLI2-1)
  - MCC
- Download the RFDS TSIC (if installed).
- Verify the operation of the GPS and HSO signals.
- Enable the following devices (in the order listed):
  - Secondary CSM (slot 2)
  - Primary CSM (slot 1)
  - All MCCs
- Connect the required test equipment for a full optimization.
- Select the test equipment.
- Calibrate the TX and RX test cables if they have not previously been calibrated using the CDMA LMF that is going to be used for the optimization/calibration. The cable calibration values can also be entered manually.
- Select all of the BBXs and all of the MCCs and use the full optimization function. The full optimization function performs TX

calibration, BLO download, TX audit, all TX tests, and all RX tests for all selected devices.

- If the TX calibration fails, repeat the full optimization for any failed paths.
- If the TX calibration fails again, correct the problem that caused the failure and repeat the full optimization for the failed path.
- If the TX calibration and audit portion of the full optimization passes for a path but some of the TX or RX tests fail, correct the problem that caused the failure and run the individual tests as required until all TX and RX tests have passed for all paths.

### Cell Site Types

Sites are configured as Omni/Omni or Sector/Sector (TX/RX). Each type has unique characteristics and must be optimized accordingly.

### Cell Site Data File (CDF)

The CDF includes the following information:

- Download instructions and protocol
- Site specific equipage information
- C–CCP shelf allocation plan
  - BBX2 equipage (based on cell–site type) including redundancy
  - CSM equipage including redundancy
  - Multi Channel Card 24 (MCC24 or MCC8E) channel element allocation plan. This plan indicates how the C–CCP shelf is configured, and how the paging, synchronization, traffic, and access channel elements (and associated gain values) are assigned among the (up to 12) MCC24s or MCC8Es in the shelf.
- CSM equipage including redundancy
- Effective Rated Power (ERP) table for all TX channels to antennas respectively. Motorola System Engineering specifies the ERP of a transmit antenna based on site geography, antenna placement, and government regulations. Working from this ERP requirement, the antenna gain, (dependent on the units of measurement specified) and antenna feed line loss can be combined to determine the required power at the top of the BTS frame. The corresponding BBX2 output level required to achieve that power level on any channel/sector can also be determined.

#### NOTE

Refer to the *CDMA LMF Operator's Guide, 68P64114A21*, for additional information on the layout of the LMF directory structure (including CDF file locations and formats).

### BTS System Software Download

BTS system software must be successfully downloaded to the BTS processor boards before optimization can be performed. BTS operating code is loaded from the LMF computer terminal.



#### IMPORTANT

Before using the LMF for optimization/ATP, the correct **bts-#.cdf** and **cbse-#.cdf** files for the BTS must be obtained from the CBSC and put in a **bts-#** folder in the LMF. Failure to use the correct CDF files can cause wrong results. **Failure to use the correct CDF files to log into a live (traffic carrying) site can shut down the site.**

3

The CDF is normally obtained from the CBSC on a DOS formatted diskette, or through a file transfer protocol (ftp) if the LMF computer has ftp capability. Refer to the *CDMA LMF Operator's Guide*, 68P64114A21, or the LMF Help screen, for more information.

### Site Equipage Verification

If you have not already done so, use an editor to view the CDF, and review the site documentation. Verify the site engineering equipage data in the CDF to the actual site hardware.



#### CAUTION

Always wear a conductive, high impedance wrist strap while handling any circuit card/module to prevent damage by ESD. Extreme care should be taken during the removal and installation of any card/module. After removal, the card/module should be placed on a conductive surface or back into the anti-static bag in which it was shipped.

---

## Span Lines – Interface and Isolation

### Isolate BTS from T1/E1 Spans



#### IMPORTANT

**At active sites**, the OMC/CBSC must disable the BTS and place it out of service (OOS). **DO NOT** remove the span surge protectors until the OMC/CBSC has disabled the BTS.

Each frame is equipped with one 50 pair punch block for spans, customer alarms, remote GPS, and power cabinet alarms. See Figure 3-2 and refer to Table 3-1 for the physical location and pin call-out information. To disable the span, pull the surge protectors for the respective span.

Before connecting the LMF to the frame LAN, the OMC/CBSC must disable the BTS and place it OOS to allow the LMF to control the BTS. This prevents the CBSC from inadvertently sending control information to the BTS during LMF based tests.

### Configure Channel Service Unit

The M-PATH 537 channel service unit (CSU) provides in-band SNMP-managed digital service access to T1 and fractional T1 lines. M-PATH units plug into the ADC Kentrox 2-slot frame (see Figure 3-1).

Remote M-PATH management is available via SNMP over an in-band data link on the T1 line (using a facility data link or 8–64 Kbps of a DS0 channel). The unit at the near end of the management path can be an SNMP manager or another M-PATH CSU.

Each 19 inch rack can support two CSU M-PATH 537 modules. Each M-PATH 537 module supports a single span connection.

Programming of the M-PATH is accomplished through the DCE 9-pin connector on the front panel of the CSU shelf. Manuals and a Microsoft Windows programming disk is supplied with each unit.

### Setting the Control Port

Whichever control port is chosen, it must first be set up so the control port switches match the communication parameters being used by the control device. If using the rear-panel DTE control port, set the shelf-address switch SA5 to “up” (leave the switch down for the rear-panel DCE control port).

For more information, refer to the Kentrox Installation Guide, manual number 65-77538001 which is provided with each CSU.

Plug one of the cables listed below into the Control Port connectors:

<u>Part Number</u>	<u>Description of Cable</u>
01-95006-022 (six feet)	DB-9S to DB-9P
01-95010-022 (ten feet)	

The control port cables can be used to connect the shelf to:

- A PC using the AT 9-pin interface
- A modem using the 9-pin connector
- Other shelves in a daisy chain

Figure 3-1: Back and Front View of the CSU

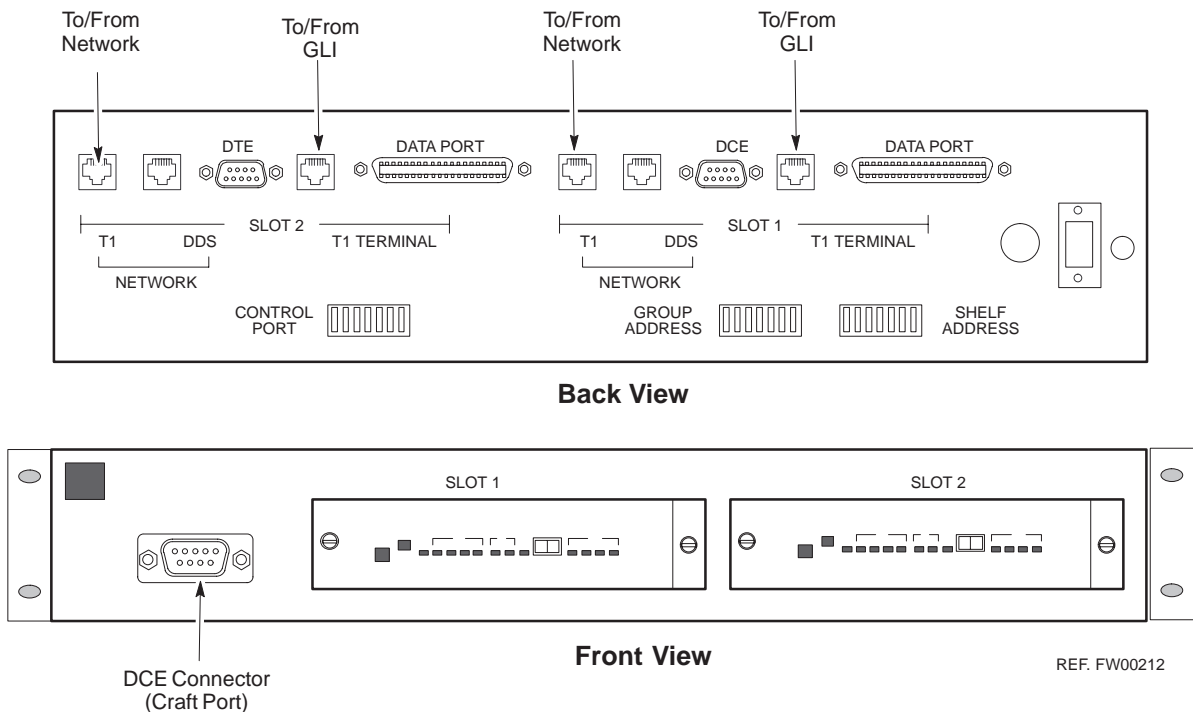

REF. FW00212

**Alarm and Span Line Cable  
Pin/Signal Information**

See Figure 3-2 and refer to Table 3-1 for the physical location and pin call-out information for the 50-pin punch block.

**Figure 3-2: 50 Pair Punch Block**

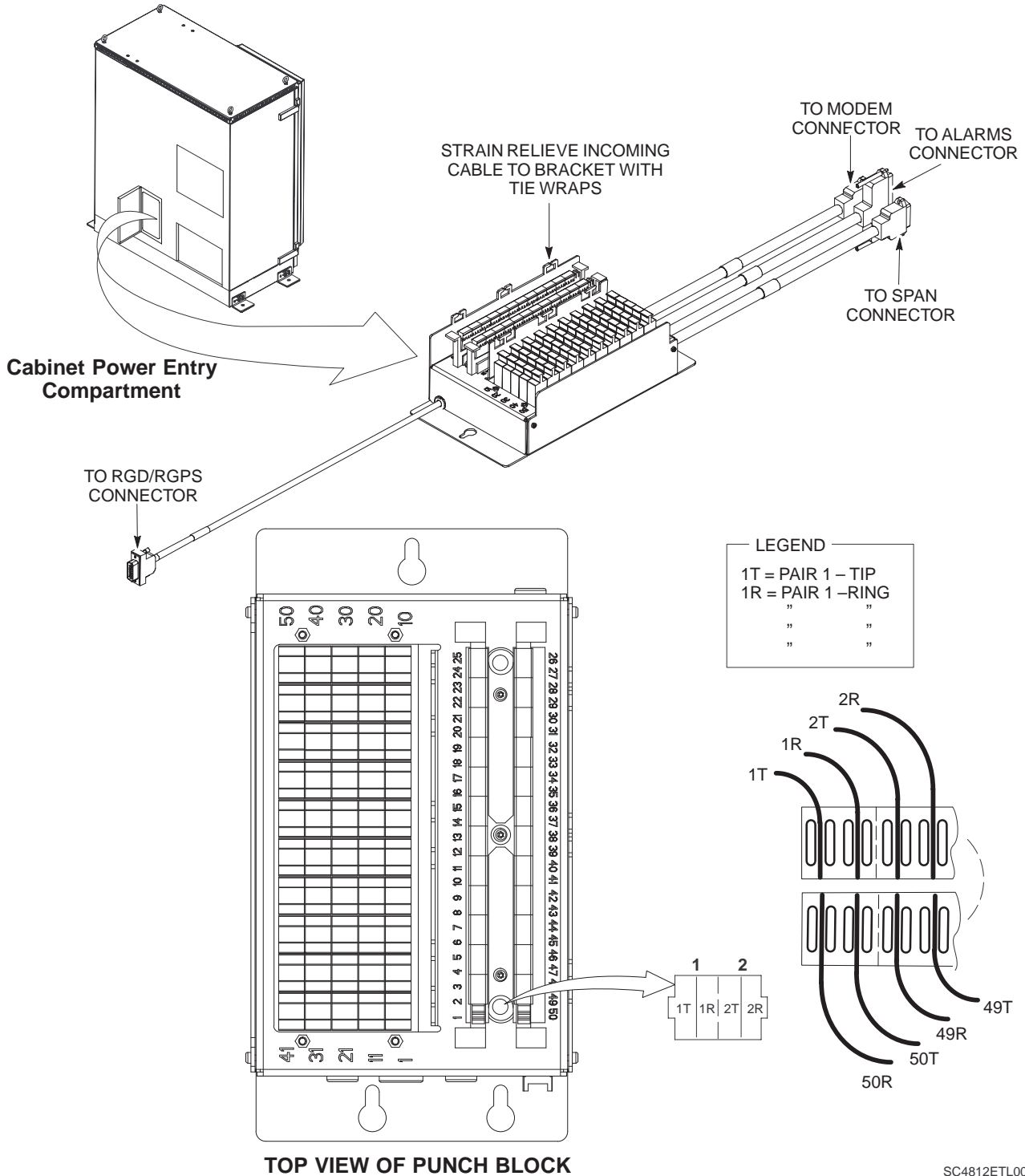



Span Lines – Interface and Isolation – continued

**Table 3-1: Pin-Out for 50 Pin Punch Block**

<i>Site Component</i>	<b>Signal Name</b>	<b>Pin</b>	<b>Color</b>
<b>POWER CABINET</b>	Power Cab Control – NC	1T	Blue
	Power Cab Control – NO	1R	Blk/Blue
	Power Cab Control – Com	2T	Yellow
	Reserved	2R	N/C
	Rectifier Fail	3T	Blk/Yellow
	AC Fail	3R	Green
	Power Cab Exchanger Fail	4T	Blk/Grn
	Power Cab Door Alarm	4R	White
	Power Cab Major Alarm	5T	Blk/Whit
	Battery Over Temp	5R	Red
	Power Cab Minor Alarm	6T	Blk/Red
	Reticifier Over Temp	6R	Brown
	Power Cab Alarm Rtn	7T	Blk/Brn
<b>LFR / HSO</b>	LFR_HSO_GND	7R	
	EXT_1PPS_POS	8T	
	EXT_1PPS_NEG	8R	
	CAL_+	9T	
	CAB_-	9R	
	LORAN_+	10T	
	LORAN_-	10R	
<b>PILOT BEACON</b>	Pilot Beacon Alarm – Minor	11T	
	Pilot Beacon Alarm – Rtn	11R	
	Pilot Beacon Alarm – Major	12T	
	Pilot Beacon Control – NO	12R	
	Pilot Beacon Control – COM	13T	
	Pilot Beacon Control – NC	13R	

... continued on next page

Span Lines – Interface and Isolation – continued

3

**Table 3-1: Pin-Out for 50 Pin Punch Block**

<i>Site Component</i>	<i>Signal Name</i>	<i>Pin</i>	<i>Color</i>
<b>CUSTOMER OUTPUTS / INPUTS</b>	Customer Outputs 1 – NO	14T	
	Customer Outputs 1 – COM	14R	
	Customer Outputs 1 – NC	15T	
	Customer Outputs 2 – NO	15R	
	Customer Outputs 2 – COM	16T	
	Customer Outputs 2 – NC	16R	
	Customer Outputs 3 – NO	17T	
	Customer Outputs 3 – COM	17R	
	Customer Outputs 3 – NC	18T	
	Customer Outputs 4 – NO	18R	
	Customer Outputs 4–COM	19T	
	Customer Outputs 4 – NC	19R	
	Customer Inputs 1	20T	
	Cust_Rtn_A_1	20R	
	Customer Inputs 2	21T	
	Cust_Rtn_A_2	21R	
	Customer Inputs 3	22T	
	Cust_Rtn_A_3	22R	
	Customer Inputs 4	23T	
	Cust_Rtn_A_4	23R	
	Customer Inputs 5	24T	
	Cust_Rtn_A_5	24R	
	Customer Inputs 6	25T	
	Cust_Rtn_A_6	25R	
	Customer Inputs 7	26T	
	Cust_Rtn_A_7	26R	
	Customer Inputs 8	27T	
	Cust_Rtn_A_8	27R	
	Customer Inputs 9	28T	
	Cust_Rtn_A_9	28R	
Customer Inputs 10	29T		
Cust_Rtn_A_10	29R		
<b>SPAN</b>	RVC_TIP_A	30T	
	RVC_RING_A	30R	
	XMIT_TIP_A	31T	
	XMIT_RING_A	31R	
	RVC_TIP_B	32T	
	RVC_RING_B	32R	
	XMIT_TIP_B	33T	
	XMIT_RING_B	33R	
	RVC_TIP_C	34T	
	RVC_RING_C	34R	
	XMIT_TIP_C	35T	
	XMIT_RING_C	35R	
	RVC_TIP_D	36T	
	RVC_RING_D	36R	
	XMIT_TIP_D	37T	
	XMIT_RING_D	37R	
	RVC_TIP_E	38T	
	RVC_RING_E	38R	
	XMIT_TIP_E	39T	
	XMIT_RING_E	39R	
	RVC_TIP_F	40T	
	RVC_RING_F	40R	
	XMIT_TIP_F	41T	
	XMIT_RING_F	41R	

... continued on next page

## Span Lines – Interface and Isolation – continued

<i>Site Component</i>	<b>Signal Name</b>	<b>Pin</b>	<b>Color</b>
<b>RGPS</b>	GPS_POWER_1+	42T	Blue
	GPS_POWER_1-	42R	Bk/Blue
	GPS_POWER_2+	43T	Yellow
	GPS_POWER_2-	43R	Bk/Yellow
	GPS_RX+	44T	White
	GPS_RX-	44R	White
	GPS_TX+	45T	Green
	GPS_TX-	45R	Green
	Signal Ground (TDR+)	46T	Red
	Master Frame (TDR-)	46R	Bk/Red
	GPS_lpps+	47T	Brown
	GPS_lpps-	47R	Bk/Brn
<b>Phone Line</b>	Telco_Modem_T	48T	
	Telco_Modem_R	48R	
<b>Miscellaneous</b>	Chasis Ground	49T	
	Reserved	49R	
	Reserved	50T	
	Reserved	50R	

3

### T1/E1 Span Isolation

Table 3-2 describes the action required for span isolation.

<b>Step</b>	<b>Action</b>
1	Have the OMC/CBSC disable the BTS and place it OOS.
2	To disable the span lines, use Table 3-1 to locate the pins for the span or spans which must be disabled and remove the respective surge protector(s).

# Preparing the LMF

## Overview

Before optimization can be performed, the CDMA LMF must be installed and configured on a computer platform meeting Motorola–specified requirements (see Recommended Test Equipment and Software in Chapter 1).



### IMPORTANT

For the CDMA LMF graphics to display properly, the computer platform must be configured to display *more than 256 colors*. See the operating system software instructions for verifying and configuring the display settings.

Software and files for installing and updating the CDMA LMF are provided on CD ROM disks. The following items must be available:

- CDMA LMF Program on CD ROM
- CDMA LMF Binaries on CD ROM
- Configuration Data File (CDF) for each supported BTS (on floppy disk)
- CBSC File for each supported BTS (on floppy disk)

The following section provides information and instructions for installing and updating CDMA LMF software and files.

## LMF Installation and Update Procedures

### NOTE

First Time Installation Sequence:

- Install Java Runtime Environment (JRE) (**First**)
- Install U/WIN K–shell emulator (**Second**)
- Install LMF software (**Third**)
- Install BTS Binaries (**Fourth**)
- Install/create BTS folders (**Fifth**)

Follow the procedure in Table 3-3 to:

1. Install the CDMA LMF program using the CDMA LMF CD ROM
2. Install binary files using the CDMA LMF CD ROM

**Table 3-3:** CD ROM Installation

Step	Action
1	Insert the CDMA LMF CD ROM disk into your disk drive. <ul style="list-style-type: none"><li>• If the Setup screen appears, follow the instructions displayed on the screen.</li><li>• If the Setup screen is not displayed, proceed to Step 2.</li></ul>
2	Click on the <b>Start</b> button

**Table 3-3: CD ROM Installation**

Step	Action
3	Select <b>Run</b> .
4	Enter <b>d:\autorun</b> in the Open box and click <b>OK</b> . <b>NOTE</b> <i>(If applicable, replace the letter <b>d</b> with the correct CD ROM drive letter.)</i>
5	Follow the directions displayed in the <b>Setup</b> screen.

**Copy CBSC CDF Files to the LMF Computer**

Before logging on to a BTS with the CDMA LMF computer to execute optimization/ATP procedures, the correct **bts-#.cdf** and **cbsc-#.cdf** files must be obtained from the CBSC and put in a **bts-#** folder in the CDMA LMF computer. This requires creating versions of the CBSC CDF files on a DOS-formatted floppy diskette and using the diskette to install the CDF files on the CDMA LMF computer.



**IMPORTANT**

When copying CDF files, comply with the following to prevent BTS login problems with the Windows LMF:

- The numbers used in the **bts-#.cdf** and **cbsc-#.cdf** filenames must correspond to the locally-assigned numbers for each BTS and its controlling CBSC.
- The generic **cbsc-1.cdf** file supplied with the Windows LMF will work with locally numbered BTS CDF files. Using this file *will not provide a valid optimization* unless the generic file is edited to replace default parameters (e.g., channel numbers) with the operational parameters used locally.

The procedure in Table 3-4 lists the steps required to transfer the CDF files from the CBSC to the CDMA LMF computer. For any further information, refer to the *CDMA LMF Operator's Guide* (Motorola part no. 68P64114A21) or the CDMA LMF Help screen.

**Table 3-4: Copying CBSC CDF Files to the LMF Computer**

Step	Action
1	Login to the CBSC workstation.
2	Insert a DOS-formatted floppy diskette in the workstation drive.
3	Type <b>eject -q</b> and press the Enter key.

... continued on next page

**Table 3-4:** Copying CBSC CDF Files to the LMF Computer

Step	Action
4	Type <b>mount</b> and press the Enter key. <b>NOTE</b> <ul style="list-style-type: none"> <li>• Look for the “<i>floppy/no_name</i>” message on the last line displayed.</li> <li>• If the <b>eject</b> command was previously entered, <i>floppy/no_name</i> will be appended with a number. Use the explicit <i>floppy/no_name</i> reference displayed when performing step 7.</li> </ul>
5	Change to the directory, where the files to be copied reside, by typing <b>cd &lt;directoryname&gt;</b> (e.g., <b>cd bts-248</b> ) and pressing the Enter key.
6	Type <b>ls</b> and press the Enter key to display the list of files in the directory.
7	With <i>Solaris versions of Unix</i> , create <i>DOS-formatted versions</i> of the <i>bts-#.cdf</i> and <i>cbsc-#.cdf</i> files on the diskette by entering the following command: <b>unix2dos &lt;source filename&gt; /floppy/no_name/&lt;target filename&gt;</b> (e.g., <b>unix2dos bts-248.cdf /floppy/no_name/bts-248.cdf</b> ). <b>NOTE</b> <ul style="list-style-type: none"> <li>• Other versions of Unix do not support the <b>unix2dos</b> and <b>dos2unix</b> commands. In these cases, use the Unix <b>cp</b> (copy) command. The <i>copied</i> files will be difficult to read with a DOS or Windows text editor because Unix files do not contain line feed characters. Editing <i>copied</i> CDF files on the CDMA LMF computer is, therefore, not recommended.</li> <li>• Using <b>cp</b>, multiple files can be <i>copied</i> in one operation by separating each filename to be copied with a space and ensuring the destination directory (<i>floppy/no_name</i>) is listed at the end of the command string following a space (e.g., <b>cp bts-248.cdf cbsc-6.cdf /floppy/no_name</b>).</li> </ul>
8	Repeat steps 5 through 7 for each <i>bts-#</i> which must be supported by the CDMA LMF computer.
9	When all required files have been copied to the diskette type <b>eject</b> and press the Enter key.
10	Remove the diskette from the CBSC drive.
11	If it is not running, start the Windows operating system on the CDMA LMF computer.
12	Insert the diskette containing the <i>bts-#.cdf</i> and <i>cbsc-#.cdf</i> files into the CDMA LMF computer.
13	Using MS Windows Explorer, create a corresponding <i>bts-#</i> folder in the <i>wlmf\cdma</i> directory for each <i>bts-#.cdf/cbsc-#.cdf</i> file pair copied from the CBSC.
14	Use MS Windows Explorer to transfer the <b>cbsc-#.cdf</b> and <b>bts-#.cdf</b> files from the diskette to the corresponding <b>wlmf\cdma\bts-#</b> folders created in step 13.

3

**Creating a Named HyperTerminal Connection for MMI Communication**

Confirming or changing the configuration data of certain BTS Field Replaceable Units (FRU) requires establishing an MMI communication session between the CDMA LMF computer and the FRU. Using features of the Windows operating system, the connection properties for an MMI session can be saved on the CDMA LMF computer as a named Windows HyperTerminal connection. This eliminates the need for setting up connection parameters each time an MMI session is required to support optimization.

Once the named connection is saved, a shortcut for it can be created on the Windows desktop. Double-clicking the shortcut icon will start the connection without the need to negotiate multiple menu levels.

Follow the procedures in Table 3-5 to establish a named HyperTerminal connection and create a Windows desktop shortcut for it.



**Table 3-5: Create HyperTerminal Connection**

Step	Action
1	From the Windows Start menu, select: <b>Programs &gt; Accessories</b>
2	Select <b>Communications</b> , double click the <b>Hyperterminal</b> folder, and then double click on the <b>Hypertrm.exe</b> icon in the window which opens.  <b>NOTE</b> <ul style="list-style-type: none"> <li>• If a <b>Location Information Window</b> appears, enter the required information, then click on the <b>Close</b> button. (This is required the first time, even if a modem is not to be used.)</li> <li>• If a <b>You need to install a modem.....</b> message appears, click on <b>NO</b>.</li> </ul>
3	When the <b>Connection Description</b> box opens: <ul style="list-style-type: none"> <li>– Type a name for the connection being defined (e.g., MMI Session) in the <b>Name:</b> window,</li> <li>– Highlight any icon preferred for the named connection in the <b>Icon:</b> chooser window, and</li> <li>– Click <b>OK</b>.</li> </ul>
4	<b>NOTE</b> For CDMA LMF computer configurations where COM1 is used by another interface such as test equipment and a physical port is available for COM2, select COM2 in the following step to prevent conflicts.  From the <b>Connect using:</b> pick list in the <b>Connect To</b> box displayed, select <b>Direct to Com 1</b> or <b>Direct to Com 2</b> for the RS–232 connection port, and click <b>OK</b> .

. . . continued on next page

**Table 3-5: Create HyperTerminal Connection**

Step	Action
5	In the <b>Port Settings</b> tab of the <b>COM# Properties</b> window displayed, configure the RS-232 port settings as follows: <ul style="list-style-type: none"> <li>• Bits per second: 9600</li> <li>• Data bits: 8</li> <li>• Parity: None</li> <li>• Stop bits: 1</li> <li>• Flow control: None</li> </ul>
6	Click <b>OK</b> .
7	Save the defined connection by selecting: <b>File &gt; Save</b>
8	Close the HyperTerminal window by selecting: <b>File &gt; Exit</b>
9	Click the <b>Yes</b> button to disconnect when prompted.
10	If the <b>Hyperterminal folder</b> window is still open, proceed to step 12.
11	Select <b>Communications</b> and double click the <b>Hyperterminal</b> folder.
12	Highlight the newly-created connection icon by clicking on it.
13	<i>Right click and drag</i> the highlighted connection icon to the Windows desktop and release the right mouse button.
14	From the popup menu which appears, select <b>Create Shortcut(s) Here</b> .
15	If desired, reposition the shortcut icon for the new connection by dragging it to another location on the Windows desktop.
16	Close the <b>Hyperterminal folder</b> window by selecting: <b>File &gt; Close</b>



## Folder Structure Overview

The CDMA LMF uses a *wlmf* folder that contains all of the essential data for installing and maintaining the BTS. The following list outlines the folder structure for CDMA LMF. Except for the *bts-*nnn** folders, these folders are created as part of the CDMA LMF installation.

**Figure 3-3:** CDMA LMF Folder Structure

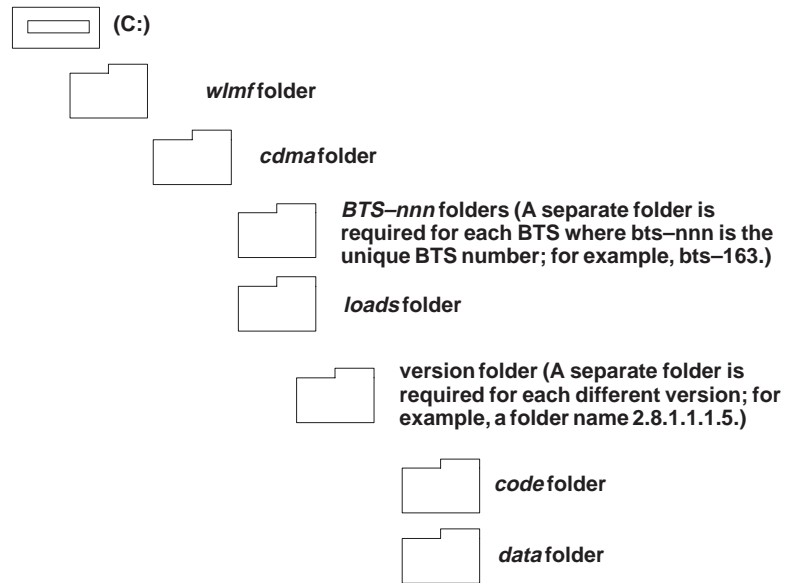

### *wlmf* Folder

The *wlmf* folder contains the CDMA LMF program files.

### *cdma* Folder

The *cdma* folder contains the *bts-*nnn** folders and the *loads* folder. It also contains a default *cbsc-1.cdf* file that can be copied to a *bts-*nnn** folder for use, if one cannot be obtained from the CBSC (Centralized Base Station Controller) when needed.

### *bts-*nnn** Folders

Each *bts-*nnn** folder contains a CAL file, a CDF file and a *cbsc* file for the BTS. Other files required by CDMA LMF may also be located in the *bts-*nnn** folder. A *bts-*nnn** folder must be created for each BTS that is to be logged in to. The *bts-*nnn** folder must be correctly named (for example: *bts-273*) and must be placed in the *cdma* folder. Figure 3-4 shows an example of the file naming syntax for a BTS folder.

**Figure 3-4:** BTS Folder Name Syntax Example

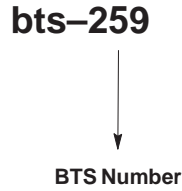

**bts-*nnn*.cal** File

The CAL (Calibration) file contains the bay level offset data (BLO) that is used for BLO downloads to the BBX devices. The CAL file is automatically created and updated by the CDMA LMF when TX calibration is performed. Figure 3-5 details the file name syntax for the CAL file.

**Figure 3-5:** CAL File Name Syntax Example

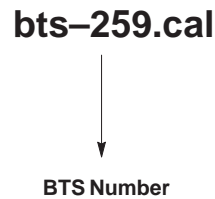

**bts-*nnn*.cdf** File

The CDF file contains data that defines the BTS and data that is used to download data to the devices. A CDF file must be placed in the applicable BTS folder before the CDMA LMF can be used to log into that BTS. CDF files are normally obtained from the CBSC using a floppy disk. A file transfer protocol (ftp) method can be used if the CDMA LMF computer has that capability. Figure 3-6 details the file name syntax for the CDF file.

**Figure 3-6:** CDF Name Syntax Example

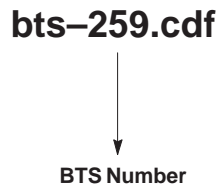

### ***cbsc* File**

The *cbsc-#.cdf* (Centralized Base Station Controller) file contains data for the BTS. If one is not obtained from the CBSC, a copy of the default *cbsc-1.cdf* file located in the *cdma* folder can be used.



#### **IMPORTANT**

Using the *generic cbsc-1.cdf* file will not provide a valid optimization unless the generic file is edited to replace default parameters with local operational parameters (e.g., CDMA channel numbers must be changed from the default “384” to those used locally by the BTS).

### ***loads* Folder**

The *loads* folder contains the version folder(s). It does not contain any files.

### ***version* Folder**

The *version* folder(s) contains the *code* and *data* folders. It does not contain any files. The name of version folders is the software version number of the code files that are included in its code folder. Version folders are created as part of the CDMA LMF installation and CDMA LMF updates. Each time the CDMA LMF is updated, another version folder will be created with the number of the software version for the code files being installed.

### ***code* Folder**

The code folder contains the binary files used to load code into the devices. A unique binary code file is required for each device type in the BTS to be supported with the CDMA LMF. Current version code files for each supported device created in this folder from the CDMA LMF CD ROM as part of the CDMA LMF installation/update process. Figure 3-7 shows an example of the file naming syntax for a code load file.

Figure 3-7: Code Load File Name Syntax Example

**bbx\_ram.bin.0600**

Device Type

Hardware bin number

If this number matches the bin number of the device, the code file will automatically be used for the download\*

\* The device bin number can be determined by using the Status function after logging into a BTS. If the device does not have a bin number, one of the following default numbers must be used.

GLI=0100  
LCI=0300  
MCC=0C00  
BBX=0600  
BDC=0700  
CSM=0800  
TSU=0900  
LPAC=0B00  
MAWI=0D00

If a code file with the correct version and bin numbers is not found, a file selection window will appear.

### data Folder

The data folder contains a DDS (Device Definition Structure) data file for each supported device type. The DDS files are used to specify the CDF file data that is used to download data to a device. Current version DDS files for each supported device type are created in this folder from the CDMA LMF CD ROM as part of the CDMA LMF installation or update process. Figure 3-8 shows an example of the file naming syntax for a code load file.

Figure 3-8: DDS File Name Syntax Example

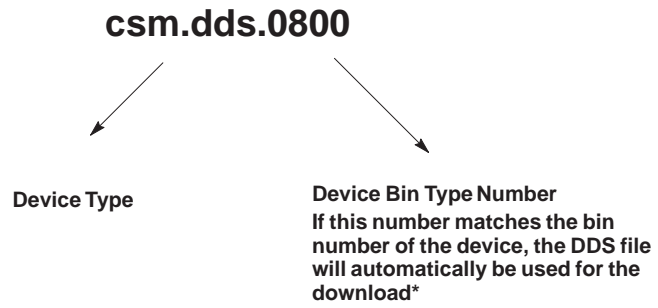

\* The device bin number can be determined by using the Status function after logging into a BTS. If the device does not have a bin number, one of the following default numbers must be used.

- GLI=0100
- LCI=0300
- MCC=0C00
- BBX=0600
- BDC=0700
- CSM=0800
- TSU=0900
- LPAC=0B00

# LMF to BTS Connection

## LMF to BTS Connection

The CDMA LMF computer is connected to the LAN A or B connector located behind the frame lower air intake grill. Figure 3-9 below shows the general location of these connectors.

**Table 3-6: Connect the LMF to the BTS**

Step	Action
1	To gain access to the LAN connectors, open the LAN cable and utility shelf access panel, then <i>pull apart the hook-and-loop tape covering the BNC "T" connector</i> . If desired, slide out the utility shelf for the LMF computer.
2	Connect the CDMA LMF computer to the LAN A (left-hand) BNC connector via PCMCIA Ethernet Adapter.  <b>NOTE</b> Xircom Model PE3-10B2 or equivalent can also be used to interface the CDMA LMF Ethernet connection to the BTS frame connected to the PC parallel port, powered by an external AC/DC transformer. In this case, <i>the BNC cable must not exceed three feet in length</i> .  <b>* IMPORTANT</b> The LAN shield is isolated from chassis ground. The LAN shield (exposed portion of BNC connector) <b>must not touch the chassis</b> during optimization.

**Figure 3-9: LMF Connection Detail**

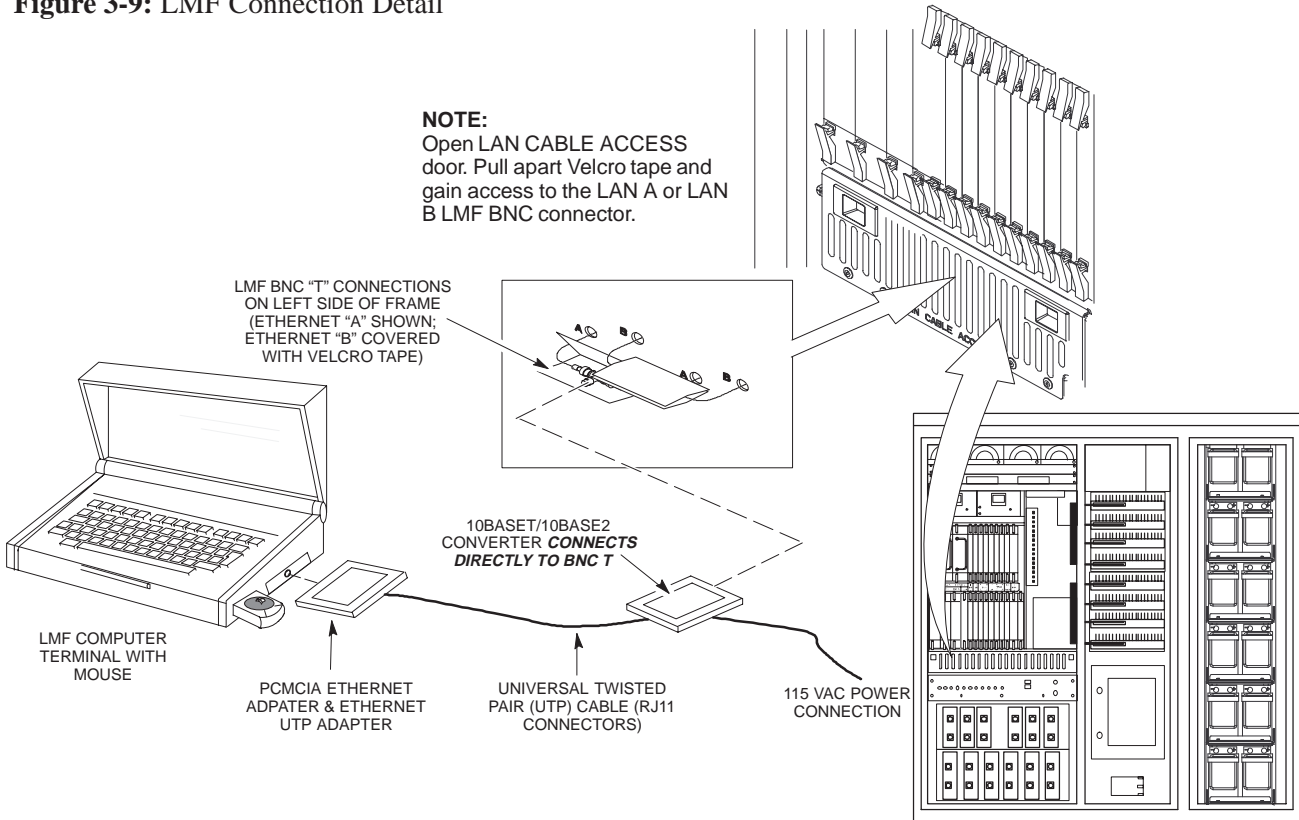

SC4812ETL0012-1

# Using CDMA LMF

## Basic CDMA LMF Operation

The CDMA LMF allows the user to work in the two following operating environments which are accessed using the specified desktop icons:

- Graphical User Interface (GUI) using the WinLMF icon
- Command Line Interface (CLI) using the WinLMF CLI icon

The GUI is the *primary* optimization and acceptance testing operating environment. The CLI environment provides additional capability to the user to perform manually controlled acceptance tests and audit the results of optimization and calibration actions.

Basic operation of the CDMA LMF in either environment includes performing the following:

- Selecting and Deselecting BTS devices
- Enabling devices
- Disabling devices
- Resetting devices
- Obtaining device status

The following additional basic operation can be performed in a GUI environment:

- Sorting a status report window

For detailed information on performing these and other CDMA LMF operations, refer to the *CDMA LMF Operator's Guide – 68P64114A21*.



### IMPORTANT

*Unless otherwise noted, LMF procedures in this manual are performed using the GUI environment.*

## Logging Into a BTS



### WARNING

Be sure that the correct **bts-#.cdf** and **cbsc-#.cdf** file is used for the BTS. These should be the CDF files that are provided for the BTS by the CBSC. Failure to use the correct CDF files can result in invalid optimization.

**Failure to use the correct CDF files to log into a live (traffic-carrying) site can shut down the site.**

Logging into a BTS establishes a communications link between the BTS and the CDMA LMF. You may be logged into one or more BTSs at a time, but only one CDMA LMF may be logged into each BTS.

Before attempting to start the CDMA LMF computer and the CDMA LMF software, confirm the CDMA LMF computer is properly connected

to the BTS (see Table 3-6). Follow the procedures in Table 3-7 to log into a BTS.

**Prerequisites**

*Before attempting to login to a BTS*, ensure the following have been completed:

- The CDMA LMF is correctly installed and prepared.
- A *bts-**nnn*** folder with the correct CDF and CBSC files exists.
- The CDMA LMF computer was connected to the BTS before starting the Windows operating system and the CDMA LMF software. If necessary, restart the computer after connecting it to the BTS in accordance with Table 3-6 and NO TAG.

**BTS Login from the GUI Environment**

Follow the procedures in Table 3-7 to log into a BTS when using the GUI environment.

**Table 3-7: BTS GUI Login Procedure**

✓	Step	Action
	1	Start the CDMA LMF GUI environment by double-clicking on the WinLMF desktop icon (if the LMF is not running).  <b>NOTE</b> If a warning similar to the following is displayed, select <b>No</b> , shut down other LMF sessions which may be running, and start the CDMA LMF GUI environment again:  <pre>The CLI handler is already running. This may cause conflicts with the LMF. Are you sure you want to start the application?                  Yes                No</pre>
	2	Click on <b>Login</b> tab (if not displayed).
	3	Double click on <b>CDMA</b> (in the <b>Available Base Stations</b> pick list).
	4	Click on the desired BTS number.
	5	Click on the <b>Network Login</b> tab (if not already in the forefront).
	6	Enter correct IP address (normally <b>128.0.0.2</b> ) for a field BTS, if not correctly displayed in the <b>IP Address</b> box.
	7	Type in the correct IP Port number (normally <b>9216</b> ) if not correctly displayed in the <b>IP Port</b> box.
	8	Change the <b>Multi-Channel Preselector</b> from the <b>Multi-Channel Preselector</b> pick list (normally <b>MPC</b> ) to a device corresponding to your BTS configuration, if required.
	9	Click on the <b>Use a Tower Top Amplifier</b> , if applicable.

... continued on next page



**Table 3-7: BTS GUI Login Procedure**

✓	Step	Action
	10	<p>Click on <b>Login</b>. (A BTS tab with the BTS is displayed.)</p> <p><b>NOTE</b></p> <ul style="list-style-type: none"><li>• If you attempt to log into a BTS that is already logged on, all devices will be gray.</li><li>• There may be instances where the BTS initiates a log out due to a system error (i.e., a device failure).</li><li>• If the MGLI is OOS-ROM (blue), it must be downloaded with RAM code before other devices can be seen.</li><li>• If the MGLI is OOS-RAM (yellow), it must be enabled before other installed devices can be seen.</li></ul>

**BTS Login from the CLI Environment**

Follow the procedures in Table 3-8 to log into a BTS when using the CLI environment.



**IMPORTANT**

If the CLI and GUI environments are to be used at the same time, the *GUI must be started first and BTS login must be performed from the GUI*. Refer to Table 3-7 to start the GUI environment and log into a BTS.

**Table 3-8: BTS CLI Login Procedure**

✓	Step	Action
	1	Double-click the WinLMF CLI desktop icon (if the LMF CLI environment is not already running).
	2	<p><b>NOTE</b> If a BTS was logged into under a GUI session before the CLI environment was started, the CLI session will be logged into the same BTS, and step 2 is not required.</p> <p>At the /wlmf prompt, enter the following command:</p> <pre>login bts-&lt;bts#&gt; &lt;host&gt; &lt;port&gt;</pre> <p>where:</p> <p>host = MGLI card IP address (defaults to address last logged into for this BTS or 128.0.0.2 if this is first login to this BTS)</p> <p>port = IP port of the BTS (defaults to port last logged into for this BTS or 9216 if this is first login to this BTS)</p> <p>A response similar to the following will be displayed:</p> <pre>LMF&gt; 13:08:18.882 Command Received and Accepted           COMMAND=login bts-33  13:08:18.882 Command In Progress  13:08:21.275 Command Successfully Completed           REASON_CODE="No Reason"</pre>

**Logging Out**

Logging out of a BTS is accomplished differently for the GUI and CLI operating environments.



**IMPORTANT**

The GUI and CLI environments use the same connection to a BTS. If a BTS is logged into in both the GUI and CLI environments at the same time, logging out of the BTS in either environment will log out of it for both. When the logout is performed in the CLI window, there is no GUI indication that logout has occurred.

**Logging Out of a BTS from the GUI Environment**

Follow the procedure in Table 3-9 to logout of a BTS when using the GUI environment.

**Table 3-9: BTS GUI Logout Procedure**

✓	Step	Action
	1	Click on <b>Select</b> on the BTS tab menu bar.
	2	Click the <b>Logout</b> item in the pulldown menu (a <b>Confirm Logout</b> pop-up message will appear).
	3	Click on <b>Yes</b> (or press the <b>Enter</b> key) to confirm logout. The <b>Login</b> tab will appear.  <b>NOTE</b> If a logout was previously performed on the BTS from a CLI window running at the same time as the GUI, a <b>Logout Error</b> popup message will appear stating the system could not log out of the BTS. When this occurs, the GUI must be exited and restarted before it can be used for further operations.
	4	If a <b>Logout Error</b> popup message appears stating that the system could not log out of the Base Station because the given BTS is not logged in, click <b>OK</b> and proceed to step 5.
	5	Select <b>File &gt; Exit</b> in the window menu bar, click <b>Yes</b> in the <b>Confirm Logout</b> popup, and click <b>Yes</b> in the <b>Logout Error</b> popup which appears again.
	6	If further work is to be done in the GUI, restart it.  <b>NOTE</b> <ul style="list-style-type: none"> <li>• The Select menu on the BTS tab will only log you out of the displayed BTS.</li> <li>• You can also log out of all BTS sessions and exit CDMA LMF by clicking on the <b>File</b> selection in the menu bar and selecting <b>Exit</b> from the <b>File</b> menu list. A <b>Confirm Logout</b> pop-up message will appear.</li> </ul>

**Logging Out of a BTS from the CLI Environment**

Follow the procedure in Table 3-10 to logout of a BTS when using the CLI environment.

**Table 3-10: BTS CLI Logout Procedure**

✓	Step	Action
	1	<p><b>* IMPORTANT</b></p> <p>If the BTS is also logged into from a GUI running at the same time and further work must be done with it in the GUI, proceed to step 2.</p> <p>Logout of a BTS by entering the following command:</p> <p><b>logout bts-&lt;bts#&gt;</b></p> <p>A response similar to the following will be displayed:</p> <pre>LMF&gt; 13:24:51.028 Command Received and Accepted           COMMAND=logout bts-33  13:24:51.028 Command In Progress  13:24:52.04  Command Successfully Completed           REASON_CODE="No Reason"</pre>
	2	<p>If desired, close the CLI interface by entering the following command:</p> <p><b>exit</b></p> <p>A response similar to the following will be displayed before the window closes:</p> <pre>Killing background processes....</pre>

**Establishing an MMI Communication Session**

For those procedures which require MMI communication between the CDMA LMF and BTS FRUs, follow the procedures in Table 3-11 to initiate the communication session.

Figure 3-10 illustrates common equipment connections for the CDMA LMF computer. For specific connection locations on FRUs, refer to the illustration accompanying the procedures which require the MMI communication session.

**Table 3-11: Establishing MMI Communication**

Step	Action
1	Connect the CDMA LMF computer to the equipment as detailed in the applicable procedure which requires the MMI communication session.
2	Start the named HyperTerminal connection for MMI sessions by double clicking on its Windows desktop shortcut.

... continued on next page



Table 3-11: Establishing MMI Communication	
Step	Action
	<p><b>NOTE</b></p> <p>If a Windows desktop shortcut was not created for the MMI connection, access the connection from the Windows Start menu by selecting:</p> <p><b>Programs &gt; Accessories &gt; Hyperterminal &gt; HyperTerminal &gt; &lt;Named HyperTerminal Connection (e.g., MMI Session)&gt;</b></p>
3	Once the connection window opens, establish MMI communication with the BTS FRU by pressing the CDMA LMF computer Enter key until the prompt identified in the applicable procedure is obtained.

Figure 3-10: CDMA LMF Computer Common MMI Connections

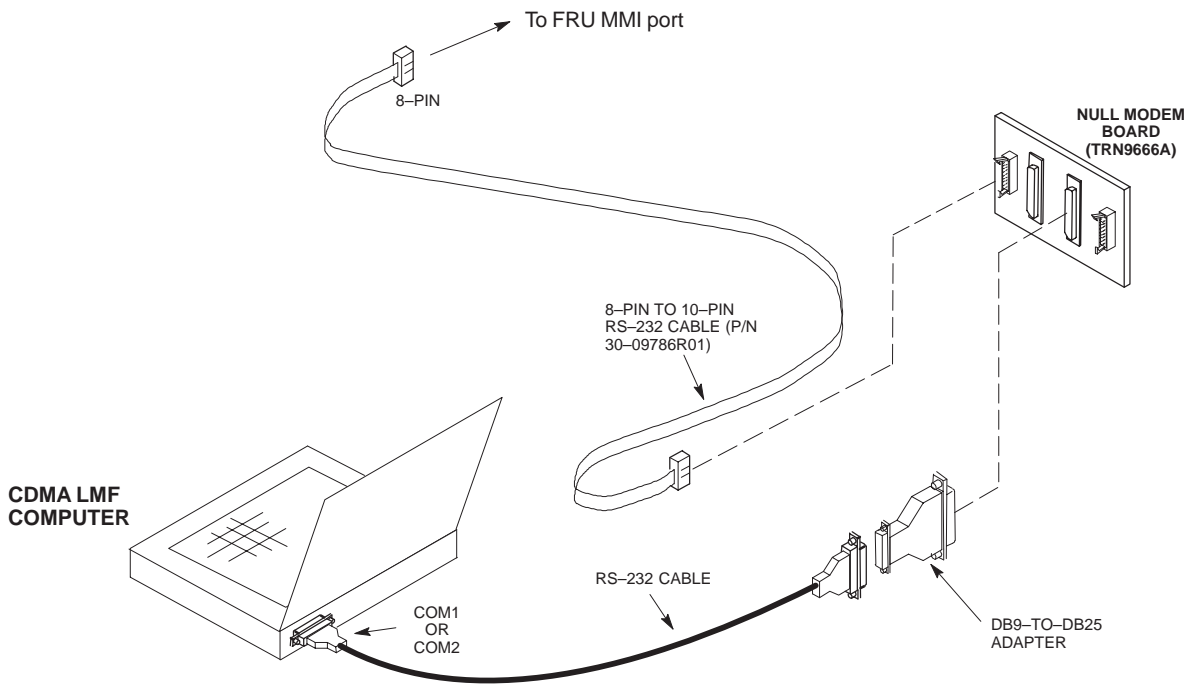

Online Help

Task oriented online help is available in CDMA LMF by clicking on **Help** in the menu bar.

# Pinging the Processors

## Pinging the BTS

For proper operation, the integrity of the Ethernet LAN A and B links must be verified. NO TAG represents a typical BTS Ethernet configuration. The drawing depicts one (of two identical) links, A and B.

Ping is a program that sends request packets to the LAN network modules to get a response from the specified "target" module.

Follow the steps in Table 3-12 to ping each processor (on both LAN A and LAN B) and verify LAN redundancy is working properly.



### CAUTION

Always wear a conductive, high impedance wrist strap while handling any circuit card/module to prevent damage by ESD.

Figure 3-11: BTS Ethernet LAN Interconnect Diagram

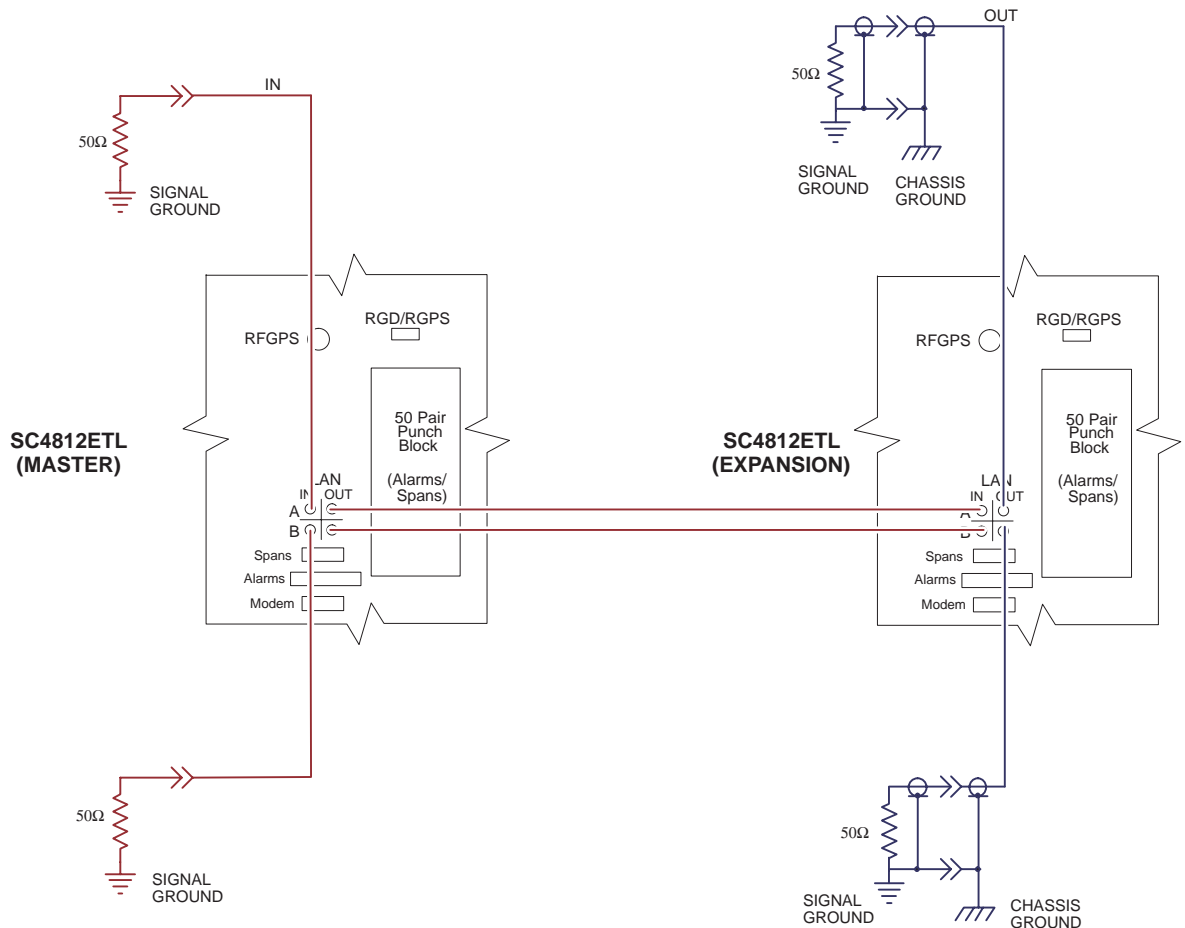

SC4812ETL0013-1



**IMPORTANT**

The Ethernet LAN A and B cables must be installed on each frame/enclosure before performing this test. All other processor board LAN connections are made via the backplanes.

**Table 3-12: Pinging the Processors**

Step	Action
1	From the Windows desktop, click the <b>Start</b> button and select <b>Run</b> .
2	In the <b>Open</b> box, type <b>ping</b> and the <b>GLI2 IP address</b> (for example, <b>ping 128.0.0.2</b> ).  <b>NOTE</b> 128.0.0.2 is the default IP address for the GLI2 in field BTS units.
3	Click on the <b>OK</b> button.
4	If the targeted module responds, text similar to the following is displayed: Reply from 128 128.0.0.2: bytes=32 time=3ms TTL=255  If there is no response the following is displayed: Request timed out  If the GLI2 fails to respond, it should be reset and re-pinged. If it still fails to respond, typical problems are shorted BNC to inter-frame cabling, open cables, crossed A and B link cables, or the GLI2 itself.

### Overview

Before a BTS can operate, each equipped device must contain device initialization (ROM) code. ROM code is loaded in all devices during manufacture or factory repair. Device application (RAM) code and data must be downloaded to each equipped device by the user before the BTS can be made fully functional for the site where it is installed.

#### ROM Code

Downloading ROM code to BTS devices from the CDMA LMF is *NOT routine maintenance or a normal part of the optimization process*. It is only done in unusual situations where the resident ROM code in the device does not match the release level of the site operating software *AND* the CBSC can not communicate with the BTS to perform the download. An example would be a BTS loaded with Release 9.2 software where a GLI loaded with Release 2.8.1 ROM code must be installed to replace a malfunctioning MGLI.

Before ROM code can be downloaded from the CDMA LMF, the correct ROM code file for each device to be loaded must exist on the LMF computer. ROM code *must be manually selected* for download.

ROM code can be downloaded to a device that is in any state. After the download is started, the device being downloaded will change to OOS-ROM (blue). The device will remain OOS-ROM (blue) when the download is completed. The same Revision-level RAM code must then be downloaded to the device. For example, if Release 2.9.2.1.1 ROM code is downloaded, Release 2.9.2.1.1 RAM code must be downloaded.

Procedures to load ROM code are located in Appendix G.

#### RAM Code

Before RAM code can be downloaded from the CDMA LMF, the correct RAM code file for each device must exist on the LMF computer. RAM code can be automatically or manually selected depending on the **Device** menu item chosen and where the RAM code file for the device is stored in the CDMA LMF file structure. The RAM code file will be selected automatically if the file is in the `\lmf\cdma\loads\n.n.n.n\code` folder (where *n.n.n.n* is the version number of the download code that matches the “NextLoad” parameter of the CDF file). The RAM code file in the code folder must have the correct hardware bin number.

RAM code can be downloaded to a device that is in any state. After the download is started, the device being loaded will change to OOS-ROM (blue). When the download is completed successfully, the device will change to OOS-RAM (yellow). When code is downloaded to an MGLI or GLI, the CDMA LMF automatically also downloads data and then enables the MGLI. When enabled, the MGLI will change to INS (green).

For non-GLI devices, data must be downloaded after RAM code is downloaded. To download data, the device state must be OOS-RAM (yellow).



The devices to be loaded with RAM code and data are:

- Master Group Line Interface (MGLI2)
- Redundant GLI (GLI2)
- Clock Synchronization Module (CSM) (*Only if new revision code must be loaded*)
- Multi Channel CDMA (MCC24) card
- Broadband Transceiver (BBX2)
- RFDS Test Subscriber Interface Card (TSIC), if equipped



### IMPORTANT

The MGLI *must* be successfully downloaded with RAM code and data, and in INS (green) status *before* downloading any other device. The RAM code download process for an MGLI automatically downloads data and then enables the MGLI.

RAM code downloading requires a few minutes. After the download starts, the non-GLI device being loaded changes to OOS-ROM (blue). If the download is completed successfully, the non-GLI device changes to OOS-RAM (yellow).

**Download RAM Code and Data to MGLI and GLI**

Follow the steps outlined in Table 3-13 to download the RAM code and data to the MGLI and other installed GLI devices.



**CAUTION**

Release 2.9.x RAM code must NOT be downloaded to a device loaded with Release 2.8.x ROM code, and Release 2.8.x RAM code must NOT be downloaded to a device loaded with Release 2.9.x ROM code.

All devices in a BTS must have the same Release-level ROM and RAM code before the optimization and ATP procedures can be performed.

If a newly-installed Release 8-equipped BTS is to be upgraded to Release 2.9.x, the optimization and Acceptance Test Procedures (ATP) should be accomplished with the Release 2.8.x code and software. Following the optimization, the site code and software should be upgraded to Release 2.9.x by the CBSC. It is not necessary to perform the optimization and ATPs again after the upgrade.

If a replacement device with Release 2.8.x ROM code must be used in a Release 2.9.x-equipped BTS, the device ROM code can be changed using the CDMA LMF before the performing the BTS optimization and ATPs. *A device loaded with Release 2.9.x ROM code can not be converted back to Release 2.8.x ROM code in the field without Motorola assistance.*

**Prerequisites**

- Prior to performing these procedures, ensure a code file exists for each of the devices to be loaded.
- The CDMA LMF computer is connected to the BTS (refer to Table 3-6), and is logged in using the GUI environment (refer to Table 3-7).

**Table 3-13:** Download and Enable MGLI and GLI Devices

Step	Action
1	From the <b>Util</b> pull down menu, select <b>Tools</b> , then <b>Update NextLoad</b> .
2	Select the correct code version and click <b>Save</b> .
3	Download code to the MGLI by clicking on the device.
4	From the <b>Device</b> pull down menu, select <b>Download Code</b> . A status report is displayed confirming change in the device(s) status. Click <b>OK</b> to close the status window. <i>(The MGLI will automatically be downloaded with data and enabled.)</i>

... continued on next page

**Table 3-13:** Download and Enable MGLI and GLI Devices

Step	Action
5	Once the MGLI is enabled, load and enable additional installed GLIs by clicking on the devices and repeating step 4.
6	Click <b>OK</b> to close the status window for the additional GLI devices.

**Download RAM Code and Data to Non-GLI Devices**

Downloads to non-GLI devices can be performed individually for each device or all installed devices can be downloaded with one action. RAM code and data are downloaded to non-GLI devices in separate steps.



**IMPORTANT**

CSM devices are RAM code-loaded at the factory. RAM code is downloaded to CSMs *only if a newer software version needs to be loaded.*

**NOTE**

When downloading to multiple devices, the download may fail for some of the devices (a time-out occurs). These devices can be loaded individually after completing the multiple download.

Follow the steps in Table 3-14 to download RAM code and data to non-GLI devices.

**Table 3-14:** Download RAM Code and Data to Non-GLI Devices

Step	Action
1	Select the target CSM, BDC, MCC, BBX, and ELPA Gateway device(s).
2	From the <b>Device</b> pull down menu, select <b>Download Code</b> . A status report is displayed that shows the results of the download for each selected device.
3	Click <b>OK</b> to close the status report window when downloading is completed. <b>NOTE</b> After a BBX, CSM, MCC, or ELPA Gateway device is successfully loaded with RAM code and has changed to the OOS-RAM state (yellow), the status LED should be rapidly flashing GREEN.
4	To download data, select the target CSM, BDC, MCC, BBX, and ELPA Gateway device(s).
5	From the <b>Device</b> pull down menu, select <b>Download Data</b> . A status report is displayed that shows the results of the download for each selected device.
6	Click <b>OK</b> to close the status report window when downloading is completed.

Select CSM Clock Source

A CSM can have three different clock sources. The Select CSM Source function can be used to select the clock source for each of the three inputs. This function is only used if the clock source for a CSM needs to be changed. The Clock Source function provides the following clock source options.

- Local GPS
- Remote GPS
- HSO (only for source 2 & 3)
- LFR (only for source 2 & 3)
- 10 MHz (only for source 2 & 3)
- NONE (only for source 2 & 3)

**Prerequisites**

MGLI=INS\_ACT (green), CSM= OOS\_RAM (yellow) or INS\_ACT (green)

**Table 3-15:** Select CSM Clock Source

Step	Action
1	Select the applicable CSM(s).
2	Click on the <b>Device</b> menu.
3	Click on the <b>Clock Source</b> menu item.
4	Click on the <b>Select</b> menu item. A clock source selection window is displayed.
5	Select the applicable clock source in the <b>Clock Reference Source</b> pick lists. Uncheck the related check box if you do not want the displayed pick list item to be used.
6	Click on the <b>OK</b> button. A status report window is displayed showing the results of the selection action.
7	Click on the <b>OK</b> button to close the status report window.

**Enable CSMs**

Each BTS CSM system features two CSM boards per site. In a typical operation, the primary CSM locks its Digital Phase Locked Loop (DPLL) circuits to GPS signals. These signals are generated by either an on-board GPS module (RF-GPS) or a remote GPS receiver (R-GPS). The GPS receiver interfaced to CSM 1 is used as the primary timing reference and synchronizes the entire cellular system. CSM 2 provides clock synchronization redundancy, but does not have a GPS receiver.

The BTS may be equipped with a LORAN-C Low Frequency Receiver (LFR) High Stability Oscillator (HSO), or external 10 MHz Rubidium source which the CSM can use as a secondary timing reference. In all cases, the CSM monitors and determines what reference to use at a given time.





**IMPORTANT**

For RF-GPS, verify the CSM configured with the GPS receiver “daughter board” is installed in the frame’s CSM 1 slot before continuing.

Follow the steps outlined in Table 3-16 to enable the CSMs installed in the SCCP shelves.

**Table 3-16:** Enable CSMs

Step	Action
1	<p>Click on the target CSM. From the <b>Device</b> pull down, select <b>Enable</b>.</p> <p><b>NOTE</b> If equipped with two CSMs, enable CSM-2 first A status report is displayed confirming change in the device(s) status. Click <b>OK</b> to close the status report window.</p> <p><b>NOTE</b> FAIL may be shown in the status table for enable action. If Waiting For Phase Lock is shown in the Description field, the CSM changes to the Enabled state after phase lock is achieved. CSM 1 houses the GPS receiver. The enable sequence can take up to <i>one hour</i> (see below).</p> <p><b>* IMPORTANT</b> The GPS satellite system satellites are not in a geosynchronous orbit and are maintained and operated by the United States Department of Defense (D.O.D.). The D.O.D. periodically alters satellite orbits; therefore, satellite trajectories are subject to change. A GPS receiver that is INS contains an “almanac” that is updated periodically to take these changes into account. If a GPS receiver has not been updated for a number of weeks, it may take up to an hour for the GPS receiver “almanac” to be updated. Once updated, the GPS receiver must track at least four satellites and obtain (hold) a 3-D position fix for a minimum of 45 seconds before the CSM will come in service. (In some cases, the GPS receiver needs to track only one satellite, depending on accuracy mode set during the data load).</p>
2	<p><b>NOTE</b> If equipped with two CSMs, CSM-1 should be bright green (INS-ACT) and CSM-2 should be dark green(INS-STB) If more than an hour has passed, refer to CSM Verification, see Figure 3-12 and Table 3-19 to determine the cause.</p> <p><b>NOTE</b> After the CSMs have been successfully enabled, observe the PWR/ALM LEDs are steady green (alternating green/red indicates the card is in an alarm state).</p>

**Enable MCCs**

This procedure configures the MCC and sets the “tx fine adjust” parameter. The “tx fine adjust” parameter is not a transmit gain setting,

but a timing adjustment that compensates for the processing delay in the BTS (approximately 3  $\mu$ S).

Follow the steps outlined in Table 3-17 to enable the MCCs installed in the SCCP shelves.



**IMPORTANT**

The MGLI and CSM must be downloaded and enabled, prior to downloading and enabling the MCC.

**Table 3-17:** Enable MCCs

Step	Action
1	Click on the target MCC(s) or from the <b>Select</b> pull down menu choose <b>All MCCs</b> .
2	From the <b>Device</b> menu, select <b>Enable</b> A status report is displayed confirming change in the device(s) status.
3	Click <b>OK</b> to close the status report window.

---

## CSM System Time – GPS & LFR/HSO Verification

### Clock Synchronization Manager (CSM) System Time

The primary function of the Clock Synchronization Manager (CSM) boards (slots 1 and 2) is to maintain CDMA system time. The CSM in slot 1 is the primary timing source while slot 2 provides redundancy. The CSM2 card (CSM second generation) is required when using the remote GPS receiver (R-GPS). R-GPS uses a GPS receiver in the antenna head that has a digital output to the CSM2 card. CSM2 can have a daughter card as a local GPS receiver to support an RF-GPS signal.

The CSM2 switches between the primary and redundant units (slots 1 and 2) upon failure or command. CDMA Clock Distribution Cards (CCDs) buffer and distribute even-second reference and 19.6608 MHz clocks. CCD 1 is married to CSM 1 and CCD 2 is married to CSM 2. A failure on CSM 1 or CCD 1 cause the system to switch to redundant CSM 2 and CCD 2.

Each CSM2 board features an ovenized, crystal oscillator that provides 19.6608 MHz clock, even second pulse, and 3 MHz referenced to the selected synchronization source (see Table 3-19):

- GPS: local/RF-GPS or remote/R-GPS
- LORAN-C Frequency Receiver (LFR) or High Stability Oscillator (HSO)
- External reference oscillator sources

Fault management has the capability of switching between the GPS synchronization source and the LFR/HSO backup source in the event of a GPS receiver failure on CSM 1. During normal operation, the CSM 1 board selects GPS as the primary source (see Table 3-19). The source selection can also be overridden via the LMF or by the system software.

Synchronization between the primary and redundant CSM CCD pairs, as well as the LFR or HSO back-up to GPS synchronization, increases reliability.

### Low Frequency Receiver/ High Stability Oscillator

The CSM handles the overall configuration and status monitoring functions of the LFR/HSO. In the event of GPS failure, the LFR/HSO is capable of maintaining synchronization initially established by the GPS reference signal.

The LFR requires an active external antenna to receive LORAN RF signals. Timing pulses are derived from this signal, which is synchronized to Universal Time Coordinates (UTC) and GPS time. The LFR can maintain system time indefinitely after initial GPS lock.

The HSO is a high stability 10 MHz oscillator with the necessary interface to the CSMs. The HSO is typically installed in those geographical areas not covered by the LORAN-C system. Since the HSO is a free-standing oscillator, system time can only be maintained for 24 hours after 24 hours of GPS lock.

### Upgrades and Expansions: LFR2/HSO2/HSOX

LFR2/HSO2 (second generation cards) both export a timing signal to the expansion or logical BTS frames. The associated expansion or logical frames require an HSO-expansion (HSOX) whether the starter frame has an LFR2 or an HSO2. The HSOX accepts input from the starter frame and interfaces with the CSM cards in the expansion frame. LFR and LFR2 use the same source code in source selection (see Table 3-19). HSO, HSO2, and HSOX use the same source code in source selection (see Table 3-19).

#### NOTE

Allow the **base site and test equipment to warm up for 60 minutes** after any interruption in oscillator power. CSM board warm-up allows the oscillator oven temperature and oscillator frequency to stabilize prior to test. Test equipment warm-up allows the Rubidium standard timebase to stabilize in frequency before any measurements are made.



**CSM Frequency Verification**

The objective of this procedure is the initial verification of the Clock Synchronization Module (CSM) boards before performing the rf path verification tests. Parts of this procedure will be repeated for final verification *after* the overall optimization has been completed.

**Test Equipment Setup  
(GPS & LFR/HSO Verification)**

Follow the steps outlined in Table 3-18 to set up test equipment.

**Table 3-18:** Test Equipment Setup (GPS & LFR/HSO Verification)

Step	Action
1a	For <b>local GPS</b> (RF-GPS): Verify a CSM board with a GPS receiver is installed in primary CSM slot 1 and that CSM-1 is INS.  <b>NOTE</b> This is verified by checking the board ejectors for kit number <b>SGLN1145</b> on the board in slot 1.
1b	For <b>Remote GPS</b> (RGPS): Verify a CSM2 board is installed in primary slot 1 and that CSM-1 is INS.  <b>NOTE</b> This is verified by checking the board ejectors for kit number <b>SGLN4132CC</b> (or subsequent).
2	Remove CSM-2 (if installed) and connect a serial cable from the LMF COM 1 port (via null modem board) to the MMI port on CSM-1 (see Figure 3-12).
3	Reinstall CSM-2.
4	Start an MMI communication session with CSM-1 by using the Windows desktop shortcut icon (see NO TAG)  <b>NOTE</b> The LMF program must be running when a Hyperterminal session is started.
5	When the terminal screen appears press the <b>Enter</b> key until the <b>CSM&gt;</b> prompt appears.



**CAUTION**

- Connect GPS antenna to the (GPS) RF connector **ONLY**. Damage to the GPS *antenna* and/or *receiver* can result if the GPS antenna is inadvertently connected to any other RF connector.

3

Figure 3-12: CSM MMI Terminal Connection

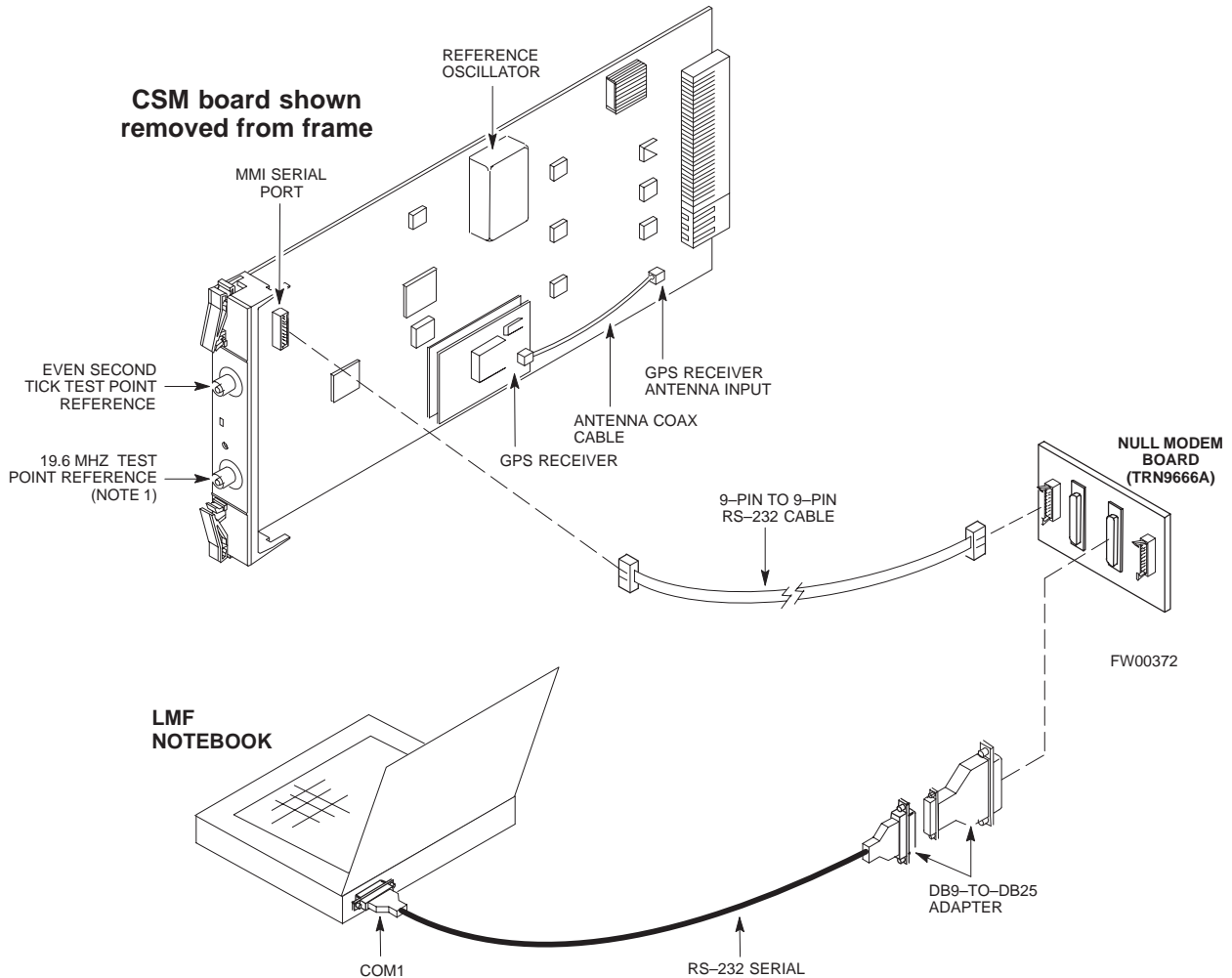

**NOTES:**

- One LED on each CSM:  
 Green = IN-SERVICE ACTIVE  
 Fast Flashing Green = OOS-RAM  
 Red = Fault Condition  
 Flashing Green & Red = Fault

**GPS Initialization/Verification**

Follow the steps outlined in Table 3-19 to connect to CSM-1 installed in the SCCP shelf, verifying that it is functioning normally.

**Table 3-19: GPS Initialization/Verification**

Step	Action
1	<p>To verify that Clock alarms (0000), Dpll is locked and has a reference source, and GPS self test passed messages are displayed within the report, issue the following MMI command</p> <p><b>bstatus</b></p> <p>– Observe the following typical response:</p> <pre>CSM Status INS:ACTIVE Slot A Clock MASTER.   BDC_MAP:000, This CSM's BDC Map:0000</pre> <p><u>Clock Alarms (0000):</u></p> <pre>DPLL is locked and has a reference source. GPS receiver self test result: passed</pre> <p>Time since reset 0:33:11, time since power on: 0:33:11</p>
2	<p>Enter the following command at the CSM&gt; prompt to display the current status of the Loran and the GPS receivers.</p> <p><b>sources</b></p> <p>– Observe the following typical response for systems equipped with LFR:</p> <pre>N Source Name Type TO Good Status Last Phase Target Phase Valid ----- 0 LocalGPS Primary 4 YES Good 0 0 Yes 1 LFR CHA Secondary 4 YES Good -2013177 -2013177 Yes 2 Not Used</pre> <p><u>Current reference source number: 0</u></p> <p>– Observe the following typical response for systems equipped with HSO:</p> <pre>Num Source Name Type TO Good Status Last Phase Target Phase Valid ----- 0 Local GPS Primary 4 Yes Good 3 0 Yes 1 HSO Backup 4 No N/A timed-out* Timed-out* No</pre> <p><b>*NOTE</b> “Timed-out” should only be displayed while the HSO is warming up. “Not-Present” or “Faulty” should not be displayed. If the HSO does not appear as one of the sources, then configure the HSO as a back-up source by entering the following command at the CSM&gt; prompt:</p> <p><b>ss 1 12</b></p> <p>After a maximum of 15 minutes, the Rubidium oscillator should reach operational temperature and the LED on the HSO should now have changed from red to green. After the HSO front panel LED has changed to green, enter <b>sources &lt;cr&gt;</b> at the CSM&gt; prompt. Verify that the HSO is now a valid source by confirming that the bold text below matches the response of the “sources” command.</p> <p>The HSO should be valid within one (1) minute, assuming the DPLL is locked and the HSO rubidium oscillator is fully warmed.</p> <pre>Num Source Name Type TO Good Status Last Phase Target Phase Valid ----- 0 Local GPS Primary 4 Yes Good 3 0 Yes 1 HSO Backup 4 Yes N/A xxxxxxxxxxxx xxxxxxxxxxxx Yes</pre>

... continued on next page

**Table 3-19:** GPS Initialization/Verification

Step	Action
3	<p>HSO information (underlined text above, verified from left to right) is usually the #1 reference source. If this is not the case, have the <i>OMCR</i> determine the correct BTS timing source has been identified in the database by entering the <b>display bts csmgen</b> command and correct as required using the <b>edit csm csmgen refsrc</b> command.</p> <p><b>* IMPORTANT</b>                      If any of the above mentioned areas fail, verify:</p> <ul style="list-style-type: none"> <li>– If LED is RED, verify that HSO had been powered up for at least 5 minutes. After oscillator temperature is stable, LED should go GREEN <i>Wait for this to occur before continuing !</i></li> <li>– If “timed out” is displayed in the Last Phase column, suspect the HSO output buffer or oscillator is defective</li> <li>– Verify the HSO is FULLY SEATED and LOCKED to prevent any possible board warpage</li> </ul>
4	<p>Verify the following GPS information (underlined text above):</p> <ul style="list-style-type: none"> <li>– GPS information is usually the 0 reference source.</li> <li>– At least one Primary source must indicate “Status = good” and “Valid = yes” to bring site up.</li> </ul>

. . . continued on next page

3

**Table 3-19: GPS Initialization/Verification**

Step	Action
5	<p>Enter the following command at the CSM&gt; prompt to verify that the GPS receiver is in tracking mode.</p> <p><b>gstatus</b></p> <p>– Observe the following typical response:</p> <pre> 24:06:08 <u>GPS Receiver Control Task State: tracking satellites.</u> 24:06:08 Time since last valid fix: 0 seconds. 24:06:08 24:06:08 Recent Change Data: 24:06:08 Antenna cable delay 0 ns. 24:06:08 Initial position: lat 117650000 msec, lon -350258000 msec, height 0 cm (GPS) 24:06:08 Initial position accuracy (0): estimated. 24:06:08 24:06:08 GPS Receiver Status: 24:06:08 Position hold: lat 118245548 msec, lon -350249750 msec, height 20270 cm 24:06:08 Current position: lat 118245548 msec, lon -350249750 msec, height 20270 cm (GPS) 24:06:08 <u>8 satellites tracked, receiving 8 satellites, 8 satellites visible.</u> 24:06:08 <u>Current Dilution of Precision (PDOP or HDOP): 0.</u> 24:06:08 Date &amp; Time: 1998:01:13:21:36:11 24:06:08 GPS Receiver Status Byte: 0x08 24:06:08 Chan:0, SVID: 16, Mode: 8, RSSI: 148, Status: 0xa8 24:06:08 Chan:1, SVID: 29, Mode: 8, RSSI: 132, Status: 0xa8 24:06:08 Chan:2, SVID: 18, Mode: 8, RSSI: 121, Status: 0xa8 24:06:08 Chan:3, SVID: 14, Mode: 8, RSSI: 110, Status: 0xa8 24:06:08 Chan:4, SVID: 25, Mode: 8, RSSI: 83, Status: 0xa8 24:06:08 Chan:5, SVID: 3, Mode: 8, RSSI: 49, Status: 0xa8 24:06:08 Chan:6, SVID: 19, Mode: 8, RSSI: 115, Status: 0xa8 24:06:08 Chan:7, SVID: 22, Mode: 8, RSSI: 122, Status: 0xa8 24:06:08 24:06:08 GPS Receiver Identification: 24:06:08 COPYRIGHT 1991-1996 MOTOROLA INC. 24:06:08 SFTW P/N # 98-P36830P 24:06:08 SOFTWARE VER # 8 24:06:08 SOFTWARE REV # 8 24:06:08 SOFTWARE DATE 6 AUG 1996 24:06:08 MODEL # B3121P1115 24:06:08 HDWR P/N # _ 24:06:08 SERIAL # SSG0217769 24:06:08 MANUFACTUR DATE 6B07 24:06:08 OPTIONS LIST IB 24:06:08 The receiver has 8 channels and is equipped with TRAIM.                 </pre>
6	<p><b>Verify</b> the following GPS information (shown above in <u>underlined</u> text):</p> <ul style="list-style-type: none"> <li>– At least 4 satellites are tracked, and 4 satellites are visible.</li> <li>– GPS Receiver Control Task State is “tracking satellites”. <b><i>Do not continue until this occurs!</i></b></li> <li>– Dilution of Precision indication is not more that 30.</li> </ul> <p><b>Record</b> the current position base site latitude, longitude, height and height reference (height reference to Mean Sea Level (MSL) or GPS height (GPS). (GPS = 0 MSL = 1).</p>

... continued on next page



3

Table 3-19: GPS Initialization/Verification	
Step	Action
7	<p><b>If steps 1 through 6 pass, the GPS is good.</b></p> <p><b>* IMPORTANT</b></p> <p>If any of the above mentioned areas fail, verify that:</p> <ul style="list-style-type: none"> <li>– If <i>Initial position accuracy</i> is “estimated” (typical), at least 4 satellites must be tracked and visible (1 satellite must be tracked and visible if actual lat, log, and height data for this site has been entered into CDF file).</li> <li>– If <i>Initial position accuracy</i> is “surveyed,” position data currently in the CDF file is assumed to be accurate. GPS will not automatically survey and update its position.</li> <li>– The GPS antenna is not obstructed or misaligned.</li> <li>– GPS antenna connector center conductor measures approximately +5 Vdc with respect to the shield.</li> <li>– There is no more than 4.5 dB of loss between the GPS antenna OSX connector and the BTS frame GPS input.</li> <li>– Any lightning protection installed between GPS antenna and BTS frame is installed correctly.</li> </ul>
8	<p>Enter the following commands at the CSM&gt; prompt to verify that the CSM is warmed up and that GPS acquisition has taken place.</p> <p><b>debug dpllp</b></p> <p>Observe the following typical response if the CSM is not warmed up (15 minutes from application of power) (<i>If warmed-up proceed to step 9</i>)</p> <pre>CSM&gt;DPLL Task Wait. 884 seconds left. DPLL Task Wait. 882 seconds left. DPLL Task Wait. 880 seconds left. ....etc.</pre> <p><b>NOTE</b></p> <p>The <b>warm</b> command can be issued at the MMI port used to force the CSM into warm-up, but the reference oscillator will be unstable.</p>
9	<p>Observe the following typical response if the CSM is warmed up.</p> <pre>c:17486 off: <u>-11</u>, 3, <u>6</u> <u>TK SRC:0</u> S0: 3 S1:-2013175,-2013175 c:17486 off: <u>-11</u>, 3, <u>6</u> <u>TK SRC:0</u> S0: 3 S1:-2013175,-2013175 c:17470 off: <u>-11</u>, 1, <u>6</u> <u>TK SRC:0</u> S0: 1 S1:-2013175,-2013175 c:17486 off: <u>-11</u>, 3, <u>6</u> <u>TK SRC:0</u> S0: 3 S1:-2013175,-2013175 c:17470 off: <u>-11</u>, 1, <u>6</u> <u>TK SRC:0</u> S0: 1 S1:-2013175,-2013175 c:17470 off: <u>-11</u>, 1, <u>6</u> <u>TK SRC:0</u> S0: 1 S1:-2013175,-2013175</pre>
10	<p>Verify the following GPS information (underlined text above, from left to right):</p> <ul style="list-style-type: none"> <li>– Lower limit offset from tracked source variable is not less than -60 (equates to 3µs limit).</li> <li>– Upper limit offset from tracked source variable is not more than +60 (equates to 3µs limit).</li> <li>– TK SRC: 0 is selected, where SRC 0 = GPS.</li> </ul>
11	<p>Enter the following commands at the CSM&gt; prompt to exit the debug mode display.</p> <p><b>debug dpllp</b></p>

LORAN-C  
Initialization/Verification

Table 3-20: LORAN-C Initialization/Verification

Step	Action	Note
1	<p>At the CSM&gt; prompt, enter <b>lstatus &lt;cr&gt;</b> to verify that the LFR is in tracking mode. A typical response is:</p> <pre> CSM&gt; lstatus &lt;cr&gt; LFR Station Status: Clock coherence: 512 _____&gt; 5930M 51/60 dB 0 S/N Flag: 5930X 52/64 dn -1 S/N Flag: 5990 47/55 dB -6 S/N Flag: 7980M 62/66 dB 10 S/N Flag: <b>7980W</b> 65/69 dB <b>14</b> S/N Flag: . <b>PLL Station</b> . _____&gt; 7980X 48/54 dB -4 S/N Flag: 7980Y 46/58 dB -8 S/N Flag:E 7980Z 60/67 dB 8 S/N Flag: 8290M 50/65 dB 0 S/N Flag: 8290W 73/79 dB 20 S/N Flag: 8290W 58/61 dB 6 S/N Flag: 8970M 89/95 dB 29 S/N Flag: 8970W 62/66 dB 10 S/N Flag: 8970X 73/79 dB 22 S/N Flag: 8970Y 73/79 dB 19 S/N Flag: 8970Z 62/65 dB 10 S/N Flag: 9610M 62/65 dB 10 S/N Flag: 9610V 58/61 dB 8 S/N Flag: 9610W 47/49 dB -4 S/N Flag:E 9610X 46/57 dB -5 S/N Flag:E 9610Y 48/54 dB -5 S/N Flag:E 9610Z 65/69 dB 12 S/N Flag: 9940M 50/53 dB -1 S/N Flag:S 9940W 49/56 dB -4 S/N Flag:E 9940Y 46/50 dB-10 S/N Flag:E 9960M 73/79 dB 22 S/N Flag: 9960W 51/60 dB 0 S/N Flag: 9960X 51/63 dB -1 S/N Flag: 9960Y 59/67 dB 8 S/N Flag: 9960Z 89/96 dB 29 S/N Flag:  LFR Task State: lfr locked to station 7980W LFR Recent Change Data:   Search List: 5930 5990 7980 8290 8970 9940 9610 9960 _____&gt;   PLL GRI: 7980W LFR Master, reset not needed, not the reference source. CSM&gt;                     </pre>	<p><i>This must be greater than 100 before LFR becomes a valid source.</i></p> <p><i>This shows the LFR is locked to the selected PLL station.</i></p> <p><i>This search list and PLL data must match the geographical location of the cell site.</i></p>

... continued on next page



3

**Table 3-20:** LORAN–C Initialization/Verification

Step	Action	Note
2	Verify the following LFR information (highlighted above in <b>boldface</b> type): <ul style="list-style-type: none"> <li>– Locate the “dot” that indicates the current phase locked station assignment (assigned by MM).</li> <li>– Verify that the station call letters are as specified in site documentation as well as M X Y Z assignment.</li> <li>– Verify the S/N ratio of the phase locked station is greater than 8.</li> </ul>	
3	At the CSM> prompt, enter <b>sources &lt;cr&gt;</b> to display the current status of the the LORAN receiver. <ul style="list-style-type: none"> <li>– Observe the following typical response.</li> </ul> <pre>                     Num  Source Name  Type      TO  Good  Status  Last Phase  Target Phase Valid                     -----                     0   Local GPS     Primary   4   Yes   Good    -3          0          Yes                     1   LFR ch A      Secondary 4   <u>Yes</u>  <u>Good</u>  -2013177  -2013177  <u>Yes</u>                     2   Not used                     <b>Current reference source number: 1</b>                     </pre>	
4	LORAN LFR information (highlighted above in <b>boldface</b> type) is usually the #1 reference source (verified from left to right). <p><b>* IMPORTANT</b></p> If any of the above mentioned areas fail, verify: <ul style="list-style-type: none"> <li>– The LFR antenna is not obstructed or misaligned.</li> <li>– The antenna pre–amplifier power and calibration twisted pair connections are intact and &lt; 91.4 m (300 ft) in length.</li> <li>– A dependable connection to suitable Earth Ground is in place.</li> <li>– The search list and PLL station for cellsite location are correctly configured .</li> </ul> <p><b>NOTE</b></p> LFR functionality should be verified using the “source” command (as shown in Step 3). Use the <u>underlined</u> responses on the LFR row to validate correct LFR operation.	
5	Close the hyperterminal window.	



## Test Equipment Setup

### Connecting Test Equipment to the BTS

All test equipment is controlled by the LMF via IEEE-488/GPIB bus. The LMF requires each piece of test equipment to have a factory set GPIB address. If there is a communications problem between the LMF and any piece of test equipment, verify that the GPIB addresses have been set correctly (normally 13 for a power meter and 18 for a CDMA analyzer).

The following test equipment is required to perform optimization, calibration and ATP tests:

- LMF
- Test set
- Directional coupler and attenuator
- RF cables and connectors

Refer to Table 3-21 for an overview of connections for test equipment currently supported by LMF. In addition, see the following figures:

- Figure 3-14 and Figure 3-15 show the test set connections for TX calibration
- Figure 3-16 and Figure 3-17 show the test set connections for optimization/ATP tests

### Supported Test Sets

Optimization and ATP testing may be performed using one of the following test sets:

- CyberTest
- Advantest R3465 and HP-437B or Gigatronics Power Meter
- Hewlett-Packard HP 8935
- Hewlett-Packard HP 8921 (W/CDMA and PCS Interface (1.9 GHz) and HP-437B or Gigatronics Power Meter
- Spectrum Analyzer (HP8594E) – *optional*
- Rubidium Standard Timebase – *optional*



#### CAUTION

To prevent damage to the test equipment, all transmit (TX) test connections must be through the 30 dB directional coupler for an 800 MHz BTS and the 30dB directional coupler plus a 20dB in-line attenuator for a 1.9 GHz BTS.

Test Equipment Setup Chart

Table 3-21 depicts the current test equipment available meeting Motorola standards.

To identify the connection ports, locate the test equipment presently being used in the **TEST SETS** columns, and read down the column. Where a ball appears in the column, connect one end of the test cable to that port. Follow the horizontal line to locate the end connection(s), reading up the column to identify the appropriate equipment/BTS port.

**Table 3-21: Test Equipment Setup**

SIGNAL	TEST SETS					ADDITIONAL TEST EQUIPMENT				BTS	
	Cyber-Test	Advantest	HP 8935	HP 8921A	HP 8921 W/PCS	Power Meter	GPIB Interface	LMF	Directional Coupler & Pad*		
EVEN SECOND SYNCHRONIZATION	EVEN SEC REF	EVEN SEC SYNC IN	EVEN SECOND SYNC IN	EVEN SECOND SYNC IN	EVEN SECOND SYNC IN					SYNC MONITOR	
19.6608 MHZ CLOCK	TIME BASE IN	CDMA TIME BASE IN	EXT REF IN	CDMA TIME BASE IN	CDMA TIME BASE IN					FREQ MONITOR	
CONTROL IEEE 488 BUS	IEEE 488	GPIB	HP-IB	HP-IB	HP-IB	HP-IB	GPIB	SERIAL PORT			
TX TEST CABLES	RF IN/OUT	INPUT 50-OHM	RF IN/OUT	RF IN/OUT	RF IN/OUT				20 DB PAD	BTS PORT	TX1-6
RX TEST CABLES	RF IN/OUT	RF OUT 50-OHM	DUPLEX	DUPLEX OUT	RF OUT ONLY						RX1-12

3

### Equipment Warm-up



#### IMPORTANT

Warm-up *BTS equipment for a minimum of 60 minutes* prior to performing the BTS optimization procedure. This assures BTS site stability and contributes to optimization accuracy. (Time spent running initial power-up, hardware/firmware audit, and BTS download counts as warm-up time.)



#### WARNING

Before installing any test equipment directly to any BTS **TX OUT** connector, verify there are **NO** CDMA BBX channels keyed. At active sites, have the OMC-R/CBSC place the antenna (sector) assigned to the LPA under test OOS. Failure to do so can result in serious personal injury and/or equipment damage.

### Cable Calibration Setup

Figure 3-13 shows the cable calibration setup for various supported test sets. The left side of the diagram depicts the location of the input and output ports of each test set, and the right side details the set up for each test. Table 3-25 provides a procedure for calibrating cables.

Figure 3-13: Cable Calibration Test Setup

SUPPORTED TEST SETS

Motorola CyberTest

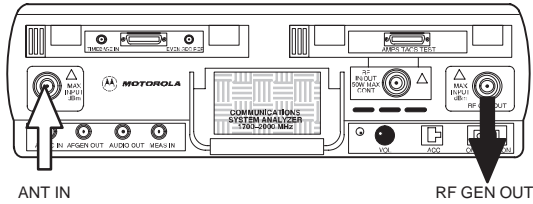

**Note:** The Directional Coupler is not used with the CyberTest Test Set. The TX cable is connected directly to the CyberTest Test Set.

A 10dB attenuator must be used with the short test cable for cable calibration with the CyberTest Test Set. The 10dB attenuator is used only for the cable calibration procedure, not with the test cables for TX calibration and ATP tests.

Hewlett-Packard Model HP 8935

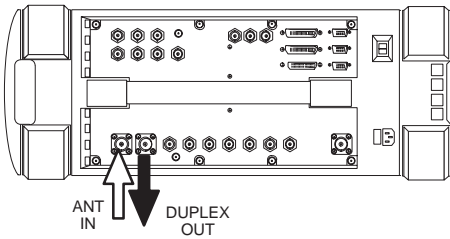

Advantest Model R3465

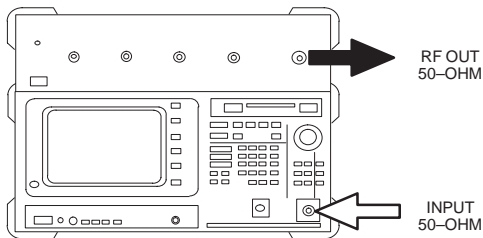

Hewlett-Packard Model HP 8921A

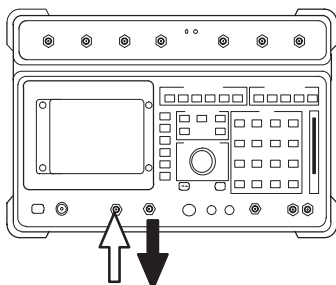

**Note:** For 800 MHz only. The HP8921A cannot be used to calibrate cables for PCS frequencies.

FW00089

CALIBRATION SET UP

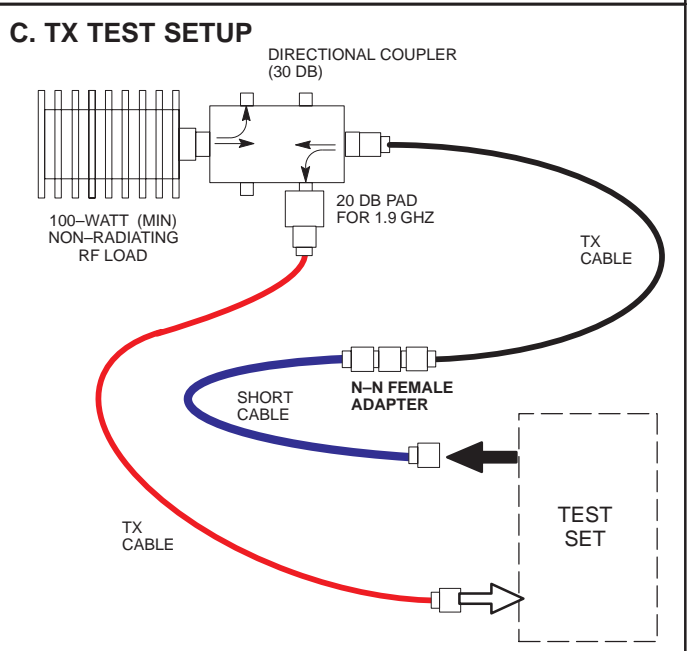
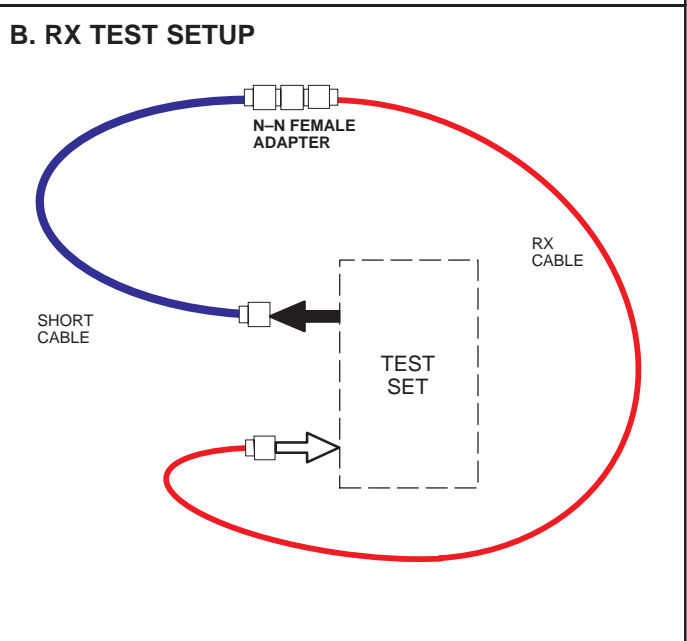
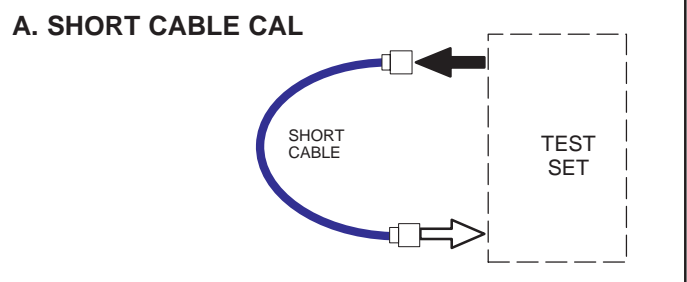

# Test Equipment Set-up – continued

## Setup for TX Calibration

Figure 3-14 and Figure 3-15 show the test set connections for TX calibration.

**Figure 3-14: TX Calibration Test Setup (CyberTest and HP 8935)**

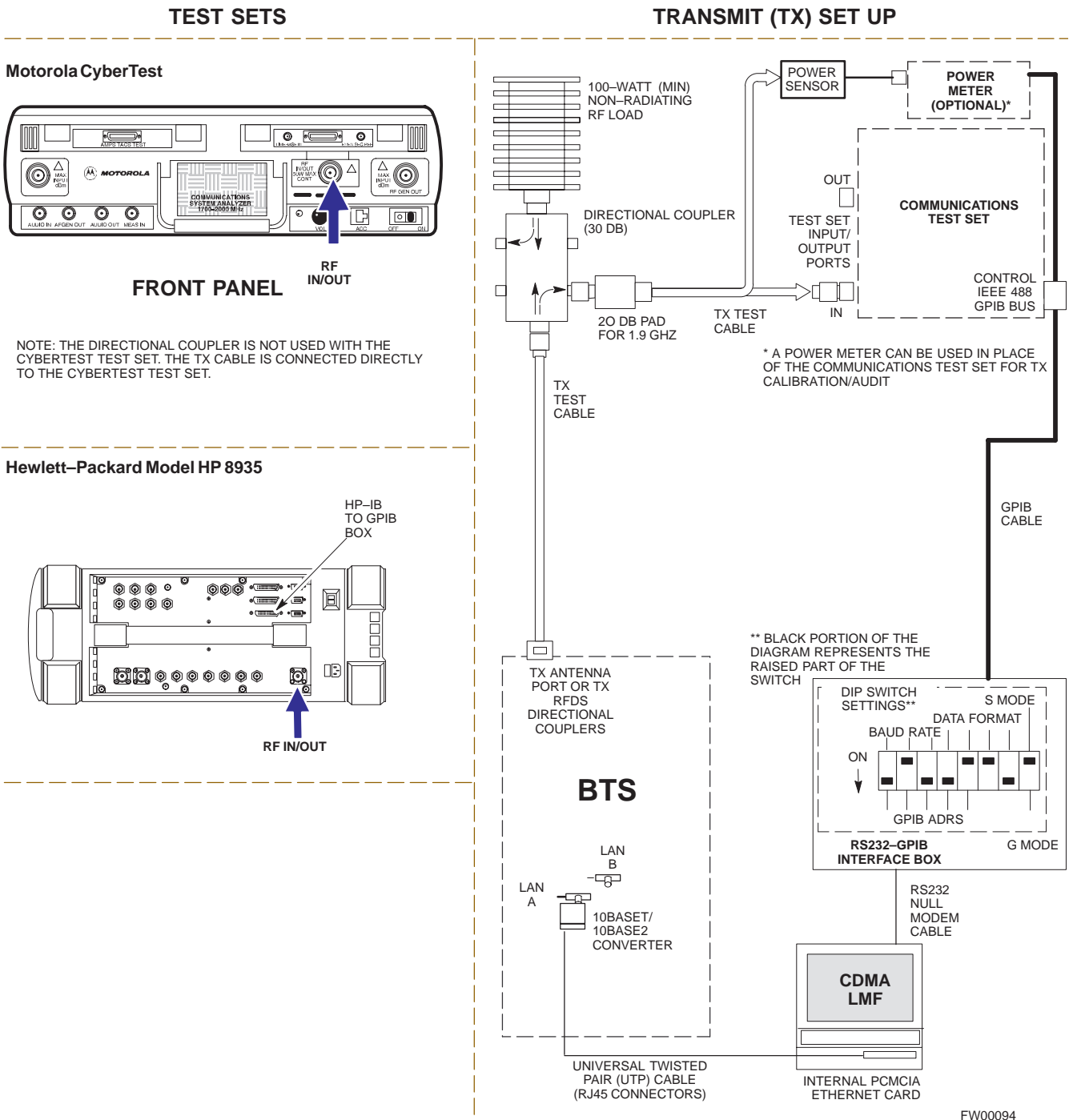
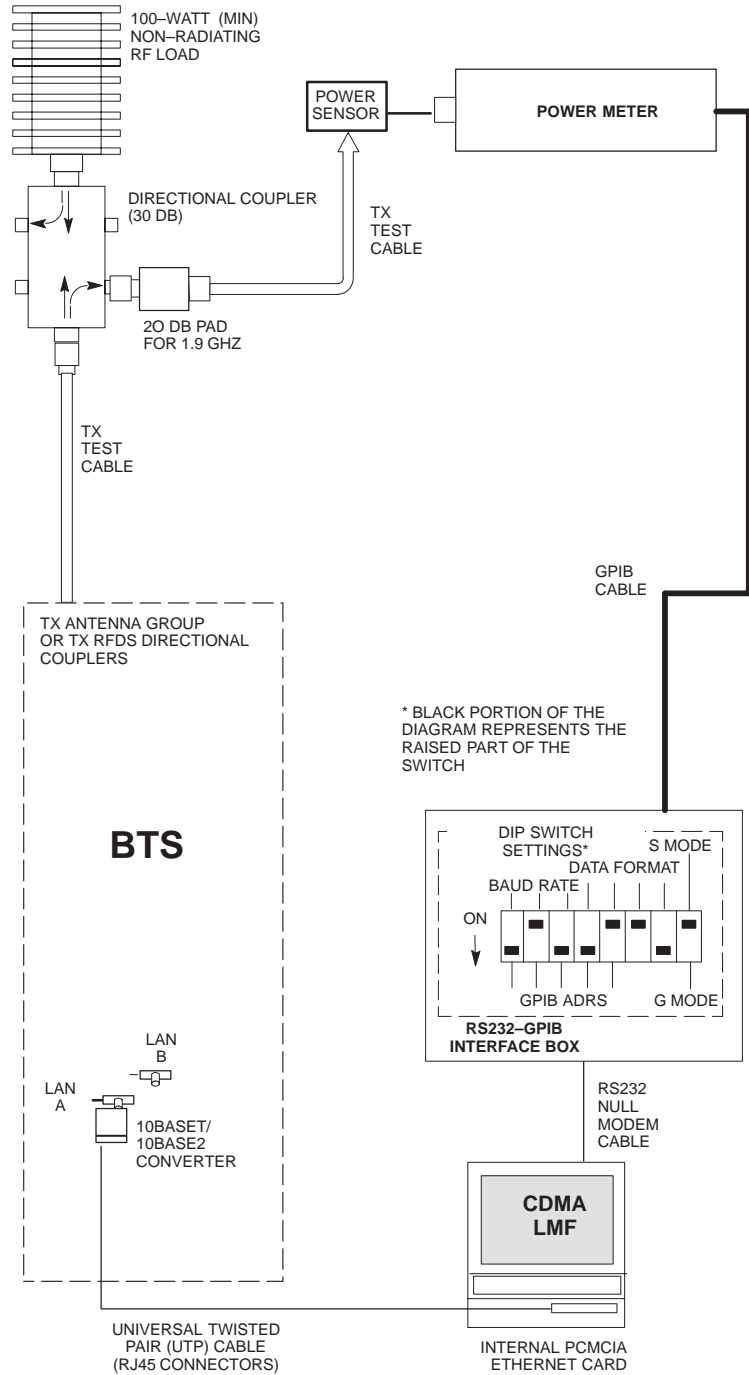

Figure 3-15: TX Calibration Test Setup HP 8921A and Advantest

TEST SETS

TRANSMIT (TX) SET UP

NOTE: THE HP8921A AND ADVANTEST **CANNOT** BE USED FOR TX CALIBRATION. A POWER METER MUST BE USED.



3

Setup for Optimization/ATP

Figure 3-16 and Figure 3-17 show the test set connections for optimization/ATP tests.

Figure 3-16: Optimization/ATP Test Setup Calibration (CyberTest, HP 8935 and Advantest)

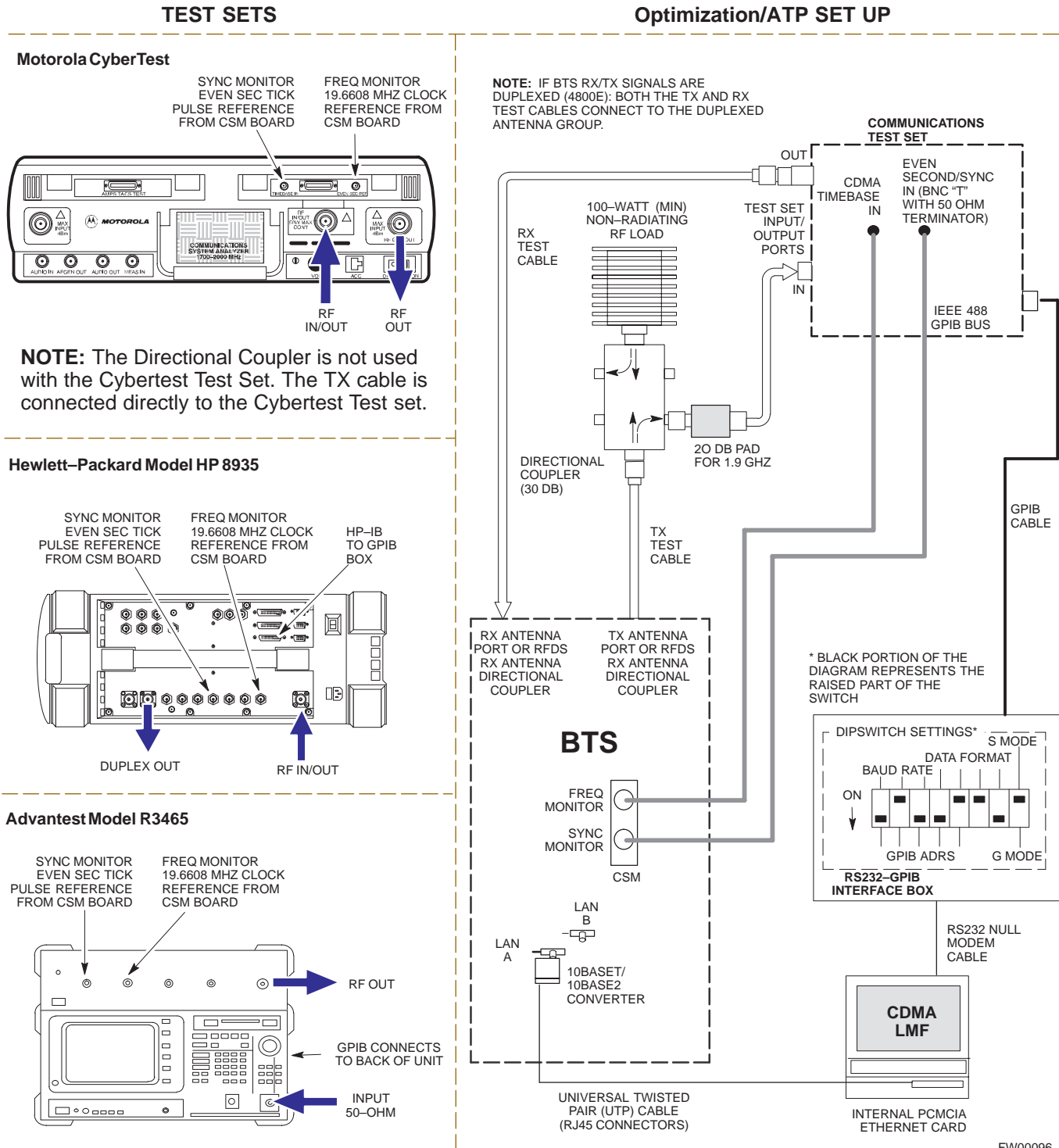

Figure 3-17: Optimization/ATP Test Setup HP 8921A

TEST SETS

Hewlett-Packard Model HP 8921A W/PCS Interface (for 1700 and 1900 MHz)

SYNC MONITOR  
EVEN SEC TICK  
PULSE REFERENCE  
FROM CSM BOARD

FREQ MONITOR  
19.6608 MHZ CLOCK  
REFERENCE FROM  
CSM BOARD

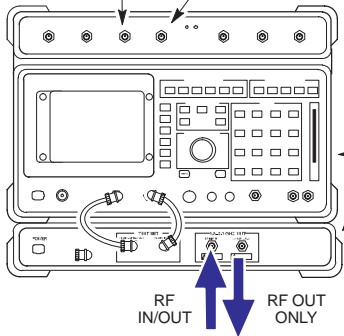

Hewlett-Packard Model HP 8921A (for 800 MHz)

SYNC MONITOR  
EVEN SEC TICK  
PULSE REFERENCE  
FROM CSM BOARD

FREQ MONITOR  
19.6608 MHZ CLOCK  
REFERENCE FROM  
CSM BOARD

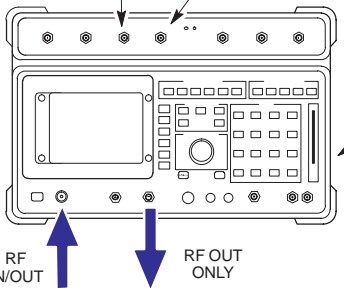

Optimization/ATP SET UP

NOTE: IF BTS RX/TX SIGNALS ARE DUPLEXED (4800E): BOTH THE TX AND RX TEST CABLES CONNECT TO THE DUPLEXED ANTENNA GROUP.

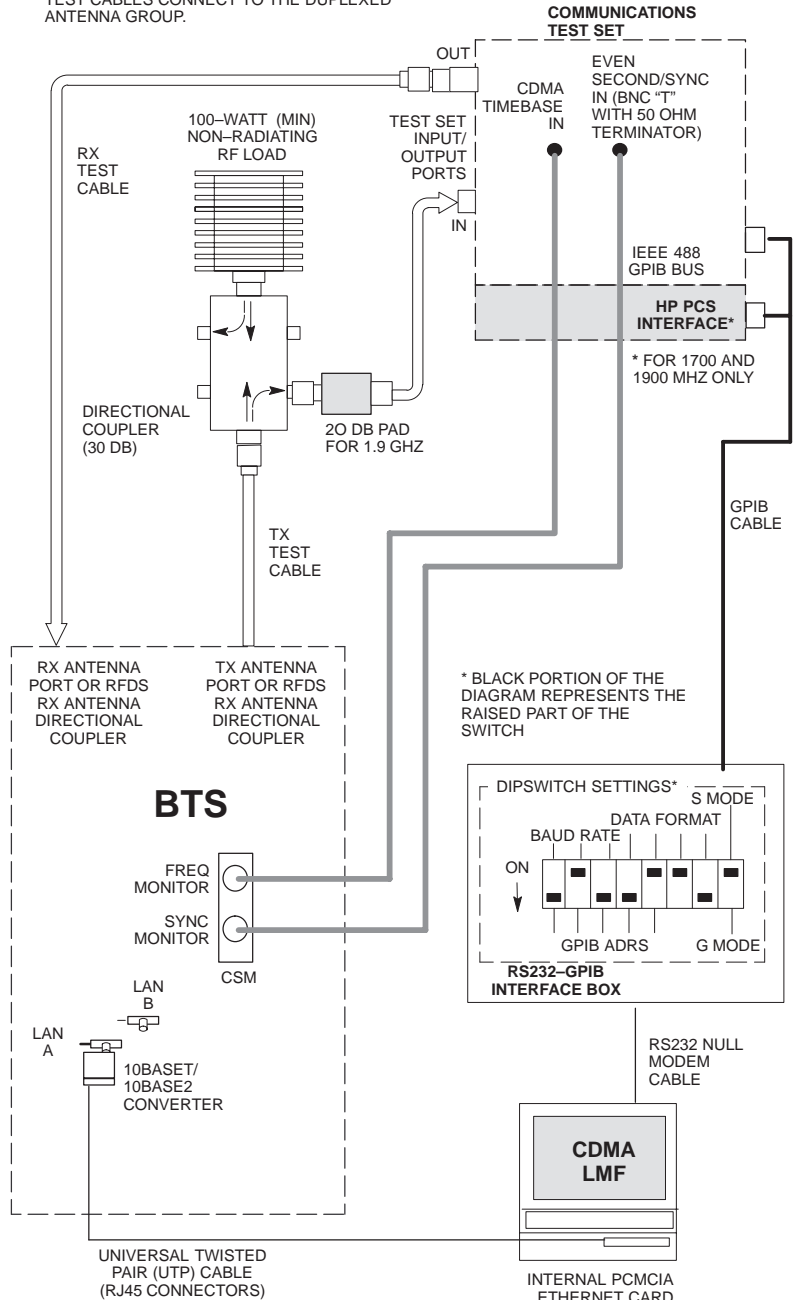

REF FW00097



---

# Test Set Calibration

## Background

Proper test equipment setup ensures that the test equipment and associated test cables do not introduce measurement errors, and that measurements are correct.

### NOTE

If the test set being used to interface with the BTS has been calibrated and maintained as a set, this procedure does not need to be performed. (Test Set includes LMF terminal, communications test set, additional test equipment, associated test cables, and adapters.)

This procedure must be performed *prior* to beginning the optimization. Verify all test equipment (including all associated test cables and adapters actually used to interface all test equipment and the BTS) has been calibrated and maintained as a set.



### CAUTION

If any piece of test equipment, test cable, or RF adapter, that makes up the calibrated test equipment set, has been replaced, re-calibration must be performed. Failure to do so can introduce measurement errors, resulting in incorrect measurements and degradation to system performance.



### IMPORTANT

Calibration of the communications test set (or equivalent test equipment) must be performed at the site before calibrating the overall test set. Calibrate the test equipment *after* it has been allowed to warm-up and stabilize for a *minimum of 60 minutes*.

## Purpose

These procedures access the CDMA LMF automated calibration routine used to determine the path losses of the supported communications analyzer, power meter, associated test cables, and (if used) antenna switch that make up the overall calibrated test set. After calibration, the gain/loss offset values are stored in a test measurement offset file on the CDMA LMF.

### Selecting Test Equipment

Use **LMF Options** from the **Options** menu list to select test equipment automatically (using the autodetect feature) or manually.

#### Prerequisites

A **Serial Connection** and a **Network Connection** tab are provided for test equipment selection. The **Serial Connection** tab is used when the test equipment items are connected directly to the CDMA LMF computer via a GPIB box (normal setup). The **Network Connection** tab is used when the test equipment is to be connected remotely via a network connection.

Ensure the following has been completed before selecting test equipment:

- Test equipment is correctly connected and turned on.
- CDMA LMF computer serial port and test equipment are connected to the GPIB box.

#### Manually Selecting Test Equipment in a Serial Connection Tab

Test equipment can be manually specified before, or after, the test equipment is connected. CDMA LMF does not check to see if the test equipment is actually detected for manual specification.

**Table 3-22:** Selecting Test Equipment Manually in a Serial Connection Tab

Step	Action
1	From the <b>Options</b> menu, select <b>LMF Options</b> . The <b>LMF Options</b> window appears.
2	Click on the <b>Serial Connection</b> tab (if not in the forefront).
3	Select the correct serial port in the <b>COMM Port</b> pick list (normally <b>COM1</b> ).
4	Click on the <b>Manual Specification</b> button (if not enabled).
5	Click on the check box corresponding to the test item(s) to be used.
6	Type the GPIB address in the corresponding <b>GPIB address</b> box. <i>Recommended Addresses</i> 13=Power Meter 18=CDMA Analyzer
7	Click on <b>Apply</b> . (The button will darken until the selection has been committed.)  <b>NOTE</b> With manual selection, CDMA LMF does not detect the test equipment to see if it is connected and communicating with CDMA LMF.
8	Click on <b>Dismiss</b> to close the test equipment window.



**Automatically Selecting Test Equipment in a Serial Connection Tab**

When using the auto-detection feature to select test equipment, the CDMA LMF examines which test equipment items are actually communicating with CDMA LMF. Follow the procedure in Table 3-23 to use the auto-detect feature.

**Table 3-23: Selecting Test Equipment Using Auto-Detect**

Step	Action
1	From the <b>Options</b> menu, select <b>LMF Options</b> . The <b>LMF Options</b> window appears.
2	Click on the <b>Serial Connection</b> tab (if not in the forefront).
3	Select the correct serial port in the <b>COMM Port</b> pick list (normally <b>COM1</b> ).
4	Click on <b>Auto-Detection</b> (if not enabled).
5	Type in the GPIB addresses in the box labeled <b>GPIB address to search</b> (if not already displayed). <b>NOTE</b> When both a power meter and analyzer are selected, the first item listed in the <b>GPIB addresses to search</b> box will be used for RF power measurements (i.e., TX calibration). The address for a power meter is normally <b>13</b> and the address for a CDMA analyzer is normally <b>18</b> . If <b>13,18</b> is included in the <b>GPIB addresses to search</b> box, the power meter (13) will be used for RF power measurements. If the test equipment items are manually selected the CDMA analyzer is used only if a power meter is not selected.
6	Click <b>Apply</b> . The button will darken until the selection has been committed. A check mark will appear in the <b>Manual Configuration</b> section for detected test equipment items.
7	Click <b>Dismiss</b> to close the <b>LMF Options</b> window.



**Calibrating Test Equipment**

The calibrate test equipment function zeros the power measurement level of the test equipment item that is to be used for TX calibration and audit. If both a power meter and an analyzer are connected, only the power meter is zeroed.

**Calibrate Test Equipment** from the **Util** menu list is used to calibrate test equipment item *before* being used for testing. The test equipment must be selected before beginning calibration. Follow the procedure in Table 3-24 to calibrate the test equipment.

<b>Table 3-24: Test Equipment Calibration</b>	
<b>Step</b>	<b>Action</b>
1	From the <b>Util</b> menu, select <b>Calibrate Test Equipment</b> . A <b>Directions</b> window is displayed. Follow the instructions provided.
2	Follow the direction provided.
3	Click on <b>Continue</b> to close the <b>Directions</b> window. A status window is displayed.
4	Click on <b>OK</b> to close the status report window.

**Calibrating Cables**

The cable calibration function is used to measure the loss (in dB) for the TX and RX cables that are to be used for testing. A CDMA analyzer is used to measure the loss of each cable configuration (TX cable configuration and RX cable configuration). The cable calibration consists of the following steps.

- Measure the loss of a short cable. This is done to compensate for any measurement error of the analyzer. The short cable, which is used only for the calibration process, is used in series with both the TX and RX cable configuration when they are measured. The measured loss of the short cable is deducted from the measured loss of the TX and RX cable configuration to determine the actual loss of the TX and RX cable configurations. This deduction is done so any error in the analyzer measurement will be adjusted out of both the TX and RX measurements.
- The short cable plus the RX cable configuration loss is measured. The RX cable configuration normally consists only of a coax cable with type-N connectors that is long enough to reach from the BTS RX port the test equipment.
- The short cable plus the TX cable configuration loss is measured. The TX cable configuration normally consists of two coax cables with type-N connectors and a directional coupler, a load, and an additional attenuator if required by the BTS type. The total loss of the path loss of the TX cable configuration must be as required for the BTS (normally 30 or 50 dB). The Motorola Cyber test analyzer is different in that the required attenuation/load is built into the test set so the TX cable configuration consists only of the required length coax cable.



**Calibrating Cables with a CDMA Analyzer**

The **Cable Calibration** menu item from the **Util** menu list is used to calibrate both TX and RX test cables for use with CDMA LMF.

**NOTE**

LMF cable calibration cannot be accomplished with an HP8921A analyzer for 1.9 MHz. A different analyzer type or the signal generator and spectrum analyzer method must be used (refer to Table 3-26 and Table 3-27). Cable calibration values must be manually entered if the signal generator and spectrum analyzer method is used. For the HP8921A, refer to Appendix F.

The test equipment must be selected before this procedure can be started. Follow the procedure in Table 3-25 to calibrate the cables. Figure 3-13 illustrates the cable calibration test equipment setup.

<b>Table 3-25: Cable Calibration</b>	
<b>Step</b>	<b>Action</b>
1	From the <b>Util</b> menu, select <b>Cable Calibration</b> . A <b>Cable Calibration</b> window is displayed.
2	Enter a channel number(s) in the <b>Channels</b> box. Multiple channels numbers must be separated with a comma, no space (i.e., 200,800). When two or more channels numbers are entered, the cables will be calibrated for each channel. Interpolation will be accomplished for other channels as required for TX calibration.
3	Select <b>TX and RX CABLE CAL</b> , <b>TX CABLE CAL</b> or <b>RX CABLE CAL</b> in the <b>Cable Calibration</b> picklist.
4	Click <b>OK</b> . Follow the directions displayed for each step. A status report window will be displayed with the results of the cable calibration.

**Calibrating TX Cables Using a Signal Generator and Spectrum Analyzer**

Follow the procedure in Table 3-26 to calibrate the TX cables using the signal generator and spectrum analyzer. Refer to Figure 3-18 for a diagram of the signal generator and spectrum analyzer.

**Table 3-26: Calibrating TX Cables Using Signal Generator and Spectrum Analyzer**

Step	Action
1	Connect a short test cable between the spectrum analyzer and the signal generator.
2	Set signal generator to 0 dBm at the customer frequency of 1840–1870 MHz band for Korea PCS and 1930–1990 MHz band for North American PCS.
3	Use spectrum analyzer to measure signal generator output (see Figure 3-18, “A”) and record the value.
4	Connect the spectrum analyzer’s short cable to point “B”, as shown in the lower portion of the diagram, to measure cable output at customer frequency (1840–1870 MHz for Korea PCS and 1930–1990 MHz for North American PCS) and record the value at point “B”.
5	Calibration factor = A – B Example: Cal = –1 dBm – (–53.5 dBm) = 52.5 dB

**NOTE**  
The short cable is used for *calibration only*. It is *not* part of the final test setup. After calibration is completed, *do not* re-arrange any cables. Use the equipment setup, as is, to ensure test procedures use the correct calibration factor.

**Figure 3-18: Calibrating Test Equipment Setup for TX Cable Calibration (Using Signal Generator and Spectrum Analyzer)**

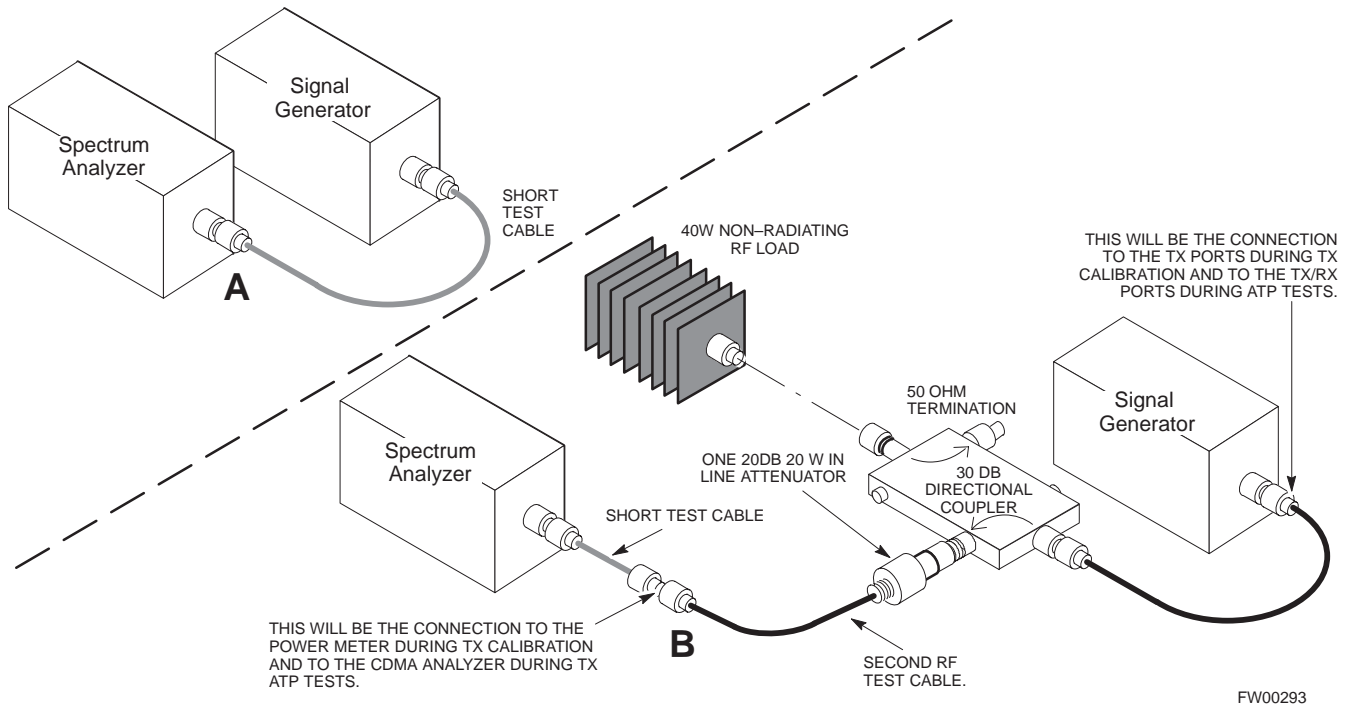

FW00293

**Calibrating RX Cables Using a Signal Generator and Spectrum Analyzer**

Follow the procedure in Table 3-27 to calibrate the RX cables using the signal generator and spectrum analyzer. Refer to Figure 3-19, if required.

Table 3-27: Calibrating RX Cables Using a Signal Generator and Spectrum Analyzer	
Step	Action
1	Connect a short test cable to the spectrum analyzer and connect the other end to the Signal Generator.
2	Set signal generator to -10 dBm at the customer's RX frequency of 1750–1780 MHz for Korean PCS and 1850–1910 MHz band for North American PCS.
3	Use spectrum analyzer to measure signal generator output (see Figure 3-19, "A") and record the value for "A".
4	Connect the test setup, as shown in the lower portion of the diagram, to measure the output at the customer's RX frequency in the 1850–1910 MHz band. Record the value at point "B".
5	Calibration factor = A – B Example: Cal = -12 dBm – (-14 dBm) = 2 dB
<p><b>NOTE</b> The short test cable is used for test equipment setup calibration <i>only</i>. It is not be part of the final test setup. After calibration is completed, <i>do not</i> re-arrange any cables. Use the equipment setup, as is, to ensure test procedures use the correct calibration factor.</p>	

**Figure 3-19:** Calibrating Test Equipment Setup for RX ATP Test (Using Signal Generator and Spectrum Analyzer)

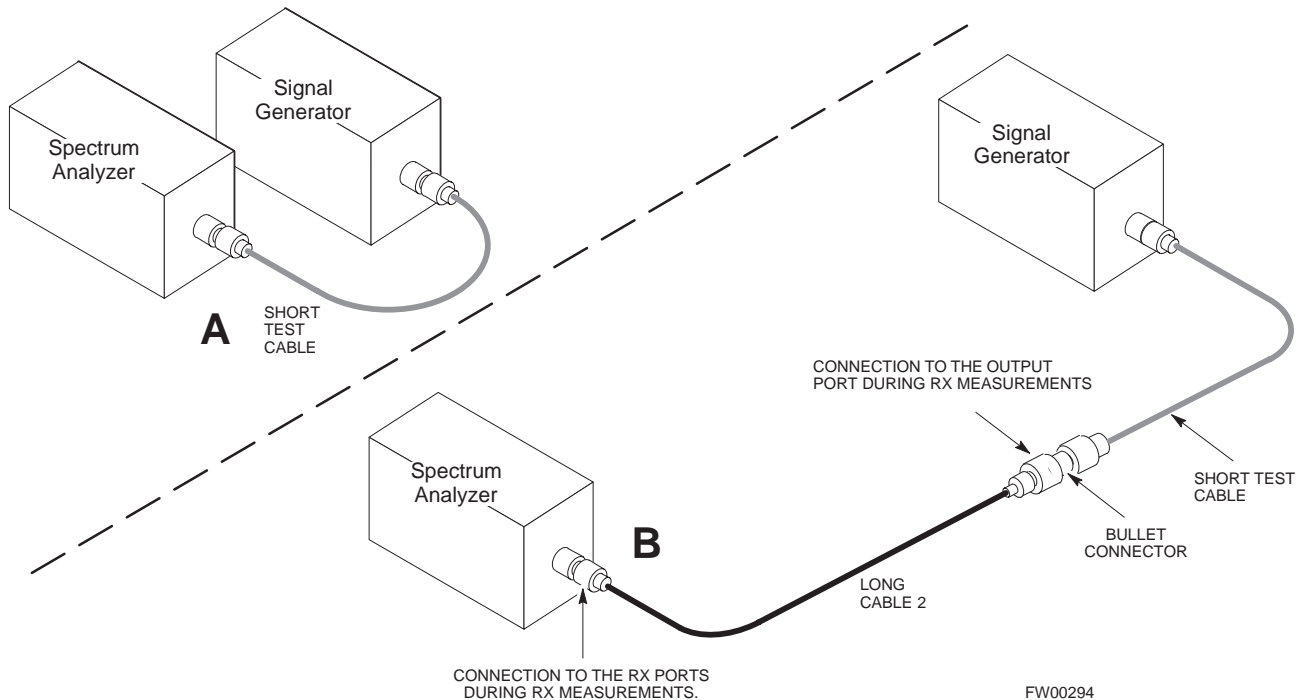

### Setting Cable Loss Values

Cable loss values for the TX and RX test cable configurations are normally set by accomplishing cable calibration with use of the applicable test equipment. The resulting values are stored in the cable loss files. The cable loss values can also be set/changed manually.

#### Prerequisites

- Logged into the BTS

**Table 3-28:** Setting Cable Loss Values

Step	Action
1	Click on the <b>Util</b> menu.
2	Select <b>Edit &gt;Cable Loss &gt; TX or RX</b> . A data entry pop-up window will appear.
3	Click on the <b>Add Row</b> button to add a new channel number. Then click in the <b>Channel #</b> and <b>Loss (dBm)</b> columns and enter the desired values.
4	To edit existing values click in the data box to be changed and change the value.
5	To delete a row, click on the row and then click on the <b>Delete Row</b> button.
6	Click on the <b>Save</b> button to save displayed values.
7	Click on the <b>Dismiss</b> button to exit the window. Values that were entered/changed after the <b>Save</b> button was used will not be saved. <b>NOTE</b> <ul style="list-style-type: none"><li>• If cable loss values exist for two different channels the LMF will interpolate for all other channels.</li><li>• Entered values will be used by the LMF as soon as they are saved. You do not have to logout and login.</li></ul>



**Setting TX Coupler Loss Value**

If an in-service TX coupler is installed the coupler loss (e.g., 30 dB) must be manually entered so it will be included in the LMF TX calibration and audit calculations.

**Prerequisites**

- Logged into the BTS

**Table 3-29: Setting TX Coupler Loss Values**

Step	Action
1	Click on the <b>Util</b> menu.
2	Select <b>Edit &gt;TX Coupler Loss</b> . A data entry pop-up window will appear.
3	Click in the <b>Loss (dBm)</b> column for each carrier that has a coupler and enter the appropriate value.
4	To edit existing values click in the data box to be changed and change the value.
5	Click on the <b>Save</b> button to save displayed values.
6	<p>Click on the <b>Dismiss</b> button to exit the window. Values that were entered/changed after the <b>Save</b> button was used will not be saved.</p> <p><b>NOTE</b></p> <ul style="list-style-type: none"> <li>• The <b>In-Service Calibration</b> check box in the <b>Options&gt;LMF Options&gt;BTS Options</b> tab must be checked before entered TX coupler loss values will be used by the TX calibration and audit functions.</li> <li>• Entered values will be used by the LMF as soon as they are saved. You do not have to logout and login.</li> </ul>

---

# Bay Level Offset Calibration

## Introduction

Calibration compensates for normal equipment variations within the BTS and assures maximum measurement accuracy.

## RF Path Bay Level Offset Calibration

3

Calibration identifies the accumulated gain in every transmit path (BBX2 slot) at the BTS site and stores that value in the CAL file. The BLOs are subsequently downloaded to each BBX2.

Each receive path starts at a BTS RX antenna port and terminates at a backplane BBX2 slot. Each transmit path starts at a BBX2 backplane slot, travels through the LPA, and terminates at a BTS TX antenna port.

Calibration identifies the accumulated gain in every transmit path (BBX2 slot) at the BTS site and stores that value in the CAL file. Each transmit path starts at a C-CCP shelf backplane BBX2 slot, travels through the LPA, and ends at a BTS TX antenna port. When the TX path calibration is performed, the RX path BLO will automatically be set to the default value.

## When to Calibrate BLOs

Calibration of BLOs is required after initial BTS installation.

The BLO data of an operational BTS site must be re-calibrated once each year. Motorola recommends re-calibrating the BLO data for all associated RF paths after replacing any of the following components or associated interconnecting RF cabling:

- BBX2 board
- SCCP shelf
- CIO card
- CIO to LPA backplane RF cable
- LPA backplane
- LPA
- TX filter / TX filter combiner
- TX thru-port cable to the RF Interface Panel

### TX Path Calibration

The TX Path Calibration assures correct site installation, cabling, and the first order functionality of all installed equipment. The proper function of each RF path is verified during calibration. The external test equipment is used to validate/calibrate the TX paths of the BTS.



#### WARNING

*Before* installing any test equipment directly to any **TX OUT** connector you must *first verify that there are no CDMA channels keyed*. Have the OMC-R place the sector assigned to the LPA under test OOS. Failure to do so can result in serious personal injury and/or equipment damage.



#### CAUTION

Always wear a conductive, high impedance wrist strap while handling any circuit card/module. If this is not done, there is a high probability that the card/module could be damaged by ESD.



#### IMPORTANT

*At new site installations*, to facilitate the complete test of each SCCP shelf (if the shelf is not already fully populated with BBX2 boards), move BBX2 boards from shelves currently not under test and install them into the empty BBX2 slots of the shelf currently being tested to insure that all BBX2 TX paths are tested.

- This procedure can be bypassed on operational sites that are due for periodic optimization.
- Prior to testing, view the CDF file to verify the correct BBX2 slots are equipped. Edit the file as required to include BBX2 slots not currently equipped (per Systems Engineering documentation).

## BLO Calibration Data File

During the calibration process, the LMF creates a calibration (BLO) data file. After calibration has been completed, this offset data must be downloaded to the BBX2s using the Download BLO function. An explanation of the file is shown below.

### NOTE

Due to the size of the file, Motorola recommends that you print out a hard copy of a bts.cal file and refer to it for the following descriptions.

The CAL file is subdivided into sections organized on a per slot basis (a slot Block).

**Slot 1** contains the calibration data for the 12 BBX2 slots. **Slot 20** contains the calibration data for the redundant BBX2 (see Table 3-31). Each BBX2 slot header block contains:

- A creation Date and Time – broken down into separate parameters of createMonth, createDay, createYear, createHour, and createMin.
- The number of calibration entries – fixed at 720 entries corresponding to 360 calibration points of the CAL file including the slot header and actual calibration data.
- The calibration data for a BBX2 is organized as a large flat array. The array is organized by branch, BBX2 slot, and calibration point.
  - The first breakdown of the array indicates which branch the contained calibration points are for. The array covers transmit, main receive and diversity receive offsets as follows:

**Table 3-30:** BLO BTS.cal file Array Branch Assignments

Range	Assignment
C[1]–C[120]	Transmit
C[121]–C[240]	Receive
C[241]–C[360]	Diversity Receive

- The second breakdown of the array is per sector. Three sectors are allowed.

**Table 3-31: BTS.cal File Array (Per Sector)**

BBX2	Sectorization	TX	RX	RX Diversity
<b>Slot[1] (Primary BBX2s 1 through 12)</b>				
1 (Omni)	3-Sector, 1st Carrier	C[1]–C[20]	C[121]–C[140]	C[241]–C[260]
2		C[21]–C[40]	C[141]–C[160]	C[261]–C[280]
3		C[41]–C[60]	C[161]–C[180]	C[281]–C[300]
4	3-Sector, 2nd Carrier	C[61]–C[80]	C[181]–C[200]	C[301]–C[320]
5		C[81]–C[100]	C[201]–C[220]	C[321]–C[340]
6		C[101]–C[120]	C[221]–C[240]	C[341]–C[360]
<b>Slot[20] (Redundant BBX2–R1)</b>				
1 (Omni)	3-Sector, 1st Carrier	C[1]–C[20]	C[121]–C[140]	C[241]–C[260]
2		C[21]–C[40]	C[141]–C[160]	C[261]–C[280]
3		C[41]–C[60]	C[161]–C[180]	C[281]–C[300]
4	3-Sector, 2nd Carrier	C[61]–C[80]	C[181]–C[200]	C[301]–C[320]
5		C[81]–C[100]	C[201]–C[220]	C[321]–C[340]
6		C[101]–C[120]	C[221]–C[240]	C[341]–C[360]

- Refer to the hard copy of the file. As you can see, 10 calibration points per sector are supported for each branch. Two entries are required for each calibration point.
- The first value (all odd entries) refer to the CDMA channel (frequency) the BLO is measured at. The second value (all even entries) is the power set level. The valid range for PwrLvlAdj is from 2500 to 27500 (2500 corresponds to –125 dBm and 27500 corresponds to +125 dBm).
- The 20 calibration entries for each slot/branch combination must be stored in order of increasing frequency. If less than 10 points (frequencies) are calibrated, the largest frequency that is calibrated is repeated to fill out the 10 points.

Example:

$C[1]=384,$       *odd cal entry*      = 1 “calibration point”

$C[2]=19102,$       *even cal entry*

$C[3]=777,$

$C[4]=19086,$

⋮

⋮

$C[19]=777,$

$C[20]=19086,$  (since only two cal points were calibrated this would be repeated for the next 8 points)

- When the BBX2 is loaded with BLO data, the cal file data for the BBX2 is downloaded to the device in the order it is stored in the CAL

file. TxCal data is sent first, C[1] – C[60]. BBX2 slot 1's 10 calibration points are sent (C[1] – C[20]), followed by BBX2 slot 2's 10 calibration points (C[21] – C[40]), etc. The RxCal data is sent next, followed by the RxDCal data.

- Temperature compensation data is also stored in the cal file for each slot.

### Test Equipment Setup: RF Path Calibration

Follow the steps outlined in Table 3-32 to set up test equipment.

Table 3-32: Test Equipment Setup (RF Path Calibration)	
Step	Action
	<b>NOTE</b> Verify the GPIB is properly connected and turned on.
	<b>! CAUTION</b> To prevent damage to the test equipment, all transmit (TX) test connections must be via the 30 dB directional coupler for 800 MHz or via a 30 dB coupler with a 20 dB in-line attenuator for 1900 MHz.
1	Connect the LMF computer terminal to the BTS LAN A connector on the BTS (if you have not already done so). Refer to the procedure in NO TAG. <ul style="list-style-type: none"> <li>• If required, calibrate the test equipment per the procedure in Table 3-24.</li> <li>• Connect the test equipment as shown in Figure 3-14 and Figure 3-15.</li> </ul>

### Transmit (TX) Path Calibration

The assigned channel frequency and power level (as measured at the top of the frame) for transmit calibration is derived from the site CDF file. For each BBX2, the channel frequency is specified in the `ChannelList` CDF file parameter and the power is specified in the `SIFPilotPwr` CDF file parameter for the sector associated with the BBX2 (located under the `ParentSECTOR` field of the `ParentCARRIER` CDF file parameter).

The calibration procedure attempts to adjust the power to within  $\pm 0.5$  dB of the desired power. The calibration will pass if the error is less than  $\pm 1.5$  dB.

The TX Bay Level Offset at sites WITHOUT the directional coupler option, is approximately 42.0 dB  $\pm 3.0$  dB.

- At sites WITHOUT RFDS option, BLO is approximately 42.0 dB  $\pm 4.0$  dB. A typical example would be TX output power measured at BTS (36.0 dBm) minus the BBX2 TX output level (approximately -6.0 dBm) would equate to 42 dB BLO.

The TX Bay Level Offset at sites WITH the directional coupler option, is approximately 41.4 dB  $\pm 3.0$  dB. TX BLO = Frame Power Output minus BBX2 output level.

- Example: TX output power measured at RFDS TX coupler (39.4 dBm) minus the BBX TX output level (approximately

–2.0 dBm) and RFDS directional coupler/cable (approximately –0.6 dBm) would equate to 41.4 dB BLO.

The LMF **Tests** menu list items, **TX Calibration** and **All Cal/Audit**, perform the TX BLO Calibration test for a XCVR(s). The **All Cal/Audit** menu item performs TX calibration, downloads BLO, and performs TX audit if the TX calibration passes. All measurements are made through the appropriate TX output connector using the calibrated TX cable setup.

### Prerequisites

Before running this test, ensure that the following have been done:

- CSM–1, GLIs, MCCs, and BBX2s have correct code load and data load.
- Primary CSM and MGLI are INS.
- All BBX2s are OOS\_RAM.
- Test equipment and test cables are calibrated and connected for TX BLO calibration.
- LMF is logged into the BTS.

Connect the test equipment as shown in Figure 3-14 and Figure 3-15 and follow the procedure in Table 3-33 to perform the TX calibration test.



#### WARNING

*Before* installing any test equipment directly to any **TX OUT** connector, *first verify there are no CDMA BBX2 channels keyed*. Failure to do so can result in serious personal injury and/or equipment damage.



#### IMPORTANT

Verify all BBX2 boards removed and repositioned have been returned to their assigned shelves/slots. Any BBX2 boards moved since they were downloaded will have to be downloaded again.

Table 3-33: BTS TX Path Calibration	
Step	Action
1	Select the BBX2(s) to be calibrated.
2	From the <b>Tests</b> menu, select <b>TX Calibration</b> or <b>All Cal/Audit</b> .
3	Select the appropriate carrier(s) displayed in the <b>Channels/Carrier</b> pick list. Press and hold the <Shift> or <Ctrl> key to select multiple items.
4	Type the appropriate channel number in the <b>Carrier n Channels</b> box.
5	Click on <b>OK</b> .
6	Follow the cable connection directions as they are displayed. The test results will be displayed in the status report window.
7	Click on <b>Save Results</b> or <b>Dismiss</b> to close the status report window.

### Exception Handling

In the event of a failure, the calibration procedure displays a **FAIL** message in the status report window and provides information in the **Description** field.

Recheck the test setup and connection and re-run the test. If the tests fail again, note specifics about the failure, and refer to Chapter 6, *Troubleshooting*.

### Download BLO Procedure

After a successful TX path calibration, download the bay level offset (BLO) calibration file data to the BBX2s. BLO data is extracted from the CAL file for the Base Transceiver Subsystem (BTS) and downloaded to the selected BBX2 devices.

#### NOTE

If a successful **All Cal/Audit** was completed, this procedure does not need to be performed, as BLO is downloaded as part of the **All Cal/Audit**.

### Prerequisites

Ensure the following prerequisites have been met before proceeding.

- BBXs being downloaded are OOS-RAM (yellow).
- TX calibration successfully completed

Follow the steps in Table 3-34 to download the BLO data to the BBX2s.



---

## Bay Level Offset Calibration – continued

**Table 3-34:** Download BLO

Step	Action
1	Select the BBX2(s) to be downloaded.
2	From the <b>Device</b> menu, select <b>Download BLO</b> . A status report window displays the result of the download. <b>NOTE</b> Selected device(s) do not change color when BLO is downloaded.
3	Click <b>OK</b> to close the status report window.

### Calibration Audit Introduction

The BLO calibration audit procedure confirms the successful generation and storage of the BLO calibrations. The calibration audit procedure measures the path gain or loss of every BBX2 transmit path at the site. In this test, actual system tolerances are used to determine the success or failure of a test. The same external test equipment set up is used.

3



#### IMPORTANT

RF path verification, BLO calibration, and BLO data download to BBX2s must have been successfully completed prior to performing the calibration audit.

### Transmit (TX) Path Audit

Perform the calibration audit of the TX paths of all equipped BBX2 slots, per the steps in Table 3-35.



#### WARNING

*Before* installing any test equipment directly to any **TX OUT** connector, *first verify there are no CDMA BBX2 channels keyed*. Failure to do so can result in serious personal injury and/or equipment damage.

#### NOTE

If a successful **All Cal/Audit** was completed, this procedure does not need to be performed, as BLO is downloaded as part of the **All Cal/Audit**.

### TX Audit Test

The **Tests** menu item, **TX Audit**, performs the TX BLO Audit test for a BBX2(s). All measurements are made through the appropriate TX output connector using the calibrated TX cable setup.

#### Prerequisites

Before running this test, the following should be done:

- CSM-1, GLI2s, BBX2s have correct code load.
- Primary CSM and MGLI2 are INS.
- All BBX2s are OOS\_RAM.
- Test equipment and test cables are calibrated and connected for TX BLO calibration.
- LMF is logged into the BTS.

Connect the test equipment as shown in Figure 3-14 and Figure 3-15 and follow the procedure in Table 3-35 to perform the BTS TX Path Audit test.

<b>Step</b>	<b>Action</b>
1	Select the BBX2(s) to be audited. From the <b>Tests</b> menu, select <b>TX Audit</b> .
2	Select the appropriate carrier(s) displayed in the <b>Channels/Carrier</b> pick list. Press and hold the <Shift> or <Ctrl> key to select multiple items.
3	Type the appropriate channel number in the <b>Carrier n Channels</b> box.
4	Click on <b>OK</b> .
5	Follow the cable connection directions as they are displayed. A status report window displays the test results.
6	Click on <b>Save Results</b> or <b>Dismiss</b> to close the status report window.

#### Exception Handling

In the event of a failure, the calibration procedure displays a **FAIL** message in the status report window and provides information in the **Description** field.

Recheck the test setup and connection and re-run the test. If the tests fail again, note specifics about the failure, and refer to Chapter 6, *Troubleshooting*.

All Cal/Audit Test

The **Tests** menu item, **All Cal/Audit**, performs the TX BLO Calibration and Audit test for a XCVR(s). All measurements are made through the appropriate TX output connector using the calibrated TX cable setup.

**NOTE**

If the TX calibration portion of the test passed, the BLO data will automatically be downloaded to the BBX2(s) before the audit portion of the test is run.

**Prerequisites**

Before running this test, the following should be done:

- CSM-1, GLI2s, BBX2s have correct code and data load.
- Primary CSM and MGLI2 are INS.
- All BBXs are OOS\_RAM.
- Test equipment and test cables are calibrated and connected for TX BLO calibration.
- LMF is logged into the BTS.

Follow the procedures in Table 3-36 to perform the All Cal/Audit test.



**WARNING**

*Before* installing any test equipment directly to any **TX OUT** connector, *first verify there are no CDMA BBX2 channels keyed*. Failure to do so can result in serious personal injury and/or equipment damage.

**Table 3-36: All Cal/Audit Test**

Step	Action
1	Select the BBX2(s) to be tested. From the <b>Tests</b> menu, select <b>All Cal/Audit</b> .
2	Select the appropriate carrier(s) displayed in the <b>Channels/Carrier</b> pick list. Press and hold the <Shift> or <Ctrl> key to select multiple items.
3	Type the appropriate channel number in the <b>Carrier n Channels</b> box.
4	Click on <b>OK</b> .
5	Follow the cable connection directions as they are displayed. A status report window displays the test results.
6	Click on <b>Save Results</b> or <b>Dismiss</b> to close the status report window.

**Create CAL File**

The Create Cal File function gets the BLO data from BBXs and creates/updates the CAL file for the BTS. If a CAL file does not exist a new one is created. If a CAL file already exists it is updated. After a BTS has been fully optimized a copy of the CAL file must exist so it can be transferred to the CBSC. If TX calibration has been successfully performed for all BBXs and BLO data has been downloaded, a CAL file will exist. Note the following:

- The Create Cal File function only applies to selected (highlighted) BBXs.



**WARNING**

Editing the CAL file is not encouraged as this action can cause interface problems between the BTS and the LMF. To manually edit the CAL file you must first logout of the BTS. If you manually edit the CAL file and then use the Create Cal File function the edited information will be lost.

**Prerequisites**

Before running this test, the following should be done:

- LMF is logged in to the BTS
- BBX2s are OOS\_RAM with BLO downloaded

**Table 3-37: Create CAL File**

Step	Action
1	Select the applicable BBX2s. The CAL file will only be updated for the selected BBX2s.
2	Click on the <b>Device</b> menu.
3	Click on the <b>Create Cal File</b> menu item. The status report window is displays the results of the action.
4	Click <b>OK</b> .

### RFDS Description

The optional RFDS is a Field Replaceable Unit (FRU) used to perform RF tests of the site from the CBSC or from the LMF. The RFDS contains the following elements:

- Antenna Select Unit (ASU)
- FWT Interface Card (FWTIC)
- Subscriber Unit Assembly (SUA)

For complete information regarding the RFDS, refer to the CDMA RFDS Hardware Installation manual (Motorola part no. 6864113A93) CDMA RFDS User's Guide (Motorola part no. 6864113A37), and the CDMA LMF Operator's Guide (Motorola part no. 6864113A21).

### RFDS Parameter Settings

The `bts-#.cdf` file includes RFDS parameter settings that must match the installed RFDS equipment. The paragraphs below describe the editable parameters and their defaults. Table 3-38 explains how to edit the parameter settings.

- **RfdsEquip** – valid inputs are 0 through 2.
  - 0 = (default) RFDS is not equipped
  - 1 = Non-Cobra/Patzer box RFDS
  - 2 = Cobra RFDS
- **TsuEquip** – valid inputs are 0 or 1
  - 0 = (default) TSU not equipped
  - 1 = TSU is equipped in the system
- **MC1...4** – valid inputs are 0 or 1
  - 0 = (default) Not equipped
  - 1 = Multicouplers equipped in RFDS system  
(9600 system RFDS only)
- **Asu1/2Equip** – valid inputs are 0 or 1
  - 0 = (default) Not equipped
  - 1 = Equipped
- **TestOrigDN** – valid inputs are "" (default) or a numerical string up to 15 characters. (This is the phone number the RFDS dials when originating a call. A dummy number needs to be set up by the switch, and is to be used in this field.)

#### NOTE

Any text editor may be used to open the `bts-#.cdf` file to verify, view, or modify data.

**Table 3-38: RFDS Parameter Settings**

Step	Action
	<p><b>* IMPORTANT</b> Log out of the BTS prior to performing this procedure.</p>
1	<p>Using a text editor, verify the following fields are set correctly in the <code>bts-#.cdf</code> file (1 = GLI based RFDS; 2 = Cobra RFDS).</p> <p><b>EXAMPLE:</b></p> <pre>RfdsEquip = 2 TsuEquip = 1 MC1Equip = 0 MC2Equip = 0 MC3Equip = 0 MC4Equip = 0 Asu1Equip = 1 Asu2Equip = 0 (1 if system is non-duplexed) TestOrigDN = '123456789'</pre> <p><b>NOTE</b> The above is an example of the <code>bts-#.cdf</code> file that should have been generated by the OMC and copied to the LMF. These fields will have been set by the OMC if the RFDSPARM database is modified for the RFDS.</p>
2	<p>Save and/or quit the editor. If any changes were made to these fields data will need to be downloaded to the GLI2 (see Step 3, otherwise proceed to Step 4).</p>
3	<p>To download to the GLI2, click on the <b>Device</b> menu and select the <b>Download Data</b> menu item (<i>selected devices do not change color when data is downloaded</i>). A status report window is displayed showing status of the download. Click <i>OK</i> to close the status report window.</p> <p><b>! CAUTION</b> After downloading data to the GLI2 the RFDS LED will slowly begin flashing red and green for approximately 2–3 minutes. <b>DO NOT</b> attempt to perform any functions with the RFDS until the LED remains green.</p>
4	<p>Status the RFDS TSU. A status report is displayed showing the software version number for the TSIC and SUA.</p> <p><b>* IMPORTANT</b> If the LMF yields an error message, check the following:</p> <ul style="list-style-type: none"> <li>• Ensure AMR cable is correctly connected from the BTS to the RFDS.</li> <li>• Verify RFDS has power.</li> <li>• Verify RFDS status LED is green.</li> <li>• Verify fields in the <code>bts-#.cdf</code> file are correct (see Step 1).</li> <li>• Status the GLI2 and ensure the device is communicating (via Ethernet) with the LMF, and the device is in the proper state (INS).</li> </ul>

RFDS TSU NAM Programming

The NAM (number assignment module) information needs to be programmed into the TSU before it can receive and process test calls, or be used for any type of RFDS test. The RFDS TSU NAM must be programmed with the appropriate system parameters and phone number during hardware installation. The TSU phone and TSU MSI must be recorded for each BTS used for OMC-R RFDS software configuration.

**NOTE**

The user will only need to program the NAM for the initial install of the RFDS.

**Explanation of Parameters used when Programming the TSU NAM**

Table 3-39 defines the parameters used when editing the tsu.nam file.

<b>Table 3-39: Definition of Parameters</b>	
Access Overload Code Slot Index System ID Network ID	These parameters are obtained from the switch.
Primary Channel A Primary Channel B Secondary Channel A Secondary Channel B	These parameters are the channels which are to be used in operation of the system.
Lock Code Security Code Service Level Station Class Mark	Do <b>NOT</b> change.
IMSI MCC IMSI 11 12	These fields are obtained at the OMC using the following command: <b>OMC000&gt;disp bts-# imsi</b> If the fields are blank, replace the IMSI fields in the NAM file to 0, otherwise use the values displayed by the OMC.
MIN Phone Number	These fields are the phone number assigned to the mobile. The ESN and MIN must be entered into the switch as well. <b>NOTE:</b> This field is different from the TODN field in the <code>bts-#.cdf</code> file. The MIN is the phone number of the RFDS subscriber, and the TODN is the number the subscriber calls.





## RFDS Setup and Calibration – continued

### Valid NAM Ranges

Table 3-40 provides the valid NAM field ranges. If any of the fields are missing or out-of-range, the RFDS will error out.

**Table 3-40:** Valid NAM Field Ranges

NAM Field Name	Valid Range	
	Minimum	Maximum
Access Overload Code	0	15
Slot Index	0	7
System ID	0	32767
Network ID	0	32767
Primary Channel A	25	1175
Primary Channel B	25	1175
Secondary Channel A	25	1175
Secondary Channel B	25	1175
Lock Code	0	999
Security Code	0	999999
Service Level	0	7
Station Class Mark	0	255
IMSI 11 12	0	99
IMSI MCC	0	999
MIN Phone Number	N/A	N/A

### Set Antenna Map Data

The antenna map data must be entered manually if an RFDS is installed. Antenna map data does not have to be entered if an RFDS is not installed. The antenna map data is only used for RFDS tests and is required if a RFDS is installed.

#### Prerequisite

- Logged into the BTS

**Table 3-41: Set Antenna Map Data**

Step	Action
1	Click on the <b>Util</b> menu.
2	Select <b>Edit &gt;Antenna Map &gt;TX or RX</b> . A data entry pop-up window will appear.
3	Enter/edit values as required for each carrier. <b>NOTE</b> Refer to the <b>Util &gt;Edit-antenna map</b> LMF help screen for antenna map examples.
4	Click on the <b>Save</b> button to save displayed values.
5	Click on the <b>Dismiss</b> button to exit the window. Values that were entered/changed after the <b>Save</b> button was used will not be saved. <b>NOTE</b> Entered values will be used by the LMF as soon as they are saved. You do not have to logout and login.

## Set RFDS Configuration Data

If an RFDS is installed the RFDS configuration data must be manually entered.

### Prerequisite

- Logged into the BTS



### IMPORTANT

The entered **antenna#** index numbers must correspond to the **antenna#** index numbers used in the antenna maps.

**Table 3-42: Set RFDS Configuration Data**

Step	Action
1	Click on the <b>Util</b> menu.
2	Select <b>Edit &gt;RFDS Configuration &gt;TX</b> or <b>RX</b> . A data entry pop-up window will appear.
3	Click on the Add Row button to add a new antenna number. Then click in the other columns and enter the desired data.
4	To edit existing values click in the data box to be changed and change the value. <b>NOTE</b> Refer to the <b>Util &gt;Edit-RFDS Configuration</b> LMF help screen for RFDS configuration data examples.
5	To delete a row, click on the row and then click on the <b>Delete Row</b> button.
6	Click on the <b>Save</b> button to save displayed values.
7	Click on the <b>Dismiss</b> button to exit the window. Values that were entered/changed after the <b>Save</b> button was used will not be saved. <b>NOTE</b> Entered values will be used by the LMF as soon as they are saved. You do not have to logout and login.

## RFDS Calibration

3

The RFDS Calibration option is used to calibrate the RFDS TX and RX paths. For a TX antenna path calibration the BTS XCVR is keyed at a pre-determined power level and the BTS power output level is measured by the RFDS. The power level is then measured at the TX antenna directional coupler by the power measuring test equipment item being used (power meter or analyzer). The difference (offset) between the power level at the RFDS and the power level at the TX antenna directional coupler is used as the TX RFDS calibration offset value.

For an RX antenna path calibration the RFDS is keyed at a pre-determined power level and the power input level is measured by the BTS XCVR. A CDMA signal at the same power level measured by the BTS XCVR is then injected at the RX antenna directional coupler by the CDMA communications analyzer. The difference (offset) between the RFDS keyed power level and power level measured at the BTS XCVR is the RFDS RX calibration offset value.

The TX and RX RFDS calibration offset values are written to the CAL file.

For each RFDS TSIC, the channel frequency is determined at the lower third and upper third of the appropriate band using the frequencies listed in Table 3-43.

System	Channel Calibration Points
800 MHz (A and B)	341 and 682
1.9 GHz	408 and 791



### WARNING

*Before* installing any test equipment directly to any **TX OUT** connector, *verify that there are no CDMA BBX channels keyed*. Failure to do so can result in serious personal injury and/or equipment damage.

### Prerequisites

- BBX2s are is INS\_TEST
- Cable calibration has been performed
- TX calibration has been performed and BLO has been downloaded for the BTS
- Test equipment has been connected correctly for a TX calibration
- Test equipment has been selected and calibrated

**Table 3-44: RFDS Calibration**

Step	Action
1	Select the RFDS tab.
2	Click on the <b>RFDS</b> menu.
3	Click on the <b>RFDS Calibration</b> menu item
4	Select the appropriate direction (TX/RX) in the <b>Direction</b> pick list
5	Enter the appropriate channel number(s) in the <b>Channels</b> box. Separate the channel numbers with a comma or a dash if more than one channel number is entered (e.g., 247,585,742 or 385–395 for through).
6	Select the appropriate carrier(s) in the <b>Carriers</b> pick list (use the <b>Shift</b> or <b>Ctrl</b> key to select multiple carriers).
7	Select the appropriate <b>RX branch</b> (Both, Main, or Diversity) in the RX Branch pick list.
8	Select the appropriate baud rate (1=9600, 2=14400) in the <b>Rate Set</b> pick list.
9	Click on the <b>OK</b> button. A status report window is displayed, followed by a <b>Directions</b> pop-up window.
10	Follow the cable connection directions as they are displayed. Test results are displayed in the status report window.
11	Click on the <b>OK</b> button to close the status report window.



### Program TSU NAM

Follow the procedure in Table 3-45 to program the TSU NAM. The NAM must be programmed before it can receive and process test calls, or be used for any type of RFDS test.

#### Prerequisites

- MGLI is INS.
- TSU is powered up and has a code load.

**Table 3-45:** Program NAM Procedure

Step	Action
1	Select the RFDS tab.
2	Select the TSU tab.
3	Click on the <b>TSU</b> menu.
4	Click on the <b>Program TSU NAM</b> menu item.
5	Enter the appropriate information in the boxes (see Table 3-39 and Table 3-40) .
6	Click on the <b>OK</b> button to display the status report.
7	Click on the <b>OK</b> button to close the status report window.

---

## Alarms Testing

### Alarm Verification

The alarms testing should be performed at a convenient point in the optimization/ATP process, since the LMF is necessary to ensure that the SC4812ETL is generating the appropriate alarms.

The SC 4812ETL is capable of concurrently monitoring 10 customer defined input signals and four customer defined outputs, which interface to the 50-pin punchblock. All alarms are defaulted to “Not Equipped” during ATP testing. Testing of these inputs is achieved by triggering the alarms and monitoring the LMF for state-transition messages from the active MGLI2.

All customer alarms are routed through the 50 pair punchblock located in the I/O compartment at the back of the frame. Testing is best accomplished by using a specialized connector that interfaces to the 50-pair punchblock. This connector is wired so that customer return 1 (2 for the B side) is connected to every input, CDI 0 through CDI 17.

### Alarm Reporting Display

The Alarm Monitor window can be displayed to list alarms that occur after the window is displayed. To access the Alarm Monitor window, select **Util>Alarm Monitor**.

The following buttons are included.

- The **Options** button allows for a severity level (**Warning**, **Minor**, and **Major**) selection. The default is all levels. To change the level of alarms reported click on the **Options** button and highlight the desired alarm level(s). To select multiple levels press the Ctrl key (for individual selections) or Shift key (for a range of selections) while clicking on the desired levels.
- The **Pause** button can be used to pause/stop the display of alarms. When the **Pause** button is clicked the name of the button changes to **Continue**. When the **Continue** button is click the display of alarms will continue. Alarms that occur between the time the **Pause** button is clicked and the **Continue** button is clicked will not be displayed.
- The **Clear** button can be used to clear the Alarm Monitor display. New alarms that occur after the **Clear** button is clicked will be displayed.
- The **Dismiss** button is used to dismiss/close the Alarm Monitor display.

## Alarms Testing – continued

### Heat Exchanger Alarm Test

Table 3-46 gives instructions on testing the Heat Exchanger alarm.

Table 3-46: Heat Exchanger Alarm	
Step	Action
1	Turn circuit breaker “B” of the Heat Exchanger circuit breakers OFF. This will generate a Heat Exchanger alarm, ensure that the LMF reports the correct alarm condition.
2	Alarm condition will be reported as <b>BTS Relay #25</b> – “Heat Exchanger Alarm” makes contact.
3	Turn the circuit breaker “B” ON. Ensure that the alarm condition is now removed. <b>NOTE</b> The Heat Exchanger will go through the Start Up sequence.

### Door Alarm

Table 3-47 gives instructions on testing the door alarms.

Table 3-47: Door Alarm	
Step	Action
1	Close all doors on the cabinet. Ensure that no alarms are reported on the LMF.
2	Individually open and then close each power supply cabinet door. Ensure that the LMF reports an alarm when each door is opened.
3	Alarm condition will be reported as <b>BTS Relay #27</b> “Door Alarm” makes contact.

### AC Fail Alarm

Table 3-48 gives instructions on testing the AC Fail Alarm.

Table 3-48: AC Fail Alarm	
Step	Action
1	<b>NOTE</b> The batteries should have a stable charge before performing this test. Turn the Main AC breaker on the ACLC OFF. The LMF should report an alarm on an AC Fail (Rectifier Fail, Minor Alarm & Major Alarm) condition.
2	Alarm condition will be reported as <b>BTS Relay #23, BTS # 21, BTS # 24 and BTS Relay # 29 “AC Fail Alarm”</b> makes contact respectively.
3	Turn the Main AC breaker on the ACLC ON. The AC Fail alarm should clear.



## Alarms Testing – continued

### Minor Alarm

Table 3-49 gives instructions on testing minor alarm.

Table 3-49: Minor Alarm	
Step	Action
1	Turn the Temperature Compensation Panel (TCP) power switch OFF. This will generate a minor alarm. Verify that the minor alarm LED (amber) is illuminated on the Meter Alarm Panel and the LMF reports this minor alarm.
2	Alarm condition will be reported as <b>BTS Relay #24</b> “Minor Alarm” makes contact.
3	Turn the TCP power switch ON. The alarm condition should clear.

3

### Rectifier Alarms

The following series of tests are for single rectifier modules in a multiple rectifier system. The systems include a three rectifier and a six rectifier system.

#### Single Rectifier Failure (Three Rectifier System)

Table 3-50 gives instructions on testing single rectifier failure or minor alarm in a **three (3) rectifier system**.

Table 3-50: Single Rectifier Fail or Minor Alarm	
Step	Action
1	Remove a single rectifier module and place it into the unused rectifier shelf #2.
2	Turn the AC breaker OFF, for this 2nd shelf.
3	Verify that a rectifier fail alarm is generated. The single rectifier module will illuminate two (2) RED fail LED (DC and Power), and the Meter Alarm Panel and LMF will also indicate a minor alarm and rectifier fail status. The RECTIFIER FAIL LED will illuminate.
4	Check that the LMF reports both of these alarm conditions. <b>NOTE</b> Alarm conditions reported as <b>BTS #24 and BTS #21</b> , contacts respectively.
5	Turn the AC breaker for the 2nd shelf ON and verify that Rectifier Fail and minor alarm conditions clear on the Meter Alarm Panel and LMF.

### Multiple Rectifier Failure

Table 3-51 gives instructions on testing multiple rectifier failure or major alarm in a **three (3) rectifier system**.

## Alarms Testing – continued

**Table 3-51: Multiple Rectifier Failure or Major Alarm**

Step	Action
1	With the rectifier module still in the unused shelf position from Table 3-50 test procedures, turn the AC breaker for the 1st shelf OFF.
2	Verify that a rectifier alarm is generated. Each of the two rectifier modules will illuminate two (2) RED fail LED (DC and Power), and the Meter Alarm Panel and LMF will indicate a major alarm (Rectifier Fail and Major Alarm). The RECTIFIER FAIL LED will illuminate.
3	Verify that the LMF reports both alarm conditions. <b>(BTS #29, BTS #21, and BTS #24)</b>
4	Turn the AC breaker for the 1st shelf ON. Verify that all alarms have cleared.
5	Return the rectifier module to its original location. This completes the multiple rectifier alarm test.

### Single Rectifier Failure (Six Rectifier System)

Table 3-52 gives instructions on testing single rectifier failure or minor alarm in a **six (6) rectifier system**.

**Table 3-52: Single Rectifier Fail or Minor Alarm**

Step	Action
1	Remove two(2) rectifier modules from shelf #2.
2	Turn the AC breaker OFF, for shelf #2.
3	Verify that a rectifier fail alarm is generated. The single rectifier module will illuminate two (2) RED fail LED (DC and Power), and the Meter Alarm Panel and LMF will also indicate a minor alarm and rectifier fail status. The RECTIFIER FAIL LED will illuminate.
4	Check that the LMF reports both of these alarm conditions. <b>(BTS #24 and BTS #21)</b>
5	Turn the AC breaker for this shelf ON and verify that Rectifier Fail and Minor Alarm conditions have cleared.

### Multiple Rectifier Failure (Six Rectifier System)

Table 3-53 gives instructions on testing multiple rectifier failure or major alarm in a **six (6) rectifier system**.

**Table 3-53: Multiple Rectifier Failure or Major Alarm**

Step	Action
1	Replace one rectifier module previously removed and turn the AC breaker for this shelf, OFF.
2	Verify that a rectifier alarm is generated. Each of the two rectifier modules will illuminate a RED fail LED, and the Meter Alarm Panel will indicate a major alarm (Rectifier Fail, Major and Minor Alarm). The RECTIFIER FAIL LED will illuminate.

. . . continued on next page

Table 3-53: Multiple Rectifier Failure or Major Alarm	
Step	Action
3	Verify that the LMF reports both alarm conditions. (BTS #29)
4	Turn the AC breaker for this shelf ON. Verify that all alarms have cleared.
5	Return all rectifier module to their original location. This completes the rectifier alarm tests.

3

**Battery Over Temperature Alarm (Optional)**



**CAUTION**

Use special care to avoid damaging insulation on cables, or damaging battery cases when using a power heat gun.





Table 3-54 gives instructions on testing the battery over temperature alarm system.

Table 3-54: Battery Over Temperature Alarm	
Step	Action
1	Use a low powered heat gun and gently heat the battery over temperature sensor (see location in Figure 3-20). Do Not hold the hot air gun closer than three (3) inches to the sensor. This will avoid burning the cable insulation.
2	When the sensor is heated to approximately 50° C, a battery Over Temperature alarm is generated. <b>NOTE</b> An audible click will sound as K1 contact engage and K2 contacts disengage.
3	Visually inspect the K1 and K2 relays to verify state changes. The LMF should be displaying correct alarms. (BTS #22)
4	Verify that the CHARGE DISABLE LED (amber) on the Meter Alarm Panel and the BATTERY MAIN LED (green) are both illuminated.
5	Switch the hot air gun to cool. Cool the sensor until the K1 and K2 contact return to normal position (K1 open and K2 closed). Use the LMF verify that all alarms have cleared.

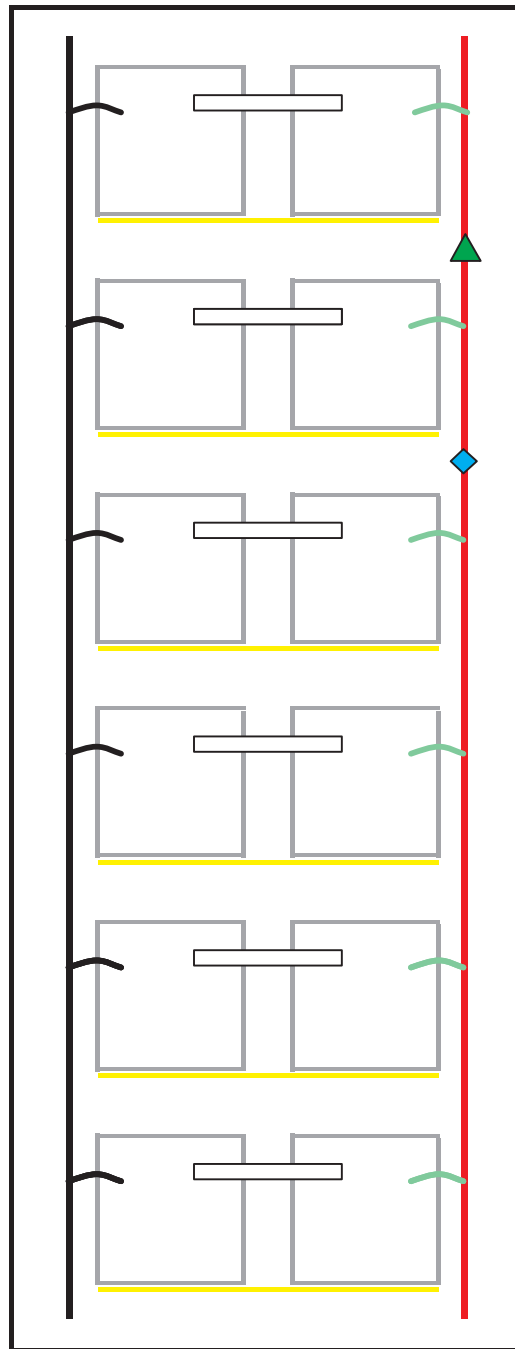
Figure 3-20: Battery Overtemperature Sensor

3



-  Buss Bar
-  6 AWG Cables
-  Battery Overtemp Sensor
-  Negative Temperature Compensation Sensor

SC4812ETL0014-1

**Rectifier Over Temperature Alarm**

**NOTE**

This is the J8 on the rear of the Meter Alarm Panel itself, this is not connector J8 on the connector bulkhead at the rear of the cabinet.

Table 3-55 gives instructions on testing the battery over temperature alarm system.

**Table 3-55: Rectifier Over Temperature Alarm**

Step	Action
1	Remove the J8 link on the rear of the Meter Alarm Panel (see Figure 3-21 for J8 location). <b>NOTE</b> This is the J8 on the rear of the Meter Alarm Panel itself, this is not connector J8 on the connector bulkhead at the rear of the cabinet.
2	Verify that RECTIFIER OVERTEMP LED (red) is illuminated. Contacts on K1 and K2 change states (K1 now closed and K2 open).
3	Verify that the LMF has reported an alarm condition. <b>(BTS #26)</b>
4	Reinstall J8 connector and verify that all alarm conditions have cleared. K1 and K2 should now be in their normal states (K1 open and K2 closed).
5	This completes the system tests of the SC 4812ETL cabinet.

# Alarms Testing – continued

**Figure 3-21:** Location of Connector J8 on the Meter Alarm Panel

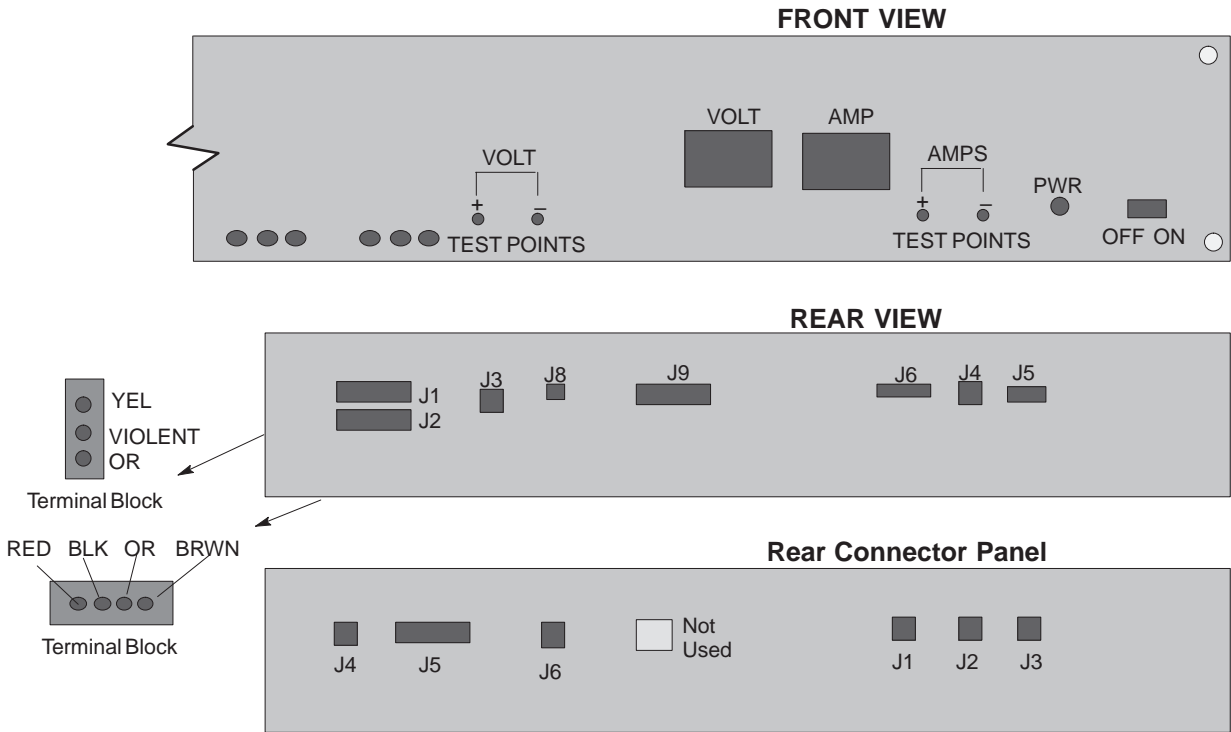

## Before Leaving the site

Table 3-56 gives instructions on what to check before leaving the site.

Step	Action
1	Verify that ALL battery circuit breakers (for occupied shelves) are CLOSED (pushed in).
2	Verify that the Heat Exchanger is running.
3	Verify that the Meter Alarm Panel and TCP modules are switched ON.
4	Verify that the Battery Test Switch on the Meter Alarm Panel is in the OFF position.
5	Verify that no alarm conditions are being reported (with all doors closed).

# Chapter 4: Automated Acceptance Test Procedure (ATP)

## Table of Contents

---

Automated Acceptance Test Procedure – Introduction .....	4-1
Introduction .....	4-1
Prerequisites .....	4-2
TX/RX OUT Connections .....	4-2
Acceptance Tests – Test Set Up .....	4-3
Required Test Equipment .....	4-3
Acceptance Test Equipment Set Up .....	4-3
Abbreviated (All-inclusive) Acceptance Tests .....	4-4
All-inclusive Tests .....	4-4
All TX/RX ATP Test .....	4-5
All TX ATP Test .....	4-5
All RX ATP Test .....	4-6
Individual Acceptance Tests–Introduction .....	4-7
Individual Acceptance Tests .....	4-7
Individual Tests .....	4-7
TX Spectral Purity Transmit Mask Acceptance Test .....	4-9
Background .....	4-9
Spectral Purity TX Mask Acceptance Test .....	4-10
TX Waveform Quality (Rho) Acceptance Test .....	4-12
Background .....	4-12
Waveform Quality (Rho) Acceptance Test .....	4-12
TX Pilot Time Offset Acceptance Test .....	4-13
Background .....	4-13
Pilot Time Offset Acceptance Test .....	4-13
TX Code Domain Power/Noise Floor Acceptance Test .....	4-15
Background .....	4-15
Code Domain Power/Noise Floor Test .....	4-15
RX FER Acceptance Test .....	4-18
Background .....	4-18
FER Acceptance Test .....	4-19
Generating an ATP Report .....	4-20
Background .....	4-20
ATP Report .....	4-20





---

# Automated Acceptance Test Procedure – Introduction

## Introduction

The automated Acceptance Test Procedure (ATP) allows Cellular Field Engineers (CFEs) to run automated acceptance tests on all equipped BTS subsystem devices using the CDMA LMF *GUI* environment and supported test equipment.

The operator can choose to save the results of these tests to a report file, from which *ATP reports* are generated for later printout.

***Perform the ATP test on out-of-service sectors or sites only.*** Because all tests are controlled via the CDMA LMF computer using the GPIB interface from the CDMA LMF computer, only recommended test equipment supported by the CDMA LMF can be used.



### IMPORTANT

Before using the LMF, use an editor to view the "CAVEATS" section in the "readme.txt" file in the c:\wlmf folder for any applicable information.



### IMPORTANT

The ATP test is to be performed on out-of-service sectors *only*.

**DO NOT** substitute test equipment with other models not supported by the LMF.

### NOTE

Refer to Chapter 3 for detailed information on test set connections for calibrating equipment, cables and other test set components, if required.

The CFE selects the appropriate ATP tests to run to satisfy customer and regulatory requirements for verifying cell site performance. These tests can be run individually or as one of the following groups:

- **All TX:** TX tests verify the performance of the BTS transmit elements. These include the GLI, MCC, BBX, BDC, and BIO modules, the ELPAs and passive components including splitters, combiners, bandpass filter(s), and RF cables.
- **All RX:** RX tests verify the performance of the BTS receive elements. These include the receive preselector (for starter frames), BIO, BBX, BDC, MCC, and GLI modules and the passive components including RX filter (starter frame only), and RF cables.
- **All TX/RX:** Executes all TX and RX tests.
- **Full Optimization:** Executes the TX calibration, downloads BLO, and executes the TX audit before running all TX and RX tests.

## Prerequisites

Before attempting to run *any* ATP tests, all applicable procedures outlined in Chapter 3, Optimization/Calibration, must have been completed successfully (i.e., code load and BLO calibration).

### NOTE

You cannot substitute test equipment with other models not supported by the CDMA LMF.

Before attempting to run *any* ATP tests, ensure the following:

- BTS has been optimized and calibrated (see Chapter 3).
- LMF is logged into the BTS
- CSMs, GLI2s, BBX2s, MCCs and TSU (if the RFDS is installed) have correct code load and data load
- Primary CSM and GLI2 are INS\_ACT
- MCCs are INS\_ACT
- BBX2s are OOS-RAM
- BBX2s are calibrated and BLOs are downloaded
- Test cables are calibrated
- Test equipment is selected
- Test equipment is connected for ATP tests
- Test equipment has been warmed up 60 minutes and calibrated
- GPIB is on



### WARNING

Before the FER is run, be sure that all LPAs are turned OFF (circuit breakers pulled) or that all transmitter ports are properly terminated.

All transmit ports must be properly terminated for all ATP tests.

Failure to observe these warnings may result in bodily injury or equipment damage.

## TX/RX OUT Connections



### IMPORTANT

Many of the acceptance test procedures require taking measurements at the **TX OUT** (BTS/RFDS) connector. At sites with RFDS, all measurements are through the RFDS directional coupler **TX OUT** connector.

# Acceptance Tests – Test Set Up

## Required Test Equipment

The following test equipment is required:

- LMF
- Power meter (used with HP8921A/600 and Advantest R3465)
- Communications test set



### WARNING

*Before* installing any test equipment directly to any **TX OUT** connector, *verify that there are no CDMA channels keyed.*

At active sites, have the OMCR/CBSC place the carrier assigned to the LPAs under test OOS. Failure to do so can result in serious personal injury and/or equipment damage.

### NOTE

You must recalibrate the test equipment before using it to perform the TX Acceptance Tests.

## Acceptance Test Equipment Set Up

Follow the steps in Table 4-1 to set up test equipment for all tests.

Table 4-1: Set Up Test Equipment – TX Output Verify/Control Tests	
Step	Action
1	<i>If it has not already been done</i> , interface the LMF computer to the BTS (refer to Table 3-6 and Figure 3-9).
2	<i>If it has not already been done</i> , refer to Table 3-7 to start a <i>GUI</i> LMF session and log into the BTS.
3	<p><i>If it has not already been done</i>, refer to Figure 3-14 through Figure 3-17, as applicable for the test equipment being used, to set up for acceptance testing.</p> <p><b>* IMPORTANT</b>            CDMA LMF-based measurement commands factor in TX test cable loss between the RFM frame and test equipment. No additional attenuation can be inserted as the <i>additional losses would not be factored in.</i></p>

---

## Abbreviated (All-inclusive) Acceptance Tests

### All-inclusive Tests

The all-inclusive acceptance tests are performed from the LMF *GUI* environment. These tests execute various combinations of individual acceptance tests with a single command. This allows verification of multiple aspects of BTS performance while minimizing time needed for individual test set up and initiation.

There are three abbreviated acceptance tests which evaluate different performance aspects of the BTS. This allows the CFE to select testing to meet the specific requirements for individual maintenance and performance verification situations. The following summarizes the coverage of each abbreviated test:

- **All TX/RX.** Performs all transmit and receive ATPs on the selected MCCs and BBXs in one test.
- **All TX.** Performs complete set of transmit ATPs on the selected MCCs and BBXs. Testing is the equivalent of performing all of the following individual tests:
  - **TX Mask** Test
  - **Rho** Test
  - **Pilot Time Offset** Test
  - **Code Domain Power** Test
- **All RX.** Performs complete receive ATP on the selected MCCs and BBXs. Testing is the equivalent of performing the following:
  - **FER** Test

## Abbreviated (All-inclusive) Acceptance Tests – continued

### All TX/RX ATP Test

Follow the procedures in Table 4-2 to perform the abbreviated, all-inclusive **transmit and receive** test.

<b>Table 4-2: All TX/RX ATP Test Procedure</b>	
<b>Step</b>	<b>Action</b>
1	Set up the test equipment initially for abbreviated tests per Table 4-1.
2	Select the BBXs and MCCs to be tested.
3	From the <b>Tests</b> menu, select <b>All TX/RX</b> .
4	Select the appropriate carrier(s) (carrier-bts#-sector#-carrier#) displayed in the <b>Channels/Carrier</b> pick list.  <b>NOTE</b> To select multiple items, hold down the <b>Shift</b> or <b>Ctrl</b> key while making the selections.
5	Enter the appropriate channel number in the <b>Carrier n Channels</b> box.
6	Click <b>OK</b> . The status report window is displayed and a <b>Directions</b> pop-up is displayed.
7	Follow the cable connection directions as they are displayed. The test results are displayed in the status report window.
8	Click <b>Save Results</b> or <b>Dismiss</b> .  <b>NOTE</b> If <b>Dismiss</b> is used, the test results <b>will not</b> be saved in the test report file.

### All TX ATP Test

Follow the procedures in Table 4-3 to perform the abbreviated, all-inclusive **transmit** test.

<b>Table 4-3: All TX ATP Test Procedure</b>	
<b>Step</b>	<b>Action</b>
1	Set up the test equipment for abbreviated tests per Table 4-1.
2	Select the BBXs and MCCs to be tested.
3	From the <b>Tests</b> menu, select <b>All TX</b> .
4	Select the appropriate carrier(s) (carrier-bts#-sector#-carrier#) displayed in the <b>Channels/Carrier</b> pick list.  <b>NOTE</b> To select multiple items, hold down the <b>Shift</b> or <b>Ctrl</b> key while making the selections.
5	Enter the appropriate channel number in the <b>Carrier n Channels</b> box.
6	Click <b>OK</b> . The status report window is displayed and a <b>Directions</b> pop-up is displayed.
7	Follow the cable connection directions as they are displayed. The test results are displayed in the status report window.

... continued on next page

## Abbreviated (All-inclusive) Acceptance Tests – continued

<b>Table 4-3: All TX ATP Test Procedure</b>	
<b>Step</b>	<b>Action</b>
8	Click <b>Save Results</b> or <b>Dismiss</b> .  <b>NOTE</b> If <b>Dismiss</b> is used, the test results <b>will not</b> be saved in the test report file.

### All RX ATP Test

Follow the procedures in Table 4-4 to perform the abbreviated, all-inclusive **receive** test.

<b>Table 4-4: All RX ATP Test Procedure</b>	
<b>Step</b>	<b>Action</b>
1	Set up the test equipment for abbreviated tests per Table 4-1.
2	Select the BBXs and MCCs to be tested.
3	From the <b>Tests</b> menu, select <b>All RX</b> .
4	Select the appropriate carrier(s) (carrier-bts#-sector#-carrier#) displayed in the <b>Channels/Carrier</b> pick list.  <b>NOTE</b> To select multiple items, hold down the <b>Shift</b> or <b>Ctrl</b> key while making the selections.
5	Enter the appropriate channel number in the <b>Carrier n Channels</b> box.
6	Click <b>OK</b> . The status report window is displayed and a <b>Directions</b> pop-up is displayed.
7	Follow the cable connection directions as they are displayed. The test results are displayed in the status report window.
8	Click <b>Save Results</b> or <b>Dismiss</b> .  <b>NOTE</b> If <b>Dismiss</b> is used, the test results <b>will not</b> be saved in the test report file.

---

# Individual Acceptance Tests—Introduction

## Individual Acceptance Tests

The following individual ATP tests can be used to evaluate specific aspects of BTS operation against individual performance requirements. All testing is performed using the CDMA LMF *GUI* environment.

### TX Testing

TX tests verify any given transmit antenna path and output power control. All tests are performed using the external calibrated test set. All measurements are via the appropriate **TX OUT** connector.

TX tests verify TX operation of the entire CDMA Forward Link using all BBXs assigned to all respective sector/antennas. Each BBX is keyed up to generate a CDMA carrier (using both bbx level and bay level offsets) at the cdf file carrier output power level (as specified in the site documentation).

### RX Testing

RX testing verifies any given receive antenna path. All tests are performed using the external calibrated test set to inject a *CDMA* RF carrier with all zero longcode at the specified RX frequency via the appropriate **RX IN** connector.

RX tests verify RX operation of the entire CDMA Reverse Link using all equipped BDC/MCCs assigned to all respective sector/antennas.

## Individual Tests

### Spectral Purity TX Mask

This test verifies that the transmitted CDMA carrier waveform generated on each sector meets the transmit spectral mask specification (as defined in IS-97) with respect to the assigned cdf file values.

### Waveform Quality (Rho)

This test verifies that the transmitted Pilot channel element digital waveform quality (rho) exceeds the minimum specified value in IS-97. *Rho* represents the correlation between the actual and perfect CDMA modulation spectrums. 1.0000 represents 100% (or perfect correlation).

### Pilot Time Offset

The Pilot Time Offset is the difference between the CDMA analyzer measurement interval (based on the BTS system time reference) and the incoming block of transmitted data from the BTS (Pilot only, Walsh code 0).

### Code Domain Power/Noise Floor

This test verifies the code domain power levels, which have been set for all ODD numbered Walsh channels, using the OCNS command. This is

done by verifying that the ratio of PILOT divided by OCNS is equal to  $10.2 \pm 2$  dB, and, that the noise floor of all EVEN numbered “OFF” Walsh channels measures  $\leq -27$  dB (with respect to total CDMA channel power).

### BTS Frame Error Rate

This test verifies the BTS receive Frame Error Rate (FER) on all Traffic Channel elements currently configured on all equipped MCCs (fullrate at one percent FER) at an RF input level of  $-119$  dBm on the *main* RX antenna paths using all *equipped* MCCs, BBXs, and BDCs at the site. The *diversity* RX antenna paths are also tested using the lowest equipped MCC/CE ONLY.

#### NOTE

There are no pass/fail criteria associated with FER readings taken at level below  $-119$  dBm, other than to verify that the FER measurement reflects changes in the RX input signal level.



---

# TX Spectral Purity Transmit Mask Acceptance Test

## Background

This test verifies the spectral purity of each BBX carrier keyed up at a specific frequency *per the current CDF file assignment*. All tests are performed using the external calibrated test set controlled by the same command. All measurements are via the appropriate **TX OUT** connector.

The BDC Pilot Gain will be set to to 541 for each antenna, and the forward link will be disabled for all TCH elements from the MCCs. The BBX will be keyed up using both `bbxlvl` and bay level offsets, to generate a CDMA carrier (with pilot channel element only). RF output will be set at 40 dBm as measured at the appropriate TX output.

The calibrated communications test set will measure and return the attenuation level of all spurious and IM products with respect to the mean power of the CDMA channel measured in a 1.23 MHz bandwidth, in dB, verifying that results meet system tolerances at the following test points (see also Figure 4-1):

- At least **-45 dB @ + 750 kHz** from center frequency.
- At least **-45 dB @ - 750 kHz** from center frequency.
- At least **-60 dB @ + 900 kHz** from center frequency.
- At least **-60 dB @ - 900 kHz** from center frequency.
- At least **-60 dB @ -1980 kHz** from center frequency.
- At least **-60 dB @ + 1980 kHz** from center frequency.

### NOTE

Spurious and IM products at  $\pm 900$  kHz from center frequency are also measured, but there is no pass/fail criteria. This measurement is provided for information purposes only.

The BBX will then dekey, and if selected, the BDC will be re-configured to assign the applicable redundant BBX to the current TX antenna path under test. The test will then be repeated.

## TX Spectral Purity Transmit Mask Acceptance Test – continued

### Spectral Purity TX Mask Acceptance Test

Follow the steps in Table 4-5 to verify the transmit spectral mask specification on all TX antenna paths using all BBXs equipped at the BTS.

**Table 4-5:** Test Spectral Purity Transmit Mask

Step	Action
1	Set up the test equipment for TX acceptance tests per Table 4-1.
2	Select the BBXs to be tested.
3	From the <b>Tests</b> menu, select <b>TX Mask</b> .
4	Select the appropriate carrier(s) (carrier-bts#-sector#-carrier#) displayed in the <b>Channels/Carrier</b> pick list. <b>NOTE</b> To select multiple items, hold down the <b>Shift</b> or <b>Ctrl</b> key while making the selections.
5	Enter the appropriate channel number in the <b>Carrier n Channels</b> box.
6	Click <b>OK</b> . The status report window is displayed and a <b>Directions</b> pop-up is displayed.
7	Follow the cable connection directions as they are displayed. The test results are displayed in the status report window.
8	Click <b>Save Results</b> or <b>Dismiss</b> . <b>NOTE</b> If <b>Dismiss</b> is used, the test results <b>will not</b> be saved in the test report file.

Figure 4-1: TX Mask Verification Spectrum Analyzer Display

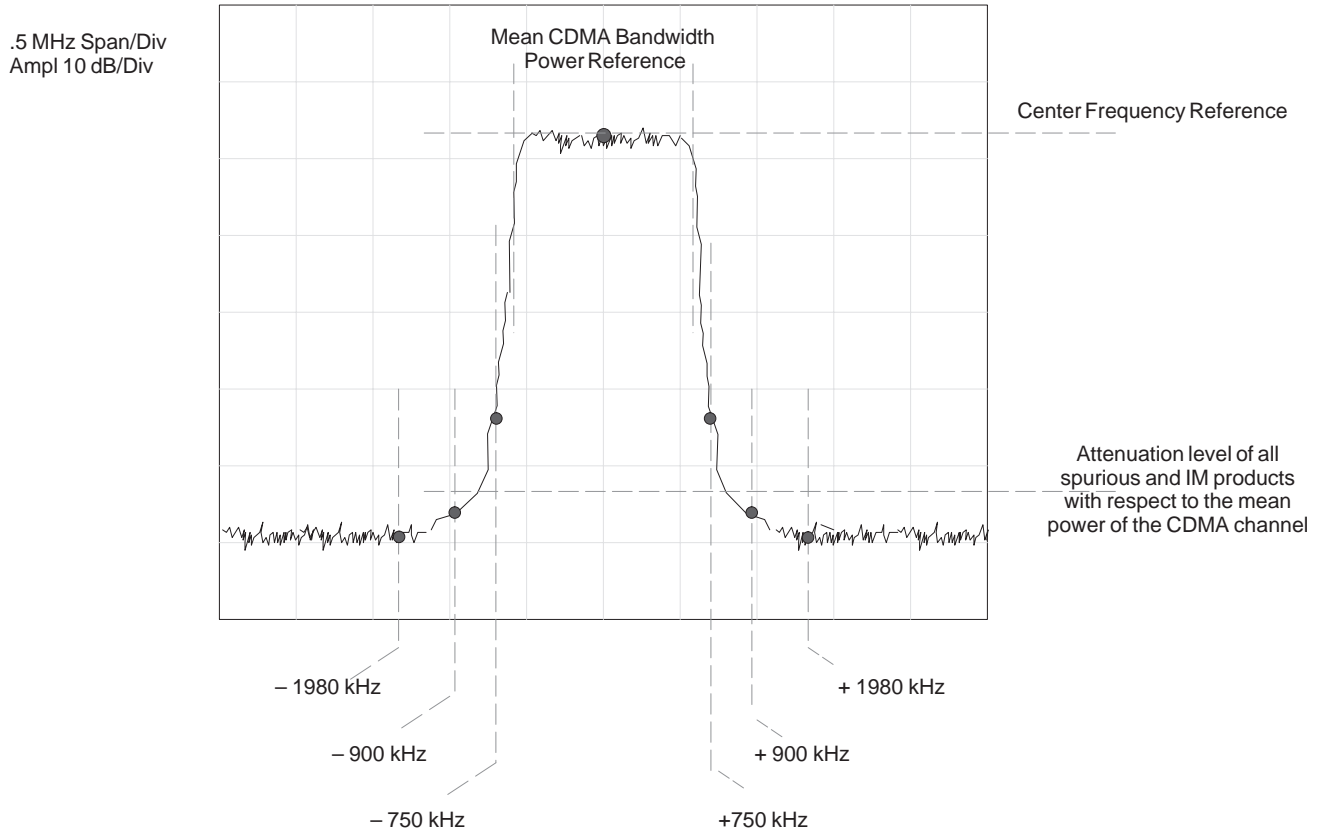

4

# TX Waveform Quality (Rho) Acceptance Test

## Background

This test verifies the transmitted Pilot channel element digital waveform quality of each BBX carrier keyed up at a specific frequency *per the current CDF file assignment*. All tests are performed using the external calibrated test set controlled by the same command. All measurements are via the appropriate **TX OUT** connector.

The BDC Pilot Gain will be set to 262 for each antenna, and all TCH elements from the MCCs will be forward link disabled. The BBX will be keyed up using both bblvl and bay level offsets to generate a CDMA carrier (with pilot channel element only, Walsh code 0). RF output power is set at 40 dBm as measured at the appropriate TX output.

The calibrated communications test set will measure and return the Pilot channel element digital waveform quality (rho) percentage, verifying that the result meets system tolerances:

Waveform quality (Rho) should be > **0.912 (-0.4 %)**.

The BBX will then de-key, and if selected, the BDC will be re-configured to assign the applicable redundant BBX to the current TX antenna path under test. The test will then be repeated.

## Waveform Quality (Rho) Acceptance Test

Follow the steps in Table 4-6 to verify the Pilot channel element waveform quality (rho) on the specified TX antenna paths using BBXs and BDCs equipped at the BTS.

Step	Action
1	Set up the test equipment for TX acceptance tests per Table 4-1.
2	Select the BBXs to be tested.
3	From the <b>Tests</b> menu, select <b>Rho</b> .
4	Select the appropriate carrier(s) (carrier-bts#-sector#-carrier#) displayed in the <b>Channels/Carrier</b> pick list. <b>NOTE</b> To select multiple items, hold down the <b>Shift</b> or <b>Ctrl</b> key while making the selections.
5	Enter the appropriate channel number in the <b>Carrier n Channels</b> box.
6	Click <b>OK</b> . The status report window is displayed and a <b>Directions</b> pop-up is displayed.
7	Follow the cable connection directions as they are displayed. The test results are displayed in the status report window.
8	Click <b>Save Results</b> or <b>Dismiss</b> . <b>NOTE</b> If <b>Dismiss</b> is used, the test results <b>will not</b> be saved in the test report file.

# TX Pilot Time Offset Acceptance Test

## Background

This test verifies the transmitted Pilot channel element Pilot Time Offset of each BBX carrier keyed up at a specific frequency *per the current CDF file assignment*. All tests will be performed using the external calibrated test set controlled by the same command. All measurements will be via the **TX OUT** connector.

The BDC Pilot Gain will be set to to 262 for each antenna and all TCH elements from the MCCs will be forward link disabled. The BBX will be keyed up using both bblvl and bay level offsets to generate a CDMA carrier (with pilot channel element only, Walsh code 0). TX power output is set at 40 dBm as measured at the TX output.

The calibrated communications test set will measure and return the Pilot Time Offset in  $\mu\text{s}$ , verifying that results meet system tolerances:

Pilot Time Offset should be within **3  $\mu\text{s}$**  of the target PT Offset (zero  $\mu\text{s}$ ).

The BBX will then de-key, and if selected, the BDC will be re-configured to assign the applicable redundant BBX to the current TX antenna path under test. The test will then be repeated.

### NOTE

This test also executes and returns the TX Frequency and TX Waveform Quality (rho) ATP tests, however, only *Pilot Time Offset* results are written to the ATP test report.

## Pilot Time Offset Acceptance Test

Follow the steps in Table 4-7 to verify the Pilot Time Offset on the specified TX antenna paths using BBXs and BDCs equipped at the BTS.

**Table 4-7:** Test Pilot Time Offset

Step	Action
1	Set up the test equipment for TX acceptance tests per Table 4-1.
2	Select the BBXs to be tested.
3	From the <b>Tests</b> menu, select <b>Pilot Time Offset</b> .
4	Select the appropriate carrier(s) (carrier-bts#-sector#-carrier#) displayed in the <b>Channels/Carrier</b> pick list. <b>NOTE</b> To select multiple items, hold down the <b>Shift</b> or <b>Ctrl</b> key while making the selections.
5	Enter the appropriate channel number in the <b>Carrier n Channels</b> box.
6	Click <b>OK</b> . The status report window is displayed and a <b>Directions</b> pop-up is displayed.

. . . continued on next page

---

## TX Pilot Time Offset Acceptance Tests – continued

**Table 4-7:** Test Pilot Time Offset

Step	Action
7	Follow the cable connection directions as they are displayed. The test results are displayed in the status report window.
8	Click <b>Save Results</b> or <b>Dismiss</b> .  <b>NOTE</b> If <b>Dismiss</b> is used, the test results <b>will not</b> be saved in the test report file.

---

# TX Code Domain Power/Noise Floor Acceptance Test

## Background

This test verifies the Code Domain Power and Noise Floor of each BBX carrier keyed up at a specific frequency *per the current CDF file assignment*. All tests are performed using the external calibrated test set controlled by the same command. All measurements are via the appropriate **TX OUT** connector.

The BDC Pilot Gain will be set to 262 for each antenna and all equipped MCCs will be configured to supply all odd-numbered Walsh code Traffic channel elements by enabling Orthogonal Channel Noise Source (OCNS) on all odd MCC/CEs, (maximum 32 full rate channels with an OCNS gain of 81). All even-numbered Walsh code Traffic channel elements will not have OCNS enabled, and are considered “OFF”. All equipped MCCs will be forward link enabled for the antenna/sector under test.

The BBX will be keyed up using both `bbxlvl` and bay level offsets, to generate a CDMA carrier consisting of pilot and OCNS channels. RF output power is set at 40 dBm as measured at the appropriate TX output.

The calibrated communications test set will measure and return the channel element power (dB) of all specified Walsh channels within the CDMA spectrum. Additional calculations will be performed to verify the following parameters are met (Figure 4-2):

- Traffic channel element power level will be verified by calculating the ratio of PILOT power to OCNS gain of all traffic channels (root sum of the square (RSS) of each OCNS gain divided by the Pilot power). This value should be **10.2 dB ± 2.0 dB**.
- Noise floor (unassigned “OFF” even numbered Walsh channels) are verified to be **≤ -27 dB** (with respect to total CDMA channel power).

The BBX will then de-key, and if selected, the BDC will be re-configured to assign the applicable redundant BBX to the current TX antenna path under test. The test will then be repeated. Upon completion of the test, OCNS channels will be disabled on the specified MCC/CEs.

## Code Domain Power/Noise Floor Test

Follow the steps in Table 4-8 to verify the Code Domain Power/Noise floor of each BBX carrier keyed up at a specific frequency.

**TX Code Domain Power/Noise Floor Acceptance Test** – continued

**Table 4-8:** Test Code Domain Power/Noise Floor

Step	Action
1	Set up the test equipment for TX acceptance tests per Table 4-1.
2	Select the BBXs and MCCs to be tested.
3	From the <b>Tests</b> menu, select <b>TX Mask</b> .
4	Select the appropriate carrier(s) (carrier-bts#-sector#-carrier#) displayed in the <b>Channels/Carrier</b> pick list.  <b>NOTE</b> To select multiple items, hold down the <b>Shift</b> or <b>Ctrl</b> key while making the selections.
5	Enter the appropriate channel number in the <b>Carrier n Channels</b> box.
6	Click <b>OK</b> . The status report window is displayed and a <b>Directions</b> pop-up is displayed.
7	Follow the cable connection directions as they are displayed. The test results are displayed in the status report window.
8	Click <b>Save Results</b> or <b>Dismiss</b> .  <b>NOTE</b> If <b>Dismiss</b> is used, the test results <b>will not</b> be saved in the test report file.

4



# TX Code Domain Power/Noise Floor Acceptance Test – continued

**Figure 4-2:** Code Domain Analyzer CD Power/Noise Floor Display Examples

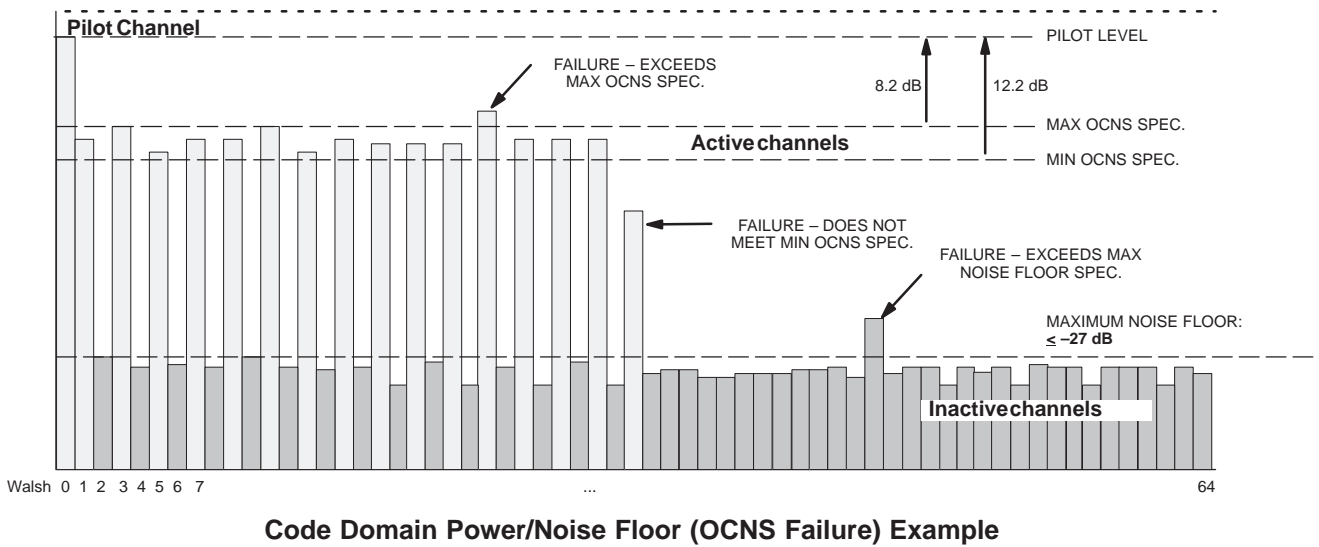
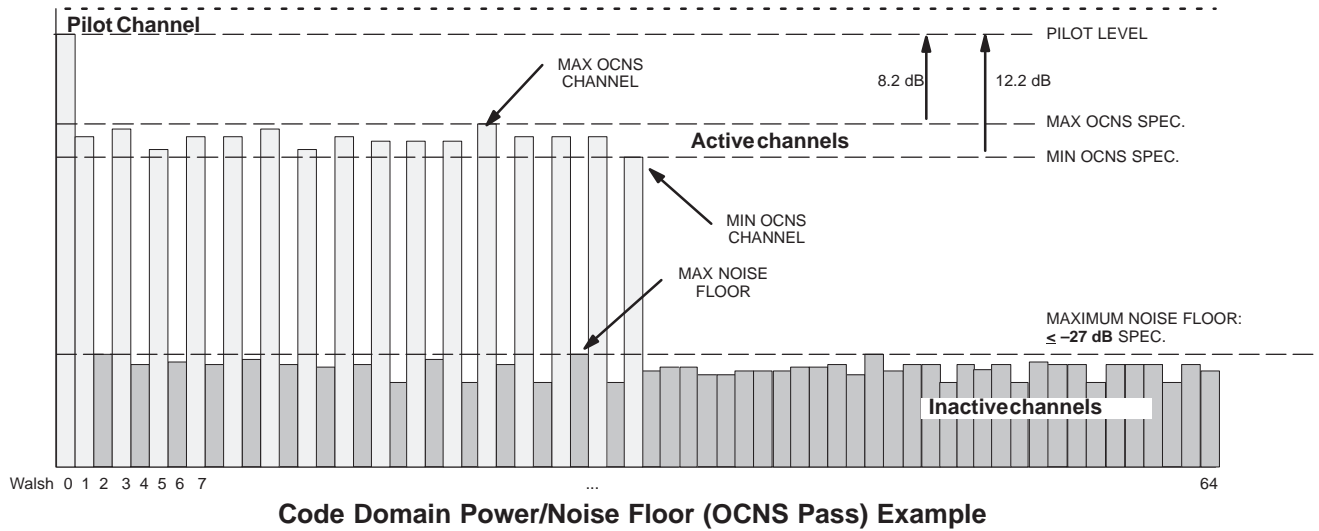

---

# RX FER Acceptance Test

## Background

This test verifies the BTS Frame Erasure Rate (FER) on *all* Traffic Channel elements currently configured on *all* equipped MCCs (fullrate at 1% FER) at -119 dBm on the *main* RX antenna paths. The test is performed on all *diversity* RX antenna path using only the lowest equipped MCC/CE. All tests are performed using the external calibrated test set as the signal source controlled by the same command. All measurements are via the LMF.

The BDC Pilot Gain will be set to 262 for each TX antenna, and the forward link for all TCH elements from the MCCs will be disabled. The BBX will be keyed up using only *bbxlvl* level offsets, to generate a CDMA carrier (with pilot channel element only). TX power output is set at +10 dBm. (The BBX must be keyed in order to enable the RX receive circuitry.)

The LMF will prompt the MCC/CE under test to measure all-zero longcode and provide the Frame Erasure Rate (FER) report on the selected active MCC on the Reverse Link for both the main and diversity RX antenna paths, verifying results meet the following specification:

FER returned less than **1%** and Total Frames measured is **1500**.

The BBX will then de-key, and if selected, the BDC will be re-configured to assign the applicable redundant BBX to the current RX antenna paths under test. The test will then be repeated.



## RX FER Acceptance Test – continued

### FER Acceptance Test

Follow the steps in Table 4-9 to verify the FER on all RX antenna paths using all BBXs equipped at the BTS.

<b>Table 4-9: Test FER</b>	
<b>Step</b>	<b>Action</b>
1	Set up the test equipment for RX acceptance tests per Table 4-1.
2	Select the BBXs and MCCs to be tested.
3	From the <b>Tests</b> menu, select <b>FER</b> .
4	Select the appropriate carrier(s) (carrier-bts#-sector#-carrier#) displayed in the <b>Channels/Carrier</b> pick list. <b>NOTE</b> To select multiple items, hold down the <b>Shift</b> or <b>Ctrl</b> key while making the selections.
5	Enter the appropriate channel number in the <b>Carrier n Channels</b> box.
6	From the <b>RX Branch</b> pick list, select the branch/branches to be tested.
7	Select the desired rate from the <b>Rate Set</b> pick list (1 = 9600, 2 = 14400).
8	Click <b>OK</b> . The status report window is displayed and a <b>Directions</b> pop-up is displayed.
9	Follow the cable connection directions as they are displayed. The test results are displayed in the status report window.
10	Click <b>Save Results</b> or <b>Dismiss</b> . <b>NOTE</b> If <b>Dismiss</b> is used, the test results <b>will not</b> be saved in the test report file.

---

# Generating an ATP Report

## Background

Each time an ATP test is run, an ATP report is updated and must be saved using the **Save Results** button to close the status report window. The ATP report *will not* be updated if the status reports window is closed using the **Dismiss** button.

## ATP Report

A separate report is created for each BTS and includes the following for each test:

- Test name
- PASS or FAIL
- Description information (if applicable)
- BBX number
- BDC number
- Channel number
- Carrier number
- Sector number
- Upper test limit
- Lower test limit
- Test result
- Time stamp
- Details/Warning information (if applicable)

Follow the procedures in the Table 4-10 to view and create a printable file for the ATP report.

**Table 4-10:** Generating an ATP Report

Step	Action
1	Click on the <b>Login</b> tab (if not in the forefront).
2	Select the desired BTS from the available Base Station pick list.
3	Click on the <b>Report</b> button.
4	Click on a column heading to start the report.
5	If not desiring a printable file copy, click on the <b>Dismiss</b> button.
6	If requiring a printable file copy, select the desired file type in the pick list and click on the <b>Save</b> button.

## Chapter 5: Leaving the Site

### Table of Contents

---

Updating Calibration Data Files .....	5-1
Updating CBSC Calibration Data Files .....	5-1
Prepare to Leave the Site .....	5-3
Removing External Test Equipment .....	5-3
Reset All Devices and Initialize Site Remotely .....	5-3
Bringing Modules into Service with the CDMA LMF .....	5-3
Terminating LMF Session/Removing Terminal .....	5-4
Connecting BTS T1 Spans .....	5-5



# Updating Calibration Data Files

## Updating CBSC Calibration Data Files

After completing the TX calibration and audit, updated CAL file information must be moved from the LMF Windows environment back to the CBSC, a Unix environment. The following procedures detail moving files from one environment to the other.

### Copying CAL files from LMF to a Disk

Follow the procedures in Table 5-1 to copy the CAL files from a CDMA LMF computer to a 3.5 diskette.

Step	Action
1	With Windows running on the CDMA LMF computer, insert a disk into Drive A:.
2	Launch the <b>Windows Explorer</b> Program from your <b>Programs</b> menu list.
3	Select the applicable <b>wlmf/cdma/bts-#</b> folder.
4	Drag the <b>bts-#.cal</b> file to Drive A.
5	Repeat Steps 3 and 4, as required, for other <b>bts-#</b> folders.



### Copying CAL Files from Diskette to the CBSC

Follow the procedures in Table 5-2 to copy CAL files from a diskette to the CBSC.

Step	Action
1	Log in to the CBSC on the OMC-R Unix workstation using your account name and password.
2	Place your diskette containing calibration file(s) in the workstation diskette drive.
3	Type in <b>eject -q</b> and press the Enter key.
4	Type in <b>mount</b> and press the Enter key. <b>NOTE</b> <ul style="list-style-type: none"><li>• Check to see that the message “<i>floppy/no_name</i>” is displayed on the last line.</li><li>• If the <b>eject</b> command was previously entered, <i>floppy/no_name</i> will be appended with a number. Use the explicit <i>floppy/no_name</i> reference displayed.</li></ul>
5	Type in <b>cd /floppy/no_name</b> and press the Enter key.
6	Type in <b>ls -lia</b> and press the Enter key. Verify that the <b>bts-#.cal</b> file is on the diskette.
7	Type in <b>cd</b> and press the Enter key.
8	Type in <b>pwd</b> and press the Enter key. Verify you are in your home directory ( <i>/home/&lt;name&gt;</i> ).

... continued on next page

**Table 5-2:** Copying CAL Files from Diskette to the CBSC

Step	Action
9	<p>With <i>Solaris versions of Unix</i>, create a Unix-formatted version of the <code>bts-#.cal</code> file in your home directory by entering the following command:</p> <p><b>dos2unix /floppy/no_name/bts-#.cal bts-#.cal</b> and press the Enter key (where # is BTS number).</p> <p><b>NOTE</b></p> <p>Other versions of Unix do not support the <code>dos2unix</code> command. In these cases, use the Unix <code>cp</code> (copy) command. The <i>copied</i> files will contain DOS line feed characters which must be edited out with a Unix text editor.</p>
10	Type in <code>ls -l *.cal</code> and press the Enter key. Verify the cal files have been copied.
11	Type in <code>eject</code> and press the Enter key.
12	Remove the diskette from the workstation.



## Prepare to Leave the Site

### Removing External Test Equipment

Perform the procedure in Table 5-3 to disconnect the test equipment and configure the BTS for active service.

Table 5-3: Remove External Test Equipment	
Step	Action
1	Disconnect all external test equipment from all TX and RX connectors on the top of the frame.
2	Reconnect and visually inspect all TX and RX antenna feed lines at the top of the frame.
	<b>! CAUTION</b> Verify that all sector antenna feed lines are connected to the correct ports on the frame. Crossed antenna cables will cause system degradation of call processing.

### Reset All Devices and Initialize Site Remotely

Generally, devices in the BTS should not be left with data and code loaded from the CDMA LMF. The configuration data and code loads used for normal operation could be different from those stored in the CDMA LMF files. By resetting all devices, the required data and code can be loaded from the CBSC when spans are again active.

To reset all devices and have the OMCR/CBSC bring up the site remotely, perform the procedure in Table 5-4.

Table 5-4: Reset BTS Devices and Remote Site Initialization	
Step	Action
1	Terminate the CDMA LMF session by following the procedures in Table 5-6.
2	Cycle BTS power off and on.
3	Reconnect spans by following the procedures in Table 5-7.
4	Notify the OMCR/CBSC to take control of the site and download code and data to the BTS.
5	Verify the CBSC can communicate with the GLIs.

### Bringing Modules into Service with the CDMA LMF



#### IMPORTANT

Whenever possible, have the CBSC/MM bring up the site and enable all devices at the BTS.

If there is a reason code and/or data should or could not be loaded remotely from the CBSC, follow the steps outlined in Table 5-5 *as required* to bring BTS processor modules from the OOS to INS mode.

**Table 5-5: Bring Modules into Service**

Step	Action
1	In the CDMA LMF <i>GUI</i> environment, select the device(s) you wish to enable.  <b>NOTE</b> <ul style="list-style-type: none"> <li>• The MGLI, CSM, and applicable BDC must be INS before an MCC can be enabled to INS.</li> <li>• Processors which must be enabled and the order of enabling are as follows:                             <ul style="list-style-type: none"> <li>– MGLI</li> <li>– GLI</li> <li>– CSMs</li> <li>– BDCs</li> <li>– MCCs</li> <li>– Gateways</li> </ul> </li> </ul>
2	Click on <b>Device</b> from the menu bar.
3	Click on <b>Enable</b> from the <b>Device</b> menu. A status report window is displayed.  <b>NOTE</b> If a BBX is selected, a transceiver parameters window is displayed to collect keying information. Do not enable the BBX.
4	Click <b>Cancel</b> to close the transceiver parameters window, if applicable.
5	Click <b>OK</b> to close the status report window.  The selected devices that successfully change to INS change color to green.

**Terminating LMF Session/Removing Terminal**

Perform the procedure in Table 5-6 as required to terminate the LMF *GUI* session and remove the CDMA LMF computer.

**Table 5-6: Remove LMF**

Step	Action
	<b>! CAUTION</b> Do not power down the CDMA LMF terminal without performing the procedure below. Corrupted/lost data files may result.
1	Log out of all BTS sessions and exit CDMA LMF by clicking on the <b>File</b> selection in the menu bar and selecting <b>Exit</b> from the <b>File</b> menu list.
2	Click <b>Yes</b> in the <b>Confirm Logout</b> pop-up message which appears.
3	In the Windows Task Bar, click <b>Start</b> and select <b>Shutdown</b> .
4	Click <b>Yes</b> when the Shut Down Windows message appears
5	Wait for the system to shut down and the screen to go blank.

... continued on next page

---

## Prepare to Leave the Site – continued

**Table 5-6:** Remove LMF

<b>Step</b>	<b>Action</b>
6	Disconnect the CDMA LMF terminal Ethernet port from the BTS cabinet.
7	Disconnect the CDMA LMF terminal serial port, the RS-232-to-GPIB interface box, and the GPIB cables as required for equipment transport.

### Connecting BTS T1 Spans

Before leaving the site, connect any T1 span surge suppressors removed previously to allow the LMF to control the BTS. Refer to Table 5-7 and NO TAG as required.

**Table 5-7:** Connect T1 Span/Modem Cable

<b>Step</b>	<b>Action</b>
1	Re-connect and disconnected span surge suppressors on the 50-pin punchblock.
2	If equipped, ensure the CSU is powered on.
3	Verify span status, ensuring the OMC-R/CBSC can communicate with the BTS.



## Chapter 6: Basic Troubleshooting

### Table of Contents

---

Basic Troubleshooting Overview .....	6-1
Overview .....	6-1
Troubleshooting: Installation .....	6-2
Cannot Log into Cell-Site .....	6-2
Cannot Communicate to Power Meter .....	6-2
Cannot Communicate to Communications Analyzer .....	6-3
Troubleshooting: Download .....	6-4
Cannot Download DATA to Any Device (Card) .....	6-4
Cannot ENABLE Device .....	6-5
LPA Errors .....	6-6
Troubleshooting: Calibration .....	6-7
Bay Level Offset Calibration Failure .....	6-7
Calibration Audit Failure .....	6-8
Troubleshooting: Transmit ATP .....	6-9
Cannot Perform Txmask Measurement .....	6-9
Cannot Perform Rho or Pilot Time Offset Measurement .....	6-9
Cannot Perform Code Domain Power and Noise Floor Measurement .	6-10
Cannot Perform Carrier Measurement .....	6-10
Troubleshooting: Receive ATP .....	6-11
Multi-FER Test Failure .....	6-11
Troubleshooting: CSM Checklist .....	6-12
Problem Description .....	6-12
Intermittent 19.6608 MHz Reference Clock / GPS Receiver Operation	6-12
No GPS Reference Source .....	6-12
Checksum Failure .....	6-12
GPS Bad RX Message Type .....	6-12
CSM Reference Source Configuration Error .....	6-12
Takes Too Long for CSM to Come INS .....	6-13
SCCP Backplane Troubleshooting .....	6-14
Introduction .....	6-14
Connector Functionality .....	6-14
SCCP Backplane Troubleshooting Procedure .....	6-15
Digital Control Problems .....	6-16
DC Power Problems .....	6-18
TX and RX Signal Routing Problems	
.....	6-19

---

## Table of Contents – continued

RFDS – Fault Isolation .....	6-20
Introduction .....	6-20
All tests fail .....	6-20
All RX and TX paths fail .....	6-20
All tests fail on a single antenna .....	6-21
Module Front Panel LED Indicators and Connectors .....	6-22
Module Status Indicators .....	6-22
LED Status Combinations for All Modules (except GLI2, CSM, BBX2, MCC24, MCC8E) .....	6-22
DC/DC Converter LED Status Combinations .....	6-22
CSM LED Status Combinations .....	6-23
GLI2 LED Status Combinations .....	6-25
GLI2 Pushbuttons and Connectors .....	6-26
BBX2 LED Status Combinations .....	6-27
MCC24 LED Status Combinations .....	6-27
LPA Shelf LED Status Combinations .....	6-28
Basic Troubleshooting – Span Control Link .....	6-29
Span Problems (No Control Link) .....	6-29
Set BTS Site Span Configuration .....	6-30

---

## Basic Troubleshooting Overview

### Overview

The information in this chapter addresses some of the scenarios likely to be encountered by Customer Field Engineering (CFE) team members. This troubleshooting guide was created as an interim reference document for use in the field. It provides basic “what to do if” basic troubleshooting suggestions when the BTS equipment does not perform per the procedure documented in the manual.

Comments are consolidated from inputs provided by CFEs in the field and information gained from experience in Motorola labs and classrooms.

## Troubleshooting: Installation

### Cannot Log into Cell-Site

Table 6-1: Login Failure Troubleshooting Procedures		
✓	Step	Action
	1	If MGLI2 LED is solid RED, it implies a hardware failure. Reset MGLI2 by re-seating it. If this persists, install RGLI2 card in MGLI2 slot and retry. A Red LED may also indicate no Ethernet termination at top of frame.
	2	Verify that T1 is disconnected at the Channel Signaling Unit (CSU). If T1 is still connected, verify the CBSC has disabled the BTS.
	3	Try 'ping'ing the MGLI2.
	4	Verify the LMF is connected to the <b>Primary</b> LMF port (LAN A) in front of the BTS.
	5	Verify the LMF was configured properly.
	6	If a Xircom parallel BNC LAN interface is being used, verify the BTS-LMF cable is RG-58 (flexible black cable of less than 2.5 feet length).
	7	Verify the Ethernet ports are terminated properly.
	8	Verify a T-adapter is <u>not</u> used on LMF side port if connected to the BTS front LMF primary port.
	9	Try connecting to the Ethernet Out port in the power entry compartment (back of frame). Use Triax to BNC adapter at the LMF port for this connection.
	10	Re-boot the CDMA LMF and retry.
	11	Re-seat the MGLI2 and retry.
	12	Verify IP addresses are configured properly.

### Cannot Communicate to Power Meter

Table 6-2: Troubleshooting a Power Meter Communication Failure		
✓	Step	Action
	1	Verify Power Meter is connected to LMF with GPIB adapter.
	2	Verify cable setup as specified in Chapter 3.
	3	Verify the GP-IB address of the Power Meter is set to 13. Refer to Test Equipment setup section of Chapter 3 for details.
	4	Verify that Com1 port is not used by another application.
	5	Verify that the communications analyzer is in Talk&Listen, not Control mode.



### Cannot Communicate to Communications Analyzer

<b>Table 6-3: Troubleshooting a Communications Analyzer Communication Failure</b>		
	<b>Step</b>	<b>Action</b>
	1	Verify analyzer is connected to LMF with GPIB adapter.
	2	Verify cable setup.
	3	Verify the GPIB address is set to 18.
	4	Verify the GPIB adapter DIP switch settings are correct. Refer to Test Equipment setup section for details.
	5	Verify the GPIB adapter is not locked up. Under normal conditions, only 2 green LEDs must be 'ON' (Power and Ready). If any other LED is continuously 'ON', then power-cycle the GPIB Box and retry.
	6	If a Hyperterm window is open for MMI, close it.
	7	Verify the LMF GPIB address is set to 18.
	8	Verify the analyzer is in Talk and Listen not Control mode.

## Troubleshooting: Download

Table 6-4: Troubleshooting Code Download Failure		
✓	Step	Action
	1	Verify T1 is disconnected from the BTS at CSU.
	2	Verify LMF can communicate with the BTS device using the Status function.
	3	Communication to MGLI2 must first be established before trying to talk to any other BTS device. MGLI2 must be INS_ACT state (green).
	4	Verify the card is physically present in the cage and powered-up.
	5	If card LED is solid RED, it implies hardware failure. Reset card by re-seating it. If this persists, replace card from another slot & retry.  <b>NOTE</b> The card can only be replaced by a card of the same type.
	6	Re-seat card and try again.
	7	If BBX2 reports a failure message and is OOS_RAM, the code load was OK. Status it.
	8	If the download portion completes and the reset portion fails, reset the device by selecting the device and reset.

### Cannot Download DATA to Any Device (Card)

Table 6-5: Troubleshooting Data Download Failure		
✓	Step	Action
	1	Re-seat card and repeat code and data load procedure.
	2	Verify the ROM and RAM code loads are of the same release by statusing the card. Refer to Chapter 3, "Download the BTS" for more information.

### Cannot ENABLE Device

Before a device can be enabled (placed in-service), it must be in the OOS\_RAM state (yellow on the LMF) with data downloaded to the device. The color of the device on the LMF changes to green, once it is enabled.

The three states that devices can be displayed:

- Enabled (green, INS)
- Disabled (yellow, OOS\_RAM)
- Reset (blue, OOS\_ROM)

**Table 6-6:** Troubleshooting Device Enable (INS) Failure

✓	Step	Action
	1	Re-seat card and repeat code and data load procedure.
	2	If CSM cannot be enabled, verify the CDF file has correct latitude and longitude data for cell site location and GPS sync.
	3	Ensure primary CSM is in INS_ACT state. <b>NOTE</b> MCCs will not go INS without the CSM being INS.
	4	Verify 19.6608 MHz CSM clock is present; MCCs will not go INS without it.
	5	BBXs should not be enabled for ATP tests.
	6	If MCCs give “invalid or no system time,” verify the CSM is enabled.

**LPA Errors**

<b>Table 6-7: LPA Errors</b>		
	<b>Step</b>	<b>Action</b>
	1	If LPAs continue to give alarms, even after cycling power at the circuit breakers, then connect an MMI cable to the LPA and set up a Hyperterminal connection. Enter <b>ALARMS</b> in the Hyperterminal window. The resulting LMF display may provide an indication of the problem. (Call Field Support for further assistance.)

# Troubleshooting: Calibration

## Bay Level Offset Calibration Failure

**Table 6-8: Troubleshooting BLO Calibration Failure**

✓	Step	Action
	1	Verify the Power Meter is configured correctly (see the test equipment setup section) and connection is made to the proper TX port.
	2	Verify the parameters in the bts-#.cdf file are set correctly for the following bands: For 1900 MHz: Bandclass=1; Freq_Band=16 For 800 MHz: Bandclass=0; Freq_Band=8
	3	Verify that no LPA in the sector is in alarm state (flashing red LED). Reset the LPA by pulling the circuit breaker, and, after 5 seconds, pushing back in.
	4	Re-calibrate the Power Meter and verify it is calibrated correctly with cal factors from the power sensor.
	5	Verify GPIB adapter is not locked up. Under normal conditions, only 2 green LEDs must be 'ON' (Power and Ready). If any other LED is continuously 'ON', power-cycle (turn power off and on) the GP-IB Box and retry.
	6	Verify the power sensor is functioning properly by checking it with the 1-mW (0 dBm) Power Ref signal.
	7	If communication between the LMF and Power Meter is working, the Meter display will show "RES :"
	8	Verify the combiner frequency is the same as the test freq/chan.



Calibration Audit Failure

Table 6-9: Troubleshooting Calibration Audit Failure		
✓	Step	Action
	1	Verify Power Meter is configured correctly (refer to the test equipment setup section).
	2	Re-calibrate the Power Meter and verify it is calibrated correctly with cal factors from the power sensor.
	3	Verify that no LPA is in alarm state (rapidly flashing red LED). Reset the LPA by pulling the circuit breaker, and, after 5 seconds, pushing back in.
	4	Verify the power sensor is functioning properly by checking it with the 1 mW (0 dBm) Power Ref signal.
	5	After calibration, the BLO data must be re-loaded to the BBXs before auditing. Click on the BBX(s) and select <b>Download Code&gt;Download Data&gt;Enable</b> . Re-try the audit.
	6	Verify GPIB adapter is not locked up. Under normal conditions, only 2 green LEDs must be 'ON' (Power and Ready). If any other LED is continuously 'ON', power-cycle (turn power off and on) the GP-IB Box and retry.

## Troubleshooting: Transmit ATP

### Cannot Perform Txmask Measurement

Table 6-10: Troubleshooting TX Mask Measurement Failure		
✔	Step	Action
	1	Verify that TX audit passes for the BBX2(s).
	2	If performing manual measurement, verify analyzer setup.
	3	Verify that no LPA in the sector is in alarm state (flashing red LED). Re-set the LPA by pulling the circuit breaker, and, after 5 seconds, pushing it back in.

### Cannot Perform Rho or Pilot Time Offset Measurement

Table 6-11: Troubleshooting Rho and Pilot Time Offset Measurement Failure		
✔	Step	Action
	1	Verify presence of RF signal by switching to spectrum analyzer screen.
	2	Verify PN offsets displayed on the analyzer is the same as the PN offset in the CDF file.
	3	Re-load MGLI2 data and repeat the test.
	4	If performing manual measurement, verify analyzer setup.
	5	Verify that no LPA in the sector is in alarm state (flashing red LED). Reset the LPA by pulling the circuit breaker, and, after 5 seconds, pushing back in.
	6	If Rho value is unstable and varies considerably (e.g. .95,.92,.93), this may indicate that the GPS is still phasing (i.e. trying to reach and maintain 0 freq. error). Go to the freq. bar in the upper right corner of the Rho meter and select Hz. Press <Shift-avg> and enter 10, to obtain an average Rho value. This is an indication the GPS has not stabilized before going <i>INS</i> and may need to be re-initialized.

**Cannot Perform Code Domain  
Power and Noise Floor  
Measurement**

<b>Table 6-12: Troubleshooting Code Domain Power and Noise Floor Measurement Failure</b>		
✓	<b>Step</b>	<b>Action</b>
	1	Verify presence of RF signal by switching to spectrum analyzer screen.
	2	Verify PN offset displayed on analyzer is same as PN offset being used in the CDF file.
	3	Disable and re-enable MCC (one or more MCCs based on extent of failure).

**Cannot Perform Carrier  
Measurement**

<b>Table 6-13: Troubleshooting Carrier Measurement Failure</b>		
✓	<b>Step</b>	<b>Action</b>
	1	Perform the test manually, using the spread CDMA signal. Verify High Stability 10 MHz Rubidium Standard is warmed up (60 minutes) and properly connected to test set-up.



---

## Troubleshooting: Receive ATP

### Multi-FER Test Failure

<b>Table 6-14: Troubleshooting Multi-FER Failure</b>		
✓	<b>Step</b>	<b>Action</b>
	1	Verify test equipment set up is correct for a FER test.
	2	Verify test equipment is locked to 19.6608 and even second clocks. The yellow LED (REF UNLOCK) must be OFF.
	3	Verify MCCs have been loaded with data and are INS-ACT.
	4	Disable and re-enable the MCC (1 or more based on extent of failure).
	5	Disable, re-load code and data, and re-enable MCC (one or more MCCs based on extent of failure).
	6	Verify antenna connections to frame are correct based on the directions messages.

# Troubleshooting: CSM Checklist

## Problem Description

Many of the Clock Synchronization Manager (CSM) boards may be resolved in the field before sending the boards to the factory for repair. This section describes known CSM problems identified in field returns, some of which are field-repairable. Check these problems before returning suspect CSM boards.

### Intermittent 19.6608 MHz Reference Clock / GPS Receiver Operation

If having any problems with CSM board kit numbers, SGLN1145 or SGLN4132, check the suffix with the kit number. If the kit has version “AB,” then replace with version “BC” or higher, and return model AB to the repair center.

### No GPS Reference Source

Check the CSM boards for proper hardware configuration. CSM kit SGLN1145, in Slot 1, has an on-board GPS receiver; while kit SGLN4132, in Slot 2, does not have a GPS receiver. Any incorrectly configured board *must* be returned to the repair center. *Do not attempt to change hardware configuration in the field.* Also, verify the GPS antenna is not damaged and is installed per recommended guidelines.

### Checksum Failure

The CSM could have corrupted data in its firmware resulting in a non-executable code. The problem is usually caused by either electrical disturbance, or interruption of data during a download. Attempt another download with no interruptions in the data transfer. Return CSM board back to repair center if the attempt to reload fails.

### GPS Bad RX Message Type

This is believed to be caused by a later version of CSM software (3.5 or higher) being downloaded, via LMF, followed by an earlier version of CSM software (3.4 or lower), being downloaded from the CBSC. Download again with CSM software code 3.5 or higher. Return CSM board back to repair center if attempt to reload fails.

### CSM Reference Source Configuration Error

This is caused by incorrect reference source configuration performed in the field by software download. CSM kit SGLN1145 and SGLN4132 must have proper reference sources configured (as shown below) to function correctly.

CSM Kit No.	Hardware Configuration	CSM Slot No.	Reference Source Configuration
SGLN1145	With GPS Receiver	1	Primary = Local GPS Backup = Either LFR or HSO
SGLN4132	Without GPS Receiver	2	Primary = Remote GPS Backup = Either LFR or HSO

---

## Troubleshooting: CSM Checklist – continued

### Takes Too Long for CSM to Come INS

This may be caused by a delay in GPS acquisition. Check the accuracy flag status and/or current position. Refer to the GSM system time/GPS and LFR/HSO verification section in Chapter 3. At least 1 satellite should be visible and tracked for the “surveyed” mode and 4 satellites should be visible and tracked for the “estimated” mode. Also, verify correct base site position data used in “surveyed” mode.

---

# SCCP Backplane Troubleshooting

## Introduction

The SCCP backplane is a multi-layer board that interconnects all the SCCP modules. The complexity of this board lends itself to possible improper diagnoses when problems occur.

## Connector Functionality

The following connector overview describes the major types of backplane connectors along with the functionality of each. This will allow the Cellular Field Engineer (CFE) to:

- Determine which connector(s) is associated with a specific problem type.
- Allow the isolation of problems to a specific cable or connector.

### Primary “A” and Redundant “B” ISB (Inter Shelf Bus) connectors

The 40 pin ISB connectors provide an interface bus from the master GLI2 to all other GLI2s in the modem frame. Its basic function is to provide clock synchronization from the master GLI2 to all other GLI2s in the frame.

The ISB is also provides the following functions:

- Span line grooming when a single span is used for multiple cages
- Provide MMI connection to/from the master GLI2 to cell site modem
- Provide interface between GLI2s and the AMR (for reporting BTS alarms)

### Span Line Connector

The span line input is an 8 pin RJ-45 connector that provides a primary and secondary (if used) span line interface to each GLI2 in the SCCP shelf. The span line is used for MM/EMX switch control of the Master GLI2 and also all the BBX2 traffic.

### Power Input (Return A and B connectors)

Provides a 27 volt input for use by the power supply modules.

### Power Supply Module Interface

Each power supply module has a series of three different connectors to provide the needed inputs/outputs to the SCCP backplane. These include a VCC/Ground input connector, a Harting style multiple pin interface, and a +15V/Analog Ground output connector. The Transceiver Power Module converts 27/48 Volts to a regulated +15, +6.5, +5.0 volts to be used by the SCCP shelf cards.

### GLI2 Connector

This connector consists of a Harting 4SU digital connector and a 6-conductor coaxial connector for RDM distribution. The connectors provide inputs/outputs for the GLI2s in the SCCP backplane.

### GLI2 Ethernet “A” and “B” Connections

These BNC connectors are located on the SCCP backplane and routed to the GLI2 board. This interface provides all the control and data communications between the master GLI2 and the other GLI2, between gateways, and for the LMF on the LAN.

### BBX2 Connector

Each BBX2 connector consists of a Harting 2SU/1SU digital connector and two 6-conductor coaxial connectors. These connectors provide DC, digital, and RF inputs/outputs for the BBX2s in the SCCP backplane.

### CIO Connectors

- RX RF antenna path signal inputs are routed through RX Tri-Filters (on the I/O plate), and via coaxial cables to the two MPC modules – the six “A” (main) signals go to one MPC; the six “B” (diversity) to the other. The MPC outputs the low-noise-amplified signals via the SCCP backplane to the CIO where the signals are split and sent to the appropriate BBX2.
- A digital bus then routes the baseband signal through the BBX2, to the backplane, then on to the MCC24 slots.
- Digital TX antenna path signals originate at the MCC24s. Each output is routed from the MCC24 slot via the backplane appropriate BBX2.
- TX RF path signal originates from the BBX2, through the backplane to the CIO, through the CIO, and via multi-conductor coaxial cabling to the LPAs in the LPA shelf.

### SCCP Backplane Troubleshooting Procedure

The following table provides a standard procedure for troubleshooting problems that appear to be related to a defective SCCP backplane. The table is broken down into possible problems and steps which should be taken in an attempt to find the root cause.



#### IMPORTANT

It is important to note that all steps be followed before replacing ANY SCCP backplane.

Digital Control Problems

No GLI2 Control via LMF (all GLI2s)

<b>Table 6-15: No GLI2 Control via LMF (all GLI2s)</b>	
<b>Step</b>	<b>Action</b>
1	Check the Ethernet for proper connection, damage, shorts, or opens.
2	Verify SCCP backplane Shelf ID DIP switch is set correctly.
3	Visually check the master GLI2 connector (both board and backplane) for damage.
4	Replace the master GLI2 with a known good GLI2.

No GLI2 Control through Span Line Connection (All GLI2s)

<b>Table 6-16: No GLI2 Control through Span Line Connection (Both GLI2s)</b>	
<b>Step</b>	<b>Action</b>
1	Verify SCCP backplane Shelf ID DIP switch is set correctly.
2	Verify that the BTS and GLI2s are correctly configured in the OMCR/CBSC data base.
3	Visually check the master GLI2 connector (both board and backplane) for damage.
4	Replace the master GLI2 with a known good GLI2.
5	Check the span line inputs from the top of the frame to the master GLI2 for proper connection and damage.

<b>Table 6-17: MGLI2 Control Good – No Control over Co-located GLI2</b>	
<b>Step</b>	<b>Action</b>
1	Verify that the BTS and GLI2s are correctly configured in the OMCR CBSC data base.
2	Check the ethernet for proper connection, damage, shorts, or opens.
3	Visually check all GLI2 connectors (both board and backplane) for damage.
4	Replace the remaining GLI2 with a known good GLI2.

6

**No AMR Control (MGLI2 good)**

<b>Table 6-18: MGLI2 Control Good – No Control over AMR</b>	
<b>Step</b>	<b>Action</b>
1	Visually check the master GLI2 connector (both board and backplane) for damage.
2	Replace the master GLI2 with a known good GLI2.
3	Replace the AMR with a known good AMR.

**No BBX2 Control in the Shelf**

<b>Table 6-19: MGLI2 Control Good – No Control over Co-located GLI2s</b>	
<b>Step</b>	<b>Action</b>
1	Visually check all GLI2 connectors (both board and backplane) for damage.
2	Replace the remaining GLI2 with a known good GLI2.
3	Visually check BBX2 connectors (both board and backplane) for damage.
4	Replace the BBX2 with a known good BBX2.

**No (or Missing) Span Line Traffic**

<b>Table 6-20: BBX2 Control Good – No (or Missing) Span Line Traffic</b>	
<b>Step</b>	<b>Action</b>
1	Visually check all GLI2 connectors (both board and backplane) for damage.
2	Replace the remaining GLI2 with a known good GLI2.
3	Visually check all span line distribution (both connectors and cables) for damage.
4	If the problem seems to be limited to 1 BBX2, replace the BBX2 with a known good BBX2.

**No (or Missing) MCC24 Channel Elements**

<b>Table 6-21: No MCC24 Channel Elements</b>	
<b>Step</b>	<b>Action</b>
1	Verify CEs on a co-located MCC24 (MccType=2)
2	If the problem seems to be limited to 1 MCC24, replace the MCC24 with a known good MCC24. <ul style="list-style-type: none"> <li>– Check connectors (both board and backplane) for damage.</li> </ul>
3	If no CEs on any MCC24: <ul style="list-style-type: none"> <li>– Verify clock reference to CIO.</li> </ul>



## DC Power Problems



### WARNING

Potentially lethal voltage and current levels are routed to the BTS equipment. This test must be carried out with a second person present, acting in a safety role. Remove all rings, jewelry, and wrist watches prior to beginning this test.

### No DC Input Voltage to Power Supply Module

**Table 6-22: No DC Input Voltage to Power Supply Module**

Step	Action
1	<p>Verify DC power is applied to the BTS frame. Verify there are no breakers tripped.</p> <p><b>* IMPORTANT</b></p> <p>If a breaker has tripped, remove all modules from the applicable shelf supplied by the breaker and attempt to reset it.</p> <ul style="list-style-type: none"> <li>– If breaker trips again, there is probably a cable or breaker problem within the frame.</li> <li>– If breaker does not trip, there is probably a defective module or sub-assembly within the shelf.</li> </ul>
2	<p>Verify that the SCCP shelf breaker on the BTS frame breaker panel is functional.</p>
3	<p>Use a voltmeter to determine if the input voltage is being routed to the SCCP backplane by measuring the DC voltage level on the PWR_IN cable.</p> <ul style="list-style-type: none"> <li>– If the voltage is not present, there is probably a cable or breaker problem within the frame.</li> <li>– If the voltage is present at the connector, reconnect and measure the level at the “VCC” power feed clip on the distribution backplane. If the voltage is correct at the power clip, inspect the clip for damage.</li> </ul>
4	<p>If everything appears to be correct, visually inspect the power supply module connectors.</p>
5	<p>Replace the power supply module with a known good module.</p>
6	<p>If steps 1 through 4 fail to indicate a problem, the SCCP backplane failure (possibly an open trace) has occurred.</p>



### No DC Voltage (+5, +6.5, or +15 Volts) to a Specific GLI2, BBX2, or Switchboard

<b>Table 6-23: No DC Input Voltage to any SCCP Shelf Module</b>	
<b>Step</b>	<b>Action</b>
1	Verify steps outlined in Table 6-22 have been performed.
2	Inspect the defective board/module (both board and backplane) connector for damage.
3	Replace suspect board/module with known good board/module.

### TX and RX Signal Routing Problems

<b>Table 6-24: No DC Input Voltage to any SCCP Shelf Module</b>	
<b>Step</b>	<b>Action</b>
1	Inspect all Harting Cable connectors and back-plane connectors for damage in all the affected board slots.
2	Perform steps outlined in the RF path troubleshooting flowchart in this manual.

# RFDS – Fault Isolation

## Introduction

The RFDS is used to perform Pre-Calibration Verification and Post-Calibration Audits which limit-check the RFDS-generate and reported receive levels of every path from the RFDS through the directional coupler coupled paths. In the event of test failure, refer to the following tables.

## All tests fail

**Table 6-25:** RFDS Fault Isolation – All tests fail

Step	Action
1	Check the calibration equipment for proper operation by manually setting the signal generator output attenuator to the lowest output power setting and connecting the output port to the spectrum analyzer rf input port.
2	Set the signal generator output attenuator to $-90$ dBm, and switch on the rf output. Verify that the spectrum analyzer can receive the signal, indicate the correct signal strength, (accounting for the cable insertion loss), and the approximate frequency.
3	Visually inspect RF cabling. Make sure each directional coupler forward and reflected port connects to the RFDS antenna select unit on the RFDS.
4	Check the wiring against the site documentation wiring diagram or the <i>BTS Site Installation</i> manual.
5	Verify RGLI and TSU have been downloaded.
6	Check to see that all RFDS boards show green on the front panel indicators. Visually check (both board and backplane) for damage.
7	Replace any boards that do not show green with known good boards one at a time in the following order. Re-test after each is replaced. <ul style="list-style-type: none"><li>– RFDS ASU board.</li><li>– RFDS Transceiver board.</li></ul>

## All RX and TX paths fail

If every receive or transmit path fails, the problem most likely lies with the rf converter board or the transceiver board. Refer to the following table for fault isolation procedures.

**Table 6-26:** RFDS Fault Isolation – All RX and TX paths fail

Step	Action
1	Visually check the master RF converter board (both board and backplane) for damage.
2	Replace the RF converter board with a known good RF converter board.
3	Visually check RXCVR TSU (both board and backplane) for damage.
4	Replace the TSU with a known good TSU.

---

## RFDS – Fault Isolation – continued

### All tests fail on a single antenna

If all path failures are on one antenna port, forward and/or reflected, make the following checks.

<b>Table 6-27: RFDS Fault Isolation – All tests fail on single antenna path</b>	
<b>Step</b>	<b>Action</b>
1	Visually inspect the site interface cabinet internal cabling to the suspect directional coupler antenna port.
2	Verify the forward and reflected ports connect to the correct RFDS antenna select unit positions on the RFDS backplane. Refer to the installation manual for details.
3	Visually check ASU connectors (both board and backplane) for damage.
4	Replace the ASU with a known good ASU.
5	Replace the RF cables between the affected directional coupler and RFDS. <b>NOTE</b> Externally route the cable to bypass suspect segment.

---

# Module Front Panel LED Indicators and Connectors

## Module Status Indicators

Each of the non-passive plug-in modules has a bi-color (green & red) LED status indicator located on the module front panel. The indicator is labeled PWR/ALM. If both colors are turned on, the indicator is yellow.

Each plug-in module, except for the fan module, has its own alarm (fault) detection circuitry that controls the state of the PWR/ALM LED.

The fan TACH signal of each fan module is monitored by the AMR. Based on the status of this signal the AMR controls the state of the PWR/ALM LED on the fan module.

## LED Status Combinations for All Modules (except GLI2, CSM, BBX2, MCC24, MCC8E)

### PWR/ALM LED

The following list describes the states of the module status indicator.

- Solid GREEN – module operating in a normal (fault free) condition.
- Solid RED – module is operating in a fault (alarm) condition due to electrical hardware failure.

Note that a fault (alarm) indication may or may not be due to a complete module failure and normal service may or may not be reduced or interrupted.

## DC/DC Converter LED Status Combinations

The PWR CNVTR has its own alarm (fault) detection circuitry that controls the state of the PWR/ALM LED.

### PWR/ALM LED

The following list describes the states of the bi-color LED.

- Solid GREEN – module operating in a normal (fault free) condition.
- Solid RED – module is operating in a fault (alarm) condition due to electrical hardware problem.

## CSM LED Status Combinations

### PWR/ALM LED

The CSMs include on-board alarm detection. Hardware and software/firmware alarms are indicated via the front panel indicators.

After the memory tests, the CSM loads OOS-RAM code from the Flash EPROM, if available. If not available, the OOS-ROM code is loaded from the Flash EPROM.

- Solid GREEN – module is INS\_ACT or INS\_STBY no alarm.
- Solid RED – Initial power up or module is operating in a fault (alarm) condition.
- Slowly Flashing GREEN – OOS\_ROM no alarm.
- Long RED/Short GREEN – OOS\_ROM alarm.
- Rapidly Flashing GREEN – OOS\_RAM no alarm or INS\_ACT in DUMB mode.
- Short RED/Short GREEN – OOS\_RAM alarm.
- Long GREEN/Short RED – INS\_ACT or INS\_STBY alarm.
- Off – no DC power or on-board fuse is open.
- Solid YELLOW – After a reset, the CSMs begin to boot. During SRAM test and Flash EPROM code check, the LED is yellow. (If SRAM or Flash EPROM fail, the LED changes to a solid RED and the CSM attempts to reboot.)

**Figure 6-1:** CSM Front Panel Indicators & Monitor Ports

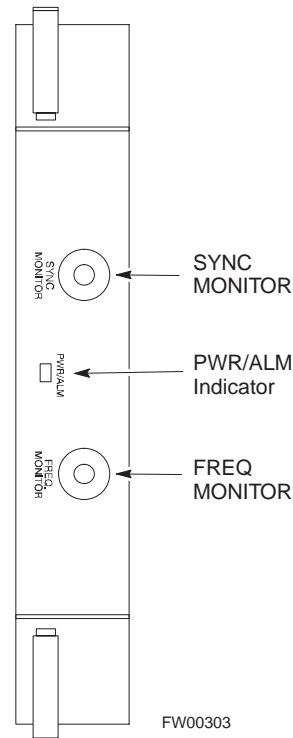

. . . continued on next page

### **FREQ Monitor Connector**

A test port provided at the CSM front panel via a BNC receptacle allows monitoring of the 19.6608 MHz clock generated by the CSM. When both CSM 1 and CSM 2 are in an in-service (INS) condition, the CSM 2 clock signal frequency is the same as that output by CSM 1.

The clock is a sine wave signal with a minimum amplitude of +2 dBm (800 mVpp) into a 50  $\Omega$  load connected to this port.

### **SYNC Monitor Connector**

A test port provided at the CSM front panel via a BNC receptacle allows monitoring of the “Even Second Tick” reference signal generated by the CSMs.

At this port, the reference signal is a TTL active high signal with a pulse width of 153 nanoseconds.

**MMI Connector** – Only accessible behind front panel. The RS-232 MMI port connector is intended to be used primarily in the development or factory environment, but may be used in the field for debug/maintenance purposes.

### GLI2 LED Status Combinations

The GLI2 module has indicators, controls and connectors as described below and shown in Figure 6-2.

The indicators and controls consist of:

- Four LEDs
- One pushbutton

#### ACTIVE LED

Solid GREEN – GLI2 is active. This means that the GLI2 has shelf control and is providing control of the digital interfaces.

Off – GLI2 is not active (i.e., Standby). The mate GLI2 should be active.

#### MASTER LED

- Solid GREEN – GLI2 is Master (sometimes referred to as MGLI2).
- Off – GLI2 is non-master (i.e., Slave).

#### ALARM LED

- Solid RED – GLI2 is in a fault condition or in reset.
- While in reset transition, STATUS LED is OFF while GLI2 is performing ROM boot (about 12 seconds for normal boot).
- While in reset transition, STATUS LED is ON while GLI2 is performing RAM boot (about 4 seconds for normal boot).
- Off – No Alarm.

#### STATUS LED

- Flashing GREEN– GLI2 is in service (INS), in a stable operating condition.
- On – GLI2 is in OOS RAM state operating downloaded code.
- Off – GLI2 is in OOS ROM state operating boot code.

#### SPANS LED

- Solid GREEN – Span line is connected and operating.
- Solid RED – Span line is disconnected or a fault condition exists.

**GLI2 Pushbuttons and Connectors**

**RESET Pushbutton** – Depressing the RESET pushbutton causes a partial reset of the CPU and a reset of all board devices. GLI2 will be placed in the OOS\_ROM state

**MMI Connector** – The RS-232MMI port connector is intended to be used primarily in the development or factory environment but may be used in the field for debug/maintenance purposes.

**Figure 6-2:** GLI2 Front Panel Operating Indicators

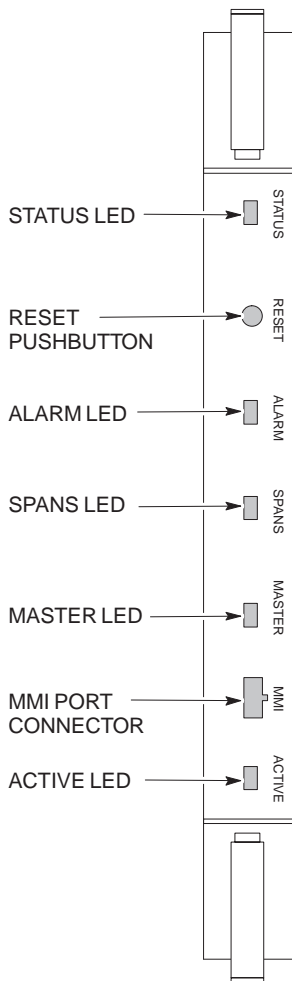

LED	OPERATING STATUS
STATUS	OFF – operating normally ON – briefly during power-up when the Alarm LED turns OFF. SLOW GREEN – when the GLI2 is INS (in-service)
RESET	All functions on the GLI2 are reset when pressing and releasing the switch.
ALARM	OFF – operating normally ON – briefly during power-up when the Alarm LED turns OFF. SLOW GREEN – when the GLI2 is INS (in-service)
SPANS	OFF – card is powered down, in initialization, or in standby GREEN – operating normally YELLOW – one or more of the equipped initialized spans is receiving a remote alarm indication signal from the far end RED – one or more of the equipped initialized spans is in an alarm state
MASTER	The pair of GLI2 cards include a redundant status. The card in the top shelf is designated by hardware as the active card; the card in the bottom shelf is in the standby mode. ON – operating normally in active card OFF – operating normally in standby card
MMI PORT CONNECTOR	An RS-232, serial, asynchronous communications link for use as an MMI port. This port supports 300 baud, up to a maximum of 115,200 baud communications.
ACTIVE	Shows the operating status of the redundant cards. The redundant card toggles automatically if the active card is removed or fails ON – active card operating normally OFF – standby card operating normally

FW00225



### BBX2 LED Status Combinations

#### PWR/ALM LED

The BBX module has its own alarm (fault) detection circuitry that controls the state of the PWR/ALM LED.

The following list describes the states of the bi-color LED:

- Solid GREEN – INS\_ACT no alarm
- Solid RED Red – initializing or power-up alarm
- Slowly Flashing GREEN – OOS\_ROM no alarm
- Long RED/Short GREEN – OOS\_ROM alarm
- Rapidly Flashing GREEN – OOS\_RAM no alarm
- Short RED/Short GREEN – OOS\_RAM alarm
- Long GREEN/Short RED – INS\_ACT alarm

### MCC24 LED Status Combinations

The MCC24 module has LED indicators and connectors as described below. See Figure 6-3. Note that the figure does not show the connectors as they are concealed by the removable lens.

The LED indicators and their states are as follows:

#### PWR/ALM LED

- RED – fault on module

#### ACTIVE LED

- Off – module is inactive, off-line, or not processing traffic.
- Slowly Flashing GREEN – OOS\_ROM no alarm.
- Rapidly Flashing Green – OOS\_RAM no alarm.
- Solid GREEN – module is INS\_ACT, on-line, processing traffic.

#### PWR/ALM and ACTIVE LEDs

- Solid RED – module is powered but is in reset or the BCP is inactive.

#### MMI Connectors

- The RS–232 MMI port connector (four-pin) is intended to be used primarily in the development or factory environment but may be used in the field for debugging purposes.
- The RJ–11 ethernet port connector (eight-pin) is intended to be used primarily in the development environment but may be used in the field for high data rate debugging purposes.

. . . continued on next page

Figure 6-3: MCC24 Front Panel LEDs and LED Indicators

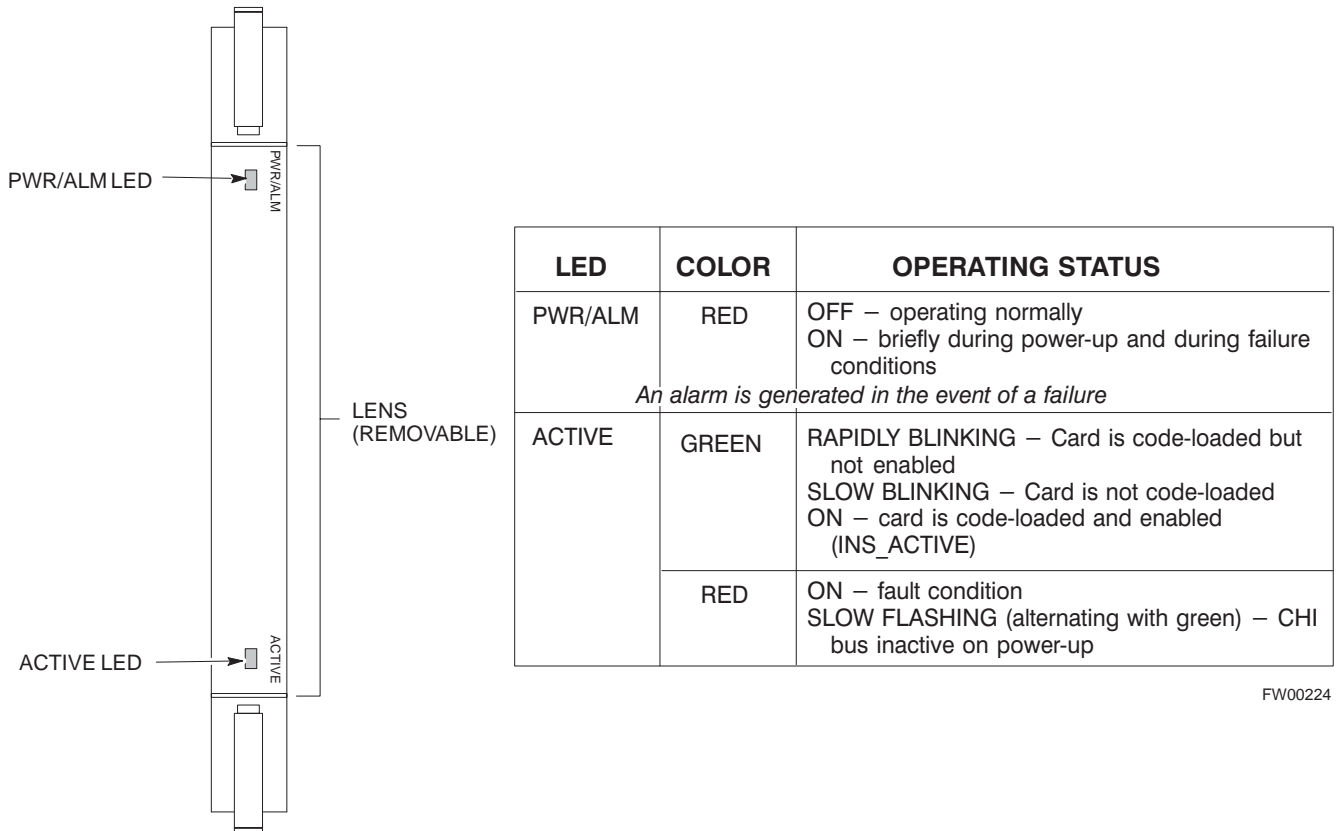

FW00224

6

LPA Shelf LED Status Combinations

LPA Module LED

Each LPA module is provided with a bi-color LED on the ETIB module next to the MMI connector. Interpret this LED as follows:

- GREEN — LPA module is active and is reporting no alarms (Normal condition).
- Flashing GREEN/RED — LPA module is active but is reporting an low input power condition. If no BBX is keyed, this is normal and does not constitute a failure.
- Flashing RED — LPA is in alarm.

## Basic Troubleshooting – Span Control Link

### Span Problems (No Control Link)

**Table 6-28:** Troubleshoot Control Link Failure

✓ Step	Action
1	Connect the CDMA LMF computer to the MMI port on the applicable MGLI2/GLI2 as shown in Figure 6-4.
2	Start an MMI communication session with the applicable MGLI2/GLI2 by using the Windows desktop shortcut icon (refer to Table 3-11).
3	Once the connection window opens, press the CDMA LMF computer Enter key until the GLI2> prompt is obtained.
4	<p>At the GLI2&gt; prompt, enter:</p> <p><b>span view &lt;cr&gt;</b></p> <p>The system will respond with a display similar to the following framing format and line code configuration example:</p> <pre> COMMAND ACCEPTED:  span view  The parameter in NVM is set to T1_2.        56K AMI                               64K B8ZS       Span Type-T1-3                         Span Type-T1-2       Span Rate=56                           Span Rate=64       Span A Type-T1 long haul                Span A Type-T1 long haul       Span A Type-T1 long haul                Span A Type-T1 long haul       Lapd slot for Span A=0                  Lapd slot for Span A=0       Lapd slot for Span B=0                  Lapd slot for Span B=0           </pre>
5	The span configurations loaded in the GLI must match those in the OMCR/CBSC database for the BTS. If they do not, proceed to Table 6-29.
6	Repeat steps 1 through 5 for all remaining GLIs.
7	<p>If the span settings are correct, verify the edlc parameters using the <code>show</code> command.</p> <p>Any alarm conditions indicate that the span is not operating correctly.</p> <ul style="list-style-type: none"> <li>• Try looping back the span line from the DSX panel back to the MM, and verify that the looped signal is good.</li> <li>• Listen for control tone on the appropriate timeslot from the Base Site and MM.</li> </ul>
8	Exit the GLI MMI session and HyperTerminal connection by selecting <b>File</b> from the connection window menu bar, and then <b>Exit</b> from the dropdown menu.
9	If no TCHs in groomed MCCs (or in whole SCCP shelf) can process calls, verify that the ISB cabling is correct and that ISB A and ISB B cables are not swapped.

Figure 6-4: MGLI/GLI Board MMI Connection Detail

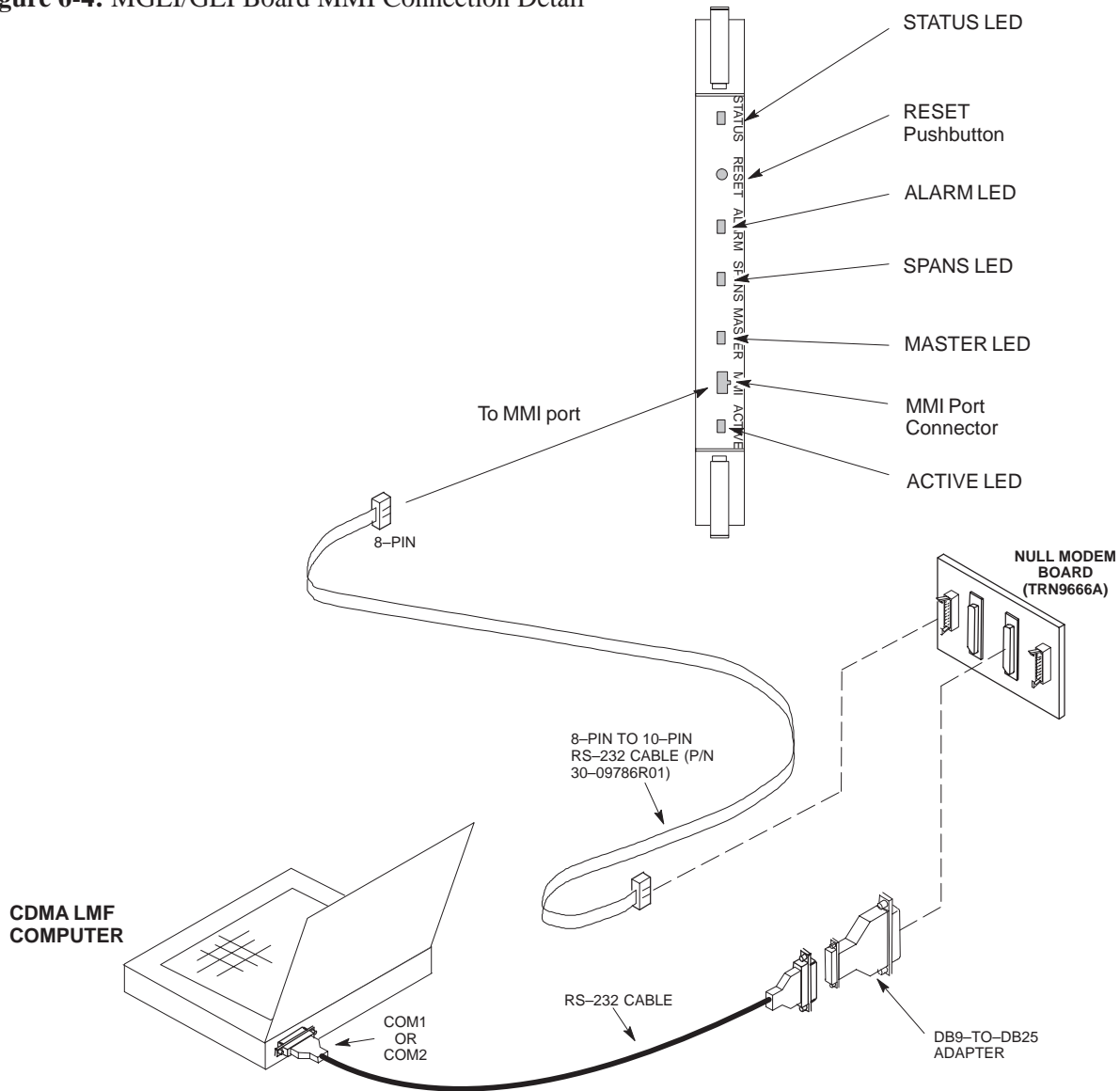

6

Set BTS Site Span Configuration



**IMPORTANT**

Perform the following procedure *ONLY* if span configurations loaded in the MGLI2/GLI2s do not match those in the OMCR/CBSC data base, *AND ONLY* when the exact configuration data is available. Loading incorrect span configuration data will render the site inoperable.

## Basic Troubleshooting – Span Control Link – continued

**Table 6-29: Set BTS Span Parameter Configuration**

✓ Step	Action																				
1	If not previously done, connect the CDMA LMF computer to the MMI port on the applicable MGLI2/GLI2 as shown in Figure 6-4.																				
2	If there is no MMI communication session in progress with the applicable MGLI2/GLI2, initiate one by using the Windows desktop shortcut icon (refer to Table 3-11).																				
3	<p>At the GLI2&gt; prompt, enter:</p> <p><b>span set</b> &lt;option&gt; &lt;cr&gt;</p> <p><i>Where:</i> option = the framing format option from the list below:</p> <table border="0"> <thead> <tr> <th style="text-align: left;"><i>Option</i></th> <th style="text-align: left;"><i>Description</i></th> </tr> </thead> <tbody> <tr> <td>E1_1</td> <td>E1_1 – E1 HDB3 CRC4 no TS16</td> </tr> <tr> <td>E1_2</td> <td>E1_2 – E1 HDB3 no CRC4 no TS16</td> </tr> <tr> <td>E1_3</td> <td>E1_3 – E1 HDB3 CRC4 no TS16</td> </tr> <tr> <td>E1_4</td> <td>E1_3 – E1 HDB3 no CRC4 TS16</td> </tr> <tr> <td>T1_1</td> <td>T1_1 – D4 AMI NO ZCS</td> </tr> <tr> <td>T1_2</td> <td>T1_2 – ESF B8ZS</td> </tr> <tr> <td>T1_3</td> <td>T1_3 – D4 AMI ZCS</td> </tr> <tr> <td>J1_1</td> <td>J1_1 – ESF B8ZS (Japan) – (Default)</td> </tr> <tr> <td>J1_2</td> <td>J1_2 – ESF B8ZS</td> </tr> </tbody> </table> <p>Example – to set span to “E1_3”:</p> <p><b>span set E1_3</b> &lt;cr&gt;</p>	<i>Option</i>	<i>Description</i>	E1_1	E1_1 – E1 HDB3 CRC4 no TS16	E1_2	E1_2 – E1 HDB3 no CRC4 no TS16	E1_3	E1_3 – E1 HDB3 CRC4 no TS16	E1_4	E1_3 – E1 HDB3 no CRC4 TS16	T1_1	T1_1 – D4 AMI NO ZCS	T1_2	T1_2 – ESF B8ZS	T1_3	T1_3 – D4 AMI ZCS	J1_1	J1_1 – ESF B8ZS (Japan) – (Default)	J1_2	J1_2 – ESF B8ZS
<i>Option</i>	<i>Description</i>																				
E1_1	E1_1 – E1 HDB3 CRC4 no TS16																				
E1_2	E1_2 – E1 HDB3 no CRC4 no TS16																				
E1_3	E1_3 – E1 HDB3 CRC4 no TS16																				
E1_4	E1_3 – E1 HDB3 no CRC4 TS16																				
T1_1	T1_1 – D4 AMI NO ZCS																				
T1_2	T1_2 – ESF B8ZS																				
T1_3	T1_3 – D4 AMI ZCS																				
J1_1	J1_1 – ESF B8ZS (Japan) – (Default)																				
J1_2	J1_2 – ESF B8ZS																				
4	Observe that an acknowledgement is displayed.																				
5	Enter the following MMI command to display the current MGLI2/GLI2 span rate: <b>config ni linkspeed</b> <cr>																				
6	<p>Observe that a response is displayed similar to the following output example:</p> <pre>Option      Linkspeed Option   56        56k (default for T1_1 and T1_3 systems)   64        64k (default for all other span configurations) default    Use the default speed appropriate for the span type  The linkspeed parameter in flash is set to use 64k. Currently the link is running at 64. The actual rate is 0.</pre>																				
	<p><b>* IMPORTANT</b></p> <p>After executing the <b>span set</b> and <b>config ni linkspeed</b> commands, the affected MGLI2/GLI2 board <i>MUST</i> be reset and reloaded for changes to take effect.</p> <p>Although defaults are shown, <i>always</i> consult site specific documentation for span type and rate used at the site.</p>																				

... continued on next page

---

## Basic Troubleshooting – Span Control Link – continued

**Table 6-29:** Set BTS Span Parameter Configuration

✓	Step	Action
	7	Press the RESET button on the MGLI2/GLI2 for changes to take effect.
	8	Return to step 6 of Table 6-28.

**Appendix A: Data Sheets**  
**Appendix Content**

---

Appendix A: Optimization (Pre-ATP) Data Sheets .....	A-1
Verification of Test Equipment Used .....	A-1
Site Checklist .....	A-2
Preliminary Operations .....	A-2
Pre-Power and Initial Power Tests .....	A-3
General Optimization Checklist .....	A-4
GPS Receiver Operation .....	A-5
LFR Receiver Operation .....	A-6
LPA IM Reduction .....	A-7
TX Bay Level Offset / Power Output Verification for 3-Sector Configurations .....	A-8
TX Antenna VSWR .....	A-10
RX Antenna VSWR .....	A-11
Alarm Verification .....	A-11
Appendix A: Site Serial Number Check List .....	A-13
SCCP Shelf .....	A-13
LPAs .....	A-14







**Appendix A: Optimization (Pre-ATP) Data Sheets – continued**

**Site Checklist**

<b>Table A-2: Site Checklist</b>			
<b>OK</b>	<b>Parameter</b>	<b>Specification</b>	<b>Comments</b>
<input type="checkbox"/>	Deliveries	Per established procedures	
<input type="checkbox"/>	Floor Plan	Verified	
<input type="checkbox"/>	Inter Frame Cables:		
<input type="checkbox"/>	Ethernet	Per procedure	
<input type="checkbox"/>	Frame Ground	Per procedure	
<input type="checkbox"/>	Power	Per procedure	
<input type="checkbox"/>	Factory Data:		
<input type="checkbox"/>	BBX2	Per procedure	
<input type="checkbox"/>	Test Panel	Per procedure	
<input type="checkbox"/>	RFDS	Per procedure	
<input type="checkbox"/>	Site Temperature		
<input type="checkbox"/>	Dress Covers/Brackets		

**Preliminary Operations**

<b>Table A-3: Preliminary Operations</b>			
<b>OK</b>	<b>Parameter</b>	<b>Specification</b>	<b>Comments</b>
<input type="checkbox"/>	Shelf ID Dip Switches	Per site equipage	
<input type="checkbox"/>	Ethernet LAN verification	Verified per procedure	

Comments: \_\_\_\_\_

**Pre-Power and Initial Power Tests**

Table A3a: Pre-power Checklist			
OK	Parameter	Specification	Comments
<input type="checkbox"/>	Pre-power-up tests	Verify power supply output voltage at the top of each BTS frame is within specifications	
<input type="checkbox"/>	Internal Cables:		
<input type="checkbox"/>	ISB (all cages)	verified	
<input type="checkbox"/>	CSM (all cages)	verified	
<input type="checkbox"/>	Power (all cages)	verified	
	Ethernet Connectors		
<input type="checkbox"/>	LAN A ohms	verified	
<input type="checkbox"/>	LAN B ohms	verified	
<input type="checkbox"/>	LAN A shield	isolated	
<input type="checkbox"/>	LAN B shield	isolated	
<input type="checkbox"/>	Ethernet Boots	installed	
<input type="checkbox"/>	Air Impedance Cage (single cage)	installed	
<input type="checkbox"/>	Initial power-up tests	Verify power supply output voltage at the top of each BTS frame is within specifications:	

Comments: \_\_\_\_\_

**Appendix A: Optimization (Pre-ATP) Data Sheets – continued**

**General Optimization Checklist**

<b>Table A3b: Pre-power Checklist</b>			
<b>OK</b>	<b>Parameter</b>	<b>Specification</b>	<b>Comments</b>
<input type="checkbox"/>	LEDs	illuminated	
<input type="checkbox"/>	Frame fans	operational	
	<b>LMF to BTS Connection</b>		
<input type="checkbox"/>	Preparing the LMF	per procedure	
<input type="checkbox"/>	Log into the LMF PC	per procedure	
<input type="checkbox"/>	Create site specific BTS directory	per procedure	
<input type="checkbox"/>	Download device loads	per procedure	
<input type="checkbox"/>	Ping LAN A	per procedure	
<input type="checkbox"/>	Ping LAN B	per procedure	
<input type="checkbox"/>	Download/Enable MGLI2s	per procedure	
<input type="checkbox"/>	Download/Enable GLI2s	per procedure	
<input type="checkbox"/>	Set Site Span Configuration	per procedure	
<input type="checkbox"/>	Download CSMs	per procedure	
<input type="checkbox"/>	Enable CSMs	per procedure	
<input type="checkbox"/>	Enable CSMs	per procedure	
<input type="checkbox"/>	Download/Enable MCC24s	per procedure	
<input type="checkbox"/>	Download BBX2s	per procedure	
<input type="checkbox"/>	Download TSU (in RFDS) Program TSU NAM	per procedure	
<input type="checkbox"/>	Test Set Calibration	per procedure	

Comments: \_\_\_\_\_

GPS Receiver Operation

Table A-4: GPS Receiver Operation			
OK	Parameter	Specification	Comments
<input type="checkbox"/>	GPS Receiver Control Task State: <b>tracking satellites</b>	Verify parameter	
<input type="checkbox"/>	Initial Position Accuracy:	Verify Estimated or Surveyed	
<input type="checkbox"/>	Current Position: <b>lat</b> <b>lon</b> <b>height</b>	RECORD in msec and cm also convert to deg min sec	
<input type="checkbox"/>	Current Position: satellites tracked Estimated: <b>(&gt;4) satellites tracked,(&gt;4) satellites visible</b> Surveyed: <b>(≥1) satellite tracked,(&gt;4) satellites visible</b>	Verify parameter as appropriate:	
<input type="checkbox"/>	GPS Receiver Status:Current Dilution of Precision (PDOP or HDOP): <b>(&lt;30)</b>	Verify parameter	
<input type="checkbox"/>	Current reference source: <b>Number: 0; Status: Good; Valid: Yes</b>	Verify parameter	

Comments: \_\_\_\_\_

**Appendix A: Optimization (Pre-ATP) Data Sheets – continued**

**LFR Receiver Operation**

<b>Table A-5: LFR Receiver Operation</b>			
<b>OK</b>	<b>Parameter</b>	<b>Specification</b>	<b>Comments</b>
<input type="checkbox"/>	Station call letters M X Y Z assignment.	as specified in site documentation	
<input type="checkbox"/>	SN ratio is > 8 dB		
<input type="checkbox"/>	LFR Task State: 1fr <b>locked to station xxxx</b>	Verify parameter	
<input type="checkbox"/>	Current reference source: <b>Number: 1; Status: Good; Valid: Yes</b>	Verify parameter	

Comments: \_\_\_\_\_

LPA IM Reduction

Table A-6: LPA IM Reduction					
OK	Parameter			Specification	Comments
	LPA #	CARRIER			
		2:1 3-Sector	BP 3-Sector		
<input type="checkbox"/>	1A	C1	C1	No Alarms	
<input type="checkbox"/>	1B	C1	C1	No Alarms	
<input type="checkbox"/>	1C	C1	C1	No Alarms	
<input type="checkbox"/>	1D	C1	C1	No Alarms	
<input type="checkbox"/>	3A	C2	C2	No Alarms	
<input type="checkbox"/>	3B	C2	C2	No Alarms	
<input type="checkbox"/>	3C	C2	C2	No Alarms	
<input type="checkbox"/>	3D	C2	C2	No Alarms	

Comments: \_\_\_\_\_

**Appendix A: Optimization (Pre-ATP) Data Sheets** – continued

**TX Bay Level Offset / Power  
Output Verification for  
3-Sector Configurations**

**1-Carrier  
2-Carrier Non-adjacent Channels**

**Table A-7: TX BLO Calibration (3-Sector: 1-Carrier, 2-Carrier and 4-Carrier Non-adjacent Channels)**

OK	Parameter	Specification	Comments
<input type="checkbox"/>	Calibrate carrier 1	TX Bay Level Offset = 37 dB ( $\pm 4$ dB) prior to calibration	BBX2-1, ANT-1 = ___ dB BBX2-r, ANT-1 = ___ dB
<input type="checkbox"/>			BBX2-2, ANT-2 = ___ dB BBX2-r, ANT-2 = ___ dB
<input type="checkbox"/>			BBX2-3, ANT-3 = ___ dB BBX2-r, ANT-3 = ___ dB
<input type="checkbox"/>	Calibrate carrier 2	TX Bay Level Offset = 37 dB ( $\pm 4$ dB) prior to calibration	BBX2-7, ANT-1 = ___ dB BBX2-r, ANT-1 = ___ dB
<input type="checkbox"/>			BBX2-8, ANT-2 = ___ dB BBX2-r, ANT-2 = ___ dB
<input type="checkbox"/>			BBX2-9, ANT-3 = ___ dB BBX2-r, ANT-3 = ___ dB
<input type="checkbox"/>	Calibration Audit carrier 1	0 dB ( $\pm 0.5$ dB) for gain set resolution post calibration	BBX2-1, ANT-1 = ___ dB BBX2-r, ANT-1 = ___ dB
<input type="checkbox"/>			BBX2-2, ANT-2 = ___ dB BBX2-r, ANT-2 = ___ dB
<input type="checkbox"/>			BBX2-3, ANT-3 = ___ dB BBX2-r, ANT-3 = ___ dB
<input type="checkbox"/>	Calibration Audit carrier 2	0 dB ( $\pm 0.5$ dB) for gain set resolution post calibration	BBX2-7, ANT-1 = ___ dB BBX2-r, ANT-1 = ___ dB
<input type="checkbox"/>			BBX2-8, ANT-2 = ___ dB BBX2-r, ANT-2 = ___ dB
<input type="checkbox"/>			BBX2-9, ANT-3 = ___ dB BBX2-r, ANT-3 = ___ dB

Comments: \_\_\_\_\_



2-Carrier Adjacent Channel

Table A-8: TX Bay Level Offset Calibration (3-Sector: 2-Carrier Adjacent Channels)			
OK	Parameter	Specification	Comments
<input type="checkbox"/>	Calibrate carrier 1	TX Bay Level Offset = 42 dB (typical), 38 dB (minimum) prior to calibration	BBX2-1, ANT-1 = ___ dB BBX2-r, ANT-1 = ___ dB
<input type="checkbox"/>			BBX2-2, ANT-2 = ___ dB BBX2-r, ANT-2 = ___ dB
<input type="checkbox"/>			BBX2-3, ANT-3 = ___ dB BBX2-r, ANT-3 = ___ dB
<input type="checkbox"/>	Calibrate carrier 2	TX Bay Level Offset = 42 dB (typical), 38 dB (minimum) prior to calibration	BBX2-7, ANT-4 = ___ dB BBX2-r, ANT-4 = ___ dB
<input type="checkbox"/>			BBX2-8, ANT-5 = ___ dB BBX2-r, ANT-5 = ___ dB
<input type="checkbox"/>			BBX2-9, ANT-6 = ___ dB BBX2-r, ANT-6 = ___ dB
<input type="checkbox"/>	Calibration Audit carrier 1	0 dB ( $\pm 0.5$ dB) for gain set resolution post calibration	BBX2-1, ANT-1 = ___ dB BBX2-r, ANT-1 = ___ dB
<input type="checkbox"/>			BBX2-2, ANT-2 = ___ dB BBX2-r, ANT-2 = ___ dB
<input type="checkbox"/>			BBX2-3, ANT-3 = ___ dB BBX2-r, ANT-3 = ___ dB
<input type="checkbox"/>	Calibration Audit carrier 2	0 dB ( $\pm 0.5$ dB) for gain set resolution post calibration	BBX2-7, ANT-4 = ___ dB BBX2-r, ANT-4 = ___ dB
<input type="checkbox"/>			BBX2-8, ANT-5 = ___ dB BBX2-r, ANT-5 = ___ dB
<input type="checkbox"/>			BBX2-9, ANT-6 = ___ dB BBX2-r, ANT-6 = ___ dB

Comments: \_\_\_\_\_

\_\_\_\_\_

**Appendix A: Optimization (Pre-ATP) Data Sheets** – continued

**TX Antenna VSWR**

<b>Table A-9: TX Antenna VSWR</b>			
<b>OK</b>	<b>Parameter</b>	<b>Specification</b>	<b>Data</b>
<input type="checkbox"/>	VSWR – Antenna A1	< (1.5 : 1)	
<input type="checkbox"/>	VSWR – Antenna A2	< (1.5 : 1)	
<input type="checkbox"/>	VSWR – Antenna A3	< (1.5 : 1)	
<input type="checkbox"/>	VSWR – Antenna B4	< (1.5 : 1)	
<input type="checkbox"/>	VSWR – Antenna B5	< (1.5 : 1)	
<input type="checkbox"/>	VSWR – Antenna B6	< (1.5 : 1)	

Comments: \_\_\_\_\_  
 \_\_\_\_\_

**RX Antenna VSWR**

<b>Table A-10: RX Antenna VSWR</b>			
<b>OK</b>	<b>Parameter</b>	<b>Specification</b>	<b>Data</b>
<input type="checkbox"/>	VSWR – Antenna A1	< (1.5 : 1)	
<input type="checkbox"/>	VSWR – Antenna A2	< (1.5 : 1)	
<input type="checkbox"/>	VSWR – Antenna A3	< (1.5 : 1)	
<input type="checkbox"/>	VSWR – Antenna B4	< (1.5 : 1)	
<input type="checkbox"/>	VSWR – Antenna B5	< (1.5 : 1)	
<input type="checkbox"/>	VSWR – Antenna BXC6	< (1.5 : 1)	

Comments: \_\_\_\_\_

**Alarm Verification**

<b>Table A-11: CDI Alarm Input Verification</b>			
<b>OK</b>	<b>Parameter</b>	<b>Specification</b>	<b>Data</b>
<input type="checkbox"/>	Verify CDI alarm input operation per Table 3-1.	BTS Relay #XX – Contact Alarm Sets/Clears	

Comments: \_\_\_\_\_





---

**Appendix A: Site Serial Number Check List** – continued

**LPA**s

LPA 1A	_____
LPA 1B	_____
LPA 1C	_____
LPA 1D	_____
LPA 3A	_____
LPA 3B	_____
LPA 3C	_____
LPA 3D	_____

# Appendix B: FRU Optimization/ATP Test Matrix



## Appendix Content

---

Appendix B: FRU Optimization/ATP Test Matrix .....	B-1
Usage & Background .....	B-1
Detailed Optimization/ATP Test Matrix .....	B-2





# Appendix B: FRU Optimization/ATP Test Matrix

## Usage & Background

Periodic maintenance of a site may also may mandate re-optimization of specific portions of the site. An outline of some basic guidelines is included in the following tables.



### IMPORTANT

Re-optimization steps listed for any assembly detailed in the tables below must be performed *anytime* a RF cable associated with it is replaced.

## BTS Frame

Table B-1: When RF Optimization Is required on the BTS	
Item Replaced	Optimize:
SCCP Shelf	All sector TX and RX paths to all Combined CDMA Channel Processor (SCCP) shelves.
Multicoupler/Preselector Card	The three or six affected sector RX paths for the SCCP shelf in the BTS frames.
Preselector I/O	All sector RX paths.
BBX2 board	RX and TX paths of the affected SCCP shelf / BBX2 board.
CIO Card	All RX and TX paths of the affected CDMA carrier.
Any LPA Module	The affected sector TX path.

## Ancillary Frame

Item Replaced	Optimize:
Directional Coupler	All affected sector RX and TX paths to all BTS frame shelves.
Site filter	All affected RX sector paths in all shelves in all BTS frames.
Any RFDS component or TSU.	The RFDS calibration RX & TX paths (MONFWD/GENFWD).



**Inter-frame Cabling**

Optimization must be performed after the replacement of any RF cabling between BTS frames.

<b>Table B-2: When to Optimize Inter-frame Cabling</b>	
<b>Item Replaced</b>	<b>Optimize:</b>
Expansion frame to BTS frame (RX) cables	The affected sector/antenna RX paths.
BTS frame to expansion frame (TX) cables	The affected sector/antenna TX paths.

**Detailed Optimization/ATP Test Matrix**

Table B-3 outlines in more detail the tests that would need to be performed if one of the BTS components were to fail and be replaced. It is also assumed that all modules are placed OOS-ROM via the LMF until full redundancy of all applicable modules is implemented.

The following guidelines should also be noted when using this table.



**IMPORTANT**

Not every procedure required to bring the site back on line is indicated in Table B-3. It is meant to be used as a guideline ONLY. The table assumes that the user is familiar enough with the BTS Optimization/ATP procedure to understand which test equipment set ups, calibrations, and BTS site preparation will be required before performing the Table # procedures referenced.

Various passive BTS components (such as the TX and RX directional couplers, Preselector IO, CIO; etc.) only call for a TX or RX calibration audit to be performed in lieu of a full path calibration. If the RX or TX path calibration audit fails, the entire RF path calibration will need to be repeated. If the RF path calibration fails, further troubleshooting is warranted.

Whenever any SCCP BACKPLANE is replaced, it is assumed that only power to the SCCP shelf being replaced is turned off via the breaker supplying that shelf.

**NOTE**

If any significant change in signal level results from any component being replaced in the RX or TX signal flow paths, it would be identified by re-running the RX and TX calibration audit command.

When the CIO is replaced, the SCCP shelf remains powered up. The BBX2 boards may need to be removed, then re-installed into their

---

## Appendix B: FRU Optimization/ATP Test Matrix – continued

original slots, and re-downloaded (code and BLO data). RX and TX calibration audits should then be performed.



**Appendix B: FRU Optimization/ATP Test Matrix – continued**

**B**

**Table B-3: SC 4812ET BTS Optimization and ATP Test Matrix**

Doc Tbl #	Description	Directional Coupler (RX)	Directional Coupler (TX)	RX Filter	RX Cables	TX Cables	Multicoupler/Preselector	CIO	SCCP Backplane	BBX2	MCC24	CSM	LFR/HSO	GPS	GLI2	LPA	LPA Filter Bandpass	Power Converters (See Note)	SWITCH CARD	LPA Combiner Filter 2:1
Table 2-1	Initial Boards/Modules Install, Preliminary Operations, CDF Site Equipage; etc.	•	•	•	•	•	•	•	•	•	•	•	•	•	•	•	•	•	•	•
Table 2-6	Initial Power-up			•					•											
NO TAG/ NO TAG	Start LMF								•	•	•	•			•				•	
NO TAG/ NO TAG	Download Code								•						•					
Table 3-16	Enable CSMs								•			•								
Table 3-19	GPS Initialization / Verification								•			•	•							
Table 3-20	LFR Initialization / Verification								•				•							
Table 3-33	TX Path Calibration								•	•									•	
Table 3-34	Download Offsets to BBX2						•		•	•										
Table 3-35	TX Path Calibration Audit	•				•		•	•	•						•	•		•	•
Table 4-1	Spectral Purity TX Mask								•	•						•	•		•	•
Table 4-1	Waveform Quality (rho)							•	•	•		•		•		•	•			•
Table 4-1	Pilot Time Offset							•	•	•		•		•		•	•			•
Table 4-1	Code Domain Power / Noise Floor								•	•	•									
Table 4-1	FER Test						•	•	•	•	•									
<b>NOTE</b>																				
Replace power converters one card at a time so that power to the SCCP shelf is not lost. If power to the shelf is lost, all cards in the shelf must be downloaded again.																				

# Appendix C: BBX Gain Set Point vs. BTS Output Considerations

## Appendix Content

---

Usage & Background .....	C-1
--------------------------	-----





# Appendix C: BBX2 Gain Set Point vs. BTS Output Considerations

## Usage & Background

Table C-1 outlines the relationship between the *total* of all code domain channel element gain settings (digital root sum of the squares) and the BBX2 Gain Set Point between 33.0 dBm and 44.0 dBm. The resultant RF output (as measured at the top of the BTS in dBm) is shown in the table. The table assumes that the BBX2 Bay Level Offset (BLO) values have been calculated.

As an illustration, consider a BBX2 keyed up to produce a CDMA carrier with only the Pilot channel (no MCCs forward link enabled). Pilot gain is set to 262. In this case, the BBX2 Gain Set Point is shown to correlate exactly to the actual RF output anywhere in the 33 to 44 dBm output range. (This is the level used to calibrate the BTS).

**Table C-1: BBX2 Gain Set Point vs. Actual BTS Output (in dBm)**

dBm↗ Gain↘	44	43	42	41	40	39	38	37	36	35	34	33
541	–	–	–	–	–	–	–	43.3	42.3	41.3	40.3	39.3
533	–	–	–	–	–	–	–	43.2	42.2	41.2	40.2	39.2
525	–	–	–	–	–	–	–	43	42	41	40	39
517	–	–	–	–	–	–	–	42.9	41.9	40.9	39.9	38.9
509	–	–	–	–	–	–	–	42.8	41.8	40.8	39.8	38.8
501	–	–	–	–	–	–	–	42.6	41.6	40.6	39.6	38.6
493	–	–	–	–	–	–	43.5	42.5	41.5	40.5	39.5	38.5
485	–	–	–	–	–	–	43.4	42.4	41.4	40.4	39.4	38.4
477	–	–	–	–	–	–	43.2	42.2	41.2	40.2	39.2	38.2
469	–	–	–	–	–	–	43.1	42.1	41.1	40.1	39.1	38.1
461	–	–	–	–	–	–	42.9	41.9	40.9	39.9	38.9	37.9
453	–	–	–	–	–	–	42.8	41.8	40.8	39.8	38.8	37.8
445	–	–	–	–	–	43.6	42.6	41.6	40.6	39.6	38.6	37.6
437	–	–	–	–	–	43.4	42.4	41.4	40.4	39.4	38.4	37.4
429	–	–	–	–	–	43.3	42.3	41.3	40.3	39.3	38.3	37.3
421	–	–	–	–	–	43.1	42.1	41.1	40.1	39.1	38.1	37.1
413	–	–	–	–	–	43	42	41	40	39	38	37
405	–	–	–	–	–	42.8	41.8	40.8	39.8	38.8	37.8	36.8
397	–	–	–	–	43.6	42.6	41.6	40.6	39.6	38.6	37.6	36.6
389	–	–	–	–	43.4	42.4	41.4	40.4	39.4	38.4	37.4	36.4

... continued on next page



**Appendix C: BBX2 Gain Set Point vs. BTS Output Considerations** – continued

**Table C-1: BBX2 Gain Set Point vs. Actual BTS Output (in dBm)**

<b>dBm Gain</b>	<b>44</b>	<b>43</b>	<b>42</b>	<b>41</b>	<b>40</b>	<b>39</b>	<b>38</b>	<b>37</b>	<b>36</b>	<b>35</b>	<b>34</b>	<b>33</b>
<b>381</b>	–	–	–	–	43.3	42.3	41.3	40.3	39.3	38.3	37.3	36.3
<b>374</b>	–	–	–	–	43.1	42.1	41.1	40.1	39.1	38.1	37.1	36.1
<b>366</b>	–	–	–	–	42.9	41.9	40.9	39.9	38.9	37.9	36.9	35.9
<b>358</b>	–	–	–	–	42.7	41.7	40.7	39.7	38.7	37.7	36.7	35.7
<b>350</b>	–	–	–	43.5	42.5	41.5	40.5	39.5	38.5	37.5	36.5	35.5
<b>342</b>	–	–	–	43.3	42.3	41.3	40.3	39.3	38.3	37.3	36.3	35.3
<b>334</b>	–	–	–	43.1	42.1	41.1	40.1	39.1	38.1	37.1	36.1	35.1
<b>326</b>	–	–	–	42.9	41.9	40.9	39.9	38.9	37.9	36.9	35.9	34.9
<b>318</b>	–	–	–	42.7	41.7	40.7	39.7	38.7	37.7	36.7	35.7	34.7
<b>310</b>	–	–	43.5	42.5	41.5	40.5	39.5	38.5	37.5	36.5	35.5	34.5
<b>302</b>	–	–	43.2	42.2	41.2	40.2	39.2	38.2	37.2	36.2	35.2	34.2
<b>294</b>	–	–	43	42	41	40	39	38	37	36	35	34
<b>286</b>	–	–	42.8	41.8	40.8	39.8	38.8	37.8	36.8	35.8	34.8	33.8
<b>278</b>	–	43.5	42.5	41.5	40.5	39.5	38.5	37.5	36.5	35.5	34.5	33.5
<b>270</b>	–	43.3	42.3	41.3	40.3	39.3	38.3	37.3	36.3	35.3	34.3	33.3
<b>262</b>	–	43	42	41	40	39	38	37	36	35	34	33
<b>254</b>	–	42.7	41.7	40.7	39.7	38.7	37.7	36.7	35.7	34.7	33.7	32.7
<b>246</b>	43.4	42.4	41.4	40.4	39.4	38.4	37.4	36.4	35.4	34.4	33.4	32.4
<b>238</b>	43.2	42.2	41.2	40.2	39.2	38.2	37.2	36.2	35.2	34.2	33.2	32.2
<b>230</b>	42.9	41.9	40.9	39.9	38.9	37.9	36.9	35.9	34.9	33.9	32.9	31.9
<b>222</b>	42.6	41.6	40.6	39.6	38.6	37.6	36.6	35.6	34.6	33.6	32.6	31.6
<b>214</b>	42.2	41.2	40.2	39.2	38.2	37.2	36.2	35.2	34.2	33.2	32.2	31.2

**C**



# Appendix D: CDMA Operating Frequency Information

## Appendix Content

---

1900 MHz PCS Channels . . . . .	D-1
Calculating 1900 MHz Center Frequencies . . . . .	D-2
800 MHz CDMA Channels . . . . .	D-4
Calculating 800 MHz Center Frequencies . . . . .	D-4





# CDMA Operating Frequency Programming Information – North American PCS Bands

## Introduction

Programming of each of the BTS BBX2 synthesizers is performed by the BTS GLI2s via the CHI bus. This programming data determines the transmit and receive transceiver operating frequencies (channels) for each BBX2.

## 1900 MHz PCS Channels

Figure D-1 shows the valid channels for the North American PCS 1900 MHz frequency spectrum. There are 10 CDMA wireline or non-wireline band channels used in a CDMA system (unique per customer operating system).

**Figure D-1:** North America PCS Frequency Spectrum (CDMA Allocation)

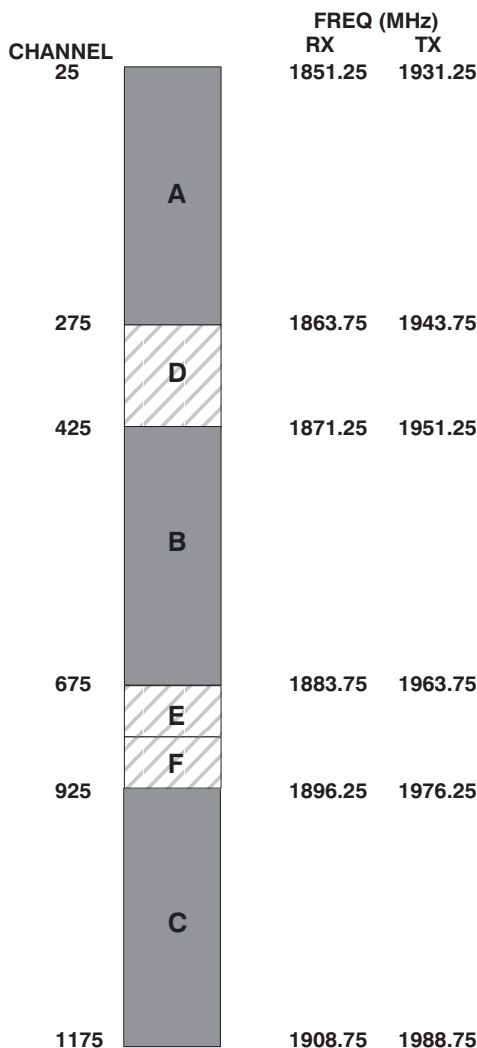

FW00463



# CDMA Operating Frequency Programming Information – North American Bands – continued

## Calculating 1900 MHz Center Frequencies

Table D-1 shows selected 1900 MHz CDMA candidate operating channels, listed in both decimal and hexadecimal, and the corresponding transmit, and receive frequencies. Center frequencies (in MHz) for channels not shown in the table may be calculated as follows:

- $TX = 1930 + 0.05 * \text{Channel\#}$   
**Example:** Channel 262  
 $TX = 1930 + 0.05 * 262 = 1943.10 \text{ MHz}$
- $RX = TX - 80$   
**Example:** Channel 262  
 $RX = 1943.10 - 80 = 1863.10 \text{ MHz}$

Actual frequencies used depend on customer CDMA system frequency plan.

Each CDMA channel requires a 1.77 MHz frequency segment. The actual CDMA carrier is 1.23 MHz wide, with a 0.27 MHz guard band on both sides of the carrier.

Minimum frequency separation required between any CDMA carrier and the nearest NAMPS/AMPS carrier is 900 kHz (center-to-center).

**Table D-1:** 1900 MHz TX and RX Frequency vs. Channel

Channel Number		Transmit Frequency (MHz) Center Frequency	Receive Frequency (MHz) Center Frequency
Decimal	Hex		
25	0019	1931.25	1851.25
50	0032	1932.50	1852.50
75	004B	1933.75	1853.75
100	0064	1935.00	1855.00
125	007D	1936.25	1856.25
150	0096	1937.50	1857.50
175	00AF	1938.75	1858.75
200	00C8	1940.00	1860.00
225	00E1	1941.25	1861.25
250	00FA	1942.50	1862.50
275	0113	1943.75	1863.75
300	012C	1945.00	1865.00
325	0145	1946.25	1866.25
350	015E	1947.50	1867.50
375	0177	1948.75	1868.75
400	0190	1950.00	1870.00
425	01A9	1951.25	1871.25
450	01C2	1952.50	1872.50
475	01DB	1953.75	1873.75
500	01F4	1955.00	1875.00
525	020D	1956.25	1876.25
550	0226	1957.50	1877.50
575	023F	1958.75	1878.75

... continued on next page

# CDMA Operating Frequency Programming Information – North American Bands – continued

**Table D-1: 1900 MHz TX and RX Frequency vs. Channel**

Channel Number		Transmit Frequency (MHz)	Receive Frequency (MHz)
Decimal	Hex	Center Frequency	Center Frequency
600	0258	1960.00	1880.00
625	0271	1961.25	1881.25
650	028A	1962.50	1882.50
675	02A3	1963.75	1883.75
700	02BC	1965.00	1885.00
725	02D5	1966.25	1886.25
750	02EE	1967.50	1887.50
775	0307	1968.75	1888.75
800	0320	1970.00	1890.00
825	0339	1971.25	1891.25
850	0352	1972.50	1892.50
875	036B	1973.75	1893.75
900	0384	1975.00	1895.00
925	039D	1976.25	1896.25
950	03B6	1977.50	1897.50
975	03CF	1978.75	1898.75
1000	03E8	1980.00	1900.00
1025	0401	1981.25	1901.25
1050	041A	1982.50	1902.50
1075	0433	1983.75	1903.75
1100	044C	1985.00	1905.00
1125	0465	1986.25	1906.25
1150	047E	1987.50	1807.50
1175	0497	1988.75	1908.75

D

# CDMA Operating Frequency Programming Information – North American Bands – continued

## 800 MHz CDMA Channels

Figure D-2 shows the valid channels for the North American cellular telephone frequency spectrum. There are 10 CDMA wireline or non-wireline band channels used in a CDMA system (unique per customer operating system).

**Figure D-2:** North American Cellular Telephone System Frequency Spectrum (CDMA Allocation).

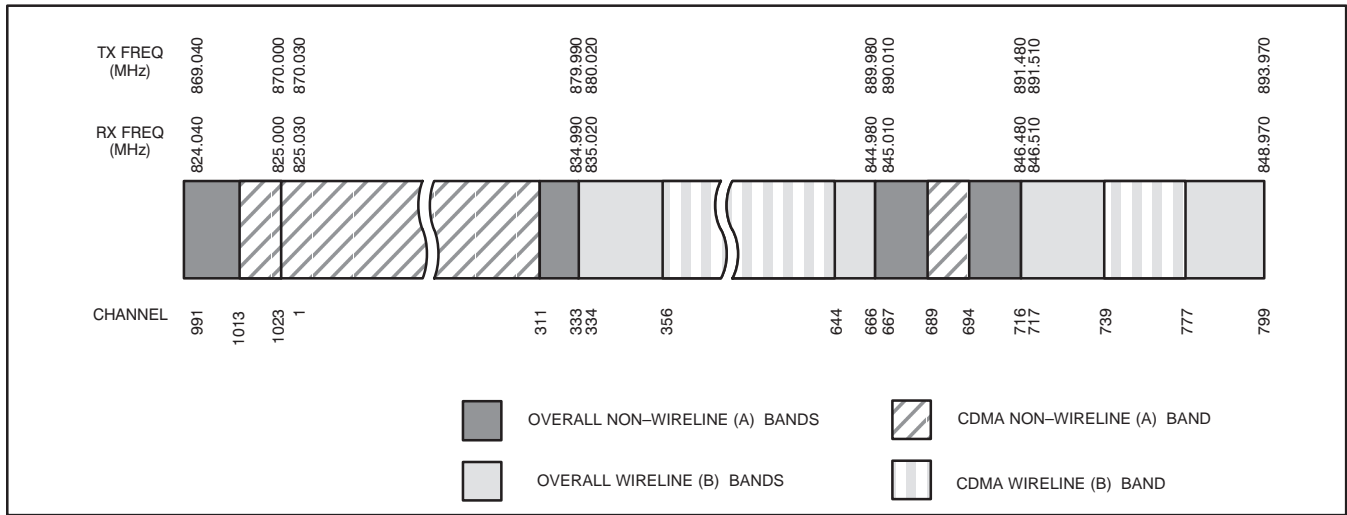

FW00402

## Calculating 800 MHz Center Frequencies

Table D-2 shows selected 800 MHz CDMA candidate operating channels, listed in both decimal and hexadecimal, and the corresponding transmit, and receive frequencies. Center frequencies (in MHz) for channels not shown in the table may be calculated as follows:

- Channels 1–777  
 $TX = 870 + 0.03 * \text{Channel\#}$   
**Example:** Channel 262  
 $TX = 870 + 0.03 * 262 = 877.86 \text{ MHz}$
- Channels 1013–1023  
 $TX = 870 + 0.03 * (\text{Channel\#} - 1023)$   
**Example:** Channel 1015  
 $TX = 870 + 0.03 * (1015 - 1023) = 869.76 \text{ MHz}$
- $RX = TX - 45 \text{ MHz}$   
**Example:** Channel 262  
 $RX = 877.86 - 45 = 832.86 \text{ MHz}$

**Table D-2:** 800 MHz TX and RX Frequency vs. Channel

Channel Number		Transmit Frequency (MHz) Center Frequency	Receive Frequency (MHz) Center Frequency
Decimal	Hex		
1	0001	870.0300	825.0300
25	0019	870.7500	825.7500

... continued on next page

# CDMA Operating Frequency Programming Information – North American Bands – continued

**Table D-2: 800 MHz TX and RX Frequency vs. Channel**

Channel Number		Transmit Frequency (MHz) Center Frequency	Receive Frequency (MHz) Center Frequency
Decimal	Hex		
50	0032	871.5000	826.5000
75	004B	872.2500	827.2500
100	0064	873.0000	828.0000
125	007D	873.7500	828.7500
150	0096	874.5000	829.5000
175	00AF	875.2500	830.2500
200	00C8	876.0000	831.0000
225	00E1	876.7500	831.7500
250	00FA	877.5000	832.5000
275	0113	878.2500	833.2500
300	012C	879.0000	834.0000
325	0145	879.7500	834.7500
350	015E	880.5000	835.5000
375	0177	881.2500	836.2500
400	0190	882.0000	837.0000
425	01A9	882.7500	837.7500
450	01C2	883.5000	838.5000
475	01DB	884.2500	839.2500
500	01F4	885.0000	840.0000
525	020D	885.7500	840.7500
550	0226	886.5000	841.5000
575	023F	887.2500	842.2500
600	0258	888.0000	843.0000
625	0271	888.7500	843.7500
650	028A	889.5000	844.5000
675	02A3	890.2500	845.2500
700	02BC	891.0000	846.0000
725	02D5	891.7500	846.7500
750	02EE	892.5000	847.5000
775	0307	893.2500	848.2500
<b>NOTE</b>			
Channel numbers 778 through 1012 are not used.			
1013	03F5	869.7000	824.7000
1023	03FF	870.0000	825.0000

D





# Appendix E: PN Offset/I & Q Offset Register Programming Information

## Appendix Content

---

PN Offset Background .....	E-1
PN Offset Usage .....	E-1



# Appendix E: PN Offset Programming Information

## PN Offset Background

All channel elements transmitted from a BTS in a particular 1.25 MHz CDMA channel are orthonogonally spread by 1 of 64 possible Walsh code functions; additionally, they are also spread by a quadrature pair of PN sequences unique to each sector.

Overall, the mobile uses this to differentiate multiple signals transmitted from the same BTS (and surrounding BTS) sectors, and to synchronize to the next strongest sector.

The PN offset per sector is stored on the BBX2s, where the corresponding I & Q registers reside.

The PN offset values are determined on a per BTS/per sector(antenna) basis as determined by the appropriate cdf file content. A breakdown of this information is found in Table E-1.

## PN Offset Usage

There are three basic RF chip delays currently in use. It is important to determine what RF chip delay is valid to be able to test the BTS functionality. This can be done by ascertaining if the CDF file `FineTxAdj` value was set to “on” when the MCC was downloaded with “image data”. The `FineTxAdj` value is used to compensate for the processing delay (approximately 20  $\mu$ S) in the BTS using any type of mobile meeting IS-97 specifications.

Observe the following guidelines:

- If the `FineTxAdj` value in the cdf file is 101 (65 HEX), the `FineTxAdj` has not been set. The I and Q values from the 0 table MUST be used.

If the `FineTxAdj` value in the cdf file is 213 (D5 HEX), `FineTxAdj` has been set for the *14 chip table*.

- If the `FineTxAdj` value in the cdf file is 197 (C5 HEX), `FineTxAdj` has been set for the *13 chip table*.



### IMPORTANT

CDF file I and Q values can be represented in DECIMAL or HEX. If using HEX, add 0x before the HEX value. If necessary, convert HEX values in Table E-1 to decimal before comparing them to cdf file I & Q value assignments.

- If you are using a Qualcomm mobile, use the I and Q values from the 13 chip delay table.
- If you are using a mobile that does not have the 1 chip offset problem, (any mobile meeting the IS-97 specification), use the 14 chip delay table.



**IMPORTANT**

If the wrong I and Q values are used with the wrong `FineTxAdj` parameter, system timing problems will occur. This will cause the energy transmitted to be “smeared” over several Walsh codes (instead of the single Walsh code that it was assigned to), causing erratic operation. Evidence of smearing is usually identified by Walsh channels not at correct levels or present when not selected in the Code Domain Power Test.

# Appendix E: PN Offset Programming Information – continued

**Table E-1: PnMaskI and PnMaskQ Values for PilotPn**

Pilot PN	14-Chip Delay				13-Chip Delay				0-Chip Delay				
	I (Dec.)	Q	I	Q	I	Q	I	Q	I	Q	I	Q	
			(Hex.)		(Dec.)		(Hex.)		(Dec.)		(Hex.)		
0	17523	23459	4473	5BA3	29673	25581	73E9	63ED	4096	4096	1000	1000	
1	32292	32589	7E24	7F4D	16146	29082	3F12	719A	9167	1571	23CF	0623	
2	4700	17398	125C	43F6	2350	8699	092E	21FB	22417	7484	5791	1D3C	
3	14406	26333	3846	66DD	7203	32082	1C23	7D52	966	6319	03C6	18AF	
4	14899	4011	3A33	0FAB	19657	18921	4CC9	49E9	14189	2447	376D	098F	
5	17025	2256	4281	08D0	28816	1128	7090	0468	29150	24441	71DE	5F79	
6	14745	18651	3999	48DB	19740	27217	4D1C	6A51	18245	27351	4745	6AD7	
7	2783	1094	0ADF	0446	21695	547	54BF	0223	1716	23613	06B4	5C3D	
8	5832	21202	16C8	52D2	2916	10601	0B64	2969	11915	29008	2E8B	7150	
9	12407	13841	3077	3611	18923	21812	49EB	5534	20981	5643	51F5	160B	
10	31295	31767	7A3F	7C17	27855	28727	6CCF	7037	24694	28085	6076	6DB5	
11	7581	18890	1D9D	49CA	24350	9445	5F1E	24E5	11865	18200	2E59	4718	
12	18523	30999	485B	7917	30205	29367	75FD	72B7	6385	21138	18F1	5292	
13	29920	22420	74E0	5794	14960	11210	3A70	2BCA	27896	21937	6CF8	55B1	
14	25184	20168	6260	4EC8	12592	10084	3130	2764	25240	25222	6298	6286	
15	26282	12354	66AA	3042	13141	6177	3355	1821	30877	109	789D	006D	
16	30623	11187	779F	2BB3	27167	23525	6A1F	5BE5	30618	6028	779A	178C	
17	15540	11834	3CB4	2E3A	7770	5917	1E5A	171D	26373	22034	6705	5612	
18	23026	10395	59F2	289B	11513	23153	2CF9	5A71	314	15069	013A	3ADD	
19	20019	28035	4E33	6D83	30409	30973	76C9	78FD	17518	4671	446E	123F	
20	4050	27399	0FD2	6B07	2025	31679	07E9	7BBF	21927	30434	55A7	76E2	
21	1557	22087	0615	5647	21210	25887	52DA	651F	2245	11615	08C5	2D5F	
22	30262	2077	7636	081D	15131	18994	3B1B	4A32	18105	19838	46B9	4D7E	
23	18000	13758	4650	35BE	9000	6879	2328	1ADF	8792	14713	2258	3979	
24	20056	11778	4E58	2E02	10028	5889	272C	1701	21440	241	53C0	00F1	
25	12143	3543	2F6F	0DD7	18023	18647	4667	48D7	15493	24083	3C85	5E13	
26	17437	7184	441D	1C10	29662	3592	73DE	0E08	26677	7621	6835	1DC5	
27	17438	2362	441E	093A	8719	1181	220F	049D	11299	19144	2C23	4AC8	
28	5102	25840	13EE	64F0	2551	12920	09F7	3278	12081	1047	2F31	0417	
29	9302	12177	2456	2F91	4651	23028	122B	59F4	23833	26152	5D19	6628	
30	17154	10402	4302	28A2	8577	5201	2181	1451	20281	22402	4F39	5782	
31	5198	1917	144E	077D	2599	19842	0A27	4D82	10676	21255	29B4	5307	
32	4606	17708	11FE	452C	2303	8854	08FF	2296	16981	30179	4255	75E3	
33	24804	10630	60E4	2986	12402	5315	3072	14C3	31964	7408	7CDC	1CF0	
34	17180	6812	431C	1A9C	8590	3406	218E	0D4E	26913	115	6921	0073	
35	10507	14350	290B	380E	17749	7175	4555	1C07	14080	1591	3700	0637	
36	10157	10999	27AD	2AF7	16902	23367	4206	5B47	23842	1006	5D22	03EE	
37	23850	25003	5D2A	61AB	11925	32489	2E95	7EE9	27197	32263	6A3D	7E07	
38	31425	2652	7AC1	0A5C	27824	1326	6CB0	052E	22933	1332	5995	0534	
39	4075	19898	0FEB	4DBA	22053	9949	5625	26DD	30220	12636	760C	315C	
40	10030	2010	272E	07DA	5015	1005	1397	03ED	12443	4099	309B	1003	
41	16984	25936	4258	6550	8492	12968	212C	32A8	19854	386	4D8E	0182	
42	14225	28531	3791	6F73	18968	31109	4A18	7985	14842	29231	39FA	722F	
43	26519	11952	6797	2EB0	25115	5976	621B	1758	15006	25711	3A9E	646F	
44	27775	31947	6C7F	7CCB	26607	28761	67EF	7059	702	10913	02BE	2AA1	
45	30100	25589	7594	63F5	15050	32710	3ACA	7FC6	21373	8132	537D	1FC4	
46	7922	11345	1EF2	2C51	3961	22548	0F79	5814	23874	20844	5D42	516C	
47	14199	28198	3777	6E26	19051	14099	4A6B	3713	3468	13150	0D8C	335E	
48	17637	13947	44E5	367B	29602	21761	73A2	5501	31323	18184	7A5B	4708	
49	23081	8462	5A29	210E	31940	4231	7CC4	1087	29266	19066	7252	4A7A	
50	5099	9595	13EB	257B	22565	23681	5825	5C81	16554	29963	40AA	750B	

... continued on next page



# Appendix E: PN Offset Programming Information – continued

**Table E-1: PnMaskI and PnMaskQ Values for PilotPn**

Pilot PN	14-Chip Delay				13-Chip Delay				0-Chip Delay			
	I (Dec.)	Q (Dec.)	I (Hex.)	Q (Hex.)	I (Dec.)	Q (Dec.)	I (Hex.)	Q (Hex.)	I (Dec.)	Q (Dec.)	I (Hex.)	Q (Hex.)
51	32743	4670	7FE7	123E	28195	2335	6E23	091F	22575	6605	582F	19CD
52	7114	14672	1BCA	3950	3557	7336	0DE5	1CA8	31456	29417	7AE0	72E9
53	7699	29415	1E13	72E7	24281	30543	5ED9	774F	8148	22993	1FD4	59D1
54	19339	20610	4B8B	5082	29717	10305	7415	2841	19043	27657	4A63	6C09
55	28212	6479	6E34	194F	14106	17051	371A	429B	25438	5468	635E	155C
56	29587	10957	7393	2ACD	26649	23386	6819	5B5A	10938	8821	2ABA	2275
57	19715	18426	4D03	47FA	30545	9213	7751	23FD	2311	20773	0907	5125
58	14901	22726	3A35	58C6	19658	11363	4CCA	2C63	7392	4920	1CE0	1338
59	20160	5247	4EC0	147F	10080	17411	2760	4403	30714	5756	77FA	167C
60	22249	29953	56E9	7501	31396	29884	7AA4	74BC	180	28088	00B4	6DB8
61	26582	5796	67D6	16A4	13291	2898	33EB	0B52	8948	740	22F4	02E4
62	7153	16829	1BF1	41BD	23592	28386	5C28	6EE2	16432	23397	4030	5B65
63	15127	4528	3B17	11B0	19547	2264	4C5B	08D8	9622	19492	2596	4C24
64	15274	5415	3BAA	1527	7637	17583	1DD5	44AF	7524	26451	1D64	6753
65	23149	10294	5A6D	2836	31974	5147	7CE6	141B	1443	30666	05A3	77CA
66	16340	17046	3FD4	4296	8170	8523	1FEA	214B	1810	15088	0712	3AF0
67	27052	7846	69AC	1EA6	13526	3923	34D6	0F53	6941	26131	1B1D	6613
68	13519	10762	34CF	2A0A	19383	5381	4BB7	1505	3238	15969	0CA6	3E61
69	10620	13814	297C	35F6	5310	6907	14BE	1AFB	8141	24101	1FCD	5E25
70	15978	16854	3E6A	41D6	7989	8427	1F35	20EB	10408	12762	28A8	31DA
71	27966	795	6D3E	031B	13983	20401	369F	4FB1	18826	19997	498A	4E1D
72	12479	9774	30BF	262E	18831	4887	498F	1317	22705	22971	58B1	59BB
73	1536	24291	0600	5EE3	768	24909	0300	614D	3879	12560	0F27	3110
74	3199	3172	0C7F	0C64	22511	1586	57EF	0632	21359	31213	536F	79ED
75	4549	2229	11C5	08B5	22834	19046	5932	4A66	30853	18780	7885	495C
76	17888	21283	45E0	5323	8944	26541	22F0	67AD	18078	16353	469E	3FE1
77	13117	16905	333D	4209	18510	28472	484E	6F38	15910	12055	3E26	2F17
78	7506	7062	1D52	1B96	3753	3531	0EA9	0DCB	20989	30396	51FD	76BC
79	27626	7532	6BEA	1D6C	13813	3766	35F5	0EB6	28810	24388	708A	5F44
80	31109	25575	7985	63E7	27922	32719	6D12	7FCF	30759	1555	7827	0613
81	29755	14244	743B	37A4	27597	7122	6BCD	1BD2	18899	13316	49D3	3404
82	26711	28053	6857	6D95	26107	30966	65FB	78F6	7739	31073	1E3B	7961
83	20397	30408	4FAD	76C8	30214	15204	7606	3B64	6279	6187	1887	182B
84	18608	5094	48B0	13E6	9304	2547	2458	09F3	9968	21644	26F0	548C
85	7391	16222	1CDF	3F5E	24511	8111	5FBF	1FAF	8571	9289	217B	2449
86	23168	7159	5A80	1BF7	11584	17351	2D40	43C7	4143	4624	102F	1210
87	23466	174	5BAA	00AE	11733	87	2DD5	0057	19637	467	4CB5	01D3
88	15932	25530	3E3C	63BA	7966	12765	1F1E	31DD	11867	18133	2E5B	46D5
89	25798	2320	64C6	0910	12899	1160	3263	0488	7374	1532	1CCE	05FC
90	28134	23113	6DE6	5A49	14067	25368	36F3	6318	10423	1457	28B7	05B1
91	28024	23985	6D78	5DB1	14012	24804	36BC	60E4	9984	9197	2700	23ED
92	6335	2604	18BF	0A2C	23951	1302	5D8F	0516	7445	13451	1D15	348B
93	21508	1826	5404	0722	10754	913	2A02	0391	4133	25785	1025	64B9
94	26338	30853	66E2	7885	13169	29310	3371	727E	22646	4087	5876	0FF7
95	17186	15699	4322	3D53	8593	20629	2191	5095	15466	31190	3C6A	79D6
96	22462	2589	57BE	0A1D	11231	19250	2BDF	4B32	2164	8383	0874	20BF
97	3908	25000	0F44	61A8	1954	12500	07A2	30D4	16380	12995	3FFC	32C3
98	25390	18163	632E	46F3	12695	27973	3197	6D45	15008	27438	3AA0	6B2E
99	27891	12555	6CF3	310B	26537	22201	67A9	56B9	31755	9297	7C0B	2451
100	9620	8670	2594	21DE	4810	4335	12CA	10EF	31636	1676	7B94	068C

... continued on next page

# Appendix E: PN Offset Programming Information – continued

**Table E-1: PnMaskI and PnMaskQ Values for PilotPn**

Pilot PN	14-Chip Delay				13-Chip Delay				0-Chip Delay			
	I (Dec.)	Q (Dec.)	I (Hex.)	Q (Hex.)	I (Dec.)	Q (Dec.)	I (Hex.)	Q (Hex.)	I (Dec.)	Q (Dec.)	I (Hex.)	Q (Hex.)
101	6491	1290	195B	050A	23933	645	5D7D	0285	25414	12596	6346	3134
102	16876	4407	41EC	1137	8438	18087	20F6	46A7	7102	19975	1BBE	4E07
103	17034	1163	428A	048B	8517	19577	2145	4C79	20516	20026	5024	4E3A
104	32405	12215	7E95	2FB7	28314	23015	6E9A	59E7	19495	8958	4C27	22FE
105	27417	7253	6B19	1C55	25692	16406	645C	4016	17182	19143	431E	4AC7
106	8382	8978	20BE	2312	4191	4489	105F	1189	11572	17142	2D34	42F6
107	5624	25547	15F8	63CB	2812	32729	0AFC	7FD9	25570	19670	63E2	4CD6
108	1424	3130	0590	0C3A	712	1565	02C8	061D	6322	30191	18B2	75EF
109	13034	31406	32EA	7AAE	6517	15703	1975	3D57	8009	5822	1F49	16BE
110	15682	6222	3D42	184E	7841	3111	1EA1	0C27	26708	22076	6854	563C
111	27101	20340	69DD	4F74	25918	10170	653E	27BA	6237	606	185D	025E
112	8521	25094	2149	6206	16756	12547	4174	3103	32520	9741	7F08	260D
113	30232	23380	7618	5B54	15116	11690	3B0C	2DAA	31627	9116	7B8B	239C
114	6429	10926	191D	2AAE	23902	5463	5D5E	1557	3532	12705	0DCC	31A1
115	27116	22821	69EC	5925	13558	25262	34F6	62AE	24090	17502	5E1A	445E
116	4238	31634	108E	7B92	2119	15817	0847	3DC9	20262	18952	4F26	4A08
117	5128	4403	1408	1133	2564	18085	0A04	46A5	18238	15502	473E	3C8E
118	14846	689	39FE	02B1	7423	20324	1CFF	4F64	2033	17819	07F1	459B
119	13024	27045	32E0	69A5	6512	31470	1970	7AEE	25566	4370	63DE	1112
120	10625	27557	2981	6BA5	17680	31726	4510	7BEE	25144	31955	6238	7CD3
121	31724	16307	7BEC	3FB3	15862	20965	3DF6	51E5	29679	30569	73EF	7769
122	13811	22338	35F3	5742	19241	11169	4B29	2BA1	5064	7350	13C8	1CB6
123	24915	27550	6153	6B9E	24953	13775	6179	35CF	27623	26356	6BE7	66F4
124	1213	22096	04BD	5650	21390	11048	538E	2B28	13000	32189	32C8	7DBD
125	2290	23136	08F2	5A60	1145	11568	0479	2D30	31373	1601	7A8D	0641
126	31551	12199	7B3F	2FA7	27727	23023	6C4F	59EF	13096	19537	3328	4C51
127	12088	1213	2F38	04BD	6044	19554	179C	4C62	26395	25667	671B	6443
128	7722	936	1E2A	03A8	3861	468	0F15	01D4	15487	4415	3C7F	113F
129	27312	6272	6AB0	1880	13656	3136	3558	0C40	29245	2303	723D	08FF
130	23130	32446	5A5A	7EBE	11565	16223	2D2D	3F5F	26729	16362	6869	3FEA
131	594	13555	0252	34F3	297	21573	0129	5445	12568	28620	3118	6FCC
132	25804	8789	64CC	2255	12902	24342	3266	5F16	24665	6736	6059	1A50
133	31013	24821	7925	60F5	27970	32326	6D42	7E46	8923	2777	22DB	0AD9
134	32585	21068	7F49	524C	28276	10534	6E74	2926	19634	24331	4CB2	5F0B
135	3077	31891	0C05	7C93	22482	28789	57D2	7075	29141	9042	71D5	2352
136	17231	5321	434F	14C9	28791	17496	7077	4458	73	107	0049	006B
137	31554	551	7B42	0227	15777	20271	3DA1	4F2F	26482	4779	6772	12AB
138	8764	12115	223C	2F53	4382	22933	111E	5995	6397	13065	18FD	3309
139	15375	4902	3C0F	1326	20439	2451	4FD7	0993	29818	30421	747A	76D5
140	13428	1991	3474	07C7	6714	19935	1A3A	4DDF	8153	20210	1FD9	4EF2
141	17658	14404	44FA	3844	8829	7202	227D	1C22	302	5651	012E	1613
142	13475	17982	34A3	463E	19329	8991	4B81	231F	28136	31017	6DE8	7929
143	22095	19566	564F	4C6E	31479	9783	7AF7	2637	29125	30719	71C5	77FF
144	24805	2970	60E5	0B9A	24994	1485	61A2	05CD	8625	23104	21B1	5A40
145	4307	23055	10D3	5A0F	22969	25403	59B9	633B	26671	7799	682F	1E77
146	23292	15158	5AFC	3B36	11646	7579	2D7E	1D9B	6424	17865	1918	45C9
147	1377	29094	0561	71A6	21344	14547	5360	38D3	12893	26951	325D	6947
148	28654	653	6FEE	028D	14327	20346	37F7	4F7A	18502	25073	4846	61F1
149	6350	19155	18CE	4AD3	3175	27477	0C67	6B55	7765	32381	1E55	7E7D
150	16770	23588	4182	5C24	8385	11794	20C1	2E12	25483	16581	638B	40C5

... continued on next page



# Appendix E: PN Offset Programming Information – continued

**Table E-1: PnMaskI and PnMaskQ Values for PilotPn**

Pilot PN	14-Chip Delay				13-Chip Delay				0-Chip Delay			
	I (Dec.)	Q	I (Hex.)	Q	I (Dec.)	Q	I (Hex.)	Q	I (Dec.)	Q	I (Hex.)	Q
151	14726	10878	3986	2A7E	7363	5439	1CC3	153F	15408	32087	3C30	7D57
152	25685	31060	6455	7954	25594	15530	63FA	3CAA	6414	97	190E	0061
153	21356	30875	536C	789B	10678	29297	29B6	7271	8164	7618	1FE4	1DC2
154	12149	11496	2F75	2CE8	18026	5748	466A	1674	10347	93	286B	005D
155	28966	24545	7126	5FE1	14483	25036	3893	61CC	29369	16052	72B9	3EB4
156	22898	9586	5972	2572	11449	4793	2CB9	12B9	10389	14300	2895	37DC
157	1713	20984	06B1	51F8	21128	10492	5288	28FC	24783	11129	60CF	2B79
158	30010	30389	753A	76B5	15005	30054	3A9D	7566	18400	6602	47E0	19CA
159	2365	7298	093D	1C82	21838	3649	554E	0E41	22135	14460	5677	387C
160	27179	18934	6A2B	49F6	25797	9467	64C5	24FB	4625	25458	1211	6372
161	29740	23137	742C	5A61	14870	25356	3A16	630C	22346	15869	574A	3DFD
162	5665	24597	1621	6015	23232	32310	5AC0	7E36	2545	27047	09F1	69A7
163	23671	23301	5C77	5B05	32747	25534	7FEB	63BE	7786	26808	1E6A	68B8
164	1680	7764	0690	1E54	840	3882	0348	0F2A	20209	7354	4EF1	1CBA
165	25861	14518	6505	38B6	25426	7259	6352	1C5B	26414	27834	672E	6CBA
166	25712	21634	6470	5482	12856	10817	3238	2A41	1478	11250	05C6	2BF2
167	19245	11546	4B2D	2D1A	29766	5773	7446	168D	15122	552	3B12	0228
168	26887	26454	6907	6756	25939	13227	6553	33AB	24603	27058	601B	69B2
169	30897	15938	78B1	3E42	28040	7969	6D88	1F21	677	14808	02A5	39D8
170	11496	9050	2CE8	235A	5748	4525	1674	11AD	13705	9642	3589	25AA
171	1278	3103	04FE	0C1F	639	18483	027F	4833	13273	32253	33D9	7DFD
172	31555	758	7B43	02F6	27761	379	6C71	017B	14879	26081	3A1F	65E1
173	29171	16528	71F3	4090	26921	8264	6929	2048	6643	21184	19F3	52C0
174	20472	20375	4FF8	4F97	10236	27127	27FC	69F7	23138	11748	5A62	2DE4
175	5816	10208	16B8	27E0	2908	5104	0B5C	13F0	28838	32676	70A6	7FA4
176	30270	17698	763E	4522	15135	8849	3B1F	2291	9045	2425	2355	0979
177	22188	8405	56AC	20D5	11094	24150	2B56	5E56	10792	19455	2A28	4BFF
178	6182	28634	1826	6FDA	3091	14317	0C13	37ED	25666	19889	6442	4DB1
179	32333	1951	7E4D	079F	28406	19955	6EF6	4DF3	11546	18177	2D1A	4701
180	14046	20344	36DE	4F78	7023	10172	1B6F	27BC	15535	2492	3CAF	09BC
181	15873	26696	3E01	6848	20176	13348	4ED0	3424	16134	15086	3F06	3AEE
182	19843	3355	4D83	0D1B	30481	18609	7711	48B1	8360	30632	20A8	77A8
183	29367	11975	72B7	2EC7	26763	22879	688B	595F	14401	27549	3841	6B9D
184	13352	31942	3428	7CC6	6676	15971	1A14	3E63	26045	6911	65BD	1AFF
185	22977	9737	59C1	2609	32048	23864	7D30	5D38	24070	9937	5E06	26D1
186	31691	9638	7BCB	25A6	27701	4819	6C35	12D3	30300	2467	765C	09A3
187	10637	30643	298D	77B3	17686	30181	4516	75E5	13602	25831	3522	64E7
188	25454	13230	636E	33AE	12727	6615	31B7	19D7	32679	32236	7FA7	7DEC
189	18610	22185	48B2	56A9	9305	25960	2459	6568	16267	12987	3F8B	32BB
190	6368	2055	18E0	0807	3184	19007	0C70	4A3F	9063	11714	2367	2DC2
191	7887	8767	1ECF	223F	24247	24355	5EB7	5F23	19487	19283	4C1F	4B53
192	7730	15852	1E32	3DEC	3865	7926	0F19	1EF6	12778	11542	31EA	2D16
193	23476	16125	5BB4	3EFD	11738	20802	2DDA	5142	27309	27928	6AAD	6D18
194	889	6074	0379	17BA	20588	3037	506C	0BDD	12527	26637	30EF	680D
195	21141	31245	5295	7A0D	30874	29498	789A	733A	953	10035	03B9	2733
196	20520	15880	5028	3E08	10260	7940	2814	1F04	15958	10748	3E56	29FC
197	21669	20371	54A5	4F93	31618	27125	7B82	69F5	6068	24429	17B4	5F6D
198	15967	8666	3E5F	21DA	20223	4333	4EFF	10ED	23577	29701	5C19	7405
199	21639	816	5487	0330	31635	408	7B93	0198	32156	14997	7D9C	3A95
200	31120	22309	7990	5725	15560	26030	3CC8	65AE	32709	32235	7FC5	7DEB

... continued on next page



# Appendix E: PN Offset Programming Information – continued

**Table E-1: PnMaskI and PnMaskQ Values for PilotPn**

Pilot PN	14-Chip Delay				13-Chip Delay				0-Chip Delay			
	I (Dec.)	Q	I (Hex.)	Q	I (Dec.)	Q	I (Hex.)	Q	I (Dec.)	Q	I (Hex.)	Q
201	3698	29563	0E72	737B	1849	30593	0739	7781	23557	30766	5C05	782E
202	16322	13078	3FC2	3316	8161	6539	1FE1	198B	17638	5985	44E6	1761
203	17429	10460	4415	28DC	29658	5230	73DA	146E	3545	6823	0DD9	1AA7
204	21730	17590	54E2	44B6	10865	8795	2A71	225B	9299	20973	2453	51ED
205	17808	20277	4590	4F35	8904	27046	22C8	69A6	6323	10197	18B3	27D5
206	30068	19988	7574	4E14	15034	9994	3ABA	270A	19590	9618	4C86	2592
207	12737	6781	31C1	1A7D	18736	17154	4930	4302	7075	22705	1BA3	58B1
208	28241	32501	6E51	7EF5	26360	28998	66F8	7146	14993	5234	3A91	1472
209	20371	6024	4F93	1788	30233	3012	7619	0BC4	19916	12541	4DCC	30FD
210	13829	20520	3605	5028	19154	10260	4AD2	2814	6532	8019	1984	1F53
211	13366	31951	3436	7CCF	6683	28763	1A1B	705B	17317	22568	43A5	5828
212	25732	26063	6484	65CF	12866	31963	3242	7CDB	16562	5221	40B2	1465
213	19864	27203	4D98	6A43	9932	31517	26CC	7B1D	26923	25216	692B	6280
214	5187	6614	1443	19D6	23537	3307	5BF1	0CEB	9155	1354	23C3	054A
215	23219	10970	5AB3	2ADA	31881	5485	7C89	156D	20243	29335	4F13	7297
216	28242	5511	6E52	1587	14121	17663	3729	44FF	32391	6682	7E87	1A1A
217	6243	17119	1863	42DF	24033	28499	5DE1	6F53	20190	26128	4EDE	6610
218	445	16064	01BD	3EC0	20750	8032	510E	1F60	27564	29390	6BAC	72CE
219	21346	31614	5362	7B7E	10673	15807	29B1	3DBF	20869	8852	5185	2294
220	13256	4660	33C8	1234	6628	2330	19E4	091A	9791	6110	263F	17DE
221	18472	13881	4828	3639	9236	21792	2414	5520	714	11847	02CA	2E47
222	25945	16819	6559	41B3	25468	28389	637C	6EE5	7498	10239	1D4A	27FF
223	31051	6371	794B	18E3	28021	16973	6D75	424D	23278	6955	5AEE	1B2B
224	1093	24673	0445	6061	21490	32268	53F2	7E0C	8358	10897	20A6	2A91
225	5829	6055	16C5	17A7	23218	17903	5AB2	45EF	9468	14076	24FC	36FC
226	31546	10009	7B3A	2719	15773	23984	3D9D	5DB0	23731	12450	5CB3	30A2
227	29833	5957	7489	1745	27540	17822	6B94	459E	25133	8954	622D	22FA
228	18146	11597	46E2	2D4D	9073	22682	2371	589A	2470	19709	09A6	4CFD
229	24813	22155	60ED	568B	24998	25977	61A6	6579	17501	1252	445D	04E4
230	47	15050	002F	3ACA	20935	7525	51C7	1D65	24671	15142	605F	3B26
231	3202	16450	0C82	4042	1601	8225	0641	2021	11930	26958	2E9A	694E
232	21571	27899	5443	6CFB	31729	30785	7BF1	7841	9154	8759	23C2	2237
233	7469	2016	1D2D	07E0	24390	1008	5F46	03F0	7388	12696	1CDC	3198
234	25297	17153	62D1	4301	24760	28604	60B8	6FBC	3440	11936	0D70	2EA0
235	8175	15849	1FEF	3DE9	24103	20680	5E27	50C8	27666	25635	6C12	6423
236	28519	30581	6F67	7775	26211	30086	6663	7586	22888	17231	5968	434F
237	4991	3600	137F	0E10	22639	1800	586F	0708	13194	22298	338A	571A
238	7907	4097	1EE3	1001	24225	17980	5EA1	463C	26710	7330	6856	1CA2
239	17728	671	4540	029F	8864	20339	22A0	4F73	7266	30758	1C62	7826
240	14415	20774	384F	5126	19959	10387	4DF7	2893	15175	6933	3B47	1B15
241	30976	24471	7900	5F97	15488	25079	3C80	61F7	15891	2810	3E13	0AFA
242	26376	27341	6708	6ACD	13188	31578	3384	7B5A	26692	8820	6844	2274
243	19063	19388	4A77	4BEC	29931	9694	74EB	25DE	14757	7831	39A5	1E97
244	19160	25278	4AD8	62BE	9580	12639	256C	315F	28757	19584	7055	4C80
245	3800	9505	0ED8	2521	1900	23724	076C	5CAC	31342	2944	7A6E	0B80
246	8307	26143	2073	661F	16873	32051	41E9	7D33	19435	19854	4BEB	4D8E
247	12918	13359	3276	342F	6459	21547	193B	542B	2437	10456	0985	28D8
248	19642	2154	4CBA	086A	9821	1077	265D	0435	20573	17036	505D	428C
249	24873	13747	6129	35B3	24900	21733	6144	54E5	18781	2343	495D	0927
250	22071	27646	5637	6BFE	31435	13823	7ACB	35FF	18948	14820	4A04	39E4

... continued on next page

# Appendix E: PN Offset Programming Information – continued

**Table E-1: PnMaskI and PnMaskQ Values for PilotPn**

Pilot PN	14-Chip Delay				13-Chip Delay				0-Chip Delay			
	I (Dec.)	Q (Dec.)	I (Hex.)	Q (Hex.)	I (Dec.)	Q (Dec.)	I (Hex.)	Q (Hex.)	I (Dec.)	Q (Dec.)	I (Hex.)	Q (Hex.)
251	13904	1056	3650	0420	6952	528	1B28	0210	23393	1756	5B61	06DC
252	27198	1413	6A3E	0585	13599	19710	351F	4CFE	5619	19068	15F3	4A7C
253	3685	3311	0E65	0CEF	22242	18507	56E2	484B	17052	28716	429C	702C
254	16820	4951	41B4	1357	8410	18327	20DA	4797	21292	31958	532C	7CD6
255	22479	749	57CF	02ED	31287	20298	7A37	4F4A	2868	16097	0B34	3EE1
256	6850	6307	1AC2	18A3	3425	17005	0D61	426D	19538	1308	4C52	051C
257	15434	961	3C4A	03C1	7717	20444	1E25	4FDC	24294	3320	5EE6	0CF8
258	19332	2358	4B84	0936	9666	1179	25C2	049B	22895	16682	596F	412A
259	8518	28350	2146	6EBE	4259	14175	10A3	375F	27652	6388	6C04	18F4
260	14698	31198	396A	79DE	7349	15599	1CB5	3CEF	29905	12828	74D1	321C
261	21476	11467	53E4	2CCB	10738	22617	29F2	5859	21415	3518	53A7	0DBE
262	30475	8862	770B	229E	27221	4431	6A55	114F	1210	3494	04BA	0DA6
263	23984	6327	5DB0	18B7	11992	16999	2ED8	4267	22396	6458	577C	193A
264	1912	7443	0778	1D13	956	16565	03BC	40B5	26552	10717	67B8	29DD
265	26735	28574	686F	6F9E	26087	14287	65E7	37CF	24829	8463	60FD	210F
266	15705	25093	3D59	6205	20348	32574	4F7C	7F3E	8663	27337	21D7	6AC9
267	3881	6139	0F29	17FB	22084	17857	5644	45C1	991	19846	03DF	4D86
268	20434	22047	4FD2	561F	10217	25907	27E9	6533	21926	9388	55A6	24AC
269	16779	32545	418B	7F21	28949	29100	7115	71AC	23306	21201	5B0A	52D1
270	31413	7112	7AB5	1BC8	27786	3556	6C8A	0DE4	13646	31422	354E	7ABE
271	16860	28535	41DC	6F77	8430	31111	20EE	7987	148	166	0094	00A6
272	8322	10378	2082	288A	4161	5189	1041	1445	24836	28622	6104	6FCE
273	28530	15065	6F72	3AD9	14265	21328	37B9	5350	24202	6477	5E8A	194D
274	26934	5125	6936	1405	13467	17470	349B	443E	9820	10704	265C	29D0
275	18806	12528	4976	30F0	9403	6264	24BB	1878	12939	25843	328B	64F3
276	20216	23215	4EF8	5AAF	10108	25451	277C	636B	2364	25406	093C	633E
277	9245	20959	241D	51DF	17374	26323	43DE	66D3	14820	21523	39E4	5413
278	8271	3568	204F	0DF0	16887	1784	41F7	06F8	2011	8569	07DB	2179
279	18684	26453	48FC	6755	9342	32150	247E	7D96	13549	9590	34ED	2576
280	8220	29421	201C	72ED	4110	30538	100E	774A	28339	22466	6EB3	57C2
281	6837	24555	1AB5	5FEB	23690	25033	5C8A	61C9	25759	12455	649F	30A7
282	9613	10779	258D	2A1B	17174	23345	4316	5B31	11116	27506	2B6C	6B72
283	31632	25260	7B90	62AC	15816	12630	3DC8	3156	31448	21847	7AD8	5557
284	27448	16084	6B38	3ED4	13724	8042	359C	1F6A	27936	28392	6D20	6EE8
285	12417	26028	3081	65AC	18832	13014	4990	32D6	3578	1969	0DFA	07B1
286	30901	29852	78B5	749C	28042	14926	6D8A	3A4E	12371	30715	3053	77FB
287	9366	14978	2496	3A82	4683	7489	124B	1D41	12721	23674	31B1	5C7A
288	12225	12182	2FC1	2F96	17968	6091	4630	17CB	10264	22629	2818	5865
289	21458	25143	53D2	6237	10729	32551	29E9	7F27	25344	12857	6300	3239
290	6466	15838	1942	3DDE	3233	7919	0CA1	1EEF	13246	30182	33BE	75E6
291	8999	5336	2327	14D8	16451	2668	4043	0A6C	544	21880	0220	5578
292	26718	21885	685E	557D	13359	25730	342F	6482	9914	6617	26BA	19D9
293	3230	20561	0C9E	5051	1615	26132	064F	6614	4601	27707	11F9	6C3B
294	27961	30097	6D39	7591	26444	29940	674C	74F4	16234	16249	3F6A	3F79
295	28465	21877	6F31	5575	26184	25734	6648	6486	24475	24754	5F9B	60B2
296	6791	23589	1A87	5C25	23699	24622	5C93	602E	26318	31609	66CE	7B79
297	17338	26060	43BA	65CC	8669	13030	21DD	32E6	6224	22689	1850	58A1
298	11832	9964	2E38	26EC	5916	4982	171C	1376	13381	3226	3445	0C9A
299	11407	25959	2C8F	6567	18327	31887	4797	7C8F	30013	4167	753D	1047
300	15553	3294	3CC1	0CDE	20400	1647	4FB0	066F	22195	25624	56B3	6418

... continued on next page

# Appendix E: PN Offset Programming Information – continued

**Table E-1: PnMaskI and PnMaskQ Values for PilotPn**

Pilot PN	14-Chip Delay				13-Chip Delay				0-Chip Delay			
	I (Dec.)	Q (Dec.)	I (Hex.)	Q (Hex.)	I (Dec.)	Q (Dec.)	I (Hex.)	Q (Hex.)	I (Dec.)	Q (Dec.)	I (Hex.)	Q (Hex.)
301	17418	30173	440A	75DD	8709	29906	2205	74D2	30380	10924	76AC	2AAC
302	14952	15515	3A68	3C9B	7476	20593	1D34	5071	15337	23096	3BE9	5A38
303	52	5371	0034	14FB	26	17473	001A	4441	10716	22683	29DC	589B
304	27254	10242	6A76	2802	13627	5121	353B	1401	13592	10955	3518	2ACB
305	15064	28052	3AD8	6D94	7532	14026	1D6C	36CA	2412	17117	096C	42DD
306	10942	14714	2ABE	397A	5471	7357	155F	1CBD	15453	15837	3C5D	3DD
307	377	19550	0179	4C5E	20844	9775	516C	262F	13810	22647	35F2	5877
308	14303	8866	37DF	22A2	19007	4433	4A3F	1151	12956	10700	329C	29CC
309	24427	15297	5F6B	3BC1	32357	21468	7E65	53DC	30538	30293	774A	7655
310	26629	10898	6805	2A92	26066	5449	65D2	1549	10814	5579	2A3E	15CB
311	20011	31315	4E2B	7A53	30405	29461	76C5	7315	18939	11057	49FB	2B31
312	16086	19475	3ED6	4C13	8043	26677	1F6B	6835	19767	30238	4D37	761E
313	24374	1278	5F36	04FE	12187	639	2F9B	027F	20547	14000	5043	36B0
314	9969	11431	26F1	2CA7	17064	22639	42A8	586F	29720	22860	7418	594C
315	29364	31392	72B4	7AA0	14682	15696	395A	3D50	31831	27172	7C57	6A24
316	25560	4381	63D8	111D	12780	18098	31EC	46B2	26287	307	66AF	0133
317	28281	14898	6E79	3A32	26348	7449	66EC	1D19	11310	20380	2C2E	4F9C
318	7327	23959	1C9F	5D97	24479	24823	5F9F	60F7	25724	26427	647C	673B
319	32449	16091	7EC1	3EDB	28336	20817	6EB0	5151	21423	10702	53AF	29CE
320	26334	9037	66DE	234D	13167	24474	336F	5F9A	5190	30024	1446	7548
321	14760	24162	39A8	5E62	7380	12081	1CD4	2F31	258	14018	0102	36C2
322	15128	6383	3B18	18EF	7564	16971	1D8C	424B	13978	4297	369A	10C9
323	29912	27183	74D8	6A2F	14956	31531	3A6C	7B2B	4670	13938	123E	3672
324	4244	16872	1094	41E8	2122	8436	084A	20F4	23496	25288	5BC8	62C8
325	8499	9072	2133	2370	16713	4536	4149	11B8	23986	27294	5DB2	6A9E
326	9362	12966	2492	32A6	4681	6483	1249	1953	839	31835	0347	7C5B
327	10175	28886	27BF	70D6	16911	14443	420F	386B	11296	8228	2C20	2024
328	30957	25118	78ED	621E	28070	12559	6DA6	310F	30913	12745	78C1	31C9
329	12755	20424	31D3	4FC8	18745	10212	4939	27E4	27297	6746	6AA1	1A5A
330	19350	6729	4B96	1A49	9675	17176	25CB	4318	10349	1456	286D	05B0
331	1153	20983	0481	51F7	21392	26311	5390	66C7	32504	27743	7EF8	6C5F
332	29304	12372	7278	3054	14652	6186	393C	182A	18405	27443	47E5	6B33
333	6041	13948	1799	367C	23068	6974	5A1C	1B3E	3526	31045	0DC6	7945
334	21668	27547	54A4	6B9B	10834	31729	2A52	7BF1	19161	12225	4AD9	2FC1
335	28048	8152	6D90	1FD8	14024	4076	36C8	0FEC	23831	21482	5D17	53EA
336	10096	17354	2770	43CA	5048	8677	13B8	21E5	21380	14678	5384	3956
337	23388	17835	5B5C	45AB	11694	27881	2DAE	6CE9	4282	30656	10BA	77C0
338	15542	14378	3CB6	382A	7771	7189	1E5B	1C15	32382	13721	7E7E	3599
339	24013	7453	5DCD	1D1D	32566	16562	7F36	40B2	806	21831	0326	5547
340	2684	26317	0A7C	66CD	1342	32090	053E	7D5A	6238	30208	185E	7600
341	19018	5955	4A4A	1743	9509	17821	2525	459D	10488	9995	28F8	270B
342	25501	10346	639D	286A	24606	5173	601E	1435	19507	3248	4C33	0CB0
343	4489	13200	1189	3390	22804	6600	5914	19C8	27288	12030	6A98	2EFE
344	31011	30402	7923	76C2	27969	15201	6D41	3B61	2390	5688	0956	1638
345	29448	7311	7308	1C8F	14724	16507	3984	407B	19094	2082	4A96	0822
346	25461	3082	6375	0C0A	24682	1541	606A	0605	13860	23143	3624	5A67
347	11846	21398	2E46	5396	5923	10699	1723	29CB	9225	25906	2409	6532
348	30331	31104	767B	7980	27373	15552	6AED	3CC0	2505	15902	09C9	3E1E
349	10588	24272	295C	5ED0	5294	12136	14AE	2F68	27806	21084	6C9E	525C
350	32154	27123	7D9A	69F3	16077	31429	3ECD	7AC5	2408	25723	0968	647B

... continued on next page

# Appendix E: PN Offset Programming Information – continued

**Table E-1: PnMaskI and PnMaskQ Values for PilotPn**

Pilot PN	14-Chip Delay				13-Chip Delay				0-Chip Delay			
	I (Dec.)	Q	I (Hex.)	Q	I (Dec.)	Q	I (Hex.)	Q	I (Dec.)	Q	I (Hex.)	Q
351	29572	5578	7384	15CA	14786	2789	39C2	0AE5	13347	13427	3423	3473
352	13173	25731	3375	6483	18538	31869	486A	7C7D	7885	31084	1ECD	796C
353	10735	10662	29EF	29A6	17703	5331	4527	14D3	6669	24023	1A0D	5DD7
354	224	11084	00E0	2B4C	112	5542	0070	15A6	8187	23931	1FFB	5D7B
355	12083	31098	2F33	797A	17993	15549	4649	3CBD	18145	15836	46E1	3DDC
356	22822	16408	5926	4018	11411	8204	2C93	200C	14109	6085	371D	17C5
357	2934	6362	0B76	18DA	1467	3181	05BB	0C6D	14231	30324	3797	7674
358	27692	2719	6C2C	0A9F	13846	19315	3616	4B73	27606	27561	6BD6	6BA9
359	10205	14732	27DD	398C	16958	7366	423E	1CC6	783	13821	030F	35FD
360	7011	22744	1B63	58D8	23649	11372	5C61	2C6C	6301	269	189D	010D
361	22098	1476	5652	05C4	11049	738	2B29	02E2	5067	28663	13CB	6FF7
362	2640	8445	0A50	20FD	1320	24130	0528	5E42	15383	29619	3C17	73B3
363	4408	21118	1138	527E	2204	10559	089C	293F	1392	2043	0570	07FB
364	102	22198	0066	56B6	51	11099	0033	2B5B	7641	6962	1DD9	1B32
365	27632	22030	6BF0	560E	13816	11015	35F8	2B07	25700	29119	6464	71BF
366	19646	10363	4CBE	287B	9823	23041	265F	5A01	25259	22947	62AB	59A3
367	26967	25802	6957	64CA	25979	12901	657B	3265	19813	9612	4D65	258C
368	32008	2496	7D08	09C0	16004	1248	3E84	04E0	20933	18698	51C5	490A
369	7873	31288	1EC1	7A38	24240	15644	5EB0	3D1C	638	16782	027E	418E
370	655	24248	028F	5EB8	20631	12124	5097	2F5C	16318	29735	3FBE	7427
371	25274	14327	62BA	37F7	12637	21959	315D	55C7	6878	2136	1ADE	0858
372	16210	23154	3F52	5A72	8105	11577	1FA9	2D39	1328	8086	0530	1F96
373	11631	13394	2D6F	3452	18279	6697	4767	1A29	14744	10553	3998	2939
374	8535	1806	2157	070E	16763	903	417B	0387	22800	11900	5910	2E7C
375	19293	17179	4B5D	431B	29822	28593	747E	6FB1	25919	19996	653F	4E1C
376	12110	10856	2F4E	2A68	6055	5428	17A7	1534	4795	5641	12BB	1609
377	21538	25755	5422	649B	10769	31857	2A11	7C71	18683	28328	48FB	6EA8
378	10579	15674	2953	3D3A	17785	7837	4579	1E9D	32658	25617	7F92	6411
379	13032	7083	32E8	1BAB	6516	17385	1974	43E9	1586	26986	0632	696A
380	14717	29096	397D	71A8	19822	14548	4D6E	38D4	27208	5597	6A48	15DD
381	11666	3038	2D92	0BDE	5833	1519	16C9	05EF	17517	14078	446D	36FE
382	25809	16277	64D1	3F95	25528	20982	63B8	51F6	599	13247	0257	33BF
383	5008	25525	1390	63B5	2504	32742	09C8	7FE6	16253	499	3F7D	01F3
384	32418	20465	7EA2	4FF1	16209	27076	3F51	69C4	8685	30469	21ED	7705
385	22175	28855	569F	70B7	31391	30311	7A9F	7667	29972	17544	7514	4488
386	11742	32732	2DDE	7FDC	5871	16366	16EF	3FEE	22128	28510	5670	6F5E
387	22546	20373	5812	4F95	11273	27126	2C09	69F6	19871	23196	4D9F	5A9C
388	21413	9469	53A5	24FD	30722	23618	7802	5C42	19405	13384	4BCD	3448
389	133	26155	0085	662B	20882	32041	5192	7D29	17972	4239	4634	108F
390	4915	6957	1333	1B2D	22601	17322	5849	43AA	8599	20725	2197	50F5
391	8736	12214	2220	2FB6	4368	6107	1110	17DB	10142	6466	279E	1942
392	1397	21479	0575	53E7	21354	26575	536A	67CF	26834	28465	68D2	6F31
393	18024	31914	4668	7CAA	9012	15957	2334	3E55	23710	19981	5C9E	4E0D
394	15532	32311	3CAC	7E37	7766	28967	1E56	7127	27280	16723	6A90	4153
395	26870	11276	68F6	2C0C	13435	5638	347B	1606	6570	4522	19AA	11AA
396	5904	20626	1710	5092	2952	10313	0B88	2849	7400	678	1CE8	02A6
397	24341	423	5F15	01A7	32346	20207	7E5A	4EEF	26374	15320	6706	3BD8
398	13041	2679	32F1	0A77	18600	19207	48A8	4B07	22218	29116	56CA	71BC
399	23478	15537	5BB6	3CB1	11739	20580	2DDB	5064	29654	5388	73D6	150C
400	1862	10818	0746	2A42	931	5409	03A3	1521	13043	22845	32F3	593D

... continued on next page

**Appendix E: PN Offset Programming Information – continued**

**Table E-1: PnMaskI and PnMaskQ Values for PilotPn**

Pilot PN	14-Chip Delay				13-Chip Delay				0-Chip Delay			
	I (Dec.)	Q	I (Hex.)	Q	I (Dec.)	Q	I (Hex.)	Q	I (Dec.)	Q	I (Hex.)	Q
401	5850	23074	16DA	5A22	2925	11537	0B6D	2D11	24457	28430	5F89	6F0E
402	5552	20250	15B0	4F1A	2776	10125	0AD8	278D	17161	8660	4309	21D4
403	12589	14629	312D	3925	18758	21166	4946	52AE	21314	2659	5342	0A63
404	23008	29175	59E0	71F7	11504	30407	2CF0	76C7	28728	8803	7038	2263
405	27636	13943	6BF4	3677	13818	21767	35FA	5507	22162	19690	5692	4CEA
406	17600	11072	44C0	2B40	8800	5536	2260	15A0	26259	22169	6693	5699
407	17000	29492	4268	7334	8500	14746	2134	399A	22180	8511	56A4	213F
408	21913	5719	5599	1657	31516	17687	7B1C	4517	2266	17393	08DA	43F1
409	30320	7347	7670	1CB3	15160	16485	3B38	4065	10291	11336	2833	2C48
410	28240	12156	6E50	2F7C	14120	6078	3728	17BE	26620	13576	67FC	3508
411	7260	25623	1C5C	6417	3630	31799	0E2E	7C37	19650	22820	4CC2	5924
412	17906	27725	45F2	6C4D	8953	30746	22F9	781A	14236	13344	379C	3420
413	5882	28870	16FA	70C6	2941	14435	0B7D	3863	11482	20107	2CDA	4E8B
414	22080	31478	5640	7AF6	11040	15739	2B20	3D7B	25289	8013	62C9	1F4D
415	12183	28530	2F97	6F72	17947	14265	461B	37B9	12011	18835	2EEB	4993
416	23082	24834	5A2A	6102	11541	12417	2D15	3081	13892	16793	3644	4199
417	17435	9075	441B	2373	29661	24453	73DD	5F85	17336	9818	43B8	265A
418	18527	32265	485F	7E09	30207	28984	75FF	7138	10759	4673	2A07	1241
419	31902	3175	7C9E	0C67	15951	18447	3E4F	480F	26816	13609	68C0	3529
420	18783	17434	495F	441A	30079	8717	757F	220D	31065	10054	7959	2746
421	20027	12178	4E3B	2F92	30413	6089	76CD	17C9	8578	10988	2182	2AEC
422	7982	25613	1F2E	640D	3991	31802	0F97	7C3A	24023	14744	5DD7	3998
423	20587	31692	506B	7BCC	31205	15846	79E5	3DE6	16199	17930	3F47	460A
424	10004	25384	2714	6328	5002	12692	138A	3194	22310	25452	5726	636C
425	13459	18908	3493	49DC	19353	9454	4B99	24EE	30402	11334	76C2	2C46
426	13383	25816	3447	64D8	19443	12908	4BF3	326C	16613	15451	40E5	3C5B
427	28930	4661	7102	1235	14465	18214	3881	4726	13084	11362	331C	2C62
428	4860	31115	12FC	798B	2430	29433	097E	72F9	3437	2993	0D6D	0BB1
429	13108	7691	3334	1E0B	6554	16697	199A	4139	1703	11012	06A7	2B04
430	24161	1311	5E61	051F	32480	19635	7EE0	4CB3	22659	5806	5883	16AE
431	20067	16471	4E63	4057	30433	28183	76E1	6E17	26896	20180	6910	4ED4
432	2667	15771	0A6B	3D9B	21733	20721	54E5	50F1	1735	8932	06C7	22E4
433	13372	16112	343C	3EF0	6686	8056	1A1E	1F78	16178	23878	3F32	5D46
434	28743	21062	7047	5246	27123	10531	69F3	2923	19166	20760	4ADE	5118
435	24489	29690	5FA9	73FA	32260	14845	7E04	39FD	665	32764	0299	7FFC
436	249	10141	00F9	279D	20908	24050	51AC	5DF2	20227	32325	4F03	7E45
437	19960	19014	4DF8	4A46	9980	9507	26FC	2523	24447	25993	5F7F	6589
438	29682	22141	73F2	567D	14841	25858	39F9	6502	16771	3268	4183	0CC4
439	31101	11852	797D	2E4C	28014	5926	6D6E	1726	27209	25180	6A49	625C
440	27148	26404	6A0C	6724	13574	13202	3506	3392	6050	12149	17A2	2F75
441	26706	30663	6852	77C7	13353	30175	3429	75DF	29088	10193	71A0	27D1
442	5148	32524	141C	7F0C	2574	16262	0A0E	3F86	7601	9128	1DB1	23A8
443	4216	28644	1078	6FE4	2108	14322	083C	37F2	4905	7843	1329	1EA3
444	5762	10228	1682	27F4	2881	5114	0B41	13FA	5915	25474	171B	6382
445	245	23536	00F5	5BF0	20906	11768	51AA	2DF8	6169	11356	1819	235C
446	21882	18045	557A	467D	10941	27906	2ABD	6D02	21303	11226	5337	2BDA
447	3763	25441	0EB3	6361	22153	32652	5689	7F8C	28096	16268	6DC0	3F8C
448	206	27066	00CE	69BA	103	13533	0067	34DD	8905	14491	22C9	389B
449	28798	13740	707E	35AC	14399	6870	383F	1AD6	26997	8366	6975	20AE
450	32402	13815	7E92	35F7	16201	21703	3F49	54C7	15047	26009	3AC7	6599

... continued on next page



# Appendix E: PN Offset Programming Information – continued

**Table E-1: PnMaskI and PnMaskQ Values for PilotPn**

Pilot PN	14-Chip Delay				13-Chip Delay				0-Chip Delay			
	I (Dec.)	Q (Dec.)	I (Hex.)	Q (Hex.)	I (Dec.)	Q (Dec.)	I (Hex.)	Q (Hex.)	I (Dec.)	Q (Dec.)	I (Hex.)	Q (Hex.)
451	13463	3684	3497	0E64	19355	1842	4B9B	0732	17460	5164	4434	142C
452	15417	23715	3C39	5CA3	20428	24685	4FCC	606D	17629	17126	44DD	42E6
453	23101	15314	5A3D	3BD2	31950	7657	7CCE	1DE9	10461	21566	28DD	543E
454	14957	32469	3A6D	7ED5	19686	29014	4CE6	7156	21618	21845	5472	5555
455	23429	9816	5B85	2658	31762	4908	7C12	132C	11498	28149	2CEA	6DF5
456	12990	4444	32BE	115C	6495	2222	195F	08AE	193	9400	00C1	24B8
457	12421	5664	3085	1620	18834	2832	4992	0B10	16140	19459	3F0C	4C03
458	28875	7358	70CB	1CBE	27061	3679	69B5	0E5F	13419	7190	346B	1C16
459	4009	27264	0FA9	6A80	22020	13632	5604	3540	10864	3101	2A70	0C1D
460	1872	28128	0750	6DE0	936	14064	03A8	36F0	28935	491	7107	01EB
461	15203	30168	3B63	75D8	19553	15084	4C61	3AEC	18765	25497	494D	6399
462	30109	29971	759D	7513	27422	29877	6B1E	74B5	27644	29807	6BFC	746F
463	24001	3409	5DC1	0D51	32560	18580	7F30	4894	21564	26508	543C	678C
464	4862	16910	12FE	420E	2431	8455	097F	2107	5142	4442	1416	115A
465	14091	20739	370B	5103	19029	26301	4A55	66BD	1211	4871	04BB	1307
466	6702	10191	1A2E	27CF	3351	24027	0D17	5DDB	1203	31141	04B3	79A5
467	3067	12819	0BFB	3213	21549	22325	542D	5735	5199	9864	144F	2688
468	28643	19295	6FE3	4B5F	26145	27539	6621	6B93	16945	12589	4231	312D
469	21379	10072	5383	2758	30737	5036	7811	13AC	4883	5417	1313	1529
470	20276	15191	4F34	3B57	10138	21399	279A	5397	25040	8549	61D0	2165
471	25337	27748	62F9	6C64	24748	13874	60AC	3632	7119	14288	1BCF	37D0
472	19683	720	4CE3	02D0	30625	360	77A1	0168	17826	8503	45A2	2137
473	10147	29799	27A3	7467	16897	29711	4201	740F	4931	20357	1343	4F85
474	16791	27640	4197	6BF8	28955	13820	711B	35FC	25705	15381	6469	3C15
475	17359	263	43CF	0107	28727	20159	7037	4EBF	10726	18065	29E6	4691
476	13248	24734	33C0	609E	6624	12367	19E0	304F	17363	24678	43D3	6066
477	22740	16615	58D4	40E7	11370	28239	2C6A	6E4F	2746	23858	0ABA	5D32
478	13095	20378	3327	4F9A	18499	10189	4843	27CD	10952	7610	2AC8	1DBA
479	10345	25116	2869	621C	17892	12558	45E4	310E	19313	18097	4B71	46B1
480	30342	19669	7686	4CD5	15171	26710	3B43	6856	29756	20918	743C	51B6
481	27866	14656	6CDA	3940	13933	7328	366D	1CA0	14297	7238	37D9	1C46
482	9559	27151	2557	6A0F	17275	31547	437B	7B3B	21290	30549	532A	7755
483	8808	28728	2268	7038	4404	14364	1134	381C	1909	16320	0775	3FC0
484	12744	25092	31C8	6204	6372	12546	18E4	3102	8994	20853	2322	5175
485	11618	22601	2D62	5849	5809	25112	16B1	6218	13295	26736	33EF	6870
486	27162	2471	6A1A	09A7	13581	19183	350D	4AEF	21590	10327	5456	2857
487	17899	25309	45EB	62DD	29477	32594	7325	7F52	26468	24404	6764	5F54
488	29745	15358	7431	3BFE	27592	7679	6BC8	1DFF	13636	7931	3544	1EFB
489	31892	17739	7C94	454B	15946	27801	3E4A	6C99	5207	5310	1457	14BE
490	23964	12643	5D9C	3163	11982	22157	2ECE	568D	29493	554	7335	022A
491	23562	32730	5C0A	7FDA	11781	16365	2E05	3FED	18992	27311	4A30	6AAF
492	2964	19122	0B94	4AB2	1482	9561	05CA	2559	12567	6865	3117	1AD1
493	18208	16870	4720	41E6	9104	8435	2390	20F3	12075	7762	2F2B	1E52
494	15028	10787	3AB4	2A23	7514	23341	1D5A	5B2D	26658	15761	6822	3D91
495	21901	18400	558D	47E0	31510	9200	7B16	23F0	21077	12697	5255	3199
496	24566	20295	5FF6	4F47	12283	27039	2FFB	699F	15595	24850	3CEB	6112
497	18994	1937	4A32	0791	9497	19956	2519	4DF4	4921	15259	1339	3B9B
498	13608	17963	3528	462B	6804	27945	1A94	6D29	14051	24243	36E3	5EB3
499	27492	7438	6B64	1D0E	13746	3719	35B2	0E87	5956	30508	1744	772C
500	11706	12938	2DBA	328A	5853	6469	16DD	1945	21202	13982	52D2	369E

... continued on next page

## Appendix E: PN Offset Programming Information – continued

**Table E-1: PnMaskI and PnMaskQ Values for PilotPn**

Pilot PN	14-Chip Delay		13-Chip Delay		12-Chip Delay		11-Chip Delay		10-Chip Delay		9-Chip Delay		8-Chip Delay		7-Chip Delay		6-Chip Delay		5-Chip Delay		4-Chip Delay		3-Chip Delay		2-Chip Delay		0-Chip Delay									
	I (Dec.)	Q	I (Hex.)	Q	I (Dec.)	Q	I (Hex.)	Q	I (Dec.)	Q	I (Hex.)	Q	I (Dec.)	Q	I (Hex.)	Q	I (Dec.)	Q	I (Hex.)	Q	I (Dec.)	Q	I (Hex.)	Q	I (Dec.)	Q	I (Hex.)	Q	I (Dec.)	Q	I (Hex.)	Q	I (Dec.)	Q	I (Hex.)	
501	14301	19272	37DD	4B48	19006	9636	4A3E	25A4	11239	25039	2BE7	61CF	11239	25039	2BE7	61CF	11239	25039	2BE7	61CF	11239	25039	2BE7	61CF	11239	25039	2BE7	61CF	11239	25039	2BE7	61CF	11239	25039	2BE7	61CF
502	23380	29989	5B54	7525	11690	29870	2DAA	74AE	30038	24086	7556	5E16	30038	24086	7556	5E16	30038	24086	7556	5E16	30038	24086	7556	5E16	30038	24086	7556	5E16	30038	24086	7556	5E16	30038	24086	7556	5E16
503	11338	8526	2C4A	214E	5669	4263	1625	10A7	30222	21581	760E	544D	30222	21581	760E	544D	30222	21581	760E	544D	30222	21581	760E	544D	30222	21581	760E	544D	30222	21581	760E	544D	30222	21581	760E	544D
504	2995	18139	0BB3	46DB	21513	27985	5409	6D51	13476	21346	34A4	5362	13476	21346	34A4	5362	13476	21346	34A4	5362	13476	21346	34A4	5362	13476	21346	34A4	5362	13476	21346	34A4	5362	13476	21346	34A4	5362
505	23390	3247	5B5E	0CAF	11695	18539	2DAF	486B	2497	28187	09C1	6E1B	2497	28187	09C1	6E1B	2497	28187	09C1	6E1B	2497	28187	09C1	6E1B	2497	28187	09C1	6E1B	2497	28187	09C1	6E1B	2497	28187	09C1	6E1B
506	14473	28919	3889	70F7	19860	30279	4D94	7647	31842	23231	7C62	5ABF	31842	23231	7C62	5ABF	31842	23231	7C62	5ABF	31842	23231	7C62	5ABF	31842	23231	7C62	5ABF	31842	23231	7C62	5ABF	31842	23231	7C62	5ABF
507	6530	7292	1982	1C7C	3265	3646	0CC1	0E3E	24342	18743	5F16	4937	24342	18743	5F16	4937	24342	18743	5F16	4937	24342	18743	5F16	4937	24342	18743	5F16	4937	24342	18743	5F16	4937	24342	18743	5F16	4937
508	20452	20740	4FE4	5104	10226	10370	27F2	2882	25857	11594	6501	2D4A	25857	11594	6501	2D4A	25857	11594	6501	2D4A	25857	11594	6501	2D4A	25857	11594	6501	2D4A	25857	11594	6501	2D4A	25857	11594	6501	2D4A
509	12226	27994	2FC2	6D5A	6113	13997	17E1	36AD	27662	7198	6C0E	1C1E	27662	7198	6C0E	1C1E	27662	7198	6C0E	1C1E	27662	7198	6C0E	1C1E	27662	7198	6C0E	1C1E	27662	7198	6C0E	1C1E	27662	7198	6C0E	1C1E
510	1058	2224	0422	08B0	529	1112	0211	0458	24594	105	6012	0069	24594	105	6012	0069	24594	105	6012	0069	24594	105	6012	0069	24594	105	6012	0069	24594	105	6012	0069	24594	105	6012	0069
511	12026	6827	2EFA	1AAB	6013	17257	177D	4369	16790	4534	4196	11B6	16790	4534	4196	11B6	16790	4534	4196	11B6	16790	4534	4196	11B6	16790	4534	4196	11B6	16790	4534	4196	11B6	16790	4534	4196	11B6

E





# Appendix F: Test Equipment Preparation

## Appendix Content

---

Test Equipment Preparation .....	F-1
Purpose .....	F-1
HP8921A Test Equipment Connections .....	F-1
HP8921A System Connectivity Test .....	F-5
Setting HP8921A and HP83236A/B GPIB Address .....	F-6
Pretest Setup for HP8921A .....	F-6
Pretest Setup for HP8935 .....	F-6
Advantest R3465 Connection .....	F-7
R3465 GPIB Address & Clock setup .....	F-9
Pretest Setup for Advantest R3465 .....	F-9
Manual Cable Calibration .....	F-10
Calibrating Test Cable Setup using HP PCS Interface (HP83236) .....	F-10
Calibrating Test Cable Setup using Advantest R3465 .....	F-14
Calibrating HP 437 Power Meter .....	F-17
Calibrating Gigatronics 8542 power meter .....	F-19





# Test Equipment Preparation

## Purpose

This appendix provides information on setting up the HP8921 with PCS interface, the HP8935 and the Advantest R3465. The Cybertest test set doesn't require any setup.

## HP8921A Test Equipment Connections

The following diagram depicts the rear panels of the HP 8921A test equipment as configured to perform automatic tests. All test equipment is controlled by the LMF via an IEEE-488/GPIB bus. The LMF expects each piece of test equipment to have a factory-set GPIB address (refer to Table F-4). If there is a communications problem between the LMF and any piece of test equipment, you should verify that the GPIB addresses have been set correctly and that the GPIB cables are firmly connected to the test equipment.

Figure F-1 shows the connections when **not using** an external 10 MHz Rubidium reference.

**Table F-1:** HP8921A/600 Communications Test Set Rear Panel Connections Without Rubidium Reference

From Test Set:	To Interface:		Connector Type
	8921A	83203B CDMA	
CW RF OUT	CW RF IN		SMC-female – SMC-female
114.3 MHZ IF OUT	114.3 MHZ IF IN		SMC-female – SMC-female
IQ RF IN	IQ RF OUT		SMC-female – SMC-female
DET OUT	AUX DSP IN		SMC-female – SMC-female
CONTROL I/O	CONTROL I/O		45-pin custom BUS
10 MHZ OUT	SYNTH REF IN		BNC-male – BNC-male
HPIB INTERFACE		HPIB INTERFACE	HPIB cable
	10 MHZ OUT	REF IN	BNC-male – BNC-male

F

# Test Equipment Preparation – continued

**Figure F-1: HP8921A/600 Cables Connection for 10 MHz Signal and GPIB without Rubidium Reference**

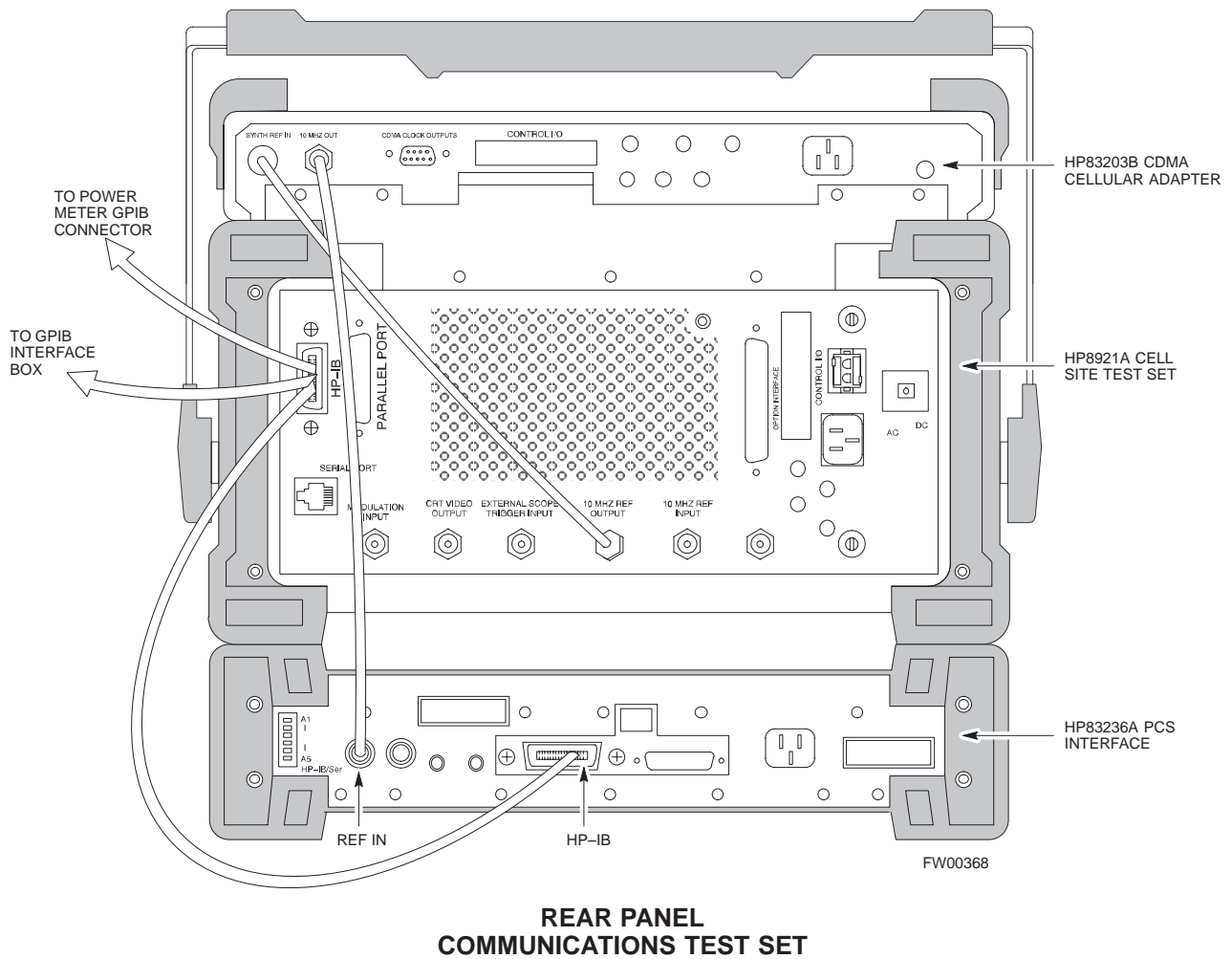

F

## Test Equipment Preparation – continued

Figure F-2 shows the connections **when using** an external 10 MHz Rubidium reference.

<b>Table F-2: HP8921A/600 Communications Test Set Rear Panel Connections With Rubidium Reference</b>			
<b>From Test Set:</b>	<b>To Interface:</b>		<b>Connector Type</b>
<b>8921A</b>	<b>83203B CDMA</b>	<b>83236A PCS</b>	
CW RF OUT	CW RF IN		SMC–female – SMC–female
114.3 MHZ IF OUT	114.3 MHZ IF IN		SMC–female – SMC–female
IQ RF IN	IQ RF OUT		SMC–female – SMC–female
DET OUT	AUX DSP IN		SMC–female – SMC–female
CONTROL I/O	CONTROL I/O		45–pin custom BUS
10 MHZ OUT		REF IN	BNC–male – BNC–male
HPIB INTERFACE		HPIB INTERFACE	HPIB cable
10 MHZ INPUT	10 MHZ OUT		BNC–male – BNC–male

Figure F-2: HP8921A Cables Connection for 10 MHz Signal and GPIB with Rubidium Reference

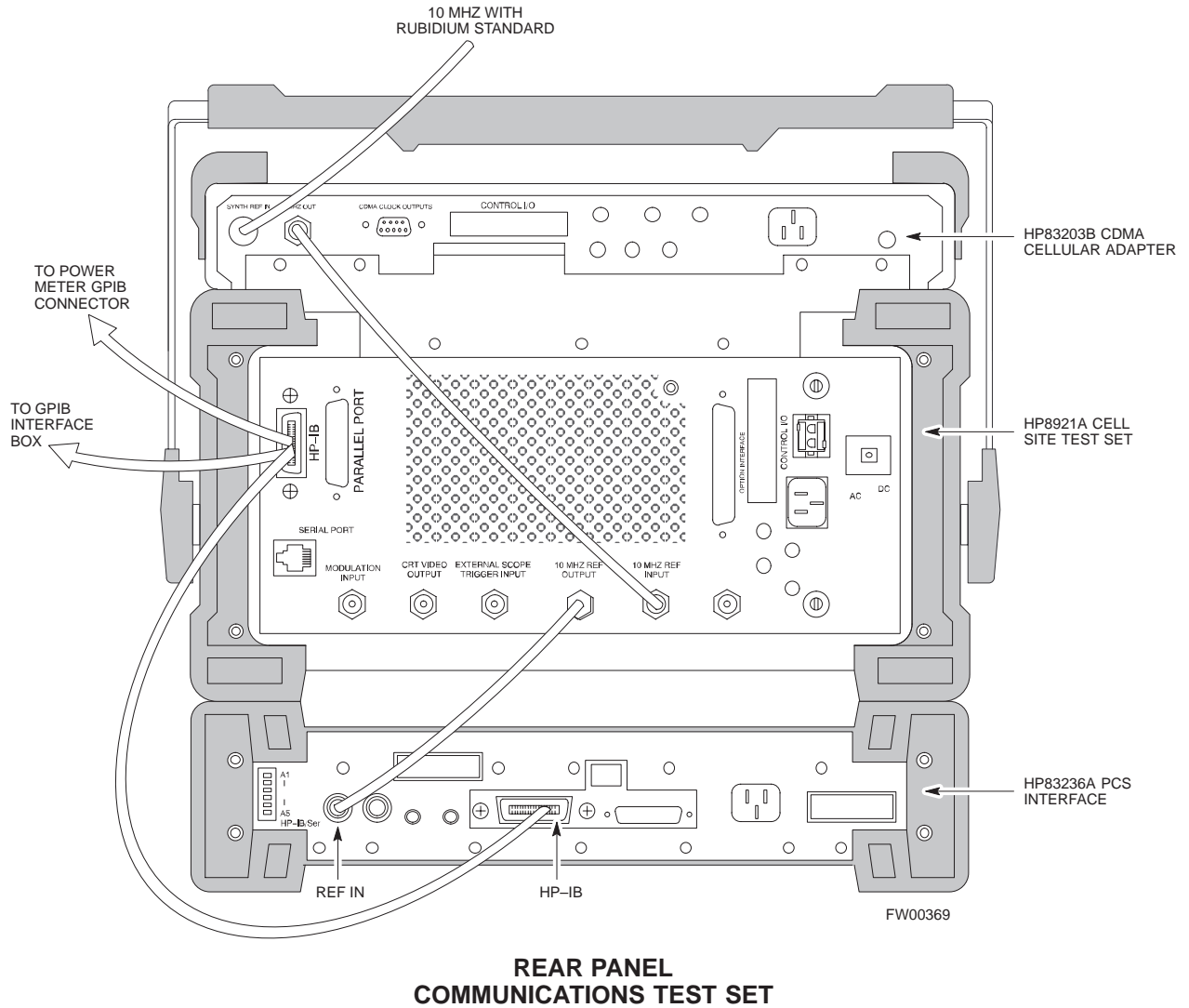

F

## Test Equipment Preparation – continued

### HP8921A System Connectivity Test

Follow the steps outlined in Table F-3 to verify that the connections between the PCS Interface and the HP8921A are correct and cables are intact. The software also performs basic functionality checks of each instrument.



#### IMPORTANT

Disconnect other GPIB devices, especially system controllers, from the system before running the connectivity software.

**Table F-3: System Connectivity**

Step	Action
	<b>* IMPORTANT</b> – Perform this procedure <i>after</i> test equipment has been allowed to warm-up and stabilize for a <i>minimum of 60 minutes</i> .
1	Insert HP 83236A Manual Control/System card into memory card slot.
2	Press the [PRESET] pushbutton.
3	Press the Screen Control [TESTS] pushbutton to display the “Tests” Main Menu screen.
4	Position the cursor at <b>Select Procedure Location</b> and select it by pressing the cursor control knob. In the Choices selection box, select <b>Card</b> .
5	Position the cursor at <b>Select Procedure Filename</b> and select it by pressing the cursor control knob. In the Choices selection box, select <b>SYS_CONN</b> .
6	Position the cursor at <b>RUN TEST</b> and select it. The software will prompt you through the connectivity setup.
7	Do the following when the test is complete, <ul style="list-style-type: none"><li>• position cursor on <b>STOP TEST</b> and select it</li><li>• OR press the [K5] pushbutton.</li></ul>
8	To return to the main menu, press the [K5] pushbutton.
9	Press the [PRESET] pushbutton.

## Test Equipment Preparation – continued

### Setting HP8921A and HP83236A/B GPIB Address

**Table F-4:** Setting HP8921A GPIB Address

Step	Action
1	If you have not already done so, turn the HP8921A power on.
2	Verify that the GPIB addresses are set correctly. <ul style="list-style-type: none"><li>• HP8921A HP-IB Adrs = 18, accessed by pushing <b>LOCAL</b> and selecting <b>More</b> and <b>I/O Configure</b> on the HP8921A/600. (Consult test equipment OEM documentation for additional info as required).</li><li>• HP83236A (or B) PCS Interface GPIB address=19. Set dip switches as follows:<ul style="list-style-type: none"><li>– A1=1, A2=1, A3=0, A4=0, A5=1, HP-IB/Ser = 1</li></ul></li></ul>

### Pretest Setup for HP8921A

Before the HP8921A CDMA analyzer is used for LMF controlled testing it must be set up correctly for automatic testing.

**Table F-5:** Pretest Setup for HP8921A

Step	Action
1	Unplug the memory card if it is plugged in.
2	Press the <b>CURSOR CONTROL</b> knob.
3	Position the cursor at <b>IO CONFIG</b> (under <b>To Screen</b> and <b>More</b> ) and select it.
4	Select Mode and set for <b>Talk&amp;Lstn</b> .

### Pretest Setup for HP8935

Before the HP8935 CDMA analyzer is used for LMF controlled testing it must be set up correctly for automatic testing.

**Table F-6:** Pretest Setup for HP8935

Step	Action
1	Unplug the memory card if it is plugged in.
2	Press the <b>Shift</b> button and then press the <b>I/O Config</b> button.
3	Press the <b>Push to Select</b> knob.
4	Position the cursor at <b>IO CONFIG</b> and select it.
5	Select <b>Mode</b> and set for <b>Talk&amp;Lstn</b> .



Advantest R3465 Connection

The following diagram depicts the rear panels of the Advantest test equipment as configured to perform automatic tests. All test equipment is controlled by the LMF via an IEEE-488/GPIB bus. The LMF expects each piece of test equipment to have a factory-set GPIB address (refer to Table F-7). If there is a communications problem between the LMF and any piece of test equipment, you should verify that the GPIB addresses have been set correctly and that the GPIB cables are firmly connected to the test equipment.

Figure F-3 shows the connections when **not using** an external 10 MHz Rubidium reference.

Figure F-3: Cable Connections for Test Set without 10 MHz Rubidium Reference

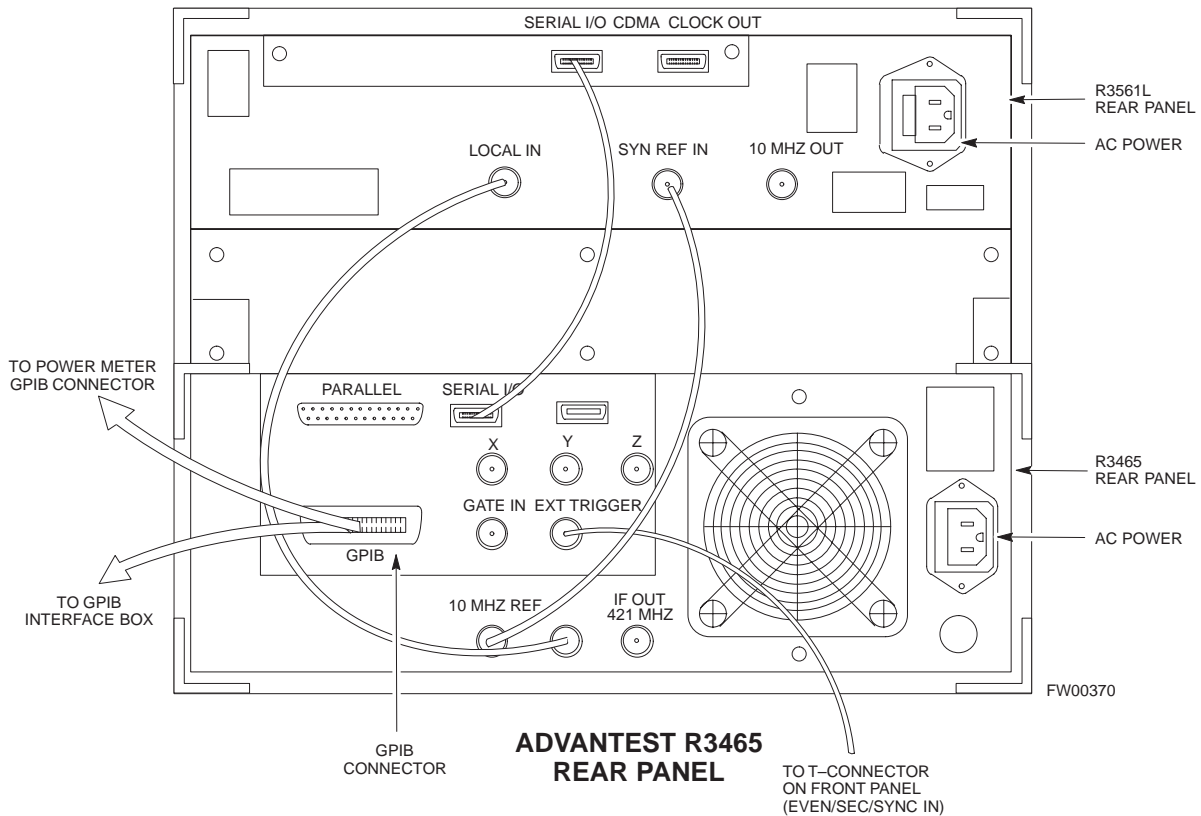

F

# Test Equipment Preparation – continued

Figure F-4 shows the connections when **using** an external 10 MHz Rubidium reference.

**Figure F-4:** Cable Connections for Test Set with 10 MHz Rubidium Reference

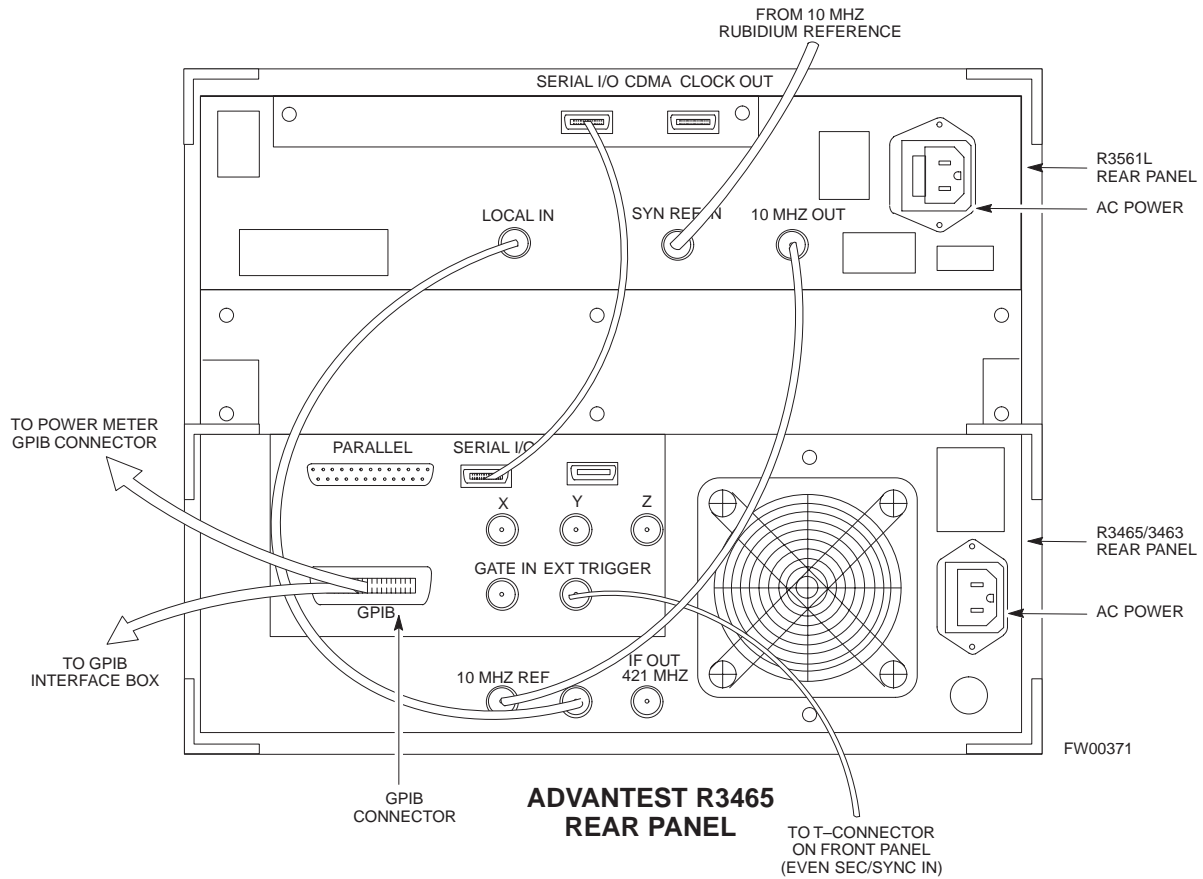

F

## Test Equipment Preparation – continued

### R3465 GPIB Address & Clock setup

Table F-7 describes the steps to set the GPIB address and clock for the **Advantest** R3465 equipment.

Table F-7: Advantest R3465 GPIB Address and Clock Setup	
Step	Action
1	<p>Communications test set GPIB address=<b>18</b> (<i>perform the following to view/set as required</i>)</p> <p>Perform the following to set the standard parameters on the test set:</p> <ul style="list-style-type: none"> <li>• Push the <b>SHIFT</b> then <b>PRESET</b> pushbutton (just below the CRT display).</li> <li>• Push the <b>LCL</b> pushbutton (CW in Measurement just below the CRT display) <ul style="list-style-type: none"> <li>– Push the <b>GPIB and Others</b> CRT menu key to view the current address.</li> <li>– <i>If required</i>, change GPIB address to <b>18</b> (<i>rotate the vernier knob to set, push the vernier knob to enter</i>)</li> </ul> </li> </ul>
2	<p>Verify the current Date and Time in upper/right of the CRT display (<i>perform the following to set if required</i>)</p> <p>Communications test set GPIB address=<b>18</b> (<i>perform the following to view/set as required</i>)</p> <ul style="list-style-type: none"> <li>• Push the <b>Date/Time CRT</b> menu key</li> <li>• <i>If required</i>, change to correct Date/Time (<i>rotate the vernier knob to select and set, push the vernier knob to enter</i>)</li> <li>• Push the <b>SHIFT</b> then <b>PRESET</b> pushbutton (just below the CRT display).</li> </ul>

### Pretest Setup for Advantest R3465

Before the Advantest R3465 analyzer is used for LMF controlled testing it must be set up correctly for automatic testing.

Table F-8: Pretest Setup for Advantest R346	
Step	Action
1	Press the <b>SHIFT</b> button so the LED next to it is illuminated.
2	Press the <b>RESET</b> button.

# Manual Cable Calibration

## Calibrating Test Cable Setup using HP PCS Interface (HP83236)

Table F-9 covers the procedure to calibrate the test equipment using the HP8921 Cellular Communications Analyzer equipped with the HP83236 PCS Interface.

### NOTE

This calibration method *must be executed with great care*. Some losses are measured close to the minimum limit of the power meter sensor (−30 dBm).

### Prerequisites

Ensure the following prerequisites have been met before proceeding:

- Test equipment to be calibrated has been connected correctly for cable calibration.
- Test equipment has been selected and calibrated.

**Table F-9:** Calibrating Test Cable Setup (using the HP PCS Interface)

Step	Action		
	<b>NOTE</b> Verify that GPIB controller is turned off.		
1	Insert HP83236 Manual Control System card into memory card slot.		
2	Press the <b>Preset</b> pushbutton.		
3	Under <b>Screen Controls</b> , press the <b>TESTS</b> pushbutton to display the <b>TESTS (Main Menu)</b> screen.		
4	Position the cursor at <b>Select Procedure Location</b> and select it. In the Choices selection box, select <b>CARD</b> .		
5	Position the cursor at <b>Select Procedure Filename</b> and select it. In the Choices selection box, select <b>MANUAL</b> .		
6	Position the cursor at <b>RUN TEST</b> and select it. HP must be in Control Mode <b>Select YES</b> .		
7	<table border="0" style="width: 100%;"> <tr> <td style="width: 50%; vertical-align: top;"> <p><b>If using HP 83236A:</b> Set channel number=&lt;chan#&gt;:</p> <ul style="list-style-type: none"> <li>– Position cursor at <b>Channel Number</b> and select it.</li> <li>– Enter the <i>chan#</i> using the numeric keypad; press [<b>Enter</b>] and the screen will go blank.</li> <li>– When the screen reappears, the <i>chan#</i> will be displayed on the channel number line.</li> </ul> </td> <td style="width: 50%; vertical-align: top;"> <p><b>If using HP 83236B:</b> Set channel frequency:</p> <ul style="list-style-type: none"> <li>– Position cursor at <b>Frequency Band</b> and press <b>Enter</b>.</li> <li>– Select <b>User Defined Frequency</b>.</li> <li>– <b>Go Back to Previous Menu</b>.</li> <li>– Position the cursor to <b>83236</b> generator frequency and enter actual RX frequency.</li> <li>– Position the cursor to <b>83236</b> analyzer frequency and enter actual TX frequency.</li> </ul> </td> </tr> </table>	<p><b>If using HP 83236A:</b> Set channel number=&lt;chan#&gt;:</p> <ul style="list-style-type: none"> <li>– Position cursor at <b>Channel Number</b> and select it.</li> <li>– Enter the <i>chan#</i> using the numeric keypad; press [<b>Enter</b>] and the screen will go blank.</li> <li>– When the screen reappears, the <i>chan#</i> will be displayed on the channel number line.</li> </ul>	<p><b>If using HP 83236B:</b> Set channel frequency:</p> <ul style="list-style-type: none"> <li>– Position cursor at <b>Frequency Band</b> and press <b>Enter</b>.</li> <li>– Select <b>User Defined Frequency</b>.</li> <li>– <b>Go Back to Previous Menu</b>.</li> <li>– Position the cursor to <b>83236</b> generator frequency and enter actual RX frequency.</li> <li>– Position the cursor to <b>83236</b> analyzer frequency and enter actual TX frequency.</li> </ul>
<p><b>If using HP 83236A:</b> Set channel number=&lt;chan#&gt;:</p> <ul style="list-style-type: none"> <li>– Position cursor at <b>Channel Number</b> and select it.</li> <li>– Enter the <i>chan#</i> using the numeric keypad; press [<b>Enter</b>] and the screen will go blank.</li> <li>– When the screen reappears, the <i>chan#</i> will be displayed on the channel number line.</li> </ul>	<p><b>If using HP 83236B:</b> Set channel frequency:</p> <ul style="list-style-type: none"> <li>– Position cursor at <b>Frequency Band</b> and press <b>Enter</b>.</li> <li>– Select <b>User Defined Frequency</b>.</li> <li>– <b>Go Back to Previous Menu</b>.</li> <li>– Position the cursor to <b>83236</b> generator frequency and enter actual RX frequency.</li> <li>– Position the cursor to <b>83236</b> analyzer frequency and enter actual TX frequency.</li> </ul>		

. . . continued on next page



## Manual Test Cable Setup – continued

**Table F-9:** Calibrating Test Cable Setup (using the HP PCS Interface)

Step	Action									
8	Set RF Generator level: <ul style="list-style-type: none"> <li>– Position the cursor at <b>RF Generator Level</b> and select it.</li> <li>– Enter <b>–10</b> using the numeric keypad; press [<b>Enter</b>] and the screen will go blank.</li> <li>– When the screen reappears, the value <b>–10 dBm</b> will be displayed on the RF Generator Level line.</li> </ul>									
9	Set the user fixed Attenuation Setting to <b>0 dBm</b> : <ul style="list-style-type: none"> <li>– Position cursor at <b>Analyzer Attenuation</b> and select it</li> <li>– Position cursor at <b>User Fixed Atten Settings</b> and select it.</li> <li>– Enter 0 (zero) using the numeric keypad and press [<b>Enter</b>].</li> </ul>									
10	Select <b>Back to Previous Menu</b> .									
11	Record the HP83236 Generator Frequency Level: Record the HP83236B Generator Frequency Level: <ul style="list-style-type: none"> <li>– Position cursor at <b>Show Frequency and Level Details</b> and select it.</li> <li>– Under HP83236 Frequencies and Levels, record the Generator Level.</li> <li>– Under HP83236B Frequencies and Levels, record the Generator Frequency Level (1850 – 1910 MHz).</li> <li>– Position cursor at <b>Prev Menu</b> and select it.</li> </ul>									
12	Click on <b>Pause for Manual Measurement</b> .									
13	Connect the power sensor directly to the <i>RF OUT ONLY</i> port of the PCS Interface.									
14	On the HP8921A, under <b>To Screen</b> , select <b>CDMA GEN</b> .									
15	Move the cursor to the <b>Amplitude</b> field and click on the Amplitude value.									
16	Increase the Amplitude value until the power meter reads <b>0 dBm ±0.2 dB</b> .  <b>NOTE</b> The Amplitude value can be increased coarsely until 0 dBm is reached; then fine tune the amplitude by adjusting the <b>Increment Set</b> to 0.1 dBm and targeting in on 0 dBm.									
17	Disconnect the power sensor from the <i>RF OUT ONLY</i> port of the PCS Interface.  <b>* IMPORTANT</b> The Power Meter sensor’s lower limit is –30 dBm. Thus, only components having losses ≤30 dB should be measured using this method. <b>For further accuracy, always re-zero the power meter before connecting the power sensor to the component being calibrated. After connecting the power sensor to the component, record the calibrated loss immediately.</b>									
18	Disconnect all components in the test setup and calibrate each one separately by connecting each component, one-at-a-time, between the <i>RF OUT ONLY PORT</i> and the power sensor. Record the calibrated loss value displayed on the power meter. <ul style="list-style-type: none"> <li>• Example:               <table style="margin-left: 20px; border: none;"> <tr> <td>(A) Test Cable(s)</td> <td>=</td> <td>–1.4 dB</td> </tr> <tr> <td>(B) 20 dB Attenuator</td> <td>=</td> <td>–20.1 dB</td> </tr> <tr> <td>(B) Directional Coupler</td> <td>=</td> <td>–29.8 dB</td> </tr> </table> </li> </ul>	(A) Test Cable(s)	=	–1.4 dB	(B) 20 dB Attenuator	=	–20.1 dB	(B) Directional Coupler	=	–29.8 dB
(A) Test Cable(s)	=	–1.4 dB								
(B) 20 dB Attenuator	=	–20.1 dB								
(B) Directional Coupler	=	–29.8 dB								

... continued on next page



## Manual Test Cable Setup – continued

**Table F-9:** Calibrating Test Cable Setup (using the HP PCS Interface)

Step	Action
19	After all components are calibrated, reassemble all components together and calculate the total test setup loss by adding up all the individual losses: <ul style="list-style-type: none"> <li>• Example:      Total test setup loss = <math>-1.4 -29.8 -20.1 = -51.3</math> dB.</li> </ul> This calculated value will be used in the next series of tests.
20	Under <b>Screen Controls</b> press the <b>TESTS</b> button to display the <b>TESTS (Main Menu)</b> screen.
21	Select <b>Continue (K2)</b> .
22	Select <b>RF Generator Level</b> and set to $-119$ dBm.
23	Click on <b>Pause for Manual Measurement</b> .
24	Verify the HP8921A Communication Analyzer/83203A CDMA interface setup is as follows (fields not indicated remain at default): <ul style="list-style-type: none"> <li>• Verify the GPIB (HP-IB) address:               <ul style="list-style-type: none"> <li>– under <b>To Screen</b>, select <b>More</b></li> <li>– select <b>IO CONFIG</b></li> <li>– Set HP-IB Adrs to <b>18</b></li> <li>– set Mode to <b>Talk&amp;Lstn</b></li> </ul> </li> <li>• Verify the HP8921A is displaying frequency (instead of RF channel)               <ul style="list-style-type: none"> <li>– Press the blue <b>[SHIFT]</b> button, then press the Screen Control <b>[DUPLEX]</b> button; this switches to the <b>CONFIG (CONFIGURE)</b> screen.</li> <li>– Use the cursor control to set RF Display to <b>Freq</b></li> </ul> </li> </ul>
25	Refer to Chapter 3 for assistance in setting the cable loss values into the LMF.

F

# Manual Test Cable Setup – continued

**Figure F-5: Cable Calibration Using HP8921 with PCS Interface**

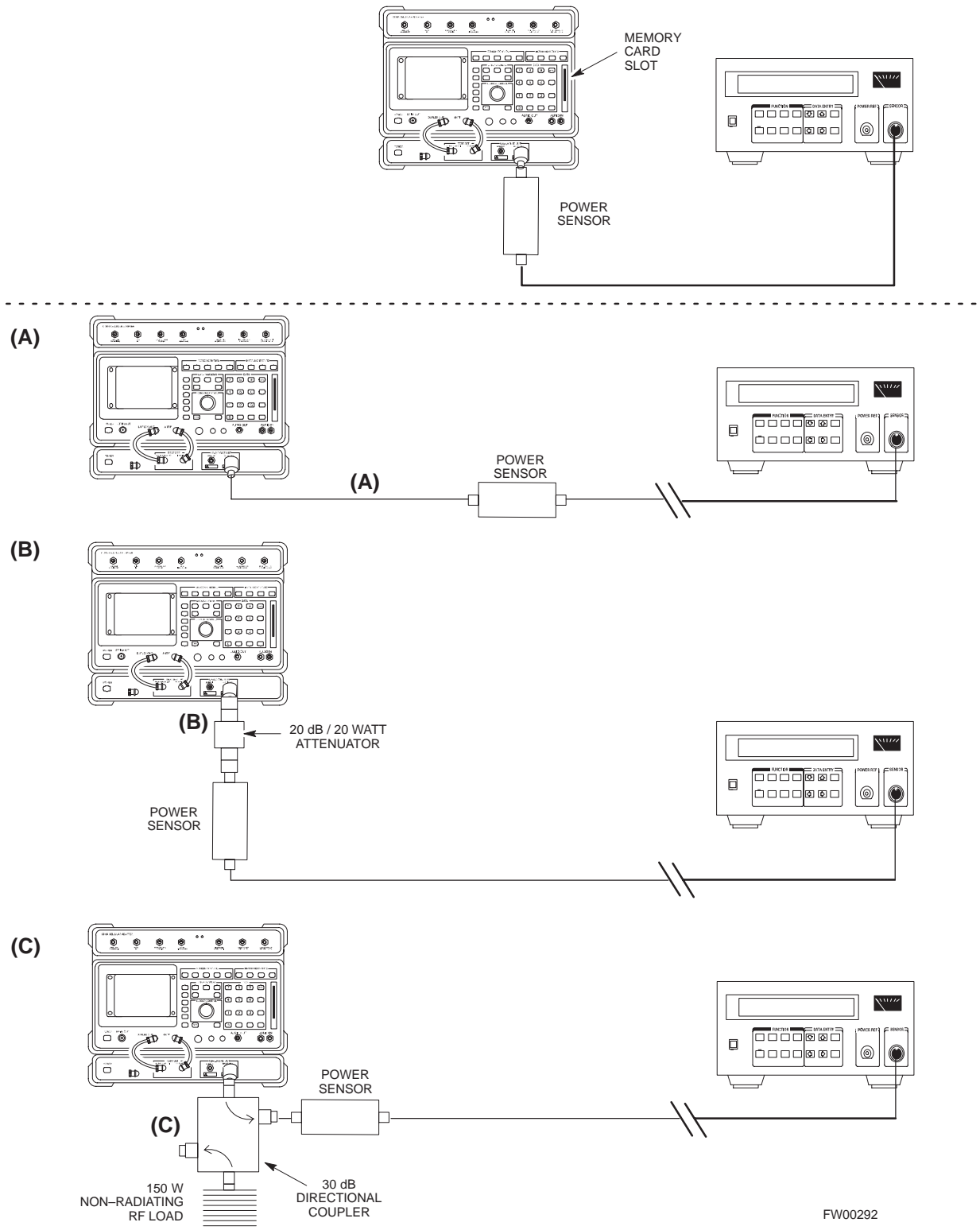

**F**

FW00292

## Manual Test Cable Setup – continued

### Calibrating Test Cable Setup using Advantest R3465

#### NOTE

Be sure the GPIB Interface is OFF for this procedure.

Advantest R3465 Manual Test setup and calibration must be performed at both the TX and RX frequencies.

**Table F-10:** Procedure for Calibrating Test Cable Setup Using Advantest R3465

Step	Action
	<p><b>* IMPORTANT</b></p> <p>– This procedure can only be performed <i>after</i> test equipment has been allowed to warm-up and stabilize for a <i>minimum of 60 minutes</i>.</p>
1	Press the <b>SHIFT</b> and the <b>PRESET</b> keys located below the display
2	Press the <b>ADVANCE</b> key in the MEASUREMENT area of the control panel.
3	Select the <b>CDMA Sig</b> CRT menu key
4	Select the <b>Setup</b> CRT menu key
5	Using the vernier knob and the cursor keys set the following parameters
	<p><b>NOTE</b></p> <p>Fields not listed remain at default</p> <p><b>Generator Mode:</b> SIGNAL</p> <p><b>Link:</b> FORWARD</p> <p><b>Level Unit:</b> dBm</p> <p><b>CalCorrection:</b> ON</p> <p><b>Level Offset:</b> OFF</p>
6	Select the <b>return</b> CRT menu key
7	Press <b>FREQ</b> key in the ENTRY area
8	Set the frequency to the desired value using the keypad entry keys
9	Verify that the <b>Mod</b> CRT menu key is highlighting OFF; if not, press the <b>Mod</b> key to toggle it OFF.
10	Verify that the <b>Output</b> CRT menu key is highlighting OFF; if not, press the <b>Output</b> key to toggle it OFF.
11	Press the <b>LEVEL</b> key in the ENTRY area.
12	Set the LEVEL to <b>0 dBm</b> using the key pad entry keys.
13	Zero power meter. Next connect the power sensor directly to the “RF OUT” port on the R3561L CDMA Test Source Unit.
14	Press the <b>Output</b> CRT menu key to toggle Output to ON.
15	Record the power meter reading _____

... continued on next page



## Manual Test Cable Setup – continued

**Table F-10: Procedure for Calibrating Test Cable Setup Using Advantest R3465**

Step	Action								
16	<p>Disconnect the power meter sensor from the R3561L RF OUT jack.</p> <p><b>* IMPORTANT</b>                      The Power Meter sensor's lower limit is -30 dBm. Thus, only components having losses <math>\leq 30</math> dB should be measured using this method. <b>For best accuracy, always re-zero the power meter before connecting the power sensor to the component being calibrated. Then, after connecting the power sensor to the component, record the calibrated loss immediately.</b></p>								
17	<p>Disconnect all components in the the test setup and calibrate each one separately. Connect each component one-at-a-time between the "RF OUT" port and the power sensor (see Figure F-6, "Setups A, B, and C"). Record the calibrated loss value displayed on the power meter for each connection.</p> <p>Example:</p> <table border="0" data-bbox="406 693 958 829"> <tr> <td>(A) 1st Test Cable</td> <td>= -0.5 dB</td> </tr> <tr> <td>(B) 2nd Test Cable</td> <td>= -1.4 dB</td> </tr> <tr> <td>(C) 20 dB Attenuator</td> <td>= -20.1 dB</td> </tr> <tr> <td>(D) 30 dB Directional Coupler</td> <td>= -29.8 dB</td> </tr> </table>	(A) 1st Test Cable	= -0.5 dB	(B) 2nd Test Cable	= -1.4 dB	(C) 20 dB Attenuator	= -20.1 dB	(D) 30 dB Directional Coupler	= -29.8 dB
(A) 1st Test Cable	= -0.5 dB								
(B) 2nd Test Cable	= -1.4 dB								
(C) 20 dB Attenuator	= -20.1 dB								
(D) 30 dB Directional Coupler	= -29.8 dB								
18	Press the <b>Output</b> CRT menu key to toggle Output OFF.								
19	<p>Calculate the total test setup loss by adding up all the individual losses:</p> <p>Example: Total test setup loss = <math>0.5 + 1.4 + 20.1 + 29.8 = 51.8</math> dB</p> <p>This calculated value will be used in the next series of tests.</p>								
20	Press the <b>FREQ</b> key in the ENTRY area								
21	Using the keypad entry keys, set the test frequency to the RX frequency								
22	Repeat steps 9 through 19 for the RX frequency.								
23	Refer to Chapter 3 for assistance in setting the cable loss values into the LMF.								



# Manual Test Cable Setup – continued

Figure F-6: Cable Calibration using Advantest R3465

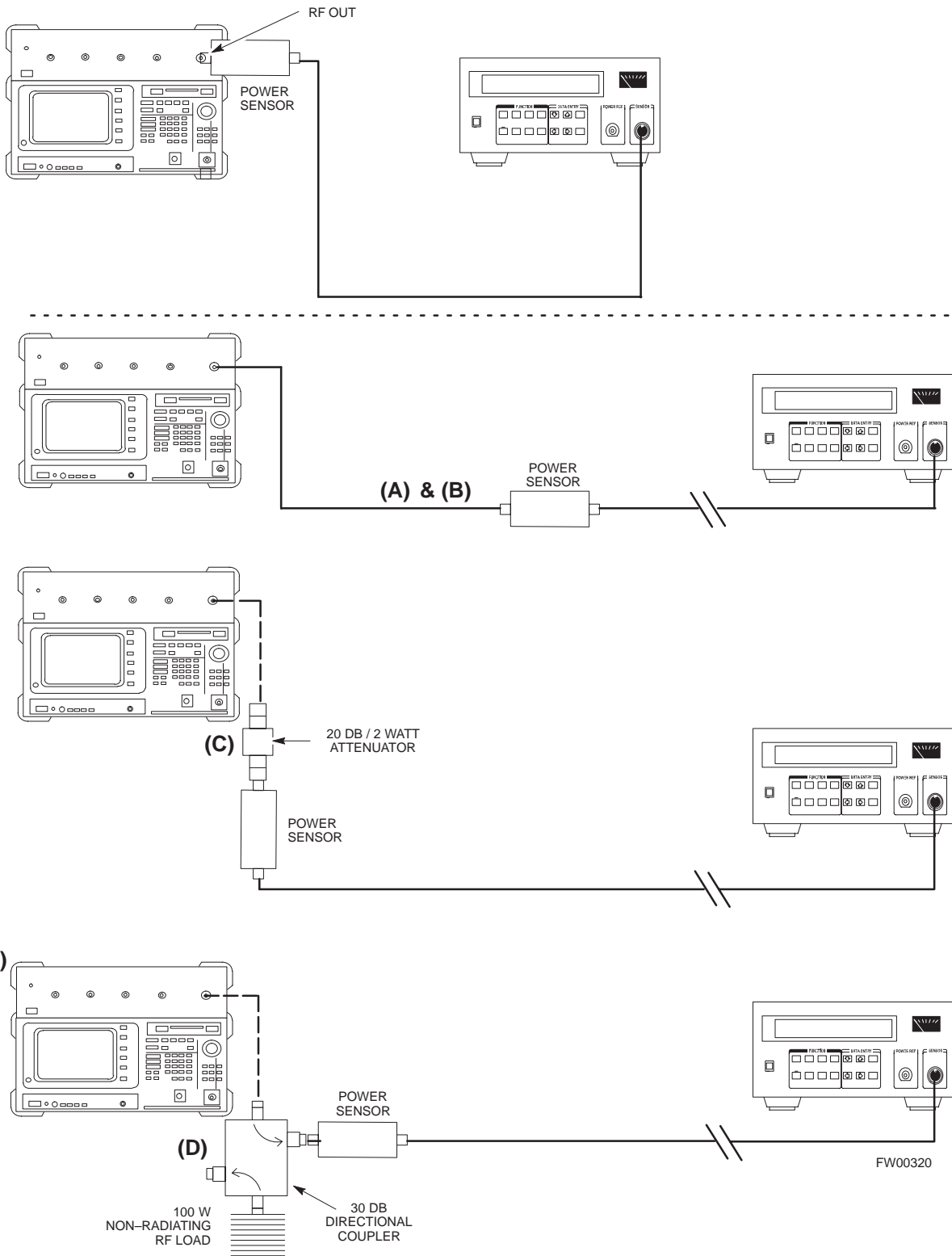

F

# Manual Test Cable Setup – continued

## Calibrating HP 437 Power Meter

Precise transmit output power calibration measurements are made using a bolometer-type broadband power meter with a sensitive power sensor. Follow the steps outlined in Table F-11 to enter information unique to the power sensor before calibrating the test setup. Refer to Figure F-7 as required.



### IMPORTANT

This procedure must be done *in conjunction with* the automated calibration to enter power sensor specific calibration values.

**Figure F-7:** Power Meter Detail

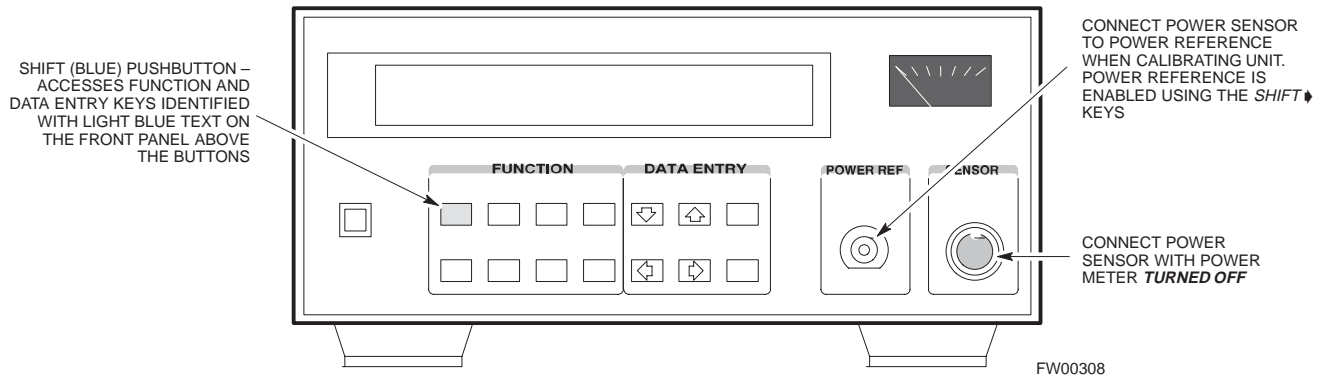
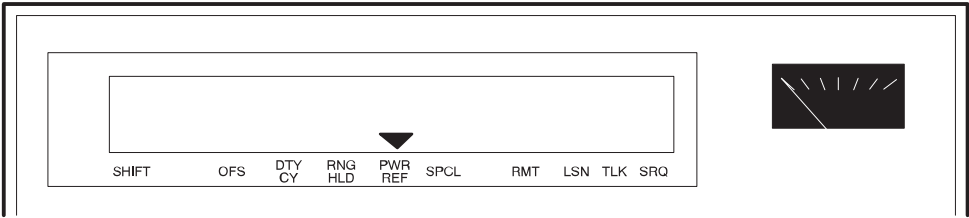

**Table F-11:** Power Meter Calibration Procedure

Step	Action
	<p><b>! CAUTION</b></p> <p>Do not connect/disconnect the power meter sensor cable with ac power applied to the meter. Disconnection could result in destruction of the sensing element or mis-calibration.</p>
1	<ul style="list-style-type: none"> <li>- Make sure the power meter <b>AC LINE</b> pushbutton is <b>OFF</b>.</li> <li>- Connect the power sensor cable to the <b>SENSOR</b> input.</li> </ul>
2	<p>Set the <b>AC LINE</b> pushbutton to <b>ON</b>.</p> <p><b>NOTE</b></p> <p>The calibration should be performed only after the power meter and sensor have been allowed to warm-up and stabilize for a <i>minimum of 60 minutes</i>.</p>
3	<p>Perform the following to set or verify the GPIB address:</p> <ul style="list-style-type: none"> <li>- To enter the <b>SPECIAL</b> data entry function, press <b>[SHIFT]</b> then <b>[PRESET]</b>.</li> <li>- Use the <b>[▲]</b> or <b>[▼]</b> button to select <b>HP-IB ADRS</b>; then press <b>[ENTER]</b>.</li> <li>- Use the <b>[▲]</b> or <b>[▼]</b> button to select <b>HP-IB ADRS 13</b>; then press <b>[ENTER]</b>.</li> <li>- To <b>EXIT</b> the <b>SPECIAL</b> data entry function press <b>[SHIFT]</b> then <b>[ENTER]</b>.</li> </ul>

... continued on next page

**Table F-11: Power Meter Calibration Procedure**

Step	Action
4	<p>Perform the following to set or verify the correct power sensor model:</p> <ul style="list-style-type: none"> <li>– Press <b>[SHIFT]</b> then <b>[↩]</b> to select <b>SENSOR</b>.</li> <li>– Identify the power sensor model number from the sensor label. Use the <b>[↗]</b> or <b>[↘]</b> button to select the appropriate model; then press <b>[ENTER]</b>.</li> </ul> <p><b>NOTE</b> Be sure the <b>PWR REF</b> (power reference) output is OFF (observe that the triangular indicator is NOT displayed as shown in Step 7). If on, press <b>[SHIFT]</b> then <b>[↩]</b> to turn it off.</p>
5	Press <b>[ZERO]</b> . Display will show “Zeroing *****.” Wait for process to complete.
6	Connect the power sensor to the <b>POWER REF</b> output.
7	<p>To turn on the <b>PWR REF</b>, perform the following:</p> <ul style="list-style-type: none"> <li>– Press <b>[SHIFT]</b> then <b>[↩]</b>.</li> <li>– Verify that the triangular indicator (below) appears in the display above “PWR REF”.</li> </ul> <div style="text-align: center;">  <p>The diagram shows a rectangular display area with a horizontal line of indicators below it. The indicators are labeled from left to right: SHIFT, OFS, DTY CY, RING HLD, PWR REF, SPCL, RMT, LSN, TLK, SRQ. A small downward-pointing triangle is positioned above the PWR REF label. To the right of the display area is a separate graphic of a triangular indicator, which is a dark rectangle with a white diagonal line from the top-left to the bottom-right.</p> </div>
8	<p>Perform the following to set the <b>REF CF %</b>:</p> <ul style="list-style-type: none"> <li>– Press (<b>[SHIFT]</b> then <b>[ZERO]</b>) for <b>CAL</b>.</li> <li>– Enter the sensor’s <b>REF CF %</b> from the sensor’s decal using the arrow keys and press <b>[ENTER]</b>. (The power meter will display “CAL *****” for a few seconds.)</li> </ul> <p><b>NOTE</b> If the REF CAL FACTOR (REF CF) is not shown on the power sensor, assume it to be 100%.</p>
9	<p>Perform the following to set the <b>CAL FAC %</b>:</p> <ul style="list-style-type: none"> <li>– Press <b>[SHIFT]</b> then <b>[FREQ]</b> for <b>CAL FAC</b>.</li> <li>– On the sensor’s decal, locate an approximate calibration percentage factor (<b>CF%</b>) at 2 GHz. Enter the sensor’s calibration % (<b>CF%</b>) using the arrow keys and press <b>[ENTER]</b>.</li> </ul> <p>When complete, the power meter will typically display 0.05 dBm. (Any reading between 0.00 and 0.10 is normal.)</p>
10	<p>To turn off the <b>PWR REF</b>, perform the following:</p> <ul style="list-style-type: none"> <li>– Press <b>[SHIFT]</b> then <b>[↩]</b>.</li> <li>– Disconnect the power sensor from the <b>POWER REF</b> output.</li> </ul>

F

## Manual Test Cable Setup – continued

### Calibrating Gigatronics 8542 power meter

Precise transmit output power calibration measurements are made using a bolometer-type broadband power meter with a sensitive power sensor. Follow the steps in Table F-12 to enter information unique to the power sensor.

**Table F-12: Calibrate Gigatronics 8542 Power Meter**

Step	Action
	<b>! CAUTION</b> Do not connect/disconnect the power meter sensor cable with AC power applied to the meter. Disconnection could result in destruction of the sensing element or miscalibration.
	<b>NOTE</b> Allow the power meter and sensor to warm up and stabilize for a <i>minimum of 60 minutes</i> before performing the calibration procedure.
1	<ul style="list-style-type: none"><li>• Make sure the power meter <b>POWER</b> pushbutton is <b>OFF</b>.</li><li>• Connect the power sensor cable to the <b>SENSOR</b> input.</li><li>• Set the <b>POWER</b> pushbutton to <b>ON</b>.</li></ul>
2	Verify the Power GPIB mode and address: <ul style="list-style-type: none"><li>• Press <b>MENU</b>. Use the <b>▼</b> arrow key to select <b>CONFIG MENU</b>, and press <b>ENTER</b>.</li><li>• Use the <b>▼</b> arrow key to select <b>GPIB</b>, and press <b>ENTER</b>.</li><li>• Use the <b>▼▲</b> arrow keys as required to set <b>MODE</b> to <b>8541C</b> or <b>8542C</b> (<i>as appropriate</i>).</li><li>• Press <b>▶</b> and use the <b>▼▲</b> arrow keys as required to set <b>ADDRESS</b> to <b>13</b>.</li><li>• Press <b>ENTER</b>.</li></ul>
3	<ul style="list-style-type: none"><li>• Connect the power sensor to the <b>CALIBRATOR</b> output connector.</li><li>• Press <b>ZERO</b>.</li><li>• Wait for the process to complete. Sensor factory calibration data is read to power meter during this process.</li><li>• Disconnect the power sensor from the <b>CALIBRATOR</b> output.</li></ul>



Figure F-8: Gigatronics 8542C Power Meter Detail

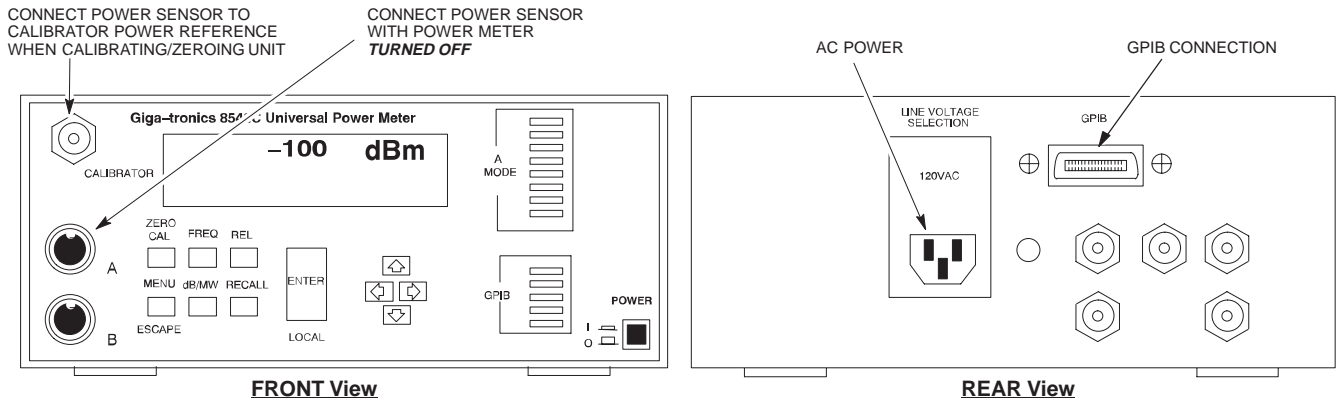

FW00564

F

## Appendix G: Download ROM Code

### Appendix Content

---

Downloading ROM Code with the LMF .....	F-1
Exception Procedure – Downloading Device ROM Code .....	F-1







---

## Downloading ROM Code with the LMF

### Exception Procedure – Downloading Device ROM Code

This procedure is not part of a normal optimization.

Perform this procedure only on an exception basis when no alternative exists to load a BTS device with the correct version of ROM code.

#### NOTE

An MGLI or GLI must be INS (green) before ROM code can be downloaded to non-GLI devices.



#### WARNING

Release 2.9.x RAM code must NOT be downloaded to a device loaded with Release 2.8.x ROM code, and Release 2.8.x RAM code must NOT be downloaded to a device loaded with Release 2.9.x ROM code.

All devices in a BTS must have the same Release-level ROM and RAM code before the optimization and ATP procedures can be performed.

If a newly-installed Release 8-equipped BTS is to be upgraded to Release 2.9.x, the optimization and Acceptance Test Procedures (ATP) should be accomplished with the Release 2.8.x code and software. Following the optimization, the site code and software should be upgraded to Release 2.9.x by the CBSC. It is not necessary to perform the optimization and ATPs again after the upgrade.

If a replacement device with Release 2.8.x ROM code must be used in a Release 2.9.x-equipped BTS, the device ROM code can be changed using the CDMA LMF before the performing the BTS optimization and ATPs. *A device loaded with Release 2.9.x ROM code can not be converted back to Release 2.8.x ROM code in the field without Motorola assistance.*

If it is necessary to download ROM code to a device from the CDMA LMF, the procedure in Table G-1 includes steps *for both ROM and RAM code download* using the CDMA LMF.

#### Prerequisites

Prior to performing this procedure, ensure the correct ROM and RAM code files exist on the CDMA LMF for each of the devices to be loaded.



**CAUTION**

The Release level of the ROM code to be downloaded must be the same as the Release level of the ROM code resident in the other devices in the BTS. Release 2.9.x ROM code must not be downloaded to a frame having Release 2.8.x code, and Release 2.8.x code must not be downloaded to a frame having Release 2.9.x code.

*This procedure should only be used to upgrade replacement devices for a BTS. It should NOT be used to upgrade all devices in a BTS. If a BTS is to be upgraded from Release 2.8.x to Release 2.9.x, optimization and ATP must first be performed with the BTS in a Release 2.8.x configuration. Following this, the upgrade from Release 2.8.x to Release 2.9.x should be done by the CBSC.*

**Table G-1:** Download ROM and RAM Code to Devices

Step	Action
1	Click on the device to be loaded.
2	From the <b>Device</b> pull down menu, select <b>Status</b> . A status report window will appear
3	Make a note of the number in the <b>HW Bin Type</b> column. <b>NOTE</b> “HW Bin Type” is the Hardware Binary Type for the device. This number is used as the last four digits in the filename of a device’s binary ROM code file. Using this part of the filename, the ROM code file can be matched to the device in which it is to be loaded.
4	Click <b>OK</b> to close the status window.
5	Click on the device to be loaded.
6	<b>* IMPORTANT</b> The CDMA LMF will not automatically select ROM code files for download. ROM code files must be selected <i>manually</i> . From the <b>Device</b> pull down menu, select <b>Download Code Manual</b> . A file selection window will appear.
7	Double-click on the version folder with the desired version number for the ROM code file.
8	Double-click the <b>Code</b> folder. A list of ROM and RAM code files will be displayed.

... continued on next page

F

## Downloading ROM Code with the LMF – continued

**Table G-1: Download ROM and RAM Code to Devices**

Step	Action
9	<p><b>! CAUTION</b> A ROM code file with the correct hardware binary type (HW Bin Type) must be chosen. Using a file with the wrong HW Bin Type can result in unpredictable operation and damage to the device.</p> <p>Click on the ROM code file with the filename which matches the device type and HW Bin Type number noted in step 3 (e.g., file <b>bbx_rom.bin.0604</b> is the ROM code file for a BBX with a HW Bin Type of 0604). The file should be highlighted.</p>
10	<p>Click on the <b>Load</b> button. A status report window is displayed showing the result of the download.</p>
11	<p>Click <b>OK</b> to close the status window.</p>
12	<p>From the <b>Util</b> pull down menu, select <b>Tools</b>, then <b>Update NextLoad</b>.</p>
13	<p>Select the version number of the folder that was used for the ROM code download and click <b>Save</b>. A pop-up message will appear showing the CDF file has been updated.</p>
14	<p>Click on the <b>OK</b> button to dismiss the pop-up message.</p>
15	<p>Click on the device that was loaded with ROM code.</p>
16	<p><b>NOTE</b> RAM code is automatically selected for download.</p> <p>From the <b>Device</b> pull down menu, select <b>Download Code</b> to download RAM code. A status report is displayed showing the result of the download.</p>
17	<p>Click <b>OK</b> to close the status window.</p>
18	<p>Observe the downloaded device to ensure it is OOS-RAM (yellow) for non-GLI devices or INS (green) for GLIs.</p>
19	<p>Click on the device which was loaded with code.</p>
20	<p>From the <b>Device</b> pull down menu, select <b>Status</b>. Verify that the correct ROM and RAM version numbers are displayed in the status report window.</p>
21	<p>Click <b>OK</b> to close the status window.</p>
	<p><b>NOTE</b> Data is automatically downloaded to GLI devices when the RAM code is downloaded. Use the data download portion of the <i>Download RAM Code and Data to Non-GLI Devices</i> procedure, Table 3-14, to download data to other device types after their ROM code has been upgraded and RAM code downloaded.</p>





## Numbers

10 MHz Rubidium Standard, optional test equipment, 1-11

10BaseT/10Base2 converter  
LMF to BTS connection, 3-20  
remove from BTS, 5-4

2-way splitter, optional test equipment, 1-10

## A

Abbreviated

RX acceptance test, all-inclusive, 4-4  
TX acceptance test, all-inclusive, 4-4

Acceptance Test Procedure. *See* ATP

ACTIVE LED

GLI, 6-25  
MCC, 6-27

Alarm and Span Line Cable Pin/Signal Information, 3-6

ALARM LED, GLI, 6-25

Alarm Monitor window, 3-85

Alarm Reporting Display, 3-85

All RX ATP Test Procedure, 4-6

All tests fail on a single antenna, Troubleshooting, RFDS, 6-21

All TX ATP Test Procedure, 4-5

All TX/RX ATP Test Procedure, 4-5

AMR, 1-18

Ancillary frame, when to optimize, B-1

Applying AC Power, 2-9

ATP

all inclusive TX acceptance test outline, 4-4  
automated introduction, 4-1

code domain noise floor acceptance test procedure, 4-16

code domain power acceptance test procedure, 4-16

failure report generation, 4-20

FER test, frame error rate testing, 4-19

pilot time offset, 4-13

prerequisites, 4-2

spectral purity TX mask, 4-10

test matrix/detailed optimization, B-2

waveform quality (Rho), 4-12

waveform quality (RHO) acceptance test procedure, 4-12

Attenuator, required test equipment, 1-9

## B

Basic Troubleshooting Overview, 6-1

Battery Charge Test (Connected Batteries), 2-11

Battery Discharge Test, 2-12

Bay Level offset calibration failure, 6-7

BBX

carrier spectral purity, 4-9

gain set point vs SIF output considerations, C-1  
primary and redundant, TX tests to be performed, 4-7

BBX2, 1-18

BBX2 Connector, 6-15

BBX2 LED Status Combinations, 6-27

BDC, pilot gain setting, 4-18

Bringing modules into service, prepare to leave the site, 5-3

Broad Band Receiver. *See* BBX

BTS

download, 3-30

Ethernet LAN interconnect diagram, 3-28

LMF connection, 3-9, 3-20

log out of session, 5-4

- RX sensitivity/frame error rate, 4-8
  - system software download, 3-3
  - when to optimize, B-1
- BTS Frame Erasure Rate. *See* FER
- BTS Log In Procedure, GUI, 3-22
- BTS login
  - CLI environment, 3-24
  - General, 3-21
  - GUI environment, 3-22
- BTS Logout
  - CLI environment, 3-26
  - GUI environment, 3-25
- BTS Site Setup for Acceptance Test Procedures, 3-74
- Create CAL File, 3-75
- bts–nnn.cal File, 3-16
- C**
- Cables Connection for 10 MHz Signal and GPIB ,  
F-2, F-4
- Calibrate BLO, 3-64
- Calibrating Cables, 3-58
- Calibrating Test Cable Setup, PCS Interface  
HP83236B, F-10
- Calibrating Test Equipment, 3-58
- Calibration
  - data file calibration, BLO, 3-66
  - power meter, Gigatronics 8542B, F-19
- Calibration Audit failure, 6-8
- calibration data file, description of, BLO, 3-66
- Cannot communicate to Communications Analyzer,  
6-3
- Cannot communicate to Power Meter, 6-2
- Cannot Download DATA to any device card, 6-4
- Cannot ENABLE device, 6-5
- Cannot Log into cell–site, 6-2
- Cannot perform carrier measurement, 6-10
- Cannot perform Code Domain Noise Power  
measurement, 6-10
- Cannot perform Rho or pilot time offset  
measurement, 6-9
- Cannot perform Txmask measurement, 6-9
- cbsc folder, 3-17
- CCD, 1-18
- CDF
  - site configuration, 3-2
  - site equipage verification, 3-3
  - site type and equipage data information, 2-1
- CDMA
  - allocation diagram for the North American, cellular  
telephone frequency spectrum, D-4
  - optimization/ATP test matrix, B-1
  - subscriber mobile radiotelephone, optional test  
equipment, 1-10
- cdma Folder, 3-15
- Cell Site
  - equipage verification, 2-1
  - types configuration, 3-2
- Cell Site Data File. *See* CDF
- Channel Service Unit, 3-4
- CIO, 1-18
- CIO Connectors, 6-15
- Clock Sync Module. *See* CSM
- Code domain power/noise floor
  - acceptance test, 4-15
  - analyzer display, 4-17
- code Folder, 3-17
- Communication test set, rear panel, F-2, F-4
- Communications test set. *See* Test equipment
- Connect BTS T1 spans, 5-5
- Connecting test equipment to the BTS, 3-47
- Connector Functionality
  - Backplane, Troubleshooting, 6-14
  - Troubleshooting, Backplane, 6-14
- Control, TX output verification, 4-3
- Copy CBSC CDF Files to the LMF, 3-11
- Copying CAL files from CDMA LMF to the CBSC,  
5-1
- Copying CAL files to the CBSC, 5-1
- CSM, 1-18
  - and LFR primary functions, 3-37
- CSM frequency verification, 3-39
- CSM LED Status Combinations, 6-23
- Customer I/O, 1-20

## **D**

data Folder, 3-18

DC Power Pre-test (BTS Frame), 2-7

DC Power Problems, C-CCP Backplane  
  Troubleshooting, 6-18

DC/DC Converter LED Status Combinations, 6-22

Detailed, optimization/ATP test matrix, B-2

Devices, download. *See* Download

Digital Control Problems, 6-16  
  C-CCP Backplane Troubleshooting, 6-16

Digital multimeter, required test equipment, 1-9

Directional coupler, required test equipment, 1-9

Documents, required, 1-12

Download  
  *See also* Devices  
  BTS, 3-30  
  BTS system software, 3-3

Download BLO Procedure, 3-70

Download from the CBSC, prepare to leave the site,  
  5-3

download ROM and RAM code, G-2

Download/Enable MCCs, 3-35

Download/Enable MGLIs, 3-32

Duplexer, optional test equipment, 1-10

Duplexer/Directional Coupler DDC, 1-18, 1-20, 1-21

## **E**

E1, isolate BTS from the E1 spans, 3-4

Enable CSMs & BDCs, 3-34

End LMF session, 5-4

Equipment Overview, 1-14

Equipment warm-up, 3-49

establish MMI communication, 3-26

Ethernet LAN  
  interconnect diagram, 3-28  
  transceiver, 1-7

Every test fails, Troubleshooting, RFDS, 6-20

## **F**

Failure report generation, 4-20

FER, acceptance test, 4-19

Files  
  calibration data file, BLO, 3-66  
  intermediate file, 4-20

Filtronic, low IM Duplexer (Cm035-f2) or  
  equivalent, optional test equipment, 1-10

Fluke, model 8062A with Y8134 test lead kit, test  
  equipment, 1-9

Folder Structure Overview, 3-15

Frame, equipage preliminary operations, 2-1

FREQ Monitor Connector, CSM, 6-24

Frequency counter, optional test equipment, 1-10

## **G**

Gain set point, C-1

Generating an ATP Report, 4-20

General optimization checklist, test data sheets, A-4

Gigatronics 8542B power meter, illustration, F-20

GLI Connector, 6-14

GLI Ethernet A and B Connections, 6-15

GLI LED Status Combinations, 6-25

GLI Pushbuttons and Connectors, 6-26

GLI2, 1-18

GLI2 Front Panel Operating Indicators, 6-26

GPIB, F-1, F-5, F-7  
  cables, 1-8

GPS, receiver operation, test data sheets, A-5

GPS Initialization/Verification  
  estimated position accuracy, 3-40  
  surveyed position accuracy, 3-40

GPS satellite system, 3-35

Group Line Interface. *See* GLI

## **H**

Hardware Requirements, 1-6

High Stability 10 MHz Rubidium Standard, optional  
  test equipment, 1-11

High-impedance conductive wrist strap, required test  
  equipment, 1-9

HP 83236A, F-5  
HP 8921A/600 test set, 1-8  
HP8921A, F-5  
HSO, 1-18  
HSO Initialization/Verification, 3-37  
Huber & Suhner, required test equipment, 1-9  
HyperTerminal, Creating named HyperTerminal connection, 3-13  
HyperTerminal , create named connection, 3-13

**I**

I and Q values, E-1  
Initial HP8921A setup, F-10  
Initial Installation of Boards/Modules, preliminary operations, 2-1  
Initial power tests, test data sheets, A-3  
Inter-frame cabling, when to optimize, B-2  
Intermediate file, generate ATP file using, 4-20  
Internal FRUs, 1-17  
IS-97 specification, E-1  
ISB Inter Shelf Bus connectors, 6-14

**L**

LAN  
    BTS frame interconnect, illustration, 3-28  
    optional test equipment, 1-10  
LED Status Combinations for all Modules except  
    GLI2 CSM BBX2 MCC24 MCC8E, 6-22  
LFR, receiver operation, test data sheets, A-6  
LMF, F-1, F-7  
    BTS connection, 3-20  
    logout procedure, 5-4  
    platform requirements, 1-6  
    remove from BTS, 5-4  
    shut down UNIX, 5-4  
    terminal, 1-6  
    to BTS connection, 3-4, 3-9  
    TX acceptance tests, 4-3  
    view CDF information, 3-3  
lmf Folder, 3-15  
Load Center Wiring, 2-5

loads folder, 3-17  
Local Maintenance Facility. *See* LMF  
Log out  
    of BTS, 5-4  
    of LMF PC, 5-4  
Logging Into a BTS, 3-21  
Logging Out, 3-24  
LORAN-C Initialization/Verification, 3-45  
LPA errors, 6-6  
LPA Module LED, 6-28  
LPA Shelf LED Status Combinations, 6-28

**M**

Master Group Line Interface. *See* MGLI  
MASTER LED, GLI, 6-25  
MCC LED Status Combinations, 6-27  
MMI common connections, 3-27  
MMI Connector  
    CSM, 6-24  
    GLI, 6-26  
MMI Connectors, MCC, 6-27  
MMI equipment setup, 3-27  
Module status indicators, 6-22  
MPC, 1-18  
Multi Channel Card. *See* MCC  
Multi-FER test Failure, 6-11

**N**

New installations, 1-4  
No AMR control, 6-17  
No BBX2 control in the shelf, 6-17  
No DC input voltage to Power Supply Module, 6-18  
No DC voltage +5 +65 or +15 Volts to a specific  
    GLI2 BBX2 or Switch board, 6-19  
No GLI2 Control through span line connection, 6-16  
No GLI2 Control via LMF, 6-16  
No or missing MCC24 channel elements, 6-17  
No or missing span line traffic, 6-17  
North American, cellular telephone system frequency spectrum, CDMA allocation, D-4



## O

- Online Help, 3-27
- Optional test equipment, 1-10
  - 10 MHz rubidium standard, 1-11
  - 2-way splitter, 1-10
  - CDMA subscriber mobile or portable radiotelephone, 1-10
  - duplexer, 1-10
  - frequency counter, 1-10
  - LAN tester, 1-10
  - oscilloscope, 1-10
  - RF circular, 1-11
  - RF test cable, 1-10
  - spectrum analyzer, 1-10
- Oscilloscope, optional test equipment, 1-10

## P

- PCMCIA, Ethernet adapter
  - LMF to BTS connection, 3-20
  - remove from BTS, 5-4
- Periodic optimization, 1-4
- Pilot Time Offset. *See* PN
- Pilot time offset, acceptance test, 4-13
- Ping, 3-28
- PN
  - offset programming information, E-1
  - offset usage, E-1
- PN offset per sector, E-1
- PN Offset Usage , E-1
- Power Input, 6-14
- Power Meter
  - illustration, F-17
  - Pre-calibration, F-17
- Power meter
  - calibration, Gigatronics 8542B, F-19
  - illustration, Gigatronics 8542B, F-20
  - required test equipment, 1-8
  - TX acceptance tests, 4-3
- Power Supply Module Interface, 6-14
- Pre-calibration, Power Meter, F-17
- Pre-power tests, test data sheets, A-3
- Preliminary operations
  - cell Site types, 2-1

- test data sheets, A-2
- Prepare to leave site
  - connect BTS T1 spans, 5-5
  - remove external test equipment, 5-3
- Prepare to leave the site
  - bringing modules into service, 5-3
  - download code and data from CBSC, 5-3
- Prerequisites, automated acceptance tests, 4-2
- Procedures to Copy CAL Files From Diskette to the CBSC, 5-1, 6-2, 6-3, 6-4
- Procedures to Copy Files to a Diskette, 5-1
- Program, TSU NAM, 3-84
- Pseudorandom Noise. *See* PN
- Punch Block, 3-6
- PWR/ALM and ACTIVE LEDs, MCC, 6-27
- PWR/ALM LED
  - BBX2, 6-27
  - CSM, 6-23
  - DC/DC Converter, 6-22
  - generic, 6-22
  - MCC, 6-27

## R

- RAM code, described, 3-30
- Report generation, ATP report, 4-20
- Required test equipment
  - communications system analyzer, 1-6, 1-8
  - digital multimeter, 1-9
  - directional coupler, 1-9
  - Ethernet LAN transceiver, 1-7
  - GPIB cables, 1-8
  - high-impedance conductive wrist strap, 1-9
  - power meter, 1-8
  - RF adapters, 1-9
  - RF attenuator, 1-9
  - RF load, 1-9
  - RS232 to GPIB interface, 1-7
  - timing reference cables, 1-9
- Required test equipment and software, list, 1-6
- RESET Pushbutton, GLI, 6-26
- RF
  - attenuator, 1-9
  - Circular – optional test equipment, 1-11
  - load for required test equipment, 1-9
  - required test equipment load, 1-9

test cable, 1-9

RF Path Bay Level Offset Calibration, 3-64

RFDS – Fault Isolation, 6-20

RFDS Calibration, 3-82

RFDS Location, SC 4812ET, 1-21

RFDS Test Subscriber Unit, 3-31

RFDS TSU Calibration Channel Frequencies, 3-82

Rho

- TX waveform quality acceptance test, 4-12
- waveform quality requirements, 4-12

ROM code

- described, 3-30
- downloading, G-1

ROM code download Caution, 3-32, G-2

ROM code download Warning, G-1

RS232 to GPIB interface

- modifications required for Automated Testing, 1-7
- required test equipment, 1-7

RX

- acceptance tests, FER, 4-18
- antenna VSWR, test data sheets, A-11
- sensitivity/frame error rate, 4-8

RX and TX paths fail, Troubleshooting, RFDS, 6-20

**S**

SC 4812 BTS Optimization/ATP Test Matrix, B-4

SCCP Backplane Troubleshooting, Procedure, 6-15

SCCP shelf, 1-18

SCLPA, convergence test data sheets, A-7

Selecting Test Equipment, 3-56

Set Antenna Map Data, 3-80

Set RFDS Configuration Data, 3-81

Setting Cable Loss Values, 3-62

Setting Control Port, 3-5

Setting TX Coupler Loss Value, 3-63

SIF, output considerations vs BBX gain set point, C-1

Site, equipage verification, 3-3

Site checklist, verification data sheets, A-2

Site documents, 1-12

site equipage, CDF file, 3-2

Site expansion, 1-4

Span line

- T1/E1 verification equipment, 1-10
- troubleshooting, 6-29

Span line configuration, troubleshooting, 6-30

Span Line connector , 6-14

SPANS LED, 6-25

Spectral purity, TX mask – primary and redundant BBX, 4-7

Spectral purity transmit mask, acceptance test, 4-10

Spectrum analyzer, optional test equipment, 1-10

STATUS LED, GLI, 6-25

Supported Test Sets, 3-47

SYNC Monitor Connector, CSM, 6-24

System Connectivity Test, F-5

## **T**

T1, isolate BTS from the T1 spans, 3-4

Tektronics model 2445 test equipment, 1-10

Telco Interface Board TIB, 1-20

Test data sheets

- Alarm verification, A-11
- general optimization checklist, A-4
- GPS receiver operation, A-5
- initial power tests, A-3
- LFR receiver operation, A-6
- pre-power tests, A-3
- preliminary operations, A-2
- RX antenna VSWR, A-11
- SCLPA convergence, A-7
- site checklist, A-2
- TX antenna VSWR, A-10
- TX BLO, A-8
- verification of test equipment used, A-1

Test equipment

- See also* Optional test equipment; Required test equipment
- set up, TX output verification/control, 4-3
- system analyzer, 1-8
- TX acceptance tests, 4-3
- verification data sheets, A-1

Test equipment connections , F-1

- Test Equipment Setup, 3-47
  - Test Equipment Setup Calibration for TX Bay Level Offset, 3-61, F-14
  - Test Equipment Setup Chart, 3-48
  - Test equipment setup RF path calibration, 3-68
  - Test Set Calibration, 3-55
  - Timing reference cables, required test equipment
    - Model SGLN1145A/4132A CSMs, 1-9
    - Model SGLN4132B CSMs, 1-9
  - Transmit TX path audit, 3-72
  - Transmit TX path calibration, 3-68
  - Transmit/Receive Module TRX, 1-20
  - Troubleshooting
    - DC Power Problems, 6-18
    - Set span configuration, 6-30
    - span problems, 6-29
    - TX and RX Signal Routing, 6-19
  - Troubleshooting CSM Checklist, 6-12
  - TX
    - acceptance tests
      - code domain power/noise floor, 4-15
      - equipment setup, 4-3
      - pilot time offset, 4-13
      - spectral purity mask, 4-9
        - spectrum analyzer display, 4-11
      - waveform quality (rho), 4-12
    - all inclusive TX ATP test, 4-4
    - antenna VSWR, test data sheets, A-10, A-11
    - BLO test data sheets, A-8
    - output acceptance tests
      - code domain power noise, 4-7
      - pilot time offset, 4-7
      - waveform quality, 4-7
  - TX & RX Path Calibration, 3-64
  - TX and RX Frequency vs Channel , D-2
  - TX and RX Signal Routing, C–CCP Backplane Troubleshooting, 6-19
  - TX Audit Test, 3-73
  - TX Bay Level Offset and TX ATP test equipment setup calibration, 3-60
  - tx fine adjust, E-1
  - TX Path Calibration, 3-65
  - TX/RX OUT Connections, 4-2
- U**
- UNIX, shut down on LMF, 5-4
  - Unshielded Twisted Pair. *See* UTP
  - Updating CDMA LMF Files, 5-1
  - UTP, LMF to BTS connection, 3-20
- V**
- Verify
    - test equipment used, test data sheets, A-1
    - TX output, 4-3
  - version Folder, 3-17
  - Virtual BTS, 1-14
- W**
- Waveform quality (Rho), acceptance test procedure, 4-12
  - When to optimize
    - Ancillary – table, B-1
    - BTS, B-1
    - inter–frame cabling, B-2
- X**
- XCVR Backplane Troubleshooting, 6-14
  - Xircom Model PE3–10B2
    - LMF to BTS connection, 3-20
    - remove from BTS, 5-4

