

**EXHIBIT 3**

**Section 2.1033 (c)(3) INSTALLATION AND OPERATING INSTRUCTIONS**

A copy of the installation and operating instructions to be furnished to the user. A draft copy of the instructions may be submitted if the actual document is not available. The actual document shall be furnished to the FCC when it becomes available.

Response

A copy of the “Alcatel-Lucent 9927 Distributed Base Station Outdoor Site Preparation Guidelines” manual is attached to this exhibit.



## Alcatel-Lucent 9927 Distributed Base Station

### Outdoor Site Preparation Guidelines

401-703-516

Issue 1 | March 2012

Alcatel-Lucent - Proprietary  
Use pursuant to applicable agreements

**Legal notice**

Alcatel, Lucent, Alcatel-Lucent and the Alcatel-Lucent logo are trademarks of Alcatel-Lucent. All other trademarks are the property of their respective owners.

The information presented is subject to change without notice. Alcatel-Lucent assumes no responsibility for inaccuracies contained herein.

Copyright © 2012 Alcatel-Lucent. All rights reserved.

Contains proprietary/trade secret information which is the property of Alcatel-Lucent and must not be made available to, or copied or used by anyone outside Alcatel-Lucent without its written authorization.

Not to be used or disclosed except in accordance with applicable agreements.

**Notice**

Every effort was made to ensure that the information in this Information Product (IP) was complete and accurate at the time of printing. However, information is subject to change.

**Ordering information**

The ordering number for this document is 401-703-516. To order this or other Alcatel-Lucent information products, see “To obtain documentation, training, and technical support or submit feedback” on the Flexent<sup>®</sup>/AUTOPLEX<sup>®</sup> *Wireless Networks System Documentation CD-ROM*, 401-010-001 or the documentation web site at ([https://wireless.support.lucent.com/amps/rls\\_info/rls\\_doc/cd\\_docs/customer.support/customer.support\\_toc.pdf.wen](https://wireless.support.lucent.com/amps/rls_info/rls_doc/cd_docs/customer.support/customer.support_toc.pdf.wen)).

**Technical support**

For technical support, see “To obtain documentation, training, and technical support or submit feedback” on the Flexent<sup>®</sup>/AUTOPLEX<sup>®</sup> *Wireless Networks System Documentation CD-ROM*, 401-010-001 or the documentation web site at ([https://wireless.support.lucent.com/amps/rls\\_info/rls\\_doc/cd\\_docs/customer.support/customer.support\\_toc.pdf.wen](https://wireless.support.lucent.com/amps/rls_info/rls_doc/cd_docs/customer.support/customer.support_toc.pdf.wen)).

# About this document

## Purpose

This Information Product (IP) describes the basic site requirements that should be used to plan a Alcatel-Lucent 9927 Distributed Base Station outdoor site. This document includes specific tasks that should be completed at the job site before an installation can begin.

## Reason for reissue

This document is *Alcatel-Lucent 9927 Distributed Base Station Outdoor Site Preparation Guidelines*, document number 401-703-516, Issue 1. This issue incorporates information available as of December 2011.

This is the second issue of this document. Whenever this document is reissued, the reasons for reissue will be provided in this section.

The reasons for reissue are shown in the table below.

Issue	Reason
2	

## Intended audience

This IP is intended for customers preparing a 9927 Distributed Base Station outdoor site.

## Conventions used

The following conventions are used in this IP:

### Measurements

All measurements are shown in metric form, and are followed by the English conversion in parentheses.

**Naming conventions**

In this IP, the *Alcatel-Lucent 9927 Distributed Base Station Outdoor Cabinet* is referred to as *9927 Distributed Base Station Outdoor Cabinet*.

**Standard cross-sections and wire diameters of round copper conductors**

The following table is from CEI/IEC 60947-1:2004, *Table 1, Standard cross-sections of round copper conductors and approximate relationship between mm<sup>2</sup> and AWG/kcmil sizes* for reference. Additional wire sizes are included in this information product as appropriate for the topic.

ISO rated cross-sectional area (mm <sup>2</sup> )	AWG/kcmil size
0.2	24
0.34	22
0.5	20
0.75	18
1	-
1.5	16
2.5	14
4	12
6	10
10	8
16	6
25	4
35	2
-	1
50	0 (1/0)
70	00 (2/0)
95	000 (3/0)
-	0000 (4/0)
120	250 kcmil
150	300 kcmil
185	350 kcmil
-	400 kcmil
240	500 kcmil
300	600 kcmil

ISO rated cross-sectional area (mm <sup>2</sup> )	AWG/kcmil size
NOTE: The dash, when it appears, counts as a size when considering connecting capacity (see 7.1.7.2 in the standard).	

## Related documentation

Base station planners and site preparation personnel must have the appropriate reference material, and all applicable local, regional and national code documentation.

### Alcatel-Lucent documents (required, or required as applicable)

- *Grounding and Lightning Protection Guidelines for Alcatel-Lucent Network Wireless System Cell Sites*, 401-200-115
- *Installation Instructions, Interface Kit for Attachment of 60ECv2 Battery Cabinet to Outdoor 9927 Base Station Primary Cabinet with Integrated Power*, 109621573
- *Installation Instructions, Interface Kit for Non-Standard Attachment of 60ECv2 Battery Cabinet to Outdoor 9927 Base Station Primary Cabinet with Integrated Power*, 109676239
- *Installation Instructions, Interface Kit for Installation of Second 60ECv2 Battery Cabinet with First 60ECv2 Battery Cabinet*, 109683177
- *Engineering Rules for Flexent<sup>®</sup> Modular Cell 4.0B*, ER\_0102\_0004
- *Engineering Rules for Factory and Field Installation Kits for 9927 Distributed Base Station*, ER\_0105\_0006

### Other documents (required)

- *Standard for Installation of Lightning Protection Systems*, NFPA 780
- *Recommended Practices on Surge Voltages in Low Voltage AC Power Circuits*, IEEE C62.41 (Latest Edition)
- *GR-487-CORE*, Telcordia
- *GR-63-CORE*, Telcordia

### Alcatel-Lucent documents (not required)

The following documents are related but not required for a 9927 Distributed Base Station Outdoor Cabinet outdoor site.

- *Alcatel-Lucent 9927 Distributed Base Station System Description*, 401-703-729
- *Alcatel-Lucent CDMA Operations, Administration and Maintenance*, 401-703-407
- *Engineering Rules/Guidelines Flexent<sup>™</sup> 9927 4.0*, ER\_XXXX\_XXXX
- *Power & Battery Engineering Rules for Alcatel-Lucent 9927 Distributed Base Station*, ER\_XXXX\_XXXX\_PWR

---

## Related training

Alcatel-Lucent offers the following product-related training for the 9927 Distributed Base Station Outdoor Cabinet:

- \_\_\_\_\_
- \_\_\_\_\_

## To obtain technical support, documentation, and training or submit feedback

The Online Customer Support (OLCS) web site, <http://support.lucent.com>, provides access to technical support, related documentation, related training and feedback tools. On the right side of the page is a technical support telephone number lookup tool. The site also provides account registration for new users.

## Site preparation checklists

All site preparation activities, as well as adherence to the guidelines, should be verified before the installation of the cell site equipment.

Checklists and punchlists have been provided in [Appendix A, “9927 Distributed Base Station Outdoor Cabinet site preparation checklists”](#). These checklists and punchlists are intended to aid customers and Alcatel-Lucent personnel during a base station site Method of Procedure (MOP) walk-through before equipment installation. Utilization of the checklists helps ensure a quality installation and provides a base station site history file for later reference. The punchlist sheets are used to track completion of any outstanding site preparation items, and to aid in the project management of installation resources.

## Base station configuration sheets

Configuration sheets are provided in [Appendix C, “9927 Distributed Base Station Outdoor Cabinet cell site information”](#) to aid the Customer, Equipment Engineering, and Wireless Project Management during the various stages of product deployment. The configuration sheets are used to document the base station equipment configuration, conditions, and other pertinent information for reference during product deployment, and future additions. The configuration sheets should be completed during the equipment engineering phase. Reference to this information during MOP walk-through assists with completion of the site preparation checklists.

## Safety information

For your safety, this document contains safety statements. Safety statements are given at points where risks of damage to personnel, equipment, and operation may exist. Failure to follow the directions in a safety statement may result in serious consequences.

## **How to comment**

To comment on this document, go to the [Online Comment Form](http://infodoc.alcatel-lucent.com/comments/) (<http://infodoc.alcatel-lucent.com/comments/>) or e-mail your comments to the [Comments Hotline](mailto:comments@alcatel-lucent.com) ([comments@alcatel-lucent.com](mailto:comments@alcatel-lucent.com)).



# 1 Safety

## Overview

### Purpose

This chapter covers safety precautions for the 9927 Distributed Base Station Outdoor Cabinet installation.

### Contents

Structure of safety statements	1-2
Safety - specific hazards	1-5
Product safety	1-8

# Structure of safety statements

## Overview

This topic describes the components of safety statements that appear in this document.

## General structure

Safety statements include the following structural elements:

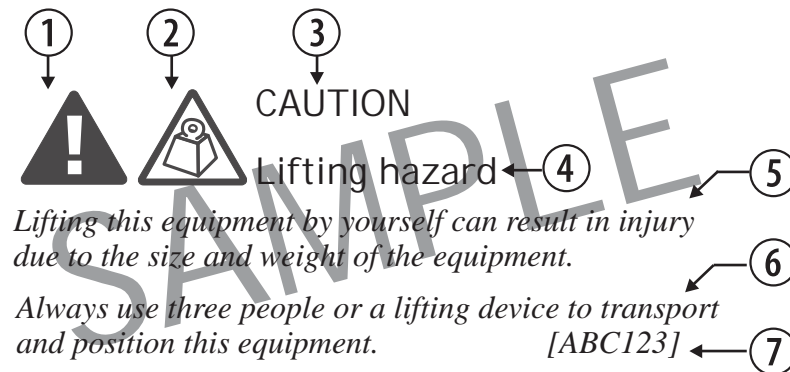

Item	Structure element	Purpose
1	Safety alert symbol	Indicates the potential for personal injury (optional)
2	Safety symbol	Indicates hazard type (optional)
3	Signal word	Indicates the severity of the hazard
4	Hazard type	Describes the source of the risk of damage or injury
5	Safety message	Consequences if protective measures fail
6	Avoidance message	Protective measures to take to avoid the hazard
7	Identifier	The reference ID of the safety statement (optional)

---

**Signal words**

The signal words identify the hazard severity levels as follows:

<b>Signal word</b>	<b>Meaning</b>
DANGER	Indicates an extremely hazardous situation which, if not avoided, will result in death or serious injury.
WARNING	Indicates a hazardous situation which, if not avoided, could result in death or serious injury.
CAUTION	Indicates a hazardous situation which, if not avoided, could result in minor or moderate injury.
NOTICE	Indicates a hazardous situation not related to personal injury.

Within this IP, the safety label typically includes additional information such as the hazard type, a description of the damage that can be caused, and the steps that should be taken to avoid the hazard.

**WARNING****Personal Injury or Damage to Equipment**

*Failure to observe these safety precautions may result in personal injury or damage to equipment.*

- *Read and understand all instructions.*
- *Follow all warnings and instructions marked on this product.*
- *Installation and maintenance procedures must be followed and performed by trained personnel only.*
- *Grounding and circuit continuity is vital for safe operation of the equipment. Never operate the equipment with grounding/bonding conductor disconnected.*
- *Install only equipment identified in the product's installation manual. Use of other equipment may result in an improper connection which could lead to fire or injury.*
- *Use caution when installing or modifying telecommunications lines.*
- *The product has multiple power inputs. Before servicing, Disconnect all inputs to reduce the risk of energy hazards.*
- *For continued protection against risk of fire, all fuses used in this product must be replaced only with fuses of the same type and rating.*
- *Never install telecommunications wiring during a lightning storm.*
- *Never install telecommunications connections in wet locations.*
- *Never touch uninsulated telecommunications wiring or terminals unless the telecommunications line has been disconnected at the interface.*
- *Never push objects of any kind into the product through slots, as they may touch dangerous voltage points or short-out parts that could result in a fire or an electrical short.*
- *Never spill liquids of any kind on the product.*
- *Slots and openings in the product are provided for ventilation. To protect it from overheating, these openings must not be blocked or covered. The product should not be placed in a built-in installation unless proper ventilation is provided.*
- *To reduce the risk of an electrical shock, do not disassemble the product. Opening and removing covers and/or circuit boards may expose you to dangerous voltages or other risks. Incorrect reassembly can cause electrical shock when the unit is subsequently used.*

---

## Safety - specific hazards



### **DANGER**

#### **Lightning Strikes!**

*Lightning strikes are possible during stormy weather and could result in death or severe injury.*

*Do not work on the installation itself or on the power supply lines or antenna feeders of a 9927 during stormy weather.*



### **WARNING**

#### **Energy Hazard!**

*Some parts of all electrical installations are energized. Failure to observe this fact and the safety warnings may lead to bodily injury and property damage.*

*For this reason, only trained and qualified personnel may install or service the installation.*



### **WARNING**

#### **Energy Hazard!**

*The power supply lines to the network element are energized. Short circuits can cause burns to the face and hands.*

*Open the load disconnect switch in the distribution box to completely de-energize the network element.*

**WARNING****Beryllium Oxide Poisoning Hazard!**

*The transmitter units include components which contain beryllium oxide (BeO). In this form, BeO ceramics do not constitute a hazardous material as long as this material is not destroyed by external mechanical forces.*

*In the event that repair work is carried out by the customer or by third parties, the following regulations must be observed:*

- *Applicable version of the Regulation on Hazardous Materials in the Workplace*
- *Appropriate accident prevention regulations*

*The following must be specifically observed:*

- *Eating, drinking, and smoking are not permitted in workplaces where BeO ceramic components are being worked on.*
- *Wash your hands carefully under running water after working with BeO ceramic components.*

*If the following symptoms occur, contact a physician:*

- *Irritation of the respiratory organs*
- *Difficulty breathing or skin irritation*

**NOTICE****Condensation may cause a short circuit!**

*Sudden changes in the weather may lead to the formation of condensation on components. Operating the unit when condensation moisture is present can destroy the unit.*

*Units which show signs of condensation must be dried before installation.*

**NOTICE****ESD hazard**

*Semiconductor elements can be damaged by static discharges.*

*The following rules must be complied with when handling any module containing semiconductor components:*

- *Wear conductive or antistatic work clothes (for example, coat made of 100% cotton).*
- *Wear grounded ESD wrist strap.*
- *Wear shoes with conductive soles.*
- *Leave the modules in their original packaging until ready for use.*
- *Make sure there is no difference in potential between yourself, the workplace, and the package before removing, unpacking, or packing a module.*
- *Hold the module only by the grip without touching the connection pins, tracks, or components.*
- *Place modules removed from the equipment on a conductive surface.*
- *Test or handle the module only with grounded tools on grounded equipment.*
- *Handle defective modules exactly like new ones to avoid causing further damage.*

**DANGER****Cabinet lifting hazard!**

*When lifting cabinets, incorrect or improperly installed eyebolts will fail endangering personnel to bodily injury and destroying the equipment.*

*Avoid using the wrong eyebolts by following these guideline:*

- *If a 1/2-inch eyebolt threads easily and fully into a lifting nut on the top of the cabinet, then use the 1/2-inch eyebolts.*
- *If not, check the threads for 12 mm eyebolts. The 12 mm eyebolt should thread all the way down without binding, until it bottoms out.*
- *A 12-mm eyebolt is too small for a 1/2-inch lifting nut, but will not hand thread all the way into the 1/2-inch nut unless forced. It will cross thread if forced, and may pull out when hoisting, presenting a serious danger. Do NOT force 12-mm eyebolts into 1/2-inch lifting nuts. Doing so will damage the threads of the lifting nuts.*
- *A 1/2-inch eyebolt will thread less than half a thread into a 12-mm lifting nut. Do NOT force 1/2-inch eyebolts into 12-mm lifting nuts. Doing so will damage the threads of the lifting nuts.*

---

## Product safety

### Conformance statements

See [Appendix G, “Product conformance statements”](#) for all conformance statements that apply to this product.

### Equipment safety

Safety information for this equipment can be found on various Caution, Warning, Danger, information labels or instructions affixed to or included with the cabinet, its internal assemblies or included within this document. Informational and cautionary labels may appear near the item they address or may be grouped in a single location on the equipment. Warnings are typically adjacent to the hazard that is noted on the label. The instructions, cautions and warnings found on these labels must be understood and observed by all personnel involved with the equipment installation and maintenance.

**Important!** Refer to [“Structure of safety statements” \(p. 1-2\)](#) for definitions of safety labels.

### Equipment safety for 1900 MHz, 4x45W (65 MHz) RRH

The message below applies to the 1900 MHz, 4x45W (65 MHz) RRH.

**Important!** These units are intended for installation only in restricted access areas, where access can only be gained by trained service personnel and through the use of a tool, lock and key or other means of security, and where access is controlled by the authority responsible for the location



# 2 Product overview for 9927 Distributed Base Station Outdoor cabinet

## Overview

### Purpose

This chapter provides an overview of the 9927 Distributed Base Station Outdoor Cabinet.

### Contents

<a href="#">Network view</a>	2-2
<a href="#">Configurations</a>	2-3
<a href="#">Product overview</a>	2-4
<a href="#">Physical description</a>	2-6
<a href="#">Components inside cabinet</a>	2-13
<a href="#">Weights and dimensions of equipment</a>	2-14
<a href="#">60ECv2 battery cabinet overview</a>	2-19

---

## Network view

### Overview

The 9927 Distributed Base Station is a Multi-Technology, Multi-Band BTS that supports multiple access technologies. The RRHs are multi-functional and support both CDMA and LTE.

For CDMA, the MT-BBU interfaces with the RRHs via optical link.

The 1900 MHz (PCS) RRH operates in BC1 band and supports both LTE and CDMA.

The 800 MHz RRH operates in BC10 band and supports CDMA only.

The LTE RRH is hardware ready to support PCS in the G-Block.

LTE in the BC10 band is not supported in initial deployment.

Backhaul to the network is provided via the SAR-7705, either as:

- Fiber optic cable
- Microwave cable
- T1/E1 line
- OC3
- DS3

The -48 VDC power source inside the cabinet provides -48 VDC to the components inside the cabinet and to the RRHs.

### Signal flow block diagram

The high-level signal flow diagram below shows how signals flow within the Alcatel-Lucent 9927 Distributed Base Station outdoor cabinet and to the RRHs and Backhaul Network. (4G Backhaul is assumed to be available at the cell site.)

---

# Configurations

## Configurations

In FID 15364.0, the 9927 Distributed BTS supports the following configurations:

- Up to 4 carriers/3 sectors PCS (1x-A and EVDO) with 4-BR, if PCS RRH is shared with LTE [5 MHz on G block (band class 25)].
- Up to 1 carrier/3 sectors BC10 (1x-A) 2- BR .

If a higher CDMA carrier count is needed, a second PCS RRH may be required.

The 9927 Distributed BTS supports the following configurations:

- One MT-BBU, 8 Carriers/3 Sectors (4 Carriers 1x/1x Advance and 4 Carriers EVDO)
  - 3 BC1, 4x40W RRH with 4 branch Rx
  - 3 BC10, 2x50W RRH with 2 branch Rx
  - No daisy chaining
- One MT-BBU and one LTE BBU, 10 Carriers/3 Sectors (4 Carriers 1x/1x Advance and 4 Carriers EVDO)
  - 3 BC1, 4x40W LTE RRH with 4 branch Rx
  - 3 BC10, 2x50W RRH with 2 branch Rx
  - Daisy chaining

---

# Product overview

## Introduction

This document supports the following product:

- Alcatel-Lucent 9927 Distributed Base Station outdoor cabinet

## Product description for Alcatel-Lucent 9927 Distributed Base Station

The Alcatel-Lucent 9927 Distributed Base Station is a multi-modal baseband cabinet, configured with Remote Radio Heads (RRHs), which provides:

- CDMA in the PCS band (Bandclass 1 or 14) and 800 MHz band (Bandclass 10)
- Optional LTE in the PCS band (typically Block G). Resources are shared with CDMA.

The signal flow diagram below shows how CDMA, 1xEV-DO, and LTE signals are routed from the baseband cabinet to the RRHs. One sector is shown.

CDMA is processed by the Digital Shelf, which uses 9927 common platform architecture.

Backhaul to the Network is accomplished with T1/E1 lines, fiber optic cable, or microwave.

The RRHs that are used are as follows:

- 1900 MHz, 4x40W (25 MHz)
- 1900 MHz, 4x45W (65 MHz)
- 800 MHz, 2x50W

The cabinet is equipped with a top solar shield. See [Chapter 4, “Site configurations for 9927 Distributed BTS Outdoor Cabinet”](#) for line-up configurations.

## Requirements

The following table lists the requirements for the 9927 Distributed Base Station Outdoor Cabinet.

Requirements	Values
Frequency Bands	<ul style="list-style-type: none"><li>• 3GPP2 Band Class 1 (1900 MHz – United States PCS frequency band spectrum). Blocks A,B,C,D,E,F. [FID 15597.0]</li><li>• 3GPP2 Band Class 10 [FID 15599.0]</li><li>• PCS – G Block (band class 25) used only for LTE.</li></ul>
Operating Temperature	<ul style="list-style-type: none"><li>• -40 °C to +46 °C (-40 °F to +115 °F) standard</li><li>• -40 °C to 50 °C (-40 °F to 122 °F) extended</li></ul>

---

Requirements	Values
Power	Integrated Power
Battery backup	Up to two 60ECv2 battery cabinets
Operating Voltage	-48 VDC
Sectors	3,sector
T1/E1 Facilities	Up to 16 T1/E1s (optional)
User Alarms	32 for external User Alarms
GPS Antenna	Yes

---

## Physical description

### Diagram

The figure below shows the 9927 Distributed BTS outdoor cabinet with the front door closed.





The figure below illustrates the position of each component inside the 9927 Distributed BTS cabinet.

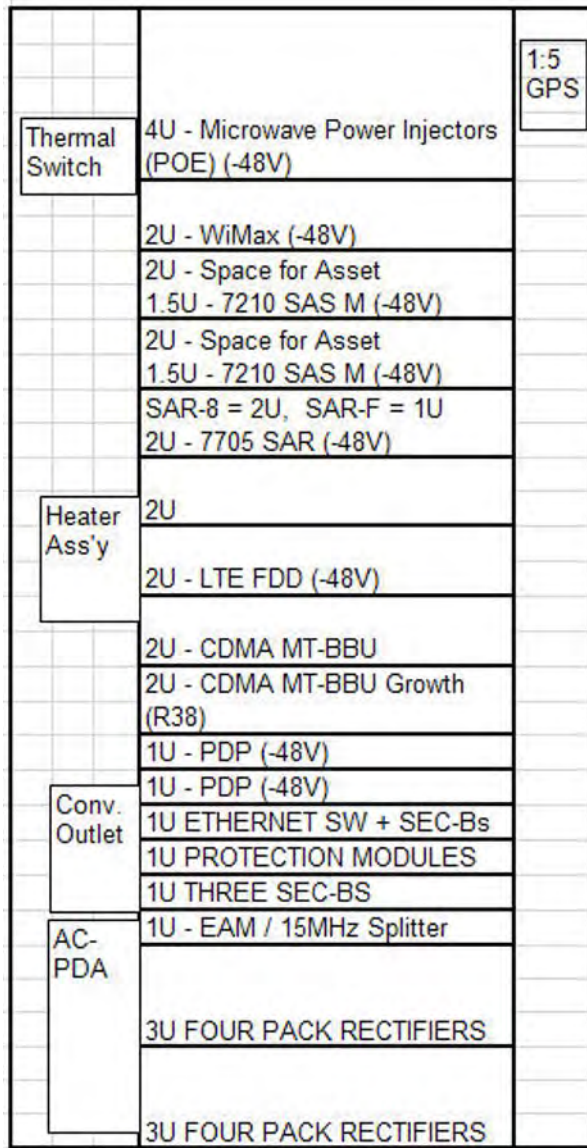



The following figure is a left-side view of the 9927 Distributed Base Station Outdoor Cabinet. The dimensions are shown in mm and inches.

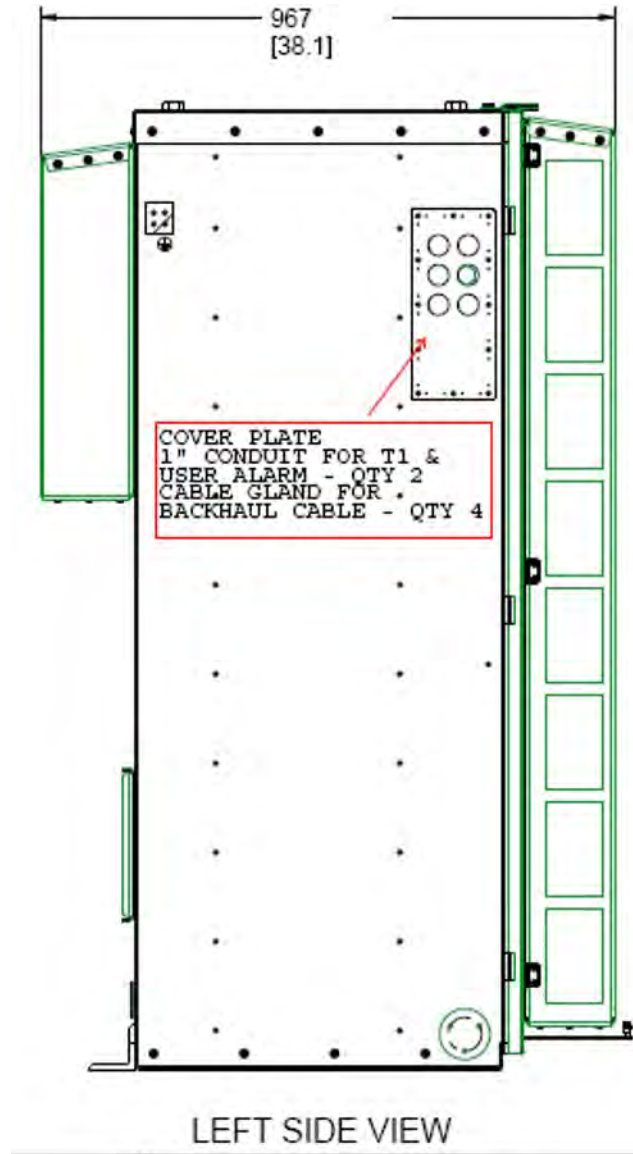

The following figure is a front view of the 9927 Distributed Base Station Outdoor Cabinet. The dimensions are shown in mm and inches.

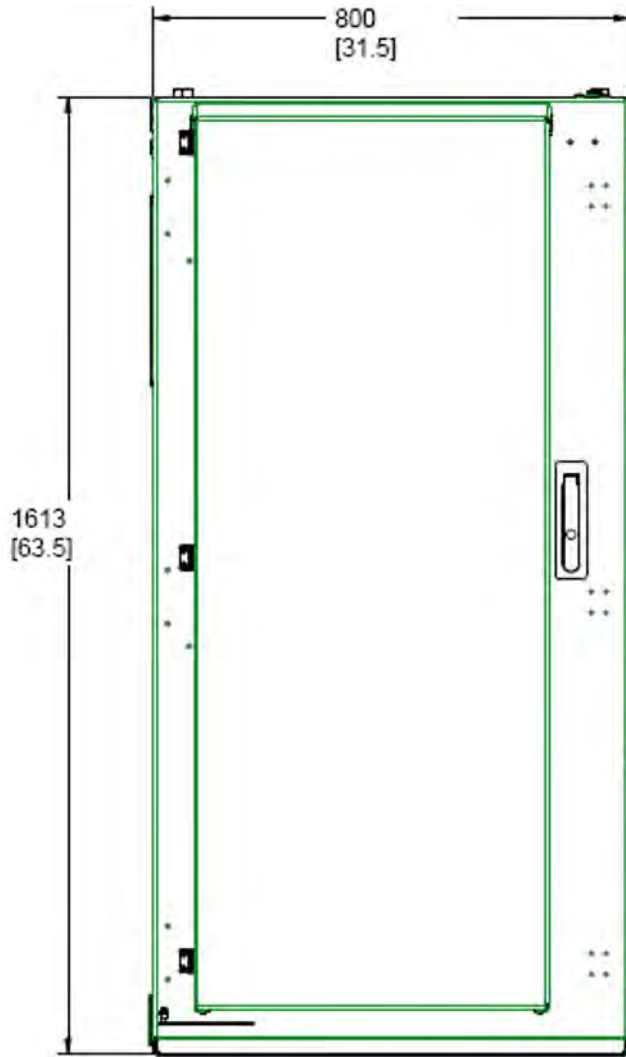

FRONT VIEW

The following figure is a right-side view of the 9927 Distributed Base Station Outdoor Cabinet. The dimensions are shown in mm and inches.

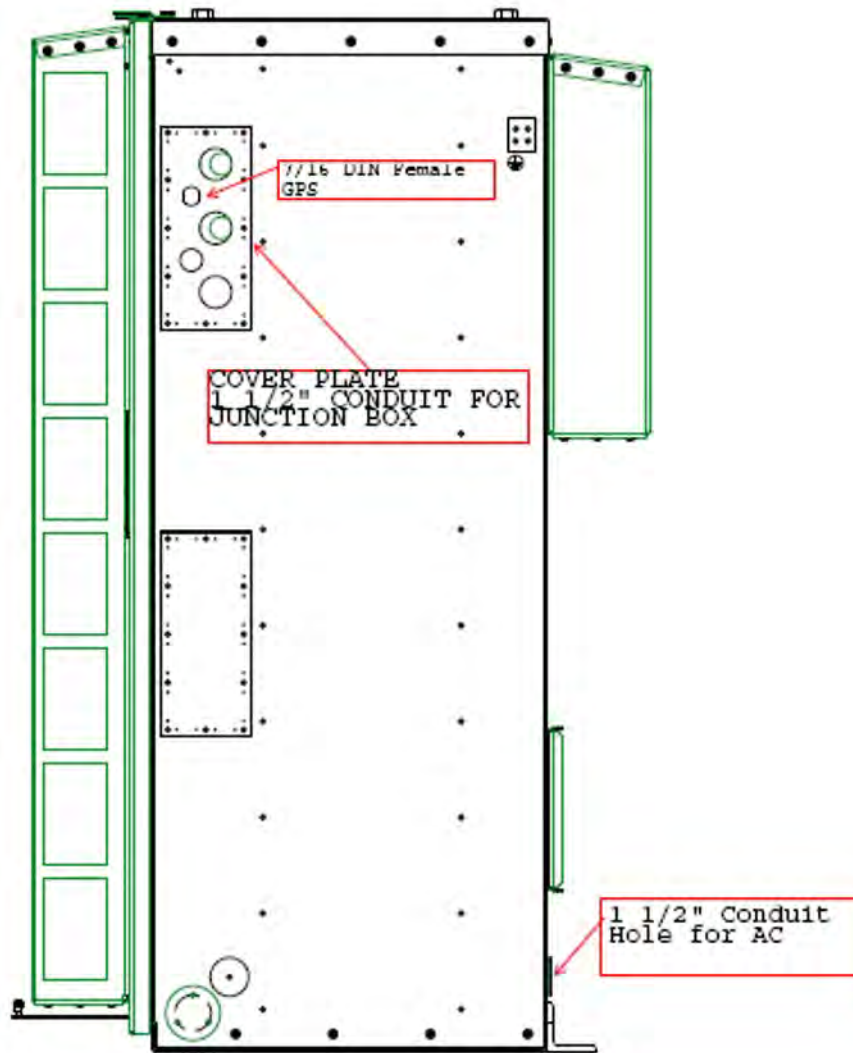

RIGHT SIDE VIEW

## Description

This 9927 Distributed Base Station Outdoor Cabinet features Fresh Air Cooling (FAC). The FAC uses filter membrane technology to achieve clean-room conditions inside the baseband cabinet.

---

The 9927 Distributed Base Station Outdoor Cabinet is equipped with the following features:

- Filter Life Alarm - The cabinet has a pressure sensing alarm that sends an alarm when more than the normal amount of suction is needed to draw air into the baseband cabinet.

The interior of the baseband cabinet is held at negative pressure (lower than ambient air pressure). All openings on the cabinet must be sealed to maintain negative pressure inside the baseband cabinet when the baseband cabinet is in operation.

**Important!** Refer to [Appendix D, “Guidelines for lifting and moving cabinets”](#) for guidelines regarding lifting and moving of the cabinet.

---

# Components inside cabinet

## Purpose

This section lists the components that can be populated in the 9927 Distributed Base Station Outdoor Cabinet.

## 9927 Distributed Base Station Outdoor Cabinet components

The table below lists the components inside the 9927 Distributed Base Station Outdoor Cabinet.

Components inside 9927 Distributed Base Station Outdoor Cabinet
---

The 9927 Distributed Base Station Outdoor Cabinet can contain the following modules:

- SAR 7705 SAR-8 (expandable) or 7705 SAR-F (fixed). 7705 SAR-M (future).
- Two 7210 SAS M (-48 VDC) -- only for microwave backhaul
- LTE TDD, 2.6 GHz (Optional) or
- CDMA MT-BBU
- CDMA MT-BBU Growth
- One or two -48 VDC PDPs -- second unit is optional. Needed only for cabinet is upgrade.
- 4-Position SEC-B Tray (ETSI) -- used only with T1/E1 Backhaul. T1/E1 Backhaul is via the SAR.
- Thermal Switch for Power Injectors
- Microwave Power Injector (PIB), -48 VDC
- ACPDA
- GFCI Convenience Outlet
- Heater Assembly
- User Alarm interface
- Alarms

## Weights and dimensions of equipment

### Introduction

This section provides physical specifications for one configuration of the 9927 Distributed Base Station Outdoor Cabinet.

The weights and dimensions, listed in the table below, include the top solar shield.

### 9927 Distributed Base Station Outdoor Cabinet weights and dimensions

The table below lists the weights and dimensions for a half-loaded and fully-loaded 9927 Distributed Base Station Outdoor Cabinet.

Cabinets	Configuration	Shipped Weight including pallet (estimate)	Maximum Installed Weight (estimate)	Reference Dimensions (Width x Depth x Height)
9927 Distributed Base Station Outdoor Cabinet with Integrated Power	Half loaded <ul style="list-style-type: none"> <li>CDMA</li> <li>One BBU</li> <li>One 7210</li> <li>One SAR 8</li> <li>Three DC-DC convertors</li> </ul>	470 kg (1033 lbs)	430 kg (945 lbs)	900 mm x 960 mm x 1925 mm (35.4 inches x 37.8 inches x 75.8 inches)
	Fully loaded <ul style="list-style-type: none"> <li>CDMA</li> <li>Four BBUs</li> <li>Two 7210s</li> <li>One SAR 8</li> <li>Six DC-DC convertors</li> <li>8 Injectors</li> </ul>	529 kg (1162 lbs)	489 kg (1074 lbs)	

### 60ECv2 battery cabinet weights and dimensions

The table below provides the weights and dimensions of the 60ECv2 battery cabinet.

Cabinets	Configuration	Shipped Weight including pallet (estimate)	Maximum Installed Weight (estimate)	Reference Dimensions (Width x Depth x Height)
60ECv2 Battery System	60ECv2 battery cabinet equipped with 20 12IR145 batteries	195 (430)	1284 (2830)	760x790x1500 (30 x 31 x 60)

---

## Component weights

The following table provides approximate weights for batteries and other miscellaneous hardware.

Item	Weight
12IR145 battery	45 kg (100 lbs)
KS24734 Rectifier	6 kg (14 lbs)
Pallet	40 kg (88 lbs)

---

### 9927 Distributed Base Station Outdoor Cabinet dimensions

The following figure is a left-side view of the 9927 Distributed Base Station Outdoor Cabinet. The dimensions are shown in mm and inches.

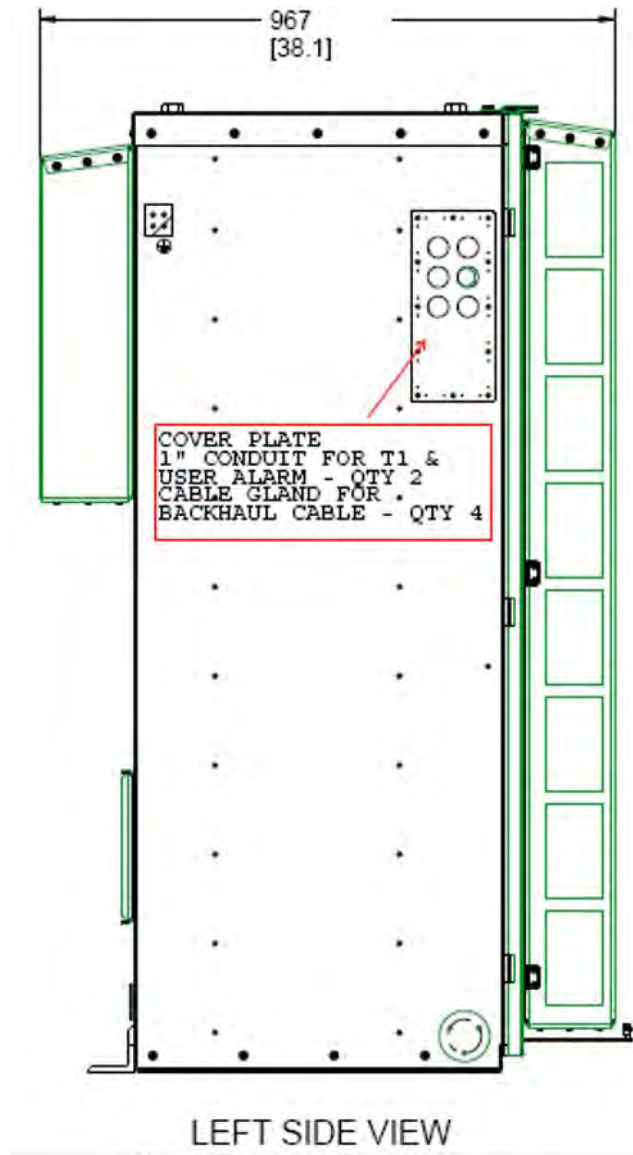



The following figure is a front view of the 9927 Distributed Base Station Outdoor Cabinet. The dimensions are shown in mm and inches.

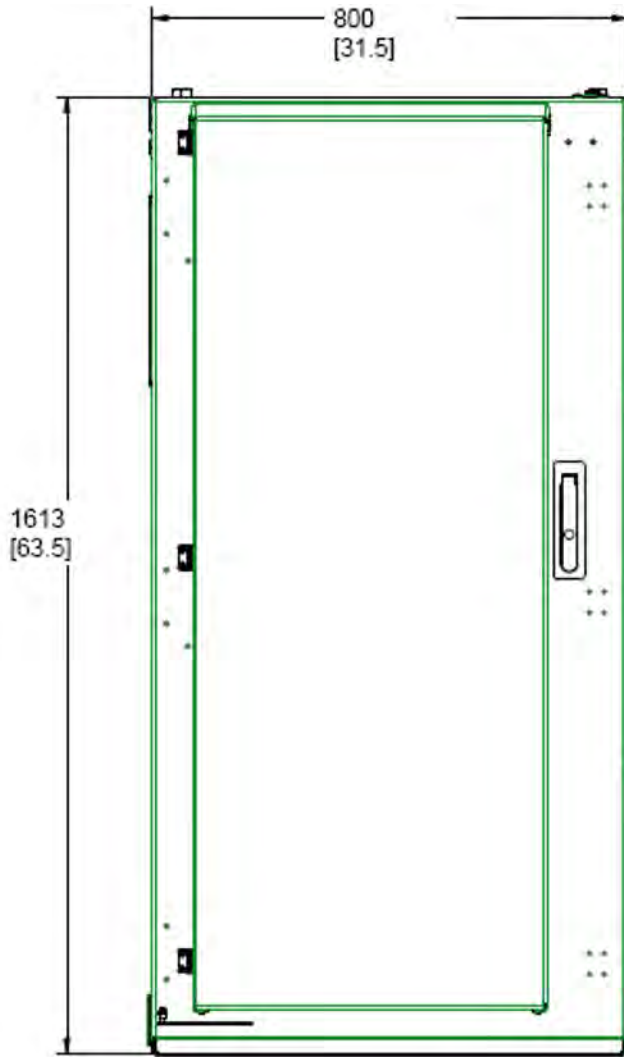

FRONT VIEW

The following figure is a right-side view of the 9927 Distributed Base Station Outdoor Cabinet. The dimensions are shown in mm and inches.

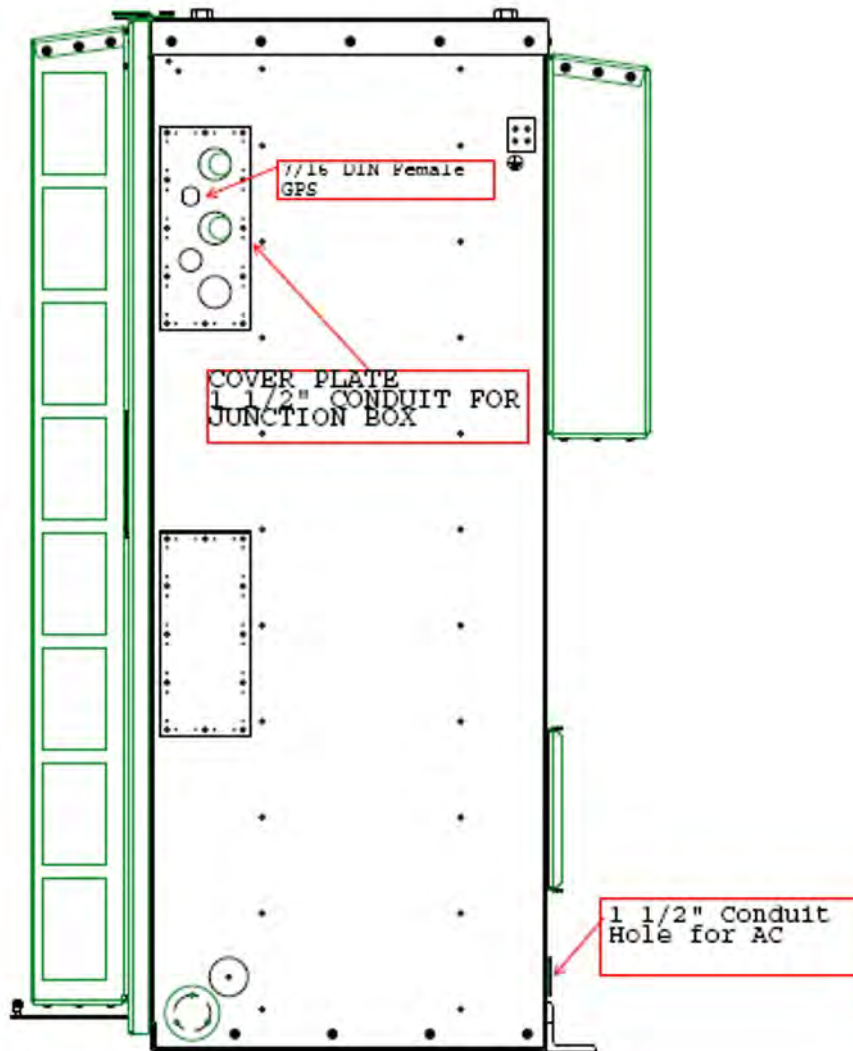

RIGHT SIDE VIEW

## 60ECv2 battery cabinet overview

### 60ECv2 description

This topic provides a description of the 60ECv2 battery cabinet.

The optional 60ECv2 battery cabinet provides battery backup for the 9927 Distributed Base Station Outdoor Cabinet. The 60ECv2 battery cabinet can contain up to (20) 12IR-145 batteries. Up to two 60ECv2 battery cabinets can be installed to the right of the 9927 Distributed Base Station Outdoor Cabinet.

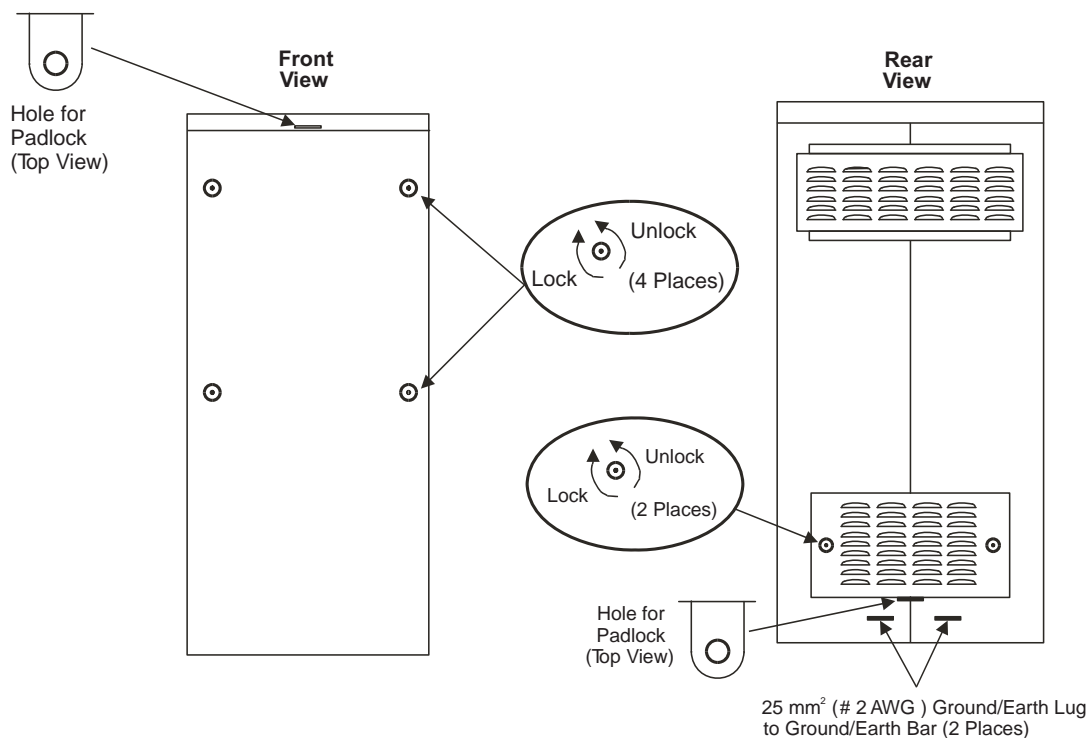



# 3 Product overview for RRHs

## Overview

### Purpose

This chapter provides an overview of the Alcatel-Lucent Remote Radio Head, with optional power and battery back up.

### Contents

Typical RRH/antenna array	3-2
External views of RRHs	3-3
Detailed physical description	3-6
Functional description of RRHs	3-18
Antenna Remote Electronic Tilt (RET) — FID 13019.36	3-19
RRH mounting configurations	3-20
RRHs and related equipment	3-23

---

## Typical RRH/antenna array

### Typical RRH/antenna arrays on tower

The figure below shows a typical RRH/antenna array on a tower.



---

## External views of RRHs

### Orthogonal view of 1900 MHz, PCS, 4x40W (25 MHz) RRH

The following figure is an orthogonal view of the 1900 MHz, PCS, 4x40W (25 MHz) RRH. Dimensions are shown in mm.

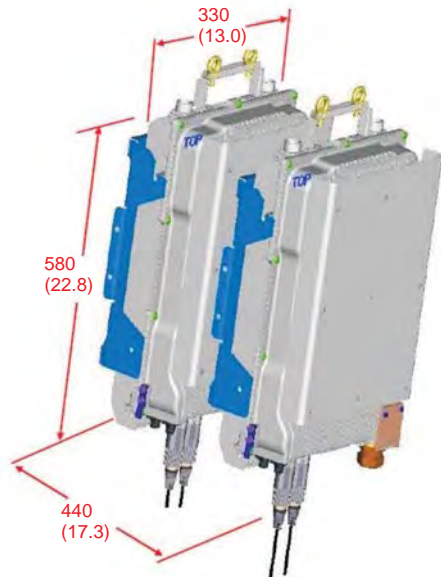

---

**Orthogonal view of 1900 MHz, PCS, 4x45W (65 MHz) RRH**

The following figure is an orthogonal view of the 1900 MHz, PCS, 4x45W (65 MHz) RRH. Dimensions are shown in mm.

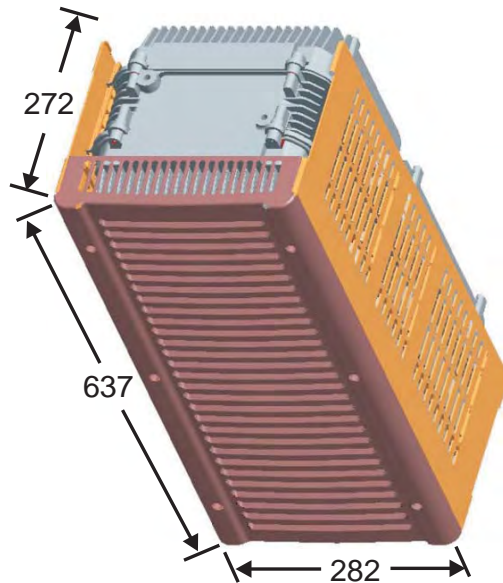

**Orthogonal view of 800 MHz, 2x50W RRH (OEM1)**

The following figure is an orthogonal view of the OEM1, 800 MHz, 2x50W RRH. Dimensions are shown in mm.

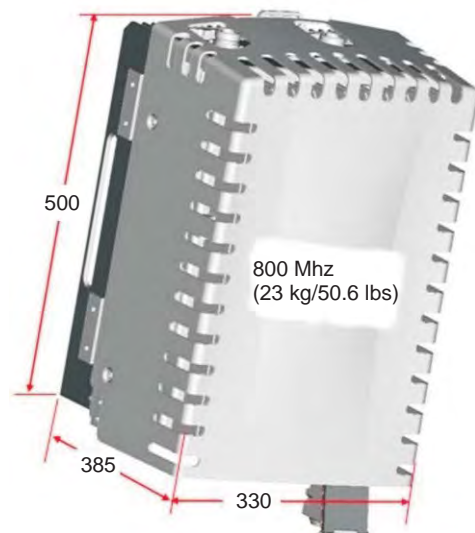



---

**Orthogonal view of 800 MHz, 2x50W RRH (OEM2)**

The following figure is an orthogonal view of the OEM2, 800 MHz, 2x50W RRH. Dimensions are shown in mm.

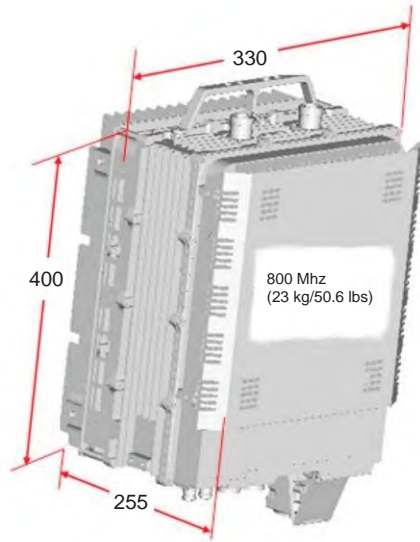

## Detailed physical description

### Identify RRHs according to front, top and bottom views

Use the table below to identify each RRH using the front, top and bottom views.

Front, top and bottom views of RRHs-- for identification			
Frequency	Front View	Top View	Bottom View
1900 MHz PCS	Refer to “Front view of 1900 MHz, PCS, 4x40W (25 MHz) RRH” (p. 3-7)	Refer to “Top view of 1900 MHz, PCS, 4x40W (25 MHz) RRH ” (p. 3-8)	Refer to “Bottom view of 1900 MHz, PCS, 4x40W (25 MHz) RRH ” (p. 3-9)
1900 MHz PCS 4X45W, 65 MHz	Refer to “Front view of 1900 MHz, PCS, 4x45W (65 MHz) RRH” (p. 3-10)	Refer to “Top view of 1900 MHz, PCS, 4x45W (65 MHz) RRH ” (p. 3-11)	Refer to “Bottom view of 1900 MHz, PCS, 4x45W (65 MHz) RRH ” (p. 3-12)
OEM1, 800 MHz, 2x50W	Refer to “Front view of OEM1, 800 MHz, 2x50W RRH” (p. 3-13)	Refer to “Top view of OEM1, 800 MHz, 2x50W RRH” (p. 3-13)	Refer to “Bottom view of OEM1, 800 MHz, 2x50W RRH” (p. 3-14)
OEM2, 800 MHz, 2x50W	Refer to “Front view of OEM2, 800 MHz, 2x50W RRH” (p. 3-14)	Refer to “Top view of OEM2, 800 MHz, 2x50W RRH” (p. 3-15)	Refer to “Bottom view of OEM2, 800 MHz, 2x50W RRH” (p. 3-15)

---

**Front view of 1900 MHz, PCS, 4x40W (25 MHz) RRH**

The following figure is a front view of the 1900 MHz PCS, 4x40W (25 MHz) RRH.

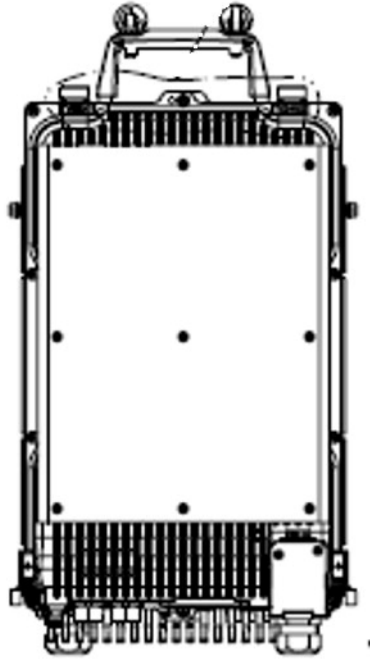

---

**Top view of 1900 MHz, PCS, 4x40W (25 MHz) RRH**

The following figure is a top view of the 1900 MHz PCS, 4x40W (25 MHz) RRH.

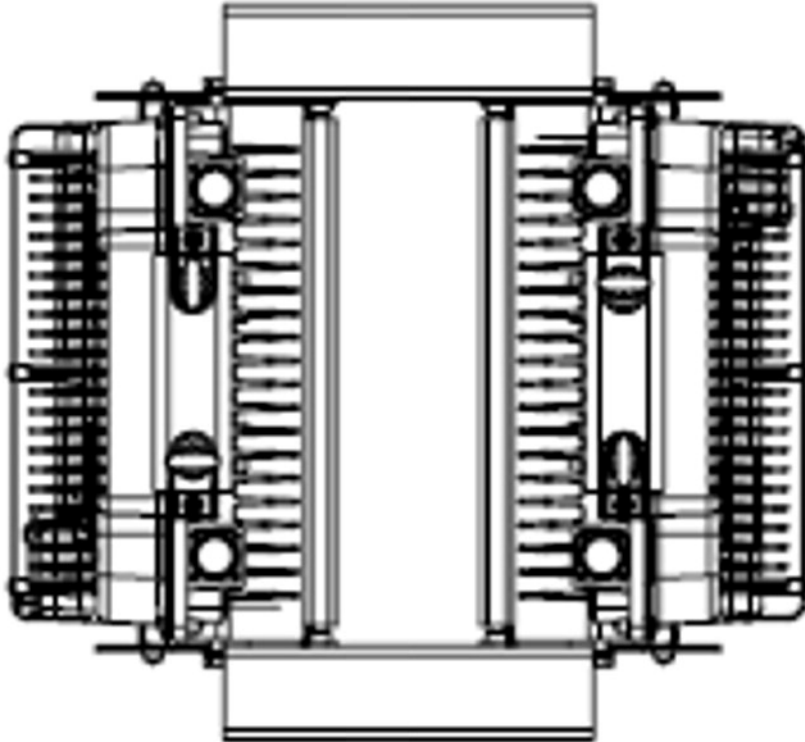

---

**Bottom view of 1900 MHz, PCS, 4x40W (25 MHz) RRH**

The following figure shows the connectors on the bottom of the 1900 MHz, PCS, 4x40W (25 MHz) RRH.

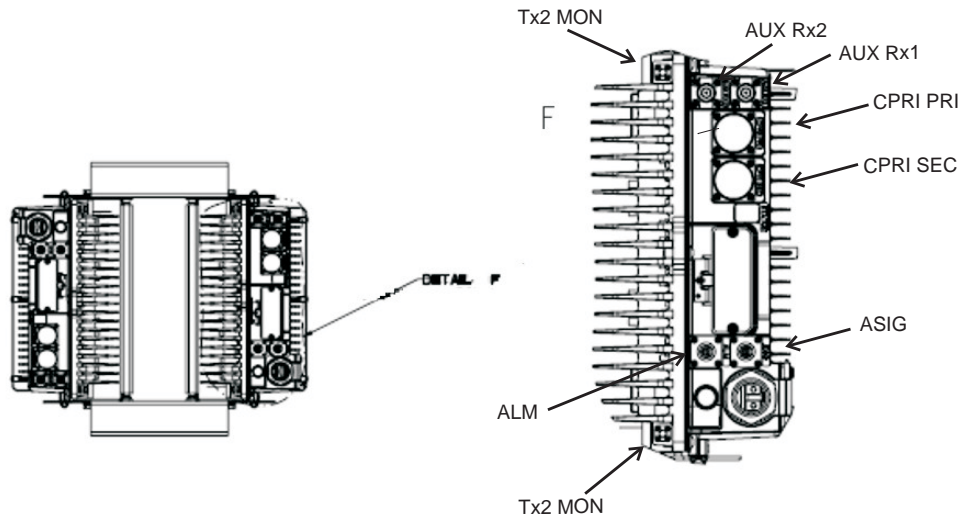

---

**Front view of 1900 MHz, PCS, 4x45W (65 MHz) RRH**

The following figure is a front view of the 1900 MHz, PCS, 4x45W (65 MHz) RRH.



---

**Top view of 1900 MHz, PCS, 4x45W (65 MHz) RRH**

The following figure is a top view of the 1900 MHz, PCS, 4x45W (65 MHz) RRH.

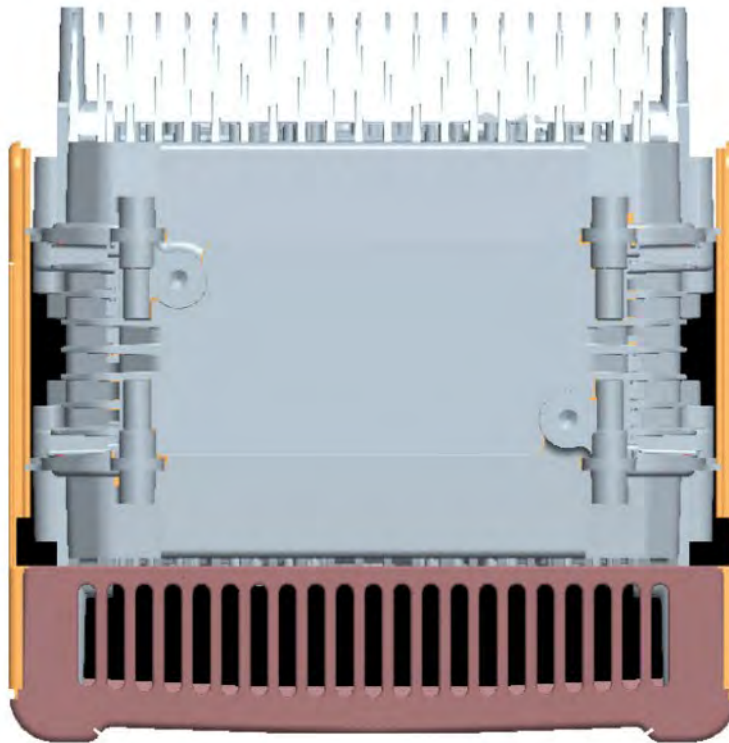

---

**Bottom view of 1900 MHz, PCS, 4x45W (65 MHz) RRH**

The following figure shows the connectors on the bottom of the 1900 MHz, PCS, 4x45W (65 MHz) RRH.

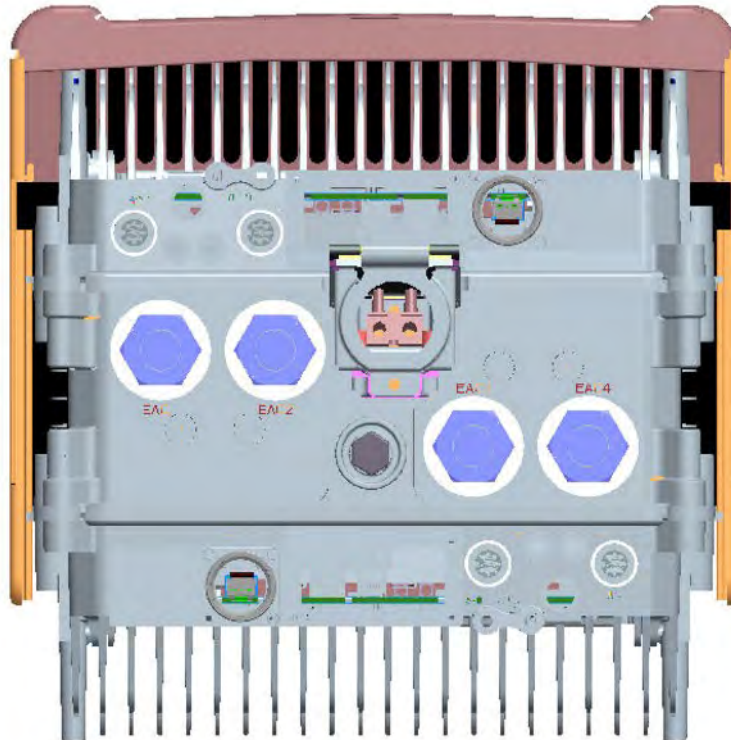



---

**Front view of OEM1, 800 MHz, 2x50W RRH**

The following figure is a front view of the OEM1, 800 MHz, 2x50W RRH.

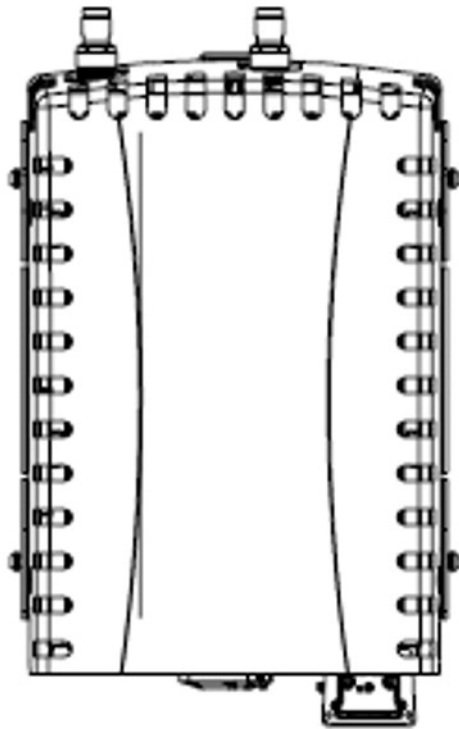

**Top view of OEM1, 800 MHz, 2x50W RRH**

The following figure is a top view of the OEM1, 800 MHz, 2x50W RRH.

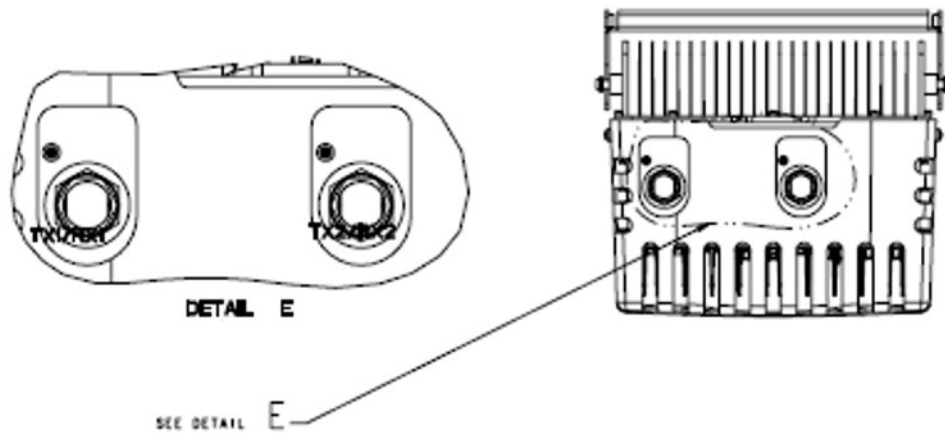

---

**Bottom view of OEM1, 800 MHz, 2x50W RRH**

The following figure is a bottom view of the OEM1, 800 MHz, 2x50W RRH.

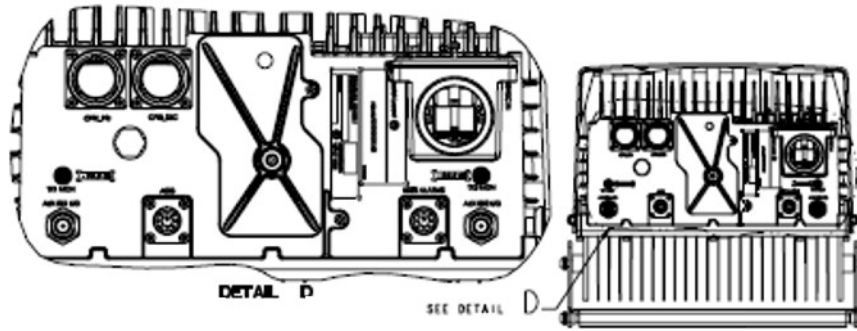

**Front view of OEM2, 800 MHz, 2x50W RRH**

The following figure is a front view of the OEM2, 800 MHz, 2x50W RRH.

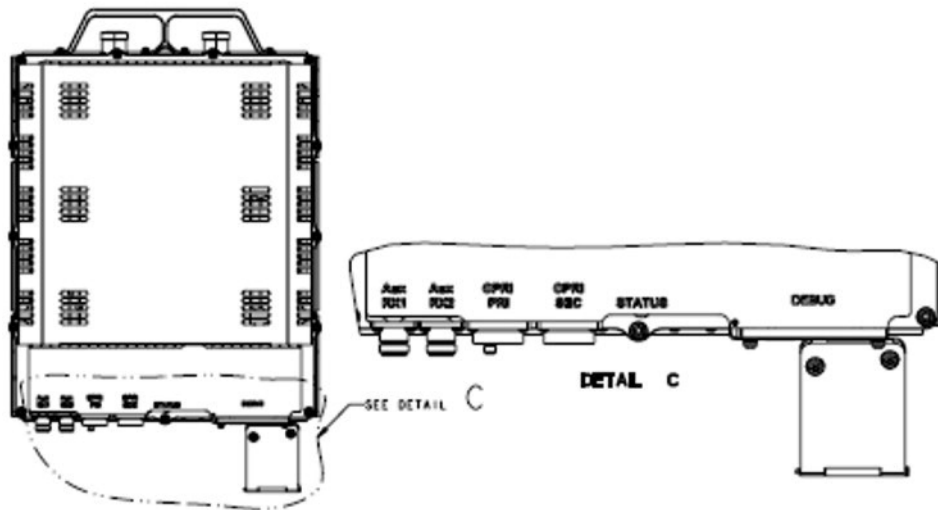

**Top view of OEM2, 800 MHz, 2x50W RRH**

The following figure is a top view of the OEM2, 800 MHz, 2x50W RRH.

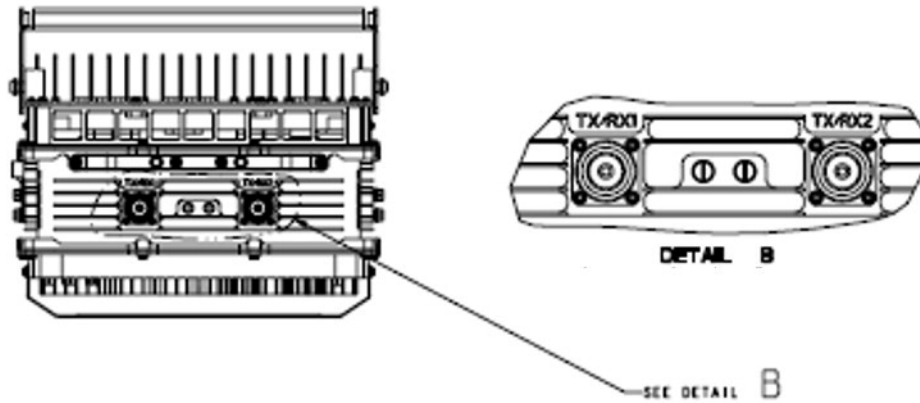

**Bottom view of OEM2, 800 MHz, 2x50W RRH**

The following figure shows the connectors on the bottom of the OEM2, 800 MHz, 2x50W RRH.

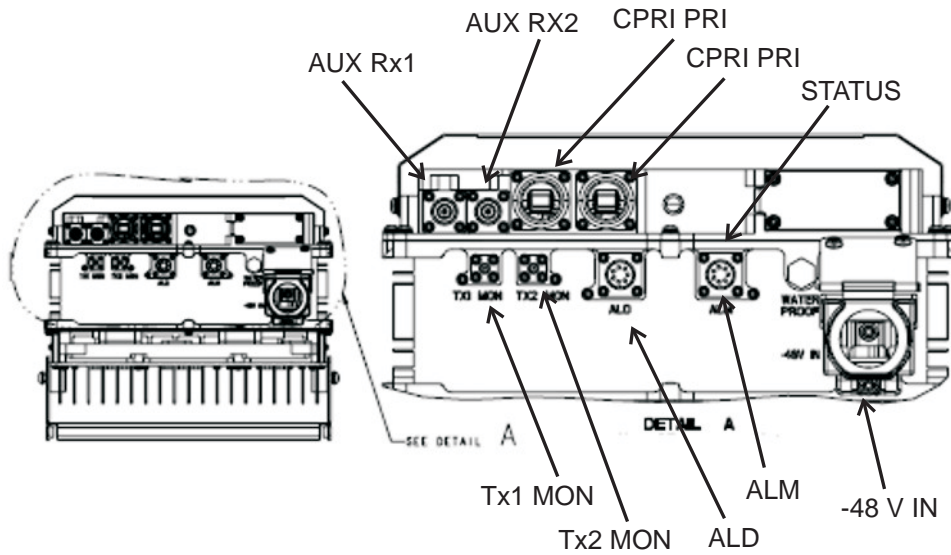

**Bottom view of 1900 MHz, 4x40W (65 MHz) RRH**

Get figs from attachment!

## Connectors on 1900 MHz RRH

The following table lists the connectors on the 1900 MHz RRH and the function of each connector.

### Connectors on 1900 MHz RRH

Connector	Function
TX1/RX1 (25 MHz — top of RRH/ 65 MHz — bottom of RRH)	Transmit and receive, antenna path 1
TX2/RX2 (25 MHz — top of RRH/ 65 MHz — bottom of RRH)	Transmit and receive, antenna path 2
TX3/RX3 (25 MHz — top of RRH/ 65 MHz — bottom of RRH)	Transmit and receive, antenna path 3
TX4/RX4 (25 MHz — top of RRH/ 65 MHz — bottom of RRH)	Transmit and receive, antenna path 4
Grounding Points (on left and right side of 25 MHz RRH) <a href="#">RRH grounding points</a> [Left and Right for 25 MHz / Bottom for 65 MHz]	Connect 6 AWG (outdoor) or 2 AWG (indoor) ground wire terminated with 2-hole lug to RRH.
AUX RX1	Antenna-sharing port
AUX RX2	N/A
CPRI PRI	CPRI optical main port
CPRI SEC	CPRI optical daisy-chained port
AISG	Remote Electronic Tilt (RET)
ALM	2 x 8 pin circular
TX1 MON	
TX2 MON	
-48 V	

## RRH connectors on OEM2 RRH

The following table lists the connectors on the OEM2 RRH and the function of each connector.

### Connectors on OEM2 RRH

Connector	Function
TX/RX1 (at top of RRH)	Transmit and receive, antenna path 1
TX/RX2 (at top of RRH)	Transmit and receive, antenna path 2

---

Connector	Function
Grounding Points (on left and right sides of RRHs) <a href="#">RRH grounding points</a>	Grounding point
AUX RX1	Antenna-sharing port
AUX RX2	Antenna-sharing port
CPRI PRI	CPRI optical main port
CPRI SEC	CPRI optical daisy-chained port
STATUS	
ALM	2 x 8 pin circular
TX1 MON	
TX2 MON	
ALD	
-48 V IN	-48 VDC input power

---

# Functional description of RRHs

## General description

The three RRHs pictured below are used with 800 MHz CDMA, PCS CDMA, and LTE technologies.

## Product configurations

The configurations offered in this release are as follows:

- One sector (consists of two 1900 MHz RRHs and one 800 MHz RRH per sector)

## Product capabilities

The product capabilities for the RRHs are as follows:

- 1900 MHz
  - PCS CDMA
  - LTE
  - Outdoor, -48 VDC
- 800 MHz
  - CDMA
  - Outdoor, -48 VDC

---

## Antenna Remote Electronic Tilt (RET) – FID 13019.36

### General description

FID-13019.36 introduces a Remote Radio Head (RRH) with an associated RET/ALD controller that operates the RET.

The RET consists of an actuator motor with supporting control electronics. The RET adjusts the antenna down-tilt angle by electrically changing the antenna phase angle. By altering the phase of the antenna signal, the RET also tilts the antenna beam.. This results in decreased main, side and backward lobes. This overcomes the shortcomings of mechanical tilt antennas, where the whole antenna is physically tilted. This system moves the backward lobe in upward direction and distorts the side-lobe patterns.

### AISG interface on RRH

The RRHs are equipped with an Antenna Interface Standards Group (AISG) power and signaling interface connector that supports third party Antenna Remote Electronic Tilt (RET) equipment. The PCS RRH 4x and 800 MHz RRH 2x are hardware ready to support the third party RET.

---

## RRH mounting configurations

### RRH mounting configurations

The RRHs can be mounted on a:

- Pole
- Wall
- Floor Stand.

### Pole mounted RRHs

The following figure shows the 800 MHz/1900 MHz RRH configuration mounted on a pole. The 800 MHz RRH is mounted directly above the 1900 MHz RRH. Each RRH is equipped with a lifting handle. The antenna assembly is mounted opposite the RRHs.

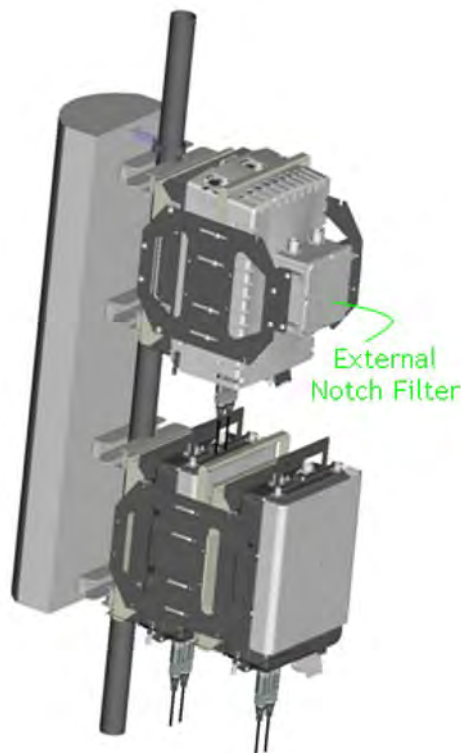

### Wall mounted RRHs

The following figure shows a typical RRH mounted on a wall with Unitstruts.





### Floor Stand mounted RRHs [800 MHz and 4x40W (25 MHz) PCS]

The following figure shows the floor stand that is used with 800 MHz and 4x40W (25 MHz) PCS RRHs. The wall mounting bracket is shown attached.





## RRHs and related equipment

### Weights and dimensions

This topic covers the weights and dimensions for RRHs and related equipment.

### Weights and dimensions of RRHs and accessories

The following table provides weights and dimensions for the RRHs and floor stand.

RRH type or accessory	Description	Estimated maximum installed weight without mounting brackets kg (lbs)	Height mm (inches)	Width mm (inches)	Depth mm (inches)
RRH, 800 MHz, OEM1	CDMA/LTE, Dual Technology, 2 x 50 Watts	23 (50.6)	500 (19.7)	330 (13.0)	385 (15.2)
RRH, 800 MHz, OEM2		23 (50.6)	400 (15.8)	330 (13.0)	255 (10.0)
RRH, 1900 MHz, 25 MHz per Tx port	CDMA/LTE, Dual Technology, 4 x 40 Watts	47 (104) [includes 2 RRHs and mounting brackets]	580 (22.8)	330 (13.0)	440 (17.3)
RRH, 1900 MHz, 65 MHz per Tx port	CDMA/LTE, Dual Technology, 4 x 45 Watts	60 (132)	637 (25.1)	282 (11.1)	272 (10.7)
Notch Filter		4 (8.8)			
Floor Stand	n/a	23 (51)	509 (20.1)	360 (14.2)	1226 (48.3)

### Miscellaneous hardware weights

The following table provides approximate weights for miscellaneous hardware.

Item	Weight kg (lbs)
Pallet	___ (___)
Wall Bracket (RRH)	3.5 (7.7)
Side Support Bracket	3.5 (7.7)
Pole Bracket (Low Profile)	4.3 (9.5)

---

Item	Weight kg (lbs)
Floor Stand (RRH)	23 (50)

### Grounding points on RRHs

The grounding points on the 1900 MHz and 800 MHz RRHs are located at the bottom, on the left and right sides.

The following figure shows how grounding wire is routed to the RRHs.

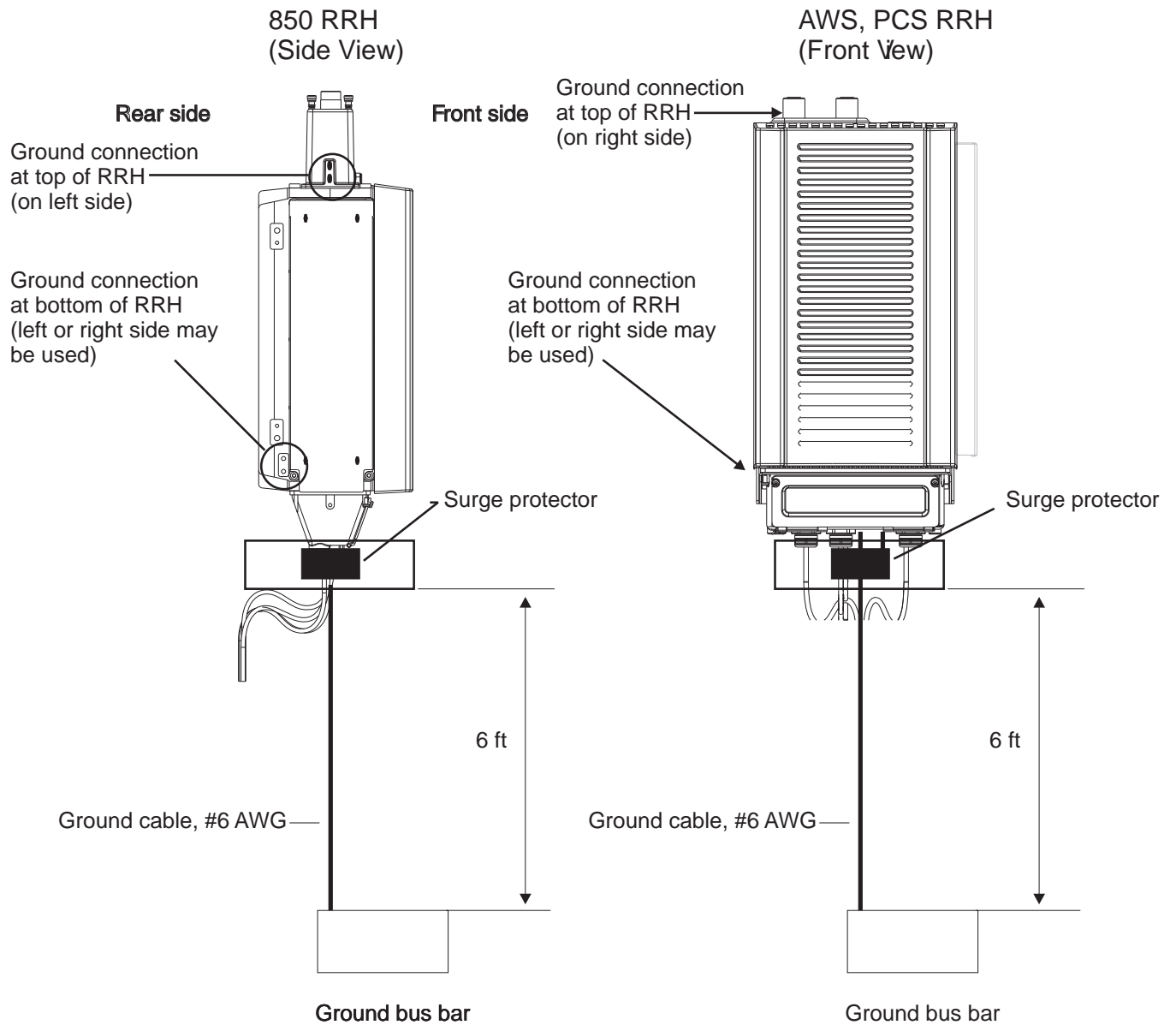

Note: For antenna sharing 850, AWS, PCS RRHs, ground connection for surge protector must be within 6 feet of a ground bus bar.

The following figures show the grounding points on the OEM2 RRH.

The left-side grounding point on the OEM2 RRH is located at the left bottom, as shown in the figure below.

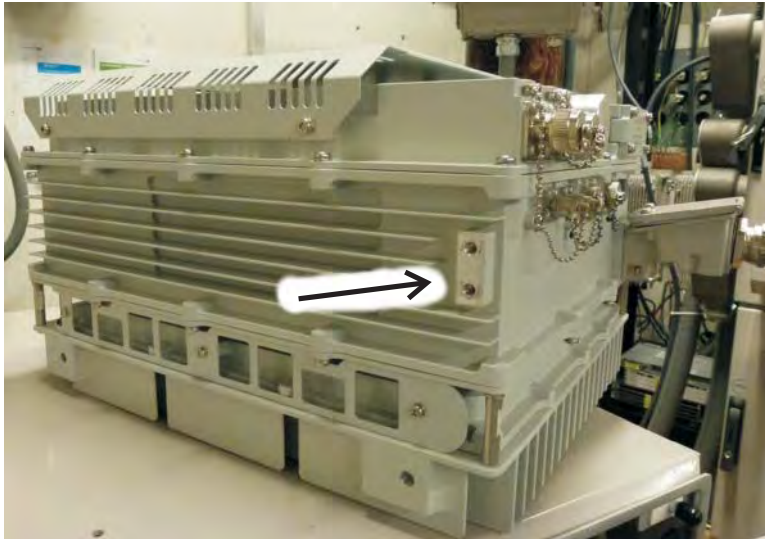

The right-side grounding point on the OEM2 RRH is located at the right bottom, as shown in the figure below.

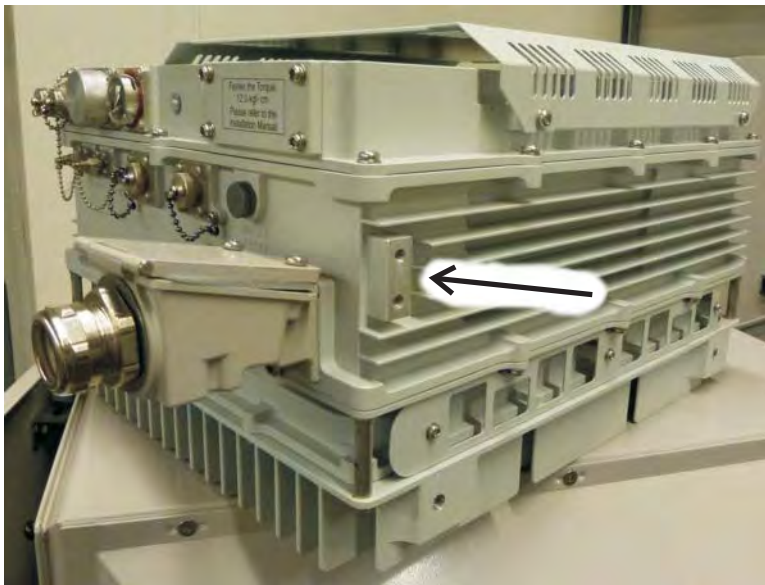

The following figures show the grounding points on the 1900 MHz RRH.

The left-side grounding point on the 1900 MHz, 4x40W RRH is located at the left bottom, as shown in the figure below.

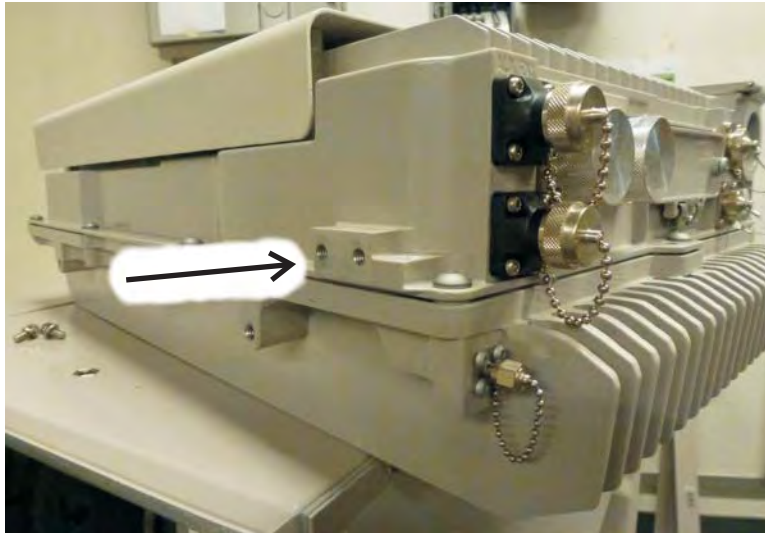

The right-side grounding point on the 1900 MHz, 4x40W RRH is located at the right bottom, as shown in the figure below.

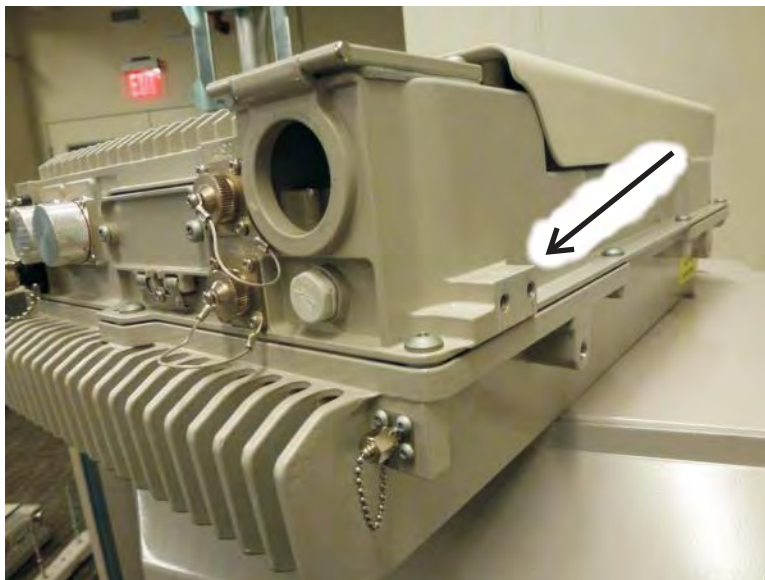

The following figures shows the grounding points on the 1900 MHz, 4x45W RRH.

---

The grounding points on the 1900 MHz, 4x45W RRH are located on the bottom, as shown in the figure below.

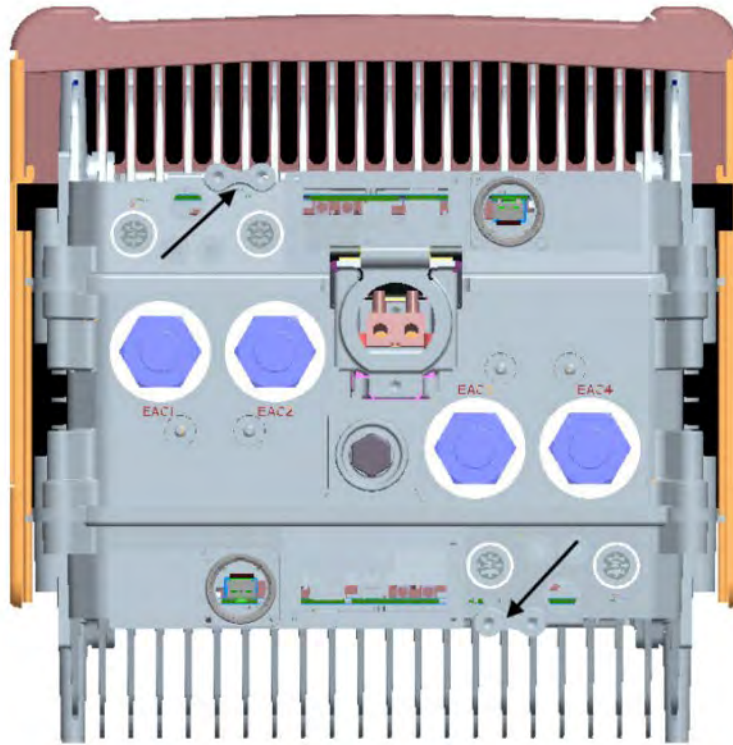



# 4 Site configurations for 9927 Distributed BTS Outdoor Cabinet

## Overview

### Purpose

This chapter describes configurations and site layouts for the 9228 Distributed Base Station site.

### Contents

<b>Line-up configuration</b>	<b>4-2</b>
Line-up configuration	4-3
<b>Site layout</b>	<b>4-4</b>
9927 Distributed Base Station Outdoor Cabinet site layout	4-5

# Line-up configuration

## Overview

### Purpose

This section discusses the line-up configuration for the 9927 Distributed Base Station Outdoor Cabinet.

### Contents

<a href="#">Line-up configuration</a>	4-3
---------------------------------------	-----

# Line-up configuration

## Purpose

This section describes the only line-up that is available for the 9927 Distributed Base Station Outdoor Cabinet.

## Line-up

At the present time, the only line-up available for the 9927 Distributed Base Station Outdoor Cabinet consists of the 9927 Distributed Base Station Outdoor Cabinet and up to two 60ECv2 battery cabinets.

The block diagram below shows the line-up for the 9927 Distributed Base Station Outdoor Cabinet and two 60ECv2 battery cabinets.

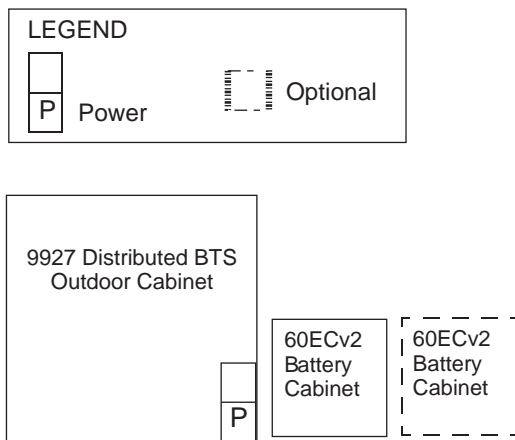

# Site layout

## Overview

### Purpose

This section shows the site layout for the 9927 Distributed Base Station Outdoor Cabinet.

### Contents

<a href="#">9927 Distributed Base Station Outdoor Cabinet site layout</a>	4-5
---	-----

---

# 9927 Distributed Base Station Outdoor Cabinet site layout

## Purpose

This section shows how the 9927 Distributed Base Station Outdoor Cabinet and two 60ECv2 battery cabinets can be arranged on a concrete pad.

## Mounting options

The 9927 Distributed Base Station Outdoor Cabinet can be mounted in the following manner:

- On a concrete pad (with optional mounting bases)
- On a rooftop (may be supported by a mounting structure or raised platform provided by the customer)

## New site installation of 9927 Distributed Base Station Outdoor Cabinet

### 9927 Distributed Base Station Outdoor Cabinet and two 60ECv2 battery cabinets

The figure below shows how the 9927 Distributed Base Station Outdoor Cabinet and two 60ECv2 battery cabinets can be situated on a concrete pad. Shown also are the conduits, cables, and support structure associated with the installation. (This configuration applies to a new site installation.)

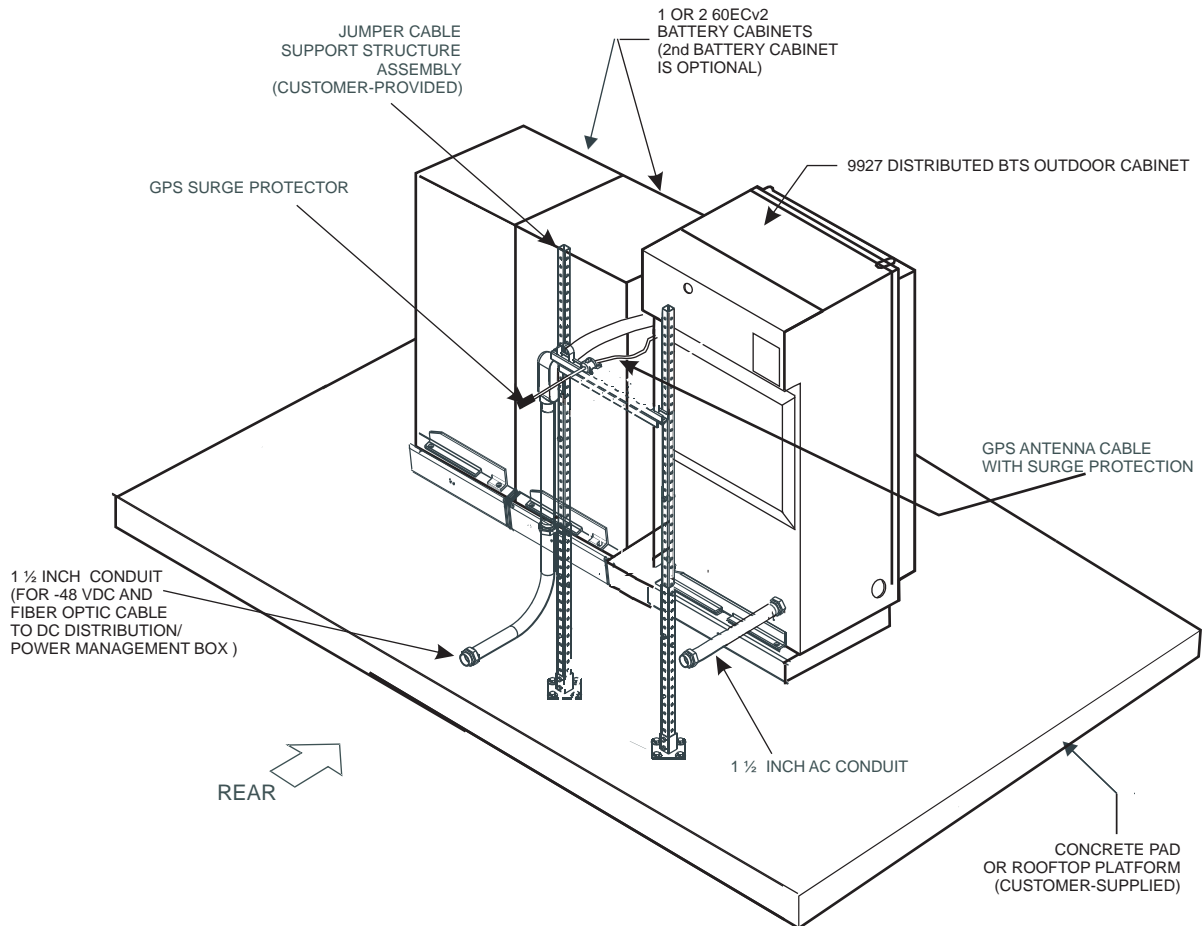

# 5 Basic site preparation requirements and footprints for 9927 Distributed Base Station outdoor cabinet

---

# Overview

## Purpose

This chapter provides the site requirements for the installation site for 9927 Distributed Base Station Outdoor Cabinet and the procedures that may be performed to prepare the installation site.

## Contents

<b>Site requirements for 9927 Distributed Base Station Outdoor cabinet</b>	<b>5-3</b>
Environmental requirements	5-4
Site requirements	5-6
Mounting options	5-9
Support structure, ice bridge and service access clearances	5-11
Anchoring requirements	5-12
Anchoring footprints	5-13
<b>Site preparation procedures</b>	<b>5-15</b>
Drill anchor holes	5-16



---

# Site requirements for 9927 Distributed Base Station Outdoor cabinet

## Overview

### Purpose

This section describes the requirements for the installation site for the 9927 Distributed Base Station Outdoor Cabinet.

### Contents

Environmental requirements	5-4
Site requirements	5-6
Mounting options	5-9
Support structure, ice bridge and service access clearances	5-11
Anchoring requirements	5-12
Anchoring footprints	5-13

## Environmental requirements

### Environmental requirements for outdoor installations

Outdoor cabinet installations are exposed to variations in temperature, humidity, and ventilation.

The 9927 Distributed Base Station cabinet has been weather-hardened. When equipped with a heat exchanger, the cabinet will operate under the conditions described in the table below.

Condition	Specification
Operating temperature	-40 °C to +46 °C (-40 °F to +115 °F)
Extended operating temperature	-40 °C to 50 °C (-40 °F to 122 °F)
Relative humidity	5 to 100% (non-condensing but not to exceed 0.024 kg water/kg of dry air)
Enclosure rating	Type 3R (NEMA) IP35 (IEC 60529)
Acoustic noise suppression	65 dBA at 25 °C (77 °F) and sea level
Operating altitude	-60.96 to 1798 m (-200 to 5,900 ft.) above sea level
Extended operating altitude	-60.96 to 3048 m (-200 to 10,000 ft.). An operating temperature de-rating of 1 °C per 1000 feet above 6000 feet is allowed
Wind driven rain	Refer to Telcordia GR-487-CORE
Dust and water ingress	Refer to Telcordia GR-487-CORE
Bullet resistance	Refer to Telcordia GR-487-CORE
Wind resistance	Refer to Telcordia GR-487-CORE
Storage requirements	Refer to Telcordia GR-63-CORE, Section 4.1.1

### Minimum installation temperatures

Insulation on power cables tends to crack when handled at extremely cold temperatures. Minimum installation temperatures have been established for this reason.

The following wire insulation types are affected :

- Class B: THHN type insulation (T90 NYLON type insulation in Canada).

The minimum storage and working temperatures are as follows:

- Storage prior to installation: 20 °C (68 °F)
- Working (Installation): -25 °C (-13 °F)

**Installations at -25 °C (-13 °F) or below**

If shelter is available, do the following:

- Store cables in a heated area (20 °C [68 °F] or higher) for 24 hours prior to installation.
- Keep cables sheltered from wind and temperatures below -25 °C (-13 °F) during installation.
- It is recommended to perform the installation in a heated tent.

If shelter cannot be provided, the following cable along with the associated hardware is recommended. The size of the cable determines the correct tool to use, as well as the inside diameter of the lug and the insulating sleeve.

- Industrial Wire & Cable Corp. Type MTW Machine Tool Wire
- FCI Terminal Lug (or equivalent), 3/8" Bolt Size, Straight, 2-Hole, 1" Center to Center
- FCI Terminal Lug (or equivalent), 1/4" Bolt Size, Straight, 2-Hole, 5/8" Center to Center
- FCI Terminal Lug (or equivalent), 5/16 Bolt Size, Straight, One-Hole
- Panduit (or equivalent) Type HSTTV 75-T2 Insulating Sleeve, Heat Shrink, Red
- Panduit (or equivalent) Type HSTTV 75-T Insulating Sleeve, Heat Shrink, Black

## Site requirements

### General requirements

The following general requirements must be met before the installation of the 9927 Distributed Base Station site can be started:

- An appropriate installation site must be selected. For more information, see [“Mounting options”](#) (p. 5-9).
- Adequate clearance must be provided for service access, as described in [“Support structure”](#) (p. 5-11).
- The environment must comply with [“Environmental requirements for outdoor installations”](#) (p. 5-4).
- Cabinet anchor holes must be drilled, as described in [“Drill anchor holes”](#) (p. 5-16).
- Support structure and ice bridge (if required) must be installed, as described in [“Support structure, ice bridge and service access clearances”](#) (p. 5-11).
- Tower light power must be installed (if required).
- Tower light alarm must be installed (if required).
- Conduits must be installed, as described in [“Conduit requirements”](#) (p. 5-7).
- AC electric service for the 9927 Distributed Base Station Outdoor Cabinet must be installed as described in [Chapter 8, “Electrical power requirements for 9927 Distributed Base Station Outdoor Cabinet”](#).
- DC electric service for the RRHs must be installed as described in [Chapter 8, “Electrical power requirements for 9927 Distributed Base Station Outdoor Cabinet”](#).
- GPS antenna runs must be installed, as described in [Chapter 10, “Site preparation requirements for 9927 Distributed Base Station Outdoor cabinet GPS antenna and microwave antenna cable”](#).
- Surge protection for antennas must be installed, as described in [Chapter 10, “Site preparation requirements for 9927 Distributed Base Station Outdoor cabinet GPS antenna and microwave antenna cable”](#).
- Grounding electrode system must be installed with sufficient pigtails, as described in [Chapter 12, “Grounding and lightning protection requirements for 9927 Distributed Base Station Outdoor Cabinet”](#).
- T1/E1 and User Alarm facilities must be installed at demarcation point as described in [Chapter 14, “Site preparation -- T1/E1 and User Alarm facilities for 9927 Distributed Base Station Outdoor Cabinet”](#).

Refer to [Appendix A, “9927 Distributed Base Station Outdoor Cabinet site preparation checklists”](#) of this document for checklists of detailed requirements.

## Conduit requirements

### Rigid conduits

Rigid conduits are used to bring various types of cables to the installation site. It is the responsibility of the customer to provide the rigid conduit and install it as part of site preparation.

The following table describes the rigid conduits that are required:

Required conduit	Purpose	Conduit specifications
AC power supply conduit	AC power cables are brought to the installation site in the AC power supply conduit.	1 1/2-inch rigid conduit must be steel
NIU conduit	T1/E1 cables and the User Alarm cable are terminated at the Network Interface Unit (NIU) and brought to the installation site in the NIU conduit.	1-inch rigid conduit must be steel

### Flexible conduit

Flexible conduit is used in installation to connect cables to the 9927 Distributed Base Station Outdoor Cabinet. It is the responsibility of the customer to provide all flexible conduit and associated fittings to the installer.

The following table describes the flexible conduits that are required:

Required conduit	Purpose	Required Supplies
AC conduit	Connects AC power supply to 9927 Distributed Base Station Outdoor Cabinet.	1 1/2-inch liquid-tight flexible metal conduit and 2 inch connectors
T1/E1 conduit	Connects T1/E1 and User Alarms to 9927 Distributed Base Station Outdoor Cabinet	1-inch liquid-tight flexible metal conduit and 2 inch connectors

## Architectural considerations

All architectural considerations shall comply with all applicable national and local codes, including the following:

- Uniform Building Code (UBC)
- Building Officials and Code Administrators (BOCA)
- Southern Uniform Building Code (SUBC)

- American Concrete Institute (ACI)
- American National Standard Institute (ANSI)
- American Standard Testing Methodology (ASTM)
- National Fire Protection Association (NFPA)

# Mounting options

## Purpose

This topic describes the mounting options for 9927 Distributed Base Station Outdoor Cabinet.

## Structural requirements

Floor loading, roof loading, and foundations must be considered during site preparation. In some cases, the cell site equipment will not rest directly on the concrete pad, floor, or rooftop. In those cases, the cell equipment will need to be supported by an intermediate structure that is fastened directly to the mounting surface. The cabinets must be supported along all four edges. The support structure must be designed in compliance with BOCA national building codes and all other applicable codes.

If the cabinets are elevated more than 152.4 mm (6 inches) above the floor surface, it is recommended that a platform be placed under the cabinets to provide a safe and convenient work surface for technicians. The customer may use a custom-designed platform and will be responsible for supplying the 12 mm (1/2 inch.) bolt size hardware. A platform bolt-down kit is available from Alcatel-Lucent.

## Concrete pad requirements

If cabinets will be installed on a concrete pad, the concrete pad must be supplied as part of site preparation and must meet the following requirements:

- Minimum pressure = 175 kg/cm<sup>2</sup> (2500 psi)
- Minimum thickness = 114 mm (4.5 inches)
- The surface of the concrete pad must comply with national and local building codes.
- The concrete pad must be able to support the maximum weight of the cabinets.
- The concrete pad must be able to allow drilling of up to 100 mm anchor holes to secure the cabinets to the pad.
- The concrete pad must be level and the total variation of the top flat surface must be  $\pm 1/4$  inch.

## Rooftop requirements

The following requirements must be met when cabinets are installed on the roof of a building:

- The building must comply with Building Officials and Code Administrators (BOCA) building codes.
- Additional support structure is required.

- The rooftop must be able to support the maximum weight of the cabinets and other auxiliary equipment.
- Adequate clearance must be provided to transport the cabinet to the roof.

### **Raised platform**

Rooftop installations must be supported by a customer-provided mounting structure or raised platform. It is the responsibility of the customer to design the rooftop platform.



# Support structure, ice bridge and service access clearances

## Purpose

This topic describes the site preparation requirements with regard to the support structure and ice bridge for the 9927 Distributed Base Station Outdoor Cabinet.

## Support structure

Support brackets and support structures must meet the requirements specified in this document and all current applicable ASTM specifications.

A customer-supplied support structure shall be used to support GPS antenna cable, hybridflex cables, microwave cables, the ice bridge, and grounding cables.

## Ice bridge

At installations where falling ice can damage cables, a customer-supplied ice bridge should be used to support the Hybridflex and microwave cable runs, and to protect them from falling ice. The height and position of the ice bridge must not interfere with access to the connections at the left or right of the 9927 Distributed Base Station cabinet.

## Service access clearances

Proper clearance must be provided around the cabinet to allow for service access.

The following minimum clearances are recommended around the 9927 Distributed BTS outdoor cabinet. The clearances are given when looking at the front of the cabinet.

Side	Clearance	Reason
Front	36 inches	Front connections, opening of door
Left	6 inches	T1, User Alarm, cable gland connections
Right	6 inches	DC Distribution/Fiber Management Box, 60ECv2
Rear	36 inches	Rear connections

# Anchoring requirements

## Overview

Cabinet anchoring must meet all requirements of the local codes, taking into consideration the seismic zone of the installation site.

## Anchor specifications

Use the following table to determine the type of anchor to use, and the hole size and depth required for the anchor hole.

Equipment	Seismic Zone	Anchor Type	Number of Anchors Required	Hole Size/Depth	Anchor set before or after unit placement?
9927 Distributed Base Station Outdoor Cabinet	0, 1, 2	1/2" drop-in anchor	4	16 mm (5/8 inch) bit /50 mm (2 inches) deep	Before
	3, 4	12 mm expansion stud anchor	4	18 mm (11/16 inch) bit /101 mm (4 inches) minimum deep <sup>1</sup>	After
60ECv2 battery cabinet	0, 1, 2	1/2 inch drop-in anchor	4	16 mm bit (5/8 inch) /50 mm (2 inches) deep	Before
	3, 4	12 mm expansion stud anchor	4	18 mm (11/16 inch) bit / minimum 101 mm (4 inches) deep <sup>1</sup>	After

### Notes:

1. If a 101 mm (4 inch) hole depth cannot be attained for a 12 mm expansion stud anchor, a 76 mm (3 inch) hole depth can be used. To make the anchor fit the shorter depth, a spacer may be removed from the anchor assembly and 25 mm (1 inch) may be cut from the end of the threaded rod prior to setting the anchor.

## Anchoring footprints

### New site anchoring footprint for 9927 Distributed Base Station Outdoor Cabinet and 60ECv2 battery cabinet

The diagram below is an anchoring footprint for the 9927 Distributed Base Station Outdoor Cabinet and 60ECv2 battery cabinet when located side by side.

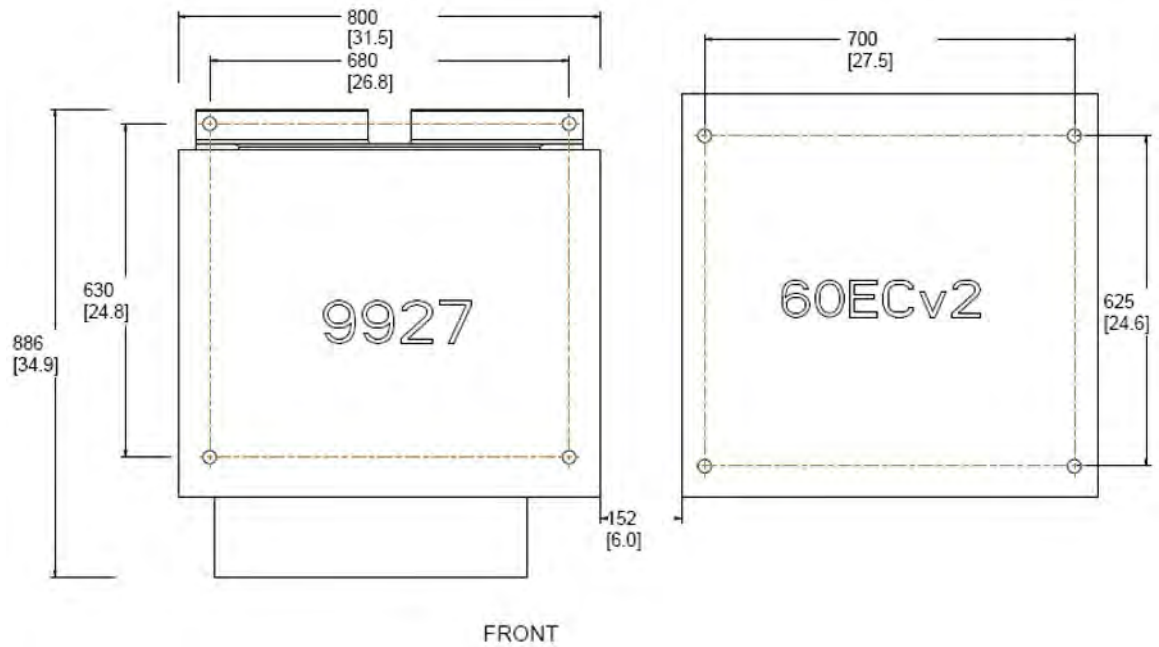

### Anchoring footprint for 60ECv2 battery cabinet

The following diagram shows the 60ECv2 battery cabinet anchoring footprint required for site preparation.

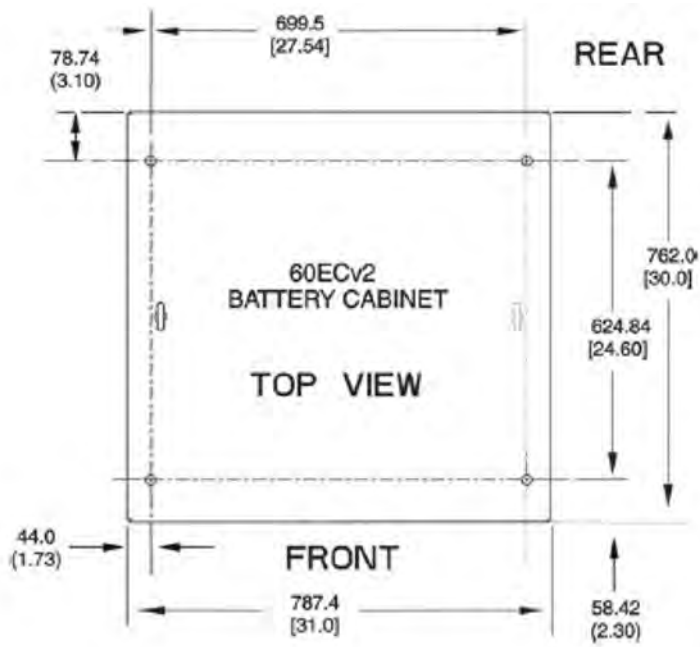

# Site preparation procedures

## Overview

### Purpose

This section contains the procedures that must be performed to prepare the site for installation of the 9927 Distributed Base Station Outdoor Cabinet.

### Contents

<a href="#">Drill anchor holes</a>	5-16
------------------------------------	------

# Drill anchor holes

## Purpose

Use this procedure to drill anchor holes in a concrete surface for the following:

- 9927 Distributed Base Station Outdoor Cabinet
- Mounting bases

## Related information

See the following topics in this document:

- [“Anchoring requirements” \(p. 5-12\)](#)
- [“Anchoring footprints” \(p. 5-13\)](#)

## Steps

Use the following procedure to drill the anchor holes in a concrete surface.

- 1 If using the optional drilling template, place the template in position.  
.....
- 2 Mark the surface for all cabinets to be installed. Refer to [“Anchoring footprints” \(p. 5-13\)](#) for cabinet anchoring dimensions.  
.....
- 3 If using the optional drilling template, remove the template.  
.....
- 4 Drill the anchor holes to the proper size and depth as specified in [“Anchoring requirements” \(p. 5-12\)](#). Refer to the following figure for the anchor hole drilling method.

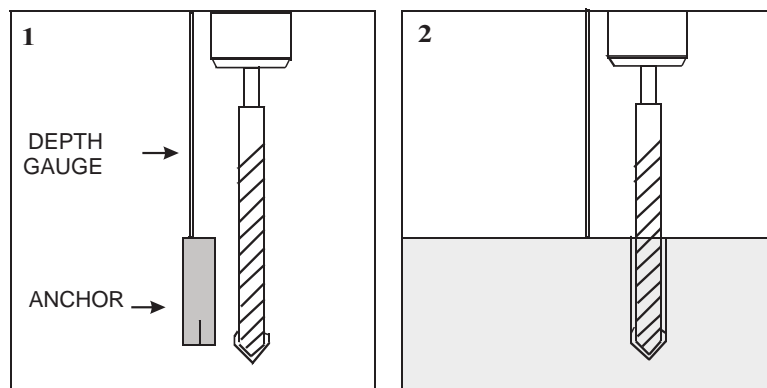

- .....  
.....
- 5 Vacuum out the holes.

- .....
- 6 Tape over the open holes to prevent debris from falling inside.

**Important!** Do not install the anchors at this time. Anchors will be installed as part of cabinet installation by equipment installers.

.....  
E N D O F S T E P S  
.....





# 6 Basic site preparation requirements and footprints for RRHs

## Overview

### Purpose

This chapter discusses how to prepare the site for installation of RRHs.

### Contents

<b>Site requirements for RRHs</b>	<b>6-2</b>
Storing RRHs in non-powered state	6-3
Environmental requirements	6-4
Site requirements for RRHs	6-5
RRH cabinet clearances	6-6
Site requirements for pole mount installations	6-8
Site requirements for wall mount installations	6-11
Site requirements for floor stand installations	6-16

---

# Site requirements for RRHs

## Overview

### Purpose

This section describes the site requirements at the installation site for RRHs

### Contents

Storing RRHs in non-powered state	6-3
Environmental requirements	6-4
Site requirements for RRHs	6-5
RRH cabinet clearances	6-6
Site requirements for pole mount installations	6-8
Site requirements for wall mount installations	6-11
Site requirements for floor stand installations	6-16

---

# Storing RRHs in non-powered state

## Purpose

**Important!** Alcatel-Lucent does not provide support for RRHs that have been left non-powered for an extended period of time and not stored in an environmentally-controlled space. The Alcatel-Lucent Design Team provides the following guidelines to minimize the build-up of moisture inside RRHs that must remain in the non-powered state for an extended period of time.

This section describes how to properly store RRHs that have been delivered to an installation site but have not been yet installed. The main concern with non-powered cabinets is condensation inside the cabinet, which can result in corrosion or electrical shorts. The location and length of storage time determine the severity of the problem. These guidelines include prevention and drying steps.

## Moisture problem prevention

To prevent moisture from collecting inside non-powered RRHs that are in storage, all openings and connectors must be tightly sealed. The units should also be covered with a waterproof tarp. The tarp should be sealed with duct tape. A desiccant packet should be placed under the tarp to absorb moisture. The amount of desiccant is related to storage time and to size of the unit. A visual check should be made to check for condensation after uncovering the tarp.

## Additional storage requirements

After performing the procedures above, ensure that the following steps are taken:

- The cabinet must be properly grounded.
- RF cables should not be connected to the RRH.
- Any connectors must be sealed with watertight plugs.
- All holes must be plugged with watertight plugs.

## Environmental requirements

### Environmental requirements for outdoor installations

In an outdoor installation temperature, humidity, and ventilation cannot be controlled.

The RRH cabinets are weather-hardened to operate under the environmental conditions listed in the table below.

Condition	Specification
Operating temperature	-40 °C to +46 °C (-40 °F to +115 °F)
Extended operating temperature	-40 °C to 50 °C (-40 °F to 122 °F)
Relative humidity	5 to 100% (non-condensing but not to exceed 0.024 kg water/kg of dry air)
Enclosure rating	Type 3R (NEMA)
	IP35 (IEC 60529)
Acoustic noise suppression	65 dBA at 25 °C (77 °F) at sea level
Operating altitude	-60.96 to 1798 m (-200 to 5,900 ft.) above sea level
Extended operating altitude	-60.96 to 3048 m (-200 to 10,000 ft.). An operating temperature de-rating of 1 °C per 1000 feet above 6000 feet is allowed
Wind driven rain	Refer to Telcordia GR-487-CORE
Dust and water ingress	Refer to Telcordia GR-487-CORE
Bullet resistance	Refer to Telcordia GR-487-CORE
Wind resistance	Refer to Telcordia GR-487-CORE
Storage requirements	Refer to Telcordia GR-63-CORE, Section 4.1.1

### RRH heat dissipation

The following table provides heat dissipation information for the various types of RRHs.

RRH type	Estimated DC heat dissipation [typical/maximum]
1900 MHz	750 watts
800 MHz	425 watts

# Site requirements for RRHs

## General requirements

The following general requirements must be met before the installation of the RRH can begin at the site:

- Adequate clearance must be provided for service access.
- Grounding electrode system must be installed.
- RF antenna runs must be installed .
- Tower light power must be installed (if required).
- Tower light alarm must be installed (if required).
- Cable supports must be installed.

Refer to [Appendix A, “9927 Distributed Base Station Outdoor Cabinet site preparation checklists”](#) of this document for checklists of detailed requirements.

## Structural requirements

Pole, wall loading, and wind must be considered during site preparation.

In some cases, cell site equipment may not be mounted directly to a wall without a plate or Unistrut. A plate or Unistrut is necessary to properly distribute the weight of the RRHs.

The support structure must be in compliance with national building and other applicable codes.

## RRH cabinet clearances

### Minimum clearances table

The following table provides the minimum wall mount clearances recommended around RRHs.

Side of RRH cabinet	Clearance in mm (inches)	Comments
Front	914 (36)	Installation access
Rear	50 (1.97)	Zero rear clearance is allowed using supplied mounting brackets.
Right	300 (11.82)	Air flow
Left	300 (11.82)	Air flow
Top	300 (11.82)	Air flow
Bottom	355 (14)	Conduit routing

### Minimum clearances for wall mounted RRHs

The following figure shows an example of typical distances between adjacent RRH cabinets. These clearances satisfy the minimum clearance requirements.

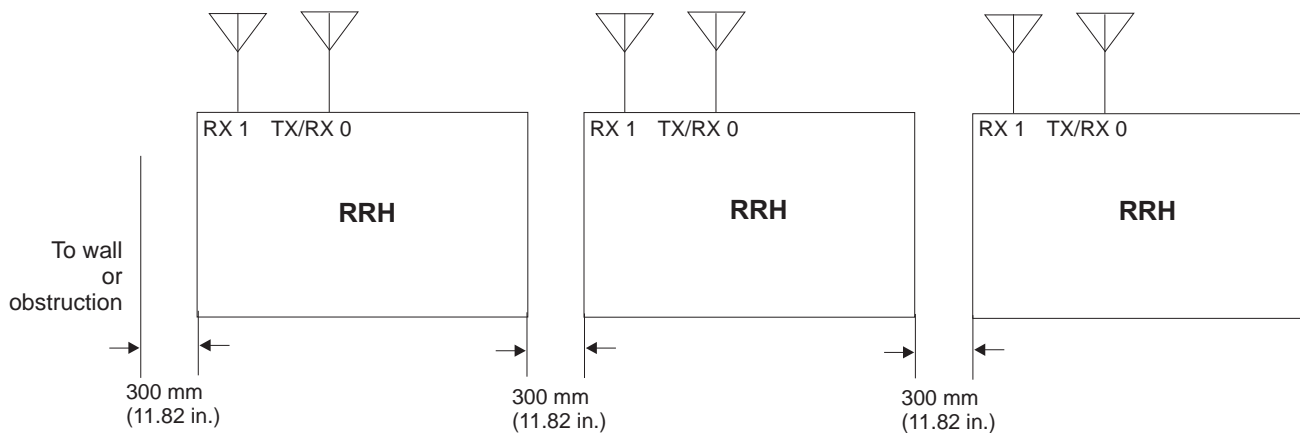

### Cables provided by Alcatel-Lucent

Hybriflex cable shall be provided by Alcatel-Lucent to connect the RRHs to the DC Distribution/Fiber Management Box. The Hybriflex cable contains fiber optic and DC power cables.

Fiber optic cable shall be provided by Alcatel-Lucent to connect the 9927 Distributed BTS outdoor cabinet to the DC Distribution/Fiber Management Box.

## Site requirements for pole mount installations

### Prepare site for pole mounting installation

The following are required to prepare a site for pole mounting installation of the cabinet.

- Install grounding system
- Install RF runs
- DC Distribution/Fiber Management Box provided by Alcatel-Lucent.
- Hybriflex cable provided by Alcatel-Lucent

### Pole mounting installation requirements

The following table provides the specifications for the low profile pole mount.

Low profile small pole mount specifications		
Standoff mm (inches)	Application	Pole diameter mm
40 (1.6)	Single cabinet installation	50 -152

The following figure shows the pole brackets needed for small diameter poles (50 mm to 152 mm).

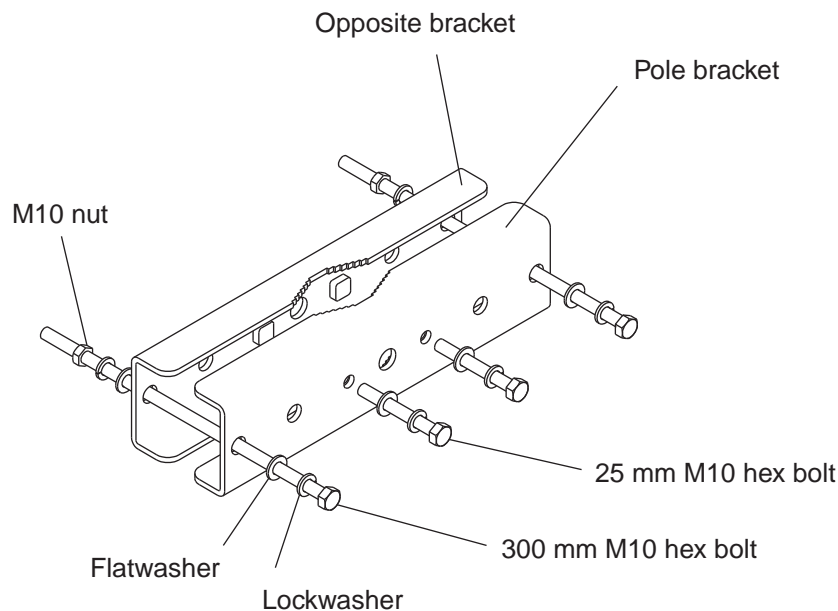



### Pole mounting example

The 800 MHz RRH and 1900 MHz, PCS, 4x40W RRH shall be mounted on a pole, as shown in the figure below.

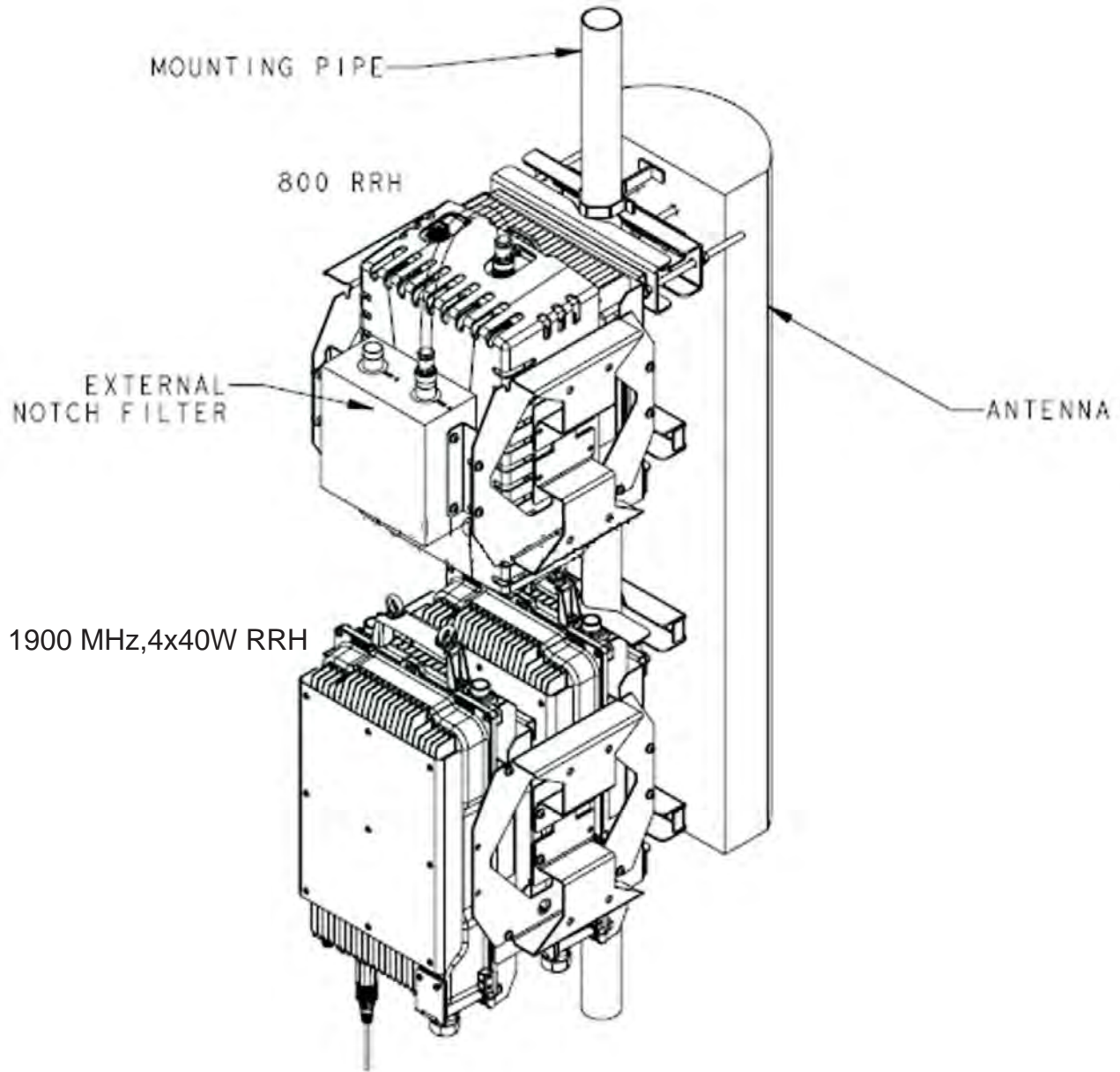

The 800 MHz RRH and 1900 MHz, PCS, 4x45W RRH shall be mounted on a pole, as shown in the figure below.

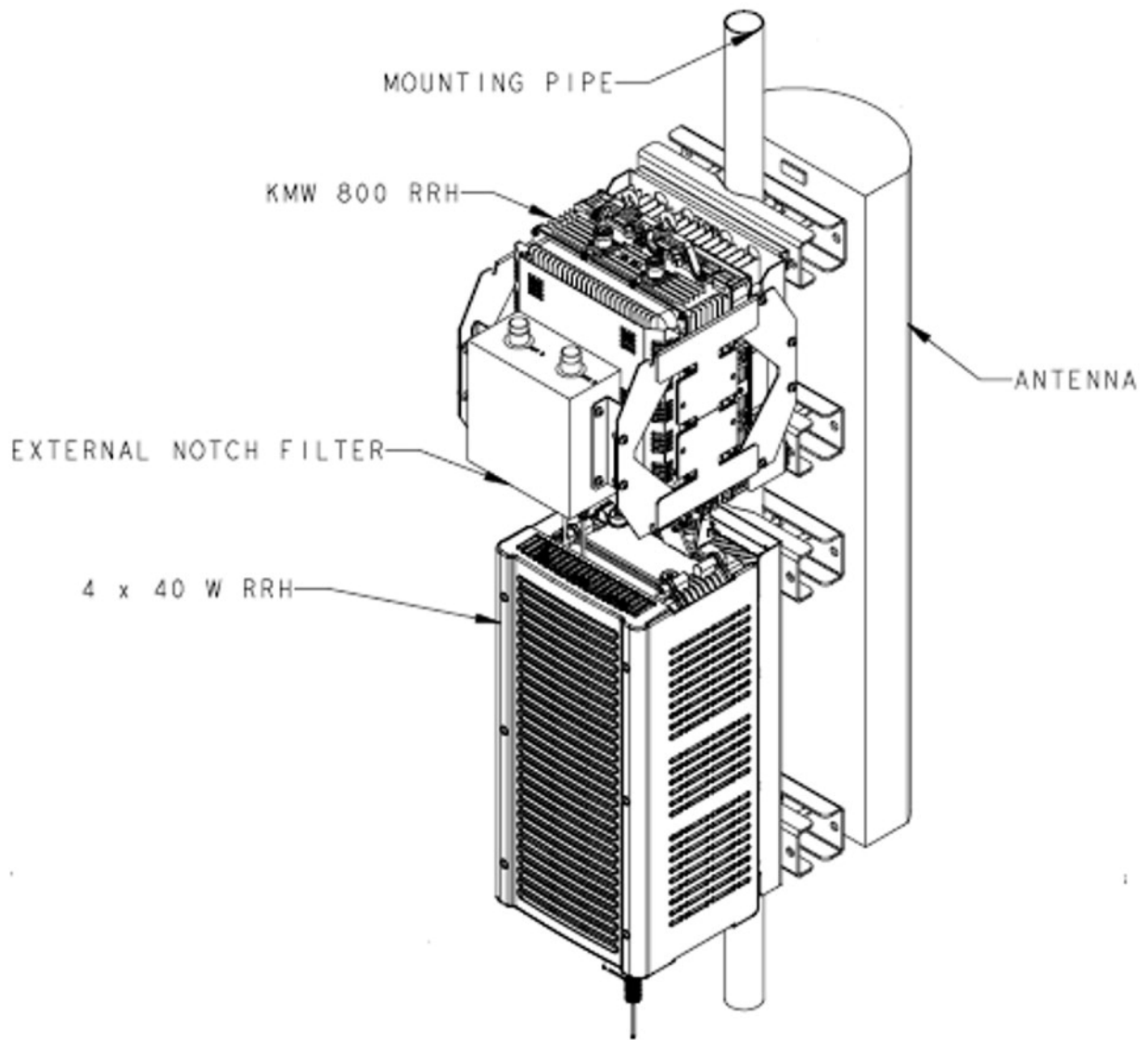

---

# Site requirements for wall mount installations

## Overview

This topic describes site requirements for installing RRHs on a wall.

## Prepare site for wall mount installation

The following are required to prepare a site for wall mount installation of the cabinet.

- Install DC power runs
- Install grounding system
- Install RF runs
- DC Distribution/Fiber Management Box provided by Alcatel-Lucent
- fiber cable

Wall mounting shall comply with the applicable architectural codes listed on listed earlier in this chapter.

Holes shall be pre-drilled with (customer supplied) anchor hardware, if mounting to a concrete wall.

Unistruts shall be in place, if required for mounting cabinet.

## Cabinet wall mounting hardware

The following is an example of customer-supplied mounting hardware that is required to mount struts to a solid concrete wall:

- 1.5 inch x 1.5 inch Unistrut® or equivalent struts (2)
- M10 (3/8 inch) x 100 mm (4inch) long Power-Stud™ (formerly called Rawl-Stud®) or equivalent anchor bolts for solid concrete walls (4)
- M10 (3/8 inch) nuts (4)
- M10 (3/8 inch) flat washers (8)
- M10 (3/8 inch) spring nuts from the same manufacturer as the struts (4)
- M10 (3/8 inch) x 80 mm (1 inch) long hex-head bolts (4)
- M10 (3/8 inch) lock washers (4).

### Wall mount hole pattern

The figure below show how holes should be drilled in the wall for mounting the 800 MHz, 2x50W RRH, 1900 MHz, 4x40W (25 MHz) RRH and the 1900 MHz, 4x45W (65 MHz) RRH.

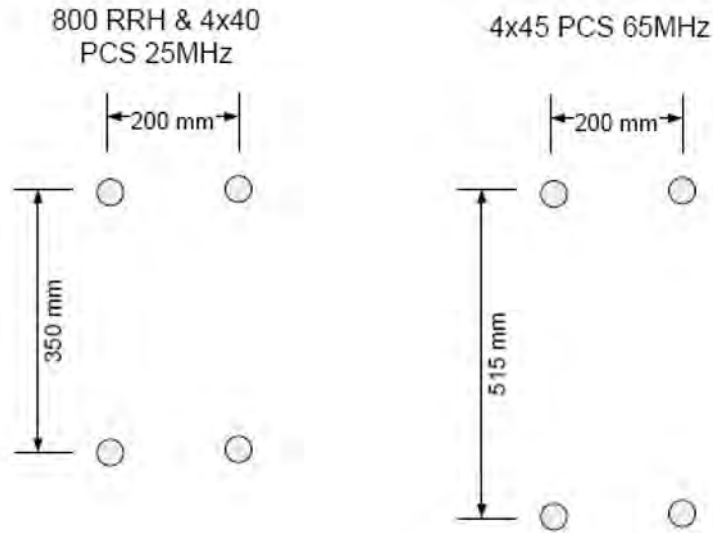

### RRH Unistrut mounting hardware

The following figure illustrates the hardware that is required to mount a Unistrut on a concrete wall and the cabinet to the Unistrut.

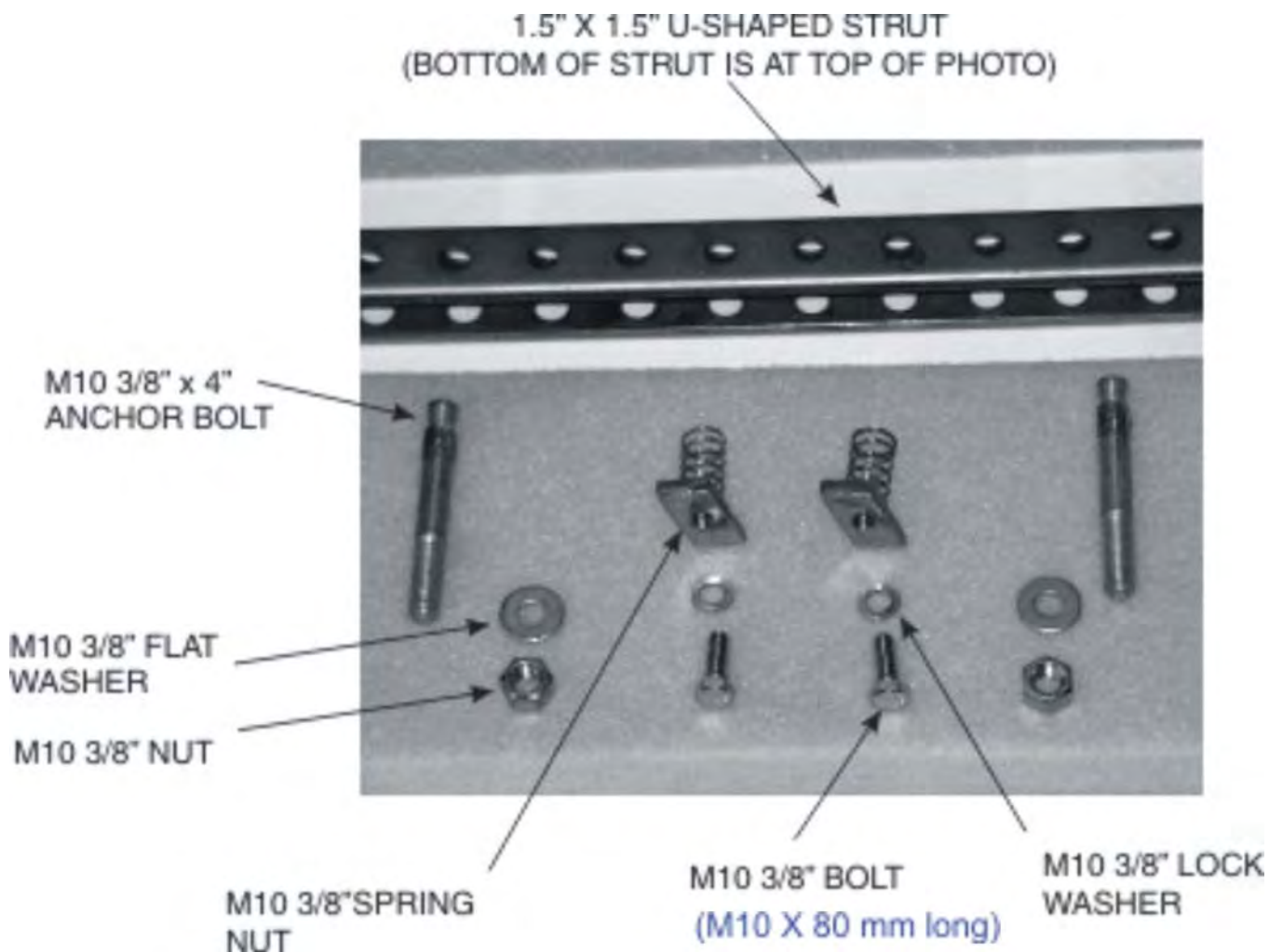

### Steps for installing Unistruts



#### CAUTION

*Damage to equipment may result.*

*Prior to drilling holes in a wall, consult with the customer as to the location of gas, water, and electrical pipes or conduits to minimize accidental hazard and equipment damage. Also consult with the building engineer as to local code requirements and wall loading information.*

Install the Unistruts as follows:

- 1 Determine the layout of the struts that will support the cabinet.
- 2 Place the top strut on the wall and make sure that the strut is level. Use the holes at the ends of the strut as a template to mark the positions of the holes to be drilled in the wall.
- 3 Place the bottom strut against the wall [350 mm (13.8 inches) for 4x40W and 800 MHz RRHs] [515 mm for 4x45W 65 MHz RRH], measured center to center, from the top strut. Use the holes in the strut as a template to mark the positions of the holes to be drilled in the wall. See the figure below.
- 4 Drill holes in the wall at the marked positions using an appropriate concrete drill bit for selected anchor.
- 5 To install the top strut, place the top strut against the wall. Drive the anchor bolts into the holes of the strut until nut and washer are flush with the strut.
- 6 Tighten the nut to proper torque requirement.
- 7 Repeat Steps 5 and 6 to install the bottom strut.

END OF STEPS

### RRH wall mount bracket assembly

The following figure shows the completed installation of a wall mount bracket on a Unistrut assembly.



---

# Site requirements for floor stand installations

## Overview

This topic describes site requirements for cabinet installation on a floor, such as the location and drilling of anchor holes for the floor stand.

## Anchor hole specifications for Floor Stand

The following table provides anchoring specifications for floor stands installed in seismic zones 0 through 4.

Seismic zone(s)	Anchor type	Number of holes	Hole size mm (inches)	Hole depth mm (inches)	Torque Nm (lbf in)
0, 1, 2	1/2inch Dia drop-in	4	16 mm (5/8 in.)	50 mm (2 in.)	24 (212)
3, 4	M12 x 125 mm	4	18 mm (11/16 in.)	100 mm (4 in.)	79 (700)



## Floor stand

The floor stand in the figure below is for installing an **800 MHz, 2x50W** or **1900 MHz, 4x40W (25 MHz)** RRH on a floor.

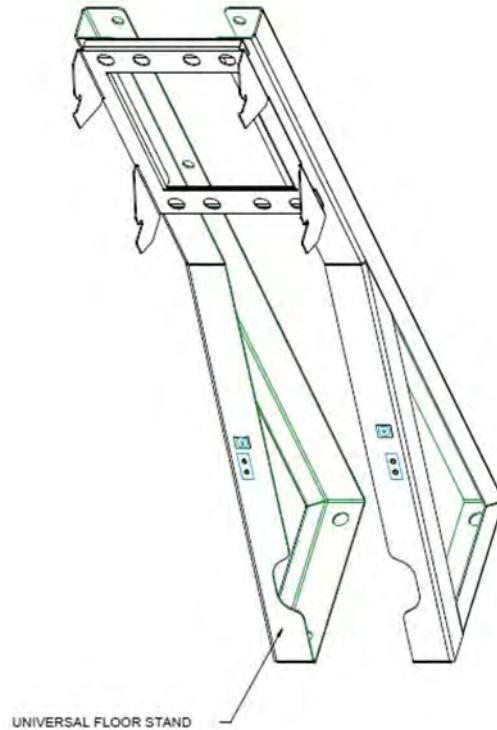

The figure below shows the anchor hole, drill pattern template for the floor stand.

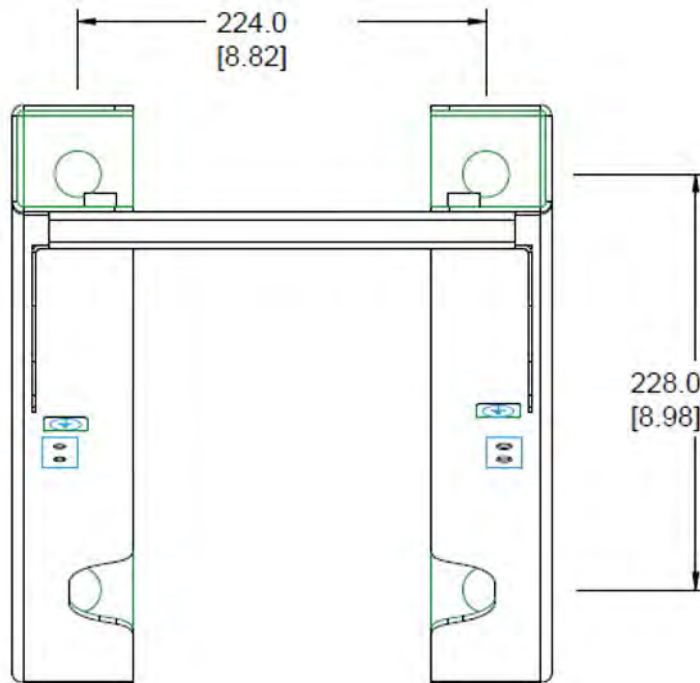

### Mark and drill the anchor holes

**Important!** The marking and drilling of the anchor holes shall be performed as part of site preparation. Anchor holes must be properly covered to prevent debris from falling inside. Before marking or drilling the anchor holes, refer to [Drill anchor holes](#) for more detail.

Proceed as follows to mark and drill the anchor holes in a concrete surface:

- 1 Measure and mark the location where the Floor Stand anchors will be installed. Refer to the above figure for anchoring footprint.
- 2 Drill the anchor holes to the proper size and depth as specified in the previous table.

**Important!** If a 100 mm (4.00 inch) hole depth cannot be attained for a 12-mm expansion stud anchor, a spacer may be removed from the anchor assembly when it is installed. The minimum depth of the hole is 76.2 mm (3.00”).

3	If	then
	floor stand <i>is not</i> available on site	Tape over the open holes to prevent debris from falling inside.  Do not install the anchors at this time. Anchors will be installed later by equipment installers.  <i>Procedure ends here.</i>
	floor stand <i>is</i> available on site	Continue with next step.

4 Center floor stand over the drilled anchor holes.

5 Set and torque the anchor bolts.

END OF STEPS



# 7 Basic site preparation requirements and footprints for DC Distribution/Fiber Management Box

---

## Overview

### Purpose

This chapter describes basic site preparation requirements for the DC Distribution/Fiber Management Box, which interfaces the RRHs with the baseband cabinet. Two 1-1/2 inch liquid-tight flexible conduits enter the DC Distribution/Fiber Management Box from the baseband cabinet. One Hybriflex cable leaves the DC Distribution/Fiber Management Box and goes to the RRHs.

### Contents

<a href="#">Cabinet clearances for DC Distribution/Fiber Management Box</a>	<a href="#">7-3</a>
<a href="#">Site requirements for wall mount installation of DC Distribution/Fiber Management Box</a>	<a href="#">7-4</a>

---

## Cabinet clearances for DC Distribution/Fiber Management Box

### Minimum clearances table

The following table provides the minimum wall mount clearances recommended around the DC Distribution/Fiber Management Box.

DC Distribution/Fiber Management Box	Clearances mm (inches)	Comments
Front	914 (36)	Installation access
Rear	50 (1.97)	Zero rear clearance is allowed using supplied mounting brackets.
Right	152.4 (6)	Installation access
Left	152.4 (6)	Installation access
Top	152.4 (6)	Installation access
Bottom	304.8 (12)	Conduit routing

---

# Site requirements for wall mount installation of DC Distribution/Fiber Management Box

## Overview

This topic describes the requirements for installing the DC Distribution/Fiber Management Box on a wall.

## Prepare site for wall mount installation

The following are required to prepare a site for wall mount installation of the DC Distribution/Fiber Management Box.

- Install grounding system
- Wall mounting

Wall mounting shall comply with the applicable architectural codes listed earlier in this chapter.

Holes shall be pre-drilled with (customer supplied) anchor hardware, if mounting to a concrete wall.

Unistrut shall be in place, if it is required for mounting cabinet.

## Cabinet wall mounting hardware

The following is a sample of customer-supplied mounting hardware that is required for mounting struts to a solid concrete wall:

- 1.5 inch x 1.5 inch Unistrut® or equivalent struts (2)
- M10 (3/8 inch) x 100 mm (4 inch) long Power-Stud™ (formerly called Rawl-Stud®) or equivalent anchor bolts for solid concrete walls (4)
- M10 (3/8 inch) nuts (4)
- M10 (3/8 inch) flat washers (8)\*
- M10 (3/8 inch) spring nuts from the same manufacturer as the struts (4)
- M10 (3/8 inch) x 25 mm (1 inch) long hex-head bolts (4)
- M10 (3/8 inch) lock washers (4).

## Location of DC Distribution/Fiber Management Box

The DC Distribution/Fiber Management Box should be installed within a 25 foot conduit distance from the 9927 Distributed BTS outdoor cabinet.



### Strut mounting hardware

The following figure illustrates the hardware that is required to mount the strut on a concrete wall and the DC Distribution/Fiber Management Box to the strut.

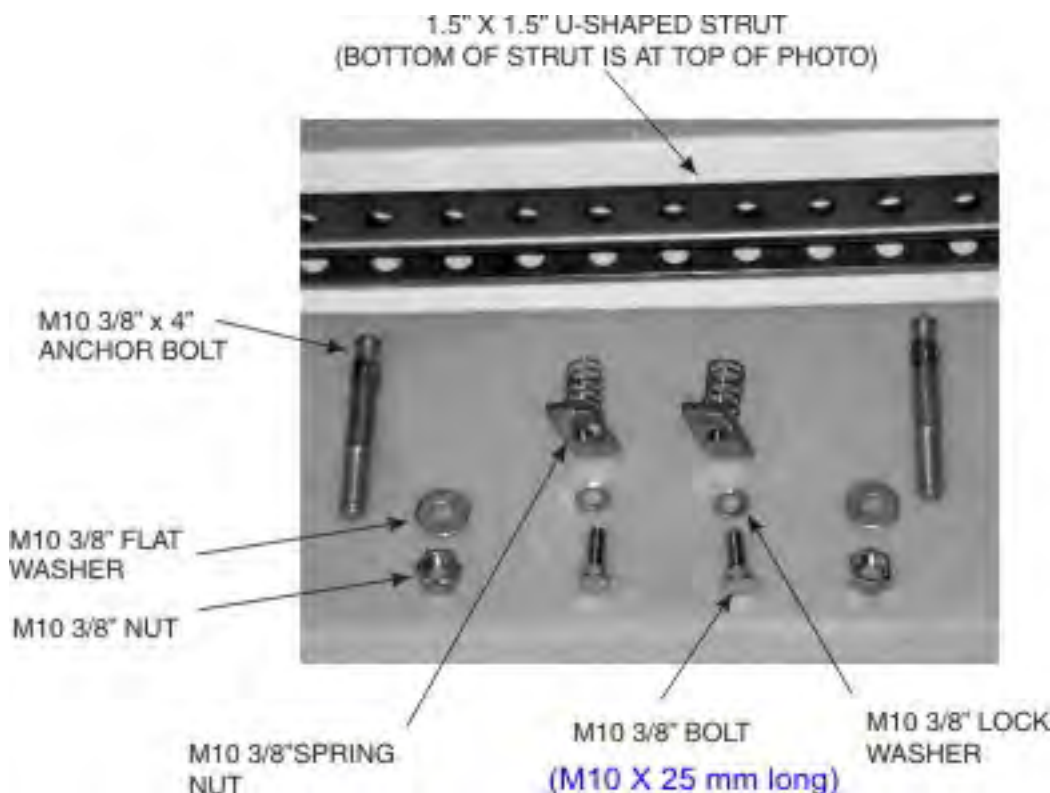

### Steps to install Unistrut



#### CAUTION

*Damage to equipment may result.*

*Prior to drilling holes in a wall, consult with the customer as to the location of gas, water, and electrical pipes or conduits to minimize accidental hazard and equipment damage. Also consult with the building engineer as to local code requirements and wall loading information.*

Proceed as follows to install the Unistrut.

- 1 Determine the layout of the struts that will support the cabinet.

- 2 Place the top strut on the wall and make sure that the strut is level. Use the holes at the ends of the strut as a template to mark the positions of the holes to be drilled in the wall.
- 3 Place the bottom strut against the wall below the top strut according to the figure below. Use the holes in the strut as a template to mark the positions of the holes to be drilled in the wall.

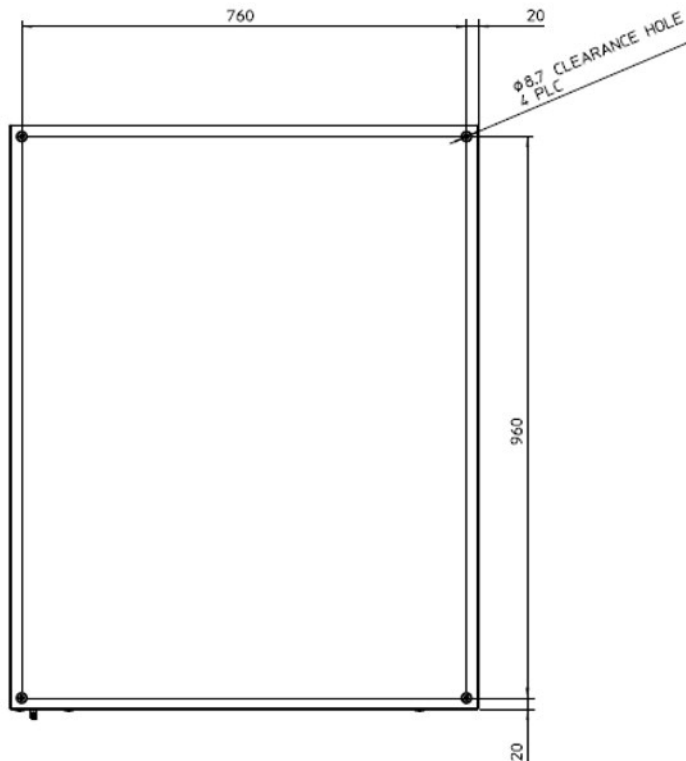

- 4 Drill holes in the wall at the marked positions using an appropriate concrete drill bit for selected anchor.
- 5 To install the top strut, place the top strut against the wall. Drive the anchor bolts into the holes of the strut until nut and washer are flush with the strut.
- 6 Tighten the nut to proper torque requirement.

- 
- 
- 7 Repeat Steps 5 and 6 to install the bottom strut.

END OF STEPS

---

### Wall mount strut assembly

The following figure shows a completed wall mount strut assembly.

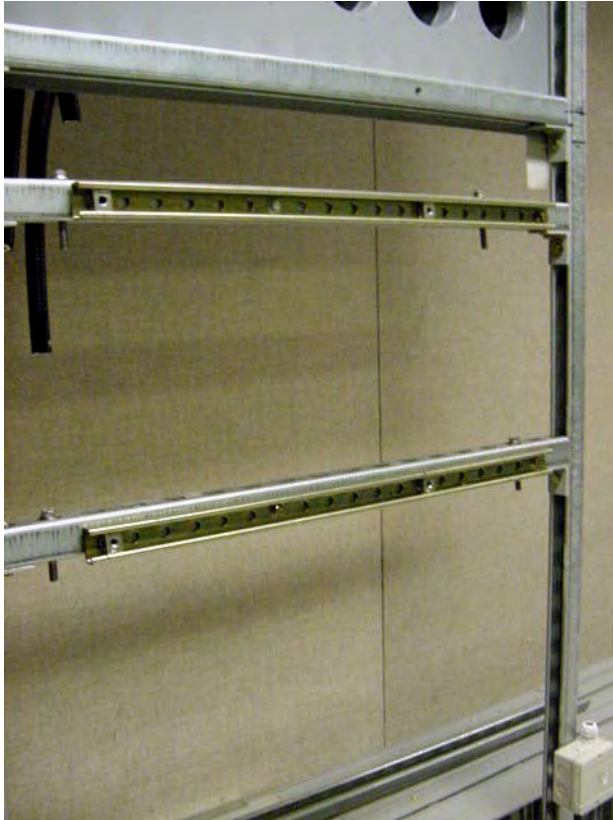

## DC Distribution/Fiber Management Box

The following figure shows the back side of the DC Distribution/Fiber Management Box. There is a hole for a bolt in each corner of the DC Distribution/Fiber Management Box. The DC Distribution/Fiber Management Box is fastened to the wall with bolts via Unistruts.



# 8 Electrical power requirements for 9927 Distributed Base Station Outdoor Cabinet

## Overview

### Purpose

This chapter provides AC electrical power requirements for the 9927 Distributed Base Station cabinets when installed at a new site.

### Contents

<b>Power overview</b>	<b>8-2</b>
Power systems	8-3
Backup power systems	8-4
Electrical service requirements for 9927 Distributed Base Station outdoor cabinet	8-5
<b>Power requirements for 9927 Distributed Base Station Outdoor Cabinet</b>	<b>8-6</b>
General requirements	8-7
AC convenience outlet, AC PDA, and AC line surge protection	8-8
AC feeder cable and service panel requirements	8-10
Power requirements for new site installation of 9927 Distributed Base Station Outdoor Cabinet	8-11
Battery Reserve Times for batteries inside 60ECv2 battery cabinet	8-12

# Power overview

## Overview

### Purpose

This section provides an overview of the power requirements for 9927 Distributed Base Station Outdoor Cabinet.

### Contents

<a href="#">Power systems</a>	8-3
<a href="#">Backup power systems</a>	8-4
<a href="#">Electrical service requirements for 9927 Distributed Base Station outdoor cabinet</a>	8-5

## Power systems

### Integrated power

The 9927 Distributed Base Station Outdoor Cabinet that is equipped with integrated power. A rectifier module converts site AC power to -48 VDC, which powers the cabinet. The rectifier module is located inside the cabinet.

---

## Backup power systems

### About backup power

The 9927 Distributed Base Station Outdoor Cabinet with integrated power requires a backup power system (a battery system) that can provide power to the cabinet in the event of a power failure.

### Battery backup options

The following table provides battery backup options for the 9927 Distributed Base Station Outdoor Cabinet. The cabinet is not equipped with internal batteries.

Battery options	Description
60ECv2 battery cabinet	Battery backup is provided by up to two 60ECv2 battery cabinets.

### Supported battery cabinets

This topic describes the 60ECv2 battery cabinet.

#### 60ECv2 battery cabinet

The 60ECv2 Battery Cabinet provides -48 VDC battery backup for the 9927 Distributed Base Station Outdoor Cabinet.

One or two 60ECv2 battery cabinets can be connected to the 9927 Distributed Base Station Outdoor Cabinet. The batteries are charged by the rectifier module inside the 9927 Distributed Base Station Outdoor Cabinet. Shelf heaters heat the batteries in cold weather. The shelf heaters are controlled by temperature sensors inside the battery cabinet.

For information on how to install the 60ECv2 battery cabinet refer to the *Installation Instructions Interface Kit for Standard Attachment of 60ECv2 Battery Cabinet to 9927 Distributed cabinets*, CC 109-779-678.



---

## Electrical service requirements for 9927 Distributed Base Station outdoor cabinet

### Electrical service requirements for the 9927 Distributed Base Station Outdoor Cabinet

The electrical service requirements for the 9927 Distributed Base Station Outdoor Cabinet are listed on the cabinet nameplate. They are as follows:

- 120/208 VAC, 120/240 VAC, 3 wire + Gnd, 80 A, 50/60 Hz

# Power requirements for 9927 Distributed Base Station Outdoor Cabinet

## Overview

### Purpose

This section describes the power requirements for the 9927 Distributed Base Station Outdoor Cabinet.

### Contents

General requirements	8-7
AC convenience outlet, AC PDA, and AC line surge protection	8-8
AC feeder cable and service panel requirements	8-10
Power requirements for new site installation of 9927 Distributed Base Station Outdoor Cabinet	8-11
Battery Reserve Times for batteries inside 60ECv2 battery cabinet	8-12

---

# General requirements

## Purpose

This section describes the AC power requirements for the Alcatel-Lucent equipment at the site.

## AC power requirements

AC power must also be provided for lighting, AC convenience outlets, and any additional AC-powered equipment that will be present at the site. The appropriate product information must be consulted to determine the total AC power required for the equipment at the site.

As part of site preparation, the site must be equipped with an appropriate AC service panel board or AC branch circuit load center for supplying power to the AC equipment at the site. All AC power wiring, distribution, and protection equipment must be installed during site preparation. The site must be ready to accept installation of the 9927 Distributed Base Station Outdoor Cabinet.



### CAUTION

#### Personnel Safety and/or Electrical Damage to Equipment

*All AC wiring and over-current protection must be installed in accordance with the National Electric Code (NFPA-70), the Canadian Electrical Code, Part 1 (CSA C22.1) or the local electrical code in effect.*

An appropriate equipment ground connection is required before commercial AC service can be connected to any equipment at the site.

## Conduit requirements

A rigid conduit for AC power supply conduit is required. It is the responsibility of the customer to provide the rigid conduit and install it as part of site preparation.

A flexible conduit for AC is also required. It is the responsibility of the customer to purchase the flexible conduits as part of site preparation, and hold them for the installer, who will install them during installation.

See [“Conduit requirements” \(p. 5-7\)](#) for specifications for the required conduits.

---

# AC convenience outlet, AC PDA, and AC line surge protection

## AC convenience outlet

Cell sites must be equipped with at least one duplex AC convenience outlet, which is needed for installation and maintenance procedures. The outlet is required to power test equipment and installation tools. The duplex outlet must be protected in accordance with national and local electrical codes. An outlet must be installed within 1.5 meters (5 feet) of the 9927 Distributed Base Station cabinets. Ground Fault Circuit Interrupters (GFCI) or Residual Current Devices (RCD), used in non-North American type installations, are recommended and must be used where required by code.

For NAR installations, this AC convenience outlet is provided in the 9927 Distributed Base Station Outdoor Cabinet. There is no need for the customer to provide an additional AC convenience outlet at the site.

## AC PDA

The AC Power Distribution Assembly (AC PDA) is inside the 9927 Distributed Base Station cabinet with integrated power. AC power to the 9927 Distributed Base Station Outdoor Cabinet must be supplied from an external AC service panel board or branch circuit load center capable of supplying a two-pole single-phase circuit to power the 9927 Distributed Base Station Outdoor Cabinet at the site.

The AC PDA is equipped with a terminal block rail populated with “strip and poke” terminals for connection of the AC input conductors and the equipment grounding conductor. The terminals are configured for either North American 120/240 V, 3-wire single-phase connections, 120/208 V, 3-wire single-phase connections, or for single-phase 230 V (line-to-neutral) connections used in other locations around the globe.

When a North American NEMA 15A-240V duplexed AC convenience outlet is equipped, a terminal is provided for the connection of the neutral conductor for this outlet.

The AC PDA in the 9927 Distributed Base Station cabinet can only be used for distributing AC power to Alcatel-Lucent equipment.

## AC line surge protection

**Important!** The 9927 Distributed Base Station Outdoor Cabinet is not equipped with AC line surge protection. AC line surge protection is required at the site's main AC panel.

A surge protection device capable of discharging the surge waveforms as defined in *IEEE C62.41 (1991), Recommended Practice on Surge Voltage in Low-Voltage AC Power Circuits, for Location Category "C3" and "High System Exposure"* must be installed in the AC panel board or load center supplying AC power to the power cabinet and/or basestand frame with integrated power. The AC panel board or load center, surge

protector, and AC wires from the service panel to the applicable cabinet, are not supplied with the power cabinet. They must be procured and installed as part of site preparation.

## AC feeder cable and service panel requirements

### AC power requirements

The 9927 Distributed Base Station cabinet requires a single-phase branch circuit from an external service panel. The service panel must be installed during site preparation.

### AC feeder cable and service panel requirements for a fully configured system (North American installation)

For a fully configured system, the AC panel must be rated at 100 A. If additional AC equipment is installed at the site, the total power consumption for all site equipment must not exceed the service rating.

The AC power feeders are class B stranded, insulated cable with THHN type insulation (T90 NYLON type insulation in Canada). The installation should not be performed in extremely cold temperatures (-15 °C / -5 °F or less).

The following table provides AC input requirements for a fully configured system with 100-A service panel (North American installation). The following table provides the recommended wire sizes.

9927 Distributed Base Station	
Component	Rating/Gauge
Circuit breaker	100 Amp, 2 pole
Wire for L1 and L2	42.4 mm <sup>2</sup> (1 AWG) <sup>1</sup>
Neutral wire	8.4 mm <sup>2</sup> (8 AWG) <sup>2</sup>
Equipment grounding conductor	8.4 mm <sup>2</sup> (8 AWG) <sup>2</sup>

#### Notes:

1. 27 mm<sup>2</sup> (3-AWG) wire may be used if the terminals on each end of the input conductors are marked "75° C." The AC input terminal block in the 9927 cabinet is rated at 75° C.
2. In Canada, 13.3 mm<sup>2</sup> (6 AWG) wire is required for telecommunications primary protector grounding. Supplementary ground conductors, sized between 13.3 mm<sup>2</sup> (6 AWG) and 33.6 mm<sup>2</sup> (2-AWG) are provided with this equipment. Refer to "[Grounding electrode system](#)" (p. 12-6).

---

# Power requirements for new site installation of 9927 Distributed Base Station Outdoor Cabinet

## How to determine power requirements for 9927 Distributed Base Station Outdoor Cabinet

The primary source for power requirements is *Engineering Rules for Factory and Field Installation Kits for 9927 Distributed Base Station*, ER\_0105\_0006.

## How to calculate power requirements for different 9927 Distributed Base Station Outdoor Cabinet configurations

The typical and maximum DC power requirement and number of rectifiers required for various 9927 Distributed Base Station Outdoor Cabinet configurations are provided in *Engineering Rules for Factory and Field Installation Kits for 9927 Distributed Base Station*, ER\_0105\_0006.

# Battery Reserve Times for batteries inside 60ECv2 battery cabinet

## Battery Reserve Times for battery strings inside 60ECv2 battery cabinet

The table below lists the Battery Reserve Times for 12IR145 battery strings inside the 60ECv2 battery cabinet. Various numbers of battery strings are connected in parallel. The provided values are for battery strings powering a 10,500 watt load. One battery string consists of two 12IR145 (145 Ah) batteries connected in series.

Battery Reserve Times for battery strings inside 60ECv2 battery cabinet powering 10,500 watt load							
(One string = Two 12IR145 (145 Ah) batteries connected in series)							
Number of battery strings connected in parallel	2	4	6	8	10	12	14
Battery Reserve Time (Hours)	0.8	1.9	3.2	4.6	6.1	7.7	9.4



# 9 Electrical power requirements for RRHs

## Overview

### Purpose

This chapter provides guidelines for running electrical power to the RRHs, when the RRHs are up to 15 m from the 9927 Distributed Base Station Outdoor Cabinet.

### Contents

<a href="#">Power requirements (general)</a>	9-2
<a href="#">Power consumption</a>	9-3
<a href="#">DC power requirements for RRHs</a>	9-4

---

## Power requirements (general)

### General requirements

This section provides the DC power requirements for the RRHs.

### Electrical power requirements for RRHs

The electrical power requirements for the RRHs, at full rated output power, are as follows.

RRH	Full rated output power at -48 VDC
1900 MHz, 4x40 W	690 Watts, 15 Amps
1900 MHz, 4x45 W	750 Watts, 17 Amps
800 MHz, 2x50 W	450 Watts, 9.0 Amps

---

## Power consumption

### General

This section provides input power requirements for RRHs. The term "typical" implies the site is operating with "busy hour" traffic and at normal room temperatures, with the batteries on float charge. End-of-life battery reserve times are typically 80% of the initial battery capacity.

The maximum levels in the table represent expected maximum load when the heater in the RRH is turned on.

### Power consumption for RRHs

The table below lists the power consumption values for the two types of RRHs.

Power Consumption for RRHs	
RRH type	Power Draw Typical (watts)
1900 MHz, PCS, 4x40W (25 MHz)	655
1900 MHz, PCS, 4x45W (65 MHz)	715
800 MHz, 2x50W	425

## DC power requirements for RRHs

### DC feeders between 9927 Distributed Base Station Outdoor Cabinet and RRHs

The DC feeder cable, from the 9927 Distributed BTS outdoor cabinet to the DC Distribution/Fiber Management Box, is routed in flexible metallic conduit.

Hybriflex cable is routed from the DC Distribution/Fiber Management Box to the RRHs. The Hybriflex cable contains four 8 AWG feeders for the RRHs.

The following table lists the circuit breaker size, wire gauge, and maximum length for copper DC feeders from the 9927 Distributed BTS outdoor cabinet to the DC Distribution/Fiber Management Box.

DC feeders from 9927 Distributed BTS outdoor cabinet to DC Distribution/Fiber Management Box			
Voltage DC, Nominal	Feeders 1 and 2		
	Circuit Breaker (AMPS)	Wire Gauge	Max. Length
-48 VDC	90	35 mm <sup>2</sup> (2 AWG)	10.7 m (35 feet)

The table below lists the wire gauges for various maximum lengths of copper DC feeder cable from the DC Distribution/Fiber Management Box to the RRHs.

DC feeders from DC Distribution/Fiber Management Box to RRHs			
Max Length	Wire Gauge (AWG)	Max Power (watts)	RRH Type
380	6	450	2x50
240	8	450	2x50
150	10	450	2x50
400	4	690	4x40
250	6	690	4x40
160	8	690	4x40
100	10	690	4x40
			4x45
			4x45
			4x45
			4x45

# 10 Site preparation requirements for 9927 Distributed Base Station Outdoor cabinet GPS antenna and microwave antenna cable

# Overview

## Purpose

This chapter discusses site preparation requirements for GPS and microwave antennas at the 9927 Distributed Base Station Outdoor Cabinet.

## Contents

<a href="#">General requirements</a>	<a href="#">10-3</a>
<a href="#">Site preparation for GPS antenna</a>	<a href="#">10-4</a>
<a href="#">Site preparation for microwave antenna cables</a>	<a href="#">10-6</a>

## General requirements

### Introduction

This section describes site preparation guidelines for the GPS antenna.

### Requirements

The following are general requirements for the GPS antenna.

- All materials for outdoor antenna cables must be rated for outdoor use.
- Alcatel-Lucent recommended antenna jumper cables, or equivalent, must be used.
- All antenna cable runs must be appropriately supported, in accordance to the connector and cable manufacturer's instructions.
- Antenna and cable sweeps must be made before start of installation.

# Site preparation for GPS antenna

## Introduction

This section describes how to perform site preparation for the GPS antenna.

## Connection overview for GPS antenna

The GPS antenna is a receive-only antenna that requires only one antenna run. The GPS antenna cable is terminated at the antenna support structure with a 7/16 DIN female connector. At the antenna it is terminated with a 7/16 DIN-male connector. A gas tube surge protector with DIN male/female connectors must also be installed. A jumper cable connects the GPS antenna surge protector to the GPS antenna connector on the 9927 Distributed Base Station Outdoor Cabinet.

GPS cable connectors and surge protectors must be rated IP-67 or better. (IP-67 rating requirement, as defined in IEC 60529, specifies total protection against dust and protection against submersion in water.)

A side view of the GPS antenna connections are shown in the following diagram.

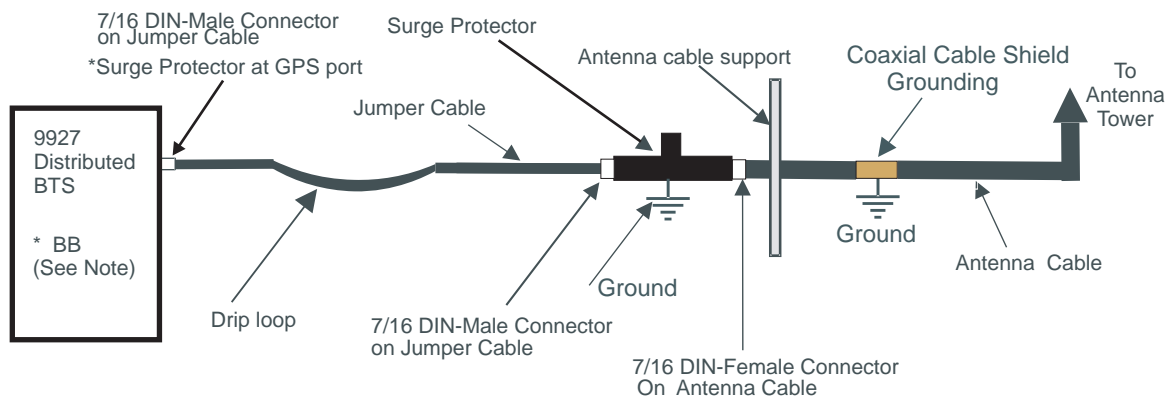

\* GPS jumper cable and field installed surge protector to 9927 Distributed BTS outdoor cabinet GPS port (1 place)

## Recommended GPS antenna cable

**Important!** The recommended cable type should be outdoor (UV) and riser (fire retardant) rated.

The following table provides information for the recommended GPS antenna cable type.

Product Specification	Manufacturer (Reference)	Cable P/N (Reference)
WP-93807 L3	OEM1	LDF4-RN-50A



---

## Surge protection for GPS antenna jumper cables

Surge protectors are required for the GPS antenna. Gas tube surge protectors are used, and must be installed as part of site preparation.

## Antenna shield grounding for GPS antenna jumper cables

The GPS antenna cable coaxial cable shield shall be bonded at least at one point close to the equipment, providing the GPS antenna is installed in the cone of protection with short (shorter than 60 foot) coaxial cable.

Grounding of the antenna cable outer shield must be performed in accordance with the ground kit manufacturer's instructions, as outlined in *Grounding and Lightning Protection Guidelines for Alcatel-Lucent Network Wireless System Cell Sites*, 401-200-115.

## GPS antenna cable lengths

The following table provides GPS antenna cable lengths information for various configurations.

Cable type	GPS antenna gain (dB)	Maximum cable length <sup>1</sup> m (feet)
LDF4	26	75 (245)

### Notes:

1. Cable lengths are based on typical applications. Cable length includes antenna and jumper cable.

## Verify GPS antenna installation

It is recommended that a Garmin 45XL (or equivalent) GPS should be used to verify GPS antenna installation and line-of-site before installing the 9927 Distributed Base Station Outdoor Cabinet.

For detailed GPS antenna installation instructions, refer to [Appendix E, "GPS antenna installation"](#).

---

# Site preparation for microwave antenna cables

## Introduction

This section discusses how to prepare the microwave antenna cables so can be connected to the 9927 Distributed Base Station Outdoor Cabinet.

## Connection overview for microwave antenna cables

The microwave cable is supplied by the customer. It will be routed and connected to the 9927 Distributed Base Station Outdoor Cabinet at a later date.

There can be up to 16 microwave cables (4 sets of 4-pack cables) entering the top-rear of the 9927 Distributed Base Station Outdoor Cabinet. In site preparation, approximately 10 feet of each microwave cable must be coiled about six feet from the top-rear of the cabinet.

Each microwave cable is terminated with an RJ-45 connector and must be connected to the appropriate injector module inside the 9927 Distributed Base Station Outdoor Cabinet.

## Label each end microwave cable

During site preparation, it is the customer's responsibility to label the end of each microwave cable so that the installer can easily identify each cable and connect it properly at installation.

Label each microwave cable at the baseband cabinet end as follows: **Microwave Ant 1**, **Microwave Ant 2**, **Microwave Ant 3**, etc.

## Recommended microwave antenna cable

**Important!** The recommended cable type is outdoor (UV) as well as riser (fire retardant) rated. The recommended cable is *Nexans SF/UTP CAT5E 4PR in&Out* .

The following table provides information for the recommended microwave antenna cable type.

Product Specification	Manufacturer (Reference)	Product Family (Reference)
Indoor/Outdoor cable suitable for: <ul style="list-style-type: none"><li>• Fast Ethernet</li><li>• Gigabit Ethernet</li><li>• Power over Ethernet</li></ul>	Nexans	LAN CAT5E 4PR In&Out IEC 61156 ISO/IEC 11801

### **Antenna shield grounding for microwave antenna jumper cables**

The microwave antenna cable shield shall be bonded every \_\_\_\_\_ feet.

Grounding of the antenna cable outer shield must be performed in accordance with the ground kit manufacturer's instructions, as outlined in *Grounding and Lightning Protection Guidelines for Alcatel-Lucent Network Wireless System Cell Sites*, 401-200-115.



# 11 RF antenna cable requirements for RRHs

## Overview

### Purpose

This chapter provides an overview of RF antenna interface requirements for RRHs.

### Contents

<a href="#">Antenna requirements</a>	11-2
<a href="#">Surge protection requirements</a>	11-3
<a href="#">General antenna cable requirements</a>	11-4

---

# Antenna requirements

## General requirements

The customer can order 1/2 inch coaxial jumper cable to interface the RRH with the antenna. It is the customer's responsibility to arrange for the construction of the RF path. This includes providing for grounding, surge protection and construction of the support structure.

## Constraints on the antenna position

In order to support location-based services, all antennas that serve a sector must be within a circle no more than 15 m in diameter.

---

## Surge protection requirements

### General requirements

The RF Filter inside the RRH is already equipped with a surge protector. RF surge protection is not required for standard star configurations (one RRH per sector).

---

# General antenna cable requirements

## General requirements

All cable runs must be supported appropriately, in accordance with connector and cable manufacturer's instructions.

The appropriate type, length, and number of antenna jumper cables should be available at the site when starting installation.

Grounding of the antenna feeder cable outer shield must be performed in accordance with the manufacturer's grounding kit instructions.

The following are general antenna requirements:

- Alcatel-Lucent recommended antenna cables should be used.
- All antenna cable runs must be appropriately supported in accordance with the connector and cable manufacturer instructions.
- All antenna connectors must be rated IP-67 or better.

**Important!** All RF connectors must be at least IP67 rated. (IP67 rating requirement, as defined by IEC 60529, calls for total protection against dust and protection against submersion in water.)

## Antenna installation

Antenna installations shall be performed in accordance with all applicable manufacturer's recommendations, and national laws and regulations.

To ensure correct antenna installation, all necessary calculations and/or field measurements shall be evaluated for compliance with applicable national laws or regulations regarding exposure to electromagnetic fields. The antenna manufacturer or supplier shall deliver all technical data necessary to perform this compliance evaluation (e.g., antenna gain pattern, antenna dimensions, etc.). Information about methodology and results of compliance evaluation shall be available for inspection by officials of governing authorities.

## Antenna cable grounding

Grounding of the antenna cable outer shield must be performed in accordance with the ground kit manufacturer's instructions, as outlined in *Grounding and Lightning Protection Guidelines for Wireless System Cell Sites*, 401-200-115.



The following figure shows a typical method for connecting an antenna cable.

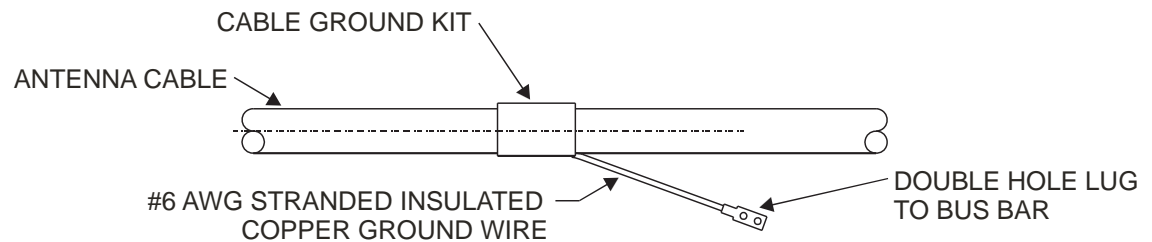

### RF antenna connections

The RRH accepts two RF antenna cables on top of the unit.

The connectors are 7/16 DIN. One 7/16 DIN connector is for Tx/Rx, the other is Rx-only.

An external RF surge protector is not required.

### RF antenna cable requirements

The RRH can support up to two RF antennas per one-sector configuration with transmit/receive diversity. The RF antenna cable must satisfy the following requirements:

- Impedance: 50 ohms
- Attenuation: < 3 dB
- 

Antenna jumper cable at the baseband cabinet end must be equipped with a 7-16 DIN center pin straight male connector.

- Surge protection (not required for outdoor)
- properly grounded.



# 12 Grounding and lightning protection requirements for 9927 Distributed Base Station Outdoor Cabinet

## Overview

### Purpose

This chapter provides information on grounding and lightning protection requirements for a 9927 Distributed Base Station Outdoor Cabinet site.

### Contents

<a href="#">Grounding requirements</a>	12-2
<a href="#">Surge protection requirements</a>	12-3
<a href="#">Grounding electrode system</a>	12-6

---

# Grounding requirements

## General requirements

The 9927 Distributed Base Station Outdoor Cabinet must be grounded by means of an integrated (multipoint) grounding system. The equipment is susceptible to lightning surges because it is associated with towers and antennas. It is therefore imperative that the cell site be properly grounded and that a low impedance path to earth be provided. The grounding conductors must be as straight and short as possible. No sharp bends or loops are permitted for grounding conductors.

## NOTICE

### Equipment Warranty

*The equipment warranty can be voided if the guidelines in the National Electrical Code (NFPA 70), the Canadian Electrical Code, Part 1 (CSA C22.1), or the local code in effect, as well as the Standard for Installation of Lightning Protection Systems (NFPA 780, latest edition), and Grounding and Lightning Protection Guidelines for Alcatel-Lucent Network Wireless System Cell Sites, 401-200-115 are not followed.*

---

## Surge protection requirements

### General surge protection requirements

Commercial AC power and T1/E1 facilities are susceptible to lightning surges and must be properly protected. An appropriate surge protection device must be installed at the service entry point and be connected directly to the grounding electrode system.

The GPS antenna coaxial cables are also susceptible to lightning surges and must be protected.

As part of site preparation, a surge protection device must be installed between each antenna coaxial cable and jumper cable, approximately 1 meter (3 ft.) away from the equipment. They can be obtained from Alcatel-Lucent (KS24577, L-3A for GPS and KS24577, L-4A for RF), or an Alcatel-Lucent-approved equivalent can be used.

The surge protectors must be bonded to a nearby ground bus bar that is connected directly to the grounding electrode system at two points.

## Diagram of a typical surge protector installation

The following diagram shows a typical surge protector installation.

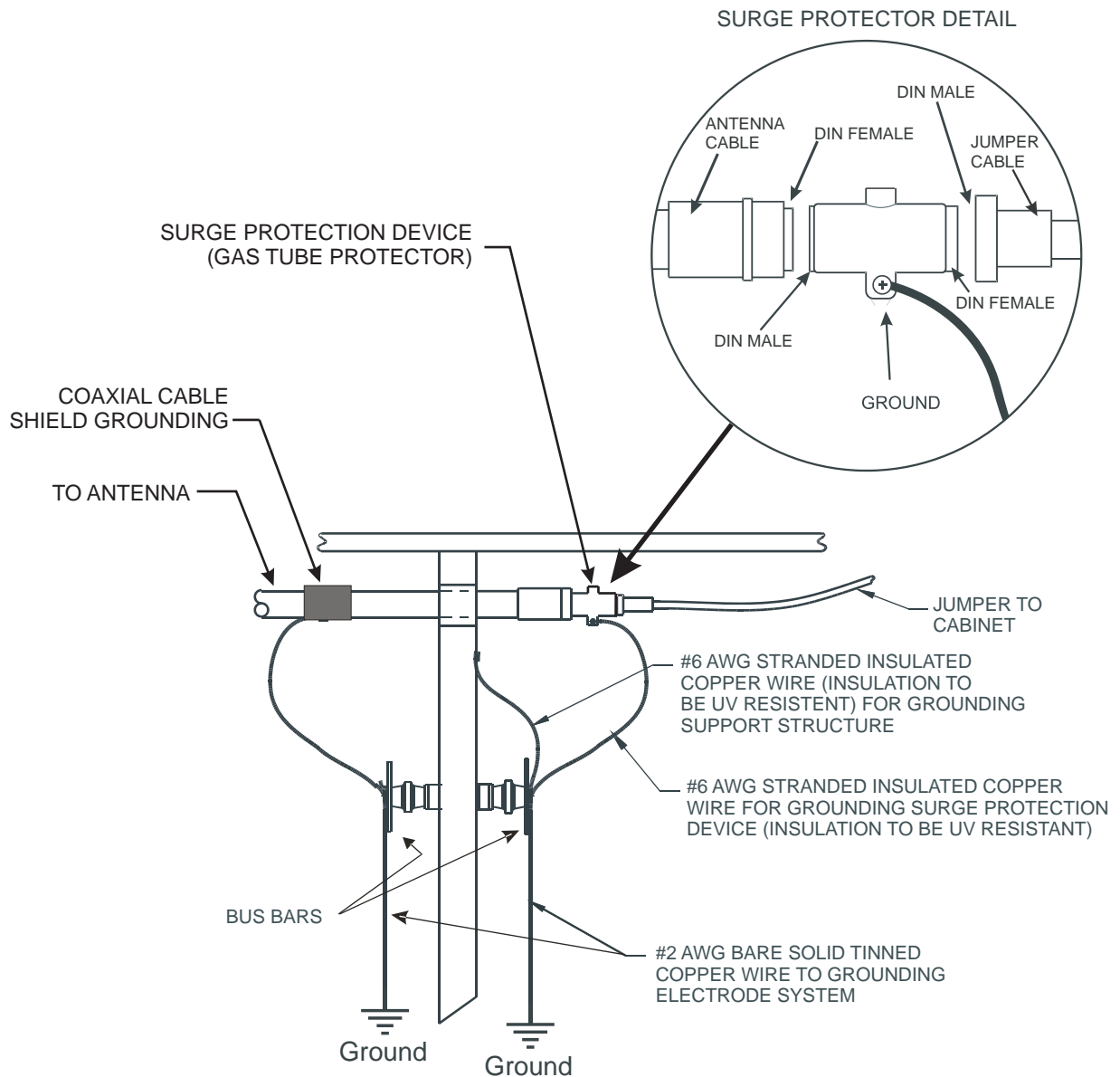

## Antenna cable shield grounding for GPS antenna

The tower or metallic support for the antenna must also be bonded to the grounding electrode system.

The GPS antenna coaxial cable shield shall also be bonded at one point (minimum), near the equipment, before entering a building, provided the GPS antenna is installed in Zone of protection with short (60 feet / 18 meters or less) coaxial cable.

**Important!** If the coaxial run along the tower is more than 60 feet / 18 meters, then the coaxial cable shields to be grounded at multiple points near the antenna and equipment at 100 foot (30 meter) intervals.

The following diagram shows a typical method for grounding an antenna cable outer shield.

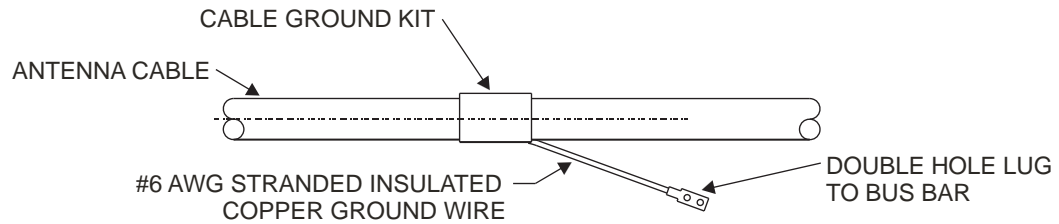

---

## Grounding electrode system

### Grounding electrode system requirements

9927 Distributed Base Station Outdoor Cabinet sites must be equipped with a grounding electrode system (that is, buried ring ground, copper clad rod, electrolytic rods, metallic water pipe, etc.). The cell site grounding, including all cabinets and antenna cable shields, must be bonded to the grounding electrode system.

The grounding electrode system shall be installed as part of site preparation with a sufficient number of pigtailed. Electrically conductive materials in the vicinity that are likely to become energized must be connected together and to the grounding electrode system in a manner that establishes an effective ground-fault current path.

Buried ground conductors must be, at a minimum, 33.6 mm<sup>2</sup> (2 AWG) bare, solid, tinned copper wire. Exterior ground conductors must be, at a minimum, 33.6 mm<sup>2</sup> (2 AWG) either solid, bare, tinned copper or stranded, insulated (outdoor insulation to be sunlight-resistant) copper cable.

### Exothermic weld

Exothermic weld is recommended for grounding connections where practical. All below-grade connections must be exothermically welded. Compression type, two-hole (0.75-inch center) lugs or double crimp “C” taps are acceptable for above-ground connections. The contact area where connections are made shall be prepared to a bare bright finish, and be coated with an anti-oxidation material before connections are made.

**Important!** All grounding system material (cable, connectors, buses, etc.) must be of high quality materials that resist deterioration and require little or no maintenance.



### Typical grounding configuration (concrete pad)

The following diagram shows the typical grounding configuration for a 9927 Distributed Base Station Outdoor Cabinet site on a concrete pad.

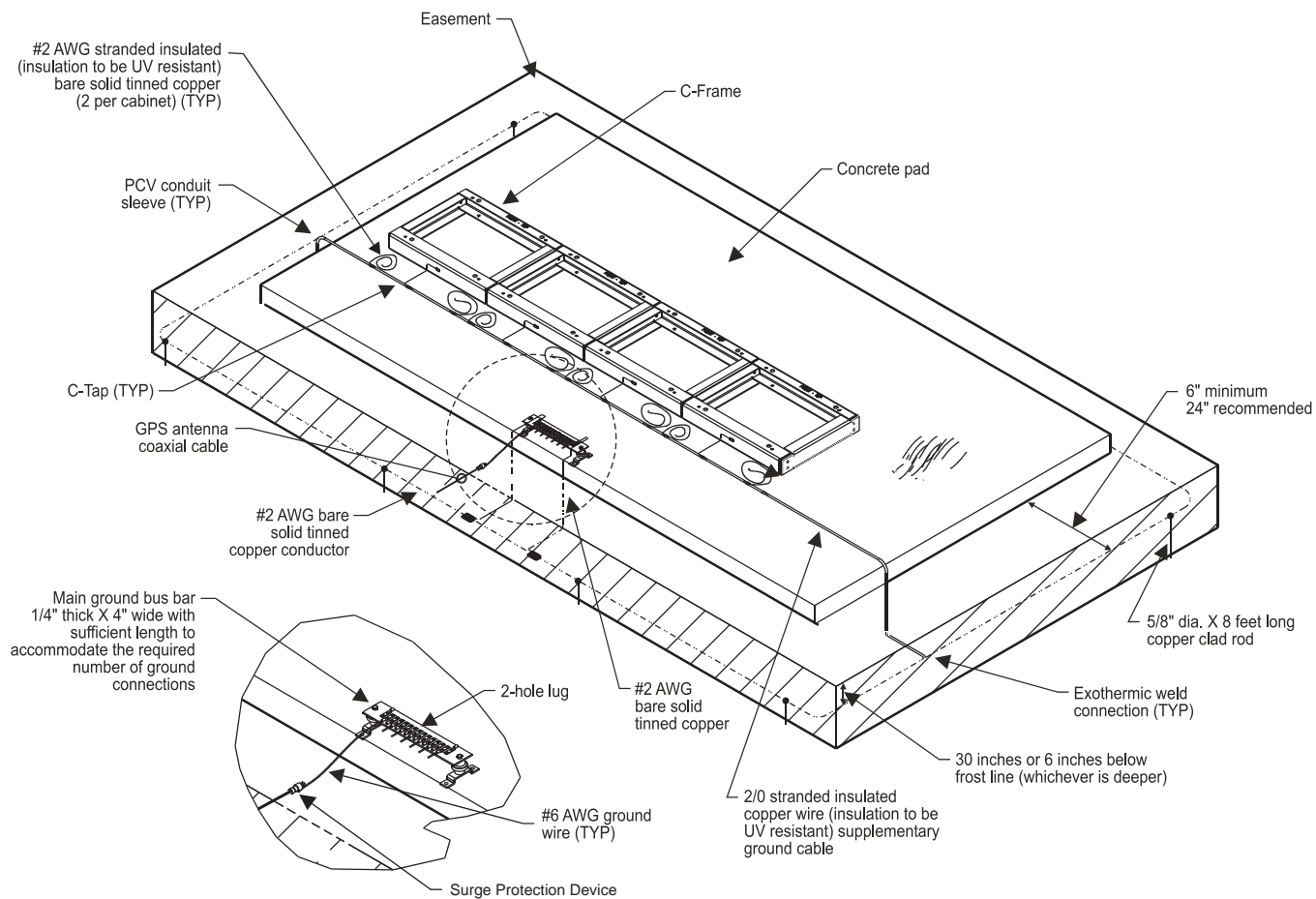

### Typical grounding configuration (rooftop)

The following diagram shows the typical grounding configuration for a 9927 Distributed Base Station Outdoor Cabinet site on a rooftop.

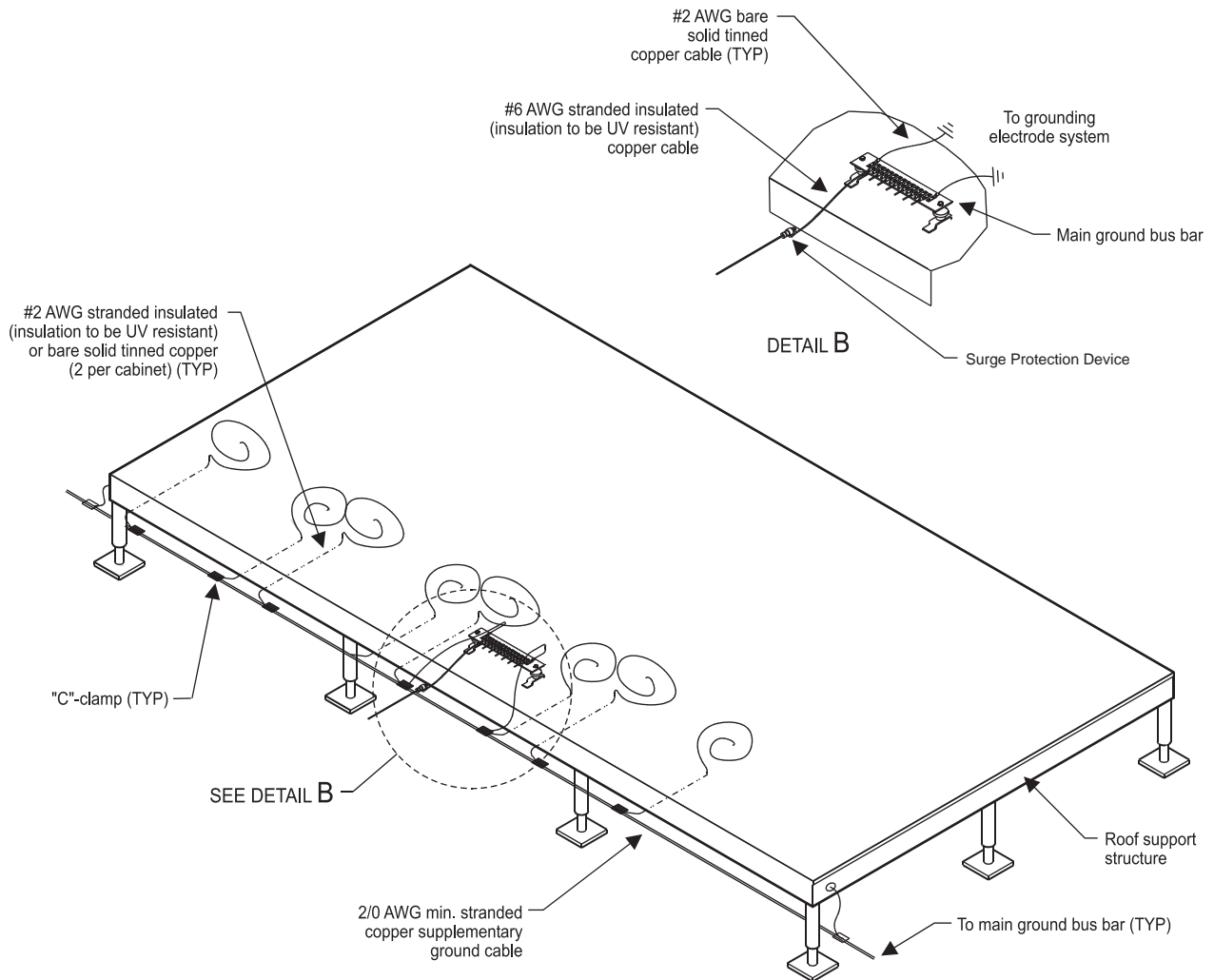

# 13 Grounding and lightning protection requirements for RRHs

## Overview

### Purpose

This chapter discusses grounding and lightning protection requirements for the RRHs.

### Contents

<a href="#">Grounding and surge protection requirements</a>	13-2
<a href="#">Grounding examples - Remote Radio Head</a>	13-3

---

# Grounding and surge protection requirements

## Surge protection in RRHs

The RRHs are equipped with internal surge protectors. No external surge protectors are required.

---

## Grounding examples - Remote Radio Head

### Wall mount grounding

Each RRH cabinet must be grounded.

The RRH cabinet must be grounded as follows:

1. At the top of cabinet
2. At the right side of cabinet.

The figure shows how 6 AWG ground cable can be routed from a wall mounted RRH to the system ground.

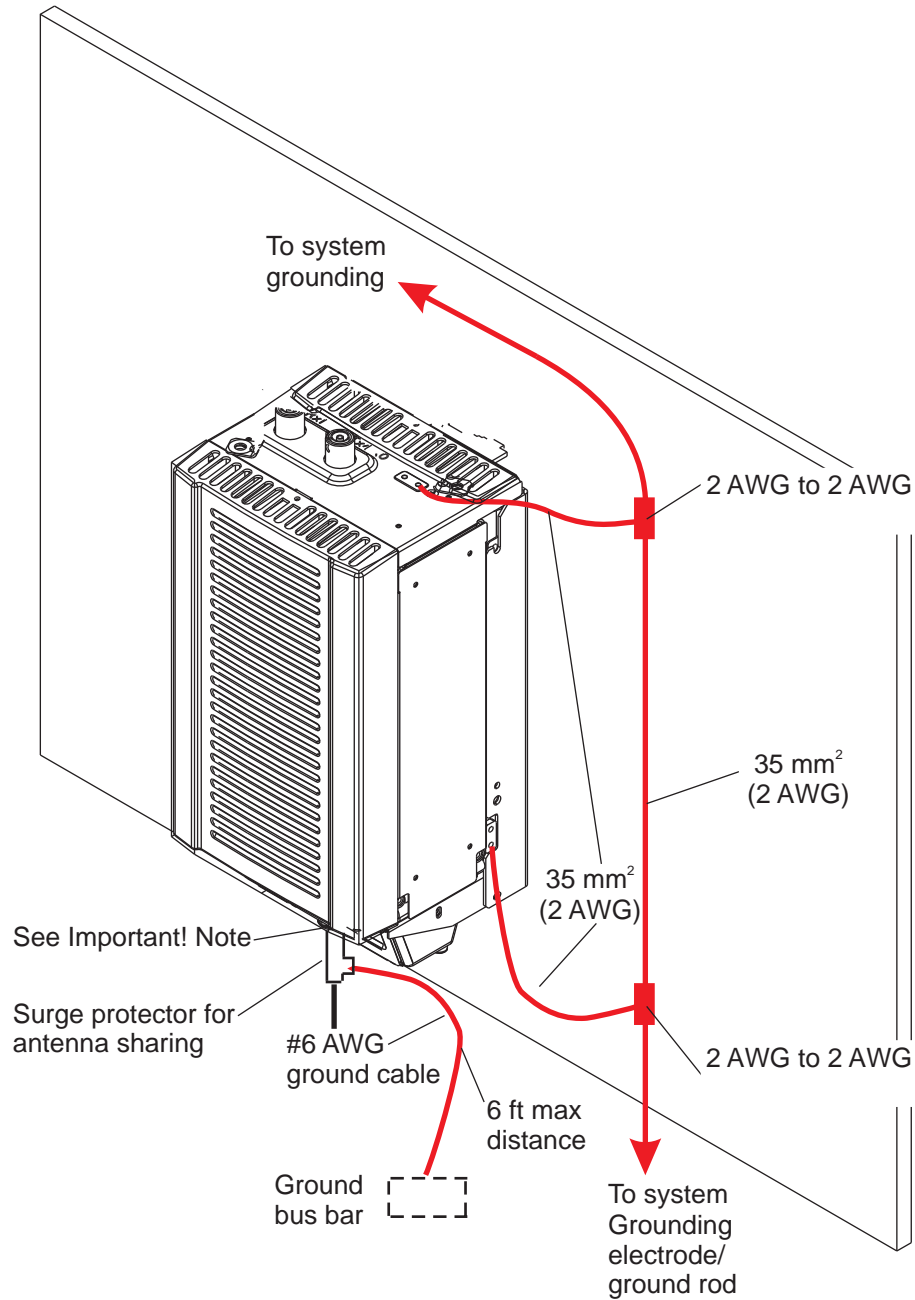

**Important!** In order to connect an antenna sharing surge protector to ground, a grounding bus bar must be installed within 6 feet of RRHs. This applies to antenna sharing/daisy chain installations (two RRHs per sector).

### Pole mount grounding

Each RRH cabinet must be grounded.

Each RRH cabinet must be grounded as follows:

- At the top of the cabinet
- At the left or right side of the cabinet.

The figure below shows how 2 AWG ground cable can be routed, along the pole, from the RRH to the ground rod.

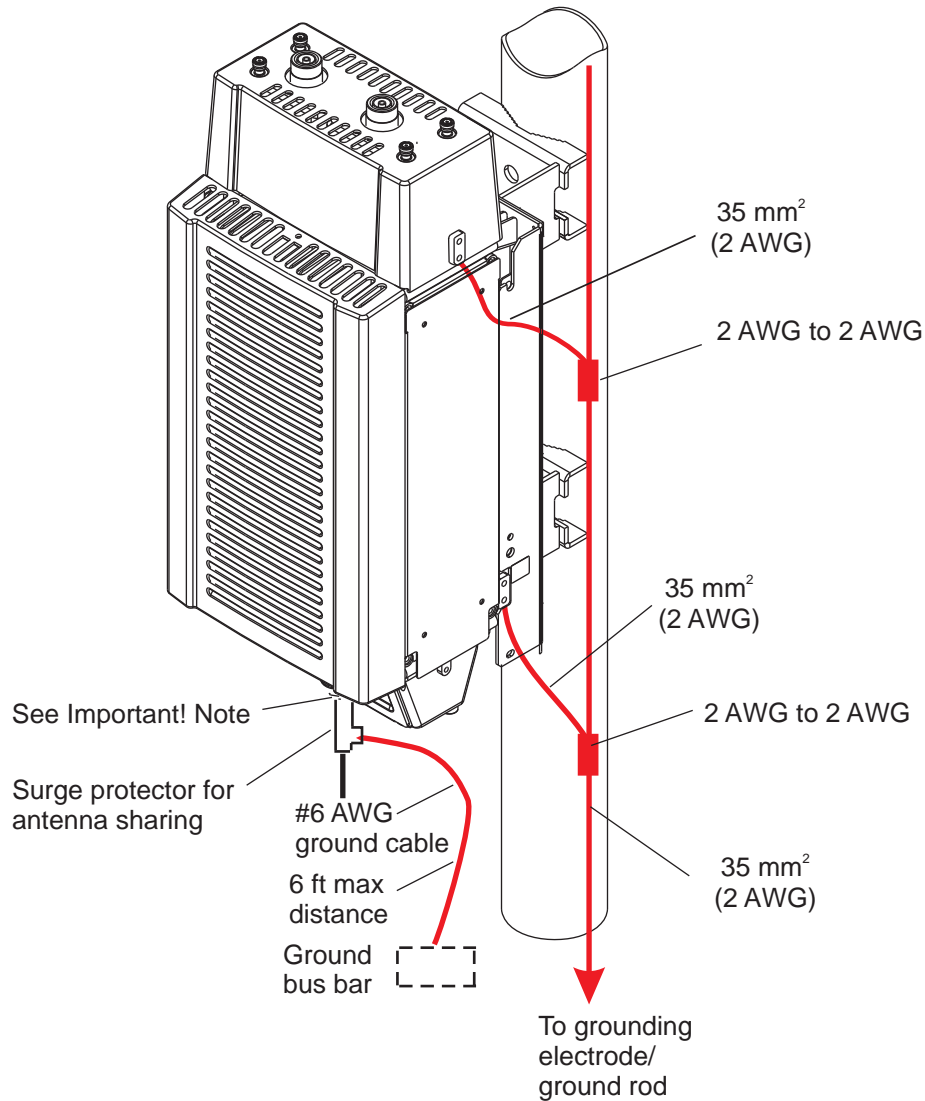

**Important!** For antenna sharing/daisy chain installations (two RRHs per sector), a grounding bus bar must be installed within 6 feet of the RRHs, to ground the antenna sharing surge protector.





# 14 Site preparation -- T1/E1 and User Alarm facilities for 9927 Distributed Base Station Outdoor Cabinet

## Overview

### Purpose

This chapter describes the site preparation requirements related to T1/E1 and User Alarm facilities for 9927 Distributed Base Station Outdoor Cabinet.

### Contents

Balun Block requirements	14-2
Site preparation for T1/E1 and User Alarm cables	14-3
Specify assignments for T1/E1 lines	14-6
Site preparation for User Alarm cables	14-9

## Balun Block requirements

### Overview

The customer is responsible to convert the 75 ohm unbalanced coaxial cable to 120 ohm balanced twisted pairs. The conversion of the coaxial cable to twisted pairs may be accomplished with Alcatel-Lucent balun or equivalent.

**Important!** The customer shall provide primary protection and the appropriate hardware to mount and ground the Balun Block.

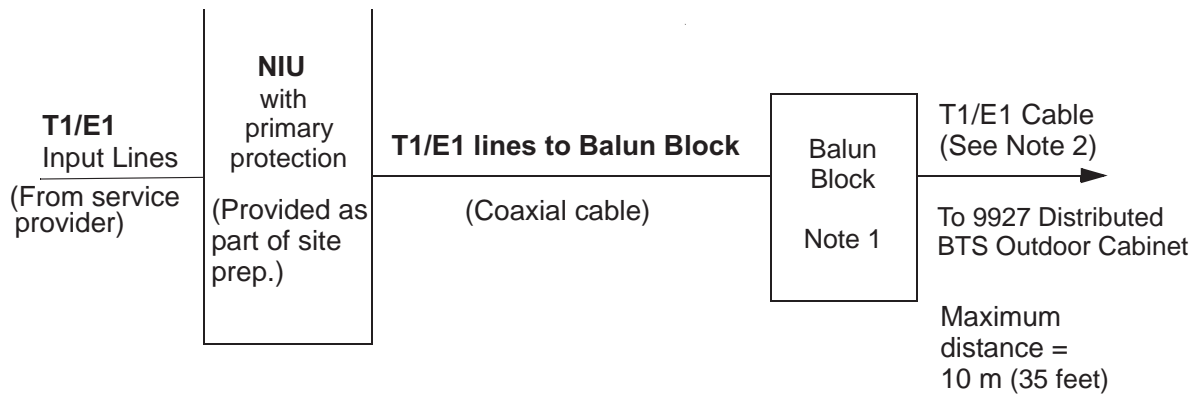

NOTE 1: The Balun Block must be located within a 10 m (35 foot) cable length distance from the radio cabinet.

NOTE 2: RJ-45 connectors must be installed on T1/E1 cables before T1/E1 cables can be connected to a Balun Block. There can be up to two T1/E1 cables. Each T1/E1 cable contains 24 twisted-wire pairs. Three branch cables can go to a Balun Block. Each branch cable contains 8 twisted-wire pairs. Each balun block accepts 8 twisted-wire pairs or 4 T1 lines. Each T1 line contains 2 twisted-wire pairs. Therefore, a cable with 24 twisted-wire pairs contains 12 T1 lines and requires 3 Balun Blocks.

A second 24 twisted-wire pair cable is required for a 9927 Distributed BTS Outdoor Cabinet populated with URC-IIIs (which allow up to 20 lines). In this case, 16 of the 24 twisted-wire pairs would be used. Refer to Balun Blocks #4 and #5 in the following table.

### Balun Block connections

**Important!** The Balun Block must be installed within 10 m (35 feet) of the 9927 cabinet. The T1/E1 cable will be connected directly to the Balun Block. Four RJ-45 loose connectors will be provided with each Balun Block. The RJ-45 connectors will be connected to T1/E1 cables during installation of the 9927 Distributed Base Station Outdoor cabinet. An RJ-45 connector crimping tool is needed to connect RJ-45 connectors to T1/E1 cable twisted-wire pairs. The part number for the RJ-45 connector crimping tool is R-5520.

## Site preparation for T1/E1 and User Alarm cables

### Purpose

This section describes how to perform site preparation for T1/E1 and User Alarm cables.

T1/E1 and User Alarm cables are both twisted-pair cables that are connected on one side to the Network Interface Unit (NIU) and on the other side to the 9927 Distributed Base Station Outdoor Cabinet. The site preparation for T1/E1 and User Alarm cables is performed at the same time.

### Connection overview for T1/E1 and User Alarm cables

The following diagram shows the installation of the twisted-pair cable from the NIU to the EFIM inside the 9927 Distributed Base Station Outdoor Cabinet.

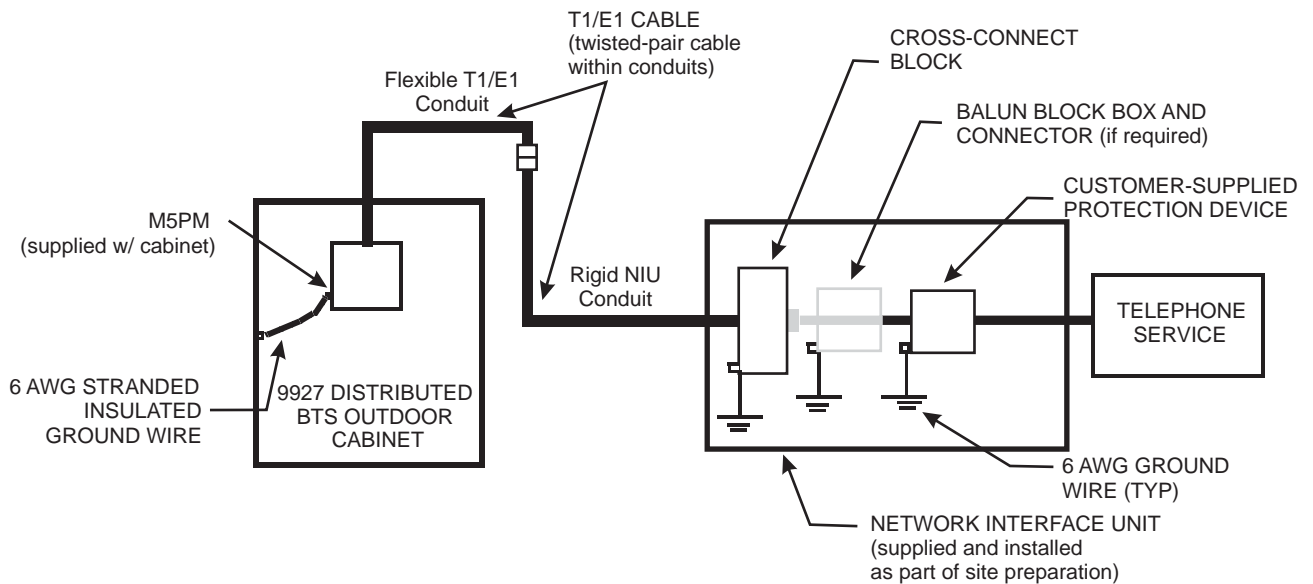

### Number of T1/E1 cables

The number of T1/E1 cables, which can be connected to a 9927 Distributed Base Station cabinet varies depending upon the number of SEC-B installed in the cabinet. Four T1/E1 lines go to each SEC-B.

### Number of User Alarm cables

The 9927 Distributed BTS is equipped with an M5PM alarm module, which can accept up to 32 User Alarms. One alarm cable supports 16 alarms.

---

## Connect T1/E1 cables and User Alarm cables to NIU

The T1/E1 and User Alarm facilities must be in place prior to installation of the 9927 Distributed Base Station Outdoor Cabinet. The service provider usually supplies a carbon or gas tube protector for the T1/E1 facility. The 9927 Distributed Base Station Outdoor Cabinet is already equipped with Listed primary surge protection. If required, a Balun Block must also be installed to balance the impedance of the coaxial cable with the impedance of the twisted-wire pairs at the Network Interface Unit (NIU).

The required twisted-pair cable must be supplied and connected to the T1/E1 facility at the NIU, as part of site preparation. Sufficient cable length must be coiled to allow for future connection to the Enhanced Facility Interface Module (EFIM) inside the 9927 Distributed Base Station Outdoor Cabinet. The appropriate number of T1/E1 cables must be available at the site prior to installation.

**Important!** In the United States, refer to Article 800 of the National Electrical Code, NFPA 70, for selection and installation of the primary protector. In Canada, refer to Section 60 of the Canadian Electrical Code, Part 1, CSA C22.1 for selection and installation of the primary protector.

For international applications, refer to ITU K.11, “Principles of Protection Against Over-voltages and Over-currents.”

**Important!** Unused or spare T1/E1 cables at the NIU *must not* be looped back towards the 9927 Distributed Base Station Outdoor Cabinet while the cabinet is in operation.

The twisted-pair cable must be installed in a dry location with minimal humidity. The installation must not be performed in extremely cold temperatures [-15 °C (5 °F) or less] (see “[Minimum installation temperatures](#)” (p. 5-4)).

It is recommended that the T1/E1 cable shield be bonded at the end that connects to the NIU.

## Install rigid NIU conduit and flexible T1/E1 conduit

This topic describes the conduits required for T1/E1 and User Alarm cables. T1/E1 and User Alarm cables are routed through the conduits that are already in place for the 9927 Distributed Base Station cabinet.

Rigid NIU conduit is required to bring T1/E1 and User Alarm cables to the site. It is the customer's responsibility to provide rigid conduit and all required connectors and fittings. The customer must also install these in site preparation.

---

The recommendations for NIU conduit are as follows:

- The rigid NIU conduit must be installed from the NIU to the 9927 Distributed Base Station Outdoor Cabinet.
- Use PVC conduit instead of rigid NIU conduit if it is to be buried. Use metal conduit if it is to be exposed. The NIU end of the conduit must be bonded if it is metallic.

Flexible T1/E1 conduit is also required. It is the responsibility of the customer to provide flexible conduit and all required connectors and fittings, and to hold them for the installer.

See [“Conduit requirements” \(p. 5-7\)](#) for specifications for the required conduits.

### **Route the T1/E1 and User Alarm cables through the conduits**

After the T1/E1 and User Alarm cables have been connected to the NIU, and the conduits have been installed, the T1/E1 and User Alarm cables must be routed through the NIU conduit, and coiled approximately 6 meters (20 ft.) at the end of the conduit.

To prevent damage to the twisted-pair cable inside the conduit, the conduit end must be properly protected against the environment, rodents, and other interferences. This can be done by stuffing the twisted-pair cable into the conduit, and capping the end of the conduit.

## Specify assignments for T1/E1 lines

### Purpose

This section describes how to determine the T1/E1 line assignments for T1/E1 cables, and record them in a table that will be used during installation.

### T1/E1 line assignments for 9927 Distributed Base Station Outdoor Cabinet with SEC-B (20 T1/E1 lines, maximum)

The following table provides the installer with T1/E1 line assignments for 9927 Distributed Base Station Outdoor Cabinet with four SEC-Bs. Because each SEC-B supports four T1/E1 lines, the cabinet can support up to 16 T1/E1 lines. The table below must be completed as part of site preparation.

SEC-B	T1/E1 Line #	Function Tx/Rx	RJ-45 Pinout #	Wire Color
1	1	Rx ____-T	1	White-Orange
		Rx ____-R	2	Orange-White
		Tx ____-T	4	White-Blue
		Tx ____-R	5	Blue-White
	2	Rx ____-T	1	White-Brown
		Rx ____-R	2	Brown-White
		Tx ____-T	4	White-Green
		Tx ____-R	5	Green-White
	3	Rx ____-T	1	Red-Blue
		Rx ____-R	2	Blue-Red
		Tx ____-T	4	White-Gray
		Tx ____-R	5	Gray-White
	4	Rx ____-T	1	Red-Green
		Rx ____-R	2	Green-Red
		Tx ____-T	4	Red-Orange
		Tx ____-R	5	Orange-Red

SEC-B	T1/E1 Line #	Function Tx/Rx	RJ-45 Pinout #	Wire Color
2	5	Rx ____-T	1	White-Orange
		Rx ____-R	2	Orange-White
		Tx ____-T	4	White-Blue
		Tx ____-R	5	Blue-White
	6	Rx ____-T	1	White-Brown
		Rx ____-R	2	Brown-White
		Tx ____-T	4	White-Green
		Tx ____-R	5	Green-White
	7	Rx ____-T	1	Red-Blue
		Rx ____-R	2	Blue-Red
		Tx ____-T	4	White-Gray
		Tx ____-R	5	Gray-White
	8	Rx ____-T	1	Red-Green
		Rx ____-R	2	Green-Red
		Tx ____-T	4	Red-Orange
		Tx ____-R	5	Orange-Red
3	9	Rx ____-T	1	White-Orange
		Rx ____-R	2	Orange-White
		Tx ____-T	4	White-Blue
		Tx ____-R	5	Blue-White
	10	Rx ____-T	1	White-Brown
		Rx ____-R	2	Brown-White
		Tx ____-T	4	White-Green
		Tx ____-R	5	Green-White
	11	Rx ____-T	1	Red-Blue
		Rx ____-R	2	Blue-Red
		Tx ____-T	4	White-Gray
		Tx ____-R	5	Gray-White
	12	Rx ____-T	1	Red-Green
		Rx ____-R	2	Green-Red
		Tx ____-T	4	Red-Orange
		Tx ____-R	5	Orange-Red

SEC-B	T1/E1 Line #	Function Tx/Rx	RJ-45 Pinout #	Wire Color
4	13	Rx ____-T	1	White-Orange
		Rx ____-R	2	Orange-White
		Tx ____-T	4	White-Blue
		Tx ____-R	5	Blue-White
	14	Rx ____-T	1	White-Brown
		Rx ____-R	2	Brown-White
		Tx ____-T	4	White-Green
		Tx ____-R	5	Green-White
	15	Rx ____-T	1	Red-Blue
		Rx ____-R	2	Blue-Red
		Tx ____-T	4	White-Gray
		Tx ____-R	5	Gray-White
	16	Rx ____-T	1	Red-Green
		Rx ____-R	2	Green-Red
		Tx ____-T	4	Red-Orange
		Tx ____-R	5	Orange-Red



---

## Site preparation for User Alarm cables

### User Alarm requirements

Each generated User Alarm is generated by a set of isolated dry relay contacts.

An “alarm state” may be indicated by a “closed circuit” or an “open circuit.”

- If an alarm condition is indicated by a “closed circuit,” the alarm contacts must present a contact closure when the alarm circuit fails or loses power.
- If an alarm condition is indicated by an “open circuit,” the alarm contacts must present an “open circuit” when the alarm circuit fails or loses power.

The resistance of a “closed circuit” is less than 100 ohms. The resistance of an “open circuit” is greater than 1 megohm.

The User Alarm switches (if desired) must be installed as part of site preparation. The 9927 Distributed Base Station Outdoor Cabinet cabinet is equipped with primary surge protection.

### User Alarm cable connections

The table below provides the pin numbers, wire colors, and functions for the User Alarm cables in the 9927 Distributed BTS outdoor cabinet.

Facilities cable	37 pin D-Sub	Wire Color	Cable 1 function	Cable 2 function
User Alarm cable	1	White-Blue	USERALM0 (+)	USERALM16 (+)
	20	Blue-White	USERALM0 (-)	USERALM16 (-)
	2	White-Orange	USERALM1 (+)	USERALM17 (+)
	21	Orange-White	USERALM1 (-)	USERALM17 (-)
	3	White-Green	USERALM2 (+)	USERALM18 (+)
	22	Green-White	USERALM2 (-)	USERALM18 (-)
	4	White-Brown	USERALM3 (+)	USERALM19 (+)
	23	Brown-White	USERALM3 (-)	USERALM19 (-)
	5	White-Gray	USERALM4 (+)	USERALM20 (+)
	24	Gray-White	USERALM4 (-)	USERALM20 (-)
	6	Red-Blue	USERALM5 (+)	USERALM21 (+)
	25	Blue-Red	USERALM5 (-)	USERALM21 (-)
	7	Red-Orange	USERALM6 (+)	USERALM22 (+)
	26	Orange-Red	USERALM6 (-)	USERALM22 (-)
	8	Red-Green	USERALM7 (+)	USERALM23 (+)
	27	Green-Red	USERALM7 (-)	USERALM23 (-)
	9	Red-Brown	USERALM8 (+)	USERALM24 (+)
	28	Brown-Red	USERALM8 (-)	USERALM24 (-)
	10	Red-Gray	USERALM9 (+)	USERALM25 (+)
	29	Gray-Red	USERALM9 (-)	USERALM25 (-)
	11	Black-Blue	USERALM10 (+)	USERALM26 (+)
	30	Blue-Black	USERALM10 (-)	USERALM26 (-)
	12	Black-Orange	USERALM11 (+)	USERALM27 (+)
	31	Orange-Black	USERALM11 (-)	USERALM27 (-)
	13	Black-Green	USERALM12 (+)	USERALM28 (+)
	32	Green-Black	USERALM12 (-)	USERALM28 (-)
	14	Black-Brown	USERALM13 (+)	USERALM29 (+)
	33	Brown-Black	USERALM13 (-)	USERALM29 (-)
	15	Black-Gray	USERALM14 (+)	USERALM30 (+)
	34	Gray-Black	USERALM14 (-)	USERALM30 (-)
	16	Yellow-Blue	USERALM15 (+)	USERALM31 (+)

---

Facilities cable	37 pin D-Sub	Wire Color	Cable 1 function	Cable 2 function
35	Blue- Yellow	USERALM15 (-)	USERALM31 (-)	



# 15 Hybriflex cable specifications

## Overview

### Purpose

This chapter discusses the fiber optic cable requirements for the RRHs. The fiber optic cables are contained within the Hybriflex cable.

### Contents

<a href="#">General facilities requirements</a>	15-2
<a href="#">Facilities requirements</a>	15-3
<a href="#">Requirements for Hybriflex cable</a>	15-4

---

## General facilities requirements

### General requirements

One fiber optic cable (from Hybriflex cable) is connected to each RRH.

The fiber optic cables that exit the Hybriflex cable are terminated with LC connectors.

All facilities must be available before the RRHs can be installed.

# Facilities requirements

## Hybriflex connection at DC Distribution/Fiber Management Box

The Hybriflex cable enters the DC Distribution/Fiber Management Box via a 1-1/2 inch knockout at the bottom panel of the DC Distribution/Fiber Management Box.

## Connectors on bottom of RRHs

The figure below shows the cable entry points on the bottom of the 800 MHz RRH.

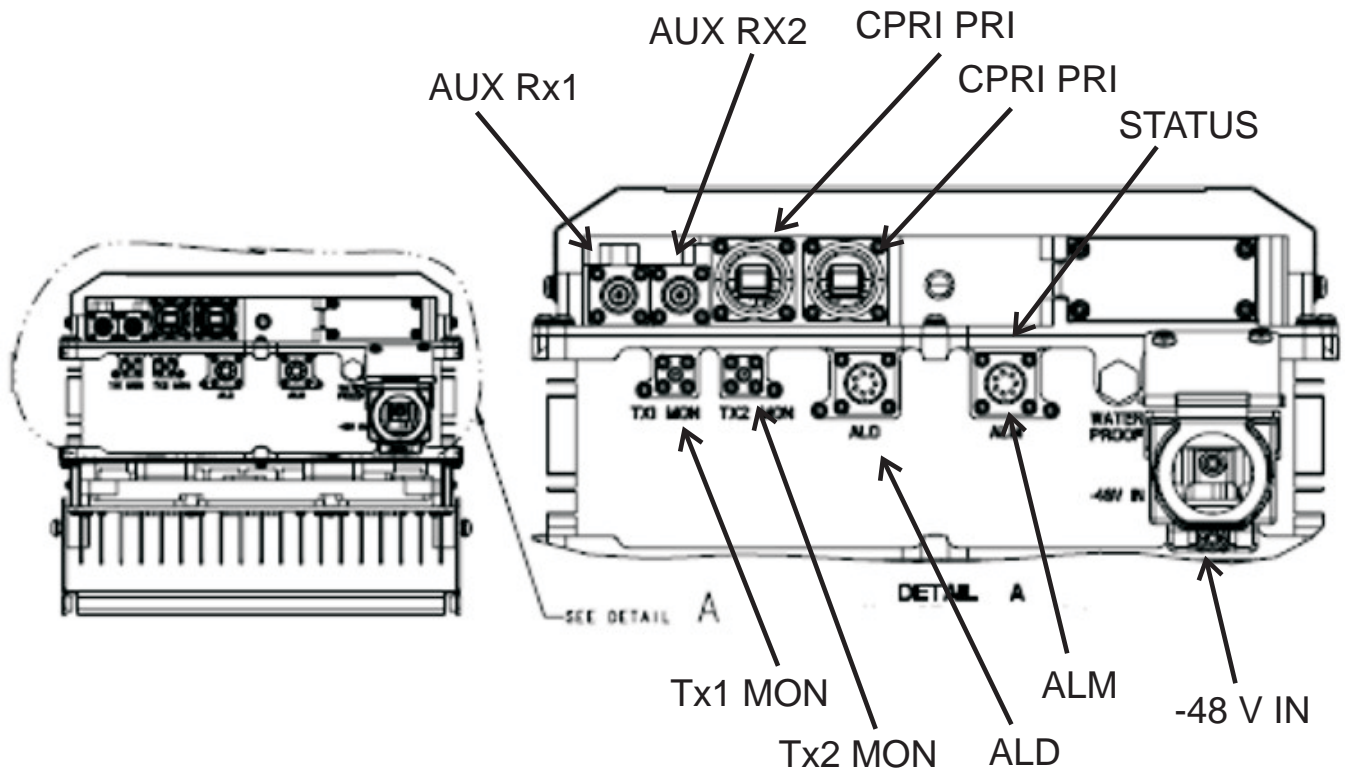

---

## Requirements for Hybriflex cable

### Overview

This section specifies the requirements for the Hybriflex cable, which connects the DC Distribution/Fiber Management Box to the RRH. The Hybriflex cable contains fiber optic and DC power cables.

### Hybriflex cable between DC Distribution/Fiber Management Box and RRHs

The fiber optic and DC power cables branch out at the pole end from the Hybriflex cable. The individual cables are 4.6 m (15 feet) long.

The Hybriflex cable provided by Alcatel-Lucent meets the following requirements:

- Outdoor rated
- Temperature rating: operation -40 to +85 °C (-40 to 185 °F), storage -55 to +85 °C (-67 to 185 °F)
- Bend radius: 15 x outside diameter (15 x \_\_\_ mm = \_\_\_\_\_ mm)
- Fiber count: 5
- DC power wire count: 4 pairs
- Fiber type: multi-mode
- Attenuation: 0.5 dB/km
- Rugged cable
- Connectors: LC duplex connectors are provided at both ends of fiber cables.
- Maximum tensile load; 800 newtons for installation
- Maximum tensile load; 500 newtons for operation
- UL 1666, flame retardent
- UL listed type OFNR

An excess cable length must be coiled at one or both ends and properly protected.

**Note:** To avoid damage to the fiber optic cable, extra care must be exercised by using fiber management paper and loosely fastening the fiber optic cable to the cable rack. The fiber optic cable bend radius must be as gradual as possible [15 x diameter of cable (15 x 7 mm = 105 mm)].

### Description of Hybriflex cable (supplied by Alcatel-Lucent)

The Hybriflex cable is routed from the DC Distribution/Fiber Management Box to the RRHs. It provides -48 VDC power and fiber optic links to each RRH.

The Hybriflex cable consists of a plastic coated, flexible metallic jacket that is weather and sunlight resistant. It contains six multi-mode fiber optic cables and four 8 AWG, stranded copper conductor pairs.



The fiber optic cables and DC cable pairs exit from each end of the Hybriflex cable. At the RRH end, the fiber optic cables and DC cable pairs are about 15 feet long. At the DC Distribution/Fiber Management Box end, they are about \_\_\_ feet long. Each fiber optic cable is terminated at each end with an LC connector. All cables are weather and sunlight resistant.

Shown in the figure below is the RRH end (or top end) of the Hybriflex cable.

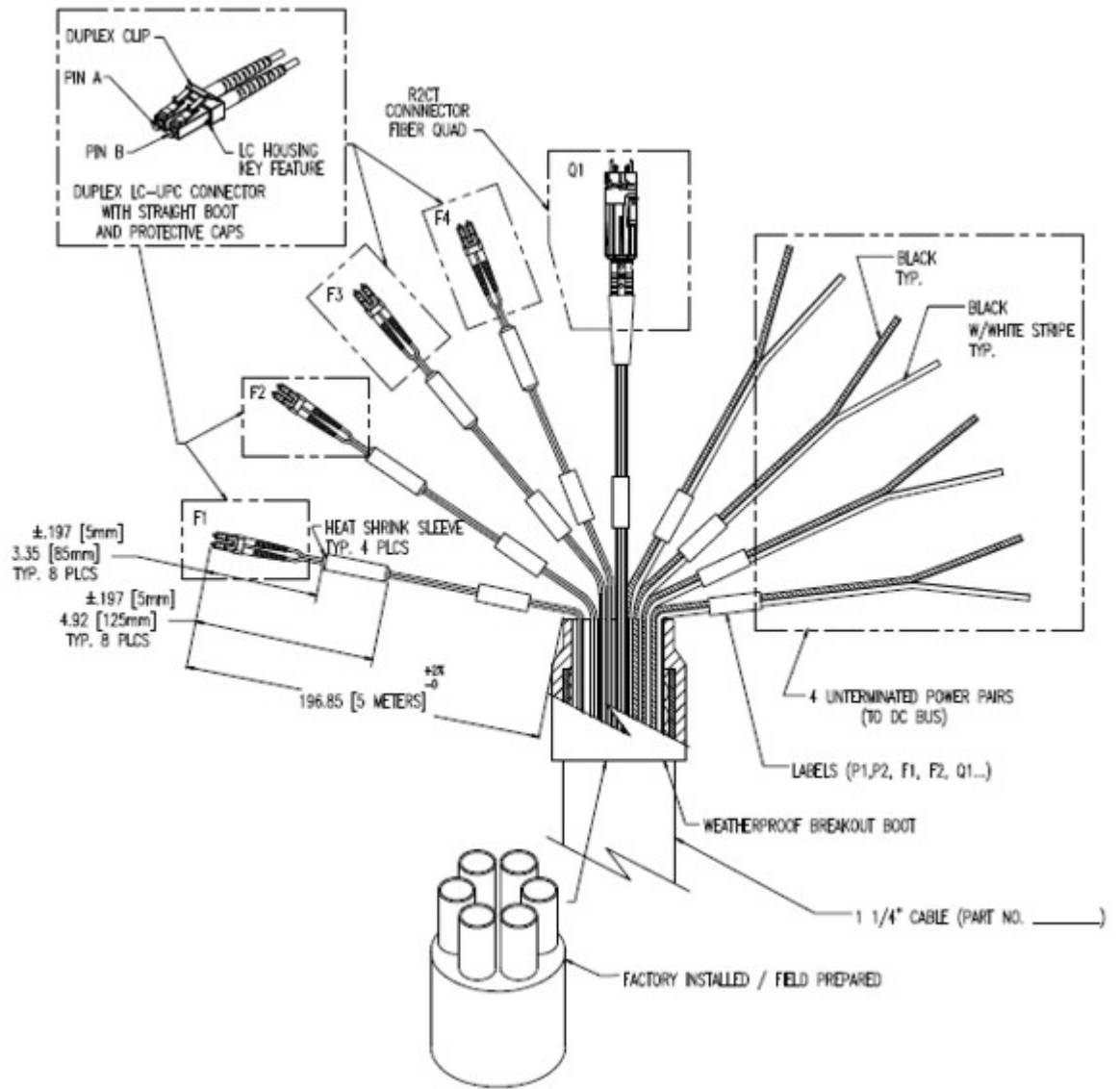

Shown in the figure below is the DC Distribution/Fiber Management Box end (or bottom end) of the Hybriflex cable.

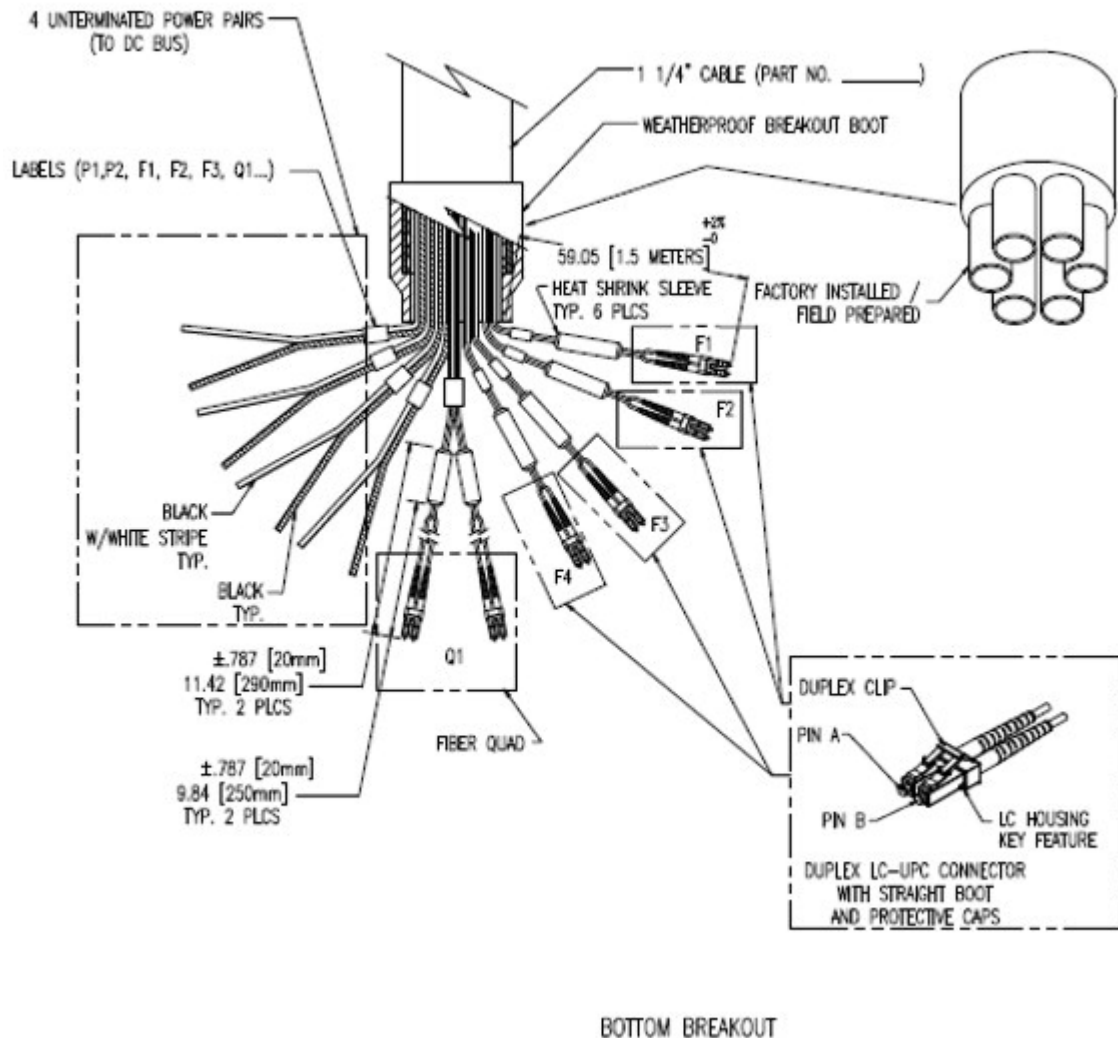

### DC Distribution/Fiber Management Box

The DC Distribution/Fiber Management Box goes between the baseband cabinet and the RRHs.

The DC Distribution/Fiber Management Box contains:

- DC surge protectors
- DC circuit breakers
- DC terminal blocks
- Fiber optic cable interface connectors

The fiber optic cable interface connectors couple the fiber optic cables from the 9927 Distributed BTS outdoor cabinet with the fiber optic cables in the Hybriflex cable

The DC Distribution/Fiber Management Box must be located at the bottom of the tower, within 20 feet of the 9927 Distributed BTS outdoor cabinet.

The requirements for the DC Distribution/Fiber Management Box are as follows:

- Outdoor rated
- UL listed
- Contains six round holes for Hybriflex and 1-1/2 inch liquid-tight flexible metallic conduit from the 9228 Distributed BTS outdoor cabinet.
- Contains 48 fiber optic (LC connector) interface connectors (connect fiber optic cable from Hybriflex cable to fiber optic cable from 9927 Distributed BTS)
- Two DC surge protectors with the option to go up to four.
- Contains 12 25 Amp, DC circuit breakers (can go up to 24)
- DC terminal block
- Must be Installed within 6.1 m (20 feet) of the 9927 Distributed BTS outdoor cabinet.

The block diagram below shows two 1–1/2 liquid-tight flexible metallic conduits and one Hybriflex cable entering the DC Distribution/Fiber Management Box.

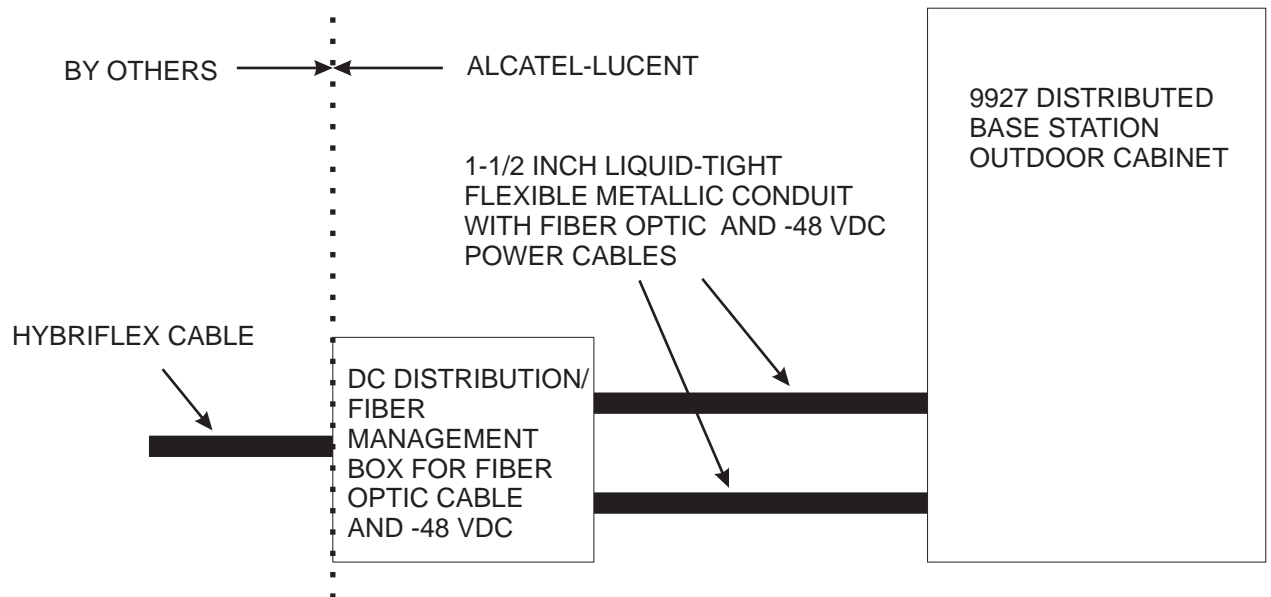

### Optical links between 9927 Distributed BTS cabinet and RRHs

The optical links between the baseband cabinet and DC Distribution/Fiber Management Box and DC Distribution/Fiber Management Box and RRHs are via multi-mode duplex fibers: two fibers -- one for Transmit (Tx) and one for Receive (Rx). When connecting the

9927 Distributed BTS cabinet to the RRHs, make certain fiber cable connector “B” is connected to Tx on the 9927 Distributed BTS cabinet and fiber cable connector “A” is connected to Rx on the RRH.

**Important!** “A” and “B” designations are typically imprinted on the LC connector clip.

The following figure shows a typical fiber cable with LC duplex connectors at the baseband cabinet and RRH end.

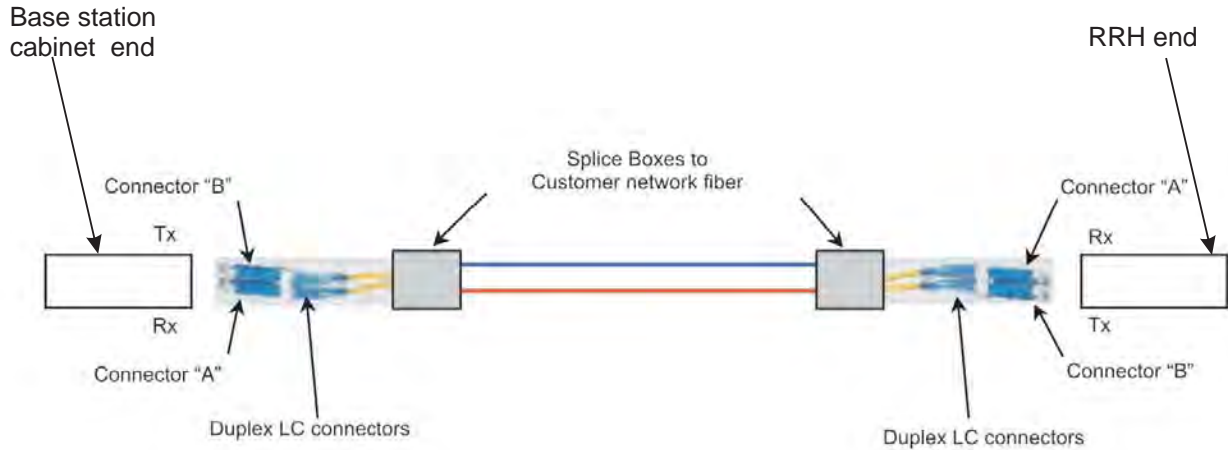

# Appendix A: 9927 Distributed Base Station Outdoor Cabinet site preparation checklists

## Overview

### Purpose

This section is for use by authorized personnel to verify completion of cell site preparation activities prior to installation of base station equipment.

### Contents

<a href="#">SP-GEN Cell site general information form</a>	<a href="#">A-2</a>
<a href="#">SP-1 Site preparation general checklist</a>	<a href="#">A-3</a>
<a href="#">SP-2 Site preparation power source checklist</a>	<a href="#">A-5</a>
<a href="#">SP-3 Site preparation grounding checklist</a>	<a href="#">A-6</a>
<a href="#">SP-5 Site preparation GPS antenna checklist</a>	<a href="#">A-9</a>
<a href="#">SP-6 Site preparation punchlist sheet</a>	<a href="#">A-11</a>
<a href="#">SP-6A Site preparation punchlist sheet</a>	<a href="#">A-12</a>

---

## SP-GEN Cell site general information form

### Purpose

The following form must be completed prior to the installation of the cell site equipment.

### Form

Complete the following information about the cell site.

- Cell Site Name: \_\_\_\_\_
- Cell Site Address: \_\_\_\_\_
- Cell Site Access Contact Name: \_\_\_\_\_
- MTA Name: \_\_\_\_\_
- Cell Site # : \_\_\_\_\_
- Contact Phone # : \_\_\_\_\_

## SP-1 Site preparation general checklist

### Purpose

The following items must be completed prior to the installation of the cell site equipment. Circle the correct letter for the corresponding item descriptions.

### Checklist

Item #	Description	Yes (Y)	No (N)	N/A	Comments
1.	Is the work site free of environmental, health and safety (EH&S) hazards?	Y	N	N/A	
2.	Are cell site environmental conditions within equipment specified operating range?	Y	N	N/A	
3.	Has the optional ice bridge been installed?	Y	N	N/A	
4.	Has the required space been provided around equipment (that is, maintenance access, cabinets, heat dissipation, safety) ?	Y	N	N/A	
5.	Is support structure properly secured and anchored per earthquake zoning requirements?	Y	N	N/A	
6.	Will structure support cabinets/equipment (including batteries, etc.) ?	Y	N	N/A	
7.	Are all site permits completed?	Y	N	N/A	
8.	Has a Method of Procedure (MOP) been developed with the installation supervisor?	Y	N	N/A	
9.	Is cell translations information available?	Y	N	N/A	
10.	Has installer cell site equipment parameter sheet been completed and reviewed with the installation supervisor?	Y	N	N/A	
11.	Are the ECP/Switch and cell software generics compatible?	Y	N	N/A	
12.	Are T1/E1 and User Alarm facilities available and active?	Y	N	N/A	
13.	If T1/E1 facility is 75 ohms coaxial, has the protection/conversion of coaxial cable to twisted-pair cable been provided?	Y	N	N/A	

Item #	Description	Yes (Y)	No (N)	N/A	Comments
14.	Is adequate primary surge protection provided for the T1/E1 service entrance?	Y	N	N/A	
15.	Are the T1/E1 long enough to reach from the T1/E1 service entrance to the punchdown block or conversion block?	Y	N	N/A	
16.	Is the conduit for routing T1/E1 and User Alarm cables to the basestand frame in place?	Y	N	N/A	
17.	Is the twisted-pair cable installed and protected for T1/E1?	Y	N	N/A	
18.	Is the twisted-pair cable installed and protected for User Alarm?	Y	N	N/A	
19.	Has all equipment been ordered and has delivery to site been scheduled?	Y	N	N/A	
20.	Have all necessary arrangements been made for access to the site?	Y	N	N/A	
21.	Have all necessary arrangements been made to get equipment onto the site (crane, etc.) ?	Y	N	N/A	

Completed by: _____
Date: _____



## SP-2 Site preparation power source checklist

### Purpose

The following items must be completed prior to the installation of the cell site equipment. Circle the correct letter for the corresponding item descriptions.

### Checklist

Item #	Description	Yes (Y)	No (N)	N/A	Comments
1.	Is AC service available?	Y	N	N/A	
2.	Have AC service and conduits been approved by local code?	Y	N	N/A	
3.	Is AC service equipped with surge protection at service entry point?	Y	N	N/A	
4.	Is AC power source appropriate for equipment being installed?	Y	N	N/A	
5.	Does AC service have proper circuit breaker rating(s) and labeling?	Y	N	N/A	
6.	Is AC circuit breaker(s) available and labeled for power system?	Y	N	N/A	
7.	Is AC circuit breaker(s) available and labeled for listed ancillary equipment?	Y	N	N/A	
	A.	Y	N	N/A	
	B.	Y	N	N/A	
	C.	Y	N	N/A	
8.	Do tower lighting, intrusion lighting, etc. feeds have proper lightning protection?	Y	N	N/A	
9.	If not supplied with the cabinets, have at least two AC duplex convenience outlets been provided within 1.5 meters (5 feet) of basestand frame(s)?  NOTE: A Ground Fault Circuit Interrupt (GFCI) type is recommended, and must be used when required by code.	Y	N	N/A	
10.	Is each outlet protected by a UL/CSA listed, or approved 15 A circuit breaker?	Y	N	N/A	

# SP-3 Site preparation grounding checklist

## Purpose

The following items must be completed prior to the installation of the cell site equipment. Circle the correct letter for the corresponding description items.

## Checklist

Item #	Description	Yes (Y)	No (N)	N/A	Comments
1.	Is soil resistivity and site resistance test on file?	Y	N	N/A	
2.	Has connection been provided to grounding electrode system? If yes, circle all that apply: 1. Via a buried ring ground and driven rod(s) 2. Via a buried metallic and electrically continuous water pipe 3. Via driven ground rod(s) and/or plate(s) 4. Via electrolytic ground rod(s) 5. Via grounded building steel 6. Via grounded grid or radial	Y	N	N/A	
3.	Is lighting mast(s) or air terminal(s) provided and bonded?	Y	N	N/A	
4.	Is antenna support structure(s) grounded?	Y	N	N/A	
5.	Is antenna tower bonded to grounding electrode system?	Y	N	N/A	
6.	Are guy wires bonded to grounding electrode system?	Y	N	N/A	
7.	Are antenna cable shields grounded at both ends?	Y	N	N/A	
8.	If tower is greater than 60 meters (200 feet) high, are antenna cable shields grounded at midpoint and both ends?	Y	N	N/A	
9.	Is ice bridge bonded at both ends and 7.62-meter (25-foot) intervals?				

Item #	Description	Yes (Y)	No (N)	N/A	Comments
10.	Are all ground connections in compliance with Alcatel-Lucent requirements (exothermic weld, compression type with 2-hole lugs; properly secured; antioxidant used on contact surface area) ?	Y	N	N/A	
11.	Are all grounding conductors routed as straight as possible with no loops or sharp bends?	Y	N	N/A	
12.	Is cabinet support structure grounded?	Y	N	N/A	
13.	Are metallic conduits bonded at both ends and 7.62 meter (25 foot) intervals?	Y	N	N/A	
14.	Are all fence corner posts and gate posts properly grounded (including fence fabric and barbed wire, as applicable) ?	Y	N	N/A	
15.	Are all metallic objects in the vicinity bonded to the grounding system?	Y	N	N/A	
16.	Is AC power supply equipped with a surge protection device and is the device properly connected to the ground system?	Y	N	N/A	
17.	Is T1/E1 line equipped with a surge protection device and is the device properly connected to the ground system?	Y	N	N/A	
18.	Is tower light system (if installed) equipped with a surge protection device and is the device properly connected to the ground system?	Y	N	N/A	
19.	Are the GPS antenna cable shields properly grounded? Is surge protection in place and properly grounded GPS antenna?	Y	N	N/A	
21.	Is supplementary conductor connected to grounding electrode system? (Exposed end, if any, must be taped.)	Y	N	N/A	

Item #	Description	Yes (Y)	No (N)	N/A	Comments
22.	Are down conductors in compliance with Alcatel-Lucent specifications?  (If building is less than 23 meters (75 ft.) high, use two 33.6 mm <sup>2</sup> (2 AWG) copper conductors. If higher than 23 meters (75 feet), use two 2/0 copper conductors).	Y	N	N/A	
23.	Is steel column used as one down conductor?	Y	N	N/A	
	<i>Concrete Pad Cell Site Installation Only</i>				
24.	Is supplementary conductor connected to grounding electrode system at both ends (if applicable) ?	Y	N	N/A	
25.	Were buried ring ground and its connections inspected before the trench was backfilled?	Y	N	N/A	
26.	Was a photo taken of the buried ring ground and its connections prior to back-filling for reference file?	Y	N	N/A	

Completed by:	_____
Date:	_____

## SP-5 Site preparation GPS antenna checklist

### Purpose

The following items must be completed prior to the installation of the cell site equipment. Circle the correct letter for the corresponding item descriptions.

### Checklist

Item #	Description	Yes (Y)	No (N)	N/A	Comments
1.	Is antenna installed with base level within two degrees?	Y	N	N/A	
2.	Is antenna installed with less than 25% of the sky masked by obstruction?	Y	N	N/A	
3.	Is GPS antenna located at least 3.05 m (10 feet) vertically and horizontally from any active transmit antenna?	Y	N	N/A	
4.	Are aggregate cable loss, cable Voltage Standing Wave Ratio (VSWR), total cable length, cable type, GPS antenna gain, KS list and serial numbers recorded in the site installation records?	Y	N	N/A	
5.	Is proper gain antenna installed for the total aggregate cable loss and length?	Y	N	N/A	
6.	Is measured cable VSWR within its specified value?	Y	N	N/A	
7.	Is GPS antenna cable properly grounded, and equipped with proper surge protection device?	Y	N	N/A	
8.	Are proper service loops provided near antenna?	Y	N	N/A	
9.	Is proper drip loop provided at the 9927 Distributed Base Station Outdoor Cabinet antenna cable cover?	Y	N	N/A	
10.	Are cable connections torqued to the appropriate value?	Y	N	N/A	
12.	Are all external cables UV rated?	Y	N	N/A	
13.	Are antenna bracket, pipes, and antenna properly secured?	Y	N	N/A	

Item #	Description	Yes (Y)	No (N)	N/A	Comments
14.	Was GPS antenna location verified for line of sight using a Garmin 45XL test unit or equivalent?	Y	N	N/A	
15.	Is GPS antenna location free of external interference (i.e., radio stations, collocated equipment, etc.) ?	Y	N	N/A	

Completed by: _____
Date: _____

# SP-6 Site preparation punchlist sheet

## Purpose

The following punchlist is used to track any outstanding site preparation items.

## Punchlist

Item #	Comment/Description	Severity (1/2/3)	Corrective Action Required	
			(Y/N)	Completed Date

### Severity Column Definitions:

1. Equipment installation cannot occur until outage is rectified and will void warranty or potentially cause personal injury.
2. Equipment installation can occur but issue must be rectified prior to hand-off to customer or service turn-up so that the warranty is not voided.
3. Equipment installation, hand-off to customer, or service turn-up can occur but not per Alcatel-Lucent recommendations.

### Inspection Checklist Completion Sign-Off

Was the punchlist continuation sheet on the next page used?	<input type="checkbox"/> Yes	<input type="checkbox"/> No
Inspector's Name:	_____	
Inspector's Signature:	_____	
Date:	_____	





# Appendix B: Site preparation checklists for RRHs

## Overview

### Purpose

This section is for use by authorized personnel to verify completion of cell site preparation activities prior to installation of base station equipment.

### Contents

SP-GEN cell site general information	B-2
SP-1 Site preparation general checklist	B-3
SP-2 Site preparation power source checklist	B-6
SP-3 Site preparation grounding checklist	B-7
SP-4 Site preparation RF antenna checklist	B-9
SP-5 Site preparation punchlist sheet	B-11
SP-5A Site preparation punchlist sheet	B-12

---

## SP-GEN cell site general information

Complete the following information about the cell site:

- Cell Site Name: \_\_\_\_\_
- Cell Site Address: \_\_\_\_\_
- Cell Site Access Contact Name: \_\_\_\_\_
- MTA Name: \_\_\_\_\_
- Cell Site #: \_\_\_\_\_
- Contact Phone #: \_\_\_\_\_.

## SP-1 Site preparation general checklist

### Purpose

The following items must be completed prior to the installation of the cell site equipment. Circle the correct letter for the corresponding item descriptions.

Item #	Description	Yes (Y)	No (N)	N/A	Comments
1.	Are cell site environmental conditions within equipment specified operating range?	Y	N	N/A	
2.	Has the required space been provided around equipment [i.e., maintenance access, cabinet(s), heat dissipation, safety]?	Y	N	N/A	
3.	Has a Method of Procedure (MOP) been developed with the installation supervisor?	Y	N	N/A	
4.	Is cell translations information available?	Y	N	N/A	
5.	Has installer cell site equipment parameter sheet been completed and reviewed with the installation supervisor?	Y	N	N/A	
6.	Are the ECP/Switch and cell software generics compatible?	Y	N	N/A	
7.	Are user alarm facilities available and active?	Y	N	N/A	
8.	Is adequate primary surge protection provided for the user alarms?	Y	N	N/A	
9.	Have the user alarm cables been installed and terminated in the alarm interface and alarm block (or equivalent)?	Y	N	N/A	
10.	Are fiber optic facilities (splicing/DC Distribution/Fiber Management Box) available and active?	Y	N	N/A	

Item #	Description	Yes (Y)	No (N)	N/A	Comments
11.	Have the fiber optic cables been installed for termination at the ALU equipment or at the demarcation point (slicing/DC Distribution/Fiber Management Box)?	Y	N	N/A	
12.	Is the RRH and distributed base station (9234 d2U or 9222 or 9228) going to be co-located or within 328 ft.?	Y	N	N/A	
13.	Is the Standard Fiber Cable assembly (15 ft., 50 ft., 100 ft., etc.) installed and available at the site?	Y	N	N/A	
14.	Is the RRH and distributed base station (9234 d2U or 9222 or 9228) installed as non-co-located separated more than 328 ft.?	Y	N	N/A	
15.	Has the customer supplied and installed Splicing/Junction Boxes at both RRH and distributed base station (9234 d2U or 9222 or 9228) sides?	Y	N	N/A	
16.	Has the customer supplied and installed proper fiber between the Splicing/Junction Boxes ?	Y	N	N/A	
17.	Is there a standard 50 ft. fiber cable assembly installed and available from Splicing/DC Distribution/Fiber Management Box to near the distributed base station (9234 d2U or 9222 or 9228) and RRH frames?	Y	N	N/A	
18.	Is the fiber cable properly protected and extra length (if any) coiled up and stored properly?				
19.	Has all equipment been ordered and has delivery to site been scheduled?	Y	N	N/A	
20.	Have all necessary arrangements been made for access to the site?	Y	N	N/A	
21.	Have all necessary arrangements been made to get equipment onto the site (crane, etc.)?	Y	N	N/A	

---

**Notes:**

1. Completed by: \_\_\_\_\_
2. Date: \_\_\_\_\_

## SP-2 Site preparation power source checklist

### Purpose

The following items must be completed prior to the installation of the cell site equipment. Circle the correct letter for the corresponding item descriptions.

Item #	Description	Yes (Y)	No (N)	N/A	Comments
1.	Is AC / DC service available?	Y	N	N/A	
2.	Have AC / DC service and conduits been approved by local code?	Y	N	N/A	
3.	Is AC / DC service equipped with surge protection at service entry point?	Y	N	N/A	
4.	Is AC / DC power source appropriate for equipment being installed?	Y	N	N/A	
5.	Does AC / DC service have proper circuit breaker rating(s) and labeling?	Y	N	N/A	
6.	Is AC / DC circuit breaker(s) available and labeled for power system?	Y	N	N/A	
7.	Is AC / DC circuit breaker(s) available and labeled for listed ancillary equipment?	Y	N	N/A	
	A.	Y	N	N/A	
	B.	Y	N	N/A	
	C.	Y	N	N/A	
8.	Do tower lighting, intrusion lighting, etc. feeds have proper lightning protection?	Y	N	N/A	
9.	If not supplied with the cabinets, have at least two AC duplex convenience outlets been provided within 1.5 meters (5 feet) of radio cabinet(s)?  NOTE: A Ground Fault Circuit Interrupt (GFCI) type is recommended, and must be used when required by code.	Y	N	N/A	
10.	Is each outlet protected by a UL/CSA listed, or approved 15 A circuit breaker?	Y	N	N/A	

## SP-3 Site preparation grounding checklist

### Purpose

The following items must be completed prior to the installation of the cell site equipment. Circle the correct letter for the corresponding description items.

Item #	Description	Yes (Y)	No (N)	N/A	Comments
1.	Is soil resistivity and site resistance test on file?	Y	N	N/A	
2.	Has connection been provided to grounding electrode system? If yes, circle all that apply: A. Via a buried ring ground and driven rod(s) B. Via a buried metallic and electrically continuous water pipe C. Via driven ground rod(s) and/or plate(s) D. Via electrolytic ground rod(s) E. Via grounded building steel F. Via grounded grid or radial	Y	N	N/A	
3.	Is lighting mast(s) or air terminal(s) provided and bonded?	Y	N	N/A	
4.	Is antenna support structure(s) grounded?	Y	N	N/A	
5.	Is antenna tower bonded to grounding electrode system?	Y	N	N/A	
6.	Are guy wires bonded to grounding electrode system?	Y	N	N/A	
7.	Are antenna cable shields grounded at both ends?	Y	N	N/A	
8.	If tower is greater than 60 meters (200 ft.) high, are antenna cable shields grounded at mid-point and both ends?	Y	N	N/A	
9.	Is ice bridge bonded at both ends and 7.62-meter (25-foot) intervals?	Y	N	N/A	

Item #	Description	Yes (Y)	No (N)	N/A	Comments
10.	Are all ground connections in compliance with Alcatel-Lucent requirements (exothermic weld, compression type with 2-hole lugs; properly secured; anti-oxidant used on contact surface area)?	Y	N	N/A	
11.	Are all grounding conductors routed as straight as possible with no loops or sharp bends?	Y	N	N/A	
12.	Is cabinet support structure grounded?	Y	N	N/A	
13.	Are metallic conduits bonded at both ends and 7.62 meter (25 foot) intervals?	Y	N	N/A	
14.	Are all fence corner posts and gate posts properly grounded (including fence fabric and barbed wire, as applicable)?	Y	N	N/A	
15.	Are all metallic objects within 1.8 meters (6 feet) bonded to the grounding system?	Y	N	N/A	
16.	Is AC / DC power supply equipped with a surge protection device and is the device properly connected to the ground system?	Y	N	N/A	
17.	Is tower light system (if installed) equipped with a surge protection device and is the device properly connected to the ground system?	Y	N	N/A	
18.	Are the RF surge protection devices properly connected to the ground system?	Y	N	N/A	

**Notes:**

1. Completed by: \_\_\_\_\_
2. Date: \_\_\_\_\_



## SP-4 Site preparation RF antenna checklist

### Purpose

The following items must be completed prior to the installation of the RF cell site equipment. Circle the correct letter for the corresponding item descriptions.

Item #	Description	Yes (Y)	No (N)	N/A	Comments
1.	Is tower properly installed and secured?	Y	N	N/A	
2.	Are all antenna cable runs installed?	Y	N	N/A	
3.	Are all antenna cable runs properly terminated with 7/16 DIN female connectors on the equipment side?	Y	N	N/A	
4.	Are all cable connections torqued to the appropriate value?	Y	N	N/A	
5.	Are the RF antenna cables equipped with surge protection devices?				
6.	Are all external cables UV rated?	Y	N	N/A	
7.	Are antenna cable runs' demarcation points in proper location?	Y	N	N/A	
8.	Are antenna cable runs marked and in proper sequence per applicable equipment drawings?	Y	N	N/A	
9.	Are appropriate type, length and number of antenna cable jumpers available?	Y	N	N/A	
10.	Are appropriate drip loops provided for antenna cable runs at turns and demarcation point?	Y	N	N/A	
11.	Have antenna and cable sweeps been performed?	Y	N	N/A	
12.	Are antennas properly installed and secured?	Y	N	N/A	
13.	Are all antennas the proper type?	Y	N	N/A	
14.	Are all antennas at proper azimuth? (0,120 or 240 degrees)	Y	N	N/A	
15.	Are antennas at proper height?	Y	N	N/A	
16.	Are antennas at proper tilt?	Y	N	N/A	

Item #	Description	Yes (Y)	No (N)	N/A	Comments
17.	Have diversity antennas been properly separated?	Y	N	N/A	
18.	Are antenna hatchplate and cable boots properly installed?	Y	N	N/A	

**Notes:**

1. Completed by: \_\_\_\_\_
2. Date: \_\_\_\_\_

# SP-5 Site preparation punchlist sheet

## Purpose

The following punchlist is used to track any outstanding site preparation items.

Item #	Comment/Description	Severity (1/2/3)	Corrective Action Required	
			(Y/N)	Completed Date

## Notes:

1. Equipment installation cannot occur until outage is rectified and will void warranty or potentially cause personal injury.
2. Equipment installation can occur but issue must be rectified prior to handoff to customer or service turn-up so that the warranty is not voided.
3. Equipment installation, handoff to customer, or service turn-up can occur but not per Lucent recommendations.
4. Inspection Checklist Completion Sign-Off (complete below)
5. Was the punchlist continuation sheet on the next page used? Yes or No
6. Inspector's Name: \_\_\_\_\_
7. Inspector's Signature: \_\_\_\_\_ Date: \_\_\_\_\_



# Appendix C: 9927 Distributed Base Station Outdoor Cabinet cell site information

## Overview

### Purpose

This section is for use by Customer Project Management to document cell site configuration information.

### Contents

<a href="#">CSC-1 Cell site configuration information</a>	C-2
---	-----

---

## CSC-1 Cell site configuration information

### General base station information

Complete the following cell site information:

Cell Site	information (provided by inspector)
Name	
Address	
Contact name	
MTA name	
Cell Site #	
Contact Phone & Pager #	

### Installation type

Check all that apply:

- Indoor
- Outdoor
- Controlled Environment
- Uncontrolled Environment
- Concrete Pad
- Rooftop
- Other (Specify) : \_\_\_\_\_

### Base station substructure

Check all that apply:

- Concrete
- Wood floor
- Raised floor
- Non-Penetrating
- I-beam
- C-beam
- Platform

**Earthquake zone rating**

Check one:

- Zone 0
- Zone 1
- Zone 2
- Zone 3
- Zone 4

**Base station equipment**

Complete the information for the 9927 Distributed Base Station Outdoor Cabinet equipment:

Cabinet Type	Serial #	# of sector	Duplex/ Triplex/ Dual Duplex
Primary cabinet			
Growth cabinets			
Battery cabinet			

**Antennas**

Complete the following (if required) :

PCS Channel # (1-1999) \_\_\_\_\_

# of Carriers (1-9) \_\_\_\_\_

GPS Antenna KS/Model \_\_\_\_\_

PCS Freq. Block (A-F) \_\_\_\_\_

GPS Cable Length (ft.) \_\_\_\_\_

GPS Antenna Gain (dB) \_\_\_\_\_

Microwave Antenna Type (\_\_\_\_\_) \_\_\_\_\_

**Power**

Total # of Battery Strings \_\_\_\_\_

Power source, if any

- -48 VDC

Integrated power?

- Yes
- No

External power?

- Yes
- No

Power collocated with base station equipment?

- Yes
- No

**Other cell site equipment**

Complete the following:

Equipment description	Yes (Y)	No (N)	N/A
Antenna Tower?	Y	N	N/A
FAA Lighting?	Y	N	N/A
Tower Light Alarm?	Y	N	N/A
Ice Bridge? Covering: (check one) ___ Cables Only ___ Cables and Equipment	Y	N	N/A
Cable Tray or Ladder Racks? Type of Ladder: (check one) ___ 5' Ladders ___ 12' Ladders ___ Other: ___	Y	N	N/A
Antenna Cable Hatch Plate? Number of Entry Holes ___	Y	N	N/A
Facilities Ancillary Equipment? Power Source: (check one) ___ AC ___ DC Voltage: (check one) ___ DC ___ rms	Y	N	N/A



Equipment description	Yes (Y)	No (N)	N/A
AC Service: Size (amps) ____ Voltage (v) ____ Phase (1 or 3) ____			
Customer-supplied Power System? NOTE: If YES, the customer is responsible for the configuration of the power system.	Y	N	
Earthquake Bracing Required?	Y	N	N/A
Tx/Rx Antenna? (mounting location) ____ Tower ____ Steel Structure ____ Building ____ Antenna Support Structure	Y	N	N/A
Cell Site Grounding? If YES, select all that apply: ____ Buried ring ground and driven rods ____ Buried metallic and electrically continuous water pipe ____ Down conductors (Quantity: ____) ____ Electrolytic ground rod(s) (Quantity : ____) ____ Driven ground rod(s) (Quantity : ____) ____ Grounded building steel ____ Ground grid ____ Ground radial(s) (Quantity : ____)	Y	N	
Collocated non-PCS equipment? Existing grounding system: ____ Single Point ____ Integrated	Y	N	
Ground Bus? If YES, quantity: ____	Y	N	



# Appendix D: Guidelines for lifting and moving cabinets

## Overview

### Purpose

This Appendix provides guidelines for lifting and moving the 9927 Distributed Base Station Outdoor Cabinet cabinets and the 60ECv2 battery cabinet.

### Contents

<a href="#">Lifting and moving cabinets</a>	D-2
---	-----

---

# Lifting and moving cabinets

## Purpose

Cabinets are usually shipped to the customer via truck and are delivered to the installation site. During installation, it may be necessary to lift the cabinet to move it to a new location. This section describes how to safely lift the cabinets. Use this information as you perform the lifting procedures.



### WARNING

#### Equipment damage

*A dolly with straps can damage the front air filter cover and the rear muffler cover of the 9927 cabinet if too much tension is applied to the straps.*

*When a dolly with straps is used to move the 9927 Distributed Base Station Outdoor Cabinet, adjust the straps and the tension so that the air filter cover and the rear muffler cover are not damaged by the straps.*

## Lifting machinery

To lift the cabinet, do one of the following:

- Use a forklift with forks that are at least 4 feet long to lift a cabinet attached to a pallet from the bottom.
- Install lifting eyebolts on the top of the cabinet, and use a derrick and slings to lift the cabinet from its top.

## Safety precautions for using lifting machinery



### WARNING

#### Personnel injury or equipment damage

*Cabinets are too heavy to move without appropriate lifting devices.*

*Derrick equipment or a forklift must be used to lift the cabinet. Do not attempt to move the cabinet manually, or remove it from the pallet manually.*

Comply with the following guidelines when using lifting machinery:

- Only operators who are specifically trained and meet company requirements should be permitted to operate derrick or forklift equipment.
- All persons working with derricks or forklifts must wear standard safety headgear, footwear, eye protection, and insulated gloves (if required).

- Do not operate a derrick until both stabilizers are extended and firmly supported. Do not extend stabilizers after a load is suspended from the derrick.
- While raising the derrick from the stowed position, be alert for overhead obstructions, such as power lines, that may interfere.
- At all times, keep bystanders away from the work area.
- Operators must not suspend loads over people, nor can any person be permitted to work, stand, or pass under a suspended load.
- When a cabinet is being lifted with slings, it is unsafe to lift the cabinet when lifting sling angle is less than 45 degrees to the top of the cabinet.

### Guidelines for using a derrick

When a derrick is used to move a cabinet, lifting eyebolts and slings are used to attach the cabinet to the derrick.

#### Lifting eyebolts



#### **DANGER**

#### **Cabinet lifting hazard!**

*When lifting cabinets, incorrect or improperly installed eyebolts will fail endangering personnel to bodily injury and destroying the equipment.*

*Avoid using the wrong eyebolts by following these guideline:*

- *If a ½ inch eyebolt threads easily and fully into a lifting nut on the top of the cabinet, then use the ½ inch eyebolts.*
- *If not, check the threads for 12 mm eyebolts. The 12 mm eyebolt should thread all the way down without binding, until it bottoms out.*
- *A 12 mm eyebolt is too small for a ½ inch lifting nut, but will not hand thread all the way into the ½-inch nut unless forced. It will cross thread if forced, and may pull out when hoisting, presenting a serious danger. Do NOT force 12 mm eyebolts into ½ inch lifting nuts. Doing so will damage the threads of the lifting nuts.*
- *A ½ inch eyebolt will thread less than half a thread into a 12 mm lifting nut. Do NOT force ½ inch eyebolts into 12 mm lifting nuts. Doing so will damage the threads of the lifting nuts.*

#### **Install lifting eyebolts on 9927 cabinets**

Four R-ITE-6110 M12, or Four R-ITE-6113 1/2-inch lifting eyebolts are screwed into the lifting nuts on the top of the cabinet, as shown in the following figure.

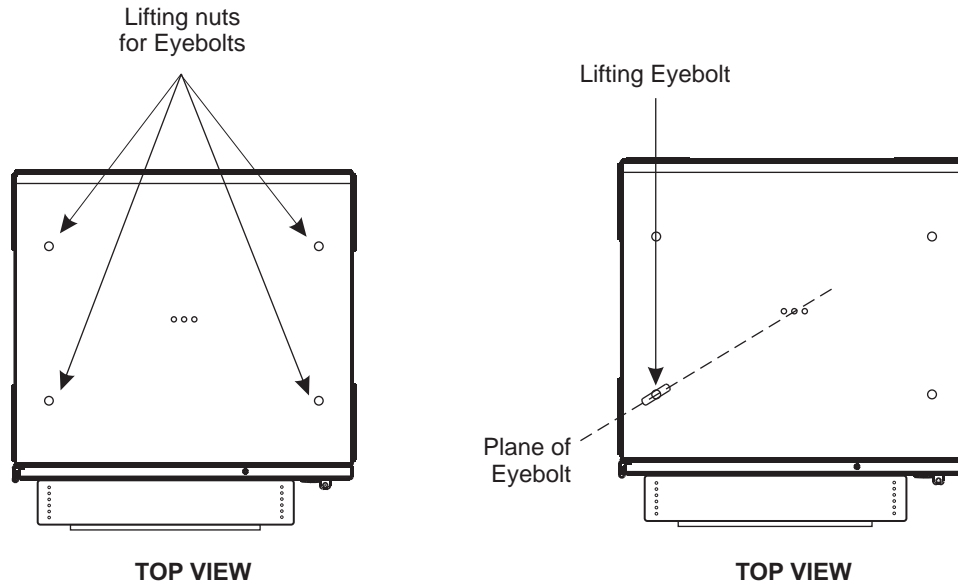

Position each lifting eyebolt so that the plane of the eyebolt points at the center of the top of the cabinet, as shown in the previous figure. When this is done, and the load is applied, the plane of the eyebolt will align with the load. Eyebolts that are not aligned with the load can bend as the load pulls on them sideways. Refer to the following figure for the correct method to install the lifting eyebolts.

**Install lifting eyebolts on 60ECv2 cabinet**

Two R-ITE-6113 1/2 inch lifting eyebolts are screwed into the lifting nuts on the top of the cabinet, as shown in the following figure.

**Important!** Do NOT use R-ITE-6110 M12 eyebolts to lift the 60ECv2 cabinet.

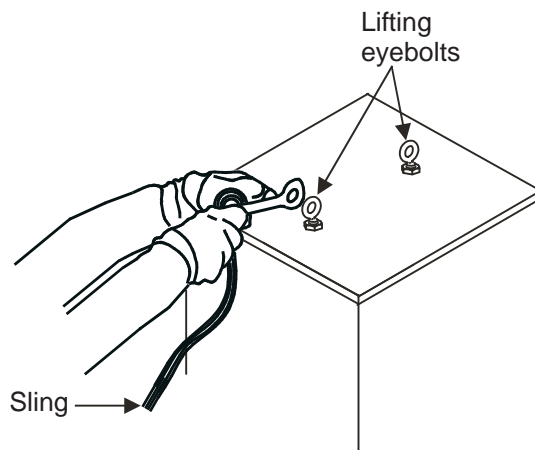

Secure each lifting eyebolt at the top of the cabinet, as shown in the previous figures, and ensure the shoulder of the eyebolts is properly seated. Refer to the following figure for the correct method to install the lifting eyebolts.

### Install lifting eyebolts

Note: Eyebolts are labeled  $\frac{1}{2}$  or **M12**.

The picture on the left illustrates the use of a M12 eyebolt on a  $\frac{1}{2}$ -inch nut.

The picture on the right illustrates the use of  $\frac{1}{2}$ -inch eyebolt on a  $\frac{1}{2}$ -inch nut

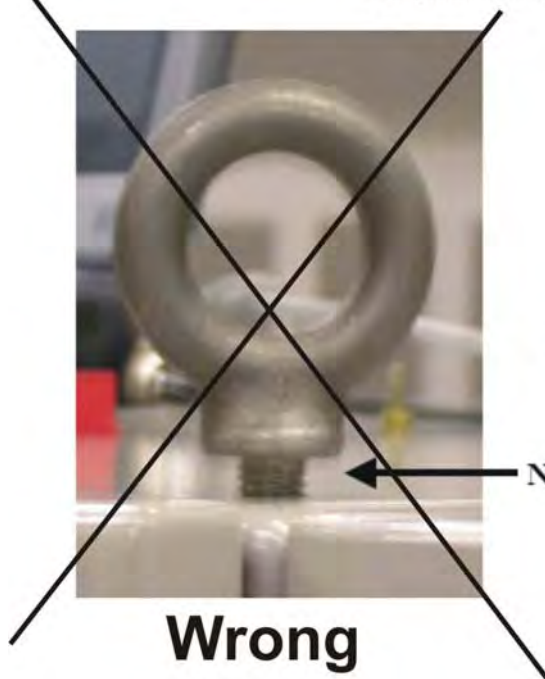

Fully Seated

Not Seated

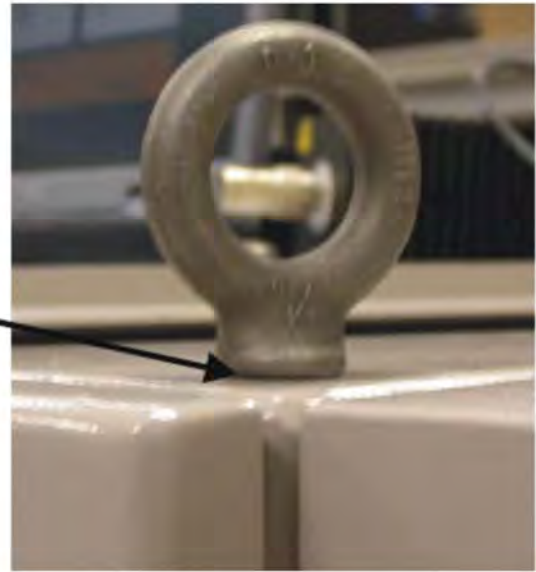

### Slings

Attach the slings to the boom line with a B connecting link or clevis. Attach the other ends of the slings to the lifting eyebolts with a B connecting link or clevis.

When a cabinet is being lifted with slings, it is unsafe to lift the cabinet when the lifting sling angle is less than 45 degrees to the top of the cabinet. At closer than 45 degrees, there is too much side stress on the lifting eyebolts. Use slings that are long enough to keep the lifting sling angle at greater than 45 degrees from the top of the cabinet.

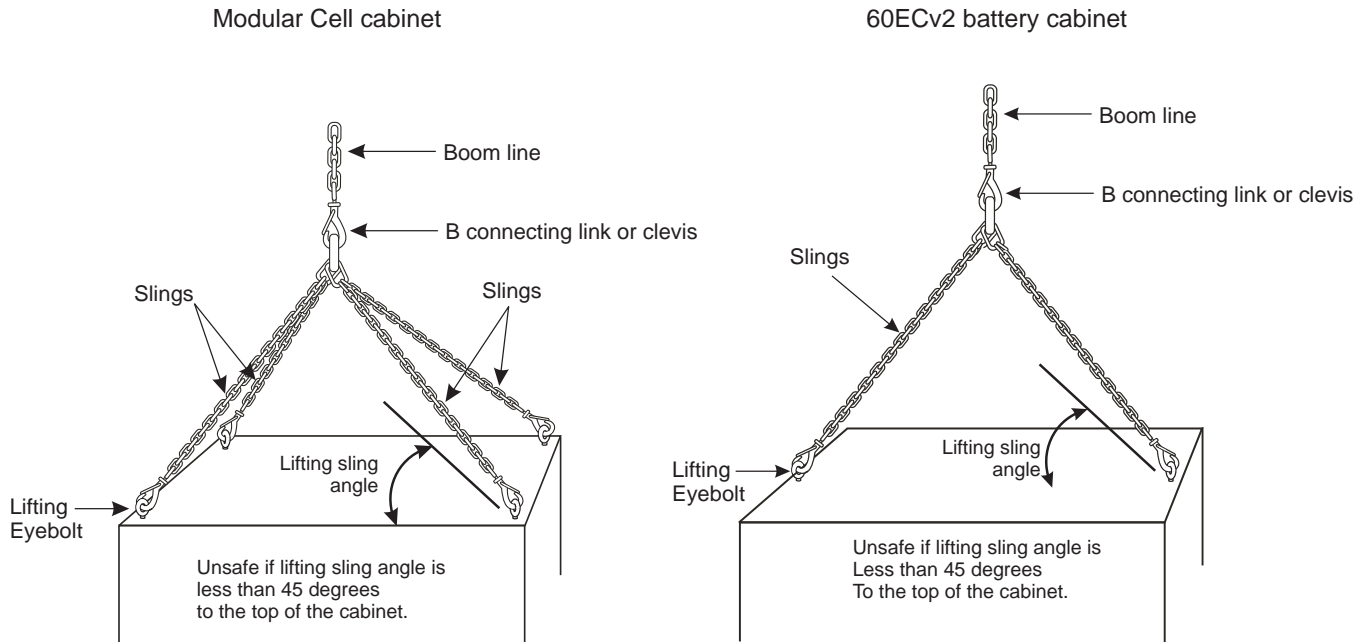

### Control the cabinet while it is being lifted

## NOTICE

### When Moving Cabinet

*When moving a cabinet, do not tilt the cabinet beyond 30 degrees from vertical. Do not stand under the cabinet.*

A rope tied to the pallet attached to the cabinet should be used to guide the cabinet while it is being lifted. The rope must be sufficiently long. As the cabinet is being lifted and transported, use the rope to guide the cabinet and prevent the cabinet from tilting or swinging.

Always lift cabinets carefully. Also, keep the boom line tight to prevent the cabinet from tipping while the cabinet is being moved. At the end of the lift, slowly place the cabinet on the ground.



# Appendix E: GPS antenna installation

## Overview

### Purpose

This appendix contains the information needed to install the GPS antenna.

### Contents

GPS antenna installation (general)	E-2
RF interference considerations	E-4
Lightning interference consideration	E-5
GPS antenna mount kit	E-9
GPS antenna mounting instructions	E-11
Active GPS antenna Standard Wave Ratio (SWR) test	E-15

---

## GPS antenna installation (general)

### Site selection

The GPS antenna installation site should be selected such that the maximum aggregate of all blockages above the 10 degree mask angle, such as buildings or mountains, does not exceed 25% of the surface area of a hemisphere around the GPS antenna. This blockage should not be in one contiguous quadrant of the hemisphere. Each contiguously blocked quadrant should be less than 12.5% of the sphere's surface area.

The following diagram shows the mask angle definition for the GPS antenna.

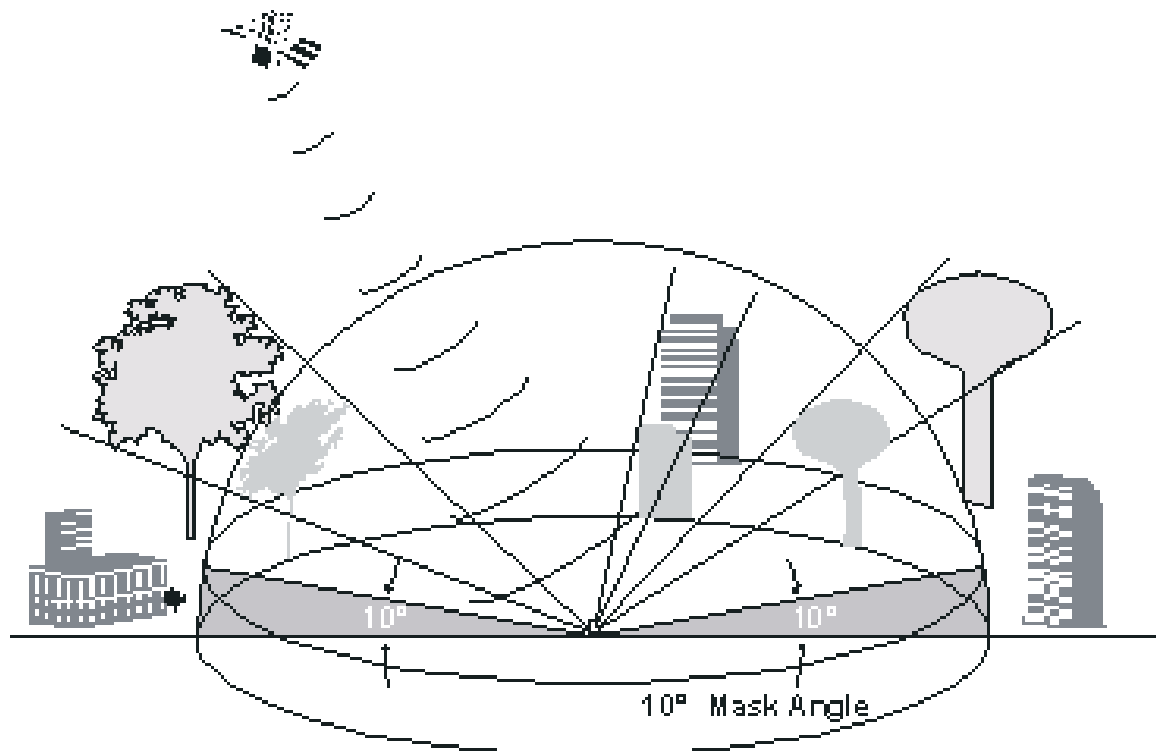

**Important!** Do not install the GPS antenna directly under structures that may accumulate or shed snow or ice.

It is desirable that the antenna has the clearest view to the south, east, and west in the northern hemisphere and to the north, east, and west in the southern hemisphere.

---

## Obstructions and interference

The following types of obstructions and possible sources of interference need to be considered:

- Hills, mountains, trees and surrounding plant life.
- Adjacent buildings or any large sky obstructing structures such as grain elevators, airplane hangers, bridges, overhead roadways, etc.
- Water towers or any close range large metal objects that could cause excessive sky obstruction.
- Any locations where birds or animals may easily nest or build on or around the antenna.
- Any collocated RF transmission antennas, TV stations, cable television cables, or arc-welding equipment.
- High-voltage lines will not cause interference with GPS signal reception.
- Self-supporting or guyed towers will generally not block the GPS signal.
- Trees do not totally block but rather degrade GPS reception, especially during periods of heavy rain or snow. Consider if increased summer plant life could also become a problem.
- If a GPS antenna is mounted to a monopole antenna mast, it must be mounted a minimum distance (D) from the monopole such that less than 12.5% of a contiguous surface area of a hemisphere around the antenna is blocked by the monopole. The GPS antenna must be spaced a minimum distance  $D = 1.61 \times R$  (where R is the radius of the monopole at the attachment point of the GPS antenna), from the outside surface of the monopole.

### Example:

Monopole radius (inches)  $R = 12$

$D = (1.61 \times 12)$

$D = 19.3$ " minimum

This example assumes, of course, that the monopole is the only obstruction to be considered, and constitutes a contiguous 12.5% blockage of the sky. This condition would constitute a contiguous blockage in one quadrant of the hemisphere.

---

## RF interference considerations

### RF interference considerations

The GPS antenna installation site should be chosen such that it is not in a direct radiation pattern of the cell site transmit antennas, and situated such that no other antennas, microwave transmit dishes, and other sources of RF radiation that could affect GPS reception are in close proximity. The GPS antenna should not be located within 10 feet horizontally and 10 feet vertically from any actively transmitting antenna.

---

## Lightning interference consideration

### Lightning considerations

Industry standard practices for lightning protection should be followed for GPS antenna installations. Several sources for such information are:

- *Grounding and Lightning Protection Guidelines for Alcatel-Lucent Network Wireless System Cell Sites*, 401-200-115
- *National Fire Protection Association (NFPA), NFPA 780, Standard for Installation of Lightning Protection Systems*
- *Poly Phaser Corporation “The Grounds”* for lightning protection and grounding solutions for communication sites.

The GPS antenna should be installed such that it is not the highest point in an installation (The GPS antenna must not be a lightning rod). The GPS antenna must be within the “protective cone” (see Figure on the following page) of any grounded structure such as an antenna tower or ancillary lightning rod. The “protective cone” is the area between the circumference of a circle with a 150 foot radius that tangentially touches the ground and the side or top of a grounded structure and the ground or structure.

### Protective cone installation

The following diagram shows the GPS antenna installed within the protective cone.

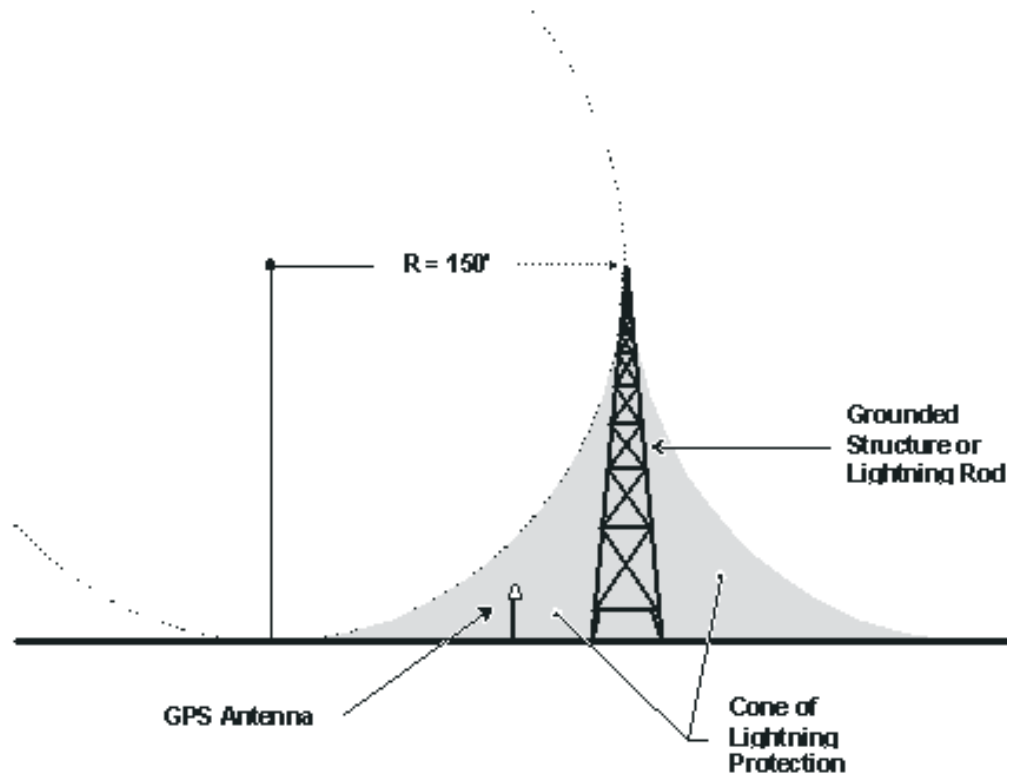

**Important!** The percentage of protection for the shaded zone is 96%.

### Lightning rod installation

If the GPS antenna is mounted to the side of an antenna tower above the 150 foot point, then horizontal lightning rods must be employed such that the antenna is within the area of a 150 foot sphere that touches both lightning rods, as shown in the following diagram.

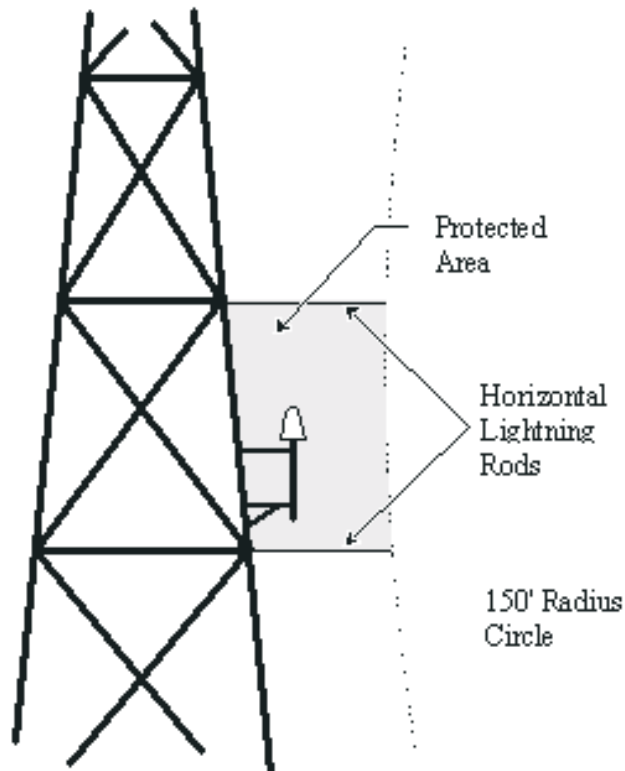

In addition, the GPS antenna coaxial cable shield shall be bonded at one point minimum near the equipment and/or hatch plate, provided the GPS antenna is installed in the cone of protection using short (less than 60 feet) coaxial cable.

**Important!** If the coaxial cable run along the tower is more than 60 feet, then the coaxial cable shield shall be grounded at multiple points near the antenna and equipment, at 100 foot intervals.

### Preventing Arc-over between structures and antenna

If the GPS antenna is mounted on a separate pole or structure of height (H) near an antenna tower or other grounded structure, and the distance (D) from the pole or structure to the tower or other grounded structure is less than the height of the pole divided by six ( $H/6$ ), then the pole or structure and the antenna tower must be bonded together eliminate possible arc over during a lightning strike.

#### Example:

If the pole is 50 feet tall, then  $D=8.3$  feet. ( $50/6 = 8.3$ ).

Refer to the following diagram for more detail.

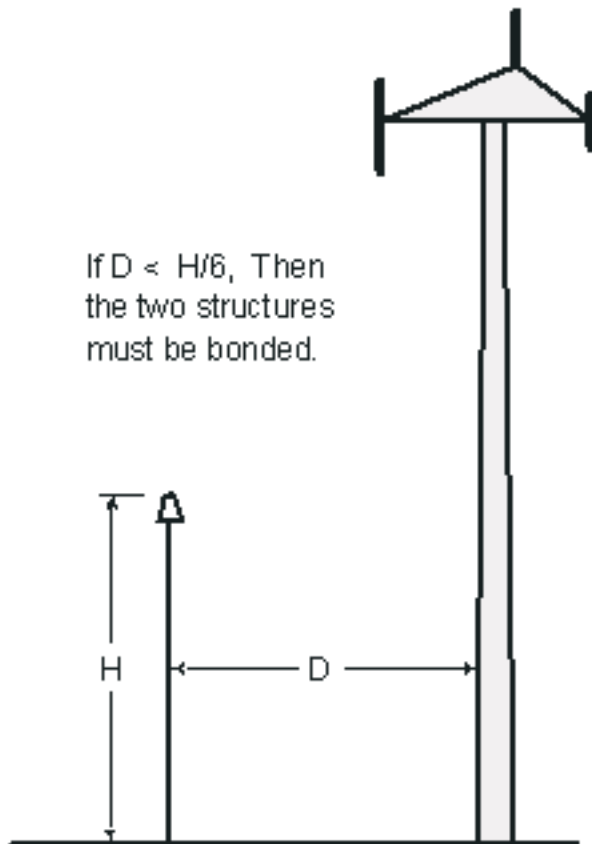



---

## GPS antenna mount kit

### General

GPS antenna mount kit are available from Andrews in several forms. The standard mount kit (denoted by the letters MS at the end of the part number) contains two separate kits that can be used together or separately in the installation of the mount. These separate kits are the Collar Bracket Mount Kit (part number 602214) and the L-Bracket Mount Kit (part number 602215). Alternatively, any one of these kits may be installed if the user requires. Remaining mount kit material may be retained for later use.

### GPS-QBW-26NMS

The GPS-QBW-26NMS is a self contained GPS antenna and mount kit. The kit includes a right hand circularly polarized antenna that incorporates a 26 dB high performance low noise amplifier as well as mounting hardware to attach the antenna to vertical pipe within a range of diameter.

### Pipe diameter

The L-Bracket Mount Kit will attach the GPS antenna onto a customer-supplied vertical pipe of diameter ranging between 3/4" to 1/12".

**Important!** Before installing any components ensure that the mounting pipe is the correct diameter and free of any components from previous installations.

This kit contains two mounting bracket types. The two brackets can be used together, as the standard mount kit, or separately as the L-Bracket Mount or the Collar Bracket Mount. The three mounting arrangements are covered in the following section.

## NOTICE

### Equipment Damage

*Twisting a cable can damage the cable.*

*DO NOT TWIST ANTENNA TO ATTACH OR REMOVE CABLE.*

### Bracket mount kits parts lists

The following table provides description of the mounting kit parts.

Collar Bracket Mount Kit (Part #602214)			
Item #	Part #	Quantity	Description
1a	602186	1	Collar

<b>Collar Bracket Mount Kit (Part #602214)</b>			
<b>Item #</b>	<b>Part #</b>	<b>Quantity</b>	<b>Description</b>
2	602190	1	Gasket
3a	602189	4	#10-32 UNF x 0.5" Captive Screw
4a	9978-78	2	0.25" - 20 UNC-3A x 1.0" Set Screw
5a	9903-7	1	Allen Wrench

<b>L- Bracket Mount Kit (Part #602215)</b>			
<b>Item #</b>	<b>Part #</b>	<b>Quantity</b>	<b>Description</b>
1b	602187-2	1	L - Bracket
2	602190	1	Gasket
3b	9845-2	4	#10-32 UNF x 0.312" Screw
4b	726042	2	Cleat
5b	9963-131	2	0.25" - 20 UNCx2.5" Hex Head Cap Screw
6b	9963-256	2	0.25" - 20 UNCx3.25" Hex Head Cap Screw
7b	9974-15	2	0.25" Lockwasher
8b	9999-57	2	0.25" - 20 Hex Nut

# GPS antenna mounting instructions

## Standard mount kit

Perform the following steps and refer to the following diagram to mount the GPS antenna. (See “[Bracket mount kits parts lists](#)” (p. E-9) on the previous page for part's description).

- 1 Attach L-Bracket, Item 1b, to customer-supplied vertical pipe using bolts (Items 5b or 6b to suit) and Items 4b, 7b and 8b. Locate in desired position.

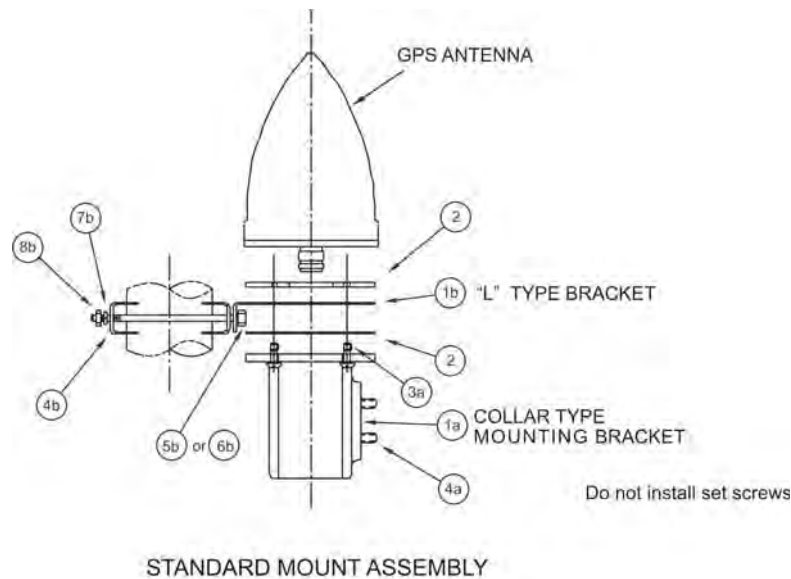

- 2 Tighten 0.25 inch hardware.
- 3 Insert the cable assembly, fitted with N male connector, through the Collar, Item 1a, and Gasket, Item 2. Install Captive Screws, Item 3a. Do not install set screws, Items 4a, for this configuration.
- 4 With Gasket, Item 2, on top of the L- Bracket, insert cable assembly through L-Bracket and Gasket. Attach the cable assembly to the GPS antenna and tighten the connector as required.

- 
- 
- 5 Slide the Collar and Gasket up to the antenna and attach to the antenna by pushing through the four Captive screws through the Gaskets and tighten them into the antenna base.
- 
- 6 Install weatherproofing that extends from directly underneath the flange on the collar bracket to at least 3 inches below the bottom of the collar measured on the cable assembly. The unused set screw holes will be covered.

**Important!** Weatherproofing is not provided with this kit.

END OF STEPS

---

### L-bracket mount kit

Perform the following steps and refer to the following diagram to mount the GPS antenna.

- 1 Attach L-Bracket, Item 1b, to customer-supplied vertical pipe using bolts (Items 5b or v 6b to suit) and Items 4b, 7b and 8b. Locate in desired position.

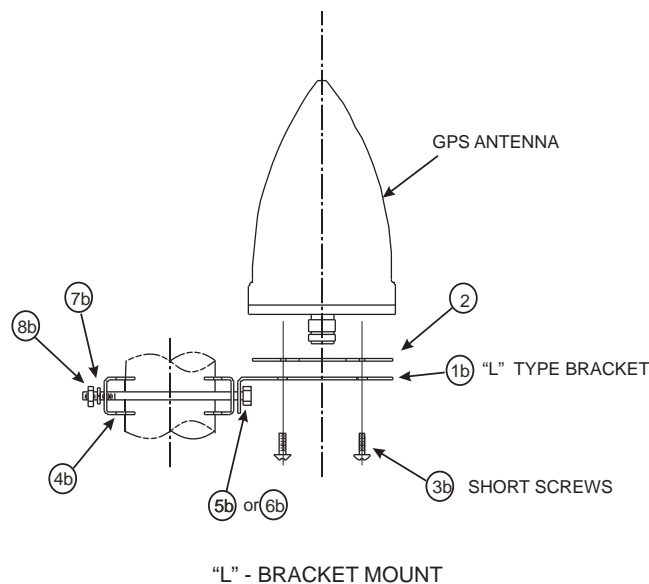

- 2 Tighten 0.25 inch hardware.

- 
- 
- 3 With a Gasket, Item 2, on top of the L-Bracket, insert cable assembly through L-Bracket and Gasket. Attach the cable assembly to the GPS antenna and tighten the connector as required.

---

  - 4 Insert the four short, Item 3b, screws through the L-Bracket and Gasket and attach antenna and tighten screws. Do not use the Captive Screws for this configuration.

---

  - 5 Install weatherproofing that extends at least 2 inch below the bottom of the connector on the cable assembly to directly underneath the base plate of the antenna.

**Important!** Weatherproofing is not provided with this kit.

END OF STEPS

---

### Collar mount kit

Perform the following steps and refer to the following diagram to mount the GPS antenna.

---

- 1 Install Captive Screws, Item 3a, and Set Screws, Item 4a, in Collar, Item 1a, then push

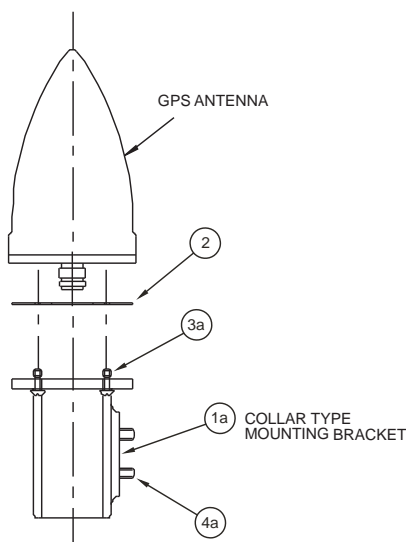

COLLAR MOUNT BRACKET

Captive Screws, Item 3a, through Gasket, Item 2, holes in order to retain Gasket.

- 
- 
- 2 Insert the cable assembly fitted with N male connector through the customer-supplied vertical mounting pipe, and Collar and Gasket assembly previously prepared.

---

  - 3 Attach cable assembly to the GPS antenna and tighten connector as required.

---

  - 4 Attach Collar and Gasket assembly to antenna and tighten Captive Screws, Item 3a, into antenna base.

---

  - 5 Slide assembly down so that the Collar slides over the mounting pipe. Tighten Set Screws, Item 4a.

---

  - 6 Install weatherproofing that extends from directly underneath the flange on the collar bracket to at least 3 inches below the bottom of the collar measured on the cable assembly.

**Important!** Weatherproofing is not provided with this kit.

END OF STEPS

---

## Active GPS antenna Standard Wave Ratio (SWR) test

### SWR test

The RF signals from the GPS satellites are extremely low-level microwave signals that must reach the RFTG with minimal distortion and loss. To verify the RF integrity of the complete antenna and cable system, a Standing Wave Ratio (SWR) or Distance-to-Fault (DTF) test should be performed.

Since the GPS antenna is an active device, a standard SWR or DTF test setup cannot be used. A Bias-T must be employed to inject +5 VDC into the RF line to power the antenna's Low Noise Amplifier (see Figure below).

**Important!** The antenna will meet its specified SWR only when powered in this way.

Calibrate the Wiltron as shown and per the manufacturer's instructions. Perform the SWR or DTF measurement as shown and per the manufacturer's instructions. Record the MAX SWR indicated and/or DTF data. If its MAX SWR is greater than 2.5, the fault must be repaired and the antenna and cable retested.

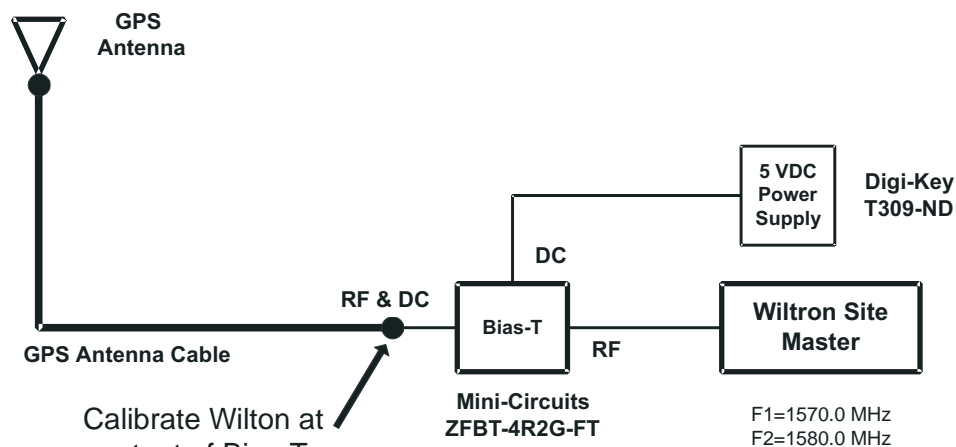

**Antenna SWR spec.**  
MAX SWR = 2.5 (7.4 dB return loss)

Digi-Key (800) 344-4539  
Mini-Circuits (800) 654-7949





# Appendix F: Power and Battery Engineering Rules for 9927 Distributed Base Station Outdoor Cabinet

## Overview

### Purpose

This appendix contains a copy of the document *Power & Battery Engineering Rules for Alcatel-Lucent CDMA Modular Cell 4.0B*, ER\_0102\_0004\_PWR, which is the primary source for power requirements and battery backup information for the 9927 Distributed Base Station Outdoor Cabinet.

### Contents

<a href="#">Engineering Rules Document</a>	F-2
--	-----

---

# Engineering Rules Document

## Description

The remaining pages of this appendix are the pages of the *Power & Battery Engineering Rules for Alcatel-Lucent CDMA Modular Cell 4.0B*, ER\_0102\_0004\_PWR.

# Appendix G: Product conformance statements

## Overview

### Purpose

This section presents the product conformance statements that apply to the 9228 Base Station cabinet.

In regions such as North America and the European Union, the statements that are required are determined primarily by national or multinational regulations. However, in some regions, contract terms determine which statements are required.

The presence of the statement indicates that the product does comply with that statement wherever it is required to do so.

### Contents

<a href="#">Canada</a>	<a href="#">G-2</a>
<a href="#">European Union</a>	<a href="#">G-5</a>
<a href="#">United States</a>	<a href="#">G-10</a>

---

# Canada

## Introduction

The statements that follow are the product conformance statements that apply to the 9228 Base Station sMacro cabinet when deployed in Canada.

## Industry Canada

### **ICES-003: Interference-Causing Equipment Standard Digital Apparatus**

This Class A digital apparatus complies with Canadian ICES-003.

Cet appareil numérique de la classe A est conforme à la norme NMB-003 du Canada.

### **IC CS-03: Specification for Terminal Equipment, Terminal Systems, Network Protection Devices, Connection Arrangements and Hearing Aids Compatibility**

This product meets the applicable Industry Canada technical specifications.

## RF approval

### **RSS-132: Cellular Telephones Employing New Technologies Operating in the Bands 824-849 MHz and 869-894 MHz**

The term “IC” before the certification/registration number only signifies that the Industry Canada technical specifications were met.

### **RSS-133: PCS Radio Standards Specifications**

The term “IC” before the certification/registration number only signifies that the Industry Canada technical specifications were met.

## Product safety conformance

The 9228 Base Station cabinet is Safety Certified ITE by Underwriters Laboratories (UL) and UL Canada.

This Certification is marked on the equipment main nameplate label. Should the local Authority Having Jurisdiction (AHJ) require prior or additional verification of this Certification, a Product Certificate of Compliance can be obtained from the specific Certification Body by the Business/Product Unit Applicant for the product or by contacting:

Technical Support Services, within Canada: +1 630 224 4672, prompt 2

Any modifications to this equipment are not permitted without review and official written authorization from the specific Certification Body. Unauthorized changes may violate the Product Safety Certification. Modifications or changes authorized by official CN/CNN are assumed to have received prior approval from this Lab.

---

## Antenna exposure

Antenna installations for the 9228 Base Station cabinet shall be performed in accordance with all applicable manufacturer's recommendations, and national laws and regulations. To ensure correct antenna installation, the antenna installer shall perform all necessary calculations and/or field measurements to evaluate compliance with applicable national laws or regulations regarding exposure to electromagnetic fields. The supplier of radio equipment, the supplier of antenna equipment and the integrator and builder of the site must provide sufficient information so that the limits of the exclusion zones can be determined. Any changes to the antenna or other equipment in the transmit path may require re-evaluation of the exposures to electromagnetic fields.

## Human exposure

Pursuant to Health Canada Safety Code 6, Limits of Human Exposure to Radio frequency Electromagnetic Fields in the Frequency Range from 3 kHz to 300 GHz, all installations must be evaluated against the Maximum Exposure Limits as described in Chapter 2, Health Canada 99-EHD-237.

## Optical transmitters

Alcatel-Lucent declares that 9228 Base Station cabinet complies with the International Electrotechnical Commission (IEC) standards IEC 60825-1 Edition 2.0 (2007) and IEC 60825-2 Edition 3.1 (2007). It is a Class I/1 laser optical fiber communication systems "product" under the IEC classifications.

This product is designed to ensure that personnel operating the product are not endangered by laser radiation during normal operation and fault conditions. This product does not present a risk of eye injury because it is fully enclosed and does not contain embedded lasers greater than Class I/1 unless otherwise noted.



*Use of controls or adjustments or performance of procedures other than those specified herein may result in hazardous laser radiation exposure.*

*Do not view directly into the laser beam with optical instruments such as a fiber microscope because viewing of laser emission in excess of Class 1 limits significantly increases the risk of eye damage.*

*Never look into the end of an exposed fiber or an open connector as long as the optical source is switched on.*

*Ensure that the optical source is switched off before disconnecting optical fiber connectors.*

---

## Packaging collection and recovery requirements

Countries, states, localities, or other jurisdictions may require that systems be established for the return and/or collection of packaging waste from the consumer, or other end user, or from the waste stream. Additionally, reuse, recovery, and/or recycling targets for the return and/or collection of the packaging waste may be established.

For more information regarding collection and recovery of packaging and packaging waste within specific jurisdictions, please contact the Alcatel-Lucent Services - Environmental Health and Safety organization. For installations not performed by Alcatel-Lucent Technologies, please contact the Alcatel-Lucent Customer Support Center at:

Technical Support Services, within Canada: +1 630 224 4672, prompt 2

---

## European Union

### Introduction

The statements that follow are the product conformance statements that apply to the 9228 Base Station cabinet bearing the CE Marking and when deployed in the European Union.

### Declaration of Conformity for radio and telecommunication terminal equipment under the scope of Directive 1999/5/EC

Hereby, Alcatel-Lucent declares that the equipment documented in this publication is in compliance with the essential requirements and other relevant provisions of Directive 1999/5/EC.

The technical documentation as required by the Conformity Assessment procedure is kept at the Alcatel-Lucent location which is responsible for this product. For more information please contact your local Alcatel-Lucent Customer Service Organization.

### CE marking

This product has been CE-marked in accordance with the following European Directive:

- Radio and Telecommunication Terminal Equipment (R&TTE) 1999/5/EC

### EMC and radio spectrum compliance for the 850 MHz product

The equipment complies with the following EMC and radio spectrum specifications:

- EN 300 339 V1.1.1 (1998-06)
- ETSI EN 301 489-1 V1.6.1 (2005-09)
- ETSI EN 301 489-26 V2.3.1 (2005-07)
- ETSI EN 301 908-1 V2.2.1 (2003-10)
- Code of Federal Regulations FCC part 24(E)
- IS 3GPP2 - C.S0010-B

### Product safety conformance

The equipment complies with the following product safety specifications:

- EN 60950-1:2001
- EN 60215:1989

### Telecommunications Standards

The equipment complies with the following telecommunication specifications:

- Technical Basis Regulation TBR 13

---

## Antenna exposure

Antenna installations for the 9228 Base Station cabinet shall be performed in accordance with all applicable manufacturer's recommendations, and national laws and regulations. To ensure correct antenna installation, the antenna installer shall perform all necessary calculations and/or field measurements to evaluate compliance with applicable national laws or regulations regarding exposure to electromagnetic fields. The supplier of radio equipment, the supplier of antenna equipment and the integrator and builder of the site must provide sufficient information so that the limits of the exclusion zones can be determined. Any changes to the antenna or other equipment in the transmit path may require reevaluation of the exposures to electromagnetic fields.

Pursuant to

- European Council Recommendation 1999/519/EC “On the limitation of exposure of the general public to electromagnetic fields” dated 12 July 1999 and
- ICNIRP (International Commission on Non-Ionising Radiation Protection) “Guidelines for limiting exposure to time-varying electric, magnetic, and electromagnetic fields”,

all installations must be evaluated against the Reference Levels, and if necessary exclusion zones for public and installation workers defined.

The following information on Alcatel-Lucent supplied equipment is available from customer representatives:

- Output power and antenna characteristic, if the product is equipped with an integral antenna.
- A detailed description of at least one typical normal configuration, including antenna system (feeders, connectors, combiners, antennas etc.), if the product is intended to be used with external antennas.
- Limit distances for general public and occupational exposure. If the product is intended for use with external antennas, limit distances shall be given for the given typical system configurations.
- Information how to specify exposure levels and limit distances for any optional system configuration not specified in detail.
- Information on how to install the equipment/system or the external antennas in order to ensure that the separation between the radiating antenna and general public are exceeding the maximum allowed distances.

Information on the methodology used for the determination of RF safety compliance distances and exclusion zones, and the results of the compliance evaluation shall be available for inspection by officials of the governing authorities.



---

## Optical transmitters

Alcatel-Lucent declares that 9228 Base Station cabinet complies with the CENELEC standards EN 60825-1 Edition 1994 and its amendment 1 (2002) and amendment 2 (2001) and EN 60825-2 Edition 2004. It is a Class I/1 laser optical fiber communication systems “product” under the IEC classifications.

This product is designed to ensure that personnel operating the product are not endangered by laser radiation during normal operation and fault conditions. This product does not present a risk of eye injury because it is fully enclosed and does not contain embedded lasers greater than Class I/1 unless otherwise noted.



*Use of controls or adjustments or performance of procedures other than those specified herein may result in hazardous laser radiation exposure.*

*Do not view directly into the laser beam with optical instruments such as a fiber microscope because viewing of laser emission in excess of Class 1 limits significantly increases the risk of eye damage.*

*Never look into the end of an exposed fiber or an open connector as long as the optical source is switched on.*

*Ensure that the optical source is switched off before disconnecting optical fiber connectors.*

## Packaging collection and recovery requirements

Countries, states, localities, or other jurisdictions may require that systems be established for the return and/or collection of packaging waste from the consumer, or other end user, or from the waste stream. Additionally, reuse, recovery, and/or recycling targets for the return and/or collection of the packaging waste may be established.

For more information regarding collection and recovery of packaging and packaging waste within specific jurisdictions, please contact the Alcatel-Lucent Services - Environmental Health and Safety organization. For installations not performed by Alcatel-Lucent Technologies, please contact the Alcatel-Lucent Customer Support Center at:

Technical Support Services, from all other countries: +1 630 224 4672, prompt 2

---

## Recycling / take-back / disposal of product

Electronic products and batteries bearing or referencing the symbols shown below when put on the market within the European Union, shall be collected and treated at the end of their useful life, in compliance with applicable European Union and local legislation. They shall not be disposed of as part of unsorted municipal waste. Due to materials that may be contained in the product and batteries, such as heavy metals, the environment and human health may be negatively impacted as a result of inappropriate disposal.

Note 1: For electronic products put on the market in the European Union, a solid bar under the crossed-out wheeled bin indicates that the product was put on the market after 13 August 2005.



Note 2: For batteries put on the market in the European Union, a chemical symbol Hg (mercury), Cd (cadmium), or Pb (lead), or a combination of those symbols, beneath the cross-out wheeled bin indicates that the battery contains the corresponding heavy metals.



Moreover, in compliance with legal requirements and contractual agreements, where applicable, Alcatel-Lucent will offer to provide for the collection and treatment of Alcatel-Lucent products bearing the logo at the end of their useful life, or products displaced by Alcatel-Lucent equipment offers.

---

For information regarding take-back, recycling, or disposal of equipment by Alcatel-Lucent or for equipment take-back requests, visit the Alcatel-Lucent Take-Back web page ([http://www.alcatel-lucent.com/product\\_takeback](http://www.alcatel-lucent.com/product_takeback)), or contact Alcatel-Lucent Takeback Support at [takeback@alcatel-lucent.com](mailto:takeback@alcatel-lucent.com). For technical information on product treatment, consult the Alcatel-Lucent Recycling Information web page ([http://www.alcatel-lucent.com/product\\_recycling](http://www.alcatel-lucent.com/product_recycling))

### Material content compliance

European Union (EU) Directive 2002/95/EC, “Restriction of the use of certain Hazardous Substances” (RoHS), restricts the use of lead, mercury, cadmium, hexavalent chromium, and certain flame retardants in electrical and electronic equipment. This Directive applies to electrical and electronic products placed on the EU market after 1 July 2006, with various exemptions, including an exemption for lead solder in network infrastructure equipment. Alcatel-Lucent products shipped to the EU after 1 July 2006 comply with the EU RoHS Directive.

---

# United States

## Introduction

The statements that follow are the product conformance statements that apply to the 9228 Base Station cabinet when deployed in the United States.

## Federal Communications Commission

**Important!** Changes or modifications not expressly approved by Alcatel-Lucent, Inc. could void the user's authority to operate the equipment.

This device complies with Part 15 of the FCC Rules. Operation is subject to the following two conditions: (1) This device may not cause harmful interference, and (2) this device must accept any interference received, including interference that may cause undesired operation.

### FCC Part 15 Class A (as marketed)

**Important!** This equipment has been tested and found to comply with the limits for a Class A digital device, pursuant to Part 15 of the FCC Rules. These limits are designed to provide reasonable protections against harmful interference when the equipment is operated in a commercial environment. This equipment generates, uses, and can radiate radio frequency energy and, if not installed and used in accordance with the instruction manual, may cause harmful interference to radio communications. Operation of this equipment in a residential area is likely to cause harmful interference, in which case the user will be required to correct the interference at the user's expense.

### FCC Part 15 Class B (as marketed)

**Important!** This equipment has been tested and found to comply with the limits for a Class B digital device, pursuant to Part 15 of the FCC Rules. These limits are designed to provide reasonable protection against harmful interference in a residential installation. This equipment generates, uses, and can radiate radio frequency energy and, if not installed and used in accordance with the instructions, may cause harmful interference to radio communications. However, there is no guarantee that interference will not occur in a particular installation. If this equipment does cause harmful interference to radio or television reception, which can be determined by turning the equipment off and on, the user is encouraged to try to correct the interference by one or more of the following measures:

- Reorient or relocate the receiving antenna
- Increase the separation between the equipment and receiver
- Connect the equipment into an outlet on a circuit different from that to which the receiver is connected
- Consult the dealer or an experienced radio/TV technician for help.

---

**FCC Part 68**

This equipment complies with Part 68 of the FCC rules and the requirements adopted by the ACTA. On the cabinet assembly of this equipment is a label that contains, among other information, a product identifier in the format of AAAEQ##TXXXX. If requested, this number must be provided to the telephone company.

- FIC 04DU9-1SN
- SOC 6.0N

The T1 network interface on this equipment is hard wired to a punch down block , which meets the FCC specifications.

If this equipment 9228 Base Station cabinet causes harm to the telephone network, the telephone company will notify you in advance that temporary discontinuance of service may be required. However, if advance notice is not practical, the telephone company will notify the customer as soon as possible. Also, you will be advised of your right to file a complaint with the FCC if you believe it is necessary.

The telephone company may make changes in its facilities, equipment, operations, or procedures that could affect the operation of the equipment. If this happens, the telephone company will provide advance notice in order for you to make necessary modifications to maintain uninterrupted service.

FCC regulations prohibit the connection of customer-provided equipment to central office implemented systems. Connection to party lines is subject to tariffs; users should contact their state public utility commission, public service commission, or corporation commission for information.

If the equipment is causing harm to the telephone network, the telephone company may request that you disconnect the equipment until the problem is resolved.

If trouble is experienced with this equipment repair or warranty information may be obtained by contacting:

Technical Support Services, within the United States: +1 630 224 4762, prompt 2

**RF approval**

This equipment complies with Part 2, Subpart J - Equipment Authorization Procedures, of the FCC Rules.

This device complies with Part 22 - Public Mobile Services, Subpart H - Cellular Radiotelephone Services

This equipment complies with Part 24 - Personal Communications Services, Subpart E - Broadband PCS.

This equipment complies with Part 27 - Miscellaneous Wireless Communications Services

---

**FDA/IEC optical transmitter product compliance**

Alcatel-Lucent declares that 9927 Distributed Base Station cabinet complies with the Food and Drug Administration's Center for Devices and Radiological Health (FDA/CDRH) regulations 21 CFR 1040.10 and 1040.11. It is a Class I/1 laser optical fiber communication systems "product" under the FDA.

This Product is designed to ensure that personnel operating the product are not endangered by laser radiation during normal operation and fault conditions. This product does not present a risk of eye injury because it is fully enclosed and does not contain embedded lasers greater than Class I/1 unless otherwise noted.



*Use of controls or adjustments or performance of procedures other than those specified herein may result in hazardous laser radiation exposure.*

*Do not view directly into the laser beam with optical instruments such as a fiber microscope because viewing of laser emission in excess of Class 1 limits significantly increases the risk of eye damage.*

*Never look into the end of an exposed fiber or an open connector as long as the optical source is switched on.*

*Ensure that the optical source is switched off before disconnecting optical fiber connectors.*

**Product safety conformance**

The 9228 Base Station cabinet is Safety Certified ITE by Underwriters Laboratory (UL) and UL Canada.

This Certification is marked on the equipment main nameplate label. Should the local Authority Having Jurisdiction (AHJ) require prior or additional verification of this Certification, a Product Certificate of Compliance can be obtained from the specific Certification Body by the Business/Product Unit Applicant for the product or by contacting:

Technical Support Services, within the United States: +1 630 224 4762, prompt 2

Any modifications to this equipment are not permitted without review and official written authorization from the specific Certification Body. Unauthorized changes may violate the Product Safety Certification. Modifications or changes authorized by official CN/CNN are assumed to have received prior approval from this Lab.

---

## Antenna exposure

Antenna installations for the 9927 Distributed Base Station cabinet shall be performed in accordance with all applicable manufacturer's recommendations, and national laws and regulations. To ensure correct antenna installation, the antenna installer shall perform all necessary calculations and/or field measurements to evaluate compliance with applicable national laws or regulations regarding exposure to electromagnetic fields. The supplier of radio equipment, the supplier of antenna equipment and the integrator and builder of the site must provide sufficient information so that the limits of the exclusion zones can be determined. Any changes to the antenna or other equipment in the transmit path may require reevaluation of the exposures to electromagnetic fields.

Pursuant to 47 CFR Part 1, Subpart I, subject to the provisions of section 1.1307, all installations must be evaluated for requirements contained in Table 1, "Limits for maximum permissible exposure," in section 1.1310.

## Packaging collection and recovery requirements

Countries, states, localities, or other jurisdictions may require that systems be established for the return and/or collection of packaging waste from the consumer, or other end user, or from the waste stream. Additionally, reuse, recovery, and/or recycling targets for the return and/or collection of the packaging waste may be established.

For more information regarding collection and recovery of packaging and packaging waste within specific jurisdictions, please contact the Alcatel-Lucent Services - Environmental Health and Safety organization. For installations not performed by Alcatel-Lucent Technologies, please contact the Alcatel-Lucent Customer Support Center at:

Technical Support Services, within the United States: +1 630 224 4762, prompt 2

## Material content compliance

The following notification applies to Alcatel-Lucent products distributed for sale, resale or use.

This product, part, or both may include a lithium-manganese dioxide battery, which contains very small amounts of a perchlorate substance. Special handling may apply.

For California:

Perchlorate Material - special handling may apply.

See <http://www.dtsc.ca.gov/hazardouswaste/perchlorate/>