

# **EXHIBIT 3**

## **Installation and Operating Instructions** **SECTION 2.1033 (b)(3)**

---

# Introducing the WaveACCESS NET 2400 System

# 1

---

## **THIS IS AN INCOMPLETE DRAFT.**

This chapter introduces the **WaveACCESS NET** product family, including its main features and benefits. In addition, workflows for installing the **CU232** and the remote unit are provided.

### **About this chapter:**

**Introducing the WaveACCESS NET Product Family**, page 1-2, provides an overview of the **WaveACCESS NET** product family.

**Features and Benefits**, page 1-6, describes the numerous features and benefits that can enhance working environments using wireless systems.

**WaveACCESS NET Ruggedized Unit**, page 1-7, describes the additional features and benefits provided by the ruggedized **WaveACCESS NET 2400** units, for outdoor installation.

**Technical Specifications**, page 1-8, describes the technical specifications of the **WaveACCESS NET** units.

**CU232 Installation Workflow**, page 1-11, provides a workflow for installing the **WaveACCESS NET CU232**.

**Remote Unit Installation Workflow**, page 1-12, provides a workflow for installing the **WaveACCESS NET MDR232** and **SDR232**.

## Introducing the WaveACCESS NET Product Family

---

The **WaveACCESS NET** system is a radio-based, high-capacity, high bit rate, low-cost packet switched wireless system that operates in the 2.4 Ghz ISM unlicensed band to provide point-to-multipoint wireless Internet access. It is designed to provide communications for several hundred users simultaneously accessing the Internet or intranet.

**WaveACCESS NET** employs Frequency Hopping Spread-Spectrum (FHSS) technology at data rates of 3.2 and 1.6 Mbps. The fully digital FHSS radio provides protection against interference and enables operation of collocated systems, thereby increasing overall data throughput. **WaveACCESS NET** has been optimized for IP traffic and provides high-speed networking at distances of several miles.

The **WaveACCESS NET** system consists of a central site known as the base station, and up to several hundred remote sites. The base station is where the system links to a backbone, for example, telephony, satellite, wireless, or digital cable data transmissions. The **WaveACCESS NET CU232** sits at the base station.

The remote sites are the user locations, where remote **WaveACCESS NET xDR232** units act as LAN adapters.

The **WaveACCESS NET** system is comprised of the following:

- **WaveACCESS NET CU232:** A wireless point-to-multipoint central unit that can support up to 60 remote units at a data rate of 3.2 Mbps each. Using unique **RFStacker™** technology, up to ten **WaveACCESS NET CU232** units can be collocated in a single site, creating a cell of up to 600 remote units at a data rate of up to 25 Mbps. A remote unit does not necessarily indicate a single user (for example, an **MDR232** can support an entire LAN). Therefore, the actual number of users the **WaveACCESS NET CU232** is able to support is considerably higher than the number of remote units.



---

**Figure 1-1** WaveACCESS NET CU232

- **WaveACCESS NET SDR232:** A standalone wireless LAN adapter (remote unit), including a built-in antenna, designed to connect to any computer's Ethernet adapter card and allow fast linking of any workstation to the Internet or Intranet. This allows the user access to the full bandwidth, without having to share the capacity with multiple users on a network.



---

**Figure 1-2 WaveACCESS NET xDR232**

- **WaveACCESS NET MDR232:** A multidrop remote unit, including a built-in antenna, that provides a bridging function and enables a complete LAN to be connected over a wireless network. This unit has particular application for a small office environment, in which a single **MDR232** would enable all the computers to access the Internet.

A high-level view of the system architecture is shown in Figure 1-3.

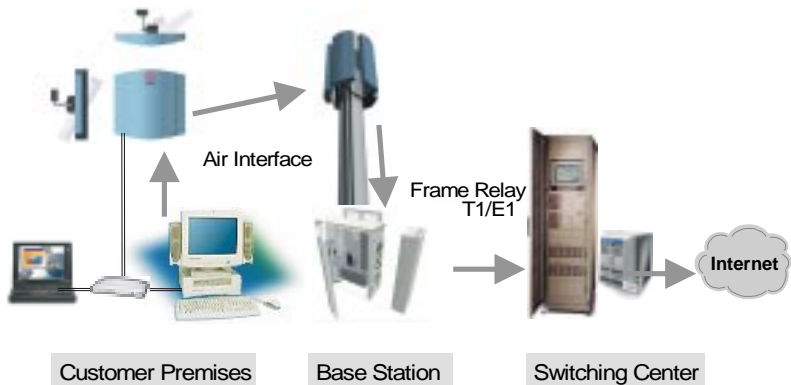

**Figure 1-3 High Level System Architecture**

### Sectorization of the Central Site

**WaveACCESS NET CU232** units are typically installed in business or residential areas which do not have well-defined boundaries. It is not always possible to place the base station, with the central units and antennas, in the optimal location. Therefore, the **WaveACCESS NET** system provides the ability to sectorize the base station by using multiple **CU232** units, each of which covers a sector of the total area to be covered.

This allows an increase in cell range from approximately two miles, for an omnidirectional 8dBi antenna, to approximately seven miles for a 20dBi panel antenna.

If you have many users in one area, you may have more than one **CU232** covering the same area to provide optimal throughput for all the users.

### Features and Benefits

---

The **WaveACCESS NET** wireless point-to-multipoint system has numerous features and benefits that can enhance working environments where wireless systems are essential:

- Simple deployment, installation and operation.
- Digital Frequency Hopping Spread Spectrum (FHSS) technology that can support many overlapping links and deliver resilience to interference and exceptional data integrity.
- Operates in the 2.4 GHz ISM band, making it available for unlicensed use in most parts of the world.
- No configuration requirements, just plug it in and it works.
- Management and configuration utilities enable you to quickly make advanced configuration changes.
- Fully digital packet radio with advanced QPSK and 16QAM modulation.
- Advanced bandwidth-enhancing ADEQ™ technology.
- Optional dual antenna diversity.
- SNMP managed, MIB II compliant with proprietary MIB.
- Long range, high speed point-to-multipoint links.
- Bandwidth management on a per-link basis.
- Improved security features for ISPs.

### WaveACCESS NET Ruggedized Unit

---

The **WaveACCESS NET 2400** units are fully ruggedized and suitable for outdoor installation, in weather conditions of -40°C to 55°C.

An internal antenna is embedded in each unit, although there is also an option to use an external antenna for wider coverage. A single flexible cable is used to transmit data and supply the unit's power. The **WaveACCESS NET 2400** product now includes a power/data adapter that connects to the AC power supply directly and provides an Ethernet connection.

While the **WaveACCESS NET 2400** system is fully compatible with the previous **WaveACCESS NET** version, it provides enhanced functionality, as follows:

- Firstly, the fact that the unit is ruggedized and has an embedded antenna precludes the need for a long RF cable connecting the indoor unit to its external antenna (with its inevitable losses). Thus, the signal quality and the effective ranges are improved.

Increased maximum range enables ISPs to accommodate more users with a higher data rate in that cell and at the same level of service. This benefits both ISPs and users of the system, as users with a low data rate use more bandwidth when transmitting the same data, than users with a higher data rate.

- Secondly, the **WaveACCESS NET 2400** units custom cable connects to both the AC power supply and the Ethernet via a single box, as opposed to the two boxes (one each for power supply and Ethernet) in the previous version. The cable itself is thin and easy to manipulate and enables the unit to be placed up to 100 meters from the power supply.
- Thirdly, the **WaveACCESS NET 2400** is easier to install.



You have the option to set up an external antenna for wider coverage than is provided by the internal directional antenna. When an external antenna is used, it is connected directly to the radio output.

## Technical Specifications

---

The following technical specifications for the **WaveACCESS NET** units are for reference purposes only. The actual product's performance and compliance with local regulations may vary from country to country. Lucent Technologies reserves the right to improve the products from time to time and actual specifications may vary.

**Table 1-1 Technical Specifications of the WaveACCESS NET Unit**

| <b>MODELS: WaveACCESS NET CU232, MDR232, and SDR232</b> |   |  |
|---|---|--|
| <b>Description</b>                                      | <b>CU232</b><br>2.4 GHz Wireless point-to-multipoint Ethernet Bridge Central Unit | <b>MDR232 AND SDR232</b><br>2.4 GHz Wireless point-to-multipoint Ethernet Bridge |
| <b>Wireless Medium</b>                                  | Frequency Hopping Spread Spectrum (FHSS)  |  |
| <b>Operating Frequency</b>                              | 2.402 - 2.480 GHz   |  |

**Table 1-2 WaveACCESS NET Unit Performance Specifications**

| <b>PERFORMANCE</b>            |  |  |
|-------------------------------|--|--|
| <b>Data Rate</b>              | <b>CU232</b><br>3.2 Mbps, fallback to 1.6 Mbps                   | <b>MDR232 AND SDR232</b><br>3.2 Mbps, fallback to 1.6 Mbps                   |
| <b>No. of Ind. Channels</b>   | 79   |  |
| <b>Cell Throughput</b>        | <b>CU232</b><br>Up to 2.2 Mbps @ 3.2 Mbps<br>1.2 Mbps @ 1.6 Mbps | <b>MDR232 AND SDR232</b><br>Up to 2.2 Mbps @ 3.2 Mbps<br>1.2 Mbps @ 1.6 Mbps |
| <b>Throughput Enhancement</b> | ADEQ™ Adaptive Equalization                                      |  |
| <b>TECHNICAL DATA</b>         |  |  |
| <b>Radio Technology</b>       | FHSS using QPSK and QAM modulation                               |  |
| <b>Antenna Connector</b>      | Reversed polarity SMA  |  |
| <b>Antenna Diversity</b>      | Option for 2 separate antennas                                   |  |
| <b>Output Power</b>           | 50 mW  |  |
| <b>Wired LAN Connections</b>  | 10Base-T (RJ-45)   |  |
| <b>Wired LAN Protocol</b>     | IEEE 802.3 CSMA / CD   |  |

**Table 1-3 WaveACCESS NET Unit Configuration and Management Specifications**

| <b>CONFIGURATION AND MANAGEMENT</b> |  |  |
|-------------------------------------|--|--|
| Configuration                       | Via any wired Ethernet LAN station, SNMP, TFTP, Bootp, or via RS-232 9-pin female D-type connector.          |  |
| SNMP Management                     | MIB II, Bridge MIB and proprietary MIB   |  |
| LED Indicators                      | <b>CU232</b><br>Power, System Status, Wired Ethernet Link, Wired Ethernet Transmit, Wireless Transmit, Sync. | <b>MDR232 AND SDR232</b><br>Power, System Status, Wired Ethernet Link, Wired Ethernet Transmit, Wireless Transmit, Sync. |

**Table 1-4 WaveACCESS NET Unit Environmental Specifications**

| <b>ENVIRONMENTAL</b>         |  |
|------------------------------|--|
| <b>Dimensions</b>            | 8 x 1.5 x 4.25 in<br>(20.5 x 3.8 x 10.8 cm)      |
| <b>Temperature Range</b>     | 32°F to 105°F (0°C to 40°C)                      |
| <b>Humidity</b>              | 0% to 95% non-condensing                         |
| <b>External Power Supply</b> | 110 VAC or 220 VAC,<br>50/60 Hz, 6.2 VDC @ 1.5 A |

## CU232 Installation Workflow

---

The following workflow illustrates the procedure that may be followed when installing the **CU232**.

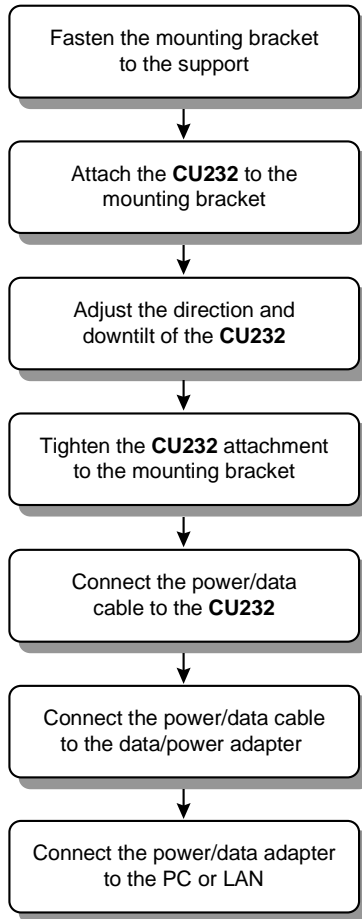

---

**Figure 1-4** CU232 Installation Workflow

**Remote Unit Installation Workflow**

---

The following workflow describes the procedure that may be followed when installing the **xDR232**.

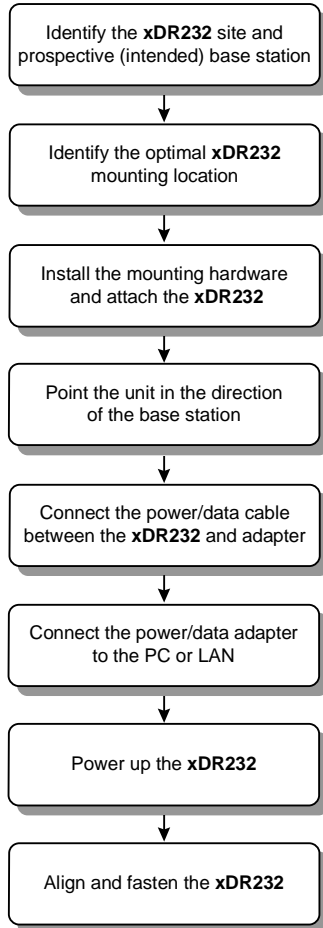

---

**Figure 1-5 xDR232 Installation Workflow**

---

# WaveACCESS NET 2400 Base Station Site Preparation

# 2

---

**THIS IS AN INCOMPLETE DRAFT.**

This chapter describes the requirements and specifications that must be satisfied when preparing a site for the installation of the **WaveACCESS NET CU232** units (base station).

**About this chapter:**

**Clearances and Space Requirements**, page 2-2, describes the clearances and space requirements for installing the **CU232**.

**Tower Pipe Installation**, page 2-6, describes

**Electrical Power Requirements**, page 2-7, provides guidelines for the installation of electrical power to the base station.

**Grounding and Lightning Protection Bonding Requirements**, page 2-8, describes the grounding and lightning protection requirements for a **WaveACCESS NET** base station.

## Clearances and Space Requirements

---

The intended installation area must include enough space to accommodate the **CU232**. Figure 2-1 shows the space required for the **CU232** installation.

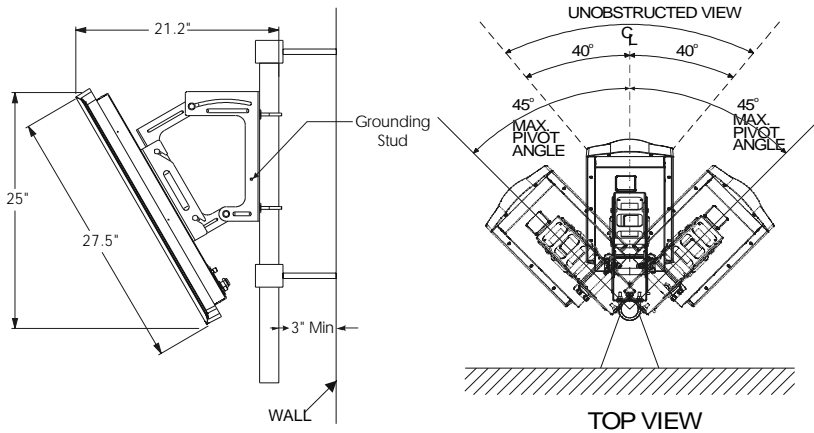

---

Figure 2-1 Space Required for CU232

## Dimensions and Weight of the CU232

---

The dimensions and weight of the **CU232** are displayed in Table 2-1.

**Table 2-1 Dimensions and Weight of the CU232 As-Installed**

| <b>Equipment</b> | <b>Width</b>   | <b>Depth</b>  | <b>Height</b>  | <b>Weight</b>  |
|------------------|----------------|---------------|----------------|----------------|
| CU232            | 12 in<br>30 cm | 5 in<br>13 cm | 30 in<br>76 cm | 13 lbs<br>6 kg |

### **Minimum Space Required Between Multiple CU232s**

---

When multiple **CU232s** are installed, the space required between each **CU232** must be:

- Horizontal space of 31 centimeters (12 inches).
- Vertical space of 1 meter (3 feet).



Figure 2-2 shows the spacing requirements for multiple **CU232s**.

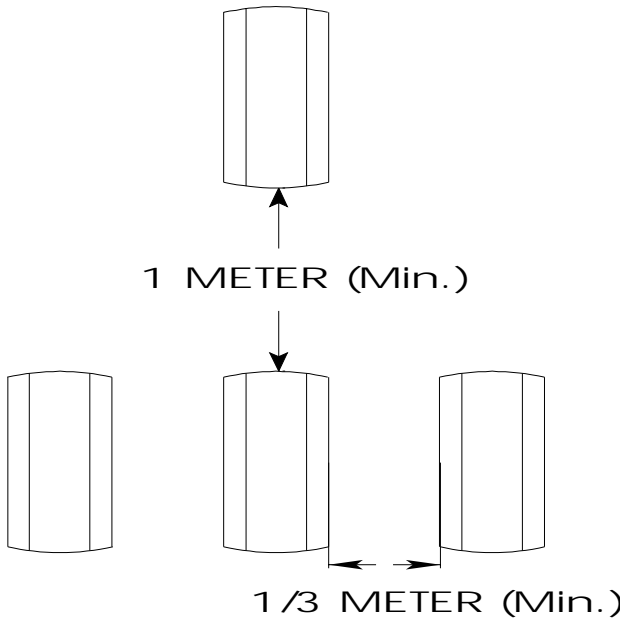

---

**Figure 2-2 Multiple CU232 Spacing Requirements**

### **CU232 Environmental Requirements**

---

The environmental requirements must be within the limits specified in Table 2-2, in order for the **CU232** to operate properly.

**Table 2-2 CU232 Environmental Requirements**

| <b>Environmental Conditions</b> |                        |
|---------------------------------|------------------------|
| Minimum Ambient Temperature     | - 40.0 °C (- 40 °F)    |
| Maximum Ambient Temperature     | + 46.0 °C (+ 114.8 °F) |
| Minimum Relative Humidity       | 10%                    |
| Maximum Relative Humidity       | 100%                   |

## Tower Pipe Installation

---

It is recommended that towers have a wind rating of 100mph with 5, 10, or 15 **CU232s**. Each **CU232** will experience 80 kg (175 lbs) of wind load at 100mph w/wind factor normal to **CU232**. The tower should be able to support 1, 2, or 3 sets of **CU232s**.

The installation height of the antenna must be approximately 15 m above the surrounding average building height, or as specified by the field RF engineer.

The pipes to which the **CU232s** will be attached should be mounted either on a tower, or on the sides of a building near the roofline, at a height specified by the field RF engineer.

When tower installation is performed, the pipe should be installed around the tower with an angular separation of 72 degrees. In certain instances, it may not be possible to install the support pipe at 72 degree intervals. The ability to swing the **CU232** from side to side over an arc of approximately 45 degrees is required. One of the support pipes should be mounted on the tower so that it faces North. A subsequent pipe can then be installed at 72 degree increments from the reference Northward facing pipe.

When performing the installation of five **CU232s** on a building, the support pipes should be located on a common wall. The other three **CU232s** can be installed on the other three sides of the building. The clearance requirements should comply with Figure 2-1.

The minimum distance between any **CU232** support pipe and other wireless telecommunication equipment should be two meters.

## **Electrical Power Requirements**

---

This section provides guidelines for the installation of AC or 48VDC electrical power to the base station, as follows:

- **General Requirements**, page 2-7.
- **CU232 Power Requirements**, page 2-7.

### **General Requirements**

---

All the AC wiring and over-current protection must be provided in accordance with the National Electric Code (NFPA-70) and local electrical codes. An appropriate earth-ground connection is required before the commercial AC service can be connected. The base station AC input power is single phase, nominal 120/208 or 120/240 Vrms, 50/60 Hz. Nominal voltage is defined as 120 Vrms between line(s) to ground, and 208 Vrms or 240 Vrms line to line.

### **CU232 Power Requirements**

---

Each **CU232** requires 24-48VDC, 15 Watts, which is supplied by the power/data adapter.

## Grounding and Lightning Protection Bonding Requirements

---

This section provides information on grounding and lightning protection requirements for a **WaveACCESS NET** base station, as follows:

- **General Requirements**, page 2-7.
- **Lightning Protection**, page 2-10.

### General Requirements

---

The **WaveACCESS NET** base stations are susceptible to lightning surges due to their association with towers and antennas. Therefore, it is imperative that all base station components be properly grounded, providing a low impedance path to earth. The grounding conductors must be as straight and short as possible and should not have any sharp bends or loops.

The **CU232** cable shield must be bonded at the top and bottom of the vertical run, and where it comes near the equipment. The tower or metallic support of the antenna must also be bonded to the grounding system. In addition, the surge protection device must be bonded to a nearby ground bus bar that is connected directly to the grounding electrode system.

All metallic objects within 2 meters (6 feet) of the grounded equipment must be bonded to the grounding system.

All base station equipment must be bonded to a grounding electrode system, for example, buried ring ground, copper clad rod, electrolytic rods, metallic water pipe, and so on.

The minimum requirement for buried ground conductors is #2 AWG bare, solid, tinned copper wire. Exterior ground conductors must be either solid, bare, tinned copper or stranded, insulated (for sunlight resistance) copper cable. The interior ground cable must be stranded copper with green insulation type THAWN or equivalent.

All grounding system material, namely, cable, connectors, buses, and so on, must be made of high quality materials that are resistant to deterioration and that require little or no maintenance.

An exothermic weld is recommended for grounding connections, where practical. All below-grade connections must be exothermically welded. In addition, compression type, long barrel, two-hole (0.75" center) lugs or double crimp "C" Taps are also acceptable. The metal contacts to which connections are made must have a bare bright finish, and be coated with an anti-oxidation material.

Refer to Lucent Technologies 401-200-115, *Grounding and Lightning Protection Guidelines for Wireless System Base Stations*, for detailed requirements regarding grounding and lightning protection bonding.



### **WARNING:**

*The equipment warranty can be voided if the guidelines detailed in the National Electric Code (NFPA 70), Standard for Installation of Lightning Protection System (NFPA 780, 1995 edition), Lucent Technologies 401-200-115, and Lucent Technologies Equipment Drawings referred to in this document are not followed.*

Refer to Appendix C for a checklist of the verification of the grounding requirements that can be performed.

## Lightning Protection

---

The preferred method of reducing the risk of lightning strikes is avoidance. **CU232s** and remote units must be mounted within the 45° lightning protection cones, as shown in Figure 2-3. The 45° lightning protection cone also applies to tower-mounted units.

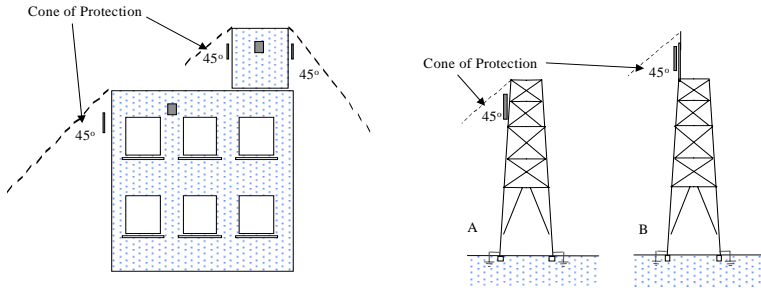

---

**Figure 2-3** Lightning Protection Cone

---

## Installing the CU232

# 3

---

**THIS IS AN INCOMPLETE DRAFT.**

This chapter describes the installation procedures of the **WaveACCESS NET CU232**.

**About this chapter:**

**Installation Requirements for the CU232**, page 3-2 describes the physical installation requirements of the **WaveACCESS NET CU232**.

**Mounting and Tilting the CU232**, page 3-5 describes the procedure for mounting and tilting the **WaveACCESS NET CU232**.

**Connecting the Power/Data Cable**, page 3-8 describes the procedure for connecting the power/data cable to the **WaveACCESS NET CU232**.

**Connecting the Power/Data Cable to the Adapter**, page 3-9 describes the procedure for connecting the power/data cable to the power/data adapter.

**Connecting to the PC or LAN**, page 3-9 describes connecting the **CU232** to your computer or network by installing the power/data cable between the **CU232** and the power/data adapter.

**Powering Up the CU232**, page 3-9 describes the procedure for powering up the **CU232**.



### Installation Requirements for the CU232

---

The qualifications required for an installer are similar to those required to install standard office telecommunications equipment. Installers should be familiar with local construction techniques, requirements, and regulations associated with the installation of cabling and brackets in an urban or suburban environment, and must be able to run simple diagnostic procedures.

This section describes the physical installation requirements of the **WaveACCESS NET CU232**, as follows:

- **Installation Items Provided by Lucent**, page 3-2.
- **Additional Installation Items Required**, page 3-3.

#### Installation Items Provided by Lucent

---

The following items are included in the Lucent Technologies installation kit:

- **WaveACCESS NET CU232** wireless central unit.
- **CU232** mounting bracket.
- One power/data adapter complete with a 5-foot (1.5m) cord.
- A software diskette.
- One power/data cable of 10m, 30m, or 100m.
- This **WaveACCESS NET 2400** *Installation Guide*.
- A CD-ROM containing documentation.

When an additional antenna is required, you will also receive a second package that includes the **WaveACCESS NET** antenna kit that was ordered with the system.



**NOTE:**

If any of these items are incomplete or missing, you might not be able to install the **WaveACCESS NET CU232**. In this case please contact your nearest Technical Support Center. Refer to Chapter 8 "Technical Support" for more information.

The following additional items are provided by Lucent Technologies for the installation team:

- Cable tester (comcode #).
- Power/data cable (comcode 408158830).
- **CU232** electrical power tester (comcode #).

### **Additional Installation Items Required**

---

The following list describes the items that are not provided by Lucent Technologies, but are required for installation.

- Bolts, mounting hardware
- Drill and drill bits
- Grounding braid
- Nut drivers
- Ladder
- Pliers
- Long nose pliers
- Screwdrivers
- Safety glasses
- Cable ties

- **Specialized wire stripping tools:**
  - Precision wire stripper  
OK Industries, model ST-550  
Details from [www.okindustries.com](http://www.okindustries.com)  
Available from: Newark Electronics, Tel. 800-463-9275
  - Cable jacket cutter  
Ideal Cyclops, model 45-514
  - Data cable cutter  
Ideal Cyclops, model 45-074  
Details from [www.idealindustries.com](http://www.idealindustries.com)
  - Miniature needle nose pliers
  - Phillips No. 1 screwdriver
  - Flat screwdriver with 2.3 to 2.5 mm blade  
Available from: Allied Electronics, Tel. 800-433-5700
- Wrenches
- Torque wrench (40 in-lb capacity)
- Multimeter
- Cutters
- Downtilt meter
- Utility knife
- Tape measure
- Pipe, U-bolts, and so on.
- Connections to Ethernet
- Compass or other directional equipment

### Mounting and Tilting the CU232

The **WaveACCESS NET CU232** should be mounted in front of a wall or structure, to minimize the interference of other signals from behind the unit.

The **CU232** mounting bracket can be fastened in the following ways:

- To a 2 m (6 ft.) long, 5 cm (2 in) diameter “schedule 40” pole, using two of the tension belts provided along with the mating nuts and split lock washers (preferred technique).
- To a pole that is rigidly fastened to a tower (optional technique).

The location of the **CU232** bracket supports will be provided by the site preparation team, in compliance with the site preparation guidelines, as described in Chapter 2.

Prior to installation, record or scan the barcode that includes the serial number and MAC addresses of the **CU232s**, and identify the azimuth (horizontal) and elevation (downtilt) in which each **CU232** will be pointing when installed. Provide the orientation information to the RF network planner.

### To mount the CU232:

1. Fasten the **CU232** mounting bracket to the pole with the two straps. You can improve the access to the fastening hardware by opening the **CU232** mounting to the "unfolded" configuration, as shown in Figure 3-1. The mounting bracket should face in the general direction of the remote unit.

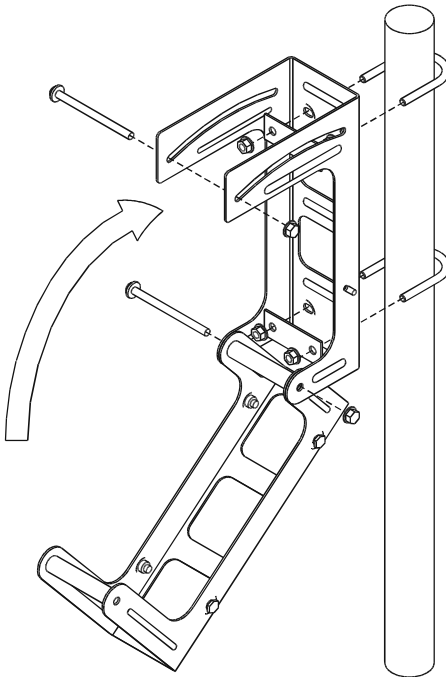

---

**Figure 3-1 CU232 Mounting Bracket Fastened to Pole**

2. Mount and partially fasten the **CU232** to the bracket.



**NOTE:**

Ensure that you perform steps 3 and 4 before tightening the straps completely.

## Installing the CU232

---

3. Adjust the direction of the **CU232** by rotating it to the required azimuth (horizontal) orientation.
4. Using the downtilt meter adjust the downtilt of the **CU232** according to the RF planning requirements for the site.
5. Tighten the fastening belts of the **CU232** when it is correctly oriented.
6. Tighten the pivot bolts.

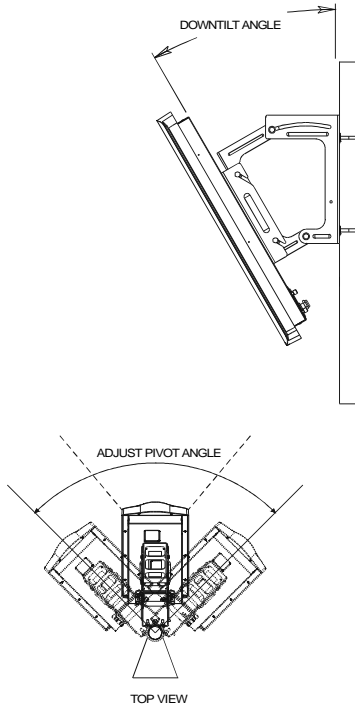

---

**Figure 3-2 CU232 Tilt Angle**

### Connecting the Power/Data Cable

When you have completed mounting and tilting the **CU232**, it must be connected to the power/data cable.



**NOTE:**

It is recommended that you use the Lucent cable tester (comcode #) with the adapter cable (comcode 848340337) to verify the power/data cable integrity before plugging the cable into the **CU232**. Before you make the connections to the **CU232**, check that the wiring is correct.

**To connect the power/data cable:**

1. Connect the power/data cable to the water-tight connector on the cover plate. Turn the connector until it clicks.
2. Label the power/data cable according to the **CU232** to which it is connected, namely, **CU232#1**, **CU232#2**, and so on.
3. It is recommended that the power/data cable be clamped at regular intervals. Ensure that you leave extra cable at the **CU232** in case further maintenance and adjustments are required.

## Connecting the Power/Data Cable to the Adapter

This step involves connecting the **CU232** to your computer or network by installing the power/data cable between the **CU232** and the power/data adapter. Figure 3-3 provides a guide to wiring the power/data adapter.

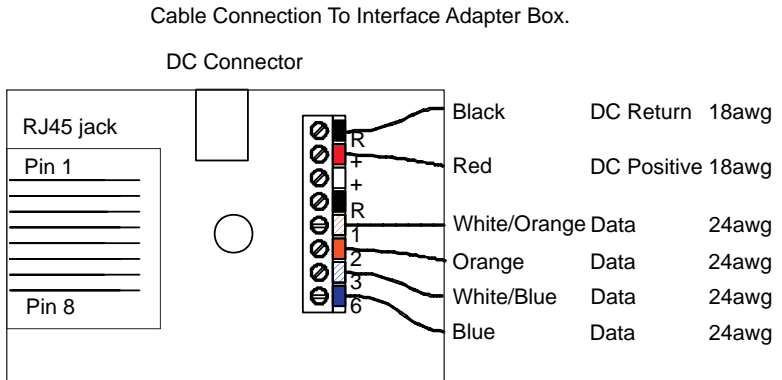

**Figure 3-3** Cable Connection to the Power/Data Adapter



### CAUTION:

*The **CU232** must be grounded to prevent an atmospheric static charge from accumulating on the chassis and to reduce unpredictable static discharges that may result in serious damage to the subscriber's equipment (Ethernet hubs, PCs, LANs, and so on), as well as to the remote unit.*





### **CAUTION:**

*When installing **CU232s**, follow the guidelines detailed in the National Electric Code (NFPA 70), Standard for Installation of Lightning Protection System (NFPA 780, 1995 edition), Lucent Technologies 401-200-115, and the Lucent Technologies Equipment Drawings referred to in this document.*

### **To connect the power/data cable to the power/data adapter:**

1. Using the Cyclops cable jacket cutter (Model 45-514), strip the outer sheath 22 to 28 mm and remove the sheath, foil shield and the bare wire.
2. Untwist the pairs of wires. Set the strip length of the precision wire stripper (OK Industries Model ST-550) to 6mm and set the dial to 10. Strip the red and black wires.
3. Reset the precision wire stripper dial to 5 and strip the remaining 4 wires.
4. Push all 6 levers down.
5. Holding the power/data adapter in one hand, use the needle nose pliers to locate the red and black wires in the correct color-coded terminals of the terminal block and push the levers back to secure the wires.
6. Locate the orange pair of wires and tighten them. Locate and tighten the blue pair of wires.
7. Push the cable towards the terminal block so that the cable clamp grips onto the outer sheath. Pull the clamp tight with the needle nose pliers.
8. Check that the clamp is secure by slowly pulling the cable.
9. Locate the printed wiring board in the adapter. Put on the cover and tighten the screw with a No. 1 Phillips screwdriver.

## Installing the CU232

---

Figure 3-4 provides a guide to connecting the power/data adapter.

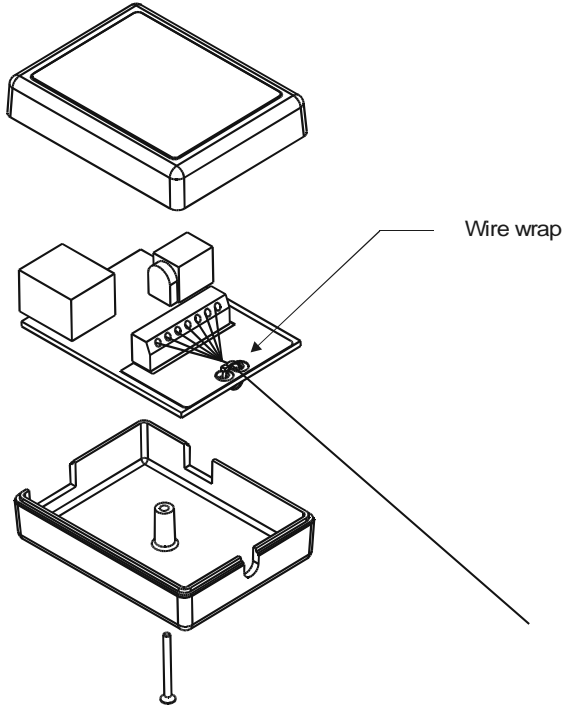

---

**Figure 3-4 Connecting the Power/Data Adapter**

### Connecting to the PC or LAN

---

This step involves connecting the **CU232** to your PC or network using an Ethernet cable.

1. Connect the Ethernet cable from the power/data adapter to a PC using a "cross-over" cable format for single user installations, as shown in Figure 3-5.

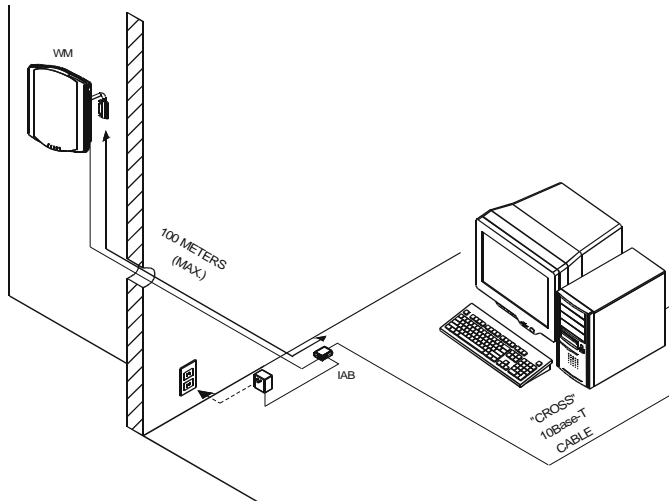

---

**Figure 3-5 Single User Installation Connecting the Ethernet Cable**

Alternatively, use a "straight-through" cable format when connecting the power/data adapter to a LAN hub for multiple user installations, as shown in Figure 3-6.

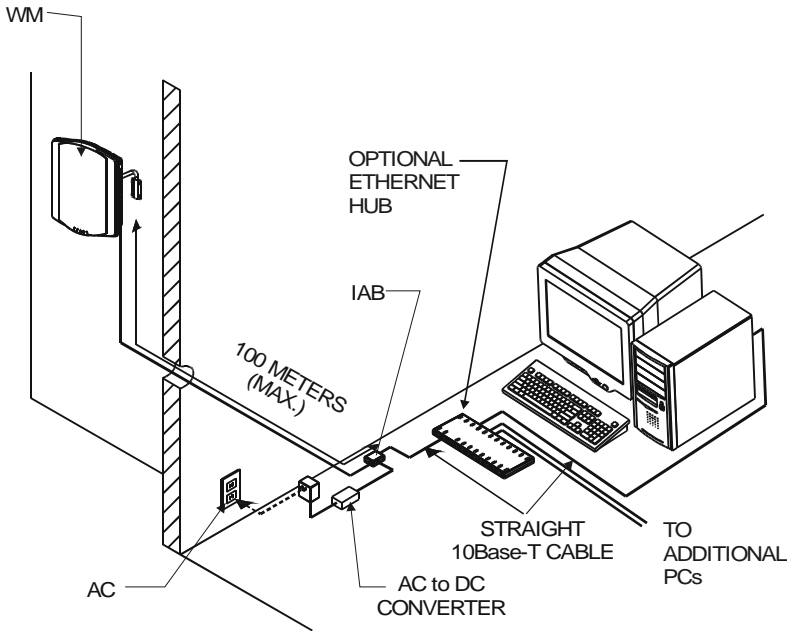

**Figure 3-6 Multiple User Installation Connecting the Ethernet Cable**

### Powering Up the CU232

---

After they have been connected, the **WaveACCESS NET CU232** units can be powered up.

#### To power up the CU232:

- Plug the power supply into an AC outlet. The power supply is doubly insulated and therefore a ground outlet is not required.



#### NOTE:

When you are turning off the power to the **CU232**, wait at least 10 seconds for the capacitors in the **CU232** to discharge before reapplying power. If the capacitors do not discharge, the **CU232** will not initialize properly.

### Lightening Protection

---

For information, refer to Appendix A “Lightening Protection”.

---

# WaveACCESS NET 2400 Remote Unit Site Preparation

# 4

---

**THIS IS AN INCOMPLETE DRAFT.**

This chapter describes the requirements and specifications that must be satisfied when preparing a site for the installation of the **WaveACCESS NET** remote units (**MDR232** and **SDR232**).

**About this chapter:**

**Overview**, page 4-2, describes the **WaveACCESS NET** remote units.

**Horizontal Surface Mounting**, page 4-3, describes mounting the **WaveACCESS NET xDR232** on a horizontal surface.

**Vertical Surface Mounting**, page 4-6, describes mounting the **WaveACCESS NET xDR232** on a vertical surface.

**Remote Unit (xDR232) Environmental Requirements**, page 4-8, describes the environmental requirements of the **WaveACCESS NET** remote units.

**Remote Unit (xDR232) Wiring**, page 4-9, describes the wiring requirements of the **WaveACCESS NET** remote units.

## Overview

---

The remote units (**xDR232s**) are the user locations, where remote **WaveACCESS NET** units act as LAN adapters. There are two types of remote units, each of which includes a built-in antenna and interfaces to end user PCs:

- **MDR232:** A multidrop remote that provides a bridging function and enables a complete LAN to be connected over a wireless network. This unit has a particular application for a small office environment, in which a single **MDR232** would enable all the computers to access the Internet.
- **SDR232:** A single drop remote that enables single user access to the Internet. This allows the user access to the full bandwidth, without having to share the capacity with multiple users on a network.

The **xDR232** provides a reliable air interface capability to the subscriber. It connects to the end user via a 10Base-T physical interface supporting the Ethernet protocol. The **xDR232** is physically attached to the outside of a home or office. It measures 34 cm x 31 cm x 13 cm and weighs 4 kgs.

The **xDR232** package consists of the following:

- **xDR232** unit.
- Power/data adapter.
- Data and power cables.
- Power supply.
- Mounting brackets (vertical/horizontal).

## **Horizontal Surface Mounting**

---

This section describes mounting the **WaveACCESS NET MDR232** and **SDR232** on a horizontal surface, as follows:

- **Physical Considerations**, page 4-3.
- **Clearances**, page 4-4.
- **Dimensions and Weight of the xDR232**, page 4-5.
- **Cabling and Facilities Requirements (Customer-Supplied)**, page 4-5.

### **Physical Considerations**

---

When preparing the remote site for horizontal surface mounting, the structure needs to conform with the basic space and environmental requirements. The specified area must include the space required by the **xDR232**, as shown in Figure 4-1.



## Clearances

---

A sufficient amount of space must be provided so that the **xDR232** can swing up and down, and side to side. The minimum spacing requirements for the **xDR232** is a height of 43 cm (17 in) and a width of 31 cm (12 in).

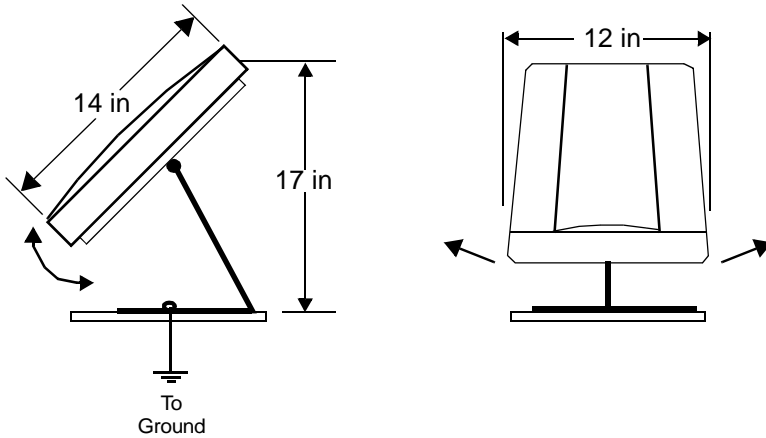

---

**Figure 4-1** Horizontal Surface Mounting Space Requirements for the **xDR232**

### **Dimensions and Weight of the xDR232**

---

The dimensions and weight of the **xDR232** are displayed in Table 4-1.

**Table 4-1 xDR232 As-Installed Dimensions and Weight**

| <b>Width</b> | <b>Depth</b> | <b>Height</b> | <b>Weight</b> |
|--------------|--------------|---------------|---------------|
| 12 in        | 4 in         | 17 in         | 8 lbs         |
| 31 cm        | 9 cm         | 43 cm         | 4 kg          |

### **Cabling and Facilities Requirements (Customer-Supplied)**

---

A typical horizontal surface mounting site should have all the required grounding completed before beginning the installation of the **xDR232**.

## Vertical Surface Mounting

---

This section describes mounting the **WaveACCESS NET xDR232** on a vertical surface, as follows:

- **Physical Considerations**, page 4-6.
- **Clearances**, page 4-6.

### Physical Considerations

---

When you are preparing the **xDR232** site for vertical surface mounting, the structure needs to conform with the basic space and environmental requirements. The specified area must include the space required by the **xDR232**, and the mounting pipe (optional).

Although the mounting pipe is optional, it is highly recommended that one is used.

When selecting the site for the **xDR232**, keep in mind that the maximum cable length allowed from the **xDR232** to the PC/Ethernet Hub connector is 100 m (300 ft.), as shown in Figure 4-3.

### Clearances

---

The spacing requirements for the **xDR232** are critical. It is essential that enough clearance is provided so that the **xDR232** can swing up and down, and side to side. A minimum clearance of 33 cm (13 in) is recommended for the **xDR232** to swing up and down, and 81 cm (32 in) to swing side to side.

When mounting the **xDR232** with the optional pipe, there is an additional spacing requirement of 15 cm (6 in) so that the **xDR232** can swing in all directions.

The vertical surface mounting space requirements for the **xDR232** are shown in Figure 4-2.

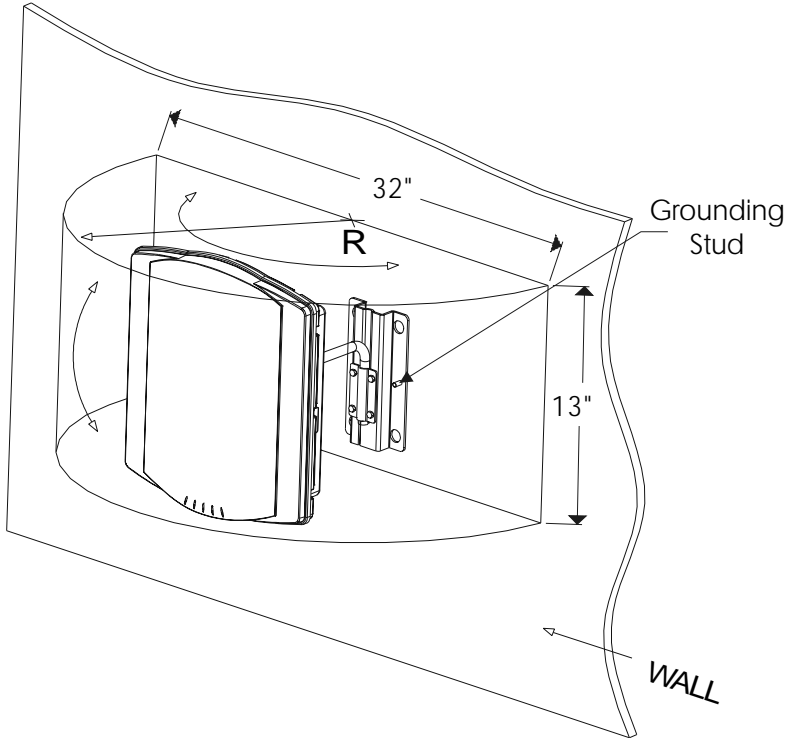

---

**Figure 4-2 Vertical Surface Mounting Space Requirements**

## Remote Unit (xDR232) Environmental Requirements

---

This section describes the **WaveACCESS NET xDR232** environmental requirements.

The environmental requirements must be within the limits specified in Table 4-2 in order for the **xDR232** to operate properly.

**Table 4-2 Vertical Surface Mounting Environmental Requirements**

| Environmental Conditions    |                    |
|-----------------------------|--------------------|
| Minimum Ambient Temperature | - 40 °C<br>- 40 °F |
| Maximum Ambient Temperature | 46 °C<br>115 °F    |
| Minimum Relative Humidity   | 10%                |
| Maximum Relative Humidity   | 100%               |

## Remote Unit (xDR232) Wiring

This section describes the **WaveACCESS NET MDR232** and **SDR232** wiring requirements, as follows:

- **Cable Entry**, page 4-9.
- **Site Grounding and Bonding Requirements**, page 4-10.

### Cable Entry

A point of entry is required to connect the **xDR232** to the power/data adapter, which is always located indoors, as shown in Figure 4-3.

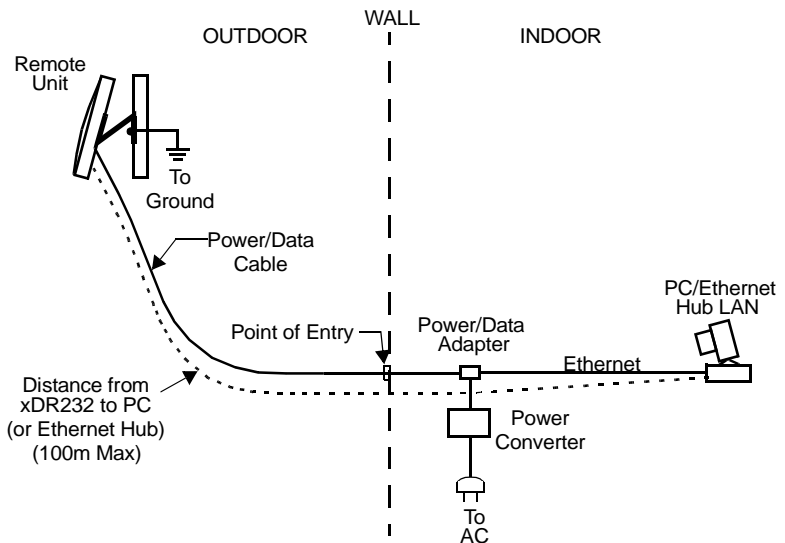

Figure 4-3 xDR232 Wiring

### Site Grounding and Bonding Requirements

The grounding system must provide a low-impedance path from the **xDR232** to the earth in order to protect personnel from electric shocks and to ensure the safe, reliable operation of the equipment. For more information, refer to *Chapter 2, WaveACCESS NET 2400 Base Station Site Preparation*.



#### **WARNING:**

*The equipment warranty can be voided if the guidelines detailed in the National Electric Code (NFPA 70), Standard for Installation of Lightning Protection System (NFPA 780, 1995 edition), Lucent Technologies 401-200-115, and Lucent Technologies Equipment Drawings referred to in this document are not followed.*

---

# Installing the Remote Units

# 5

---

**THIS IS AN INCOMPLETE DRAFT.**

This chapter describes the installation procedures of the **WaveACCESS NET MDR232** and **SDR232**.

**About this chapter:**

**Overview**, page 5-2, provides a brief overview and installation workflow for the remote units.

**Safety Precautions**, page 5-3, lists the safety precautions for the NET service provider.

**Installation Requirements for the xDR232**, page 5-4, describes the physical installation requirements for the **WaveACCESS NET xDR232**.

**Installing the xDR232**, page 5-7, describes how to install the **xDR232**.

**Troubleshooting**, page 5-25, provides a list of solutions for **xDR232** installation problems.



### Overview

---

This section describes the physical installation of the remote unit (**xDR232**). The qualifications required for an installer are similar to those required to install standard office telecommunications equipment. Installers should be familiar with local construction techniques, requirements, and regulations associated with the installation of cabling and brackets in an urban or suburban environment. The installation personnel must be able to run simple diagnostic procedures.



**NOTE:**

The wiring described in this manual is only applicable within the same building and may not be extended to other structures.

A pipe-mounted **xDR232** is shown in Figure 5-1.

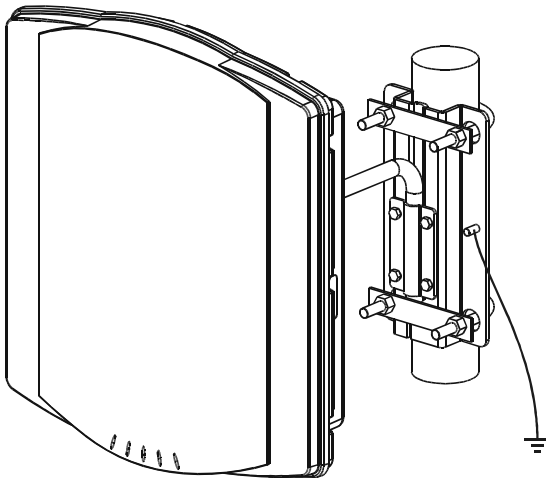

---

**Figure 5-1 Remote Unit (xDR232)**

### Safety Precautions

---

The NET service provider must ensure that each of the following requirements has been met:

- The building or tower has been certified as safe to climb.
- All exposed working areas have anchoring points or safety lines.
- All potential hazards have been identified, for example, fragile roofs, dangerous materials or machinery, and so on. Walkways should have been identified and marked out.
- Electrical installation work has been performed by trained and certified personnel.
- Safety devices have been inspected and certified.
- Safety glasses must be worn during installation.



**CAUTION:**

*The equipment installed must be properly grounded.*

***Failure to do this will invalidate the product warranty.***

### Installation Requirements for the xDR232

---

This section describes the physical installation requirements of the **WaveACCESS NET MDR232** and **SDR232**, as follows:

- **Installation Items Provided by Lucent**, page 5-4.
- **Additional Installation Items Required**, page 5-5.

### Installation Items Provided by Lucent

---

The following items are included in the Lucent Technologies installation kit per **xDR232**:

- Either a **WaveACCESS NET SDR232** single-drop remote, or a **WaveACCESS NET MDR232** multi-drop remote.
- One power/data adapter complete with a 5-foot (1.5m) cord.
- For the **WaveACCESS NET SDR232** only, a 4-foot (1.2m) 10Base-T Ethernet crossover cable (optional).
- A software diskette.
- One power/data cable of 10m, 30m, or 100m.
- This **WaveACCESS NET 2400** *Installation Guide*.
- CD-ROMs containing documentation and software drivers for end user PCs.
- Mounting bracket.
- AC cord.

When an additional antenna is required, you will receive a second package that includes the **WaveACCESS NET** antenna kit that was ordered with the system.



**NOTE:**

If any of these items are incomplete or missing, you might not be able to install the **WaveACCESS NET SDR232** or **MDR232**. In this case, please contact your nearest Technical Support Center. Refer to *Chapter 8, Technical Support* for more information.

The following is a list of the additional items available from Lucent Technologies per installation team:

- Cable tester (comcode #).
- Portable 24V battery pack (comcode #).

### **Additional Installation Items Required**

---

The following list describes the items that are not provided by Lucent Technologies, but that are required when installing the remote unit.

- Ethernet cable (PC/Hub to adapter)
- Power/data cable (power/data adapter to xDR) (see page 5-17)
- Bolts, mounting hardware
- Drill and drill bits
- Grounding cable
- Nut drivers
- Ladder
- Pliers
- Long-nose pliers (to remove plug-in terminal boards)
- Screwdrivers
- Safety glasses
- Silicone gel
- **Specialized wire stripping tools:**

## Installing the Remote Units

---

- Precision wire stripper  
OK Industries, model ST-550  
Details from [www.okindustries.com](http://www.okindustries.com)  
Available from: Newark Electronics, Tel. 800-463-9275
- Cable jacket cutter  
Ideal Cyclops, model 45-514
- Data cable cutter  
Ideal Cyclops, model 45-074  
Details from [www.idealindustries.com](http://www.idealindustries.com)
- Miniature needle nose pliers
- Phillips No. 1 screwdriver
- Flat screwdriver with 2.3 to 2.5 mm blade  
Available from: Allied Electronics, Tel. 800-433-5700
- Wrenches
- Multimeter
- Portable computer (with Windows95 or higher)
- Ethernet (10Base-T) hub (when required)
- Lightning Protection System (when required)
- Copy of the software drivers for the PC
- Copy of the User's Guide



### **CAUTION:**

*The **xDR232** wiring should not be installed next to AC electrical wiring. It must be a minimum of 60 cm away from conductors of circuits over 250V and a minimum of 3 meters or more away from circuits over 250V.*

### Installing the xDR232

---

This section provides information on installing the **xDR232**, as follows:

- **Choosing the Optimal Physical Location for the xDR232**, page 5-7.
- **Mounting and Attaching the xDR232**, page 5-7.
- **Cabling Recommendations**, page 5-17.
- **Connecting the Power/Data Cable between the xDR232 and the Power/Data Adapter**, page 5-19.
- **Connecting to the PC or LAN**, page 5-21.
- **Powering Up the xDR232**, page 5-24.
- **Aligning the xDR232 after Mounting**, page 5-24.

#### Choosing the Optimal Physical Location for the xDR232

---

Prior to installation it is essential to identify a remote unit installation site and prospective (intended) base stations for airlink.

Based on customer requests and the RF planning document, the installers should be provided with a location for the **xDR232** installation, the base station(s) locations, and channel numbers for the most likely base station candidates.

It is recommended that the **xDR232** be installed within line of sight of the **CU232**. This is not a requirement, but it will improve the signal quality in certain installations. In addition, it is also recommended that the **xDR232** be mounted in front of a wall or other structure, to minimize the occurrence of spurious signals from reaching the unit.

**CAUTION:**

*The xDR232s must be grounded to prevent the accumulation of atmospheric static charge on the chassis and to reduce unpredictable static discharges that may result in serious damage to the subscriber's equipment (Ethernet hubs, PCs, LANs, and so on), as well as the remote unit.*



### CAUTION:

When placing the **xDR232s**, the guidelines detailed in the *National Electric Code (NFPA 70)*, *Standard for Installation of Lightning Protection System (NFPA 780, 1995 edition)*, *Lucent Technologies 401-200-115*, and *Lucent Technologies Equipment Drawings* referred to in this document, and other applicable guidelines should be followed.

The **xDR232** mounting location should take into account the following requirements:

- The maximum distance from an **xDR232** to an internal AC power source is 100 m (300 ft.). The maximum distance between an **xDR232** and PC (10Base-T hub) is 100 m (300 ft.), as shown in Figure 5-2.

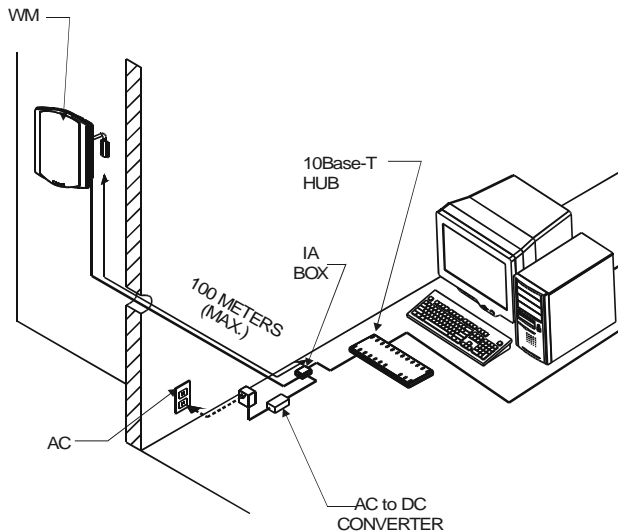

**Figure 5-2** Maximum Distance from xDR232 to PC



## Installing the Remote Units

---

- Provide sufficient lightning protection by locating the **xDR232** within the recommended lightning protection zone or by installing optional lightning protection equipment. For more information, refer to *Appendix A, Lightning Protection*.

### To identify the optimal **xDR232** mounting location:

1. Using a computer and the 24V battery pack attached to the **xDR232**, program the **xDR232** for one of the candidate **CU232** ESS-IDs.
2. Survey the possible outdoor mounting locations by pointing the remote unit toward the base station location and slowly rotating the **xDR232** about the azimuth (horizontal) and elevation (vertical) axes, as shown in Figure 5-3, while observing the LEDs on the side of the remote unit.

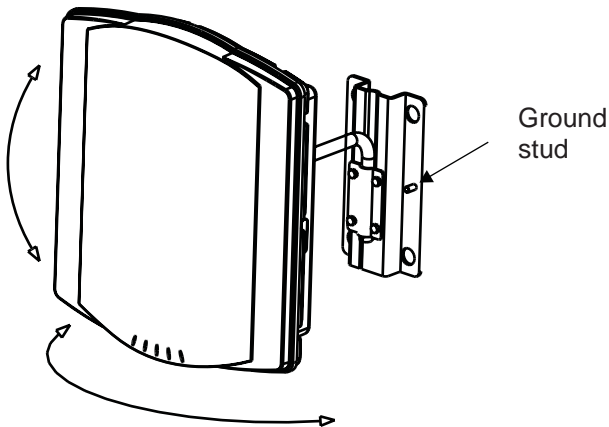

---

**Figure 5-3** xDR232 Survey Directions

## Installing the Remote Units

---

The LEDs provide feedback on the operating status of the **xDR232**, as shown in Figure 5-4.

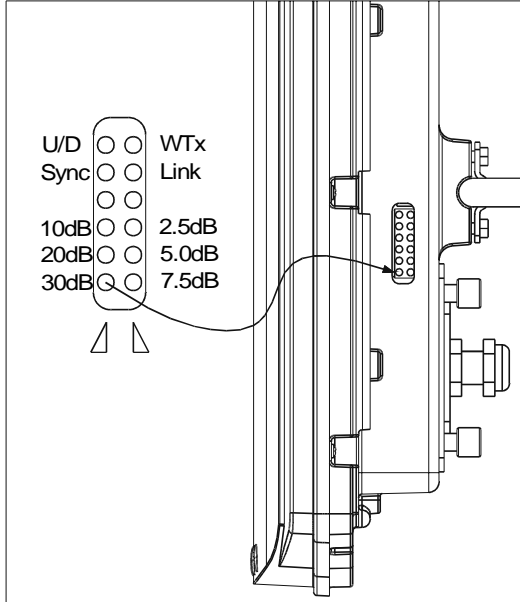

---

**Figure 5-4 LED Alignment**

Table 5-1 summarizes some of the conditions indicated by the LEDs.

## Installing the Remote Units

**Table 5-1 xDR232 Status**

| LED Nomenclature          | LED Condition                      |                                    |                                  |
|---------------------------|------------------------------------|------------------------------------|----------------------------------|
|                           | On                                 | Off                                | Blinking                         |
| Sync                      | Airlink established                | ----                               | No airlink                       |
| Link                      | <b>xDR232</b> connected to network | Network connection not established | ----                             |
| U/D                       | Reserved                           | Reserved                           | Reserved                         |
| WTx                       | Packets transversing the airwave   | ----                               | Packets transversing the airwave |
| 2.5, 5.0, 7.5, 10, 20, 30 | Signal strength                    |                                    |                                  |

Figure 5-5 shows how to read the signal strength from the LEDs.

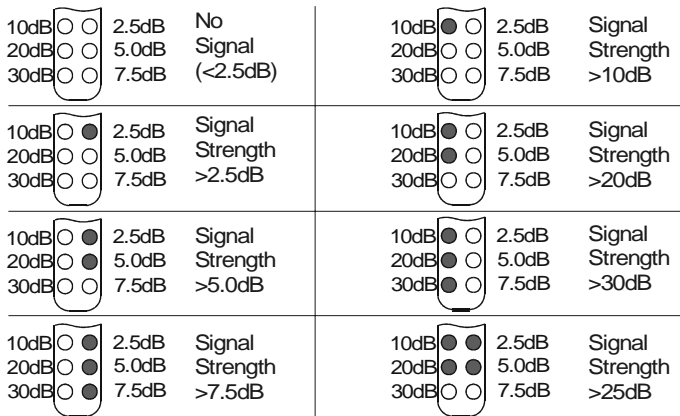

**Figure 5-5 xDR232 Signal Strength LEDs**

## Installing the Remote Units

---

3. Adjust the orientation of the **xDR232** to establish a “Sync” condition and maximize the signal strength. The minimum recommended requirement is that the 10dB indicator is lit. Record the signal level as indicated by the LEDs. When the signal measurements are taken, the **xDR232** should be positioned as close to the prospective mounting location as possible.
4. Reprogram the **xDR232** for the other **CU232** ESS-ID(s) and repeat the survey to determine the best direction, location, and signal strength for the remote unit.
5. For each **CU232**, record the ESS-ID and the signal strength and pass this information on to the network planner.

Table 5-2 displays an example of the form used for prospective base station channels.

**Table 5-2 Prospective (Intended) Base Station Channel List**

| <b>xDR Serial #</b> | <b>MAC Address:</b> |              |
|---------------------|---------------------|--------------|
| <b>CU232</b>        | ESS-ID #            | Signal Level |
| 1                   |                     |              |
| 2                   |                     |              |
| 3                   |                     |              |

### Mounting and Attaching the xDR232

---

The **WaveACCESS NET xDR232** should be mounted in front of a wall or other structure to minimize the occurrence of spurious signals from reaching the unit.

## Installing the Remote Units

There are two options available for mounting the remote units:

- Pipe-mounting the **xDR232**.

The first option is to mount the **xDR232** on a 30 cm long, 3.5 to 5.0 cm wide pipe, using two 2-1/2 x 3-1/2 x 3/8 inch (6.4 x 9 x 1 cm) u-bolts, along with the mating nuts and split lockwashers. Fasten the **xDR232** mounting bracket to the pipe using the strap, as shown in Figure 5-6 and Figure 5-7. This option is preferable.

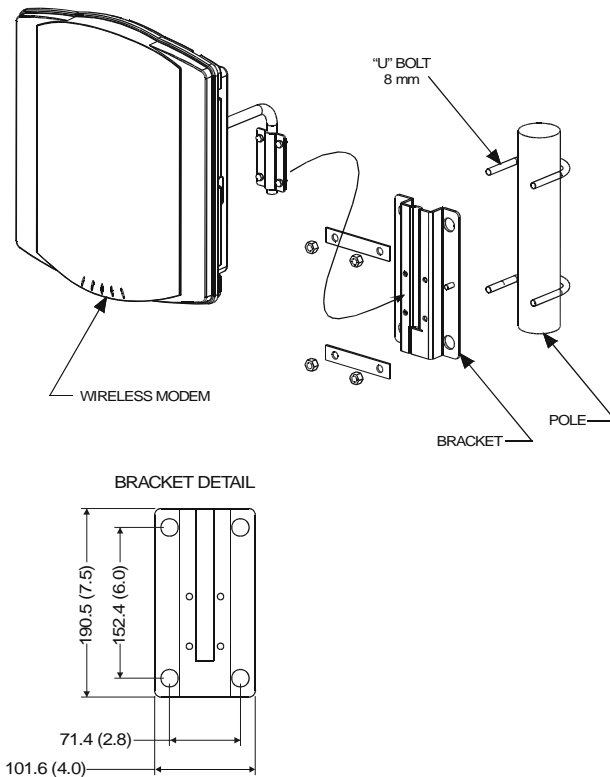
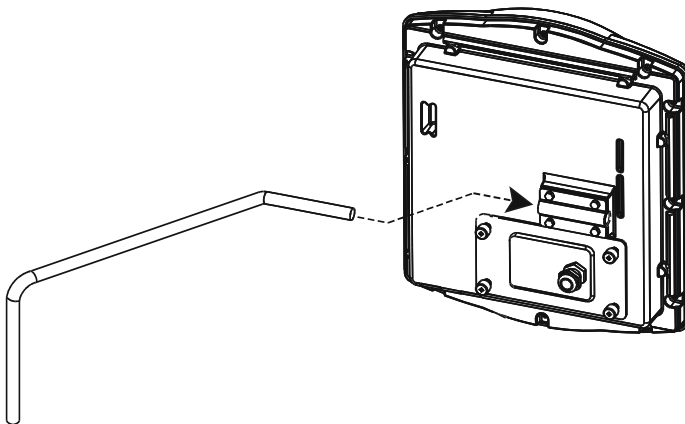

**Figure 5-6 Pole-Mounted xDR232**

## Installing the Remote Units

---

Figure 5-7 shows a rear-view of a pipe-mounted xDR232.



---

**Figure 5-7** Rear-View of Pipe-Mounted xDR232

## Installing the Remote Units

---

- Mounting the **xDR232** on a horizontal surface.

The second option is to use a ring stand bracket designed to be placed on a horizontal surface. For safety reasons, it may be necessary to secure the ring stand bracket using pipe clamps, as shown in Figure 5-8.

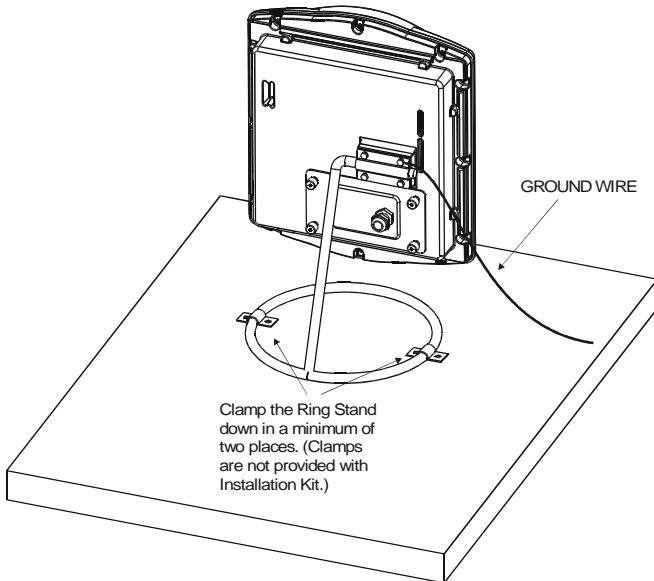

---

**Figure 5-8 Horizontal Surface Mount (Optional)**

### To mount and attach the **xDR232**:

1. Prepare for mounting the **xDR232** using one of the mounting methods described above.
2. After installing the mounting brackets, fasten the **xDR232** to the supports and point the **xDR232** in the direction of the **CU232**.

### Cabling Recommendations

---

The following cabling information should be noted:

The recommended cable (Madison Cable part number 15179) for connecting the **xDR232** to the power/data adapter can be purchased directly from the following manufacturer:  
Madison Cable Corporation (a division of AMP)  
125 Goddard Memorial Drive  
Worcester, MA 01603 USA  
508-752-2884

This cable must not be installed in airducts, air plenums or areas through which environmental air is routed.

3. If the power/data cable is to be routed through airducts or air handling areas, Madison Cable part number 15198 should be used.
4. The power/data cable must be installed at least 60 cm away from conductors of circuits over 250V and 3 m or more away from circuits over 250V.
5. The wiring descriptions in this manual are only applicable within the same building and may not extend to other structures.



## Installing the Remote Units

---

- The remote unit must be grounded, as shown in Figure 5-9.

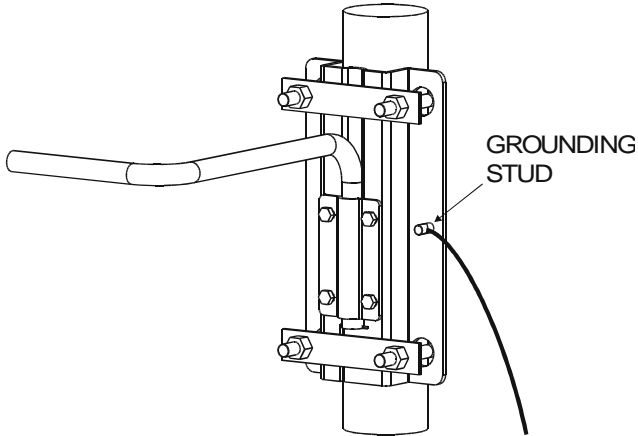

---

**Figure 5-9 xDR232 Bracket and Grounding Stud Location**



**NOTE:**

Lucent Technologies recognizes that UL approval does not supersede the electrical codes and other governmental rules and regulations, known collectively as “codes”. Therefore, any cable installation must be done in accordance with all the applicable codes. It is the responsibility of the installer to ensure that the cable installation satisfies all the required codes. Lucent does not assume liabilities that might arise from **xDR232** installations that are not performed in accordance with all the applicable codes.

### Connecting the Power/Data Cable between the xDR232 and the Power/Data Adapter

This step involves connecting the **xDR232** to a PC or LAN by installing the power/data cable between the **xDR232** and the power/data adapter. Figure 5-10 provides a guide to wiring the power/data adapter.

Cable Connection To Interface Adapter Box.

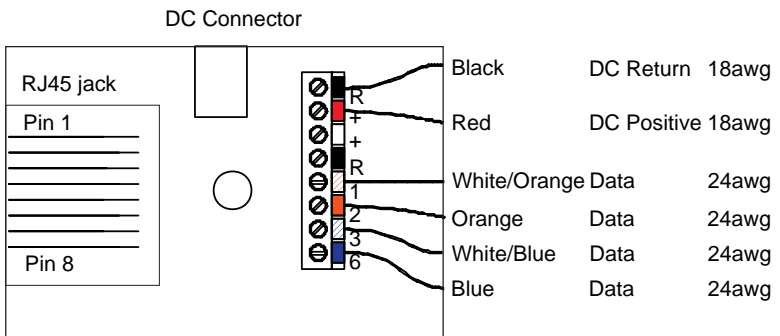

**Figure 5-10** Cable Connection to the Power/Data Adapter



#### **CAUTION:**

*The remote units must be grounded to prevent an atmospheric static charge from accumulating on the chassis and to reduce unpredictable static discharges that may result in serious damage to the subscriber's equipment (Ethernet hubs, PCs, LANs, and so on), as well as to the remote unit.*



### **CAUTION:**

*When installing the **xDR232**, follow the guidelines detailed in the National Electric Code (NFPA 70), Standard for Installation of Lightning Protection System (NFPA 780, 1995 edition), Lucent Technologies 401-200-115, and the Lucent Technologies Equipment Drawings referred to in this document.*

### **To connect the power/data cable between the xDR232 and the power/data adapter:**

1. Using the Cyclops cable jacket cutter (Model 45-514), strip the outer sheath 22 to 28 mm and remove the sheath, foil shield and the bare wire.
2. Untwist the pairs of wires. Set the strip length of the precision wire stripper (OK Industries Model ST-550) to 6mm and set the dial to 10. Strip the red and black wires.
3. Reset the precision wire stripper dial to 5 and strip the remaining 4 wires.
4. Push all 6 levers down.
5. Holding the power/data adapter in one hand, use the needle nose pliers to locate the red and black wires in the correct color-coded terminals of the terminal block and push the levers back to secure the wires.
6. Locate the orange pair of wires and tighten them. Locate and tighten the blue pair of wires.
7. Push the cable towards the terminal block so that the cable clamp grips onto the outer sheath. Pull the clamp tight with the needle nose pliers.
8. Check that the clamp is secure by slowly pulling the cable.
9. Locate the printed wiring board in the adapter. Put on the cover and tighten the screw with a No. 1 Phillips screwdriver.

## Installing the Remote Units

---

Figure 5-11 provides a guide to connecting the power/data adapter.

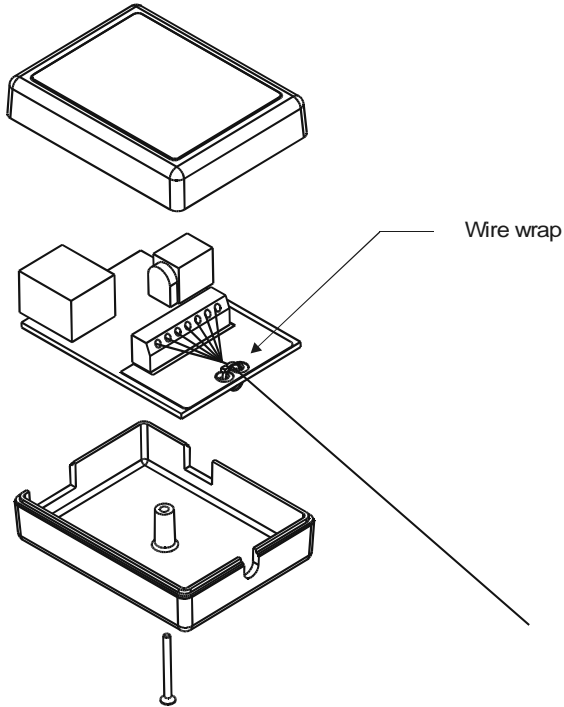

---

**Figure 5-11 Connecting the Power/Data Adapter**

### Connecting to the PC or LAN

---

This step involves connecting the **xDR232** to your PC or LAN using an Ethernet cable.

## Installing the Remote Units

---

- For single user installation connect the Ethernet cable from the power/data adapter to a PC using a "cross-over" cable format, as shown in Figure 5-12.

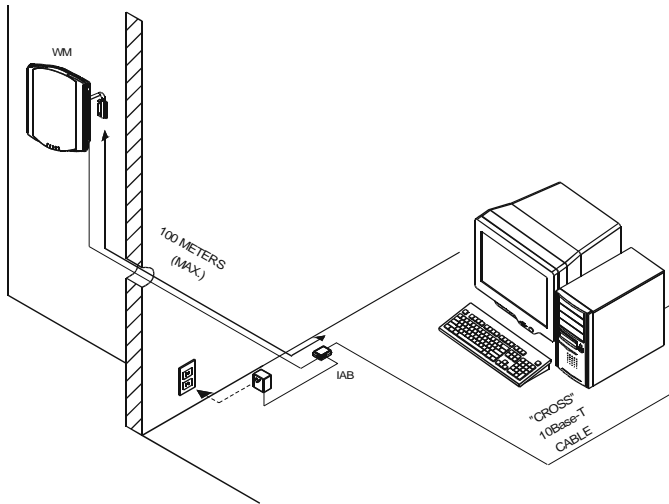

---

**Figure 5-12** Connection to a Single PC

## Installing the Remote Units

---

- For multiple user installations, use a "straight-through" cable format when connecting the power/data adapter to a LAN hub, as shown in Figure 5-13.

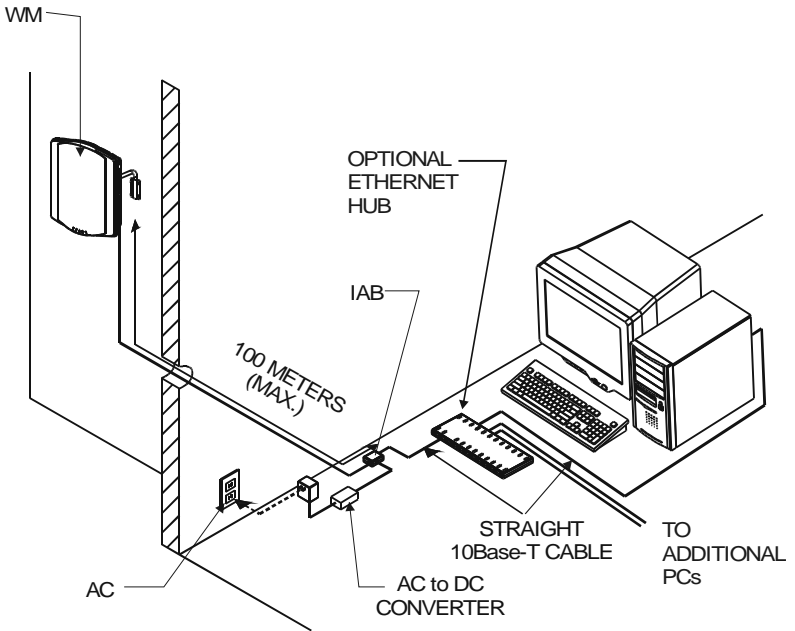

**Figure 5-13 Connections to a LAN**

## Installing the Remote Units

---

### Powering Up the xDR232

---

After they have been connected, the **WaveACCESS NET** remote units can be powered up.

#### To power up the xDR232:

- Plug the power supply into an AC outlet. The power supply is doubly insulated and therefore a ground outlet is not required.



#### NOTE:

When you are turning off the power to the **xDR232**, wait at least 10 seconds for the capacitors in the **xDR232** to discharge before reapplying power. If the capacitors do not discharge, the **xDR232** will not initialize properly.

### Aligning the xDR232 after Mounting

---

The **xDR232** should be aligned in order to receive maximum signal strength.

#### To align the xDR232:

1. Adjust the direction of the **xDR232** to receive the maximum signal strength, as indicated by the LEDs.
2. Perform the final physical alignment of the unit and tighten all mounting and grounding hardware.
3. Secure the cables.

### Lightning Protection

---

For information on lightning protection, refer to *Appendix A, Lightning Protection*.

### Troubleshooting

---

If the **xDR232** does not respond or operate after all the electrical connections are made and the software is loaded, refer to Table 5-3.

**Table 5-3 Troubleshooting**

| Symptom   | Remedy  |
|---|---|
| No LEDs are illuminated                                   | <ul style="list-style-type: none"><li>■ Check that AC is available at the wall outlet.</li><li>■ Verify that 24 VDC is present at the power/data adapter.</li><li>■ Check for 24 VDC at the plug-in connector of the <b>xDR232</b>.</li></ul> |
| Sync LED blinks   | <ul style="list-style-type: none"><li>■ Reposition the <b>xDR232</b> until the Sync LED stays lit.</li><li>■ Reprogram the <b>xDR232</b> to another <b>CU232</b> and realign for maximum signal.</li></ul>                                    |
| Sync LED blinks, but no signal level LEDs are illuminated | <ul style="list-style-type: none"><li>■ Reposition the <b>xDR232</b> until the signal level is provided.</li><li>■ Reprogram <b>xDR232</b> to another <b>CU232</b>.</li></ul>   |
| Sync LED is illuminated, but Link LED is dark             | Verify the cable connection between the <b>xDR232</b> and the power/data adapter.   |
| Low signal level  | <ul style="list-style-type: none"><li>■ Reposition the <b>xDR232</b> to increase the signal level.</li><li>■ Reprogram the <b>xDR232</b> to another <b>CU232</b> and realign for maximum signal strength.</li></ul>                           |





---

# Basic Software Configuration

# 6

---

## THIS IS AN INCOMPLETE DRAFT.

This chapter describes the mandatory basic software configuration procedures for the **WaveACCESS NET CU232**.

Other parameters can be configured in order to change the default values in the **CU232**, if necessary, using either the system configurator or a BootP server with TFTP capabilities. For more information on the additional configuration options available, refer to the *WaveACCESS NET User's Guide*.

### About this chapter:

**System Configuration Requirements**, page 6-3, describes the basic software configuration requirements.

**Accessing the Configurator Software**, page 6-3, describes how to open the Configurator software.

**Specifying the Unit's IP Address**, page 6-4, describes how to specify the IP address of the **WaveACCESS NET** unit.

**Defining the ESS-ID**, page 6-5, describes how to define the ESS-ID number of the **WaveACCESS NET** unit.



#### NOTE:

It is mandatory to define the ESS-ID of the **CU232**, before commencing use.

### System Configuration Requirements

---

The list below provides the requirements for configuring the system:

- PC computer, 486 66 MHz or higher, with at least 16 MB of memory and a 100 MB hard disk.
- Windows NT 4.0 or Windows 95 or Windows 98.
- A PC with an Ethernet connection situated on the same network as the units that are to be configured.
- Installed Configurator software.

### Connecting the WaveACCESS NET Unit to the PC or LAN

---

An Ethernet connection or cross-over cable from the power/data adapter supports communication between your PC and the **WaveACCESS NET**. For more information, refer to *Chapter 5, Installing the Remote Units*.

### Accessing the Configurator Software

The Configurator software is accessed using the icon on the Windows desktop or the Windows *Start* menu. The *Wave Access NET* window enables you to change many of the **WaveACCESS NET** unit's definable parameters, for example, the unit's IP address and ESS-ID number.

#### **To access the installation program:**

1. On your PC press **Ctrl Esc** to display the *Start* menu.
2. Select **Programs** and choose **WaveACCESS NET Configurator**. The *Wave Access NET* window is displayed.

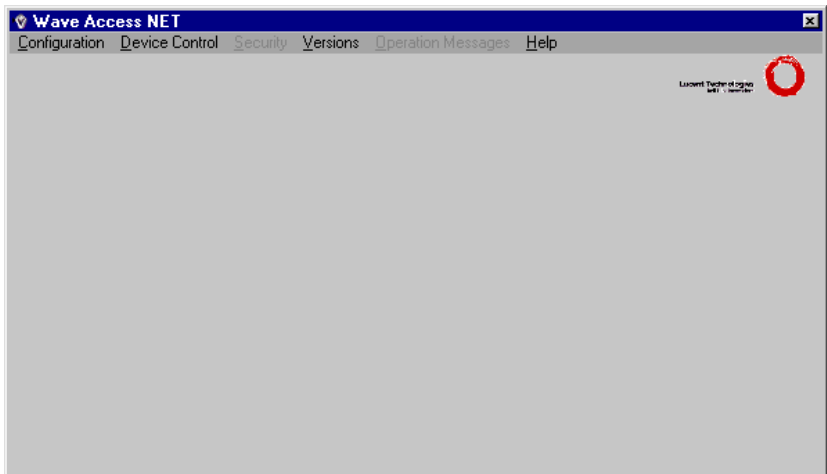

### **Specifying the Unit's IP Address**

---

All units come with a default IP address, namely 192.168.1.100. The Configurator software enables you to specify a unique new IP address for the **WaveACCESS NET** unit using BootP. This is essential since units on the same network cannot have the same IP address.

#### **To specify a unit's IP address:**

1. From the *Configuration* menu, select **System Management** to display a list of options.
2. Select **BootP Server** from the list. The ??? dialog is displayed.
  
3. Enter the MAC address and IP address of the **xDR232**.
4. Enter the system configurator file name.
5. ???

### Defining the ESS-ID

---

The Configurator software enables you to define the ESS-ID number of the **WaveACCESS NET** unit.

#### To define the ESS-ID:

1. From the *Configuration* menu in the *WaveACCESS NET* window, select **Host ID**. The *Host ID Configuration* dialog is displayed.

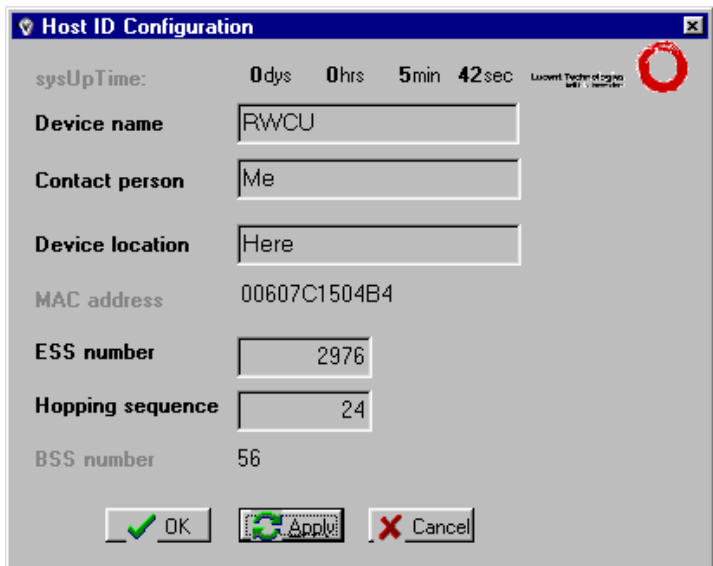

The image shows a screenshot of the "Host ID Configuration" dialog box. The dialog has a title bar with a blue background and a close button. The main area is light gray and contains several fields and labels. At the top right, there is a red circular logo with a white 'O' inside. The fields are: "sysUpTime:" with a value of "0dys 0hrs 5min 42sec"; "Device name" with a text box containing "RWCU"; "Contact person" with a text box containing "Me"; "Device location" with a text box containing "Here"; "MAC address" with a text box containing "00607C1504B4"; "ESS number" with a text box containing "2976"; "Hopping sequence" with a text box containing "24"; and "BSS number" with a text box containing "56". At the bottom, there are three buttons: "OK" with a green checkmark icon, "Apply" with a green circular arrow icon, and "Cancel" with a red 'X' icon.

|                  |                      |
|------------------|----------------------|
| sysUpTime:       | 0dys 0hrs 5min 42sec |
| Device name      | RWCU                 |
| Contact person   | Me                   |
| Device location  | Here                 |
| MAC address      | 00607C1504B4         |
| ESS number       | 2976                 |
| Hopping sequence | 24                   |
| BSS number       | 56                   |

2. In the **ESS number** field specify the ESS-ID number of the unit. The default ESS-ID value for the **CU232**, **MDR232** and **SDR232** is 5266. This option can be used to change the network identification.



**NOTE:**

For the **MDR232/SDR232** unit to be able to synchronize with the **CU232**, all the units must have the same ESS-ID number. If you have other **WaveACCESS** wireless networks, the ESS-ID number of this **MDR232** and **SDR232** must be different than the ESS-ID number of the units located within the other networks.

3. Click **Apply** to save the ESS-ID.  
Repeat this procedure for each **CU232**, giving each one the same ESS-ID.
4. Click **OK**. The **WaveACCESS NET** window is redisplayed.

---

# WaveACCESS NET 2400 Antennas

# 7

---

**THIS IS AN INCOMPLETE DRAFT.**

Both the **WaveACCESS NET CU232** and the **WaveACCESS NET xDR232** remote units have an embedded antenna. The installation and alignment of the antenna forms part of the unit installation. An external antenna can however, be used when wider coverage is desired.

**About this chapter:**

**CU232 Antennas**, page 7-2, describes the antenna and cable options available with the **CU232**.

**Remote Unit Antennas**, page 7-6, describes the antenna and cable options available with the **xDR232**.

**Installing an External Antenna**, page 7-8, describes the installation of an external antenna.

**Antenna Alignment**, page 7-12, describes the alignment of an external antenna.



### CU232 Antennas

---

This section describes the **WaveACCESS NET CU232** antenna options, as follows:

- **Internal Sector Panel Antenna**, page 7-2.
- **External Omnidirectional Antennas**, page 7-3.
- **Antenna Options and Specifications**, page 7-4.

#### Internal Sector Panel Antenna

---

The **CU232** is equipped with an internal sector panel antenna which enables the coverage of several wide angle sectors.



**NOTE:**

All of the **WaveACCESS NET** outdoor antenna options must be professionally installed. **These antennas must be professionally installed, complying with the certified antenna kits.** Please carefully review and follow the installation instructions included with each individual antenna kit. If you have any questions, please contact your nearest Technical Support center. Refer to in *Chapter 6, Technical Support* for information.

When an external antenna is required, an omnidirectional antenna is used, as described below.

## External Omnidirectional Antennas

---

The omnidirectional dipole antennas available for use with the **WaveACCESS NET CU232** are intended for external mounting and should be used when full 360° coverage is desired. When these antennas are mounted on a mast, they should be located as high as possible in order to avoid any other object being located beside it.

The **OM10** (and to some extent the **OM08**) omni antenna has a very narrow elevation (vertical) beamwidth. Both the height and distance separation between the two sites must be taken into consideration when selecting this antenna. In order to maximize the coverage area, you may want to order the appropriate down tilt option ahead of time, if it is available for that particular antenna.

The following table describes the physical characteristics of the omni antenna:

**Table 7-1 Physical Characteristics of the Omni Antenna**

| Antenna Type | Gain    | Catalog No. | Size (inches) | Mast Outside Diam. (ins.) |
|--------------|---------|-------------|---------------|---------------------------|
| Omni         | 10 dBi  | OM10        | 48 x 2.25     | 0.75-4.0<br>≤2            |
|              | 8.1 dBi | OM08        | 30 x 1.5      |                           |
|              | 5.1 dBi | OM05        | 13.5 x 1.3    |                           |



**NOTE:**

Some antennas have a female N-type connector, and some antennas have a male N-type connector. In case of the latter, a female-to-female N-type adapter should be supplied with the antenna.

All antennas should be mounted in a vertical polarization configuration (see the installation instructions included with each antenna kit).

### **Antenna Options and Specifications**

---

The table on page 7-5 displays the antenna options and their specifications. These figures reflect a 6-10 dB fade margin over ideal free space propagation and use the shortest permitted cable (see the minimum cable segment length in the table on page XXX). It is assumed that the remote end (**WaveACCESS NET SDR232** or **WaveACCESS NET MDR232**) uses its largest antenna, PG24, and the shortest permitted cable. The central antenna is assumed to have a horizontal deviation from the remote equal to a quarter of its horizontal beamwidth.



**NOTE:**

Irrelevant in the case of Omni antennas.

Where antennas with narrow elevation beamwidths are employed, and the remote unit is located at a significant height difference, the remote unit may not be within the main beam of the antenna. To avoid this situation, optimize the antenna tilt for the remote unit.

The following table provides antenna options for the U.S., Canada and Europe:

**Table 7-2 U.S., Canadian and European Antenna Options**

| Country<br>Antenna<br>Specific-<br>ations | Antenna<br>Type                          | Gain<br>(dBi) | Beamwidth<br>Horizontal/<br>Vertical | Down<br>Tilt          | Range<br>at 3.2<br>Mbps<br>(miles) | Range<br>at 1.6<br>Mbps<br>(miles) |
|---|--|---------------|--------------------------------------|-----------------------|------------------------------------|------------------------------------|
| U.S.                                      | Omni                                     | 8             | 360° / 15°                           | N/A                   | 1.5                                | 6.1                                |
|   | Sector<br>Panel<br>(Internal<br>Antenna) | 12            | 90° / 10°                            | N/A                   | 2.6                                | 10.3                               |
|   | Dipole                                   | 2             | 360° / 75°                           | N/A                   | 0.9                                | 3.6                                |
| Canadian                                  | Omni                                     | 8             | 360° / 15°                           | N/A                   | 1.8                                | 6.3                                |
|   | Sector<br>Panel<br>(Internal<br>Antenna) | 12            | 90° / 10°                            | N/A                   | 3.0                                | 10.5                               |
|   | Dipole                                   | 2             | 360° / 75°                           | N/A                   | 1.0                                | 3.1                                |
| European<br>(ETSI)                        | Omni                                     | 10<br>8       | 360° / 8°<br>360° / 15°              | 0°, 2°, 4°<br>N/A     | 0.9<br>0.7                         | 3<br>2.5                           |
|   | Sector<br>Panel<br>(Internal<br>Antenna) | 16<br>12      | 90° / 7°<br>90° / 10°                | w/<br>brackets<br>N/A | 1.4<br>0.9                         | 5<br>3.5                           |
|   | Dipole                                   | 2             | 360° / 75°                           | N/A                   | 0.2                                | 0.8                                |



**NOTE:**

A dipole antenna is used when conducting indoor testing.

### Remote Unit Antennas

---

This section describes the **WaveACCESS NET xDR232** antenna options, as follows:

- **Parabolic Grid Antenna**, as described below.
- **Antenna Options and Specifications**, page 7-7.

The tables on the following pages show the antenna specifications for the **WaveACCESS NET** remote antennas. The available antenna options depend on your country's regulations, for example, FCC Part 15, ETSI ETR-328, and so on. Not all of these options may be available in your country.



**NOTE:**

All of the **WaveACCESS NET** outdoor antenna options must be professionally installed. **These antennas must be professionally installed, complying with the certified antenna kits.** Please carefully review and follow the installation instructions included with each individual antenna kit. If you have any questions, please contact your nearest Technical Support center. Refer to in *Chapter 6, Technical Support* for information.

### Parabolic Grid Antenna

---

This is the highest gain antenna available for the **WaveACCESS NET** remote units. It is recommended for long range situations. Careful aiming of this antenna is required due to its small coverage angle.

## Antenna Options and Specifications

---

The following table displays Parabolic Grid antenna specifications when communicating with a **WaveACCESS NET CU232** utilizing a 10 dBi omni antenna:

**Table 7-3 Parabolic Grid Antenna Specifications**

| Country Antenna Specifications | Gain   | Beamwidth Horizontal/ Vertical | Down Tilt | Range at 3.2 Mbps | Range at 1.6 Mbps |
|--------------------------------|--------|--------------------------------|-----------|-------------------|-------------------|
| U.S.                           | 24 dBi | 10°                            | N/A       | 1.9               | 7.7 miles         |
| Canadian                       | 24 dBi | 10°                            | N/A       | 2.2               | 7.9 Km            |
| European (ETSI)                | 24 dBi | 10°                            | N/A       | 0.9               | 3 Km              |

The following table provides the physical characteristics of the **WaveACCESS NET** antennas:

**Table 7-4 Physical Characteristics of the WaveACCESS NET Antennas**

| Antenna Type   | Gain   | Catalog No. | Size (inches) | Mast Outside Diam. (inches) |
|----------------|--------|-------------|---------------|-----------------------------|
| Parabolic Grid | 24 dBi | PG24        | 27 x 32       | 0.75 - 2                    |

### **Installing an External Antenna**

---

This section describes the installation of the external antenna, as follows:

- **Antenna Installation Procedure**, page 7-10.
- **Power Compliance**, page 7-10.

The ruggedized **WaveACCESS NET CU232** with embedded antenna is installed outdoors. There is also an option to install an external antenna for both the **CU232** and the **xDR232** providing wider coverage. When the external antenna is used it is connected directly to the radio output.

Before you install the **WaveACCESS NET** unit you must choose a good location for your antenna to ensure a line of sight to:

- The **WaveACCESS NET CU232** and,
- The **WaveACCESS NET xDR232** remote stations.

A fixed cable connects the **xDR232** to the external antenna and they are mounted one next to the other.



#### **WARNING:**

*The **WaveACCESS NET** unit antennas should be installed **ONLY** by experienced antenna installers familiar with local building and safety codes and, wherever necessary, licensed by appropriate government regulatory bodies. Failure to do so may void the Product Warranty as well as expose the end user to legal and financial liabilities. Lucent Technologies, its agents, resellers, or distributors, are not liable for injury, damage or violation of government regulations associated with the installation of the antenna.*



### **WARNING:**

*The installer is also responsible for ensuring that the public is not exposed to radio frequency energy levels in excess of the FCC guidelines. Those guidelines imply that no human may conceivably be found within one foot of the front of the antenna. If such a situation is likely to occur, the installer is responsible for placing the appropriate caution signs to warn the public. Lucent Technologies, its agents, resellers, or distributors, are not liable for exposure to excessive RF energy levels due to improper antenna installation.*

*The Maximum Permissible Exposure guidelines are 1 foot (30 cm) for the **WaveACCESS NET** unit, as based on the National Council on Radiation Protection and Measurement (NCRP). If the antenna is in an accessible area, an appropriate warning sign **must** be installed in the appropriate place.*



### **WARNING:**

*Using an antenna or cable other than those supplied or recommended for use with the **WaveACCESS NET** units, whether installed indoors or outdoors, could cause degradation of the system and could void your authority to operate this equipment. In addition, **the use of unauthorized antennas or external amplifiers violates Federal law and FCC's regulations**. This may void the Product Warranty, as well as expose the end user to legal and financial liabilities.*





### **WARNING:**

*The **WaveACCESS NET** antenna emits high radio frequency energy levels. In situations where unauthorized persons may approach within 1 ft (30 cm) of the front of the antenna, an appropriate warning sign should be placed near the **WaveACCESS NET** antennas.*

## **Antenna Installation Procedure**

---

The following procedure describes how to install the antenna for the **WaveACCESS NET CU232** and **xDR232**:

### **To install the antenna:**

1. Mount the antenna using the enclosed brackets, following the instructions included with the antenna and cable kit that you purchased.
2. Align the antenna so that it is pointing directly towards:
  - a. The **xDR232** that the **CU232** needs to cover.  
and/or
  - b. The **WaveACCESS NET CU232** that the **xDR232** will be communicating with.  
Please ensure that antenna polarization (horizontal or vertical) is identical on the receiving and transmitting ends.

## **Power Compliance**

---

The system, if required by regulation, performs transmit power adjustment based on the installed antenna and cable.

Make sure that you enter the correct antenna and cable parameters in the antenna configuration software so that it complies with your country's requirements. Incorrect antenna parameters may cause the system to malfunction and invalidate your warranty.



**WARNING:**

*Willfully entering incorrect values in the antenna parameters software as supplied with the **WaveACCESS NET** units, could cause degradation of the system and void the authority to operate this equipment. In addition, **improper transmit power settings violates unlicensed band radio frequency regulations**. This may void the Product Warranty, as well as expose the end user to legal and financial liabilities.*

### **Antenna Alignment**

---

This section provides a basic guide for aligning antennas for a high gain link. It also explains the basics of link budget calculation, as follows:

- **Antenna Placement and Alignment**, page 7-12.
- **Calculating the Link**, page 7-15.
- **Calculating the Antenna Elevation Angle**, page 7-16.
- **Setting the Azimuth Alignment**, page 7-18.
- **Directional Alignment**, page 7-19.
- **Software for Antenna Alignment Calculations**, page 7-20.

For more information on using the LEDs to measure the strength of the signal, refer to Chapter 5 "Installing the Remote Units".

### **Antenna Placement and Alignment**

---

When you are building a central site, the type and location of the antennas must be carefully chosen in order to enable optimal communication between the collocated central units and the remote units.

The following factors must be taken into consideration when choosing antennas and their placement at the central site:

- Boundaries.
- Fresnel Zone.
- Antenna Elevation.

### Boundaries

The boundaries are defined by calculating the coverage range of the antenna, based on antenna beamwidth and gain specifications. Basically, the boundaries of the antennas used at a central site must be compatible with the area you need to cover. Keep in mind that the higher the gain, the narrower the beamwidth. Thus, the antenna may cover a longer distance, but a narrower sector.

When placing antennas at the central site, you must take into account the total area you want to cover. You can then calculate the sectors to be covered by each antenna, based on the predicted range calculation, according to the specifications of the specific antenna.

It is recommended that the boundaries of the antennas overlap a little, so that there are no gaps in the coverage area. However, make sure that they do not intersect one another, as this will cause disturbances in performance.

In order to calculate the link for antenna alignment, you need to consider the following basic data:

- Distance between the central unit antennas and the remote unit.
- Height difference.
- Types of antennas being used.
- Types of cables, and losses for the leads being used.

After obtaining this data, the expected path loss and required antenna elevation angle can be calculated. To assist in calculating the link loss and fade margins, a special Excel-based worksheet is provided on the **WaveACCESS NET** software diskette.

### Fresnel Zones

When positioning the antennas, you need to ensure that there is line of sight between the central site antennas and the remote unit. Most importantly, the first Fresnel zone must be clear. The following diagram illustrates how to calculate the Fresnel zone:

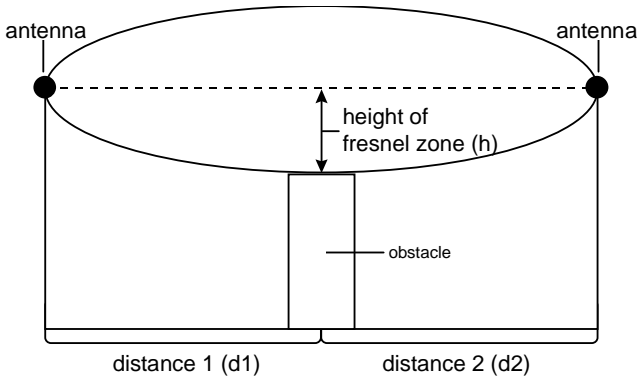

$$h = \sqrt{\frac{0.125 \cdot d1 \cdot d2}{d1 + d2}}$$

---

**Figure 7-1 Calculating the Fresnel Zone**

### Antenna Elevation

Antennas in a collocated system are usually installed with 0° tilt. However, where antennas with narrow elevation beamwidth are used, and the remote unit is located at a significantly different height, you may have a situation where the remote unit is not within the main beam of the antenna. In such a case, you need to optimize the tilt of the remote unit. For information about calculating the antenna elevation angle, refer to page 7-16.

### Calculating the Link

---

To calculate the link, the following basic data is required:

- Distance between the two points.
- Height difference between the two points. If the height difference is larger than the antenna vertical beamwidth allows, it will affect the elevation setting of the antenna.
- Type of antenna being used (i.e., gain and beamwidth).
- Type of cables, and losses for the leads being used.

After obtaining the above data, the expected **path loss** and required **antenna elevation** angle can be calculated.

**WaveACCESS NET**'s Excel-based calculation tool, which is provided on the enclosed software diskette, is used to calculate the free space path loss and fade margin for a specific link. Use this spreadsheet to determine your optimal setup and expected performance. Refer to the section, *Software for Antenna Alignment Calculations*, on page 7-20, for further details.

## Calculating the Antenna Elevation Angle

---

The antenna elevation angle at each point is calculated in order to achieve maximal performance. This is done using the following equation:

$$\alpha = \tan^{-1} \left( \frac{\Delta H}{\text{dist}} \right)$$

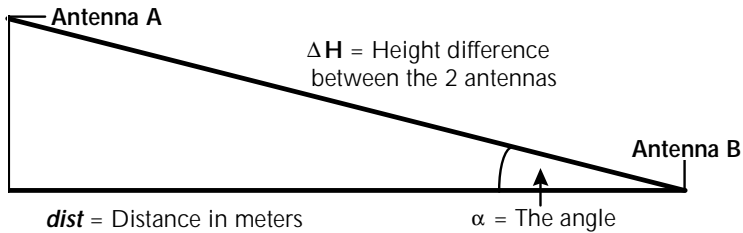

The angle  $\alpha$  is used for both antennas. The lower antenna must be directed upwards by  $\alpha$  and the higher antenna must be tilted downwards by  $\alpha$ .

The elevation alignment is made in the following manner:

$$\alpha = \sin^{-1}\left(\frac{G}{D}\right)$$

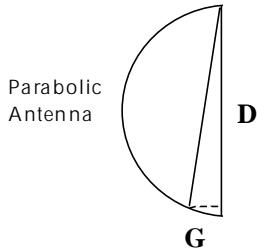

$\alpha$  – Elevation angle

**G** – Distance between edge of antenna to string (cm)

**D** – Diameter of Antenna (cm)

The higher antenna must be aligned first.

### To align the antenna:

1. Attach a weighted string to the higher antenna.
2. Measure the distance (**G**) and the antenna diameter (**D**) and use the equation shown on the preceding page to calculate  $\alpha$ .
3. Use the same method to align the second antenna to the maximal reception from the first antenna.



#### NOTE:

If the angle  $\alpha$  formed by the height of the antennas has a difference of less than the antenna's vertical opening  $\beta$  by a factor of at least four (i.e.,  $\beta \geq 4 \alpha$ ) it is not necessary to perform vertical alignment. In that case, the antenna should **only be aligned to the horizontal**.



### **Setting the Azimuth Alignment**

---

The next step in setting up the link is the azimuth (or horizontal) alignment. In order to do this, you must achieve as accurate a direction as possible from one antenna to the other. This can be done using a good map or GPS system that can give accurate coordinates and point you in the right direction. If none of the above is available, a good compass and a pair of binoculars (to see the other end) can be used.

#### **To set the azimuth alignment:**

1. Align each antenna directly towards the other.
2. Lock one of the antennas.
3. Adjust the unlocked antenna in order to find and prove that the antenna is receiving the best possible signal strength. Do this by moving it horizontally in one direction until the signal strength peaks and then goes down by at least 5 dB (as shown using the RSSI indicator in the monitor of each unit).



#### **NOTE:**

It is important to move the antenna at an angle of at least four times its horizontal opening to ensure the antenna's main lobe is being measured, not a side lobe with its subsequent low power.

4. Now turn the antenna in the opposite direction and repeat the procedure in number 3.

5. Return the antenna to the highest peak previously achieved and lock it in place, using the correct tools.



**NOTE:**

If a signal cannot be received from the other system, and/or the units do not synchronize, even though there should be enough fade margin for the link, you need to move the antenna at a lower speed.

Attempt to move the antenna laterally at a rate of  $1^{\circ} - 2^{\circ}$  per second to allow the unit to properly detect the other unit's signal.

6. Repeat the above steps at the second site.



**WARNING:**

*Make sure that the antennas are tightly locked in place, otherwise harsh meteorological conditions (strong winds, storms, and so on,) may cause the settings to change.*

### Directional Alignment

---

This process is comprised of the following steps:

1. Aligning the two antennas with a compass to the correct direction.
2. Fine-tuning one antenna to its maximum Rx strength.
3. Fine-tuning the second antenna until it reaches maximum Rx strength.

### Software for Antenna Alignment Calculations

---

Since **WaveACCESS NET** systems in the ISM band use frequency hopping, a special feature has been included to help with the installation of high gain point-to-point links. This software utility is capable of:

- Limiting transmission to one frequency only.
- Providing statistics about noise level in the area.
- Giving RSSI (signal strength above threshold) readings.

These special features are accessed through the ASCII monitor system of the units.

The special screen which enables setup of the unit for single frequency transmission is available only to Authorized **WaveACCESS NET** resellers and distributors, and may not be used by the end user.



**NOTE:**

Most countries do not allow an ISM band Spread Spectrum device to transmit only on a single frequency. This utility is to be used very sparingly, and **only for antenna alignment** purposes.

In order to maximize compliance with laws and regulations, the unit reverts to Hopping mode whenever it is reset.

---

## **Technical Support**

# **8**

---

**AWAITING INFORMATION.**

---

**THIS IS AN INCOMPLETE DRAFT.**



---

# Appendix A: Lightning Protection



---

## THIS IS AN INCOMPLETE DRAFT.

This section provides information on the reasons and methods of lightning protection for the **WaveACCESS NET** product family, as follows:

- **Why is Lightning Protection Required?**, page A-2.
- **Methods of Lightning Protection**, page A-3.
- **Lucent Technologies Lightning Protection Unit**, page A-7.
- **Considerations for LPS Design**, page A-9.

The **CU232** and **xDR232** enclosure and the I/O cable shielding must be properly grounded in order to provide protection against lightning, surges, and static buildup. Failure to do so will invalidate the product warranty.



### **CAUTION:**

*The **CU232** and **xDR232** bracket must be grounded using a minimum of a No. 10 AWG wire (6 AWG in Canada), or by adhering to the local electric code.*

The **CU232** and **xDR232** include Gas Discharge Tubes (GDT) as secondary lightning protection devices. These devices clamp the excess voltage, surge, or static buildup that exceeds 90 Volts. However, other factors may warrant additional optional protections for the unit, especially in geographical areas where lightning storms are a common occurrence.

### Why is Lightning Protection Required?

---

The need for protection is influenced by the Network or Service Provider's assessment of the importance of the **WaveACCESS NET** element. This includes the following:

- Likelihood of lightning strikes.
- Cost of a Lightning Protection System (LPS).
- Cost of a voided warranty and the replacement of system elements.
- Cost of repair work.
- Cost of information that is lost or destroyed.
- Loss of revenue.
- Relative risk of fire and electric shock.
- Potential health and safety risks.

The British Standard BS 6651: 1992 provides a simple mathematical overall risk factor analysis for assessing whether a structure requires protection.

### Methods of Lightning Protection

---

The best method to use to reduce the risk of lightning strikes is avoidance. The **CU232** and **xDR232** must be mounted within a zone of protection, namely, the 45° lightning protection cones provided by the building structure, or an existing LPS. The 45° cone of protection applies to tower-mounted units as well, as shown in Figure A-1 and Figure A-2.



#### **CAUTION:**

*Failure to provide a lightning protection zone will void the warranty.*

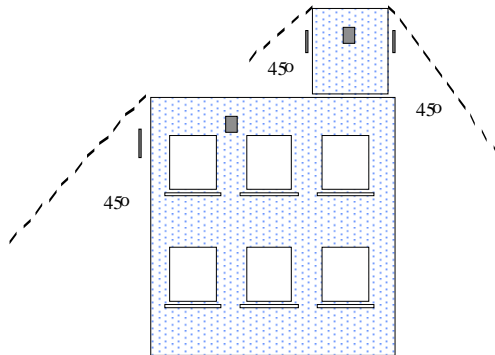

---

**Figure A-1 Typical Zones of Protection on a Building**



## Appendix A: Lightning Protection

---

Figure A-2 shows the typical zones of protection on a tower.

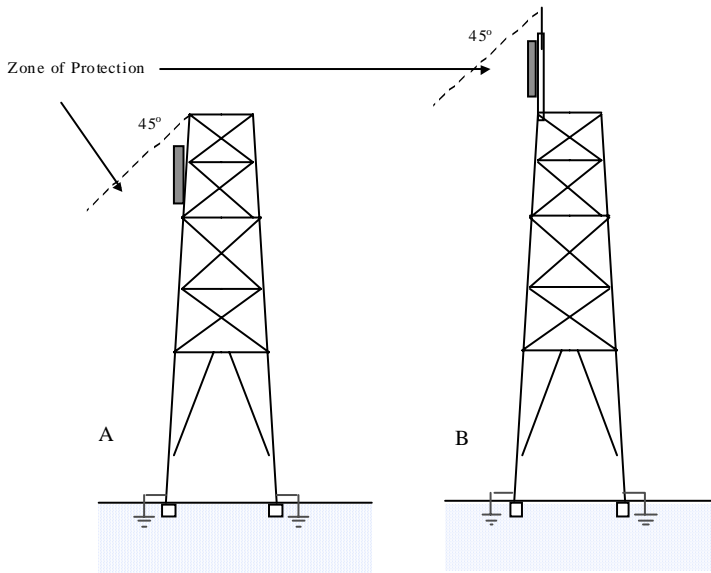

---

**Figure A-2 Typical Zones of Protection on a Tower**

If the **CU232** and/or **xDR232** cannot be mounted within a zone of protection, an LPS must be introduced or extended to provide a new zone of protection for the **CU232** and/or **xDR232**, as shown in Figure A-2, Tower B.

## Appendix A: Lightning Protection

---

A braided wire is typically used to ground the **CU232** or **xDR232** to the structure's main grounding point. The existing LPS is also connected to the same point. The grounding point for the **CU232** is located on the right side of the mounting bracket.

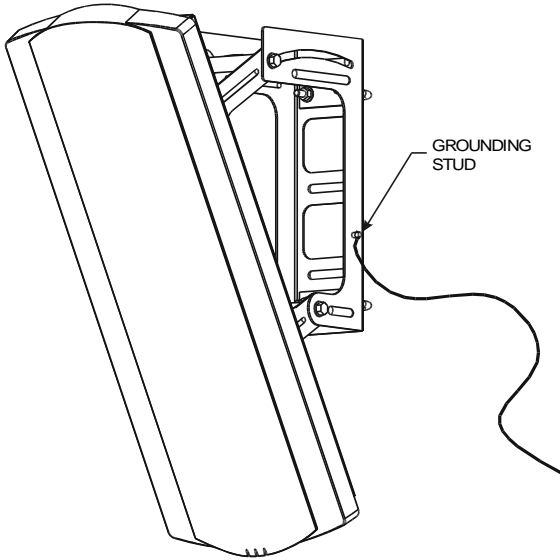

---

**Figure A-3 CU232 Grounding Stud Location**

## Appendix A: Lightning Protection

---

The grounding point for the **xDR232** is a threaded stud on the bracket, as shown in Figure A-4.

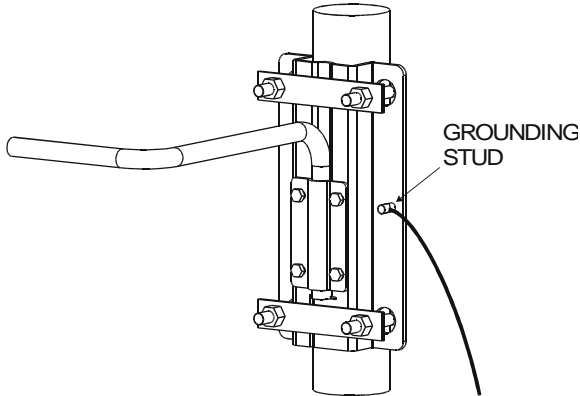

---

**Figure A-4 xDR232 Bracket and Grounding Stud Location**

The bare, non-insulated drain lead of the I/O cable, which includes the 10Base-T wires and power leads, must be connected to the ground terminal (green-colored) on the plug-in terminal block on the **CU232** or **xDR232**.

The shield and drain wires, inside the power/data adapter, must be cut back to the insulation to prevent the current from flowing back into the building.

Refer to page A-9 for design recommendations that should be considered when a Lightning Protection System must be installed or extended.

### Lucent Technologies Lightning Protection Unit

---

Additional protection in lightning-prone areas can be provided by installing a Lucent Technologies Lightning Protection Unit, as shown in Figure A-5.



Dimensions: 170 mm W x 50 mm D x  
200 mm H

Material: Markroben

Two cable entry points, with rubber grommets

No gasket

Gas tubes (GDT) meet ITU K.12 specifications

Earth studs, connected by a fusible link

---

**Figure A-5 Lightning Protection Unit**

This is an outdoor unit that provides secondary protection to the incoming cable. It includes gas discharge tubes for line protection and a fusible link between two earth studs. When high current develops between the incoming and outgoing earth studs the fusible link provides extra protection. This device may not be required for every installation.



**NOTE:**

The Lightning Protection Unit is not currently available.

## Appendix A: Lightning Protection

---

*Lucent Technologies' products provide only secondary protection against lightning discharges. Primary protection is provided by locating the products in a recognized "zone of protection", connecting to a LPS, and complying with the applicable governmental regulations. There can be no assurance that the products will survive electrical discharges from lightning at or in the vicinity of the products even when primary protection is in place. Lucent Technologies does not warrant its products against damage from such discharges. All costs to repair such damage for which Lucent Technologies is not responsible, including any costs of restoring such secondary protection, shall be the responsibility of the party seeking such repair.*

### Considerations for LPS Design

---

The following design recommendations should be considered when a Lightning Protection System (LPS) must be installed or extended. These recommendations are also affected by local regulations that may impose additional standards. These are the principal elements of an LPS:

- Air termination networks
  - New LPS or system integration into an existing LPS.
- Down conductors
  - Types of conductors and spacing.
  - Routing of conductor.
- Earth termination networks
  - Protecting equipment and buildings.
  - Protection of people.
  - Soil conditions namely, temperature, moisture, chemical composition.
  - Choosing a grounding system namely, design life, soil resistivity, design.
- Bonding to prevent side flash.

### Earth Termination Networks

---

It is recommended that deep-driven earth electrodes be used, as they are more likely to reach permanent moisture and be unaffected by seasonal changes. Where it is impossible to drive earth rods deep enough, several rods may be used together in a matrix. Although it may be possible to use the reinforcing bars within the structure's foundations, precautions must be taken to ensure that there is electrical continuity.



**NOTE:**

Due to increased use of plastic/PVC components, buried water pipes are not considered reliable.

### **Bonding**

---

All metal work on or around a structure must also be bonded to the LPS. When an LPS is struck, its electrical potential with respect to earth rises. Unless all metal work within a fixed distance is bonded, the discharge will seek an alternative path to earth by side flashing to other metal work in or on the structure. Tables for calculating suitable "isolation" distances are listed in BS 6651 (British Standard).

### **System certification and maintenance**

---

Installing an LPS entails much more than placing a copper rod in the ground and connecting the **WaveACCESS NET** unit enclosure and mounting pole to it. It is recommended that a local lightning protection consultant or installation company be engaged to carry out the design, installation, and maintenance of such systems. Once a system has been designed and installed, it may be required to be inspected and certified to be in compliance with local regulatory standards. Annual inspection and testing is recommended to ensure that the LPS still functions according to its design specification.

### **Lightning protection system suppliers**

---

Lucent Technologies makes no recommendations on suppliers of lightning protection systems. The following is for reference only.

## Appendix A: Lightning Protection

---

- **In the U.K.:** WJ Furse & Co Ltd, Wilford Road, Nottingham, NG2 1EB  
(Tel: 44 1159 863471 Fax: 44 1159 860538)  
All materials supplied by Furse meet UL467, IEC1024, BS6651 and BS7430 standards.
- **In the U.S.:**  
Benfield Electric International Ltd.  
55 Lafayette Ave  
White Plains, New York 10603  
(Tel: 914 948 0995 Fax: 914 328 7071)
- **In the Far East:**  
IT Systems Sdn Bhd  
P.O. Box 2339  
Bandar Seri Begawan 1923  
Negra, Brunei  
(Tel 673 256 2180 Fax 673 256 2179)

### Example of Lightning Protection System

---



#### **WARNING:**

*The following design does not constitute a proposal. It may be necessary to substitute components or to alter the physical layout from that shown, depending on local regulations. This is only an example.*



#### **NOTE:**

To avoid the effects of galvanic corrosion, it is essential that dissimilar metals not be bonded together or in physical contact. For example, if the mounting pole is aluminum, then an aluminum Air Terminal should be used. Any transition from copper to aluminum must be made via an appropriate bimetallic connector.



## Appendix A: Lightning Protection

---

Copper or aluminum can be used above ground for the LPS; however, because the **WaveACCESS NET** unit is made of aluminum, an aluminum system is recommended. Where the system enters the ground, a bimetallic coupler **must** be used.

Copper or stainless steel should be used for the LPS below ground; stainless steel should be considered if galvanic corrosion is an issue.

The item numbers shown in Table A-1 and Table 1-2 refer to the elements shown in Figure A-6.

**Table A-1 Aluminum Parts Description for Tower LPS**

| <b>Item</b> | <b>Description</b>                                |
|-------------|---|
| 1           | Air Terminal 500 mm                               |
| 2           | Pipe bond (50 - 200 mm diameter)                  |
| 3           | Cable socket/lug                                  |
| 4           | Heavy duty cast saddle clamps                     |
| 5           | Bare solid circular conductor 8 mm diameter       |
| 6           | Tee Clamp   |
| 7           | Test clamp  |
| 8           | Bimetallic connector 8 mm diameter to copper tape |
| 9           | Non-Metallic DC clip for PVC tape (brown)         |

**Table 1-2 Copper and Stainless Steel Parts Description for Tower LPS**

| <b>Item</b> | <b>Description</b>   |
|-------------|----------------------|
| 10          | Earth Pit            |
| 11          | Earth rod 1200 mm    |
| 12          | Earth rod coupling   |
| 13          | Earth rod drive stud |

## Appendix A: Lightning Protection

---

**Table 1-2 Copper and Stainless Steel Parts Description for Tower LPS**

| <b>Item</b> | <b>Description</b>                           |
|-------------|--|
| 14          | Earth rod spike for copper & stainless steel |
| 15          | PVC covered tape 25 x 3 mm (brown)           |
| 16          | Rod to tape clamp up to 16 mm copper         |



**NOTE:**

The above list does not include the mounting pole for the xDR232 or mounting hardware.

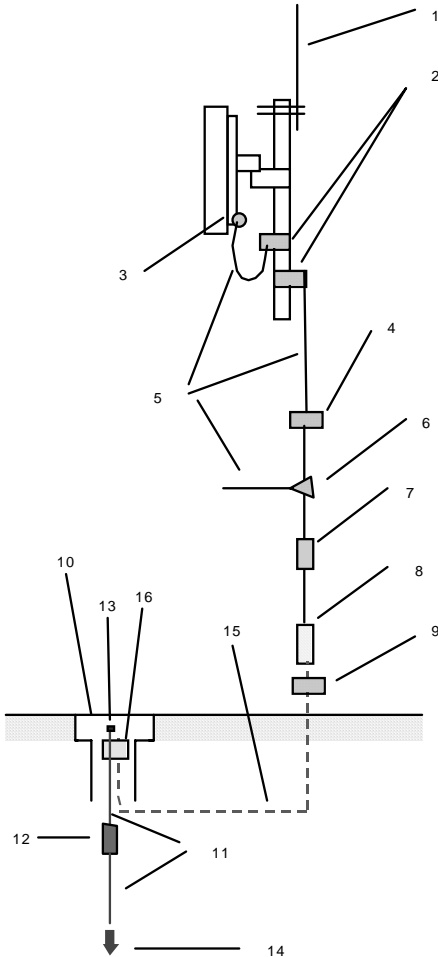

---

**Figure A-6 Example of a Tower LPS**

### References

1. *Earthing & Lightning Protection - Consultants Handbook* and the *Electronic Systems Protection Handbook*, published by WJ Furse & Co. Ltd (LPS hardware vendor).
2. *Recommendations for Lightning Protection, Electrical Supplies, and Earthing Systems at Radio Sites and Telecommunications Terminals*, compiled and written by D. Jackman and M.D. Palmer on behalf of South Western Electricity.
3. *Protection of Structures Against Lightning - British Standard BS 6651: 1992.*
4. *Grounding and Lightning Protection Guidelines*, 401-200-115.



---

## **Appendix B: Base Station (CU232) Installation Checklist**

# **B**

---

**THIS IS AN INCOMPLETE DRAFT.**

This appendix consists of a checklist for installing the base station equipment. A copy of this appendix should be made for each installation performed.



**NOTE:**

**READ THIS NOTE BEFORE USING THIS CHECKLIST -**

This checklist is intended for use by a qualified installer who has reviewed and understands all the procedures in this guide.

**Appendix B: Base Station (CU232)  
Installation Checklist**

**Base Station Equipment  
Installation Checklist**

The following information will be used during the installation process to complete the labels and paperwork.

Location ID  
(Base #): \_\_\_\_\_

Street: \_\_\_\_\_

City: \_\_\_\_\_

State: \_\_\_\_\_

Zip Code: \_\_\_\_\_

Floor #: \_\_\_\_\_

Lineup #: \_\_\_\_\_

Cabinet #: \_\_\_\_\_

| <b>BASE STATION PRE-INSTALLATION CHECKLIST-----PAGE 1 of 1</b> |  |                   |           |                 |                         |
|--|--|-------------------|-----------|-----------------|-------------------------|
| <b>INSTALLER:</b>  |  |                   |           |                 | <b>DATE:</b>            |
| <b>Item #</b>  | <b>WORK OPERATION</b>  | <b>DEVIATIONS</b> |           | <b>VERIFIED</b> | <b>Comment /Issue #</b> |
|  |  | <b>YES</b>        | <b>NO</b> |                 |                         |
| 2  | Verify the RF Plan.  |                   |           | o               |                         |
| 3  | Verify proper installation of the Ethernet and Frame Relay connection. |                   |           | o               |                         |
| 4  | Verify optional analog phone line connection for the modem.            |                   |           | o               |                         |
| 5  | Verify all the required hardware is available.                         |                   |           | o               |                         |
| 9  | Verify site Lightning Protection System (LPS).                         |                   |           | o               |                         |

**Appendix B: Base Station (CU232)  
Installation Checklist**

---

**CU232 Installation Checklist**

---

Base Station Name: \_\_\_\_\_

**CU232** Designation: \_\_\_\_\_

Base Station

Location: \_\_\_\_\_

\_\_\_\_\_

| Item | Work Operation   | YES | NO | Comments |
|------|--|-----|----|----------|
| 1    | Preferred method: An 8 mm diameter "schedule 40" poll is rigidly mounted to a wall at two locations. The supports are a maximum of 2 meters apart, and the pole is a maximum of 8 mm (3 in) from wall. |     |    |          |
| 2    | <b>CU232</b> mounting bracket is fastened to a poll with two U-bolts.  |     |    |          |
| 3    | Mounting bracket is adjusted in azimuth (horizontal) orientation per RF planning document and U-bolt hardware is tightened.  |     |    |          |
| 4    | Elevation (downtilt) of the mounting bracket is adjusted in accordance with the RF planning document and pivot bolts are tightened.  |     |    |          |
| 5    | The <b>CU232</b> serial number, azimuth (horizontal), and elevation (downtilt) are recorded.   |     |    |          |
| 6    | <b>CU232</b> is secured to mounting bracket.   |     |    |          |
| 7    | Integrity of power/data cable is verified.   |     |    |          |
| 8    | I/O plate is removed, power/data cable is inserted through water-tight fastener, and connections are properly made to plug-in terminal block.  |     |    |          |



## Appendix B: Base Station (CU232) Installation Checklist

---

| Item | Work Operation   | YES | NO | Comments |
|------|--|-----|----|----------|
| 9    | Plug-in terminal block is mated into contacts on the <b>CU232</b> circuit board. |     |    |          |
| 10   | I/O plate is fastened to <b>CU232</b> enclosure.                                 |     |    |          |
| 11   | Power/data cable is labeled identifying <b>CU232</b> number.                     |     |    |          |
| 12   | Power/data cable is clamped at regular intervals.                                |     |    |          |
| 13   | <b>CU232</b> is grounded.  |     |    |          |

# Appendix C: Site Preparation Grounding Checklist

# C

**THIS IS AN INCOMPLETE DRAFT.**

This appendix consists of a site preparation grounding checklist.

| Item | Description  | Yes<br>or<br>N/A | NO | Comment/<br>Issue # |
|------|--|------------------|----|---------------------|
|      | <b>Generally applicable to all types of Sites:</b>             |                  |    |                     |
| 1.   | Is the site resistance test on file?                           |                  |    |                     |
| 2.   | Is resistance $\leq 10\Omega$ ?                                |                  |    |                     |
| 3.   | If resistance is $> 10\Omega$ , has a waiver form been filed?  |                  |    |                     |
| 4.   | Have connections been provided to ground the electrode system? |                  |    |                     |
|      | If yes, check all that apply:                                  |                  |    |                     |
|      | Via a buried ring ground and driven rod(s)?                    |                  |    |                     |
|      | Via a buried metallic & electrical continuous water pipe?      |                  |    |                     |
|      | Via driven ground rod(s) and/or plates?                        |                  |    |                     |
|      | Via electrolytic ground rod(s)?                                |                  |    |                     |

## Appendix C: Site Preparation Grounding Checklist

| Item | Description   | Yes<br>or<br>N/A | NO | Comment/<br>Issue # |
|------|---|------------------|----|---------------------|
|      | Via grounded building steel?  |                  |    |                     |
|      | Via grounded grid or radial?  |                  |    |                     |
| 5.   | Is a lightning mast(s) or air terminal(s) provided?   |                  |    |                     |
|      | If yes, is lightning mast(s) bonded to Ground Electrode System?   |                  |    |                     |
| 6.   | Is <b>CU232</b> Support Structure(s) Grounded?  |                  |    |                     |
| 7.   | Are <b>CU232</b> cable shields grounded at both ends if tower is < 200 feet in height?  |                  |    |                     |
| 8.   | Are <b>CU232</b> cable shields grounded at both ends and mid-point if $\geq$ 200 feet in height?  |                  |    |                     |
| 9.   | Is <b>CU232</b> tower bonded to Ground Electrode System?  |                  |    |                     |
| 10.  | Are guy wires bonded to ground electrode system?  |                  |    |                     |
| 11.  | Are all ground connections according to Grounding & Lightning protection guidelines (Exothermic weld, compression type with long barrel 2 hole lugs, clamp-on and pressure type)? |                  |    |                     |

Inspector's Initials: \_\_\_\_\_ Date: \_\_\_\_\_ Page \_\_\_\_ of \_\_\_\_

## Appendix C: Site Preparation Grounding Checklist

| Item | Description   | Yes<br>or<br>N/A | NO | Comment<br>/Issue # |
|------|---|------------------|----|---------------------|
| 12.  | Are all ground connections properly secured and has an anti-oxidant been used on the contact area of all connections? |                  |    |                     |
| 13.  | Are grounding conductors routed as straight as possible with no loops or sharp bends (bending radius 12" minimum)?    |                  |    |                     |
| 14.  | Is supplementary ground conductor of proper type and gauge?   |                  |    |                     |
| 15.  | Please note size & type: _____<br>Is steel support structure/frame grounded?  |                  |    |                     |
| 16.  | Are all metallic conduits bonded at both ends and at 25' intervals?   |                  |    |                     |
| 17.  | Are all metallic objects within 6' bonded to the grounding system?  |                  |    |                     |
| 18.  | Is master ground bus insulated from mounting surface and is it mounted in proper location?                            |                  |    |                     |
| 19.  | Is AC Power Supply equipped with surge protection device and is device properly connected to the ground system?       |                  |    |                     |
| 21.  | Is Tower Light system equipped with surge protection device and is device properly connected to the ground system?    |                  |    |                     |

Inspector's Initials: \_\_\_\_\_ Date: \_\_\_\_\_ Page \_\_\_\_ of \_\_\_\_

## Appendix C: Site Preparation Grounding Checklist

---