

EXHIBIT 10: USERS MANUAL

§ 2.1033 Application for certification.

(c) Applications for equipment other than that operating under parts 15 and 18 of the rules shall be accompanied by a technical report containing the following information:

(3) A copy of the installation and operating instructions to be furnished the user. A draft copy of the instructions may be submitted if the actual document is not available. The actual document shall be furnished to the FCC when it becomes available.

Alcatel-Lucent
Remote Radio Head 2X60W - 850, 1900 MHz | UA08.1
Site Preparation
NN-20500-305
Issue 0.7; November 2011

Alcatel-Lucent – Proprietary
Use pursuant to applicable agreements

Legal notice

Alcatel, Lucent, Alcatel-Lucent and the Alcatel-Lucent logo are trademarks of Alcatel-Lucent. All other trademarks are the property of their respective owners.

The information presented is subject to change without notice. Alcatel-Lucent assumes no responsibility for inaccuracies contained herein.

Copyright © 2011 Alcatel-Lucent. All rights reserved.

Contains proprietary/trade secret information which is the property of Alcatel-Lucent and must not be made available to, or copied or used by anyone outside Alcatel-Lucent without its written authorization.

Not to be used or disclosed except in accordance with applicable agreements.



Alcatel-Lucent

Remote Radio Head 2X60W - 850, 1900 MHz | UA08.1

Site Preparation

Legal notice

Alcatel, Lucent, Alcatel-Lucent and the Alcatel-Lucent logo are trademarks of Alcatel-Lucent. All other trademarks are the property of their respective owners.

The information presented is subject to change without notice. Alcatel-Lucent assumes no responsibility for inaccuracies contained herein.

Copyright © 2011 Alcatel-Lucent. All rights reserved.

Contains proprietary/trade secret information which is the property of Alcatel-Lucent and must not be made available to, or copied or used by anyone outside Alcatel-Lucent without its written authorization.

Not to be used or disclosed except in accordance with applicable agreements.

2 Safety statements

Overview

Purpose

This chapter covers safety precautions.

Contents

| | |
|--------------------------------|-----|
| Structure of safety statements | 2-2 |
| Safety | 2-4 |
| Safety - specific hazards | 2-5 |
| Product safety | 2-8 |

Structure of safety statements

Overview

Safety statements describe the safety risks relevant while performing tasks on Alcatel-Lucent products during deployment and/or use. Failure to avoid the hazards may have serious consequences.

General structure

Safety statements include the following structural elements:

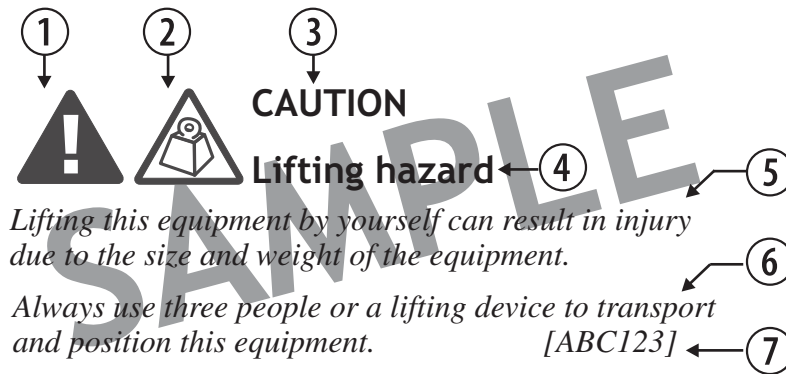

| Item | Structure element | Purpose |
|------|---------------------|--|
| 1 | Safety alert symbol | Indicates the potential for personal injury (optional) |
| 2 | Safety symbol | Indicates hazard type (optional) |
| 3 | Signal word | Indicates the severity of the hazard |
| 4 | Hazard type | Describes the source of the risk of damage or injury |
| 5 | Safety message | Consequences if protective measures fail |
| 6 | Avoidance message | Protective measures to take to avoid the hazard |
| 7 | Identifier | The reference ID of the safety statement (optional) |

Signal words

The signal words identify the hazard severity levels as follows:

| Signal word | Meaning |
|-------------|---|
| DANGER | Indicates an extremely hazardous situation which, if not avoided, will result in death or serious injury. |

| Signal word | Meaning |
|-------------|--|
| WARNING | Indicates a hazardous situation which, if not avoided, could result in death or serious injury. |
| CAUTION | Indicates a hazardous situation which, if not avoided, could result in minor or moderate injury. |
| NOTICE | Indicates a hazardous situation not related to personal injury. |

Safety

General precautions for installation procedures



WARNING

Failure to observe these safety precautions may result in personal injury or damage to equipment.

- *Read and understand all instructions.*
- *Follow all warnings and instructions marked on this product.*
- *Installation and maintenance procedures must be followed and performed by trained personnel only.*
- *The equipment must be provided with a readily accessible disconnect device as part of site preparation.*
- *Grounding and circuit continuity is vital for safe operation of the equipment. Never operate the equipment with grounding/bonding conductor disconnected.*
- *Install only equipment identified in the product's installation manual. Use of other equipment may result in an improper connection which could lead to fire or injury.*
- *Use caution when installing or modifying telecommunications lines.*
- *The product has multiple power inputs. Before servicing, Disconnect all inputs to reduce the risk of energy hazards.*
- *For continued protection against risk of fire, all fuses used in this product must be replaced only with fuses of the same type and rating.*
- *Never install telecommunications wiring during a lightning storm.*
- *Never install telecommunications connections in wet locations.*
- *Never touch uninsulated wiring or terminals carrying direct current or ringing current, and never leave this wiring exposed. Protect and tape uninsulated wiring and terminals to avoid risk of fire, electrical shock, and injury to personnel.*
- *Never spill liquids of any kind on the product.*
- *To reduce the risk of an electrical shock, do not disassemble the product. Opening and removing covers and/or circuit boards may expose you to dangerous voltages or other risks. Incorrect reassembly can cause electrical shock when the unit is subsequently used.*

Safety - specific hazards



Working in severe weather can result in personal injury or death and damage to the equipment.

Never install or perform maintenance during severe weather (high winds, lightning, blizzards, hurricane etc.).



Use of unspecified cleaning agents can result in personal injury.

Use only specified cleaning agents. Never use flammable solvents.

Always ensure there is adequate ventilation in the work area and wear the appropriate personal protective equipment.



This equipment operates with invisible laser radiation. Laser radiation can cause considerable injuries to the eyes.

Never look into the end of an exposed fiber or into an open optical connector when the optical source is switched on. Always observe the laser warning instructions.



Some parts of all electrical installations are energized. Failure to observe this fact and the safety warnings may lead to bodily injury and property damage.

For this reason, only trained and qualified personnel (electrical workers as defined in IEC 60215 + A1 or EN 60215) may install or service the installation.



The power supply lines to the network element are energized. Contact with parts carrying voltage can cause health problems, possibly including death, even hours after the event.

Open and lockout the load disconnect switch in the distribution box to completely de-energize the network element.

**WARNING****Laser hazard**

The light from laser and high-radiance LED's may cause eye damage if absorbed by the retina.

In the US consult ANSI Z136.2, in Europe consult IEC-60825 Safety of laser products, for guidance on the safe use of optical fiber communication systems in the workplace.

**NOTICE****ESD hazard**

Semiconductor devices can be damaged by electrostatic discharges.

The following rules must be complied with when handling any module containing semiconductor components:

- *Wear conductive or antistatic working clothes (for example, coat made of 100% cotton).*
- *Wear the grounded wrist strap.*
- *Wear shoes with conductive soles on a conductive floor surface or conductive work mat.*
- *Leave the modules in their original packaging until ready for use.*
- *Make sure there is no difference in potential between yourself, the workplace, and the packaging before removing, unpacking, or packing a module.*
- *Hold the module only by the grip without touching the connection pins, tracks, or components.*
- *Place modules removed from the equipment on a conductive surface.*
- *Test or handle the module only with grounded tools on grounded equipment.*
- *Handle defective modules exactly like new ones to avoid causing further damage.*

NOTICE**Condensation**

Sudden changes in the weather may lead to the formation of condensation on components. Operating the unit when condensation moisture is present can destroy the unit.

Units which show signs of condensation must be dried before installation.



The cabinet and the components within may have sharp edges and burrs and contact may cause cuts and lacerations.

Beware of sharp edges and burrs, especially when working on areas inside the cabinet difficult to access.

Wear appropriate personal protective equipment.

NOTICE

Tools

Tools left in the working area can cause short circuits during operation which can lead to the destruction of units.

Make sure after finishing your work that no tools, testing equipment, flashlights, etc., have been left in or on the equipment.



Cleaning plastic containers and lids with abrasive and aggressive cleaning agents may cause permanent damage.

Do not use solvents, paraffin, abrasive or aggressive cleaning fluids, abrasive or aggressive antiseptic agents or abrasive or aggressive materials.



Cleaning with water or a high-pressure cleaner will damage the components in the cabinet.

The washing down of the equipment or cabinet with water or a high-pressure cleaner is not permitted.



Lifting this equipment by yourself can result in injury due to the size and weight of the equipment.

Always use at least two people or a lifting device to move or position this equipment.

Product safety

Equipment safety

Safety information for this equipment can be found on various Caution, Warning, Danger, information labels or instructions affixed to or included with the enclosure, its internal assemblies or included within this document. Informational and cautionary labels may appear near the item they address or may be grouped in a single location on the equipment. Warnings are typically adjacent to the hazard that is noted on the label. The instructions, cautions and warnings found on these labels must be understood and observed by all personnel involved with the equipment installation and maintenance.

3 Product overview

Overview

Purpose

This chapter provides an overview of the Alcatel-Lucent Remote Radio Heads:

- RRH 2X60-850
- RRH 2X60-1900

Contents

| | |
|------------------------|------|
| Functional description | 3-2 |
| Physical description | 3-4 |
| Equipment | 3-12 |
| Mounting locations | 3-13 |

Functional description

General description

The Alcatel-Lucent Remote Radio Head 2X60W product is the latest generation of UMTS cell site equipment.

Product configurations

The standard configuration offers:

- For the 9396 d2U a maximum of three sectors per Base Band Unit (BBU)
- For the 9326 / 9926 d2U a maximum of six sectors per Base Band Unit (BBU)

Product capabilities

The product capabilities in this release are:

- DC power supply variant: – 48V (– 40V to – 57V)
- RF output power @ antenna port : 2X60W (47.8dBm) at antenna connector, shared across transmitted carriers.
- Operating radio frequency:
 - 850 MHz for the RRH 2X60-850
Band V, 3GPP TS25.104
 - 1900 MHz for the RRH 2X60-1900
Band II, 3GPP TS25.104
- Number of carriers: up to four adjacent carriers (20 MHz) per antenna
- One sector
- 2 antennae
- 4 antennae (future release)
- Daisy chaining for RRHs operating in single carrier mode
- User alarms

| External user alarms | |
|----------------------|---------------|
| RRH 2X60-850 | RRH 2X60-1900 |
| 6 | 6 |

- Mounting standard configuration:
 - Pole
 - Wall
 - Floorstand
- Front access installation and service
- Bottom I/O panel access
- Single or twin Antenna Line Device (ALD) compliant with AISG V2.0

- Rx AIT
- CPRI ports/Rates: 2 / HW ready 3,4,5

External view

This is a view of an RRH 2X60W with 2 antenna connections:

2 antenna connectors

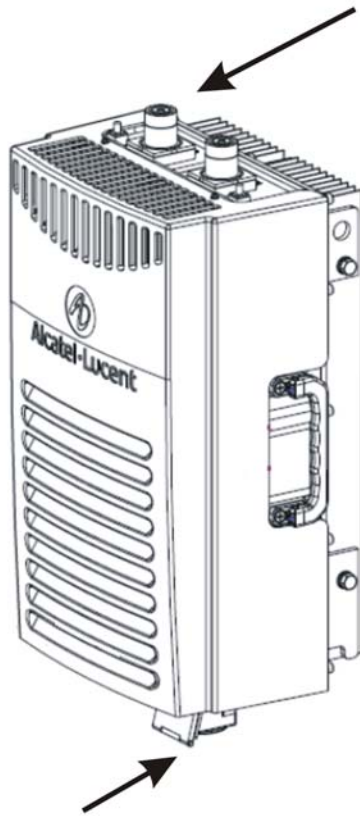

Power connector

Physical description

Overview

This topic covers RRH top and bottom descriptions, ancillary and grounding information.

Cable interfaces

On the RRH bulkhead the following cable interface points are found:

- DC power
- Fiber optic
- User alarms
- Antenna Line Device
- Local Maintenance Terminal port (LMT)
- RF
- Ground

The top of the RRH allows access for connecting RF cables.

Bottom view of the RRH

Bottom view of the RRH 2X60W-850:

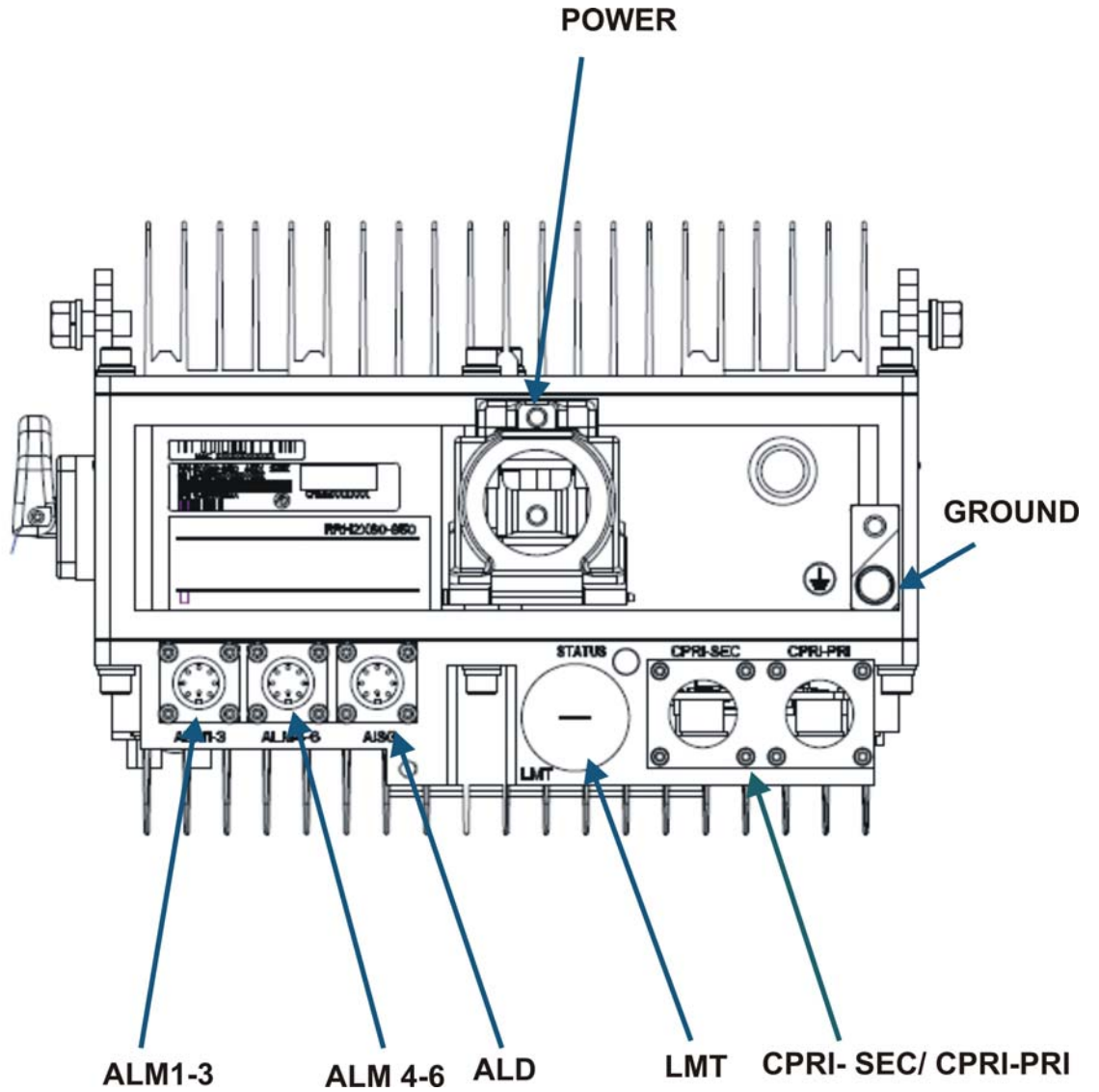

Bottom view of the RRH 2X60W-1900:

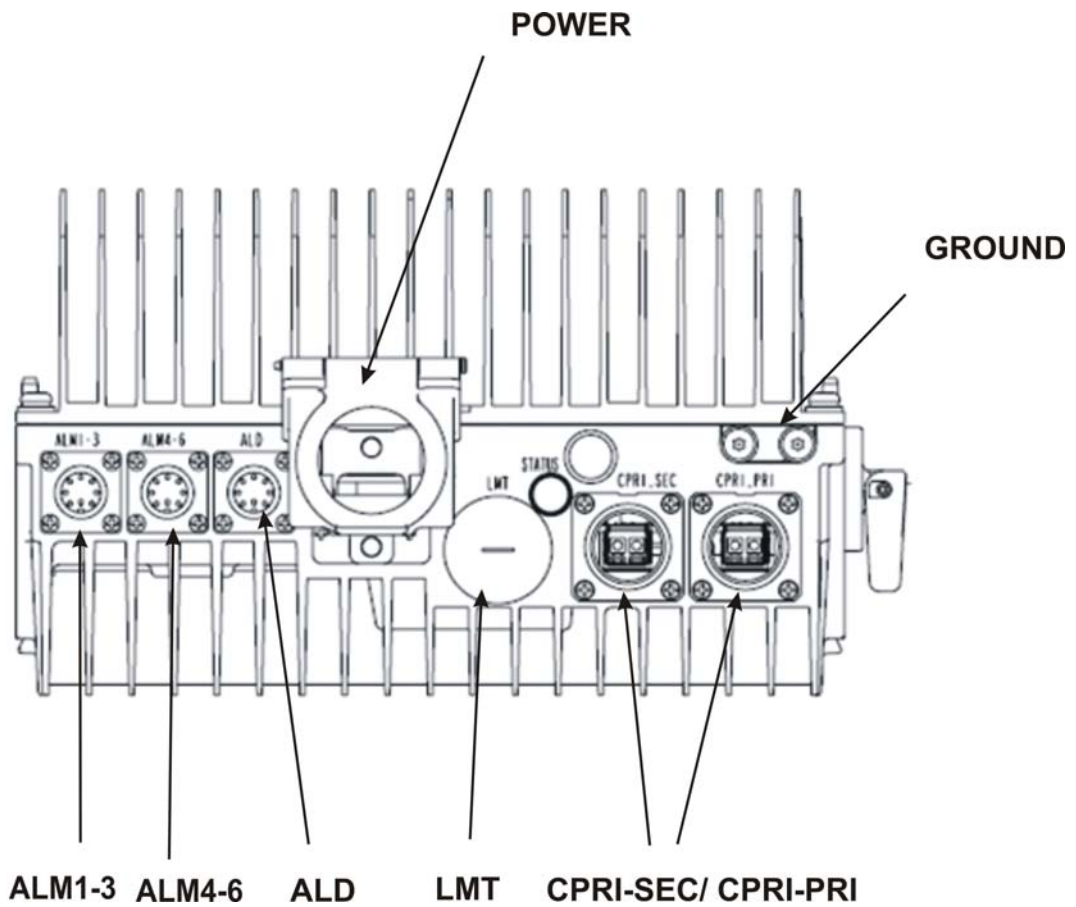

For details on the RRH connectors refer to [“RRH connectors”](#) (p. 3-8).

Top view of the RRH

Top view of the RRH 2X60W-850:

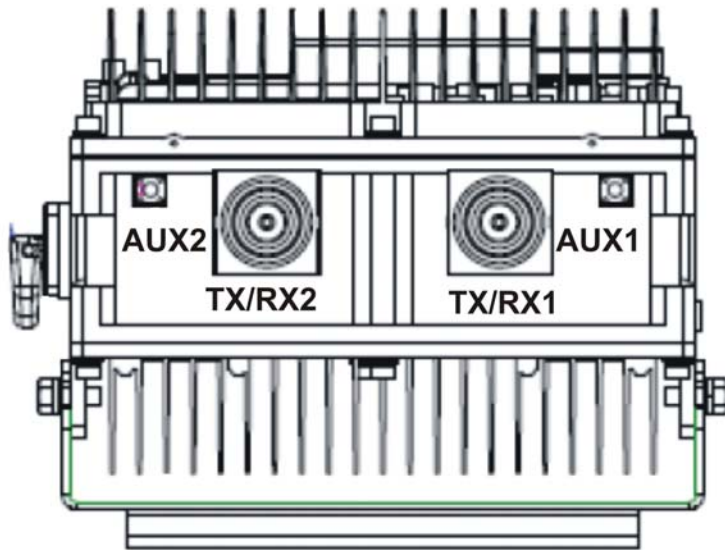

Top view of the RRH 2X60W-1900:

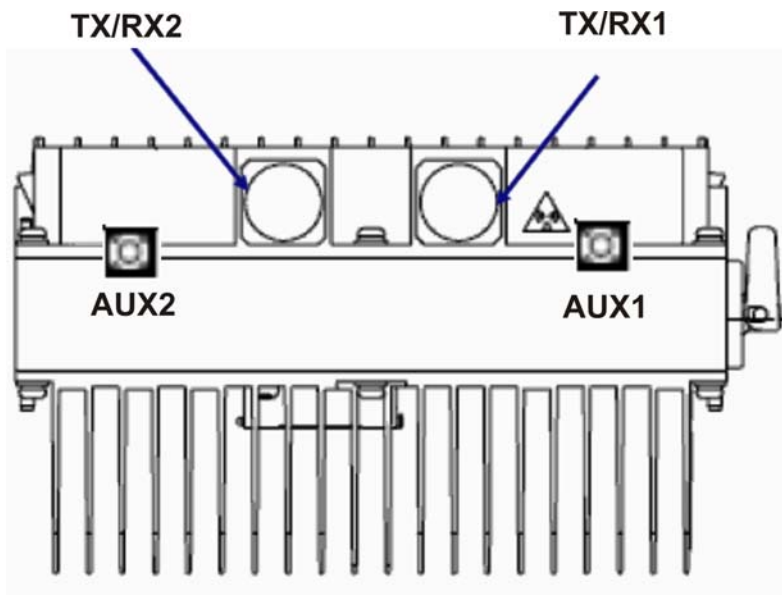

RRH connectors

Description of the connectors present on the bulkhead:

| Connector | Function |
|--------------------------------|---|
| EAC Rx | Receive diversity antenna path 7/16 DIN coaxial female connector for the connection with the diversity antenna |
| EAC Tx/Rx | Transmit and receive antenna path 7/16 DIN coaxial female connector for the connection with the antenna |
| GND | Ground connection |
| ALD (Antenna Line Device) | Antenna power and control 1 AISG (RS485) connector 8-pin Circular Din female connector Support of RETA compatible with AISG 2.0. |
| CPRI_PRI | CPRI optical port Used to connect the RRH to the Node B SFP, with waterproof Radiall flange connector (which includes the protective metal cover) |
| CPRI_SEC | CPRI optical daisy-chained port Used to connect to the other RRH in daisy chain configuration SFP, with waterproof Radiall flange connector (which includes the protective metal cover) |
| User Alarms (ALM 1-3, ALM 4-6) | 6 user alarms for both RRH 2X60-850 and RRH 2X60-1900 Implemented with 2 X 8-pin circular DIN female connectors (same as AISG). |
| DC Power | -48 V DC Up to 8 AWG |
| AUX Rx | 2 AUX Rx ports (AUX_RX1, AUX_RX2), located on the top of the RRH 2X60-850 and 1900. |
| LMT | Local maintenance terminal (LMT) RJ45 connector located on the bottom of the RRH 2X60-850 and 1900 |

Note: A reset button is located next to the LMT port

Ancillary support of RRH 2X60-850 and RRH 2X60-1900

| RRH 2X60-xx ancillary | | |
|-------------------------------|--|---|
| Item | Quantity | Comments |
| Power cable without connector | 1 | Different cable lengths (RRH 2X60-850 or 1900) 12 AWG, 10 AWG or 8 AWG power cable pair |
| Ground cable | 1 | 16 m Length Ground cable is mandatory for the RRH installation. |
| Grounding kit | 1 | Optional |
| Alarm cable | 1 or 2 | 15 m or 30 m length. One cable supports 3 user alarms. Cable, alarm connectorized 4 pair Optional |
| SFP optical transceiver | One SFP per RRH 2X60W in star configuration Two SFP per RRH 2X60W in daisy chain configuration except on the last RRH 2X60W of the chain. | Optical transceiver for multi-mode, dual fiber Optical transceiver for single-mode, single fiber Optical transceiver for single-mode, dual fiber |
| Optical cable | Depends on configuration | Several variants according to site cabling Optical fiber type <ul style="list-style-type: none"> • LC-LC Single-mode, dual fiber • LC to LC Single Mode Single fiber • LC to LC Multi Mode Dual fiber Optical connection: LC-LC |
| R2CT kit | 1 | Per optical connector used Several variants according to site cabling This kit is used to waterproof the optical connection. It's not necessary if the RRH 2X60W is installed indoor. Optional |

| RRH 2X60-xx ancillary | | |
|-----------------------|--------------------------|--|
| Item | Quantity | Comments |
| TMA | 1 | AISG 2.0 connection: Standard 8 pin circular Optional |
| TMA connection kit | 1 | Optional |
| RF Jumpers | 2, 4 | Per sector |
| Mounting Kit | 1 Wall mounting bracket | Standard Wall mounting is mandatory per RRH 2X60W whatever the mounting kit used. |
| | 1 Pole mounting bracket | Standard Optional |
| | 1 Floor mounting bracket | Standard Optional |

Ground location

Ground connections are located on both, the top and the bottom of the enclosure's left side. In the figure the side of the RRH enclosure is shown.

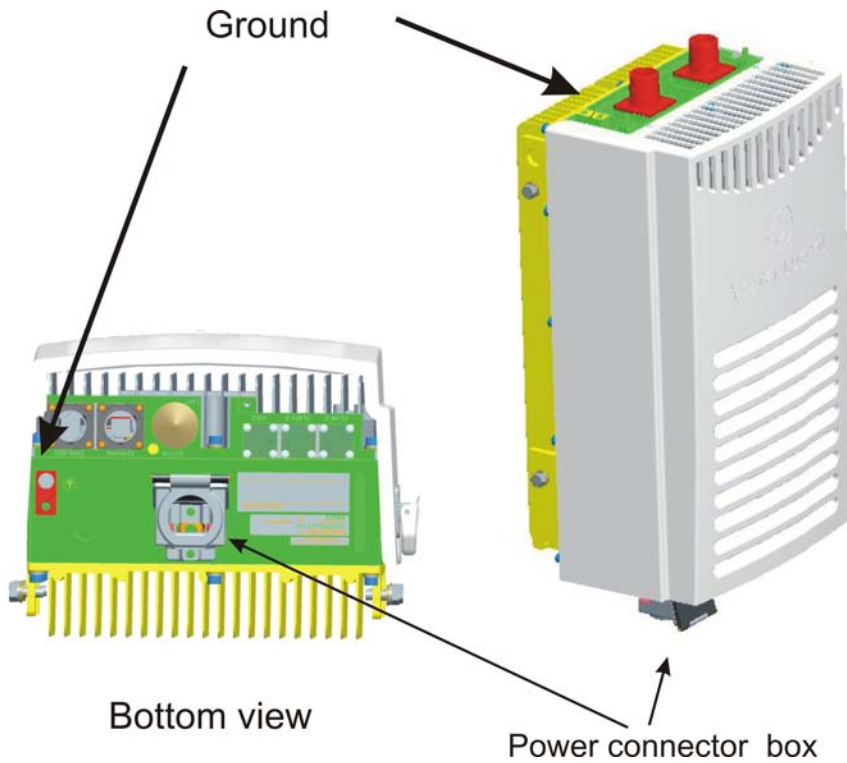

The ground cable is connected to the RRH with M6 screw and cable with a simple or double lug.

Equipment

Physical features

This topic covers the RRH weights and dimensions.

Weights and dimensions

The following table provides RRH weights and dimensions.

| Features | RRH 2X60-850 | RRH 2X60-1900 |
|--|-----------------|-----------------|
| Size with DC solar cover | 2 antennae | 2 antennae |
| HxWxD mm | 470 x 285 x 225 | 510 x 285 x 180 |
| Volume l | 30 | 26 |
| Weight with solar shield kg | 22 | 18 |

Miscellaneous hardware weights

The following table provides approximate weights for batteries and other miscellaneous hardware.

| Item | Weight kg (lb.) |
|------------------------------|-----------------|
| Wall bracket (RRH) | 4.1 (9) |
| Pole brackets (2) (standard) | 2.73 (6) |
| Pole Bands (2) | 1.8 (4) |
| Pole Bracket (Low Profile) | 1.8 (4) |
| Floorstand (RRH) | 11 (24.2) |

Mounting locations

Mounting configurations

The RRH can be mounted in three standard configurations:

- Pole-mounted (using either pole bands or through bolts)
- Wall-mounted
- Floorstand-mounted.

Pole mounting

The following diagram shows an RRH 2X60W mounted with standard weldments and bands to a pole:

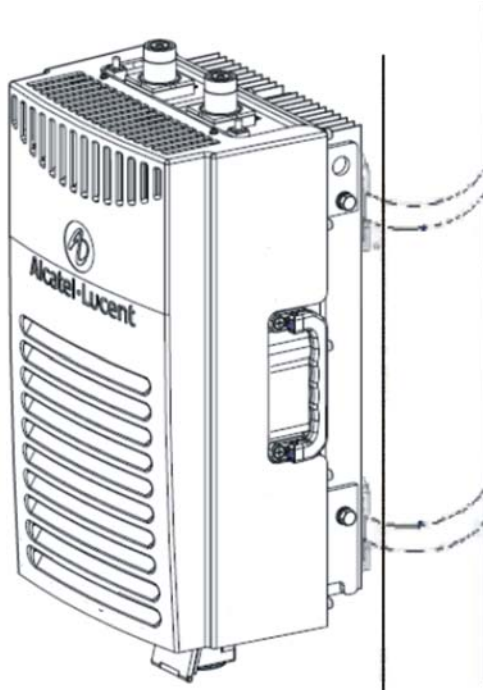

Wall mounting

The following diagram shows an example of RRH 2X60W mounted to a wall using a pole mount standard profile:

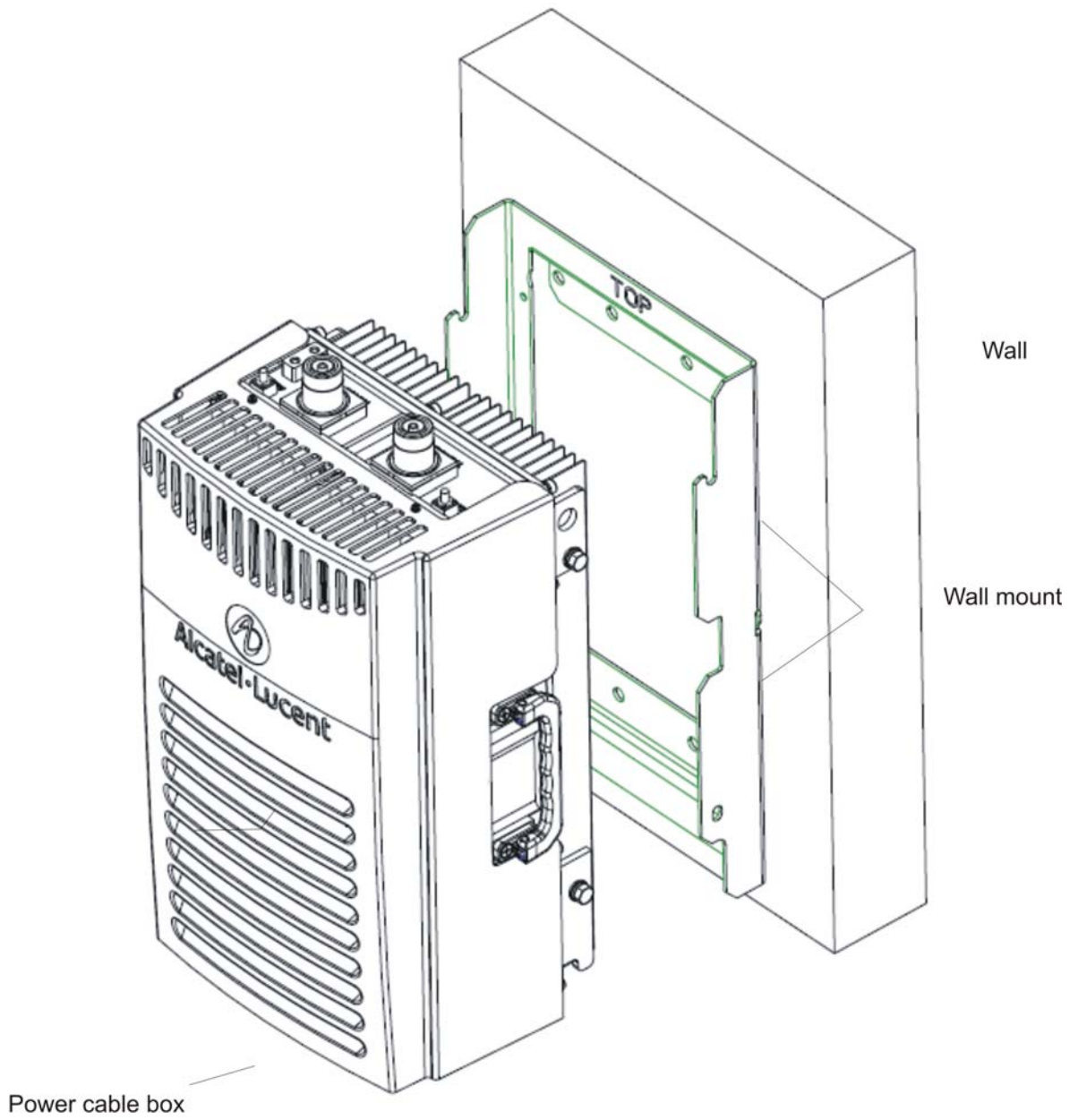

Floor stand

The following diagram shows a floor stand mounted RRH 2X60W:

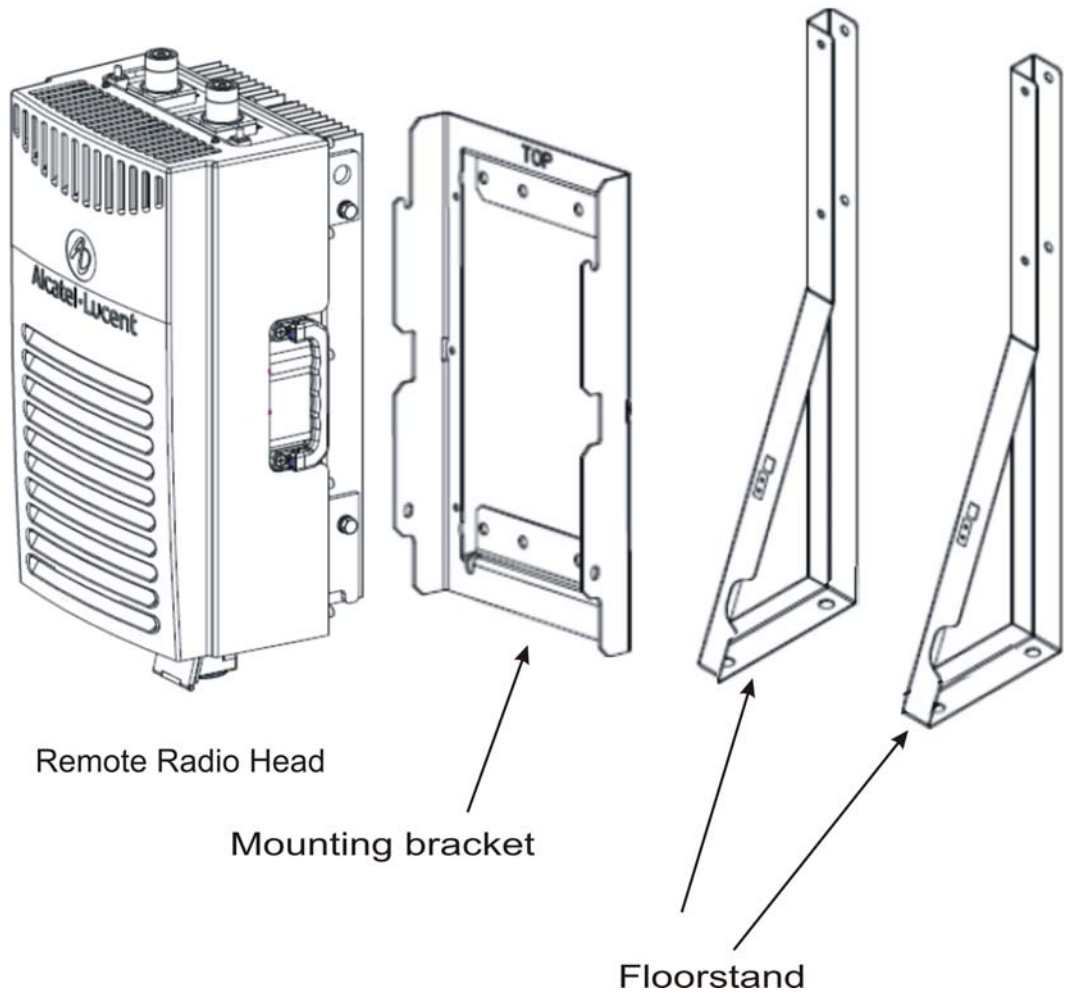

4 Site configurations

Overview

Purpose

This chapter provides information about the RRH 2X60W radio and CPRI configurations.

Contents

| | |
|-------------------------------------|-----|
| RF configurations | 4-2 |
| CPRI configurations | 4-3 |

RF configurations

Physical RF connections

The RF capacity is measured in sectors, carriers, and RF signal power. The RF capacity determines what components appear in the RRH and what antenna connections are required.

The base station can be connected to RRHs of the following RF frequency:

- UMTS 850 MHz using the RRH 2X60-850
- UMTS 1900 MHz using the RRH 2X60-1900

The RRH accepts connections for:

- Two or four (future release) RF antenna cables with 7-16 DIN coaxial female connectors

RF configurations

The following configurations are supported.

| Configuration | RF connectors (per sector) | RF signal power per carrier (nominal) |
|----------------------------------|----------------------------|---------------------------------------|
| UMTS 850, 1900 MHz | 2 | 60 W |
| UMTS 850, 1900 MHz multi carrier | 4 | |
| | with antenna sharing: 2 | |

CPRI configurations

Star or Daisy Chain solution

The solution is a distributed architecture composed of two optical interfaces located in:

- The digital NodeB
- The RRH

The optical modules are connected by optical fibers that carry:

- Downlink and uplink base band digital signals
- OAM information

The daisy chain allows to connect RRHs on one single optical link connected to the digital Node B part.

In the star configuration the BBU is the central node that provides the common connection point for all connected RRHs.

This figure shows the star and daisy chain configuration:

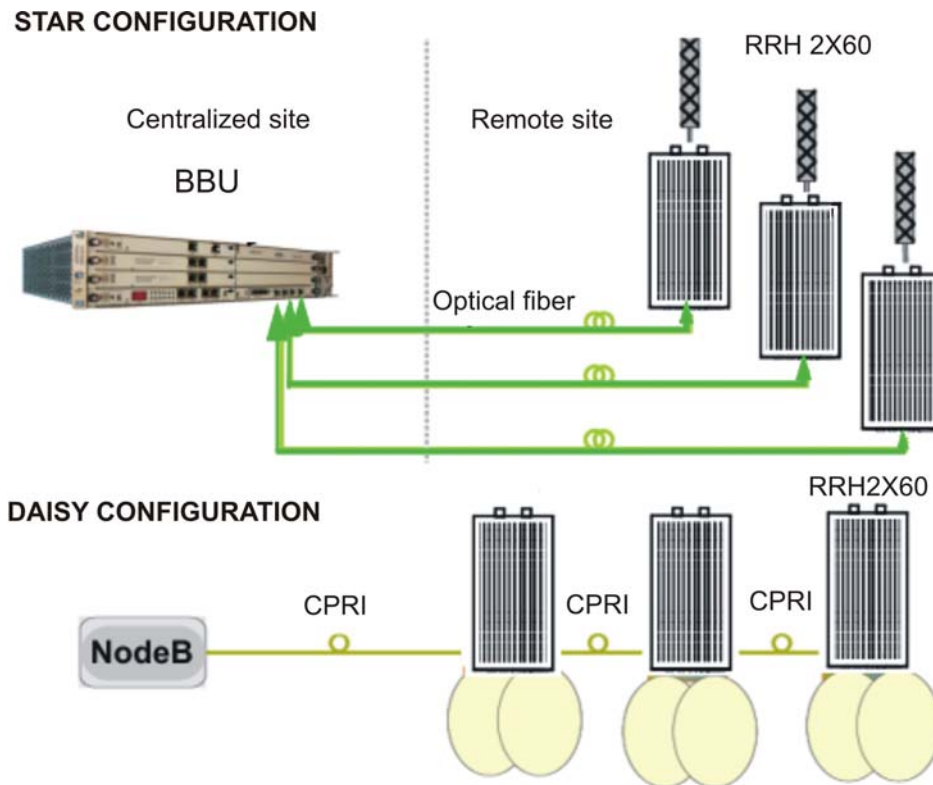

Different capabilities and configurations are supported, depending on whether the RRH 2X60W is connected to a 9396 d2U or to a 9926 d2U.

For RRH 2X60W on 9396 d2U, the configuration that is supported is the star configuration with single frequency on the first Power Amplifier (PA 1).

For the 9926 d2U the second Tx path is enabled. With six CPRI ports available, many configurations are possible, the main ones are:

- 6 RRHs in STSR2 (two frequencies on PA 1) in star configuration
- 3 RRHs in STSR4 (four frequencies on PA 1) in star configuration
- 2 X 3 RRHs in STSR2 (two fibers of three RRHs each with two frequencies on PA 1) using daisy-chain configuration
- 3 X 2 RRHs in STSR2 (three fibers of two RRHs each with two frequencies on PA 1) using daisy-chain configuration
- 6 RRHs in STSR1+1 (two fibers of three RRHs each with one frequency on PA 1; one frequency on second Power Amplifier (PA 2)) in star configuration
- 2 X 3 RRHs in STSR1+1 (two fibers of three RRHs each with one frequency on PA 1; one frequency on PA 2) using daisy-chain configuration
- 3 X 2 RRHs in STSR1+1 (three fibers of two RRHs each with one frequency on PA 1; one frequency on PA 2) using daisy-chain configuration
- 3 RRHs in STSR2+2 (two frequencies on PA1; two frequencies on PA 2) in star configuration

Other supported configurations for the RRH 2X60W and 9926 d2U include either depopulated variations of the above (including STSR3, STSR2+1), or mixed configurations using 2 clusters (the first 3 fiber connections are considered cluster 1, and the second 3 fiber connections are considered cluster 2). Dual band 850/1900 configurations are also possible using 1 band per cluster. The possible dual band configurations for RRH 2X60W and 9926 d2U include:

- 6 RRHs in STSR2 (two frequencies on PA 1) in star configuration, with cluster 1 = Band A and cluster 2 = Band B
- 2 X 3 RRHs in STSR2 (two fibers of three RRHs each with two frequencies on PA 1) using daisy-chain configuration, with fiber 1 (on cluster 1) = Band A and fiber 4 (on cluster 2) = Band B
- 3 X 2 RRHs in STSR2 (three fibers of two RRHs each with two frequencies on PA 1) using daisy-chain configuration, with the first RRH on each fiber = Band A and the second RRH on each fiber = Band B
- 6 RRHs in STSR1+1 (two fibers of three RRHs each with one frequency on PA 1; one frequency on PA 2) in star configuration, with cluster 1 = Band A and cluster 2 = Band B
- 2 X 3 RRHs in STSR1+1 (two fibers of three RRHs each with one frequency on PA 1; one frequency on PA 2) using daisy-chain configuration, with fiber 1 (on cluster 1) = Band A and fiber 4 (on cluster 2) = Band B
- 3 X 2 RRHs in STSR1+1 (three fibers of two RRHs each with one frequency on PA 1; one frequency on PA 2) using daisy-chain configuration, with the first RRH on each fiber = Band A and the second RRH on each fiber = Band B

Note: For more details refer to the RRH Product Engineering Information document (Related information).

5 Site requirements

Overview

Purpose

This chapter describes the site requirements for the following RRHs:

- RRH 2X60-850
- RRH 2X60-1900

Contents

| | |
|---|------|
| Environmental requirements | 5-2 |
| General site requirements | 5-3 |
| RRH clearances | 5-4 |
| Site requirements for pole mount installations | 5-5 |
| Site requirements for wall mount installations | 5-9 |
| Site requirements for floor stand installations | 5-13 |

Environmental requirements

Outdoor environment

The outdoor RRH is weather-hardened, which enables it to operate in environments within the conditions described in the following table.

| Condition | Specification |
|------------------------|--|
| Manufacturing | Manufactured according to the WEEE (Waste of Electrical and Electronic Equipment) and RoHS (Restriction of Hazardous Substances) recommendations |
| Operating temperature | -40 to +50 °C (+55 °C with optional solar shields) |
| Absolute humidity | 0.03 g/m ³ to 36 g/m ³ |
| Relative humidity | 5 to 100% (non-condensing but not to exceed 0.024 kg water/kg of dry air) |
| Acoustic noise | No noise generated (no fan, natural convection cooling) |
| Operating altitude | Up to 15,000 feet where the maximum ambient temperature decreased by 0.5 degrees C per 1,000 feet above sea level |
| Enclosure rating | Type 4 (NEMA) IP55 (IEC 60529) |
| Wind driven rain | Refer to Telcordia GR-487-CORE |
| Dust and water ingress | Weather resistant to prevent ingress of rain, snow, dust and other solid foreign objects to a minimum level of IP65. The corrosion requirements is over the 15 years lifetime. Refer to Telcordia GR-487-CORE |
| Firearms resistance | Refer to Telcordia GR-487-CORE |
| Wind resistance | Refer to Telcordia GR-487-CORE |
| Storage requirements | Refer to Telcordia GR-63-CORE, Section 4.1.1 |

RRH heat dissipation (maximum)

The following table provides the estimated typical and the maximum heat dissipation information for the RRH.

| RRH | Estimated DC heat dissipation (typical value) | Estimated DC heat dissipation (maximum value). |
|---------------|---|--|
| RRH 2X60-850 | 305 W | 340 W |
| RRH 2X60-1900 | 300 W | 380 W |

General site requirements

General requirements

The following general requirements must be met before the installation of the RRH can begin:

- Adequate clearance must be provided for service access.
- Electric service must be installed as described in Appendix C “Electrical power requirements”.
- Back haul and user alarm facilities must be installed as described in [Chapter 9, “User alarm, and fiber optic requirements”](#).
- Grounding electrode system must be installed.
- RF antenna runs must be installed (if required).
- Tower light power must be installed (if required).
- Tower light alarm must be installed (if required).
- Mounting bracket holes must be drilled.
- The environment must comply with limits listed in [“Environmental requirements” \(p. 5-2\)](#).
- Cable supports and racks must be installed.

Cable support and racks

All RF cable runs, power cable runs, and facilities cable runs must be supported by a cable support and rack system.

The according cable conduits must be provided.

Structural requirements

Pole, wall loading, and wind must be considered during site preparation.

In some cases, cell site equipment may not be mounted directly to the wall without plate or strut to properly distribute the load.

The support structure must be designed in compliance with national building codes and all other applicable codes.

RRH clearances

Minimum clearances table

The following table provides the minimum wall mount clearances recommended around the RRH.

| RRH | Clearances mm (inches) | Comments |
|----------------|------------------------|---|
| Front | 1000 (39.37) | Installation access |
| Rear | 70 (2.76) | Zero rear clearance is allowed using supplied mounting brackets. |
| Side clearance | 300 (11.81) | Air flow To secure RRH body on the mounting kit To change the shield cover. |
| Top | 300 (11.81) | Air flow |
| Bottom | 500 (19.67) | Conduit routing |

Minimum clearances graphics for RRH

The following graphic is an example of minimum clearances between RRHs.

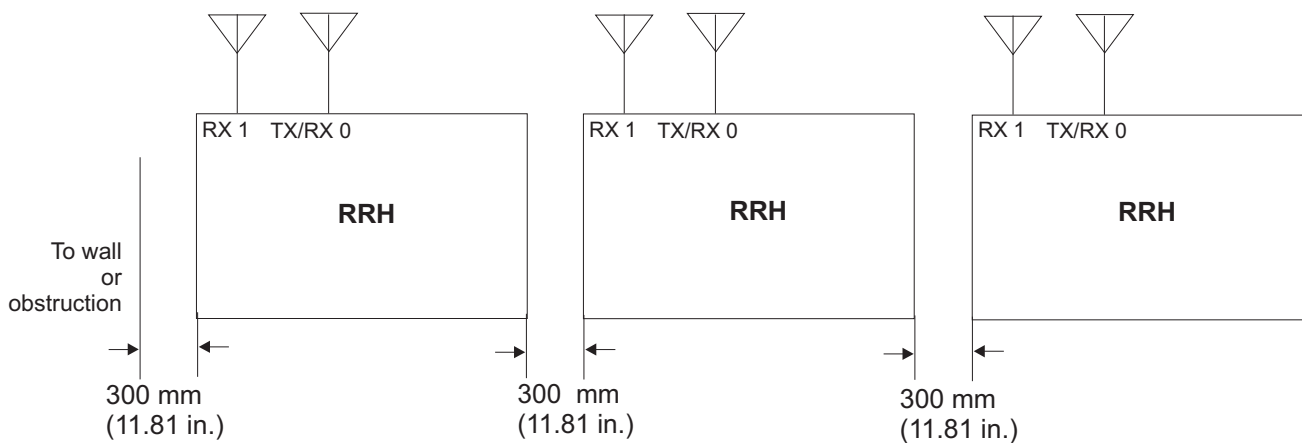

Site requirements for pole mount installations

Prepare site for pole mounting installation

The following are required to prepare a site for pole mounting installation of the RRH.

- Install power runs
- Install grounding system
- Install back haul runs
- Install RF runs
- Install user alarm runs
- Mark on the pole where the top of the pole bracket would be located

Pole mounting installation requirements

The following table provides the requirements for the different types of pole weldment.

| Weldment Type | Standoff mm (inches) | Application | Pole diameter mm |
|------------------------------|----------------------|--|------------------|
| Standard weldment | 118 (4.6) | Multiple RRHs installation at the same elevation | 152 - 380 |
| Low profile small pole mount | 40 (1.6) | Single RRH installation | 50 - 152 |

The following figure shows the type of weldments required for a pole mount installation. The standard pole weldments are used for multiple RRH installations.

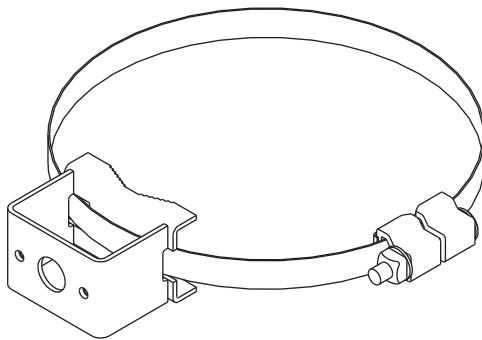

Pole band with standard weldment

Centerline distance between pole mount brackets shall be 350 mm (13.78 in) for the RRH.

The following graphic shows the pole brackets needed for small diameter poles.

The grip ranges for pole bracket of :

- 85 mm is: 51 mm to 150 mm.
- 50 mm is: 50 mm to 150 mm.

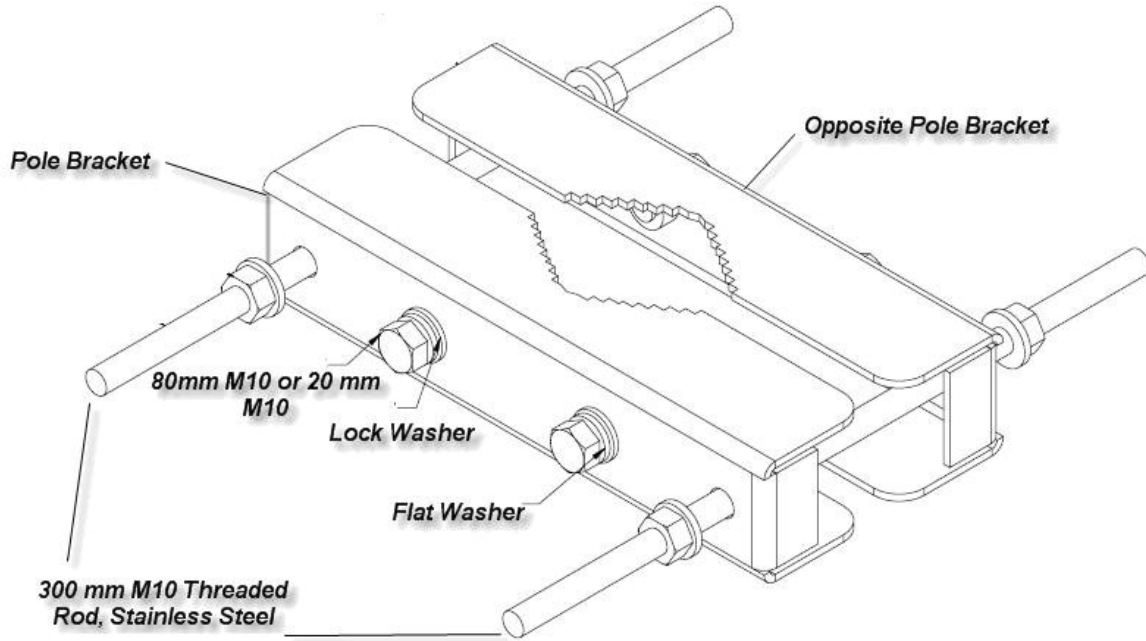

Drill pattern for through pole bolts

Drill pattern for pole mounting

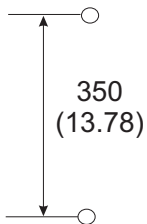

Pole mounting installation

The following graphic shows the pole mounting installation:

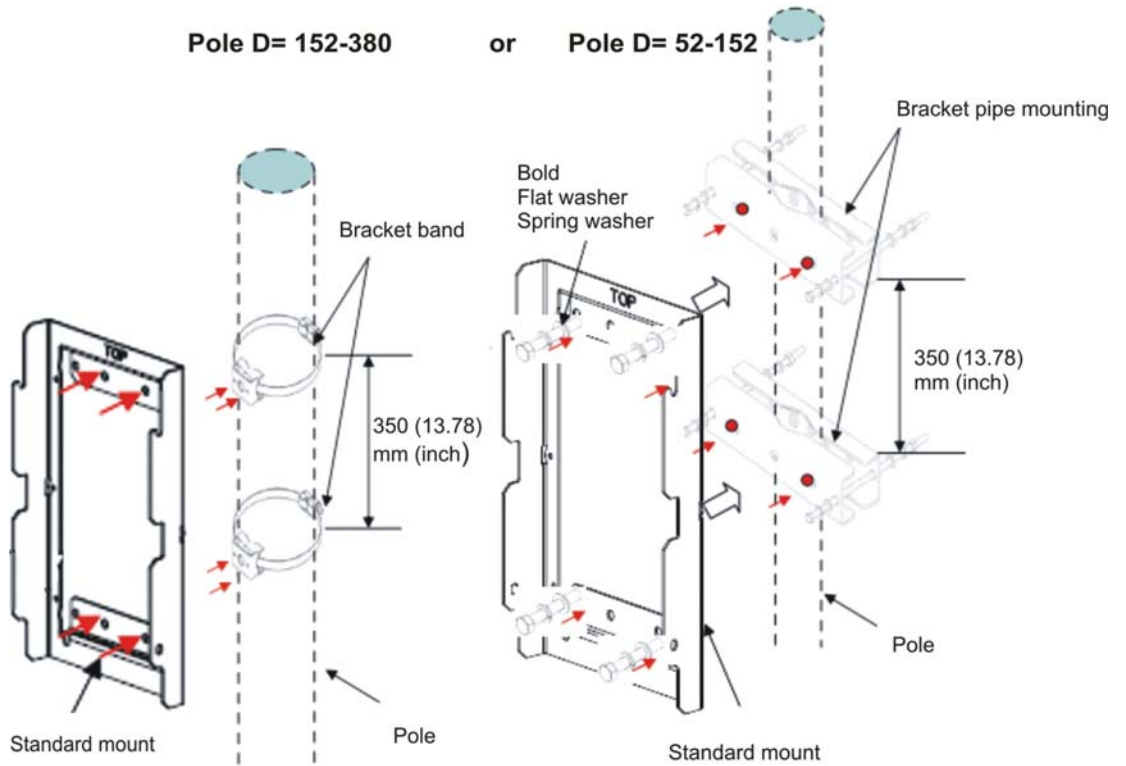

Example for pole mounting

RRH mounted with standard weldments:

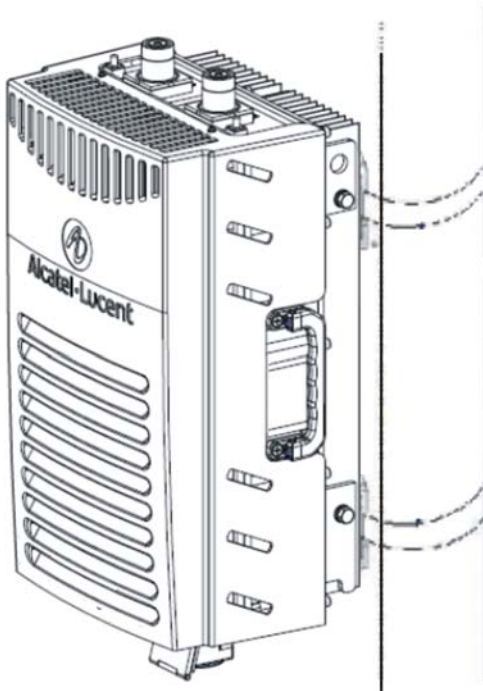

Site requirements for wall mount installations

Overview

This topic describes site requirements for RRH installation on a wall.

Prepare site for wall mount installation

The following are required to prepare a site for wall mount installation of the RRH.

- Install DC power runs
- Install grounding system
- Install Back haul
- Install RF runs
- Install user alarm runs

Wall mounting shall comply with the applicable architectural codes listed on listed earlier in this chapter.

Holes shall be pre-drilled with (customer supplied) anchor hardware, if mounting to a concrete wall.

Unistrut shall be in place, if required for mounting RRH.

RRH wall mounting hardware

The following is an example of customer-supplied mounting hardware that is required to mount struts to a solid concrete wall:

- 1.5" x 1.5" Unistrut® or equivalent struts (2)
- M10 (3/8") x 100 mm (4") long Power-Stud™ (formerly called Rawl-Stud®) or equivalent anchor bolts for solid concrete walls (4)
- M10 (3/8") nuts (4)
- M10 (3/8") flat washers (8)
- M10 (3/8") spring nuts from the same manufacturer as the struts (4)
- M10 (3/8") x 25 mm (1") long hex-head bolts (4)
- M10 (3/8") lock washers (4).

Wall mount brackets mounting holes

The following figure shows the drill pattern for the wall mounting bracket holes.

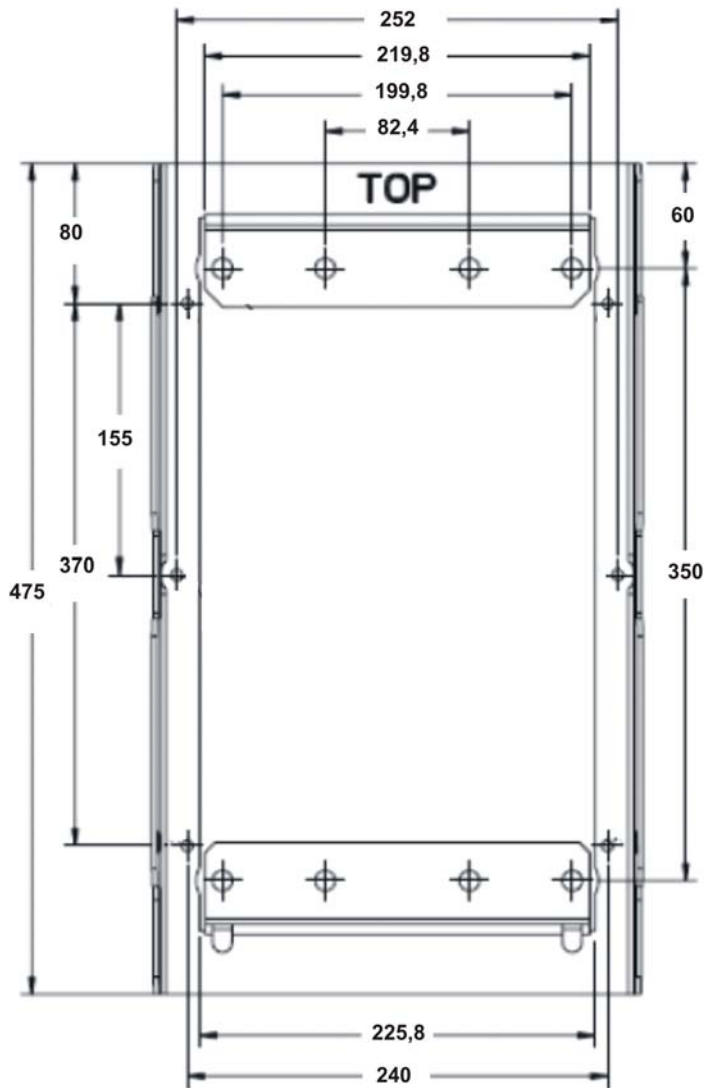

Strut mounting hardware

The following photo illustrates the hardware that is required to mount a strut on a concrete wall and the RRH to the strut.

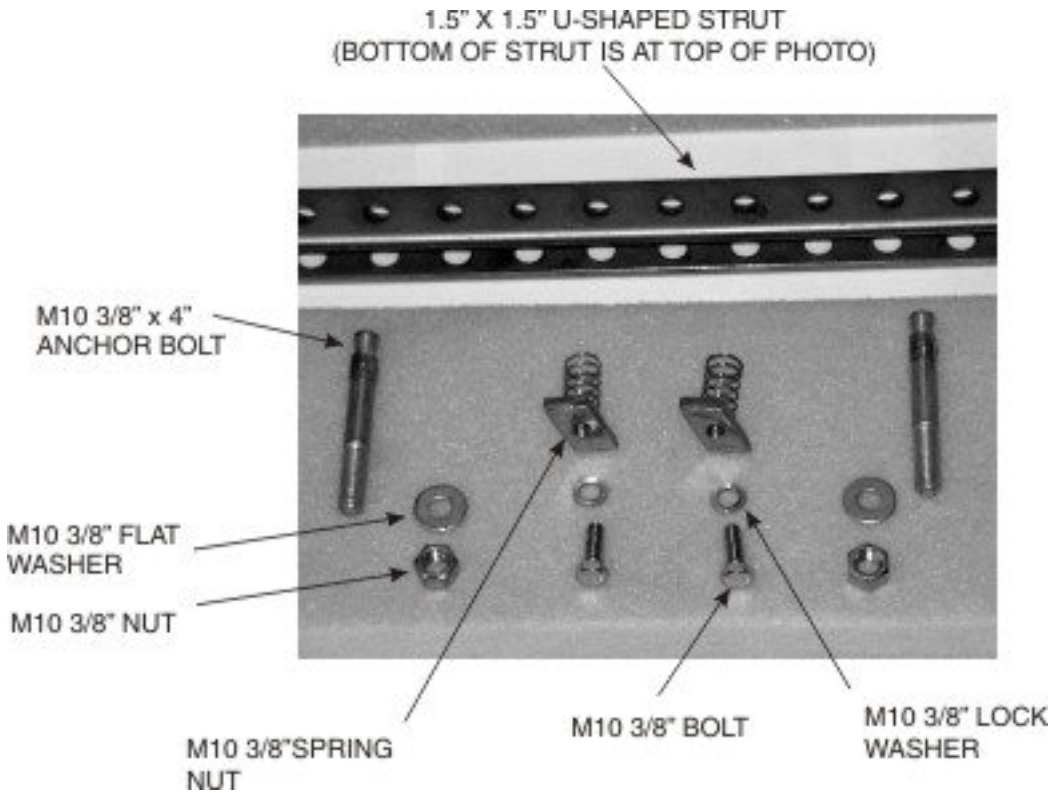

Steps to install unistrut

CAUTION
Equipment damage hazard

Damage to equipment may result.

Prior to drilling holes in a wall, consult with the customer as to the location of gas, water, and electrical pipes or conduits to minimize accidental hazard and equipment damage. Also consult with the building engineer as to local code requirements and wall loading information.

Proceed as follows to install the Unistrut.

- 1 Determine the layout of the struts that will support the RRH.
- 2 Place the top strut on the wall and make sure that the strut is level. Use the holes at the ends of the strut as a template to mark the positions of the holes to be drilled in the wall.

- 3 Place the bottom strut against the wall 350 mm (13.78 inches), measured center to center, from the top strut. Use the holes in the strut as a template to mark the positions of the holes to be drilled in the wall. See the figure below.

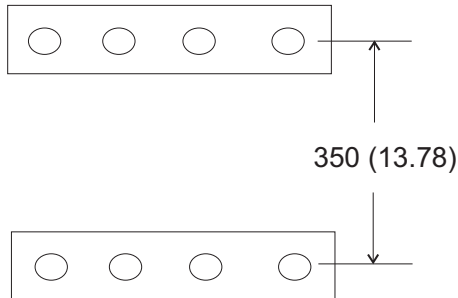

- 4 Drill holes in the wall at the marked positions using an appropriate concrete drill bit for selected anchor.
- 5 To install the top strut, place the top strut against the wall. Drive the anchor bolts into the holes of the strut until nut and washer are flush with the strut.
- 6 Tighten the nut to proper torque requirement.
- 7 Repeat Steps 5 and 6 to install the bottom strut.

END OF STEPS

Site requirements for floor stand installations

Overview

This topic describes site requirements for RRH installation on a floor, such as the location and drilling of anchor holes for the floor stand.

Anchor hole specifications

The following table provides anchoring specifications for seismic zones 0 through 4.

| Equipment | Seismic zone(s) | Anchor type | Number of holes | Hole size mm (inches) | Hole depth mm (inches) | Torque Nm (lbf in) |
|------------|-----------------|------------------|-----------------|-----------------------|------------------------|--------------------|
| Floorstand | 0, 1, 2 | 1/2" Dia drop-in | 4 | 16 mm (5/8 in.) | 50 mm (2 in.) | 24 (212) |
| | 3, 4 | M12 x 125 mm | 4 | 18 mm (11/16 in.) | 100 mm (4 in.) | 79 (700) |

Floor stand

The floor stand shown below is required to install the RRH to the floor.

Unit Mounting Features
(similar to wall mount)

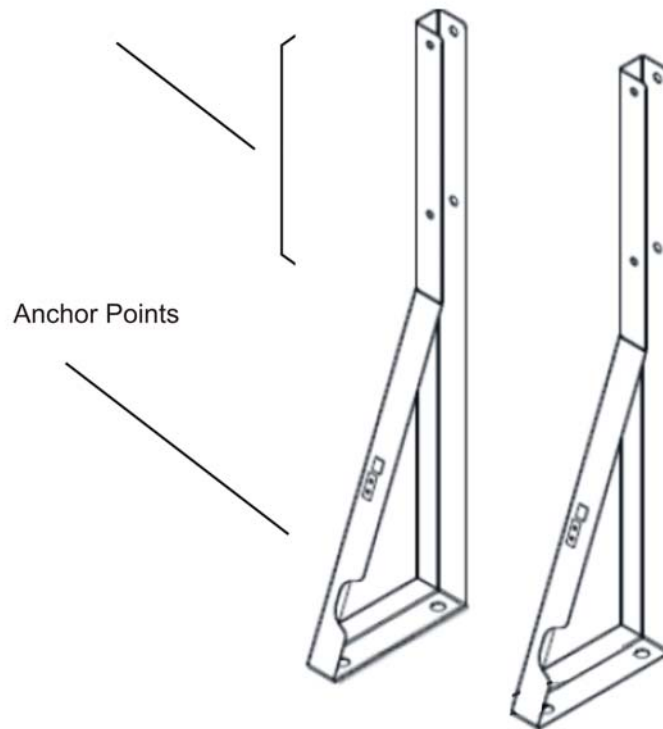

The following figure shows the drill pattern for the floor stand anchor holes.

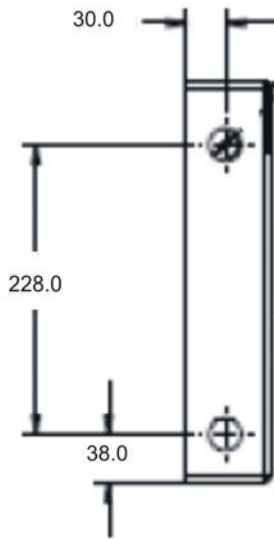

Mark and drill the anchor holes

Important! The marking and drilling of the anchor holes shall be performed as part of site preparation. Anchor holes must be properly covered to prevent debris from falling inside. Before marking or drilling the anchor holes, refer to “RRH clearances” (p. 5-4) for more details.

Proceed as follows to mark and drill the anchor holes in a concrete surface:

- 1 Measure and mark the location where the RRH anchors will be installed. Refer to “RRH clearances” (p. 5-4) and the figure above for anchor footprint.

- 2 Drill the anchor holes to the proper size and depth as specified in the previous table.

Important! If a 100 mm (4.00”) hole depth cannot be attained for a 12-mm expansion stud anchor, a spacer may be removed from the anchor assembly when it is installed. The minimum depth of the hole is 76.2 mm (3.00”).

| 3 | If | Then |
|---|---|---|
| | floor stand <i>is not</i> available on site | tape over the open holes to prevent debris from falling inside. do not install the anchors at this time. Anchors will be installed later by equipment installers. <i>procedure ends here.</i> |
| | floor stand <i>is</i> available on site | continue with next step. |

-
-
- 4 Center floor stand over the drilled anchor holes.

 - 5 Set and torque the anchor bolts.

END OF STEPS

Install strain relief bracket to floor stand

For indoor installations, the strain relief bracket is installed to the floor stand with four screws (M5, 12 mm, Pan Head, Cross), as follows:

-
- 1 Remove the two screws (M5, 10 mm, Pan Head, cross) from each side of the strain relief bracket. Keep them for reinstallation.

 - 2 Slide the strain relief bracket through the top of the floor stand until the M5 threads of the bracket's sides match the according holes in the floor stand.

 - 3 Reinstall the four M5 screws. Do not use washers. Torque to 4 Nm (35 lbf.-in.).

After final installation of RRH and cable connections, the cables should be tied to the strain relief bracket with cable ties.

END OF STEPS
