



EN USER INSTRUCTIONS AND SAFETY

Firmware Version: 1.0x

Congratulations on your purchase of an N-Com product.

N-Com **B1.4** was made using the most advanced technologies and the best materials. Long-running tests and thorough system development have allowed the highest audio quality to be achieved.

For additional information about **B1.4**, and to download high-definition instructions as well as the latest *Firmware* version, visit the website www.n-com.it

REFERENCE STANDARDS

The products of the N-Com line are in compliance with standards as per the table below:

B1.4	The Bluetooth system complies with the main safety requirements and other applicable provisions of Directive 99/5/CE, Directive 2002/95/CE, Directive 2011/65/CE, Directive 2002/96/CE
-------------	--

Battery charger	Directive 2006/95, 2004/108, 2002/95/CE, 2011/65/CE, 2002/96/CE, 2009/125/CE
------------------------	--

Battery	Directive 2006/66/CE
----------------	----------------------

The Declarations of Compliance can be downloaded from the website www.n-com.it (Download section).

FCC ID: Y6MNCOM12	 Bluetooth [®]		
-------------------	---	---	--

Bluetooth is a registered trademark property of Bluetooth SIG, Inc.

Contents

1. WARNINGS AND SAFETY	4
1.1.Road safety	4
1.2.Switching on the system in safe environments	4
1.3.Interferences	4
1.4.Appropriate use	5
1.5.Qualified personnel	5
1.6.Accessories and batteries	5
1.7. Disposal	6
2. CONTENT OF THE PACKAGING	6
3. INSTALLATION – AGGIUNGERE INSTALLAZIONE TASTIERA	7
3.1.Removing the B1.4 system from the helmet	10
4. BASIC FUNCTIONS.....	11
4.1.N-Com Wizard and N-Com App	11
5. PAIRING UP BLUETOOTH DEVICES	12
5.1.Affiliation reset function	12
6. MOBILE PHONE FUNCTIONS.....	13
7. GPS SATELLITE NAVIGATOR FUNCTIONS.....	13
8. BLUETOOTH A2DP MUSIC PLAYER	14
9. AUDIO DEVICES WITH CABLE CONNECTION	14
10. RIDER-PASSENGER INTERCOM MODE.....	14
10.1.Intercom affiliation.....	14
10.2.Intercom function.....	15
11. BATTERY	15
11.1.Battery discharged signal.....	15
11.2.Recharging the system.....	15
12. SUMMARY TABLE OF CONTROLS	16
13. LIMITED WARRANTY	17
13.1.Warranty coverage.....	17
13.2.Exclusions and limitations of the coverage	17
13.3.Validity of this limited warranty	17
13.4.Procedure for the forwarding of claims	18
13.5.Product identification	18
14. WARRANTY REGISTRATION FORM.....	19

1. WARNINGS AND SAFETY

Read this User Manual carefully, as well as the User Manuals for other N-Com kits that you will be using with the N-Com **B1.4**. Read the simple rules listed below. Failure to comply with these rules may lead to dangerous situations.

Caution: The product cannot be used in official or non-official competitions, motordromes, circuits, racing tracks and the like.

Caution: Installation of the N-Com **B1.4** system results in a weight increase of approximately 100g, which is added to the weight of the helmet and of the other accessories.

Warning: The electronic components of the N-Com system mounted inside the helmet are not waterproof. Consequently, make sure the inside of the helmet, including the comfort padding, does not get wet in order to avoid damage to the system. If it does, remove the N-Com system and the helmet comfort padding and let it air dry. Disconnect the battery connector and let it dry as well.

1.1. Road safety

Always obey all Traffic Regulations in force. While riding the motorcycle, your hands should always be engaged in actually riding the vehicle. Any operation to the N-Com system must be carried out with the vehicle stopped. Specifically:

- Set your cell phone on automatic answer (see the cell phone instructions to do this).
- If your cell phone is not equipped with this function, first stop your vehicle in a safe area, in compliance with Traffic Regulations and then answer the call.
- Do not make any calls while riding. Stop your vehicle in a safe place in compliance with Traffic Regulations, and then make the call.
- Adjust the volume so that it does not cause a disturbance or distraction while riding and at the same time allows you to distinctively hear background noises.
- Do not operate your cell phone or other devices connected to N-Com while riding your motorcycle.
- In all cases, obey the Traffic Regulations and remember that riding the motorcycle has absolute priority over any other maneuver.

1.2. Switching on the system in safe environments

- When using the N-Com system, comply with all limitations and instructions related to the use of cell phones.
- Do not turn on your cell phone or the N-Com system whenever their use is forbidden or when the devices can cause interference or dangerous situations.
- Turn off while refueling. Do not use the N-Com system in filling stations. Do not use the device near combustible materials or chemical products.
- Turn off in proximity to explosive materials.

1.3. Interferences

All phones and devices with wireless signal transmission are subject to interferences that may affect the performance of the device connected to them. These interferences are not ascribable to a defect of the N-Com system.

1.4. Appropriate use

Use the device only in the normal position, as described in the product documentation. Do not attempt to disassemble, tamper with or modify any part of the N-Com system.

Caution: Adjust the volume of the N-Com system (where provided) and of the audio sources connected to it before you use the system on the road.

Caution: Adjusting the volume to very high levels may cause damage to your hearing.

Caution: Adjust the volume of the N-Com system (where provided) and of the audio sources connected to it so as to avoid audio reproduction at high volumes. Constant exposure to high audio volumes may damage your hearing.

Caution: An incorrect installation of the system in the helmet may alter the aerodynamic and safety characteristics of the helmet itself, thus creating dangerous conditions. Install the N-Com system according to the instructions provided in the product documentation. In case of doubt, please contact your local N-Com dealer.

Warning: Listening to other equipment should not interfere with driving the vehicle, which must be the top priority at all times. Carry out all operations on the electronic equipment and on the N-Com system with the vehicle stopped, in compliance with Traffic Regulations.

1.5. Qualified personnel

- Only qualified personnel can carry out technical assistance on this product. In case of any malfunction, always turn to your local dealer.
- The helmet is a safety device. Tampering with it and/or with the electronic system inside the helmet, in addition to invalidating the product warranty, can also lead to dangerous situations.

1.6. Accessories and batteries

- Only use the type of batteries, battery chargers and accessories approved by Nolan for the specific model.
- The use of a battery type different from the recommended one may lead to dangerous situations and invalidate the warranty.
- Contact your local dealer to see about the availability of approved accessories.
- When disconnecting the power supply cable of any accessory or of the battery charger, always grab and pull the plug not the cable.
- Do not use batteries for purposes other than the prescribed ones.
- Never use batteries or battery chargers that turn out to be damaged.
- Do not short-circuit the battery.
- Keep the battery at a temperature between **0° / +45°C (charging); -20° / +60 °C (in use)**.
- Danger of fire or explosion: do not throw the batteries into a fire nor expose them to high temperatures!
- Do not throw out batteries together with household refuse. The batteries should be disposed of in compliance with local regulations
- Do not wear the helmet while the battery is recharging.
- The helmet should never be left within the reach of unsupervised children in order to prevent damage to their health caused by access to the batteries.

Battery	Lithium Ion AB463651BU	3,7V – 800mAh
Battery charger	AK00G-0500040VU	100/240v – 50/60 Hz 5V – 0,4 A
	S-TR-038	100-240V - 60/50Hz 0.1A

1.7. Disposal

Refer to this user manual and to manuals related to other parts of the N-Com system in order to disassemble the system from the helmet. Once the system has been disassembled, dispose of it according to the following instructions:



- The presence of a crossed-out wheelie bin indicates that in the European Union the product is subject to separate collection at the end of its useful life (European Directive 2002/96/EC).



- Do not dispose of these products together with undifferentiated urban waste.
- The proper disposal of obsolete equipment contributes to preventing possible negative consequences on people's health and on the environment.
- For more detailed information on the disposal of obsolete equipment, contact your municipality, a waste disposal service or the store where the product was purchased.

2. CONTENT OF THE PACKAGING

The N-Com **B1.4** package contains:

N-Com B1.4 system	
Keypad	Mini USB wire
Battery charger	Key

3. INSTALLATION

You can download the installation video from www.n-com.it N-Com / Download section.

- Before you install the **B1.4** system on the helmet, make sure it turns on properly. Press the “on” key for about 2 seconds, until the LED lights up and you hear a beep in the headset. Proceed with the installation.
- Remove the cheek padding (see helmet instructions).

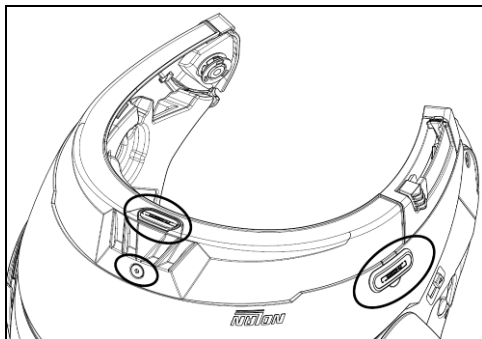

Fig. 1

- Remove the helmet edge gasket using the special tool (Fig. 1).
- Remove the “N-Com” plugs found at the back of the shell gasket and on the left side of the helmet (Fig. 2).

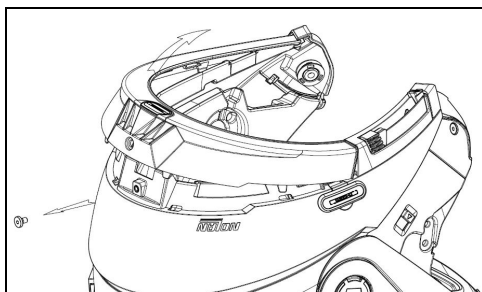

Fig. 2

- Completely remove the gasket as shown in Fig. 2; by doing so you also remove the padding.

- Prior to installing the N-Com system, remove any filling foam material found in the helmet.

Option 1: remove the bottom element in foam material and the filling materials in the housings of the N-Com earpieces located in the EPS cheek pads.

Option 2: remove the left and right side filling material as well as the filling material in the housings of the N-Com earpieces located in the EPS cheek pads.

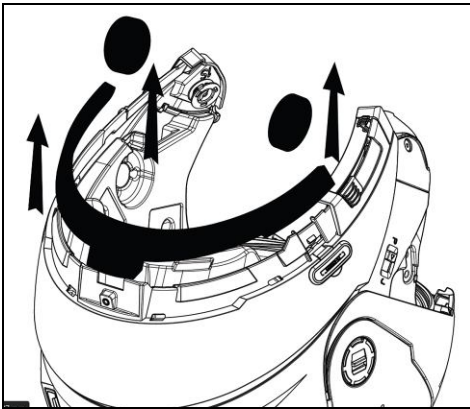

Option 1

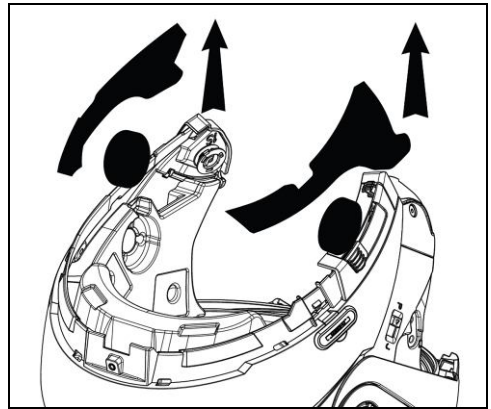

Option 2

N.B.: Keep the filling material in case you wish to use the helmet without the N-Com system in the future.

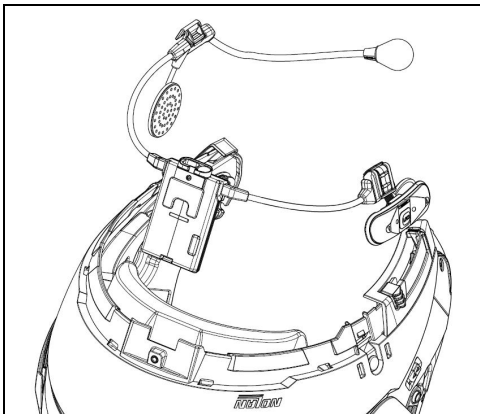

Fig. 3

- Place the system in the special housing in the back of the helmet, pushing it all the way into the groove (Fig. 3).

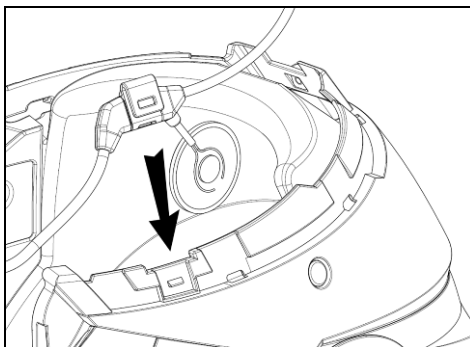

Fig. 4

- Fix the cable inside the helmet and make sure the right fixing clip snaps into its housing (Fig. 4)

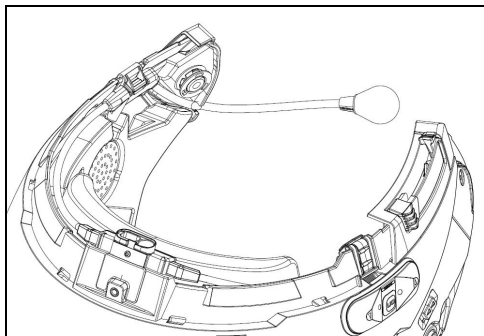

Fig. 5

- Position the microphone in the housing on the left of the helmet, inserting the metal boom in the groove found in the chin guard coupling frame (Fig. 5).

Caution: make sure that the side of the microphone support with the writing "N-Com" is facing inward.

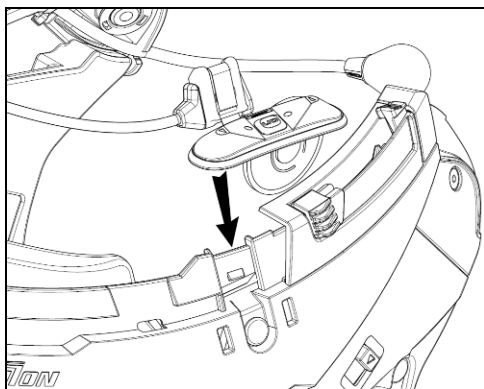

Fig. 6

- Fix the cable inside the helmet and make sure the left fixing clip snaps into its housing.
- Hook up the keypad to the helmet by clicking in the relevant hooks.

- Position the left and right speakers in the respective housing obtained in the polystyrene cheek padding. If necessary, rotate the speakers slightly in their housing.
- Reassemble the gasket and secure it with the specific screw
- Reassemble the cheek padding.

3.1. Removing the B1.4 system from the helmet

Proceed as follows to remove the **B1.4** system from the helmet:

- Remove the cheek padding and the shell gasket;

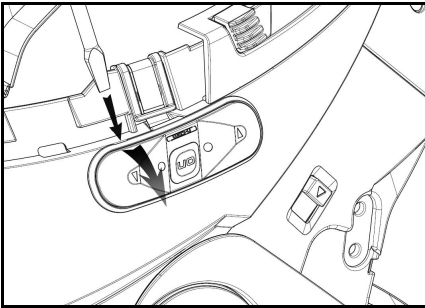

Fig. 7

- Remove the keypad from the shell, using a flat head screwdriver (or a similar tool) to lever upwards in the special hollow as shown in fig. 7.

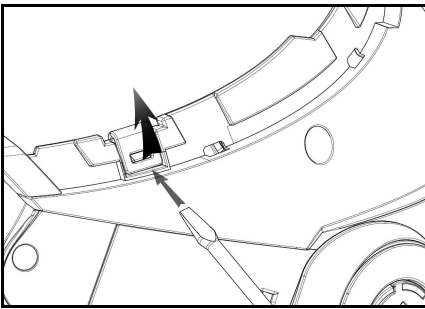

Fig. 8

- Unhook the right and left clips from the shell, levering upward using a flat head screw (or a similar tool), as shown in figure 8.

- Completely remove the **B1.4** system from the helmet and re-install the cheek padding and the gasket.

4. BASIC FUNCTIONS

System ON	Press " on " and keep it pressed for about 2 seconds, until the LEDs turn on and you hear a beep in the headset.
System OFF	Press " on " and keep it pressed for about 4 seconds, until the LEDs turn off and you hear a beep in the headset.
Increase Volume	Briefly press " ▲ " to increase the volume. A double tone signals the highest volume level.
Decrease Volume	Briefly press " ▼ " to decrease the volume. A double tone signals the lowest volume level.

4.1. N-Com Wizard and N-Com App



"N-Com Wizard" is the PC application that can be used to manage and configure the M5 system.

The program can be downloaded from the Internet site www.n-com.it, in the "Download" section. In order to use it, a helmet equipped with M5 must be connected to the PC, using the USB cable supplied with the system.

The functions that can also be managed from the N-Com Wizard are listed here below with the specific icon.



The N-Com system is preset to be hooked up to the "N-Com App", the application compatible with Android that can be used to configure and operate the N-Com system directly from a Smartphone.

With the N-Com App, you can carry out most of the functions included in the N-Com Wizard program or, alternatively, it can be used as a wireless Bluetooth keypad.

The N-Com APP can be downloaded free of charge from Google Play.

For additional details, please visit the website www.n-com.it

The functions that can also be managed from the N-Com Wizard are listed here below with the specific icon.

5. PAIRING UP BLUETOOTH DEVICES

In order for the **B1.4** system to be connected to another Bluetooth device, the latter needs to be first paired up with the N-Com system.

The pairing up procedure is the same for all Bluetooth devices: mobile phones, MP3 Bluetooth players, satellite navigators, etc.

1. Make sure the **B1.4** is turned off;
2. Press "**on**" and keep it pressed (for more than 6 seconds), until the LEDs start to flash quickly and you hear a sharp beep in the headset, indicating the "Pair-up mode";
3. On the Bluetooth device, turn on the search for Bluetooth devices (refer to the instructions manual of your device for the proper pairing up procedure, as it varies depending on the brand and model of the device);
4. After a few seconds, the device will display the name "N-Com B1.4 v.X.XX", followed by the manufacturer's identification data;
5. Select the N-Com device. If a password is requested, enter **0000** (four zeros);
6. **B1.4** will confirm the pairing up by means of a tone in the headset, and the LEDs will stop flashing;
7. Turn off and on both the device and the **B1.4** to store the pairing up data.

Note: The affiliation is stored in the helmet and in the cell phone and it is not lost when the two devices are turned off. As a result it needs to be carried out only once.

Note: If a Bluetooth device (mobile phone or GPS) equipped with music player with Bluetooth A2DP player has already been paired up, the pairing up DOES NOT have to be repeated as the A2DP protocol has already been stored in the **B1.4**.

Once the Bluetooth device has been paired up, connection is automatic when the system is turned on.

5.1. Affiliation reset function

You can remove all affiliated devices from the system memory. This operation is not reversible; right after resetting, you will have to repeat the affiliation procedure for the cell phone (or for other compatible Bluetooth devices).

To erase all devices previously affiliated, proceed as follows:

- Press "**on**" and keep it pressed (for more than 4 seconds), until the LEDs start to flash quickly and you hear a sharp beep in the headset, indicating the "Pair-up mode";
- Press "**▲**" and "**▼**" at the same time for 4 seconds, and release them when you hear a beep. The N-Com will emit a special acoustic signal to confirm and will then turn itself off.



This function can also be turned on through PC using the "N-Com Wizard" programme.

6. MOBILE PHONE FUNCTIONS

Answering a phone call	Briefly press any key when you hear the incoming call signal
Hanging up/rejecting a phone call	Press "on" and keep it pressed for about 2 seconds (until you hear the acoustic signal)
Voice call (if equipped)	Press "on" and keep it pressed for about 2 seconds (until you hear the acoustic signal)
Redial last number	Briefly press "▲" and "▼" at the same time
Transferring a call from helmet to mobile phone	To transfer an ongoing call from the helmet to the mobile phone, press both "▲" and "▼" at the same time and keep them pressed for 4 seconds

Conference call function

B1.4 allows a conference call with Rider and Pillion Passenger.

When a call comes in on a mobile phone connected via Bluetooth to **B1.4**, the Rider-Pillion Passenger intercom is temporarily turned off. However, if you wish to share the phone call with the other helmet, simply turn on the intercom manually during the phone call (by briefly pressing "on").

Caution: this function is available only if the Pillion Passenger helmet is also equipped with a N-Com system provided with the same function.

7. GPS SATELLITE NAVIGATOR FUNCTIONS

B1.4 is compatible with the most common satellite navigators for motorcycles.

By connecting the N-Com system to the GPS, all instructions will be transferred to the helmet.

Every time the navigator communicates instructions, the intercom via Bluetooth with the Pillion Passenger is cut off and automatically restored at the end of the communication.

Note: If the navigator is pre-set for connection to a Bluetooth mobile phone, you will be able to receive the phone call audio directly in the helmet through the GPS. In this case, you can answer the call directly from the navigator.

GPS Conference Call Function

The Conference function allows you to keep the "Rider-Pillion Passenger" intercom open even while the satellite navigator is giving instructions, thus preventing the intercom mode to be turned off every time the navigator gives instructions. However, if you wish to activate the Conference GPS function, simply turn on the intercom manually during the GPS directions (by briefly pressing "on").

Caution: this function is available only if the Pillion Passenger helmet is also equipped with a N-Com system provided with the same function.

At the end of the GPS communication, the intercom with the second helmet stays open and the "Conference" setting is stored for future GPS communications.

8. BLUETOOTH A2DP MUSIC PLAYER

You can listen to high quality music by connecting **B1.4** to a device equipped with Bluetooth A2DP (Advanced Audio Distribution Profile) protocol.

The **B1.4** system is also equipped with Bluetooth AVRCP (Audio Video Remote Control Profile) protocol, which allows you to stop and resume music reproduction directly from the helmet (with devices equipped with AVRCP).

Connection to A2DP music player	The connection is automatic when you turn on the system. <u>Wait a few seconds for the connection.</u>
Play music (Play)	Press the "▲" button and keep it pressed for 2 seconds.
Pause function (Pause)	When the player is connected and playing music, press "▲" for 2 seconds.
Next track (Skip)	When the player is playing music, press "▲" for 4 about seconds.
Stop playing music (Stop)	Press "▼" for 2 seconds.

Note: The Bluetooth intercom does not work while listening to an A2DP audio source or an un Mp3 player connected via cable.

9. AUDIO DEVICES WITH CABLE CONNECTION

N-Com B1.4 allows connection via cable (sold separately) to audio sources equipped with the 3.5mm output generally used by these devices for the headsets.

To listen to the audio source, connect the cable to the helmet using the mini-USB port, then start playing the audio file on the device, then activate the audio peripheral device using the specific key.

You can turn on or off listening in the helmet by pressing the "▼" and "on" key at the same time.

N.B. : You cannot stay connected in intercom mode with the pillion passenger while using the audio source via cable.

10. RIDER-PASSENGER INTERCOM MODE

In order to use **B1.4** in wireless intercom mode, both helmets have to be equipped with a N-Com Bluetooth system.

In order for two N-Com systems to communicate with one another, they have to be paired up first.

10.1. Intercom affiliation

1. Make sure both N-Com Bluetooth systems are turned off;
2. Set both N-Com Bluetooth systems in Pairing up mode by pressing "on" (for more than 4 seconds), until the LEDS start to flash quickly;
3. On either one of the two helmets, press "on" briefly;
4. After a few seconds, the helmets "recognize" each another, a beep is emitted to signal the pair up was successful and intercom communication is activated;
5. Turn off both N-Com Bluetooth systems and turn them back on to store the pair up data.

10.2. Intercom function

To activate the intercom connection, turn on the two N-Com systems and **briefly** press “on” on one of the helmets.

Intercom activation	With B1.4 turned on, briefly press “on”.
Intercom deactivation	With B1.4 turned on, briefly press “on”.

11. BATTERY

Before using the N-Com device for the first time, recharge the battery completely for at least 10 hours. To obtain best performances from the battery, it is recommended to completely recharge the battery the first few times. Afterwards, you can recharge the battery for shorter periods. Whenever possible, it is best to recharge the battery completely.

11.1. Battery discharged signal

When turned on, the system signals when the battery is running down by switching to the “Reserve” mode.

When the battery charging power falls below 1 hour of operation, the buttons “▲” and “▼” start to flash in order to indicate that the system is in “Reserve” mode. Three consecutive beeps also signal the reserve mode.

When the battery operates in “Reserve”, the system automatically turns itself off in case no button is pressed for 30 minutes. The shutting off is signaled by a series of beeps in the helmet. This function makes it possible to always have a small reserve of energy to use it again in case you forget to turn off your helmet.

11.2. Recharging the system

To recharge the **B1.4** system, connect the USB cable to a battery charger or to a powered USB port. Charging occurs as follows:

B1.4 system turned off	When you connect the B1.4 system to the battery charger, the blue LED begins to flash. When the battery is fully charged, the blue LED stops flashing and stays on.
B1.4 system turned on	When you connect the B1.4 system to the battery charger, the red LED begins to flash. When the battery is fully charged, the red LED turns off.

N.B.: If the device has not been charged for a long time (a few months), it may not be possible to turn on the system during the first few minutes of the charging, as the voltage may drop below the minimum limit.

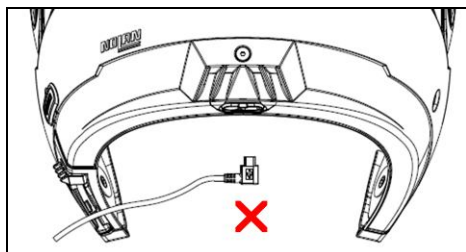
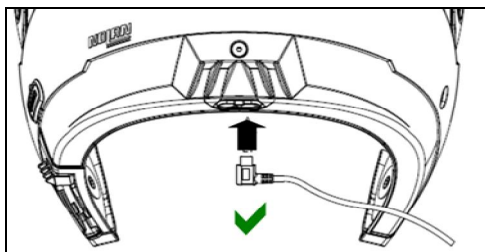

12. SUMMARY TABLE OF CONTROLS

Button		on	on	▲	▲	▼	▼	▲ ▼	▲ ▼
		Brief	Long	Brief	Long	Brief	Long	Brief	Long
Basic Functions	Turning on		X (3s)						
	Turning off		X (4s)						
	Increase Volume			X					
	Decrease Volume					X			
	Activate / Deactivate audio via cable						X (2s)		
	Activate intercom	X							
	Deactivate intercom	X							

Bluetooth peripheral	Answer phone call	X		X		X			
	Voice call		X (2s)						
	Hang up/reject a phone call		X (2s)						
	Redial last number							X	
	Mobile phone connection		X (2s)						
	Mobile phone disconnection								X (4s)
	Call transfer								X (4s)
	Activate Conference Mode	X							

Mp3 player	Disconnect A2PD device						X (2s)		
	Play music (Play)				X (2s)				
	Pause Function (Pause)				X (2s)				
	Next track (Forward)				X (4s)				

Setting	Pairing up mode - system turned off		X (4s)						
	Rider-Passenger intercom pair up	X							
	Erase pair ups**								X (4s)

*Briefly press at the same time.

**With N-Com system in Pairing up Mode.

13. LIMITED WARRANTY

With this LIMITED WARRANTY CERTIFICATE, Nolangroup warrants this Product to be free from defects in material and workmanship at the time of its original purchase by the buyer. We invite you to:

- Read the cautions pertaining to safety and proper use.
- Read the warranty terms and conditions.
- Keep the original sales receipt. This must be shown in case of repairs covered by warranty. In these cases, the product has to be taken back to the dealer where it was purchased.

13.1. Warranty coverage

If any defect covered by this limited warranty certificate is discovered within 2 (two) years from the purchase date shown on the tax receipt, Nolangroup shall repair or replace the defective product through its distribution network after having verified the defect. Nolangroup shall supply all the material and labor that is reasonably required to remedy the defect, except in those cases where the damage is caused by one of the items listed in the following paragraph "Exclusions and limitations of the Coverage".

13.2. Exclusions and limitations of the coverage

This warranty only covers defects in materials and manufacturing. Nolangroup shall not be considered responsible for product defects that can be attributed, either partially or in full, to any other cause, including but not limited to:

- Defects or damages resulting from using the Product in conditions that differ from the usual ones.
- Damages caused by improper use not conforming with normal operation in accordance with the product operating and maintenance instructions provided by Nolangroup.
- Negligence and normal wear of internal and external parts.
- Any damage caused by an accident;
- Any change or modification made to the helmet or to the N-com system by the user or by third parties.
- Color changes or damages caused by exposure to harmful chemical products.
- The use of incompatible accessories that are not part of the N-Com product range.
- Moreover, the warranty does not cover product defects caused by fortuitous events, modifications or adjustments, causes of force majeure or damages deriving from the product coming in contact with liquids.
- The internal helmet components are not and cannot be waterproof. Consequently, any improper exposure to rain, humidity, food spillages or other liquids can result in damages to the N-Com electronic devices, damages for which Nolangroup shall not be responsible.
- This warranty does not include those parts subject to wear and tear such as, for example, the rechargeable battery and the cables used for connection between the various N-Com systems or between the N-Com systems and other devices.
- Since Nolangroup does not supply the system on which the cell phones work, it shall not be responsible for the operation, availability, coverage, services or range pertaining to the aforementioned system.
- Whenever the product is used in conjunction with accessories or equipment not supplied by Nolangroup, Nolangroup shall not guarantee proper operation of the product/device combination, nor will it accept requests for repairs or replacements under warranty in case the product is used in such a way.

Nolangroup shall not be responsible in case the product presents limited capabilities due to the operating mode of cell phones or of other accessories or equipment not supplied by Nolangroup.

Tampering with the internal electronic card or with other parts of the N-Com system shall invalidate the warranty.

Moreover, the defects covered by this warranty do not include all those specific and subjective situations that may come up during the active use of the helmet such as, for example, comfort problems while riding or aerodynamic noises.

Nolangroup shall not be held responsible in any case for incidental or consequential damages (including, without any limitation whatsoever, damages to one or more persons) resulting from non-fulfillment of the obligations arising from this warranty as it pertains to Nolangroup products.

13.3. Validity of this limited warranty

This warranty is valid only if the enclosed warranty form is duly and completely filled out with the following information:

- Product identification code
- Name and stamp of the authorized dealer.
- Product purchase date.
- Buyer's name and address.

Nolangroup reserves itself the right to not carry out repairs under warranty if the aforementioned information is removed or modified after the original purchase of the product from the dealer.

13.4. Procedure for the forwarding of claims

To forward a claim covered by this warranty, the buyer has to directly notify the dealer where the helmet was purchased with regards to the defect, presenting at the same time the defective product, a copy of the sales receipt and the Warranty registration form, duly filled out as instructed above.

PRIOR TO CONTACTING THE DEALER, WE RECOMMEND THAT YOU READ CAREFULLY THE USER MANUAL ENCLOSED WITH THE PRODUCT.

AFTER 2 (TWO) YEARS FROM THE DATE OF PURCHASE, THIS LIMITED WARRANTY IS VOID FOR ALL EFFECTS AND PURPOSES.

Repairs or maintenance under warranty do not extend the period of the warranty itself. Therefore, in case the product or one of its components is replaced, this does not initiate a new warranty period, as the purchase date of the original product shall be taken into account for warranty purposes.

Only for repairs or replacement of electronic components, in the event that Nolangroup proceeds to repairing or replacing the product, said product shall enjoy a warranty period equal to the residual portion of the original warranty or ninety (90) days from the repair date (the longer period being considered).

The repair or replacement can be carried out even with regenerated components with equivalent functions.

The replaced parts or components shall become property of Nolangroup.

THIS WARRANTY VOIDS AND REPLACES ANY OTHER WRITTEN OR VERBAL WARRANTIES PROVIDED FOR BY THE LAW THAT CAN BE DEROGATED AT THE PARTIES' WILL; SPECIFICALLY, NOLANGROUP DOES NOT GRANT SPECIFIC WARRANTIES OF MERCHANTABILITY OR FITNESS FOR A PARTICULAR PURPOSE. IN NO CASE SHALL NOLAN BE LIABLE FOR INCIDENTAL OR CONSEQUENTIAL DAMAGES INCLUDING BUT NOT LIMITED TO LOST PROFITS OR COMMERCIAL DAMAGES, TO THE FULL EXTENT THOSE DAMAGES CAN BE DISCLAIMED BY THE LAW.

NOLANGROUP RESERVES ITSELF THE RIGHT TO MODIFY, AT ANY TIME AND WITHOUT ADVANCE NOTICE, THE PRODUCT CHARACTERISTICS, FUNCTIONS, COMPATIBILITY AND SOFTWARE.

Some Countries do not allow the exclusion or limitation of incidental or consequential damages, or the limitation of the duration of implied warranties; as a result of this, the previous limitations and exclusions may not be applicable to you.

This warranty does not have any effect on the customer's legal rights under the national jurisdiction in force or on the consumer's rights towards the dealer sanctioned by the purchase/sale contract.

This warranty is valid throughout the European territory, and it represents the only express warranty provided by Nolangroup in relation to the sale of its own products. This warranty does not affect the rights to which the buyer is entitled and which are expressly provided for by Directive 1999/44/CE.

This warranty does not affect the consumer's rights provided for by the law, and specifically by the provisions of Legislative Decree 2 February 2002 n. 24.

13.5. Product identification

N-Com products are identified by means of a code that allows product traceability and identification.

The identification code is printed on the adhesive label applied to the **B1.4** system, under the rechargeable battery.

14. WARRANTY REGISTRATION FORM

Product name: **B1.4**

Identification code

--	--	--	--	--	--	--	--	--	--	--	--	--	--	--

Buyer's Information

Name

Last name

Address

Phone

e-mail

Dealer's stamp

Date of purchase

FCC Statement

This equipment has been tested and found to comply with the limits for a Class B digital device, pursuant to Part 15 of the FCC Rules. These limits are designed to provide reasonable protection against harmful interference in a residential installation. This equipment generates uses and can radiate radio frequency energy and, if not installed and used in accordance with the instructions, may cause harmful interference to radio communications. However, there is no guarantee that interference will not occur in a particular installation. If this equipment does cause harmful interference to radio or television reception, which can be determined by turning the equipment off and on, the user is encouraged to try to correct the interference by one or more of the following measures:

- Reorient or relocate the receiving antenna.
- Increase the separation between the equipment and receiver.
- Connect the equipment into an outlet on a circuit different from that to which the receiver is connected.
- Consult the dealer or an experienced radio/TV technician for help.

This device complies with part 15 of the FCC Rules. Operation is subject to the following two conditions:

(1) This device may not cause harmful interference, and (2) this device must accept any interference received, including interference that may cause undesired operation.

Changes or modifications not expressly approved by the party responsible for compliance could void the user's authority to operate the equipment.



www.n-com.it

