

USER INSTRUCTIONS AND SAFETY

Congratulations on your purchase of an N-Com product.

N-Com B901L was made using the most advanced technologies and the best materials. Long-running tests and thorough system development have allowed the highest audio quality to be achieved.

For additional information about B901L, and to download high-definition instructions as well as the latest Firmware version, visit the website www.n-com.it

Firmware version: 1.0

REFERENCE STANDARDS



The products of the N-Com line are in compliance with standards as per the table below:

B901L	The Bluetooth system complies with the main safety requirements and other applicable provisions of Directive 99/5/CE, Directive 2009/65/EC, Directive 2011/65/CE, Directive 2012/19/EU
--------------	--

Battery charger	Directive 2006/95, 2004/108, 2009/65/EC, 2011/65/EC, 2012/19/EU, 2009/125/CE
------------------------	--

Battery	Directive 2006/66/CE
----------------	----------------------

The Declarations of Compliance can be downloaded from the website www.n-com.it (Download section).

FCC ID: Y6MNCOM15	IC: 9455A-NCOM15	 Bluetooth®	 R-NZ	
-------------------	------------------	---	--	--

The Bluetooth® word mark and logos are registered trademarks owned by the Bluetooth SIG, Inc. and any use of such marks by N-Com is under license. Other trademarks and trade names are those of their respective owners.

Model: B901L R

Contents

1. WARNINGS AND SAFETY	4
1.1.Road safety	4
1.2.Switching on the system in safe environments	4
1.3.Interferences	4
1.4.Appropriate use	4
1.5.Qualified personnel	5
1.6.Accessories and batteries	5
1.7. Disposal	5
2. CONTENT OF THE PACKAGING	6
3. INSTALLATION ON THE HELMET	7
3.1.Preparing the ESS system	8
3.2.Installing the ESS system on the helmet	9
3.3.Positioning the ESS system on the helmet	12
3.4.Removing the B901L system from the helmet	12
4. BASIC FUNCTIONS	14
4.1.Volume adjustment	14
4.2.Auto On / Off function	14
4.3.N-Com EASYSET	14
5. CONFIGURATION MENU	15
6. PAIRING UP WITH MOBILE PHONES OR OTHER BLUETOOTH DEVICES	16
7. MOBILE PHONE	16
7.1.Speed dialling	16
7.2.Conference call function	17
8. MANAGING TWO MOBILE PHONES (OR BLUETOOTH DEVICES)	18
9. MUSIC VIA BLUETOOTH	18
9.1.Sharing music via Bluetooth (<i>A2DP Sharing</i>)	18
10. MUSIC VIA CABLE	19
11. SATELLITE NAVIGATOR FOR MOTORCYCLES	19
13. LED SIGNALLING LIGHTS	20
13.1.Emergency Stop Signal ESS (mode 1)	20
13.2.Rear Light (mode 2)	20
13.3.Poor visibility light (mode 3)	21
14. N-COM INTERCOM (SERIES "900")	21
14.1.Intercom pairing up	21
14.2.Intercom function (one-to-one connection)	21
14.3. <i>Smart Conference</i> (Group Intercom)	22
15. "UNIVERSAL INTERCOM" INTERCOM	23
15.1.Pairing up the UNIVERSAL INTERCOM	23
15.2.Universal Intercom Function	24
15.3.Universal Conference (chain intercom)	24
16. REMOTe control	26
17. BATTERY AND RECHARGE	26
17.1.Low battery signal	26
17.2.Charging the system	26
18. SUMMARY TABLE OF CONTROLS	27
19. LIMITED WARRANTY	29
19.1.Warranty coverage	29
19.2.Exclusions and limitations of the coverage	29
19.3.Validity of this limited warranty	30
19.4.Procedure for the forwarding of claims	30
19.5.Product identification	30
20. WARRANTY REGISTRATION FORM	31

1. WARNINGS AND SAFETY

Read this User Manual carefully, as well as the simple rules listed below. Failure to comply with these rules may lead to dangerous situations.

Caution: The product cannot be used in official or non-official competitions, motordromes, circuits, racing tracks and the like.

Caution: Installation of the N-Com B901L system results in a weight increase of approximately 120g, which is added to the weight of the helmet and of the other accessories.

Warning: The electronic components of the N-Com system mounted inside the helmet are not waterproof. Consequently, make sure the inside of the helmet, including the comfort padding, does not get wet in order to avoid damage to the system. If it does, remove the N-Com system and the helmet comfort padding and let it air dry. Remove the battery from its housing and let it dry.

1.1. Road safety

Always obey all Traffic Regulations in force. While riding the motorcycle, your hands should always be engaged in actually riding the vehicle. Any operation to the N-Com system must be carried out with the vehicle stopped. Specifically:

- Set your cell phone on automatic answer (see the cell phone instructions to do this).
- If your cell phone is not equipped with this function, first stop your vehicle in a safe area, in compliance with Traffic Regulations and then answer the call.
- Do not make any calls while riding. Stop your vehicle in a safe place in compliance with Traffic Regulations, and then make the call.
- Adjust the volume so that it does not cause a disturbance or distraction while riding and at the same time allows you to distinctively hear background noises.
- Do not operate your cell phone or other devices connected to N-Com while riding your motorcycle.
- In all cases, obey the Traffic Regulations and remember that riding the motorcycle has absolute priority over any other manoeuvre.
- The B901L system is equipped with an emergency brake light (ESS – Emergency Stop Signal). The ESS system IS NOT intended to replace the stop or brake lights fitted on the motorcycle, consequently its operation alone is not enough for proper brake signaling.
- Make sure that the use of the emergency brake light (ESS – Emergency Stop Signal) is not in conflict with the regulations in force in the country where you will be travelling.

1.2. Switching on the system in safe environments

- When using the N-Com system, comply with all limitations and instructions related to the use of cell phones.
- Do not turn on your cell phone or the N-Com system whenever their use is forbidden or when the devices can cause interference or dangerous situations.
- Turn off while refuelling. Do not use the N-Com system in filling stations. Do not use the device near combustible materials or chemical products.
- Turn off in proximity to explosive materials.

1.3. Interferences

All phones and devices with wireless signal transmission are subject to interferences that may affect the performance of the device connected to them. These interferences are not ascribable to a defect of the N-Com system.

1.4. Appropriate use

Use the device only in the normal position, as described in the product documentation. Do not attempt to disassemble, tamper with or modify any part of the N-Com system.

Caution: Adjust the volume of the N-Com system (where provided) and of the audio sources connected to it before you use the system on the road.

Caution: Adjusting the volume to very high levels may cause damage to your hearing.

Caution: Adjust the volume of the N-Com system (where provided) and of the audio sources connected to it so as to avoid audio reproduction at high volumes. Constant exposure to high audio volumes may damage your hearing.

Caution: An incorrect installation of the system in the helmet may alter the aerodynamic and safety characteristics of the helmet itself, thus creating dangerous conditions. Install the N-Com system according to the instructions provided in the product documentation. In case of doubt, please contact your local N-Com dealer.

Warning: Listening to other equipment should not interfere with driving the vehicle, which must be the top priority at all times. Carry out all operations on the electronic equipment and on the N-Com system with the vehicle stopped, in compliance with Traffic Regulations.

1.5. Qualified personnel

- Only qualified personnel can carry out technical assistance on this product. In case of any malfunction, always turn to your local dealer.
- The helmet is a safety device. Tampering with it and/or with the electronic system inside the helmet, in addition to invalidating the product warranty, can also lead to dangerous situations.

1.6. Accessories and batteries

Only use the type of batteries, battery chargers and accessories approved by Nolan for the specific model.

The use of a battery type different from the recommended one may lead to dangerous situations and invalidate the warranty.

Contact your local dealer to see about the availability of approved accessories.

When disconnecting the power supply cable of any accessory or of the battery charger, always grab and pull the plug not the cable.

Do not use batteries for purposes other than the prescribed ones.

Never use batteries or battery chargers that turn out to be damaged.

Do not short-circuit the battery.

Keep the battery at a temperature between **0° / +32°C (charging): -20° / +55°C (in use)**.

Danger of fire or explosion: do not throw the batteries into a fire nor expose them to high temperatures!

Do not throw out batteries together with household refuse. The batteries should be disposed of in compliance with local regulations

Do not wear the helmet while the battery is recharging.

The helmet should never be left within the reach of unsupervised children in order to prevent damage to their health caused by access to the batteries.

Battery	PL523450P	Lithium 3,7V – 1000 mAh
Battery charger	S-TR-009L	100/240V – 50/60 Hz 5V - 0.5 A

1.7. Disposal

Refer to this user manual and to manuals related to other parts of the N-Com system in order to disassemble the system from the helmet. Once the system has been disassembled, dispose of it according to the following instructions:





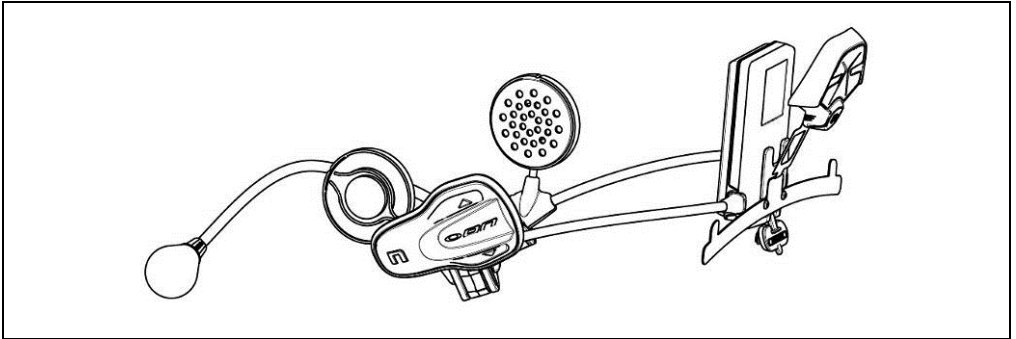

- The presence of a crossed-out wheeled bin indicates that in the European Union the product is subject to separate collection at the end of its useful life.
- Do not dispose of these products together with undifferentiated urban waste.
- The proper disposal of obsolete equipment contributes to preventing possible negative consequences on people's health and on the environment.
- For more detailed information on the disposal of obsolete equipment, contact your municipality, a waste disposal service or the store where the product was purchased.

2. CONTENT OF THE PACKAGING

The N-Com B901L package contains:

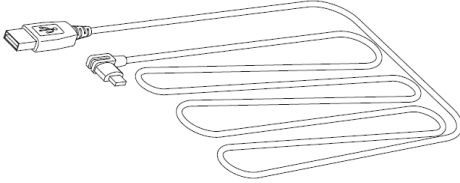
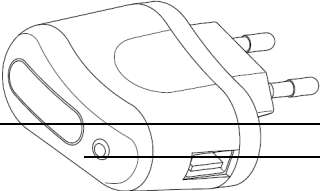
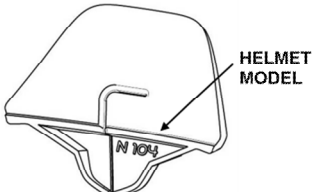

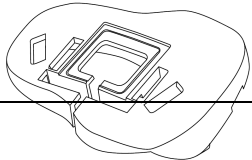
N-Com B901L system

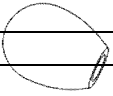
		
 <p>HELMET MODEL</p>		
		

3. INSTALLATION ON THE HELMET

Important: Prior to installing the N-Com system, it is recommended to write down the identification code affixed to the product (see chapter 19.5).

You can download the installation video from www.n-com.it N-Com / Download section.

- Before you install the B901L system on the helmet, make sure it turns on properly. Press the “ON” key for about 2 seconds, until the blue LED on the key pad lights up and you hear a beep in the headset. Proceed with the installation.
- Remove the cheek padding (see helmet instructions).
- Remove the helmet edge gasket using the special tool (Fig. 1).
- Completely remove the gasket as shown in Fig. 1; by doing so you also remove the padding.
- Remove the “N-Com” plugs found at the back of the shell gasket and on the left side of the helmet.

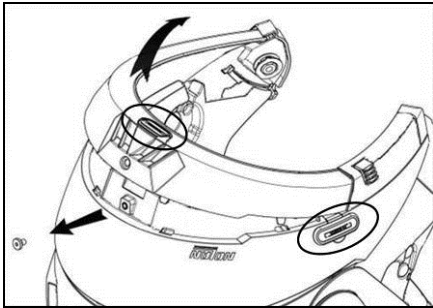

Fig. 1

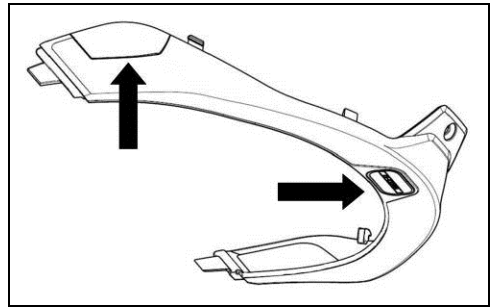
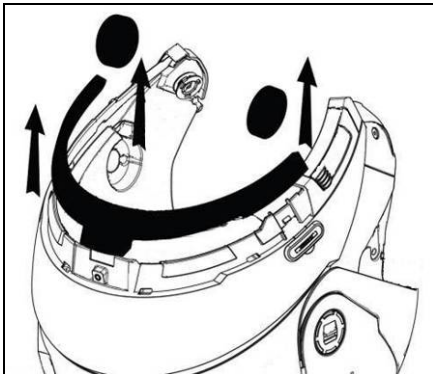
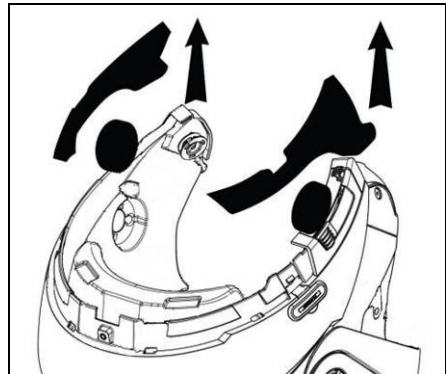

Fig. 1 – ONLY FOR N87 – N105 HELMET

- Prior to installing the N-Com system, remove any filling foam material found in the helmet.



Option 1



Option 2

N.B.: Keep the filling material in case you wish to use the helmet without the N-Com system in the future.

3.1. Preparing the ESS system

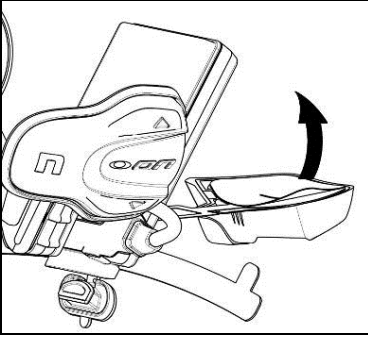

Fig. 2

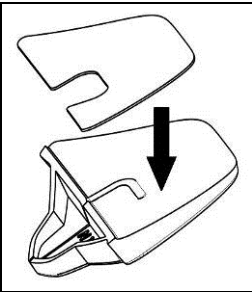

Fig. 3

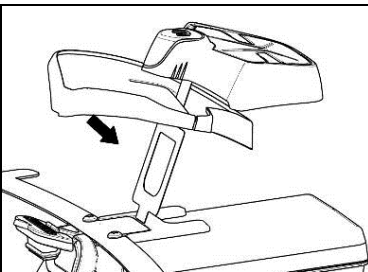

Fig. 4

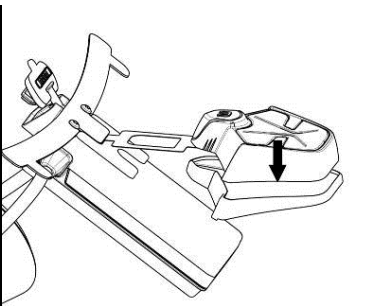

Fig. 5

- Select the specific adapter for your helmet (the compatible helmet model is shown on the back of the support).

N.B.: The installation of the ESS system on N87 and N105 helmets requires no adapter.

- Remove the protective film from the double-sided adhesive tape located in the rear of the system ESS (Fig. 2)

- Apply the double-sided adhesive tape supplied as standard equipment to the selected plastic adaptor (Fig. 3).

- Insert the FLEX cable of the ESS system in the hole of the selected adapter as illustrated, in the direction shown in the image (Fig. 4);

- Rotate the adapter until it is in a horizontal position like the ESS system, then press the two components together until they stick one onto the other (Fig. 5);

3.2. Installing the ESS system on the helmet

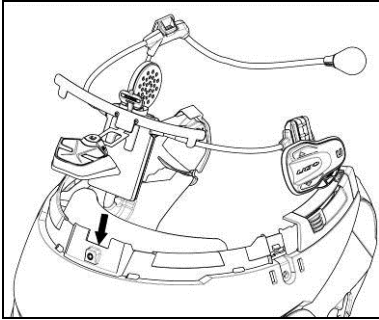

Fig. 6

- Place the system in the special housing in the back of the helmet, pushing it all the way into the groove (Fig. 6).

Important: Make sure the Flex cable is not pulled too tightly.

- Fold the antenna back inside the shell.

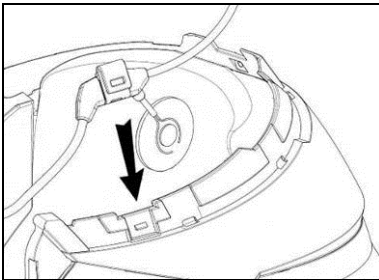

Fig. 7

N.B.: For positioning of the wiring and of the microphone in the N105 helmet, follow the instructions provided in the dedicated box.

- Fix the cable inside the helmet and make sure the right fixing clip snaps into its housing (Fig. 7)

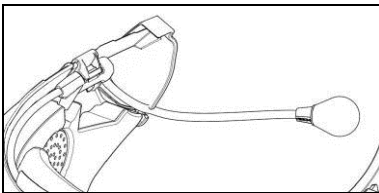

Fig. 8

- Position the microphone in the housing on the left of the helmet, inserting the metal boom in the groove found in the chin guard coupling frame (Fig. 8).

Caution: make sure that the side of the microphone support with the writing "N-Com" is facing inward.

- Fix the cable inside the helmet and make sure the left fixing clip snaps into its housing.

- Hook up the keypad to the helmet by clicking in the relevant hooks.

N.B.: For positioning of the keypad in helmets N87 and N105, follow the instructions provided in the dedicated box.

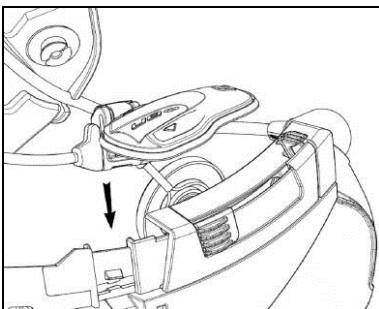

Fig. 9

- Open the rubber cap of the B901L system.
- Reassemble the gasket and secure it with the specific screw.

ONLY FOR HELMET N105 – positioning of wiring and microphone

Positioning the right side wiring and the microphone:

- Lift up the plastic lining of the cheek padding (Fig. 10)
- Insert the microphone into the eyelet (Fig. XX) and position it in the special housing, then inserting the metal boom in the groove found in the chin guard coupling frame (Fig. XX)
Caution: make sure that the side of the microphone support with the writing "N-Com" is facing inward.
- Fix the cable inside the helmet and make sure the right fixing clip snaps into its housing (Fig. XX)
- Reposition the plastic lining of the cheek padding, arranging it behind the two small stop hooks (Fig. XX)

Positioning the left side wiring:

- Lift up the plastic lining of the cheek padding (Fig. XX)
- Fix the cable inside the helmet and make sure the left fixing clip snaps into its housing (Fig. XX)
- Reposition the plastic lining of the cheek padding, arranging it behind the two small stop hooks (Fig. XX)

Fig.

Fig.

FOR N87 – N105 HELMENTS ONLY – positioning the keypad

Important: Installation of the keypad on the N87, N105 helmets requires the use of the “KEYPAD ADAPTER” accessory, which is included in the package.

- Insert the support specific for your helmet in the flex cable of the keypad (Fig. XX);
- Rotate the keypad support so as to position it like in Fig. XX, then hook it to the keypad;
- Fix the cable inside the helmet and make sure the left fixing clip snaps into its housing (Fig. XX);
- Open the rubber cap of the B901L system.
- Reassemble the gasket and secure it with the specific screw;
- Hook up the keypad to the helmet by clicking in the relevant hooks (Fig. XX);
- The proper positioning of the keypad is illustrated in Fig. XX and in Fig. XX.

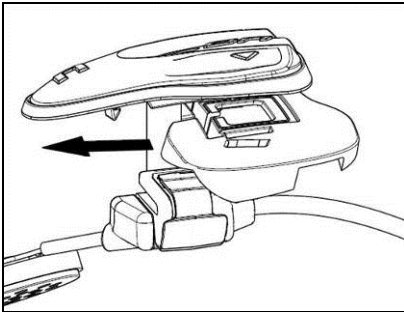

Fig. 10

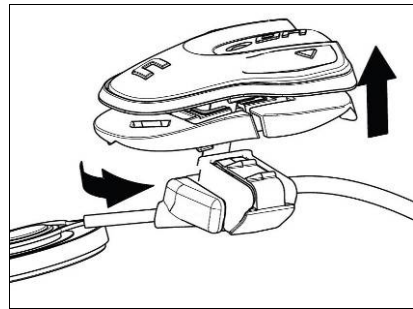

Fig. 11

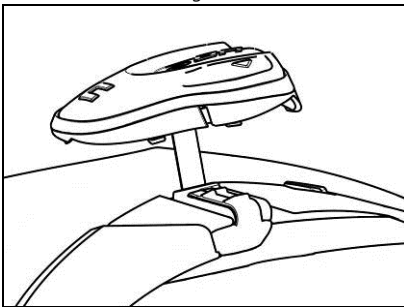

Fig. 12

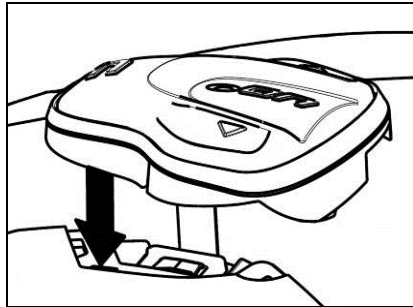

Fig. 13

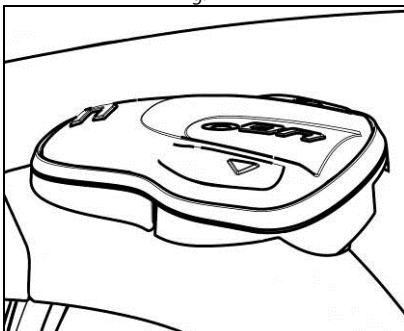

Fig. 14

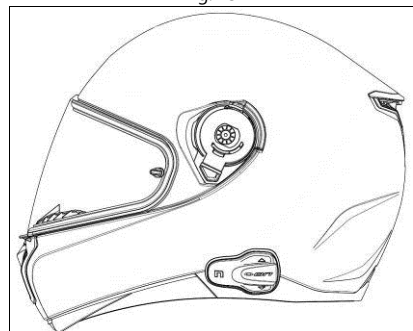

Fig. 15

- Position the left and right speakers in the respective housing obtained in the polystyrene cheek padding. If necessary, rotate the speakers slightly in their housing.
- Reassemble the cheek padding.

3.3. Positioning the ESS system on the helmet

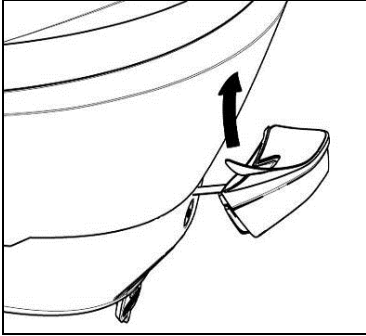

Fig. 16

- Remove the protective film from the double-sided adhesive tape of the helmet adapter (Fig. 16) and apply the ESS system to the shell (Fig. 17).

Attention: Position the “N” of the ESS system at the shell edge gasket screw, so that the adapter is lined up with the helmet lines.

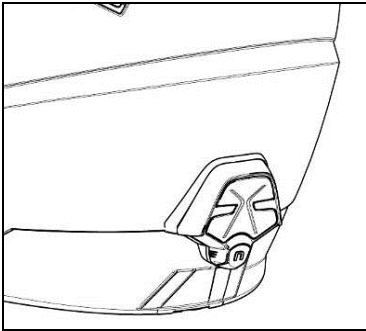

Fig. 17

- Remove the clear protective film from the ESS system.
- Reassemble the cheek padding.

3.4. Removing the B901L system from the helmet

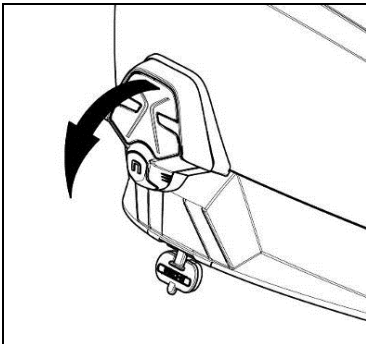

Fig. 18

Proceed as follows to remove the **B901L** system from the helmet:

- Remove the ESS light from the shell (Fig. 18).

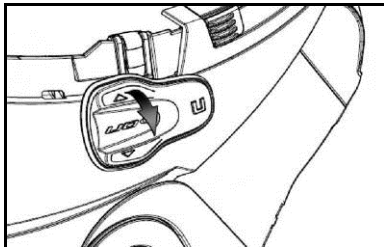

Fig. 19

- Remove the cheek padding and the shell gasket;
- Remove the keypad from the shell, as shown in fig. 19.

FOR N87 – N105 HELMENTS ONLY – removing the keypad

- Remove the keypad from the shell, as indicated in fig. 20.
- Rotate the keypad in a counterclockwise direction (Fig. 21)
- Remove the cheek padding and the shell gasket.

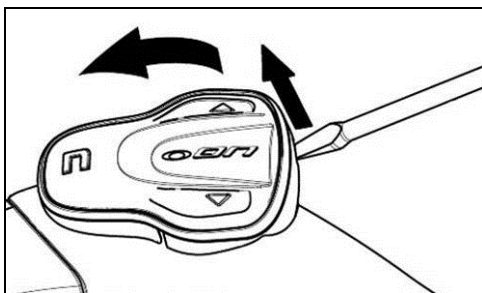

Fig. 20

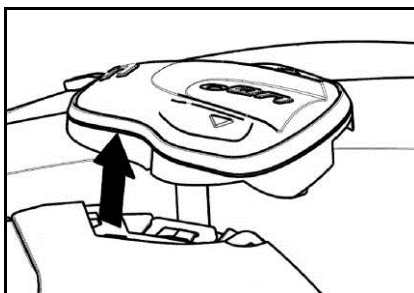

Fig. 21

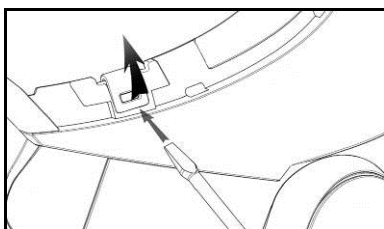

Fig. 22

- Unhook the right and left clips from the shell, levering upward using a flat head screw (or a similar tool), as shown in figure 22.

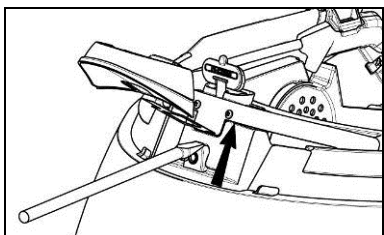

Fig. 23

- Completely remove the B901L system from helmet using a flat head screwdriver (or similar tool) and re-install the cheek padding and the edge gasket.

4. BASIC FUNCTIONS

System ON	Press " ON " and keep it pressed for about 2 seconds, until the LEDs turn on and you hear the voice announcement.
System OFF	Press " ON " and keep it pressed for about 6 seconds, until the LEDs turn off and you hear the voice announcement.

N.B.: during the switch on/switch off phase of the B901L system, the ESS light flashes for a few seconds.

4.1. Volume adjustment

You can easily adjust the volume by tapping the "▲" button or the "▼" button. You will hear a beep when the volume reaches the maximum or minimum level.

The volume is independent for each sound source. Once it is set for a specific source (phone call, radio, Mp3), it will remain in memory even after the system is switched off.

However, if you adjust the volume during stand-by mode, it will affect volume levels of every audio source.

4.2. Auto On / Off function

If the helmet does not move for more than 60 seconds, the **B901L** system goes into "deep sleep" mode. The system is completely turned on as soon as movement is detected.

If the system is in "deep sleep" mode for more than 3 days, it turns off completely. To turn it back on, the "**ON**" key needs to be pressed.

4.3. N-Com EASYSET



"N-Com EASYSET" is the application that can be used to manage and configure the **B901L** system. The programme can be downloaded from the Internet site www.n-com.it, in the "Download" section. The functions that can also be managed from the N-Com EASYSET are listed here below with the specific icon.



The N-Com system can be managed from the dedicated App "N-Com EASYSET", which makes it possible to configure and control the N-Com system directly from your Smartphone.

The N-Com APP can be downloaded free of charge from Google Play or Apple Store.

For additional details, please visit the website www.n-com.it

The functions that can also be managed from the N-Com EASYSET App are listed here below with the specific icon.

5. CONFIGURATION MENU

All Bluetooth pair ups and other adjustments are carried out in this mode.

To put the system in "Configuration mode" (starting from a switched off system) press the "ON" key and keep it pressed for 4 seconds, until the blue LED starts flashing quickly and you hear the voice announcement "*Configuration*".

Once in the "Configuration" menu, press the keys "▲" and "▼" to scroll through the various menu items.

In the items marked with an "*", it is possible to enable / disable the function or carry out the commands by pressing the "ON" key to confirm.

The following items make up the "Configuration" menu:

- A. **Mobile phone pair up** (chapter 6)
- B. **Intercom pair up** (chapter 14)
- C. **Universal Intercom pair up** (chapter 15)
- D. **Second mobile phone pair up** (chapter 8)
- E. **Remote control pair up** (chapter 16)
- F. **Speed dialling*** (chapter 7.1)
- G. **Audio boost ***
By enabling the "Audio boost" (Audio Boost), all the audio sources inside the device will be reproduced at a higher and potentially less clear volume.
Press the "ON" confirmation key to enable / disable the function, which is not enabled by default on the device.
- H. **ESS sensitivity*** (chapter 13.1)
- I. **Delete all pair ups***
In order to delete all Bluetooth pair ups stored in the device, press the key "▲" or "▼" until you hear the voice announcement "*Delete all pair ups*".
Press the "ON" confirmation key to delete all Bluetooth devices stored in memory.
- J. **Reset***
In order to restore the factory settings of the device, press the key "▲" or "▼" until you hear the voice message "*Reset*".
Press the "ON" confirmation key to restore all the factory settings of the device.
- K. **Exiting the configuration***
To exit the "Configuration" menu, press the key "▲" or "▼" until you hear the voice announcement "*Exit the configuration menu*".
Press the "ON" confirmation key to exit the "Configuration" menu.
If no key is pressed within 10 seconds, the device automatically exits the "Configuration" menu.

6. PAIRING UP WITH MOBILE PHONES OR OTHER BLUETOOTH DEVICES

- Make sure the B901L is turned off;
- Put the system in the "Configuration" mode, then press the "ON" key and keep it pressed for 4 seconds until the blue LED starts flashing quickly;
- Press the key "▲" to access the "Mobile phone pair up mode".
- Turn on the search for Bluetooth devices (smartphone, MP3 reader) on the device;
- Select the N-Com device. If a password is requested, enter 0000 (four zeros);
- Connection between the two devices is established after a few seconds.

Note: The affiliation is stored in the helmet and in the cell phone and it is not lost when the two devices are turned off. As a result it needs to be carried out only once.

Automatic Connection	Once the Bluetooth device has been paired up, connection is automatic when the system is turned on.
Manual Connection	In case connection is not automatically initiated after a few seconds, you can connect from the Bluetooth device or by pressing "ON" and keep it pressed for about 2 seconds.

7. MOBILE PHONE

To pair up a mobile phone to the B901L system, follow the procedure illustrated in Chapter 6.

Answering a phone call	Briefly press any key when you hear the incoming call signal.
Vocal answer	When you hear the ringtone, say any word out loud.
Voice call	Press "ON" and keep it pressed for about 2 seconds.
Hanging up/rejecting a phone call	Press "ON" and keep it pressed for about 2 seconds.
Manual phone connection	Press "ON" and keep it pressed for about 2 seconds.

7.1. Speed dialling



Using the N-Com EASYSET program or the N-Com EASYSET App, you can store up to 3 of your favourite numbers, which you will be able to dial from the "Speed Dialling" menu.

Saving the Speed Dialling numbers

To assign one or more speed dialling numbers:

- Put the system in the "Configuration" mode: starting from a switched off system, press the "ON" key and keep it pressed for 4 seconds, until the blue LED starts flashing quickly and you hear the voice announcement "Configuration".
- Press the key "▲" or "▼" until you hear the voice command "Speed dialling".
- Press the "ON" confirmation key. You will hear the voice announcements "Speed dialling 1" and "Phone connected".
- Press the keys "▲" or "▼" to select the speed dialling number to be assigned. The saved position is confirmed by the voice announcement "Speed dialling 1 / "Speed dialling 2" / "Speed dialling 3".

- On your own mobile phone (paired up and connected to the N-Com system), call the phone number you wish to assign to the selected speed dialling position. The call is interrupted before it goes through, and the selected number will be saved; at this point you will hear the special voice announcement confirming the selection ("**Save Speed Dialling 1**" / "**Save Speed Dialling 2**" / "**Save Speed Dialling 3**").



You can also configure these setting through the program "N-Com EASYSET" or through an Android Smartphone, iPhone, iPad on which the "N-Com EASYSET" App has been installed.

Using the stored numbers

To access the "Speed Dialling" menu, press at the same time the "**ON**" and "**N**" keys ("**Speed Dialling**"), then use the keys "**▲**" and "**▼**" to scroll through the menu items.

Then press the "**ON**" key to confirm the selection of one of the following items:

- **Call Last Number Dialed**
- **Speed Dialling 1**
- **Speed Dialling 2**
- **Speed Dialling 3**
- **Cancel**

If you wish to exit the "Speed Dialling" menu, press the keys "**▲**" and "**▼**" until you hear the command "**Cancel**", then press "**ON**" to confirm.

N.B.: If no key is pressed within 15 seconds, the system exits the "Speed Dialling" menu.

7.2. Conference call function

When a call comes in on a mobile phone connected via Bluetooth to **B901L**, the intercom is temporarily turned off. However, if you wish to share the phone call with the other helmet, simply turn on the intercom manually during the phone call.

Turning on the phone conference call function	During the phone call, briefly press " N " (channel 1). During the phone call, press the " N " key twice (channel 2). During the phone call, press the " N " key three times (channel 3).
Turning off the phone conference call function	During the phone call, briefly press " N ".

8. MANAGING TWO MOBILE PHONES (OR BLUETOOTH DEVICES)

The **B901L** system can be hooked up to two phones (or Bluetooth) devices at the same time. The second phone (secondary device) can receive calls but not make them.

To pair up the second Bluetooth phone (secondary device):

- Make sure the B901L is turned off;
- Put the system in the "Configuration" menu: press the "ON" key and keep it pressed for 4 seconds, until the blue LED starts flashing quickly;
- Press the pushbutton "▲" until you reach the option "*Pair up second mobile phone*".
- Turn on the search for Bluetooth devices (smartphone, MP3 reader) on the device;
- Select the N-Com system from the list. If a password is requested, enter the code 0000 (four zeroes);
- After a few seconds, the connection between the two devices is activated.

Once the Bluetooth device has been paired up, connection is automatic when the system is turned on.

9. MUSIC VIA BLUETOOTH

To pair up an Mp3 device to the B901L system, follow the procedure illustrated in Chapter 6.

Play music (Play)	Briefly press "ON".
Pause function (Pause)	When the player is connected and playing music, briefly press "ON".
Next track (Skip)	When the player is playing music, press "▲" for 2 about seconds.
Previous track (Rew)	When the player is playing music, press "▼" for 2 about seconds.

9.1. Sharing music via Bluetooth (*A2DP Sharing*)

During the intercom connection, you can start playing music by briefly pressing the "ON" key. The music will be played in both systems.

Music sharing temporarily cuts off the intercom conversation; however, this can be automatically restored by stopping the music (this is done by briefly pressing the "ON" key).

N.B.: Music shared through the intercom can be managed by both systems, for example, both systems can change the track by pressing the relative command.

10. MUSIC VIA CABLE

Connect the mini USB connector of the Multimedia Wire (not included) to the helmet and the other end to the audio device. A coloured band on the cable indicates the connector to be hooked up to the audio device.

Turning on the cable audio	Press the "ON" key three times.
Turning off the cable audio	Press the "ON" key three times.

11. SATELLITE NAVIGATOR FOR MOTORCYCLES

B901L system is compatible with the most common satellite navigators for motorcycles. For a list of compatible models and additional details, visit the website www.n-com.it

To pair up a satellite navigator to the **B901L** system, follow the procedure illustrated in Chapter 6.

N.B.: Intercom connection is automatically cut off every time the navigator gives directions and restored at the end of the message from the navigator.

13. LED SIGNALLING LIGHTS

The B901L system features a menu with 3 operating modes: EMERGENCY STOP SIGNAL, REAR LIGHT, POOR VISIBILITY LIGHT.

To scroll through this menu, with the system turned on, press keys “▲” and “▼” and keep them pressed for about 2 seconds. Every time you press the key, the system switches to the next mode.

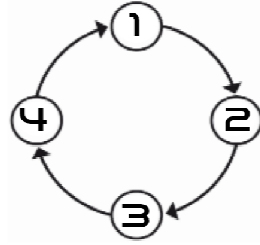

MODE		FUNCTIONS
1	EMERGENCY STOP SIGNAL	Emergency stop signal.
2	REAR LIGHT	Emergency stop signal. Stable rear light.
3	POOR VISIBILITY LIGHT	Emergency stop signal. Intermittent light in case of poor visibility.
4	SWITCH OFF	Complete switch off of LED lights

13.1. Emergency Stop Signal ESS (mode 1)

The B901L system is equipped with a LED system to assist emergency braking. In case of sudden braking, the LEDs on the B901L flash for a few seconds.



The braking level can be adjusted using the “N-Com EASYSET” programme or through the “N-Com EASYSET App” for Smartphone Android, iPhone, iPad.

N.B.: We recommend turning off the Emergency Stop Signal on the Rider’s helmet in case a Pillion Passenger is riding on the back.

ESS sensitivity adjustment

Put the system in the “Configuration” mode: from a switched off system, press the “ON” key and keep it pressed for 4 seconds, until the blue LED starts flashing and you hear the voice announcement “*Configuration*”.

To adjust the sensitivity of the ESS lamp, press the key “▲” or “▼” until you hear the voice announcement “*ESS sensitivity*”, then press the “ON” confirming. Afterwards, press the key “▲” or “▼” to select the desired sensitivity level:

Level 1: low sensitivity, the ESS system will only detect significant braking.

Level 2 (default): average sensitivity.

Level 3: high sensitivity, the ESS system will also detect slight braking.

13.2. Rear Light (mode 2)

The tail light makes it possible to activate the LEDs of the system, keeping them on during the entire ride.

If the emergency brake light is activated during braking, all LEDs will start flashing.

13.3. Poor visibility light (mode 3)

The poor visibility light allows you to be more visible in case of fog or limited visibility. If selected, the LEDs of the system will flash intermittently.

If the emergency brake light is activated during braking, all LEDs will flash more quickly.

14. N-COM INTERCOM (SERIES "900")

The N-Com B901L system allows communication with other N-Com systems, up to a distance of about 700 m (in open field, with no obstacles).

Important: The procedure described below refers exclusively to the pairing up and operation between the B901L and the "900" series N-Com systems.

To pair up to N-Com systems of a range other than the "900" series, please refer to the procedure described in chapter 15 "Universal Intercom".

N.B.: The range and quality of the communication may vary significantly depending on the presence of obstacles, weather conditions, magnetic fields.

N.B.: The range of the communication varies depending on the N-Com systems used.

14.1. Intercom pairing up

- Make sure the B901L is turned off;
- Put the systems in "Configuration" mode: press the "ON" key and keep it pressed for 4 seconds, until the blue LED starts flashing;
- On both systems, press the key "▲" until you reach the option "*Intercom pair up*";
- On system A, press the key pertaining to the "pre-setting position" where you wish to save system B.

Pairing up CHANNEL 1	Briefly press "N".
Pairing up CHANNEL 2	Press the "N" key twice.
Pairing up CHANNEL 3	Press the "N" key three times.

The Intercom connection with the selected channel is automatically activated at the end of the pair up procedure.

14.2. Intercom function (one-to-one connection)

To establish an Intercom connection with one of the systems stored in memory, simply press the command related to the channel where the system was saved.

Connection CHANNEL 1	Briefly press "N".
Call CHANNEL 2	Press the "N" key twice.
Call CHANNEL 3	Press the "N" key three times.
Disconnection of active intercom	Briefly press "N".

The B901L system is equipped with the VOX function, which makes it possible to switch the intercom on and off vocally. Once the intercom is manually activated for the first time, the B6L system detects your voice and automatically activates/deactivates the communication.



You can enable / disable the "VOX" function and set the activation sensitivity, using the N-Com EASYSET program or the N-Com EASYSET APP.

The VOX function is disabled by default on the device.

N.B.: In case the pre-setting position is empty, or the system being called cannot be reached within the maximum range or it is already engaged in a phone call, you will hear an error voice message.

N.B.: In case the Intercom connection system falls outside the range (Intercom connection interrupted), the B901L system will automatically try to reconnect every 8 seconds. Double beeps will be emitted until the Intercom connection is not restored.

If you do not want automatic reconnection, press the "ON" key to stop the automatic reconnection attempts.

14.3. Smart Conference (Group Intercom)

Thanks to the "Smart Conference" function, you can start the conference communication between N-Com intercom systems of the "900" series previously paired up and saved in the 3 available channels. All systems must be turned on and available within the connection range.

1. Each system must have been previously paired up to all the other systems: B, C and D.

←-----→ AFFILIAZIONE

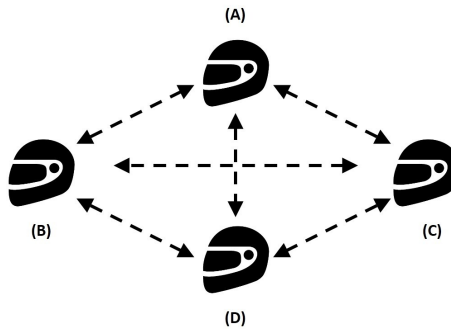

2. Any system can press the "N" key for 2 seconds to activate the Group Conference or to start a conference communication between all the systems.

←-----→ CONNESSIONE

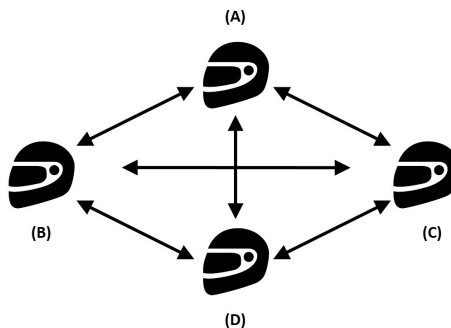

3. In the case where one of the systems presses the “N” key or falls outside the connection range, the group intercom is interrupted.

Smart Conference connection	Press the “N” key for 2 seconds. Activation is confirmed by a beep in the helmet and by the voice message “ <i>Group Intercom</i> ”.
Smart Conference disconnection	Briefly press the “N” key. Disconnection is confirmed by the voice announcement “ <i>Group Intercom ended</i> ”.

N.B.: During a “Smart Conference” call, connection to the mobile phones of all participants is temporarily cut off. When the conference call ends, all phones automatically reconnect to their own intercom system.

15. “UNIVERSAL INTERCOM” INTERCOM

The N-Com B901L system can be connected via Bluetooth to intercom systems of other brands or to N-Com systems other than the “900” series, thanks to the UNIVERSAL INTERCOM function.

Important: N-Com systems other than the “900” series must be paired up to the N-Com B901L by following the procedure “*Pairing up the Universal Intercom*”.

Caution: Visit the www.n-com.it website for the list of compatible N-Com systems.

15.1. Pairing up the UNIVERSAL INTERCOM

The N-Com system can be paired up to the other intercom (from now on referred to as Intercom B) as if it was a mobile phone.

1. Make sure the B901L is turned off;
2. Put the system in the “Configuration” mode: press the “ON” key and keep it pressed for 4 seconds, until the blue LED starts flashing;
3. Press the pushbutton “▲” until you reach the option “*Universal intercom pair up*” mode.
4. Put intercom B in the mobile phone pairing up mode (refer to the Intercom B manual);
5. After a few seconds, Intercom B will emit the “phone connection” confirmation beep;

N.B.: The system paired up using the UNIVERSAL INTERCOM is saved in the first available channel.

15.2. Universal Intercom Function

To turn on and off the audio between two helmets, proceed as follows:

From the N-Com B901L system:

Connect or disconnect Intercom B as you would for a regular N-Com intercom (chapter 14). Intercom B may receive a dialing one that must be answered with a phone reply command.

From intercom B

Press the "Voice call / Dial last number called" command.

To disconnect the intercom, press "Voice call / Dial last number called" once again.

N.B.:

- The N-Com B901L systems keeps an active connection with a mobile phone even during Bluetooth communication with other intercom systems.
- The intercom system connected to N-Com B901L may not allow simultaneous connection to a mobile phone.
- Only one system paired up in Universal Intercom mode can be stored.

15.3. Universal Conference (chain intercom)

The "Universal Conference" mode can be used to connect in conference call N-Com systems of the "900" series and one system paired up in Universal Intercom mode.

N.B.: This mode can also be used by connecting only N-Com "900" series systems, in alternative to the "Smart Conference" mode (chapter 14.3).

The connection procedure is outlined in the diagram provided here below:

1. System A must have been paired up beforehand to two B systems (Universal Intercom pair up) and C.

←-----→ AFFILIAZIONE

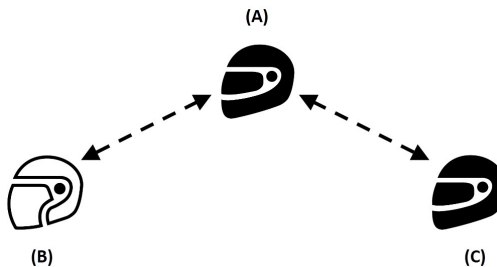

2. System A has to initiate the first intercom connection with system B (Universal Intercom), by pressing the relative intercom connection command.

←-----→ AFFILIAZIONE
 ←-----→ CONNESSIONE

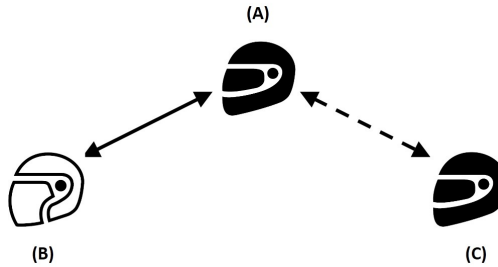

3. At this point, system C can join the intercom conference call, establishing an intercom connection with system A.

←→ CONNESSIONE

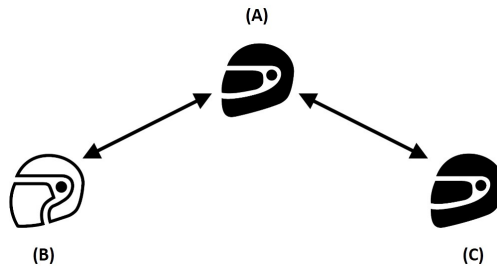

4. The three systems are not in intercom conference call mode and can talk to each other at the same time. All intercom conference call systems can be disconnected by briefly pressing the "N" command on any one of the devices connected in conference call.
5. In case you wish to add another system (D), the latter must be paired up beforehand to system C. Press the relative connection command to start a 4-participant intercom conference call.

N.B.: The "Universal Conference" mode (chapter 14.3) CANNOT be used with systems paired up in Universal Intercom mode.

16. REMOTE CONTROL

The B901L device can be controlled through a remote control (sold separately), thus avoiding the need to take your hands off the handlebars to use the keyboard.

Please refer to the specific operating instructions of the Remote Control in order to use its various functions.

17. BATTERY AND RECHARGE

17.1. Low battery signal

During its operation, the system alerts the user with a voice message when the battery is low. From the first message, the system has a 1-hour autonomy. Warning is given every 10 minute.

17.2. Charging the system

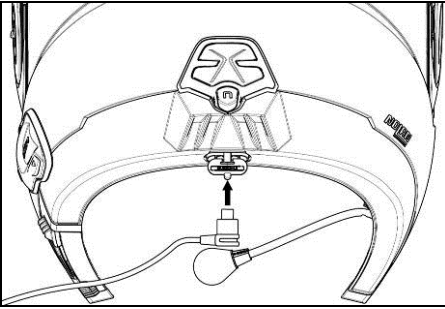

- To charge the system, hook it up to the battery charger or to a USB outlet powered with the USB-mini USB cable supplied as standard equipment. The charge will take place as follows:

B901L system turned off	When the B901L system is connected to the battery charger, the blue LED starts to flash quickly. When the battery is charged, the blue LED becomes steady.
B901L system turned on	When the B901L system is connected to the battery charger, the blue LED starts to flash quickly. When the battery is charged, the blue LED goes back to its standard flashing.

N.B.: If the device has not been charged for a long time (a few months), it may not be possible to turn on the system during the first few minutes of the charging, as the voltage may drop below the minimum limit.

18. SUMMARY TABLE OF CONTROLS

<i>Button</i>		N	ON	▲	▼	▲ + ▼
Basic Functions	Turning on		2 sec			
	Turning off		6 sec			
	Increase Volume			X		
	Decrease Volume				X	
	Management of Lights Menu					2 sec

Bluetooth Devices	Answer phone call*	X	X	X	X	
	Voice call		2 sec			
	Speed Dialling Menu**	X	X			
	Hang up/reject a phone call		2 sec			
	Manual Device Connection		2 sec			
	Phone Conference Activation CHANNEL 1	X				
	Phone Conference Activation CHANNEL 2	x2				
	Phone Conference Activation CHANNEL 3	x3				
	Turning off the Conference function	X				

Bluetooth Music / Cable	Play music (Play)		X			
	Pause Function (Pause)		X			
	Next track (Forward)			2 sec		
	Previous track (REW)				2 sec	
	Share A2DP music		X			
	Activate audio via cable		x3			
	Deactivate audio via cable		x3			

<i>Button</i>		N	ON	▲	▼	▲ + ▼
N-Com Intercom (900 series)	Connection CHANNEL 1	X				
	Disconnection of active intercom	X				
	Calling CHANNEL 2	x2				
	Calling CHANNEL 3	x3				
	Group intercom connection	2 sec				
	Group intercom disconnection	X				

Radio Menu	Turning on the Radio		x2			
	Turning off the Radio		x2			
	Automatic search for new station			2 sec		
	Change station (pre-set stations)				2 sec	
	Pre-set station				4 sec	

Setting***	Pairing up mode (system turned off)		4 sec			
	Pairing up secondary mobile phone (or device)		2 sec			
	Pairing up CHANNEL 1 ("900" series)	X				
	Pairing up CHANNEL 2 ("900" series)	x2				
	Pairing up CHANNEL 3 ("900" series)	x3				
	Reset					4 sec

*Press any key on the N-Com keypad.

**Press the keys at the same time.

***All the Setting functions must be carried with the system in Setting Mode.

19. LIMITED WARRANTY

With this LIMITED WARRANTY CERTIFICATE, Nolangroup warrants this Product to be free from defects in material and workmanship at the time of its original purchase by the buyer.

We invite you to:

- Read the cautions pertaining to safety and proper use.
- Read the warranty terms and conditions.
- Keep the originals sales receipt. This must be shown in case of repairs covered by warranty. In these cases, the product has to be taken back to the dealer where it was purchased.

19.1. Warranty coverage

If any defect covered by this limited warranty certificate is discovered within 2 (two) years from the purchase date shown on the tax receipt, Nolangroup shall repair or replace the defective product through its distribution network after having verified the defect. Nolangroup shall supply all the material and labor that is reasonably required to remedy the defect, except in those cases where the damage is caused by one of the items listed in the following paragraph "Exclusions and limitations of the Coverage".

19.2. Exclusions and limitations of the coverage

This warranty only covers defects in materials and manufacturing. Nolangroup shall not be considered responsible for product defects that can be attributed, either partially or in full, to any other cause, including but not limited to:

- Defects or damages resulting from using the Product in conditions that differ from the usual ones.
- Damages caused by improper use not conforming with normal operation in accordance with the product operating and maintenance instructions provided by Nolangroup.
- Negligence and normal wear of internal and external parts.
- Any damage caused by an accident;
- Any change or modification made to the helmet or to the N-Com system by the user or by third parties.
- Colour changes or damages caused by exposure to harmful chemical products.
- The use of incompatible accessories that are not part of the N-Com product range.
- Moreover, the warranty does not cover product defects caused by fortuitous events, modifications or adjustments, causes of force majeure or damages deriving from the product coming in contact with liquids.
- The internal helmet components are not and cannot be waterproof. Consequently, any improper exposure to rain, humidity, food spillages or other liquids can result in damages to the N-Com electronic devices, damages for which Nolan shall not be responsible.
- This warranty does not include those parts subject to wear and tear such as, for example, the rechargeable battery and the cables used for connection between the various N-Com systems or between the N-Com systems and other devices.
- Since Nolangroup does not supply the system on which the cell phones work, it shall not be responsible for the operation, availability, coverage, services or range pertaining to the aforementioned system.
- Whenever the product is used in conjunction with accessories or equipment not supplied by Nolangroup, Nolangroup shall not guarantee proper operation of the product/device combination, nor will it accept requests for repairs or replacements under warranty in case the product is used in such a way.

Nolangroup shall not be responsible in case the product presents limited capabilities due to the operating mode of cell phones or of other accessories or equipment not supplied by Nolangroup.

Tampering with the internal electronic card or with other parts of the N-Com system shall invalidate the warranty.

Moreover, the defects covered by this warranty do not include all those specific and subjective situations that may come up during the active use of the helmet such as, for example, comfort problems while riding or aerodynamic noises.

Nolangroup shall not be held responsible in any case for incidental or consequential damages (including, without any limitation whatsoever, damages to one or more persons) resulting from non-fulfilment of the obligations arising from this warranty as it pertains to Nolangroup products.

19.3. Validity of this limited warranty

This warranty is valid only if the enclosed warranty form is duly and completely filled out with the following information:

Product identification code

Name and stamp of the authorized dealer.

Product purchase date.

Buyer's name and address.

Nolangroup reserves itself the right to not carry out repairs under warranty if the aforementioned information is removed or modified after the original purchase of the product from the dealer.

19.4. Procedure for the forwarding of claims

To forward a claim covered by this warranty, the buyer has to directly notify the dealer where the helmet was purchased with regards to the defect, presenting at the same time the defective product, a copy of the sales receipt and the Warranty registration form, duly filled out as instructed above.

PRIOR TO CONTACTING THE DEALER, WE RECOMMEND THAT YOU READ CAREFULLY THE USER MANUAL ENCLOSED WITH THE PRODUCT.

AFTER 2 (TWO) YEARS FROM THE DATE OF PURCHASE, THIS LIMITED WARRANTY IS VOID FOR ALL EFFECTS AND PURPOSES.

Repairs or maintenance under warranty do not extend the period of the warranty itself. Therefore, in case the product or one of its components is replaced, this does not initiate a new warranty period, as the purchase date of the original product shall be taken into account for warranty purposes.

Only for repairs or replacement of electronic components, in the event that Nolangroup proceeds to repairing or replacing the product, said product shall enjoy a warranty period equal to the residual portion of the original warranty or ninety (90) days from the repair date (the longer period being considered).

The repair or replacement can be carried out even with regenerated components with equivalent functions.

The replaced parts or components shall become property of Nolangroup.

THIS WARRANTY VOIDS AND REPLACES ANY OTHER WRITTEN OR VERBAL WARRANTIES PROVIDED FOR BY THE LAW THAT CAN BE DEROGATED AT THE PARTIES' WILL; SPECIFICALLY, NOLANGROUP DOES NOT GRANT SPECIFIC WARRANTS OF MERCHANTABILITY OR FITNESS FOR A PARTICULAR PURPOSE. IN NO CASE SHALL NOLANGROUP BE LIABLE FOR INCIDENTAL OR CONSEQUENTIAL DAMAGES INCLUDING BUT NOT LIMITED TO LOST PROFITS OR COMMERCIAL DAMAGES, TO THE FULL EXTENT THOSE DAMAGES CAN BE DISCLAIMED BY THE LAW.

NOLANGROUP RESERVES ITSELF THE RIGHT TO MODIFY, AT ANY TIME AND WITHOUT ADVANCE NOTICE, THE PRODUCT CHARACTERISTICS, FUNCTIONS, COMPATIBILITY AND SOFTWARE.

Some Countries do not allow the exclusion or limitation of incidental or consequential damages, or the limitation of the duration of implied warranties; as a result of this, the previous limitations and exclusions may not be applicable to you.

This warranty does not have any effect on the customer's legal rights under the national jurisdiction in force or on the consumer's rights towards the dealer sanctioned by the purchase/sale contract.

This warranty is valid throughout the European territory, and it represents the only express warranty provided by Nolangroup in relation to the sale of its own products. This warranty does not affect the rights to which the buyer is entitled and which are expressly provided for by Directive 1999/44/CE.

This warranty does not affect the consumer's rights provided for by the law, and specifically by the provisions of Legislative Decree 2 February 2002 n. 24.

19.5. Product identification

N-Com products are identified by means of a code that allows product traceability and identification.

The identification code is listed on the adhesive label applied to the B901L system and on the outside of the sales package.

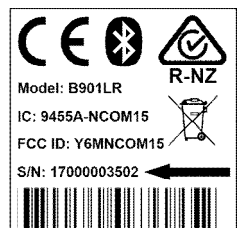

20. WARRANTY REGISTRATION FORM

Product name

B901L

Identification code

--	--	--	--	--	--	--	--	--	--	--	--	--	--	--

Buyer's Information

Name

Last name

Address

Phone

e-mail

Dealer's stamp

Date of purchase

Certification and Safety Approvals

FCC Compliance Statement

This device complies with part 15 of the FCC rules.

Operation is subject to the following two conditions:

- (1) This device may not cause harmful interference, and
- (2) This device must accept any interference received, including interference that may cause undesired operation.

This equipment has been tested and found to comply with the limits for a Class B digital device pursuant to part 15 of the FCC rules. These limits are designed to provide reasonable protection against harmful interference in a residential installation. This equipment generates, uses and can radiate radio frequency energy and, if not installed and used in accordance with the instructions, may cause harmful interference to radio communications. However, there is no guarantee that interference will not occur in a particular installation. If this equipment does cause harmful interference to radio or television reception, which can be determined by turning the equipment on and off, the user is encouraged to try to correct the interference by one or more of the following measures:

- Reorient or relocate the receiving antennae
- Increase the separation between the equipment and the receiver
- Connect the equipment into an outlet on a circuit different from that to which the receiver is connected.
- Consult the dealer or an experienced radio/TV technician for help.

FCC RF Exposure Statement

This equipment complies with FCC radiation exposure limits set forth for an uncontrolled environment. End users must follow the specific operating instructions for satisfying RF exposure compliance. The antenna used for this transmitter must not transmit simultaneously with any other antenna or transmitter, except in accordance with FCC multi-transmitter product procedures.

FCC Caution

Any changes or modifications to the equipment not expressly approved by the party responsible for compliance could void user's authority to operate the equipment.

Certification et homologation de sécurité

Déclaration de conformité FCC

Cet appareil est en conformité avec la partie 15 des règles de la FCC. Son fonctionnement est soumis aux deux conditions suivantes :

- (1) Cet appareil ne doit pas créer d'interférences préjudiciables et
- (2) Cet appareil doit accepter toutes les interférences reçues, y compris celles qui pourraient entraver son bon fonctionnement. Cet équipement a été testé et jugé conforme aux limites pour

un appareil numérique de classe B, conformément à la partie 15 des règles de la FCC. Ces limites sont conçues pour fournir une protection raisonnable contre les interférences nuisibles dans une installation résidentielle. Cet équipement génère et utilise de l'énergie radio fréquence et, s'il n'est pas installé et utilisé conformément

aux instructions, il peut occasionner des interférences nuisibles au niveau des communications radios. Cependant, il n'existe aucune garantie que ces interférences ne se produiront pas dans une installation particulière. Si cet équipement génère des interférences nuisibles à la réception de la radio ou de la télévision (ce qu'il est possible de déterminer en mettant l'équipement hors tension, puis sous tension), l'utilisateur est invité à suivre une ou plusieurs des mesures suivantes pour corriger le problème des interférences en prenant l'une des mesures suivantes :

- Modifier l'emplacement ou l'orientation de l'antenne de réception.
- Éloigner l'appareil du récepteur.
- Brancher l'appareil sur une prise située sur un circuit différent de celui du récepteur.
- Consulter le revendeur ou un technicien expérimenté pour obtenir de l'aide.

É noncé FCC sur l'exposition aux radiations RF

Cet équipement est conforme aux réglementations FCC d'exposition aux radiations définies pour un environnement non contrôlé. Les utilisateurs doivent respecter les instructions d'exploitation spécifiques pour répondre aux exigences de conformité sur l'exposition aux RF. L'antenne utilisée pour cet appareil ne doit pas fonctionner en même temps qu'une autre antenne ou émetteur, sauf s'il y a conformité avec les procédures FCC des produits multi-émetteurs.

Précautions FCC

Tout changement ou modification non expressément approuvé par la partie chargée de la mise en conformité peut annuler le droit de l'utilisateur à utiliser l'équipement.

Industry Canada Statement

This device complies with Industry Canada license-exempt RSS standard(s).

Operation is subject to the following two conditions:

- (1) This device may not cause interference.
- (2) This device must accept any interference, including interference that may cause undesired operation of the device.

Déclaration de conformité IC (Industrie Canada)

Le présent appareil est conforme aux CNR d'Industrie Canada applicables aux appareils radio exempts de licence. L'exploitation est autorisée aux deux conditions suivantes :

- (1) Cet appareil ne doit pas créer d'interférences.
- (2) Cet appareil doit accepter toutes les interférences reçues, y compris celles qui pourraient entraver son bon fonctionnement.