

NUR-05WL2 IMPLEMENTATION GUIDE

Change history

Version	Date	Author	Remarks
0.1	2.1.2013	Toni Heijari	initial version
0.2	6.3.2013	Toni Heijari	minor additions
0.3	4.4.2013	Toni Heijari	changed sections 1.3 and 4.1
1.0	12.6.2013	Toni Heijari	first released version
1.1	2.9.2013	Toni Heijari	Changed section 11.2 and 11.3

Table of contents

1	GENERAL DESCRIPTION	5
1.1	Block diagram.....	5
1.2	Key features	5
1.3	Typical application schematics.....	6
2	ELECTRICAL CHARACTERISTICS.....	7
2.1	Absolute maximum ratings.....	7
2.2	DC characteristics	7
2.3	RF characteristics.....	7
2.4	Performance characteristics.....	8
3	PIN ASSIGNMENTS.....	9
3.1	Pin designation.....	9
3.2	Pin mapping.....	9
3.3	Signal description	10
4	OEM DESIGN CONSIDERATIONS	12
4.1	RF output and antenna requirements	12
4.2	Power supply	12
4.3	USB device port	13
5	RF PARAMETERS.....	14
5.1	TX level.....	14
5.2	Receiver sensitivity.....	14
5.3	Leakage cancellation.....	14
5.4	Modulation	15
5.5	Link frequency	15
5.6	RX encoding (Miller encoding)	15
5.7	Region	16
6	READING PARAMETERS.....	18
6.1	Q-value	18
6.2	Session.....	18
6.3	Rounds	19
6.4	Selecting the right reading parameters	19
7	GPIO CONFIGURATIONS	21
7.1	Input / output.....	21
7.2	Predefined functions.....	21
8	DIAGNOSTIC FUNCTIONS.....	24
8.1	Reflected power measurements.....	24

8.2	Channel scanner	24
8.3	Received signal strength (RSSI)	24
9	DIMENSIONS	25
9.1	Mechanical dimensions	25
9.2	Land pattern	27
9.3	Paste stencil	28
9.4	Packing tray dimensions	29
10	SMT ASSEMBLY PROCESS AND THERMAL PROCESSING	31
10.1	Storage conditions.....	31
10.2	Soldering process.....	32
11	REGULATORY AGENCIES INFORMATION	34
11.1	European Union and EFTA countries	34
	User's Guide Requirements	34
	Labeling Requirements.....	37
	Approved Antennas	37
11.2	FCC	38
	User's Guide Requirements	39
	Labeling Requirements.....	39
	Approved Antennas	40
11.3	Industry Canada	40
	Labelling Requirements for the Host device	41
	Certified Antennas	41
11.4	Industrie Canada	42
	Exigences applicables aux appareils hôtes.....	42
	Types d'antennes acceptables.....	42

1 GENERAL DESCRIPTION

NUR-05WL2 is a next generation compact UHF RFID reader / writer module. It is compatible with ISO18000-6C (EPC C1G2) standard. Module fulfills ETSI, FCC and IC radio regulations. It is also compatible with DRM (dense reader mode) requirements. Maximum output power is +27dBm and it can be adjusted via SW API with 1 dB steps. Maximum sensitivity is -80dBm.

1.1 BLOCK DIAGRAM

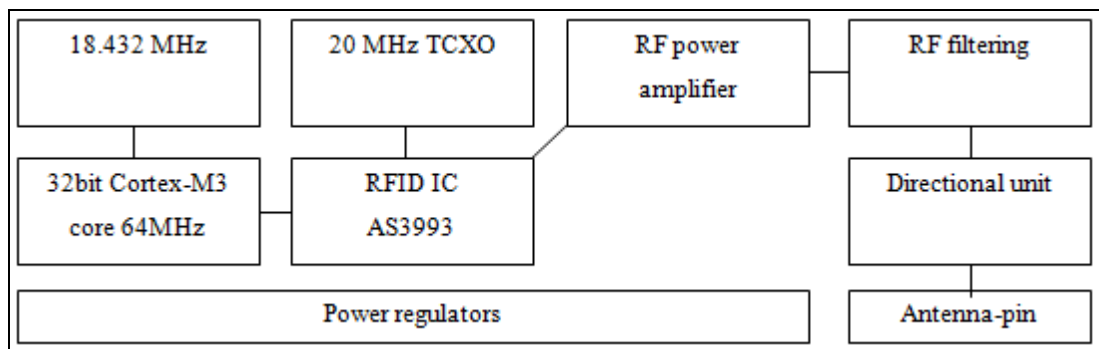

1.2 KEY FEATURES

- SMT compatible module with extremely small footprint
- ISO 18000-6C (EPC C1G2) full protocol support + custom commands
- Low power consumption with high noise rejection
- DRM compatible
- High performance with +27dBm output power, adjustable by 1dB steps
- Approved by ETSI, FCC and IC telecommunication organizations
- Selectable RF parameters; RX coding, link frequency and modulation
- UART and USB 2.0 communication
- 5 programmable GPIO with event trigger
- Autosensing inventory parameter support
- Increased sensitivity with automatic leakage cancelation

1.3 TYPICAL APPLICATION SCHEMATICS

Typical application schematic including: USB connection with ESD protection circuitry, 2 GPIO outputs for LED indicators, GPIO trigger input, NUR-05WL2 module and MMCX antenna connector.

A simple application schematic.

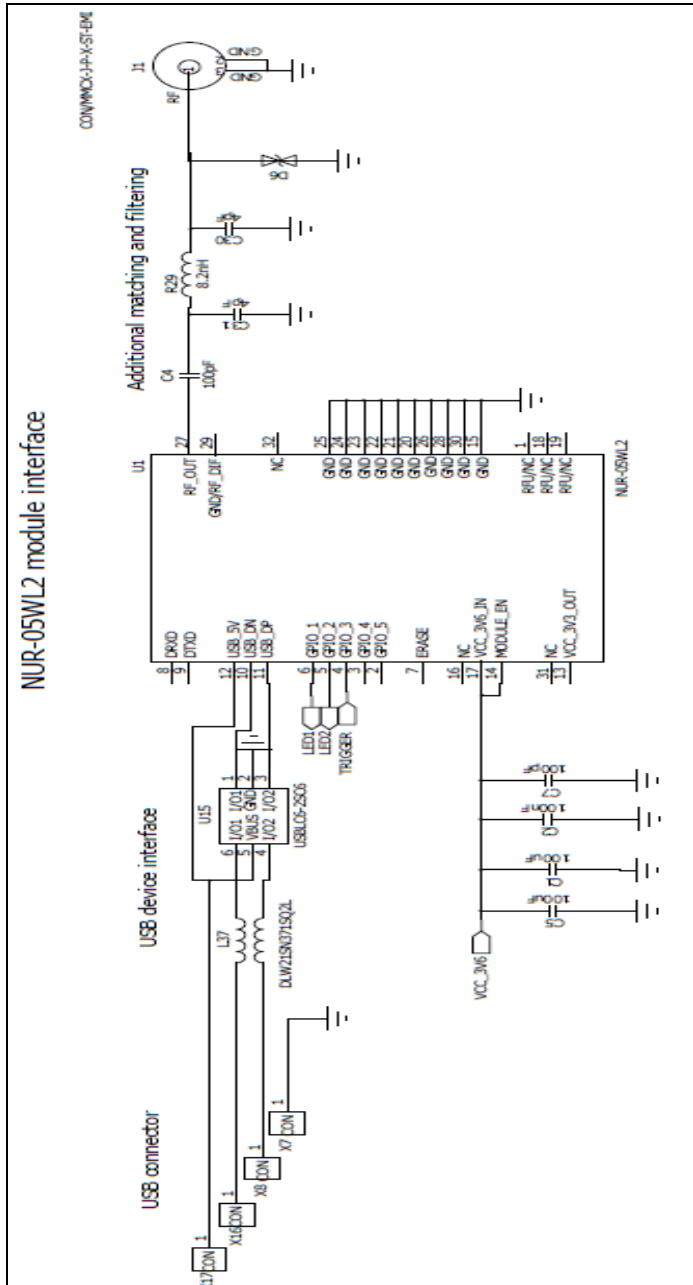

2 ELECTRICAL CHARACTERISTICS

2.1 ABSOLUTE MAXIMUM RATINGS

Violating these values may cause damage to the module. Also correct operation is not guaranteed if operating outside these values. NUR-05WL2 is ESD sensitive component so it must be handled with care.

Absolute maximum ratings	Value
Operating temperature	-20°C to +55°C
Storage temperature (package unopened)	-30°C to +85°C
Supply voltage and enable	+6.0V
GPIO pins	+4.0V
Other pins	+4.0V

2.2 DC CHARACTERISTICS

Typical values (VCC_3V6_IN = 3.6V @ +25°C)

Symbol	Parameter	Min	Typ	Max	Units
V _{ext}	Supply voltage	3.4	3.6	5.5	V
I _{ext}	Supply current	-	0.8A	1A	mA
I _{source}	GPIO source current	-	-	3	mA
I _{sink}	GPIO sink current	-	-	6	mA
V _{low}	GPIO input low-level voltage	-	-	0.8	V
V _{high}	GPIO input high-level voltage	2.0	-	-	V
V _{en}	Module enable voltage	1.2	-	Supply	V

2.3 RF CHARACTERISTICS

Typical values (VCC_3V6_IN = 3.6V @ +25°C)

Symbol	Parameter	Min	Typ	Max	Units
S _{ens}	Receiver sensitivity (data sensitivity PER=0.1% / LBT sensitivity)	-	-	-70/-80	dBm
P _{out}	Output power	8±2	-	27±2	dBm
P _{adj}	Power adjustment step	-	1	-	dB
S ₁₁	VSWR requirement	-	-	1,5:1	@50Ω
D _{r→t}	Reader to tag data rates	-	40 / 80	-	kbps
D _{t→r}	Tag to reader data rates	20	64	320	kbps

2.4 PERFORMANCE CHARACTERISTICS

The performance of the reader module is highly dependent on the test environment, reader antenna and tag performance. Interferences from other radio sources operating in the same frequency may decrease the performance. Also the tag antenna and the tag IC may have significant effect on the values presented below. Also selected radio and inventory parameters have got a big influence to reading performance.

Typical values (VCC_3V6_IN = 3.6V @ +25°C)

Symbol	Parameter	Min	Typ	Max	Units
R _{dist}	Typical reading distance with 5 dBi antenna	-	5	-	m
R _{rate}	Typical reading rate	-	200	-	tags/s
O _{temp}	Operation temperature	-20	-	+55	°C
H _{rel}	Relative humidity	10	-	95	%

3 PIN ASSIGNMENTS

3.1 PIN DESIGNATION

Through top view.

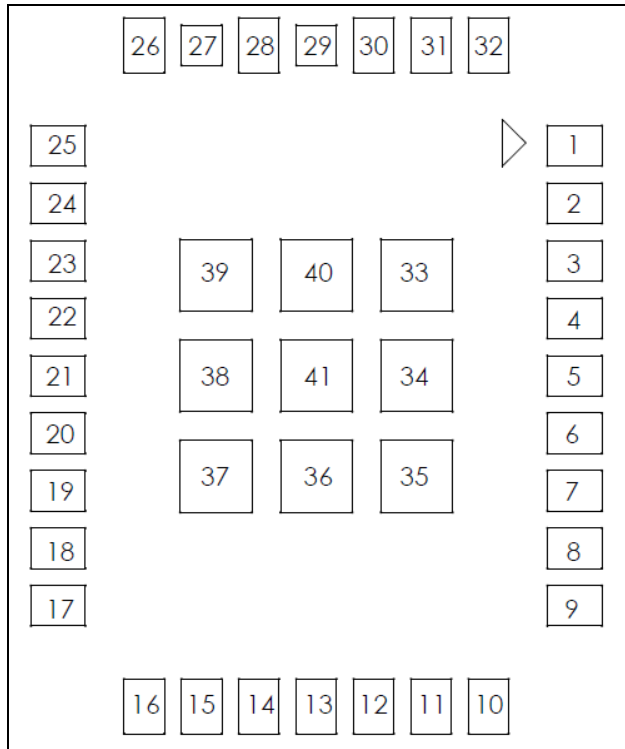

3.2 PIN MAPPING

Pin number	Signal name	Pin type	Description
1	RFU	Bidirectional	RFU (do not connect)
2	GPIO_5	Bidirectional	3.3V GPIO
3	GPIO_4	Bidirectional	3.3V GPIO
4	GPIO_3	Bidirectional	3.3V GPIO
5	GPIO_2	Bidirectional	3.3V GPIO
6	GPIO_1	Bidirectional	3.3V GPIO
7	ERASE	Input	DNU (do not use)
8	RX	Input	Data from Host to Module
9	TX	Output	Data from module to Host
10	USB_DN	Bidirectional	USB – (device port)
11	USB_DP	Bidirectional	USB + (device port)

12	USB_DET	Input	Used only for USB detection
13	VCC_3V3_OUT	Supply output	DNU (only for testing purposes)
14	MODULE_EN	Input	Driving high will enable the module
15	GND	Supply input	Ground
16	NC	Not connected	internally not connected
17	VCC_3V6_IN	Supply input	Supply voltage input
18	RFU	Bidirectional	RFU (do not connect)
19	RFU	Bidirectional	RFU (do not connect)
20	GND	Supply input	Ground
21	GND	Supply input	Ground
22	GND	Supply input	Ground
23	GND	Supply input	Ground
24	GND	Supply input	Ground
25	GND	Supply input	Ground
26	GND	Supply input	Ground
27	RF_OUT	Bidirectional	50Ω RF output/input
28	GND	Supply input	Ground
29	GND/RF_DIF	Bidirectional	RFU (do not connect)
30	GND	Supply input	Ground
31	NC	Not connected	internally not connected
32	NC	Not connected	internally not connected
33-41	GND	Supply input	Ground

3.3 SIGNAL DESCRIPTION

Signal name: GND	Pin number(s): 15, 20-26, 28, 30, 33-41
These pins are used for grounding and to improve the thermal performance. They should be connected to Host board GND net.	
Signal name: GPIO_X	Pin number(s): 2-6
These pins are used as general purpose IO. They can be configured via SW API as input or output ports. IO voltage level is 3.3V. GPIOs have source current capability of 3mA and sink current capability of 6mA.	
Signal name: ERASE	Pin number(s): 7
This pin is used for production testing purposes only. Should not be connected.	
Signal name: RX	Pin number(s): 8

This pin is used for module UART input signal. Logic level is 3.3V. If UART is used for communication the pin should be connected to the Host MCU serial TX port.	
Signal name: TX	Pin number(s): 9
This pin is used for module UART output signal. Logic level is 3.3V. If UART is used for communication the pin should be connected to the Host MCU serial RX port.	
Signal name: USB_DN	Pin number(s): 10
This pin is used as USB_D- device port. It is advised to use external ESD protection component if connected to user accessible USB connector.	
Signal name: USB_DP	Pin number(s): 11
This pin is used as USB_D+ device port. It is advised to use external ESD protection component if connected to user accessible USB connector.	
Signal name: USB_DET	Pin number(s): 12
This pin is only used for USB connection detection. It is advised to use external ESD protection component if connected to user accessible USB connector. Current is not drawn from this input pin.	
Signal name: VCC_3V3_OUT	Pin number(s): 13
This pin is connected to internal power regulator output. The pin is used for production testing and it should not be used.	
Signal name: MODULE_EN	Pin number(s): 14
Driving this pin to high will enable the NUR-05WL2 module. It is internally connected to onboard voltage regulator's enable input. The trigger level is 1.2V and the reader module will wake up in 50ms. If the external power switch is used to toggle ON and OFF, this pin can be connected directly to VCC_3V6_IN.	
Signal name: NC	Pin number(s): 16, 31, 32
These pins are internally not connected.	
Signal name: VCC_3V6_IN	Pin number(s): 17
This pin is used for power supply input for NUR-05W module. It is recommended to use 200µF (low ESR) 100nF and 100pF capacitor near the VCC_3V6_IN input pin to maintain stable operating voltage for the reader module.	
Signal name: RFU	Pin number(s): 1, 18, 19
These pins are reserved for future use. Do not connect these pins.	
Signal name: GND/RF_DIF	Pin number(s): 29
This pin is internally connected to GND. It is reserved for future use as secondary RF output.	

4 OEM DESIGN CONSIDERATIONS

4.1 RF OUTPUT AND ANTENNA REQUIREMENTS

The RF output / input impedance is 50Ω so the trace leaving from the RF_OUT pin shall be kept in that same impedance level to avoid reflections and mismatch of the RF signal. To provide an appropriate impedance match place the matching components close to RF_OUT pin. Below there is the circuit diagram that shall be utilized in the fine-tuning of the impedance match and in the additional filtering.

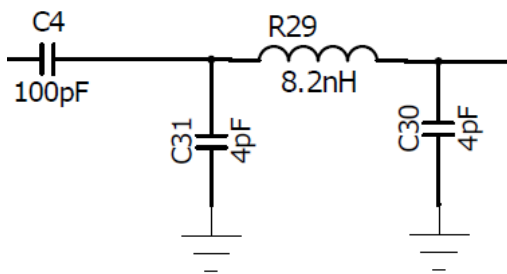

From the RFID reader module's point of view it is important that the used antenna has a low VSWR value. The VSWR shall be better than 1.5:1 in order to avoid decrease in the sensitivity performance of the receiver because of the TX power reflecting back from the antenna. In the NUR-05WL2 module, there is also an automatic leakage cancellation system that decreases the effect of the reflected signal, and it also improves the isolation of the RX signal from the TX signal. The automatic leakage cancellation can be triggered using SW API command. For further information on the leakage cancellation see the section 5.3.

4.2 POWER SUPPLY

The NUR-05WL2 has internal linear power regulators for getting better power supply noise rejection. However it is still important to supply low noise and stable power to the NUR-05WL2 module. The voltage ripple should be kept under 200mVpp and it is recommended to add a minimum of 200 μ F low ESR, 100nF and 100pF capacitors next to the VCC_3V6_IN pin.

VCC_3V3_OUT is internal regulator output and it is used for production testing purposes. This pin should not be used to power external circuits.

4.3 USB DEVICE PORT

USB_DP, USB_DN and USB_DET pins are used to provide 2.0 compliant USB device port. It must be remembered that only one communication method can be used to communicate with the NUR-05WL2 module at the time. Connecting the USB will automatically prevent communication via serial port. It is advised to use external ESD protection component if connected to user accessible USB connector. Below is the typical schematics used with NUR-05WL2 module.

Typical schematics for USB connection with ESD protection.

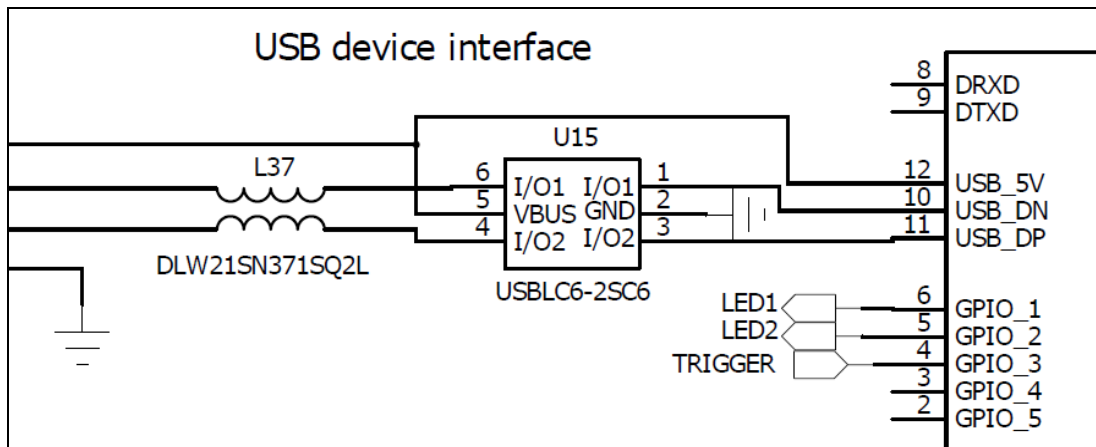

Used components.

Ref	Description	Manufacturer	Part code
U15	ESD protection	ST Microelectronics	USBLC6-2SC6
L37	Common mode choke	Murata	DLW21SN371SQ2L

5 RF PARAMETERS

5.1 TX LEVEL

The maximum output power is +27dBm (500mW). The power can be adjusted by 1dB steps. In total there are 19 steps meaning the minimum output power value is +8dBm that equals to 6mW of power. When using higher output power levels the antennas VSWR value becomes more and more important factor. High output power combined together with antenna with poor VSWR leads to a situation where significant portion of the power is reflected back to the receiver.

TX level	Power: dBm / mW	TX level	Power: dBm / mW
0	27 / 500	10	17 / 50
1	26 / 398	11	16 / 40
2	25 / 316	12	15 / 32
3	24 / 251	13	14 / 25
4	23 / 200	14	13 / 20
5	22 / 158	15	12 / 16
6	21 / 126	16	11 / 13
7	20 / 100	17	10 / 10
8	19 / 79	18	9 / 8
9	18 / 63	19	8 / 6

5.2 RECEIVER SENSITIVITY

The maximum LBT sensitivity is of -80dBm. The receiver can handle +5dBm of power reflecting back to RF_OUT pin without having a big impact on the performance. Tolerance to reflecting signal can be significantly increased using NUR-05WL2 leakage cancellation functionality. The receiver architecture uses direct conversion and it has an integrated AGC (automatic gain controller).

5.3 LEAKAGE CANCELLATION

The directional coupler of the internal leakage cancellation circuitry separates transmitted and received signals. Tuning the directional coupler increases the isolation between TX and RX signals. You may tune the directional coupler using software; there is an API function of its own for that purpose. Notice that the

tuning does not match the RF_OUT with an antenna so the good VSWR (return loss) of the antenna is an essential factor of the good performance of the system.

5.4 MODULATION

It is possible to use ASK (amplitude shift keying) or PR-ASK (phase reversed amplitude shift keying) modulation. Tags that are compliant with ISO18000-6C (EPC C1G2) must support both of these modulations. The PR-ASK modulation can transfer energy more efficiently to the tag because RF envelope is high more than it is using ASK modulation. By default the modulation is set to PR-ASK.

5.5 LINK FREQUENCY

The link frequency affects the frequency offset of tags reply in respect to reader's carrier wave. For example when used link frequency is 256 kHz, tag will reply at the frequency of reader transmission frequency \pm 256 kHz. The selectable parameters are 160 kHz, 256 kHz and 320 kHz. Tags that are compliant with ISO18000-6C (EPC C1G2) must support all these parameters. The link frequency also affects tag to reader data rate which is calculated by formula below:

Tag to reader data rate = (Link frequency / Miller coding)

By default the link frequency is set to 256 kHz. 256 kHz or 320 kHz settings must be used when operating in DRM mode. It must be remembered that changing these parameters may cause reader to violate region or country specific radio regulations. Following is a guideline for how to choice right setting. If channel bandwidth is 200 kHz than 256 kHz or lower link frequency should be used (for example in EU). When operating in a region where 500 kHz channel bandwidth is available also 320 kHz link frequency can be used.

Spectral separation caused by 256 kHz link frequency and Miller sub-carrier encoding.

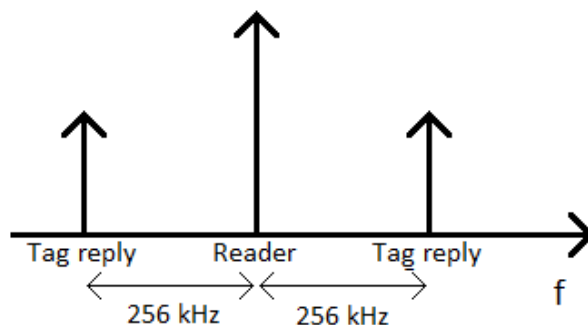

5.6 RX ENCODING (MILLER ENCODING)

Like stated above the Miller sub-carrier encoding scheme affects also tag to reader data rate. In practice the Miller encoding value affects the number of clock cycles that tag uses to modulate one symbol. So when using higher Miller encoding schemes tag to reader data rate will be slower but at the same time it is more robust to interferences. Also tags response spectrum is more concentrated around the link frequency when using higher Miller schemes. This allows the receiver to use narrower channel filters. Selectable values are M2, M4, M8 or FM0.

Receiver filters are optimized for M4 and M8 encoding schemes. When operating on DRM mode values 4 or 8 should be used to optimize the performance. By default Miller 4 is used. In addition to miller schemes also FM0 encoding is supported. In this case link frequency directly determines the tag to reader data rate.

Table describing different data rates.

Link frequency (kHz)	RX encoding	Tag to reader data rate (kbps)
160	FM0	160
160	M2	80
160	M4	40
160	M8	20
256	FM0	256
256	M2	128
256	M4	64
256	M8	32
320	FM0	320
320	M2	160
320	M4	80
320	M8	40

5.7 REGION

The NUR-05WL2 has predefined region settings defining frequency and channel sets for operating under different radio regulations. Globally the regulations vary depending on the country or part of the world. The below table shows the available options for the region and the respective frequency band they use. Note that the antenna also needs to be working on that same frequency.

Table showing pre-programmed countries / regions.

Number	Country / region	Frequency / channel BW
0	ETSI / Europe	865.6 – 867.6 MHz / 200kHz
1	FCC / North-America	902 – 928 MHz / 500 kHz

2	People's Republic of China	920.5 – 924.5 MHz / 250 kHz
3	Malaysia	919 – 923 MHz / 500 kHz
4	Brazil	915 – 928 MHz / 500 kHz
5	Australia	920 – 926 MHz / 500 kHz
6	New Zealand	921.5 – 928 MHz / 500 kHz
7	Japan 250mW LBT	916.8 – 923.4 MHz / 200 kHz
8	Japan	916.8 – 920.4 MHz / 200 kHz
9	Custom	840 – 960 MHz

If you want to use custom frequencies or hop tables you need to feed parameter described below.

Table describing custom hop table parameters.

Parameter	Value	Description
Frequency entry	840 000 – 960 000 [kHz]	Defines the center frequency of the first transmit channel.
Channel count	1 - 100	Defines the number of transmit channels
Channel spacing	25 * n [kHz]	Defines the frequency between transmit channels.
Channel time	minimum 100 ms	Defines the time that reading is ON at the same channel
Wait time	maximum 1000 ms	Defines the time that transmitter is silent between frequency hops
Tari	1=12.5us 2=25us	Defines the Tari value
LF	160 000, 256 000 or 320 000	Defines the maximum link frequency that is used

6 READING PARAMETERS

6.1 Q-VALUE

The Q-value defines the amount of open response slots that tags can use per one inventory round. Number of slots can be calculated by formula 2^Q . It is advised to use twice as much slots compared to amount of tags that you have in your readers reading field simultaneously. Selectable values are 0 – 15 and value 0 means automatic Q-value adjustment. When Q=0 is used reader will automatically increase the Q-value when lots of collisions are noticed and decreased the value when there are only few collisions. By default the Q-value is set to 0.

Table indicating the relation between the Q-value and the number of open slots per round.

Q-value	slots	Q-value	slots
0	automatic	8	256
1	2	9	512
2	4	10	1024
3	8	11	2048
4	16	12	4096
5	32	13	8192
6	64	14	16384
7	128	15	32768

6.2 SESSION

There are four session options which you can use when initializing inventory round. Every session has two target states A and B. By default Gen2 tags are at state A if tag has not been read recently. When tag is read it flips to state B and doesn't reply to readers query. The table below describes the persistence of tag's state machine when using different session values. For example when using session 0 the tag will come back to state A immediately when tag power is lost. Usually tag loses the power when reader stops the inventory round or changes the channel. Persistence when tag power is ON is not defined by the ISO18000-6C when using session settings S0, S2 and S3. With session 1 the tag will keep it state over 500ms but less than 5s. With session values 2 and 3 tags will keep it states over 2s when tag power is lost. Time can vary depending what tag IC is used.

Table indicating persistence characteristics of gen2 tags.

Flag	Persistence: tag power ON	Persistence: tag power OFF
S0	indefinite	none
S1	500ms < t < 5s	500ms < t < 5s
S2	indefinite	t > 2s
S3	indefinite	t > 2s

By changing the target setting from A target to B target reader is able to read also tags that has flipped its state to B state. This would happen if tags would have been read recently using Session 1 2 or 3. NUR-05WL2 module also supports dual target mode. In that mode reader will change the target mode between inventory rounds. By default target mode A is used.

6.3 ROUNDS

The rounds setting defines how many query rounds is done inside one inventory round. After every inventory round the reader will send data to the Host. Selectable values are 0 – 10. Zero meaning automatic rounds adjustment. The automatic adjustment decides after every query round whether another round is necessary based on the number of data collisions. By default rounds setting is set to 0. This setting can help the reader to find all the tags that are in the readers reading field when using session 0. Because tags that are found in query round 1 doesn't replay in the following query rounds. When using session 1/2/3 this does not make any significant difference because tags that are read are quiet anyway.

Table describing relation between inventory round and query round.

Inventory round				
Round 1	Round 2	round 3	...	Round 10

6.4 SELECTING THE RIGHT READING PARAMETERS

One approach is to test how many tags are in the readers reading field simultaneously. Keep the reader still at the position that is as close to real reading environment as possible and see how many tags are found. Based on that amount choose your open slot number to be 1.5 – 2 times larger (refer to the section 6.1). If reader will face many different tag populations auto-Q setting will be a good choice.

Besides Q-value one important parameter is session. In general it could be stated that if the size of tag population is measured in thousands rather than in hundreds it is wise to use sessions 2 or 3. Because then every tag will be read only once and that makes large tag population much faster and easier to read. When using session 2 or 3 it is advised to use Miller 8 encoding scheme to avoid data transfer errors as much as possible. Rounds 1 setting is also advised to be used with session 1 or 2 or 3. With session 0 it might be useful to use higher rounds value than 1 to be able to find all the individual tags. By default automatic (0) rounds setting is used.

Other settings like modulation, link frequency and RX-encoding has a minor impact to the reading speed of the reader. When operating in optimal environment following will apply:

RX encoding: FM0 is fastest but quite sensitive to interferences / M8 slowest but very robust

Modulation: No effect to speed but PR-ASK has better range with some tags

Link frequency: 320 kHz is the fastest / 160 kHz is the slowest

Guideline settings to be used with different tag populations.

Settings	Tag population	Simultaneously in the field
Session 0, auto Q, auto Rounds	1 – 100	1 – 100
Session 1, auto Q, Rounds 1	100 – 1 000	under 500
Session 2/3, auto Q, Rounds 1	100 – 1 000	over 500
Session 2/3, auto Q, Rounds 1	over 1 000	over 500

7 GPIO CONFIGURATIONS

NUR-05WL2 has 5 programmable GPIOs. All of them can be used as an input or output. They can be also configured to have different predefined functions.

7.1 INPUT / OUTPUT

All GPIOs can be configured via SW API to be inputs or outputs. IO voltage level is 3.3V and maximum source current is 3mA and sink current 6mA. When configured as input SW API can check what the state (high / low) of the GPIO pin is. When GPIO is configured as an output the SW API can drive the GPIO pin to high or low.

7.2 PREDEFINED FUNCTIONS

The below table describes how the NUR-05W module GPIOs can be configured.

I/O	Function	Action	Trigger
Output	-	-	-
Output	RFON	-	-
Output	RFIDREAD	-	-
Output	Beeper	-	-
Output	Antenna control 1	-	-
Output	Antenna control 2	-	-
Input	-	-	-
Input	-	Notify	rising/falling/both
Input	-	Scantag	rising/falling/both
Input	-	Inventory	rising/falling/both

RFON (GPIO type: OUTPUT)

When GPIO is configured as “RFON” it drives high state always when power amplifier is turned on. This function can be used for example driving LED indicator.

RFIDREAD (GPIO type: OUTPUT)

When “RFIDREAD” function is selected will GPIO pin drive high for a short period of time after a timeout has surpassed after last successful tag reading. The timeout can be defined as a parameter for the function. If no tags were successfully read and the timeout was surpassed the pin will drive high three times. This

function can be used for example driving a LED indicator. Note that this function requires a “scan tag” or “inventory” trigger from another GPIO pin set as an input.

Beeper (GPIO type: OUTPUT)

When “beeper” function is used will GPIO pin drive high for a short period of time after a timeout has surpassed after last successful tag reading. The timeout can be defined as a parameter for the function. If no tags were successfully read and the timeout was surpassed the pin will drive high three times. This function can be used for example driving a beeper. Note that this function requires a “scan tag” or “inventory” trigger from another GPIO pin set as an input. GPIO is high also when sending a beep command (13) over the SW API.

Inventory (GPIO type: INPUT)

When “inventory” function is selected will reader start reading when it is triggered by selected GPIO. Triggering can be configured to be from falling / rising / both edges. Reader will read as long as it finds new tags. Time interval between end of reading and last found tag can be configured.

Scantag (GPIO type: INPUT)

When GPIO is configured as “scan tag” reader will perform just one read. Triggering can be configured to be from falling / rising / both edges

Notify (GPIO type: INPUT)

When GPIO is configured as “notify” will reader send notification to Host application when triggered by selected GPIO. Triggering can be configured to be from falling / rising / both edges

Antenna control 1 (GPIO type: OUTPUT)

When GPIO is configured as “antenna control 1” it can be used for controlling external multiplexer on the Host board to switch between two antennas. Via the SW API it’s possible to select which antennas are enabled and used or let the module automatically switch between them.

Case (selected antenna)	antenna control 1
0 (antenna 1)	low
1 (antenna 2)	high

Antenna control 1 & 2 (GPIO type: OUTPUT)

If you want to connect up to 4 antennas and multiplex those using NUR-05WL2 module you need to configure 2 GPIOs to control the antenna switch. In this case you define one GPIO to be “antenna control 1” and second one to be “antenna control 2”. Via the SW API it’s possible to select which of the connected antennas are enabled and used or let the module automatically switch between them.

Case (selected antenna)	antenna control 1	antenna control 2
0 (antenna 1)	low	low
1 (antenna 2)	high	low
2 (antenna 3)	low	high
3 (antenna 4)	high	high

8 DIAGNOSTIC FUNCTIONS

8.1 REFLECTED POWER MEASUREMENTS

This measurement can be used to check what is the matching of the antenna(s) and feed line(s). When this function is triggered will NUR-05WL2 module put carrier wave ON at full power and then measure the absolute power level that is coming to receiver port. Attenuation in the RX-line is 11 dB and full output power is 27 dBm. Based on these two values you can determine antennas return loss (S11) value using formula below:

Antennas return loss = Power to antenna – (RX-line attenuation + reflected power meas.)

Antennas return loss = 27 – 11 – (reflected power meas.)

When leakage cancelation is used these calculations are no longer absolute return loss values because cancellation circuitry eliminates some amount of the signal reflecting back from the antenna. In this case this value is the absolute power value that is leaking into the receiver due to imperfect coupler isolation or antenna mismatch.

8.2 CHANNEL SCANNER

This function can be used to monitor the interferences in the current frequency band. It is also useful if you want to check if some fixed channel is in use. When you trigger this function NUR-05WL2 will scan all the channels in current region and return the RSSI-value of each channel. Returned values are absolute power levels in receiver. Loss between RF_OUT pin and receiver is 11 dB so actual values are about 11dB higher.

8.3 RECEIVED SIGNAL STRENGTH (RSSI)

When reading a tag NUR-05WL2 module also returns received signal strength indication values if wanted. Two values are returned per one tag. One is the absolute power level (dBm) and second is the scaled power level value of the tags backscatter signal. NUR-05WL2 module automatically adjusts receiver according to output power levels. Causing that maximum and minimum absolute RSSI power levels will vary depending from the used output power levels. That is why scaled RSSI value is also available. Scale is 0 – 100.

9 DIMENSIONS

9.1 MECHANICAL DIMENSIONS

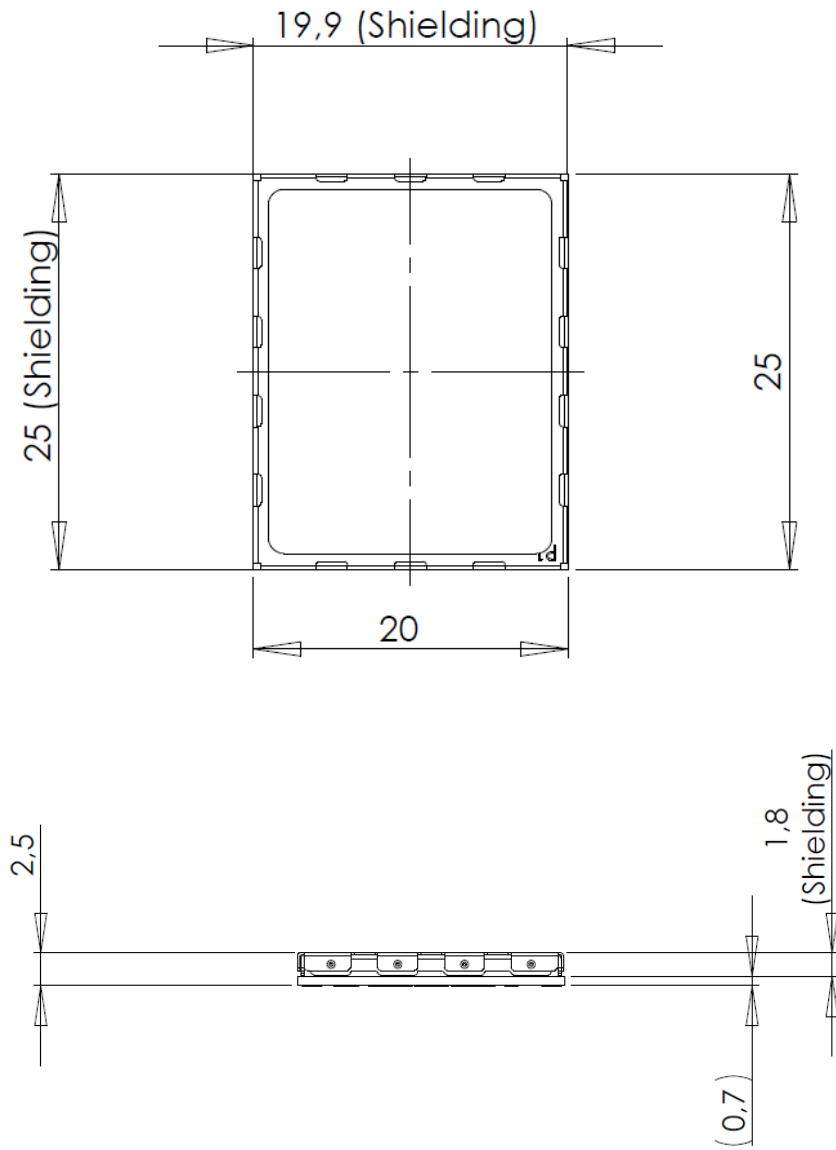

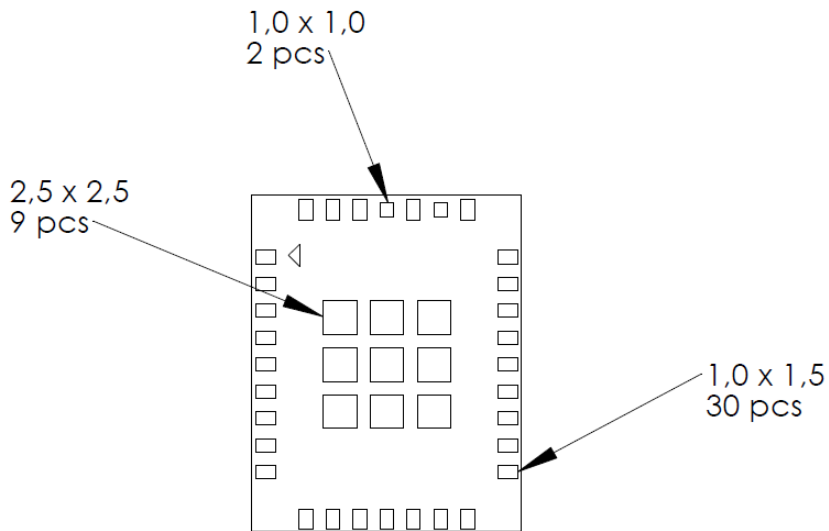
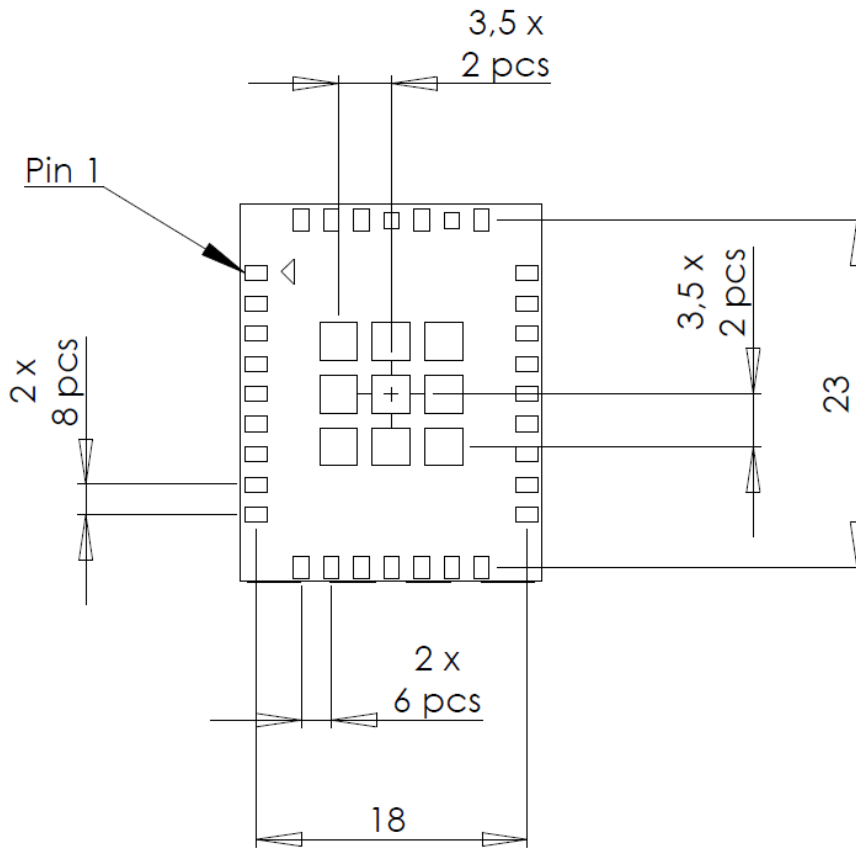

9.2 LAND PATTERN

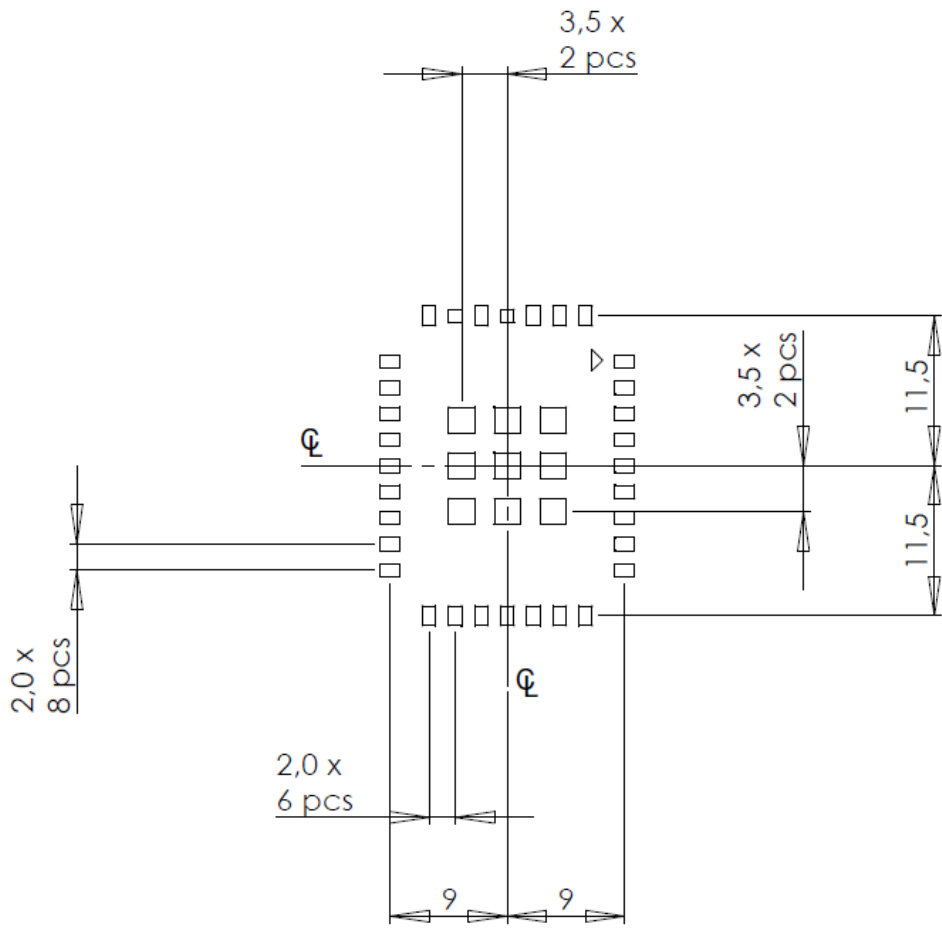

General pad detail

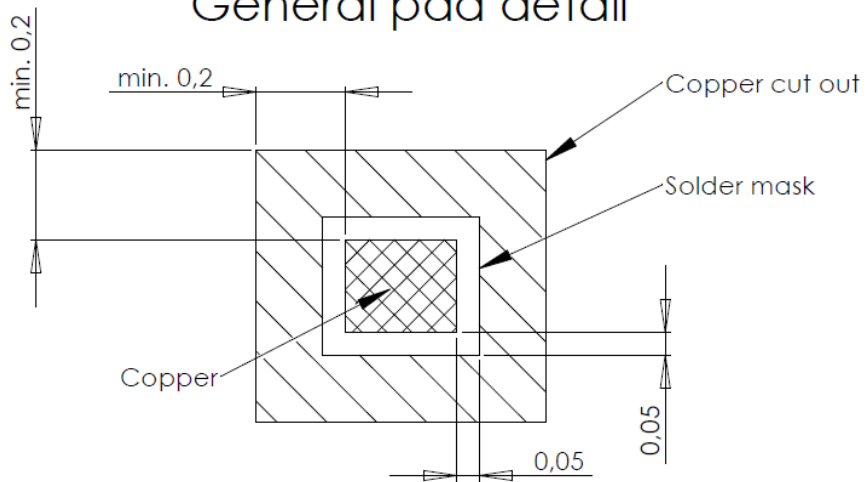

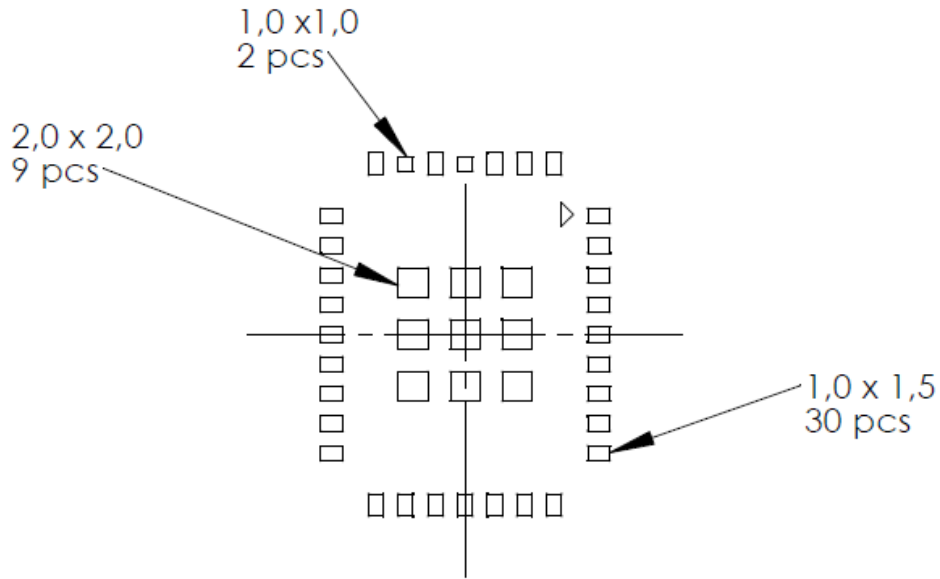

9.3 PASTE STENCIL

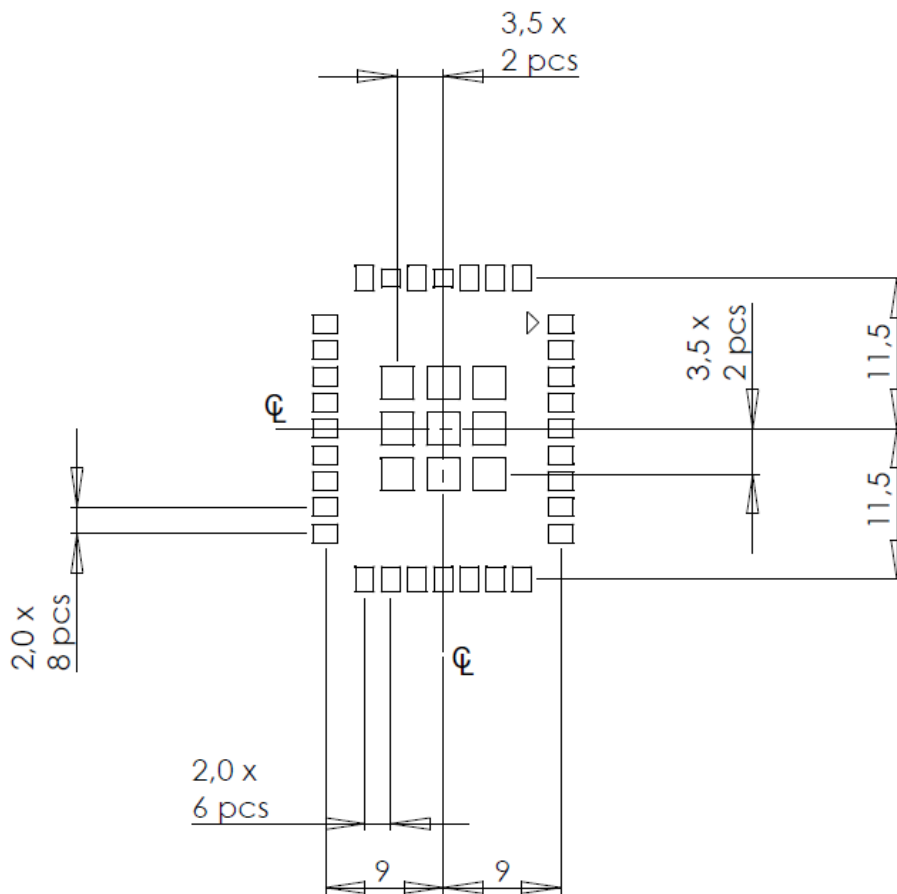

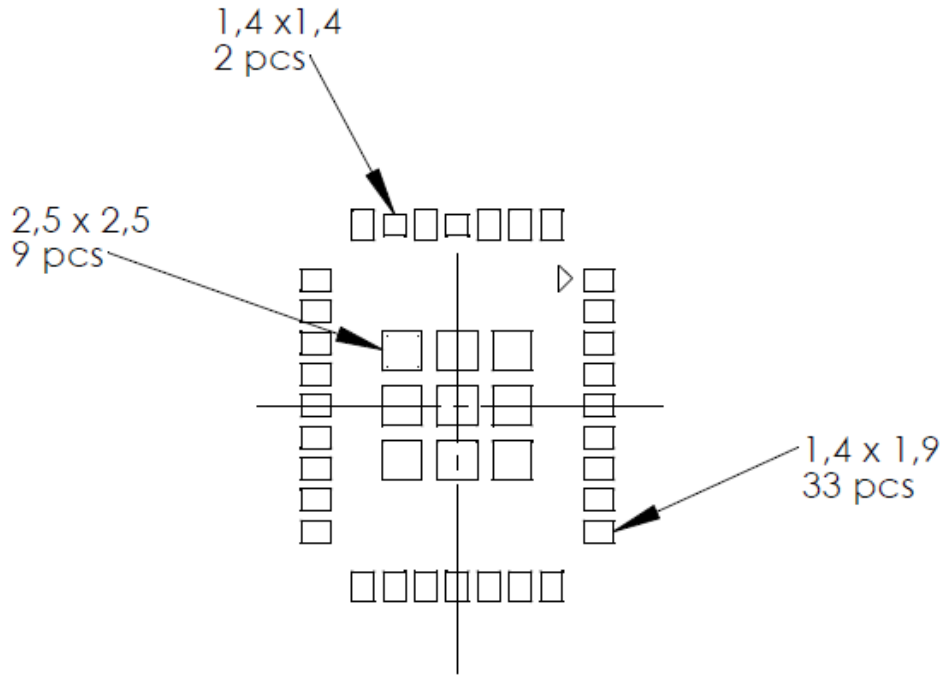

9.4 PACKING TRAY DIMENSIONS

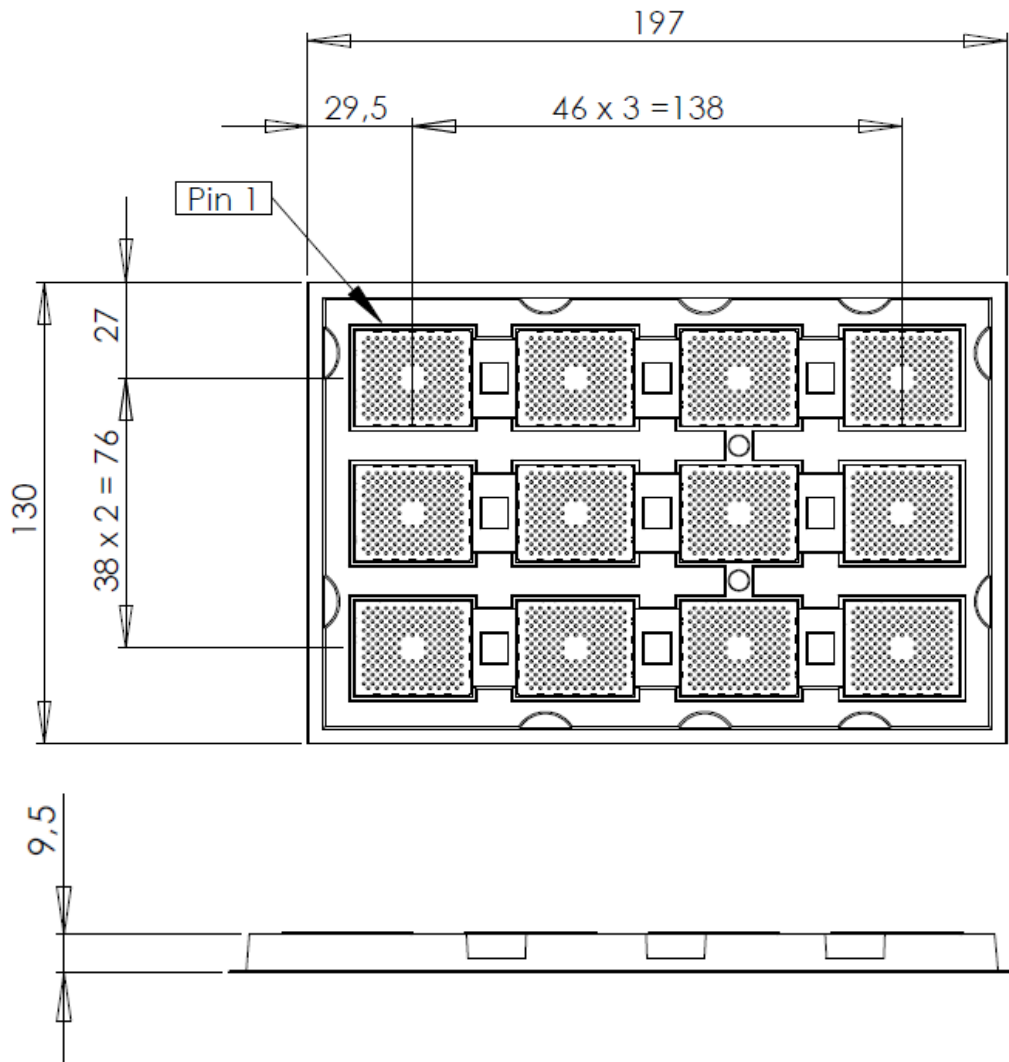

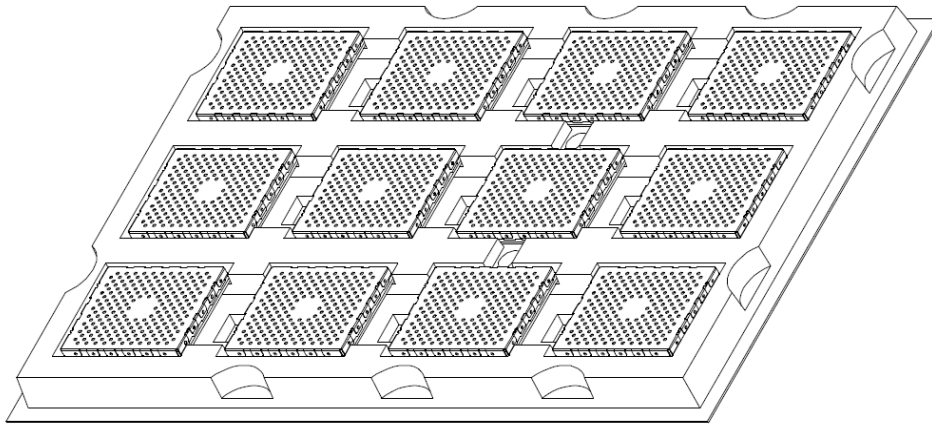

All measures are in mm.

10 SMT ASSEMBLY PROCESS AND THERMAL PROCESSING

NUR-05WL2 module contains single sided assembly of SMT components reflow-soldered on multilayer HDI (high density interconnections) glass-fiber re-enforced epoxy printed board. The bottom side terminations are ENIG (NiP/Au) plated. Soldering alloy used for attaching module components is eutectic SnAgCu. Module internal components soldering has been optimized for minimal thermal stress.

NUR-05WL2 modules shall be delivered in a special tray packing to protect modules against mechanical, ESD and moisture related stresses. Due to high density interconnections technology, module total water content have to be below 0.1%-w prior to any thermal processing above water boiling point.

The board assembly process of NUR module on motherboard will introduce re-flow of module components. Thus, to avoid degradation of solder joint interfaces, the module has to be stored and soldered according to the guidelines given below.

10.1 STORAGE CONDITIONS

Long-term storage

Store modules in unopened vacuum packs in a dry cabinet under following environmental conditions

Temperature	+15...+27°C (optimal)
Temperature gradient	max. 2°C/hour
Relative humidity	<15% within specified temperature range

Opened and broken packages have to be re-sealed. If open time (floor life out of pack) has been exceeded, or moisture content detected, modules have to be baked prior to re-sealing vacuum pack.

Short-term storage (typically same as production environment)

Temperature	+20...+27°C
Temperature gradient	max. 2°C/hour
Relative humidity	<15% within specified temperature range

Modules may be stored in a dry cabinet without protective packing according to **IPC/JEDEC J-STD-033B.1, table 7-1.**

MSL level and open time

MSL level	5
Open time (floor life out of the bag)	48h

10.2 SOLDERING PROCESS

Boundary conditions

Acceptable soldering methods	Convection reflow in air or nitrogen atmosphere Condensation reflow soldering (vapor phase)
Recommended stencil thickness	125um ±10um
Pad design on motherboard	See recommended pad pattern
Stencil openings	See recommended stencil pattern
Recommended solder alloy	SnAg3.8±0.2Cu0.7±0.2 Note! If using under-eutectic solder alloys, such as SAC305, it may be necessary to increase reflow peak temperature by 5-10°C, due to higher mp. and lower fluidity of non-eutectic SnAgCu alloys. This will increase thermal stress to module and motherboard greatly.
Convection reflow oven heater configuration	Double sided heating required in reflow, recommended in preheating zones.
Maximum absorbed moisture content prior to thermal processing	0.1%-w (Test method IPC-TM-650, 2.6.28) Moisture content and/or moisture absorption rate, Printed Board
Recommended moisture reduction condition	+60°C/12h vacuum pack removed during drying, re-seal after drying, unless modules will be used within allowed open time after drying
Moisture and solvent contamination	No moisture or solvent contamination allowed in solder paste or on solderable surfaces

Recommended reflow conditions

Preheating phase	-max. duration 180s -end temperature 190-200°C
------------------	---

	-delta T on assembly max. 10°C at end of preheating
Soldering phase	-total duration 190s -max. time above 217°C (mp.) 30s -Tpeak max. 235°C, measured at module bottom -Tpeak max. 225°C, measured at motherboard surface, under module
Cooling	Two-stage, double sided cooling recommended 1 st stage: 2-5°C/s cooling until melting point 2 nd stage: 1-3°C/s after melting point

11 REGULATORY AGENCIES INFORMATION

When OEM prefers to leverage Nordic ID's grants and certifications of the NUR-05WL2 UHF RFID module, the host device documentation shall include regulatory compliance information on the NUR-05WL2 module. Corresponding to the applicable regulatory agencies the following sections outline regulatory compliance information needed in the user documentation and external labels for the host devices into which the NUR-05WL2 is integrated.

When leveraging Nordic ID's grants and certifications, antenna shall be taken into account in view of the fact that the NUR-05WL2 module has met the essential regulatory requirements with the antennas listed in the context of particular regulatory compliance information (Approved Antennas). Using the antenna that is an approved one, OEM integrator may demonstrate with less effort that the device with the integrated NUR-05WL2 module is in compliance with the requirements.

11.1 EUROPEAN UNION AND EFTA COUNTRIES

USER'S GUIDE REQUIREMENTS

This apparatus is in compliance with the essential requirements of the R&TTE Directive 1999/5/EC. In order to prove presumption of conformity with the essential requirements of the R&TTE Directive 1999/5/EC the following requirements and test methods have been applied to the apparatus:

- article 3.2: ETSI EN 302 208 v1.3.1
Radio spectrum matters for Radio Frequency Identification (RFID) equipment operating in the band 865 MHz to 868 MHz with power levels up to 2W
- article 3.1b: ETSI EN 301 489-1 v1.9.1
Common ElectroMagnetic Compatibility (EMC) requirements
- article 3.1b: ETSI EN 301 489-3 v1.4.1
Specific ElectroMagnetic Compatibility (EMC) conditions for Short-Range Devices (SRD) operating on frequencies between 9 kHz and 40 GHz
- article 3.1a: EN 60950-1:2005
General requirements for Safety of Information Technology Equipment

This apparatus is in compliance with EU Directive 2003/95/EC, Reduction of Hazardous Substances (RoHS).

Česky**[Czech]**

[name of manufacture] tímto prohlašuje, že tento [type of apparatus] je ve shodě se základními požadavky a dalšími příslušnými ustanoveními směrnice 1999/5/ES.

Dansk**[Danish]**

Undertegnede [name of manufacture] erklærer herved, at følgende udstyr [type of apparatus] overholder de væsentlige krav og øvrige relevante krav i direktiv 1999/5/EF.

Deutsch**[German]**

Hiermit erklärt [name of manufacture], dass sich das Gerät [type of apparatus] in Übereinstimmung mit den grundlegenden Anforderungen und den übrigen einschlägigen Bestimmungen der Richtlinie 1999/5/EG befindet.

Eesti**[Estonian]**

Käesolevaga kinnitab [name of manufacture] seadme [type of apparatus] vastavust direktiivi 1999/5/EÜ põhinõuetele ja nimetatud direktiivist tulenevatele teistele asjakohastele sätetele.

English

Hereby, [name of manufacture], declares that this [type of apparatus] is in compliance with the essential requirements and other relevant provisions of Directive 1999/5/EC.

Español**[Spanish]**

Por medio de la presente [name of manufacture] declara que el [type of apparatus] cumple con los requisitos esenciales y cualesquiera otras disposiciones aplicables o exigibles de la Directiva 1999/5/CE.

Ελληνική**[Greek]**

ΜΕ ΤΗΝ ΠΑΡΟΥΣΑ [name of manufacture] ΔΗΛΩΝΕΙ ΟΤΙ [type of apparatus] ΣΥΜΜΟΡΦΩΝΕΤΑΙ ΠΡΟΣ ΤΙΣ ΟΥΣΙΩΔΕΙΣ ΑΠΑΙΤΗΣΕΙΣ ΚΑΙ ΤΙΣ ΛΟΙΠΕΣ ΣΧΕΤΙΚΕΣ ΔΙΑΤΑΞΕΙΣ ΤΗΣ ΟΔΗΓΙΑΣ 1999/5/ΕΚ.

Français**[French]**

Par la présente [name of manufacture] déclare que l'appareil [type of apparatus] est conforme aux exigences essentielles et aux autres dispositions pertinentes de la directive 1999/5/CE.

Italiano**[Italian]**

Con la presente [name of manufacture] dichiara che questo [type of apparatus] è conforme ai requisiti essenziali ed alle altre disposizioni pertinenti stabilite dalla direttiva 1999/5/CE.

Latviski**[Latvian]**

Ar šo [name of manufacture] deklarē, ka [type of apparatus] atbilst Direktīvas 1999/5/EK būtiskajām prasībām un citiem ar to saistītajiem noteikumiem.

Lietuvių**[Lithuanian]**

Šiuo [name of manufacture] deklaruoja, kad šis [type of apparatus] atitinka esminius reikalavimus ir kitas 1999/5/EB Direktyvos nuostatas.

Nederlands**[Dutch]**

Hierbij verklaart [name of manufacture] dat het toestel [type of apparatus] in overeenstemming is met de essentiële eisen en de andere relevante bepalingen van richtlijn 1999/5/EG.

Malti**[Maltese]**

Hawnhekk, [name of manufacture], jiddikjara li dan [type of apparatus] jikkonforma mal-ħtigijiet essenzjali u ma provvedimenti oħrajn relevanti li hemm fid-Dirrettiva 1999/5/EC.

Magyar**[Hungarian]**

Alulírott, [name of manufacture] nyilatkozom, hogy a [type of apparatus] megfelel a vonatkozó alapvető követelményeknek és az 1999/5/EC irányelv egyéb előírásainak.

Polski**[Polish]**

Niniejszym [name of manufacture] oświadcza, że [type of apparatus] jest zgodny z zasadniczymi wymogami oraz pozostałymi stosownymi postanowieniami Dyrektywy 1999/5/EC.

Português**[Portuguese]**

[name of manufacture] declara que este [type of apparatus] está conforme com os requisitos essenciais e outras disposições da Directiva 1999/5/CE.

Slovensko**[Slovenian]**

[name of manufacture] izjavlja, da je ta [type of apparatus] v skladu z bistvenimi zahtevami in ostalimi relevantnimi določili direktive 1999/5/ES.

Slovensky**[Slovak]**

[name of manufacture] týmto vyhlasuje, že [type of apparatus] spĺňa základné požiadavky a všetky príslušné ustanovenia Smernice 1999/5/ES.

Suomi**[Finnish]**

[name of manufacture] vakuuttaa täten että [type of apparatus] tyyppinen laite on direktiivin 1999/5/EY oleellisten vaatimusten ja sitä koskevien direktiivin muiden ehtojen mukainen.

Svenska**[Swedish]**

Härmed intygar [name of manufacture] att denna [type of apparatus] står i överensstämmelse med de väsentliga egenskapskrav och övriga relevanta bestämmelser som framgår av direktiv 1999/5/EG.

LABELING REQUIREMENTS

The 'CE' marking must be in a visible area on the OEM product.

APPROVED ANTENNAS

Maximum allowed ERP power is 33dBm. NUR-05WL2 has output power of 27dBm. Meaning that 8dBi is the maximum allowed antenna gain.

Formula how to calculate maximum allowed antenna gain:

$$27 \text{ dBm} - 2.15 (\text{dipole gain}) + [\text{antenna gain dBi}] - [\text{cable attenuation dB}] < 33 \text{ dBm}$$

Beamwidth restrictions:

For transmissions ≤ 500 mW e.r.p. there shall be no restriction on beamwidth.

For transmissions of > 500 mW e.r.p. to $\leq 1\,000$ mW e.r.p. beamwidths shall be $\leq 180^\circ$

For transmissions of $> 1\,000$ mW e.r.p. to $2\,000$ mW e.r.p. beamwidths shall be $\leq 90^\circ$

11.2 FCC

This equipment has been tested and found to comply with the limits for a Class B digital device, pursuant to Part 15 of the FCC Rules. These limits are designed to provide reasonable protection against harmful interference in a residential installation. This equipment generates uses and can radiate radio frequency energy and, if not installed and used in accordance with the instructions, may cause harmful interference to radio communications. However, there is no guarantee that interference will not occur in a particular installation. If this equipment does cause harmful interference to radio or television reception, which can be determined by turning the equipment off and on, the user is encouraged to try to correct the interference by one of the following measures:

- Reorient or relocate the receiving antenna.
- Increase the separation between the equipment and receiver.
- Connect the equipment into an outlet on a circuit different from that to which the receiver is connected.
- Consult the dealer or an experienced radio/TV technician for help.

This device complies with Part 15 of the FCC Rules. Operation is subject to the following two conditions: (1) This device may not cause harmful interference, and (2) this device must accept any interference received, including interference that may cause undesired operation.

FCC Caution: Any changes or modifications not expressly approved by the party responsible for compliance could void the user's authority to operate this equipment.

This NUR-05WL2 transmitter module is authorized to be used in other devices only by OEM Integrators under the following conditions:

1. The antenna(s) must be installed such that a minimum separation distance of 20cm is maintained between the radiator (antenna) & user 's/nearby people ' s body at all times.
2. The transmitter module must not be co-located with any other transmitter, except with those that are within the limits shown in the NUR-05WL2 filing.
3. The transmitter module can only be used with a host antenna circuit trace layout design in strict compliance with the OEM instructions provided.

When the conditions above are met, typically no further transmitter testing is required. However, the OEM integrator is still responsible for testing their end-product for any additional compliance requirements required with this module installed (for example, digital device emissions, PC peripheral requirements, etc.).

The antenna used with the NUR-05WL2 transmitter module can have a gain of 8 dBi at the maximum. Higher gain antennas may be used if cable loss compensates the exceeded antenna gain. For example 2dB antenna cable loss reduces EIRP so that 10dBi antenna may be used.

Note

In the event that these conditions can't be met (for certain configurations or co-location with another transmitter), then the FCC authorization is no longer considered valid and the FCC ID can't be used on the final product. In these circumstances, the OEM integrator will be responsible for reevaluating the end product (including the transmitter) and obtaining a separate FCC authorization.

The OEM integrator has to be aware not to provide information to the end user regarding how to install or remove this RF module in the user manual of the end product.

For the User's Guide the required FCC statements outlined in the User's Guide Requirements section must be in a prominent location.

USER'S GUIDE REQUIREMENTS

"To comply with FCC's RF radiation exposure requirements, the antenna(s) used for this transmitter must be installed such that a minimum separation distance of 20cm is maintained between the radiator (antenna) & user's/nearby people's body at all times and must not be co-located or operating in conjunction with any other antenna or transmitter."

"This device complies with Part 15 of the FCC Rules"

"Any changes or modifications to the transmitting module not expressly approved by Nordic ID Oy could void the user's authority to operate this equipment"

LABELING REQUIREMENTS

The end product must be labeled with the following identification information in a visible area:

"Contains Transmitter Module FCC ID: SCCNUR05WL2"

or

"Contains FCC ID: SCCNUR05WL2"

APPROVED ANTENNAS

Option 1:

Manufacturer:	Nordic ID
Antenna Description:	Circular polarized patch antenna
Frequency range:	902 – 928 MHz
Manufacturer Part Number:	Sampo S0
Gain:	7dBi

Option 2:

Manufacturer:	TBD
Antenna Description:	TBD
Frequency range:	TBD
Manufacturer Product Name:	TBD
Gain:	TBD

Option 3:

Manufacturer:	TBD
Antenna Description:	TBD
Frequency range:	TBD
Manufacturer Product Name:	TBD
Gain:	TBD

11.3 INDUSTRY CANADA

This device complies with Industry Canada licence-exempt RSS standard(s). Operation is subject to the following two conditions: (1) this device may not cause interference, and (2) this device must accept any interference, including interference that may cause undesired operation of the device.

Under Industry Canada regulations, this radio transmitter may only operate using an antenna of a type and maximum (or lesser) gain approved for the transmitter by Industry Canada. To reduce potential radio interference to other users, the antenna type and its gain should be so chosen that the equivalent isotropically radiated power (e.i.r.p.) is not more than that necessary for successful communication.

To leverage the Nordic ID’s IC grant, the device with the integrated NUR-05WL2 module shall be met the following conditions:

1. The antenna used with the NUR-05WL2 module must be installed so that the distance of the antenna from all persons can be maintained at least 20 cm in every situation.
2. The antenna(s) used with the NUR-05WL2 module must not be collocated in conjunction with any other transmitter or its antenna that is capable of transmitting at the same time, except the transmitter-antenna configurations that are within the limits of the NUR-05WL2’s IC grant.
3. The design of an antenna circuit trace layout in a host shall comply with the OEM design instructions provided.

When the conditions above are met, typically no transmitter testing is required, although the OEM integrator shall demonstrate that the end-product is in compliance with the other regulatory requirements.

There is no user’s documentation requirements other than that the required FCC statements outlined in the FCC section are in a prominent place in the user’s guide.

LABELLING REQUIREMENTS FOR THE HOST DEVICE

The end product must be labeled with the following identification information in a visible area:

“Contains IC: 5137A-NUR05WL2”

CERTIFIED ANTENNAS

This radio transmitter 5137A-NUR05WL2 has been approved by Industry Canada to operate with the antenna types listed below with the maximum permissible gain and required antenna impedance for each antenna type indicated. Antenna types not included in this list, having a gain greater than the maximum gain indicated for that type, are strictly prohibited for use with this device.

Option 1:

Manufacturer:	Nordic ID
Antenna Description:	Circular polarized patch antenna
Frequency range:	902 – 928 MHz
Manufacturer Part Number:	Sampo S0
Gain:	7dBi

11.4 INDUSTRIE CANADA

Le présent appareil est conforme aux CNR d'Industrie Canada applicables aux appareils radio exempts de licence. L'exploitation est autorisée aux deux conditions suivantes : (1) l'appareil ne doit pas produire de brouillage, et (2) l'utilisateur de l'appareil doit accepter tout brouillage radioélectrique subi, même si le brouillage est susceptible d'en compromettre le fonctionnement.

Conformément à la réglementation d'Industrie Canada, le présent émetteur radio peut fonctionner avec une antenne d'un type et d'un gain maximal (ou inférieur) approuvé pour l'émetteur par Industrie Canada. Dans le but de réduire les risques de brouillage radioélectrique à l'intention des autres utilisateurs, il faut choisir le type d'antenne et son gain de sorte que la puissance isotrope rayonnée équivalente (p.i.r.e.) ne dépasse pas l'intensité nécessaire à l'établissement d'une communication satisfaisante..

Le module transmetteur NUR-05WL2 est autorisé à être utilisé avec d'autres appareils uniquement par des intégrateurs OEM sous les conditions suivantes:

1. La ou les antenne(s) doivent être installées à une distance de separation minimum de 20cm, celle-ci doit être maintenue entre le radiateur (antenne) et le(s) utilisateur(s)/ ou toute(s) autre(s) personne(s) a tout moment.
2. Le module transmetteur ne doit pas être colocalisé avec d'autre(s) transmetteur(s), sauf si ce(s) dernier(s) répond(ent) avec ceux qui sont dans les limites indiquées dans l'application de NUR-05WL2
3. Le module transmetteur peut être uniquement utilisé avec un schema du design de configuration de la piste du circuit de l'antenne hôte en respectant strictement les instructions OEM fournies.

EXIGENCES APPLICABLES AUX APPAREILS HÔTES

Le produit fini doit disposer d'étiquette mentionnant les information suivantes d'identification sur une surface visible:

“Contains IC: 5137A-NUR05WL2”

TYPES D'ANTENNES ACCEPTABLES

Le présent émetteur radio (IC: 5137A-NUR05WL2) a été approuvé par Industrie Canada pour fonctionner avec les types d'antenne énumérés ci-dessous et ayant un gain admissible maximal et l'impédance requise pour chaque type d'antenne. Les types d'antenne non inclus dans cette liste, ou dont le gain est supérieur au gain maximal indiqué, sont strictement interdits pour l'exploitation de l'émetteur.

Option 1:

Fabricant:	Nordic ID
Déscription de l'antenne:	Circular polarized patch antenna
Portée de la fréquence:	902 – 928 MHz
Numéro de la pièce du fabricant:	Sampo S0
Gain:	7dBi