

NordicTrack[®] **INCLINE X3 Interactive** **TRAINER**

www.nordictrack.com

Model No. NTL15008.0

Serial No. _____

Write the serial number in the space above for reference.

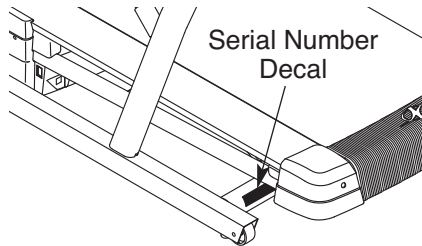

USER'S MANUAL

QUESTIONS?

As a manufacturer, we are committed to providing complete customer satisfaction. If you have questions, or if parts are damaged or missing, **DO NOT CONTACT THE STORE; please contact Customer Care.**

IMPORTANT: You must note the product model number and serial number (see the drawing above) before contacting us:

CALL TOLL-FREE:

1-888-825-2588

Mon.–Fri. 6 a.m.–6 p.m. MT

Sat. 8 a.m.–4 p.m. MT

ON THE WEB:

www.nordictrackservice.com



CAUTION

Read all precautions and instructions in this manual before using this equipment. Save this manual for future reference.

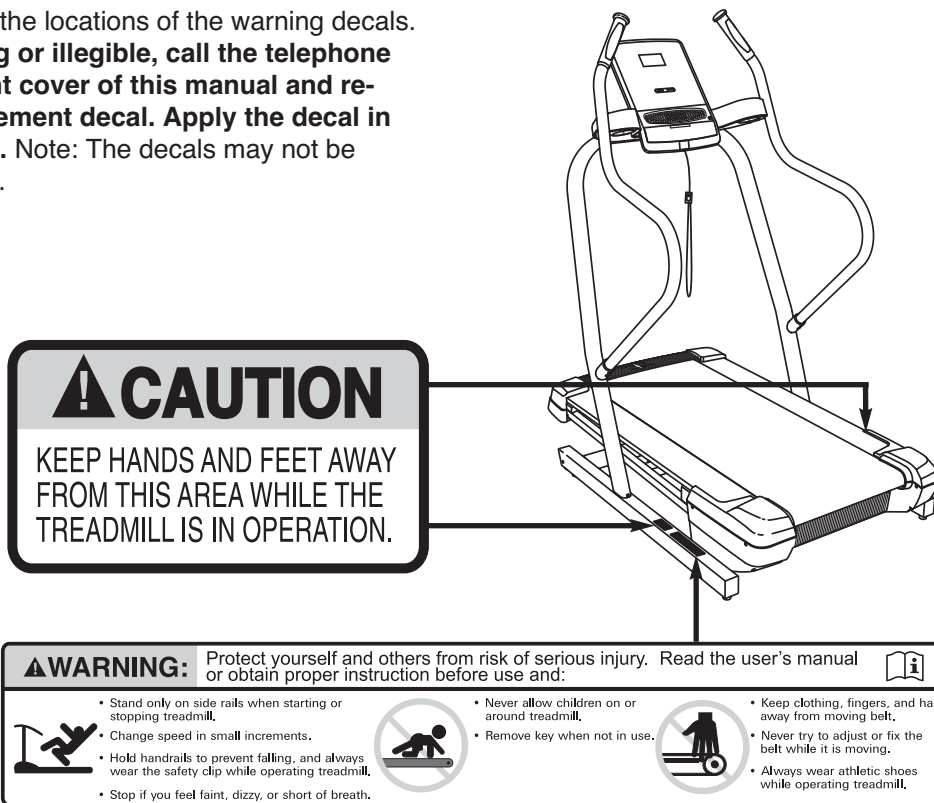

TABLE OF CONTENTS

| | |
|---------------------------------------|------------|
| WARNING DECAL PLACEMENT | .2 |
| IMPORTANT PRECAUTIONS | .3 |
| BEFORE YOU BEGIN | .5 |
| ASSEMBLY | .6 |
| OPERATION AND ADJUSTMENT | .12 |
| HOW TO MOVE THE INCLINE TRAINER | .20 |
| TROUBLESHOOTING | .21 |
| EXERCISE GUIDELINES | .24 |
| PART LIST | .26 |
| EXPLODED DRAWING | .28 |
| ORDERING REPLACEMENT PARTS | Back Cover |
| LIMITED WARRANTY | Back Cover |

WARNING DECAL PLACEMENT

This drawing shows the locations of the warning decals. **If a decal is missing or illegible, call the telephone number on the front cover of this manual and request a free replacement decal. Apply the decal in the location shown.** Note: The decals may not be shown at actual size.



IMPORTANT PRECAUTIONS

⚠️ WARNING: To reduce the risk of serious injury, read all important precautions and instructions in this manual and all warnings on your incline trainer before using your incline trainer. ICON assumes no responsibility for personal injury or property damage sustained by or through the use of this product.

1. Before beginning this or any exercise program, consult your physician. This is especially important for persons over age 35 or persons with pre-existing health problems.
2. It is the responsibility of the owner to ensure that all users of this incline trainer are adequately informed of all warnings and precautions.
3. Use the incline trainer only as described.
4. Place the incline trainer on a level surface, with at least 8 ft. (2.4 m) of clearance behind it and 2 ft. (0.6 m) on each side. Do not place the incline trainer on any surface that blocks air openings. To protect the floor or carpet from damage, place a mat under the incline trainer.
5. Keep the incline trainer indoors, away from moisture and dust. Do not put the incline trainer in a garage or covered patio, or near water.
6. Do not operate the incline trainer where aerosol products are used or where oxygen is being administered.
7. Keep children under age 12 and pets away from the incline trainer at all times.
8. The incline trainer should be used only by persons weighing 300 lbs. (136 kg) or less.
9. Never allow more than one person on the incline trainer at a time.
10. Wear appropriate exercise clothes when using the incline trainer. Do not wear loose clothes that could become caught in the incline trainer. Athletic support clothes are recommended for both men and women. *Always wear athletic shoes. Never use the incline trainer with bare feet, wearing only stockings, or in sandals.*
11. When connecting the power cord (see page 12), plug the power cord into a surge suppressor (not included) and plug the surge suppressor into a grounded circuit capable of carrying 15 or more amps. No other appliance should be on the same circuit. Do not use an extension cord.
12. Use only a single-outlet surge suppressor that meets all of the specifications described on page 12. To purchase a surge suppressor, see your local NordicTrack dealer or call the telephone number on the front cover of this manual and order part number 146148, or see your local electronics store.
13. Failure to use a properly functioning surge suppressor could result in damage to the control system of the incline trainer. If the control system is damaged, the walking belt may slow, accelerate, or stop unexpectedly, which may result in a fall and serious injury.
14. Keep the power cord and the surge suppressor away from heated surfaces.
15. Never move the walking belt while the power is turned off. Do not operate the incline trainer if the power cord or plug is damaged, or if the incline trainer is not working properly. (See TROUBLESHOOTING on page 21 if the incline trainer is not working properly.)
16. Read, understand, and test the emergency stop procedure before using the incline trainer (see HOW TO TURN ON THE POWER on page 14).
17. Never start the incline trainer while you are standing on the walking belt. Always hold the handrails while using the incline trainer.

18. The incline trainer is capable of high speeds. Adjust the speed in small increments to avoid sudden jumps in speed.
19. The pulse sensors are not medical devices. Various factors, including the user's movement, may affect the accuracy of heart rate readings. The pulse sensors are intended only as an exercise aid in determining heart rate trends in general.
20. Never leave the incline trainer unattended while it is running. Always remove the key, unplug the power cord, and switch the reset/off circuit breaker to the "off" position when the incline trainer is not in use. (See the drawing on page 5 for the location of the reset/off circuit breaker.)
21. Do not attempt to move the incline trainer until it is properly assembled. (See ASSEMBLY on page 6, and HOW TO MOVE THE INCLINE TRAINER on page 20.) You must be able to safely lift 45 lbs. (20 kg) to move the incline trainer.
22. Do not change the incline of the incline trainer by placing objects under the incline trainer.
23. Inspect and properly tighten all parts of the incline trainer regularly.
24. Never insert or drop any object into any opening on the incline trainer.
25. **DANGER:** Always unplug the power cord immediately after use, before cleaning the incline trainer, and before performing the maintenance and adjustment procedures described in this manual. Never remove the motor hood unless instructed to do so by an authorized service representative. Servicing other than the procedures in this manual should be performed by an authorized service representative only.
26. The incline trainer is intended for in-home use only. Do not use the incline trainer in any commercial, rental, or institutional setting.

SAVE THESE INSTRUCTIONS

BEFORE YOU BEGIN

Thank you for selecting the revolutionary NordicTrack® INCLINE TRAINER X3 INTERACTIVE. The INCLINE TRAINER X3 INTERACTIVE offers a selection of features designed to make your workouts at home more enjoyable and effective.

For your benefit, read this manual carefully before using the incline trainer. If you have questions after

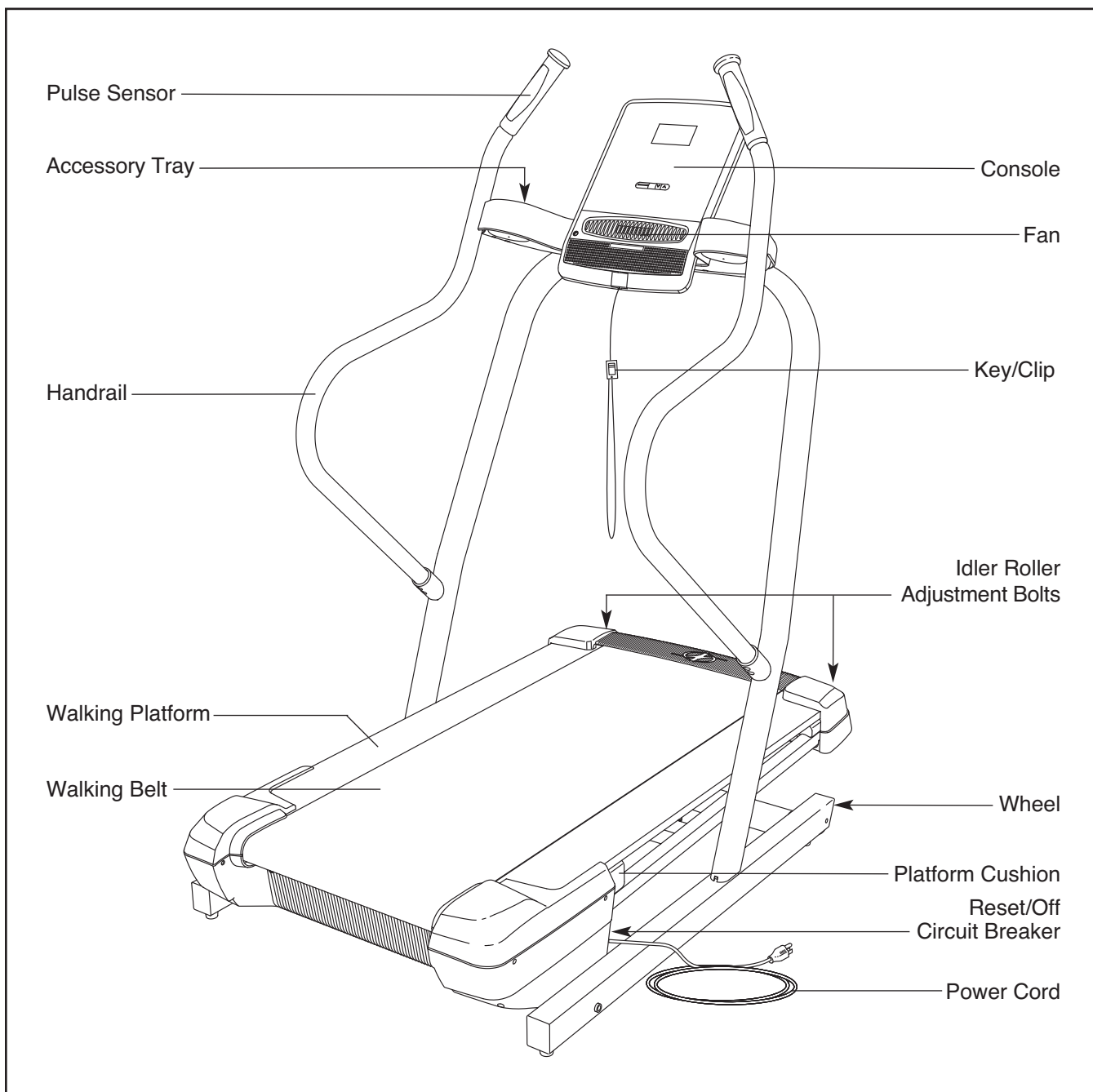

reading this manual, please see the front cover of this manual. To help us assist you, note the product model number and serial number before contacting us. The model number and the location of the serial number decal are shown on the front cover of this manual.

Before reading further, please familiarize yourself with the parts that are labeled in the drawing below.



ASSEMBLY

Assembly requires two persons. Set the incline trainer in a cleared area and remove all packing materials. **Do not dispose of the packing materials until assembly is completed.** Note: The underside of the incline trainer walking belt is coated with high-performance lubricant. During shipping, some lubricant may be transferred to the top of the walking belt or the shipping carton. This is normal and does not affect incline trainer performance. If there is lubricant on top of the walking belt, simply wipe off the lubricant with a soft cloth and a mild, non-abrasive cleaner.

Assembly requires the included hex keys  and your own Phillips screwdriver  and adjustable wrench .

Use the drawings below to identify the assembly hardware. The number in parentheses below each drawing is the key number of the part, from the PART LIST near the end of this manual. The number after the parentheses is the quantity needed for assembly. **Note: If a part is not in the hardware kit, check to see if it is preattached to one of the parts to be assembled. To avoid damaging plastic parts, do not use power tools for assembly. Extra hardware may be included.**

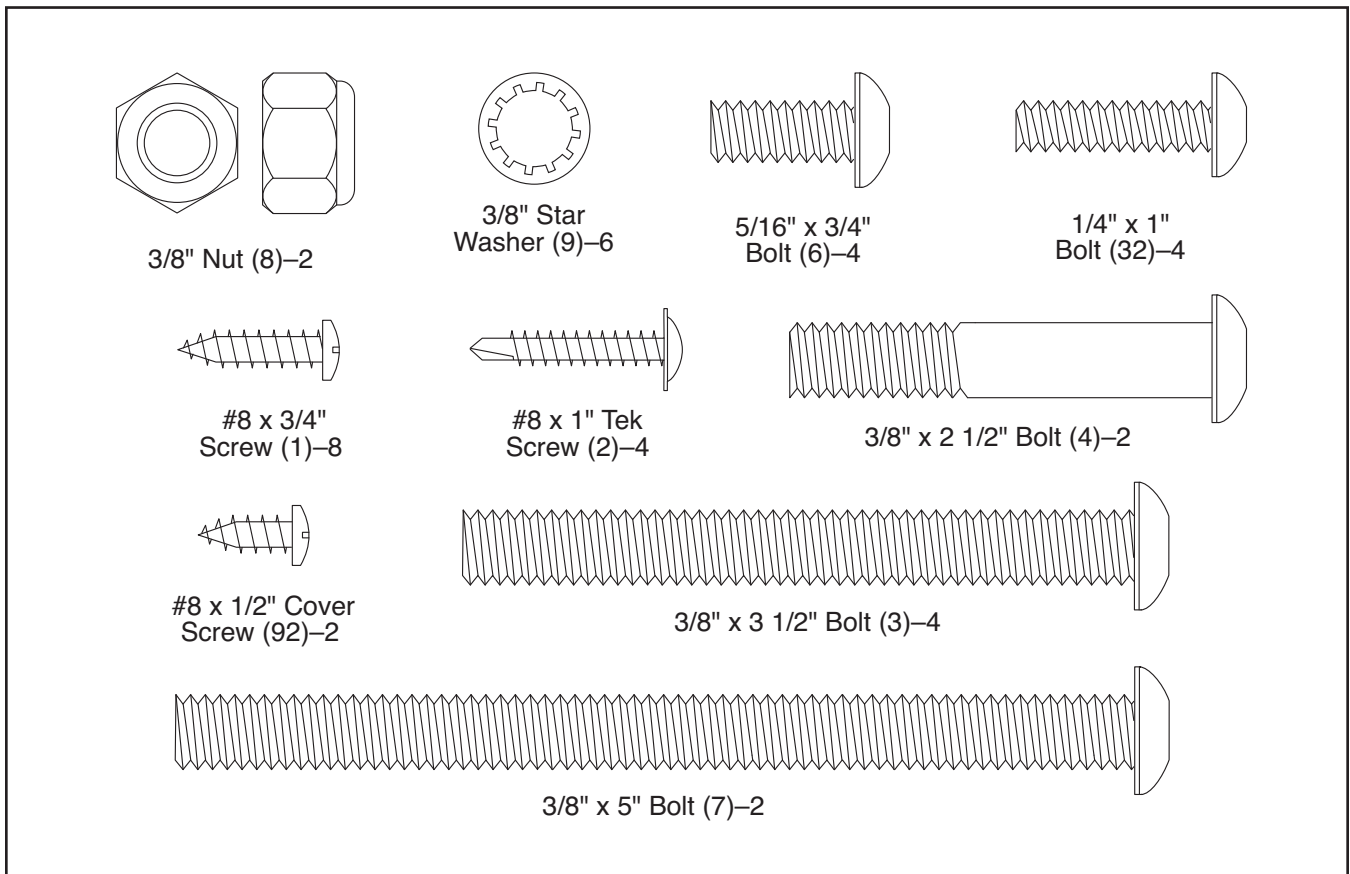

1. **Make sure that the power cord is unplugged.**

With the help of a second person, tip the incline trainer onto its left side. Have the second person hold the incline trainer to prevent it from tipping.

Attach four Base Feet (80) and four Base Foot Spacers (79) to the Base (78) with four #8 x 1" Tek Screws (2). **Be careful not to overtighten the Screws.**

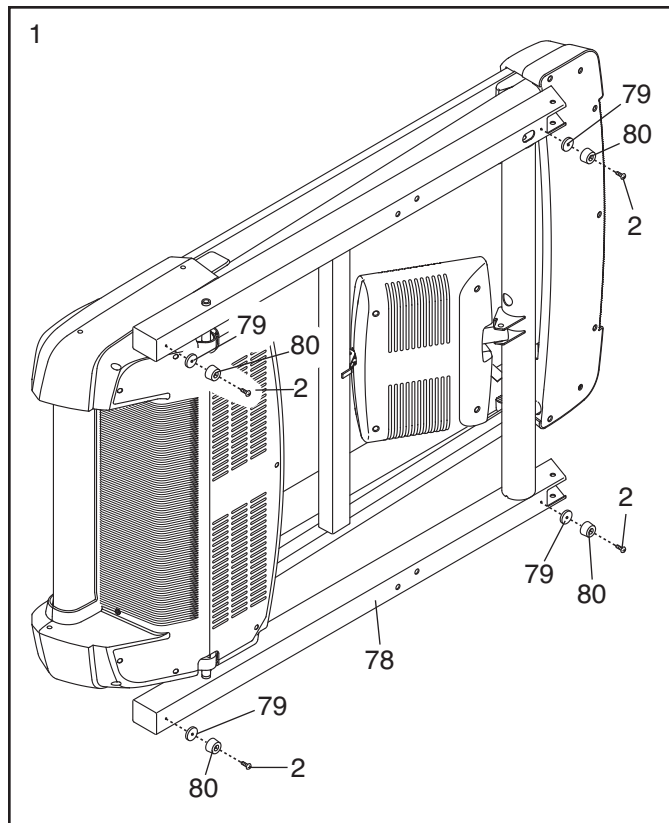

2. Hold the Upright (74) near the incline trainer, with the brackets on the Upright oriented as shown.

See the inset drawing. Wrap the wire tie in the Upright (74) around the end of the Upright Wire (72). Then, pull the other end of the wire tie until the Upright Wire is routed completely through the Upright.

Attach the Upright (74) to the Base (78) with four 3/8" x 3 1/2" Bolts (3) and four 3/8" Star Washers (9). **Start all four Bolts before tightening any of them. Be careful not to pinch the Upright Wire (72).**

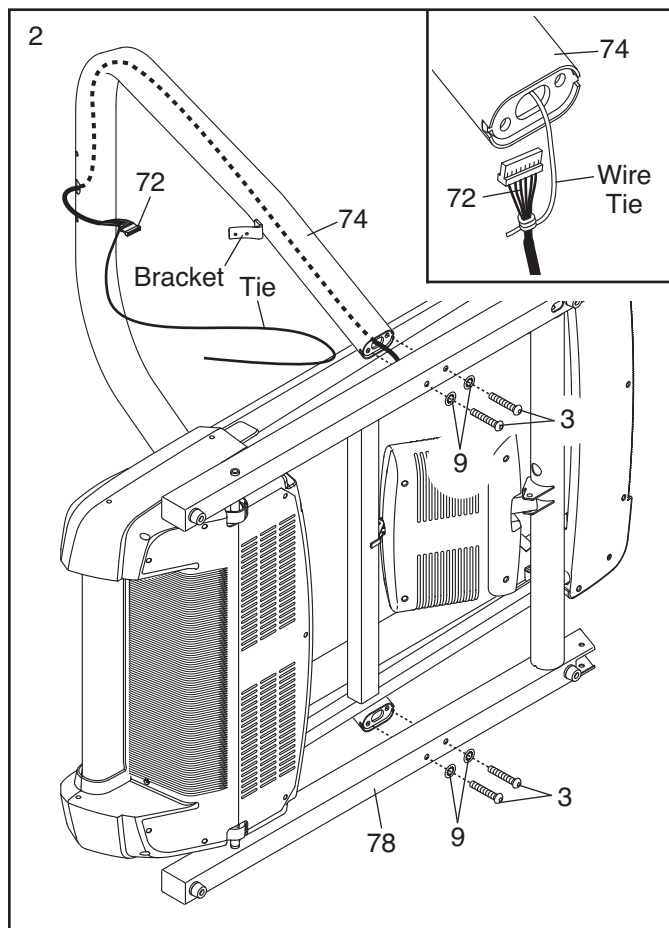

3. With the help of a second person, carefully tip the incline trainer down so that the Base (78) is flat on the floor.

Attach a Wheel (77) to each side of the Base (78) with a $\frac{3}{8}$ " x $2\frac{1}{2}$ " Bolt (4) and a $\frac{3}{8}$ " Nut (8) (only one side shown).

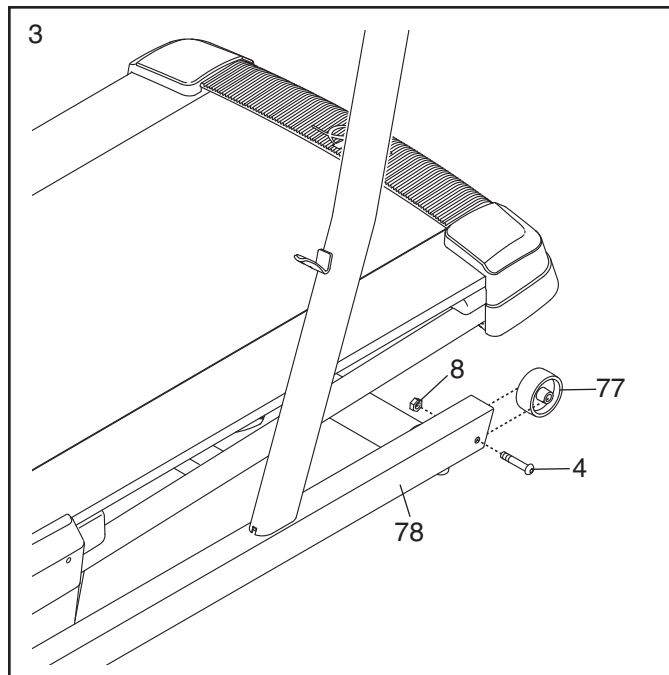

4. Hold the Yoke Spacer (87) near the Upright (74). **Make sure that the curved side of the Yoke Spacer is facing the Upright.** Insert the Upright Wire (72) through the Yoke Spacer.

Orient the Yoke (88) as shown. Insert the Upright Wire (72) through the Yoke.

Attach the Yoke (88) and the Yoke Spacer (87) to the Upright (74) with two $\frac{3}{8}$ " Star Washers (9) and two $\frac{3}{8}$ " x 5" Bolts (7); **do not fully tighten the Bolts yet.**

Remove the wire tie from the Upright Wire (72).

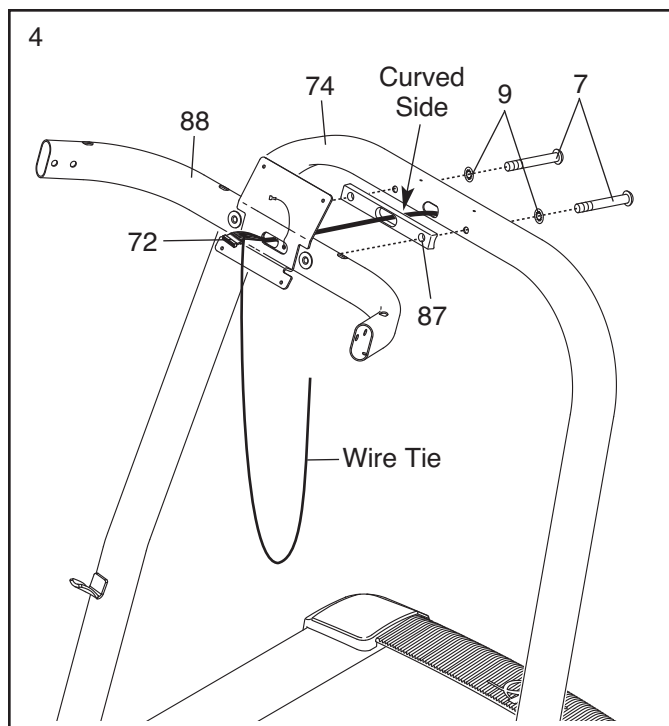

- Slide a Handrail Cover (76) onto the Left Handrail (69). **See the inset drawing. Make sure the curved side of the Handrail Cover is facing the Upright (74).**

Have a second person hold the Left Handrail (69) near the Yoke (88). Locate the wire tie inside the Yoke. Wrap the end of the wire tie around the Left Pulse Wire (70).

Pull the other end of the wire tie until the Left Pulse Wire (70) is extending from the hole in the Yoke (88). At the same time, slide the Left Handrail (69) into the Yoke. **Make sure not to pinch the Left Pulse Wire.** Then, slide the bottom of the Left Handrail onto the bracket on the Upright (74).

Attach the Left Handrail (69) to the Yoke (88) with two 5/16" x 3/4" Bolts (6); **do not fully tighten the Bolts yet.**

Slide the Handrail Cover (76) up the Left Handrail (69). Attach the Left Handrail to the Upright (74) with two 1/4" x 1" Bolts (32). **Start both Screws before tightening either of them.** Then, tighten the two 5/16" x 3/4" Bolts (6). Slide the Handrail Cover down against the Upright.

Remove the wire tie from the Left Pulse Wire (70).

Repeat this step with the Right Handrail (75), the other Handrail Cover (76), and the Right Pulse Wire (71).

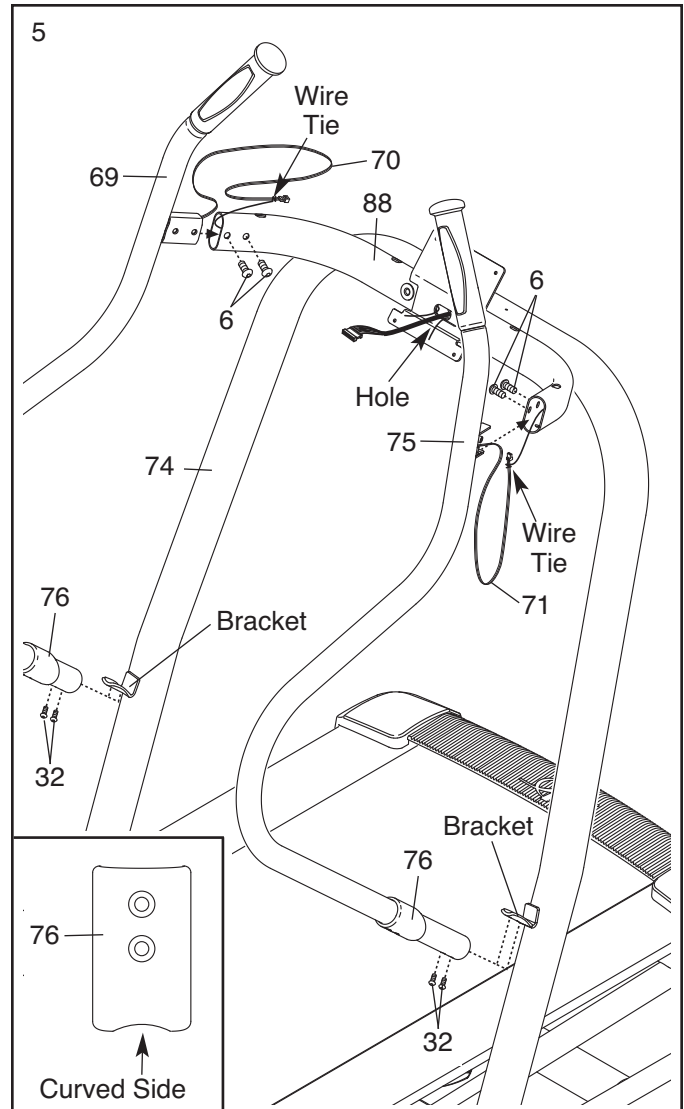

- Slide the Accessory Tray (86) onto the Yoke (88). Partially insert the two indicated tabs and then partially insert the other tabs. Then, fully insert all of the tabs. **Make sure not to break the tabs.**

Attach the Accessory Tray (86) to the Yoke (88) with four #8 x 3/4" Screws (1). **Start all four Screws before tightening any of them. Do not overtighten the Screws.**

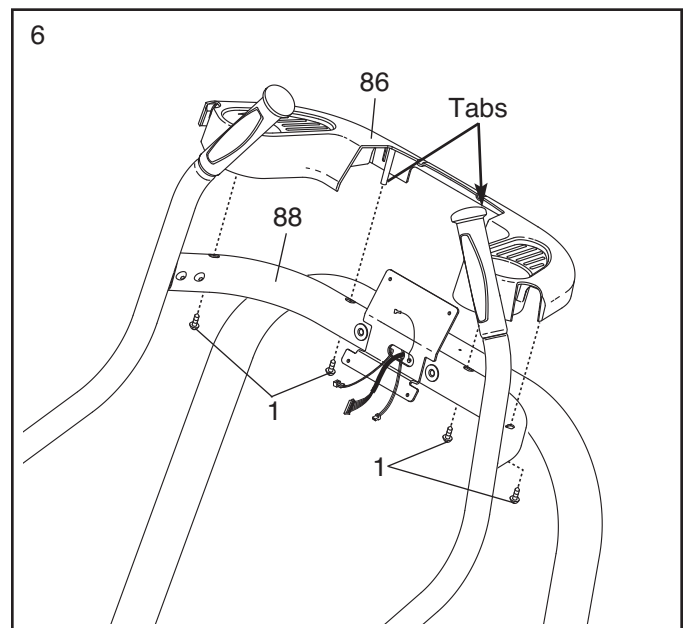

7. Have a second person hold the Console (84) near the Yoke (88). Connect the Upright Wire (72), the Left and Right Pulse Wires (70, 71), and the Console Ground Wire (89) to the wires extending from the Console. **See the inset drawing. The connectors should slide together easily and snap into place. If they do not, turn one connector and try again. IF THE CONNECTORS ARE NOT CONNECTED PROPERLY, THE CONSOLE MAY BE DAMAGED WHEN THE POWER IS TURNED ON.**

Insert the excess wire into the Console (84).

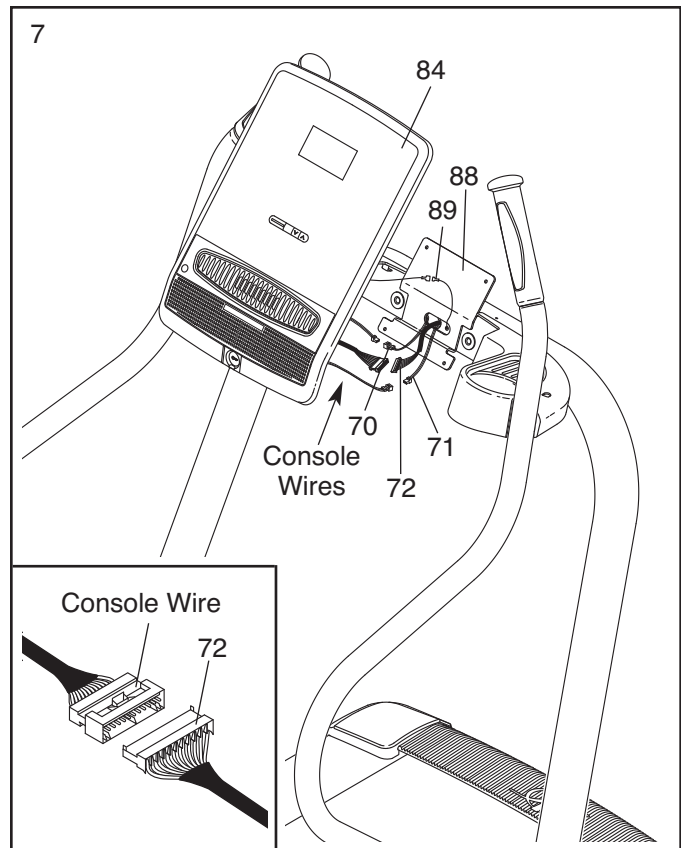

8. Attach the Console (84) to the plate on the Yoke (88) with four #8 x 3/4" Screws (1). **Be careful not to pinch any wires. Start all four Screws before tightening any of them. Do not over-tighten the Screws.**

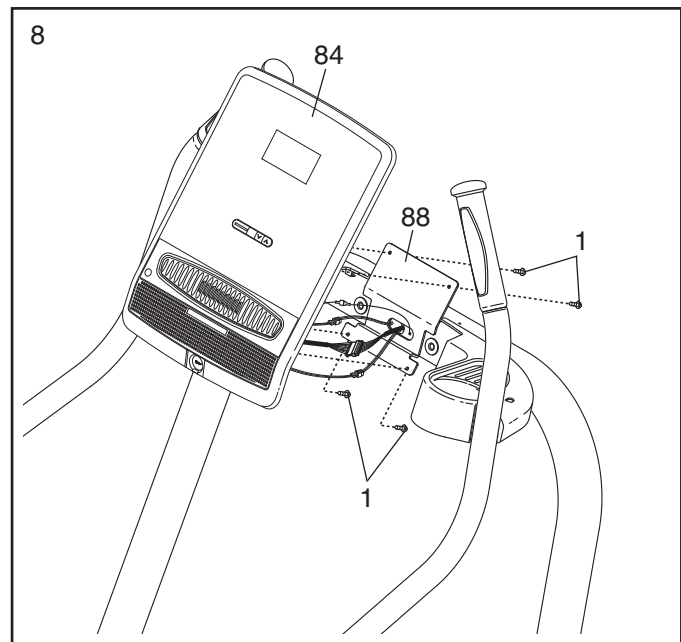

9. **Tighten the 3/8" x 5" Bolts (7).**

Attach the Console Cover (73) to the top of the Upright (74) with two #8 x 1/2" Cover Screws (92). **Do not overtighten the Screws.**

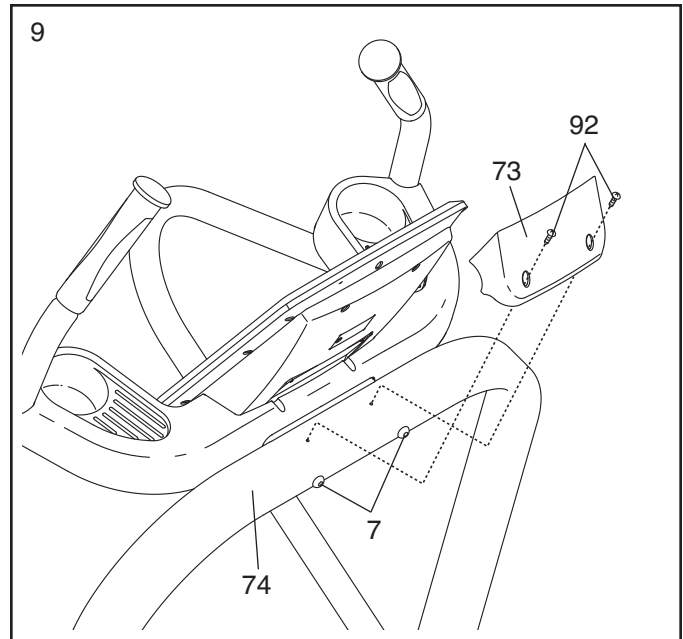

10. **Make sure that all parts are properly tightened before you use the incline trainer.** Keep the included hex keys in a secure place. A hex key is used to adjust the walking belt (see pages 22 and 23). **To protect the floor or carpet from damage, place a mat under the incline trainer.**

If you purchase the optional chest pulse sensor (see page 19), follow the steps below to install the receiver included with the chest pulse sensor.

1. **Make sure that the power cord is unplugged.** Remove the indicated #8 x 3/4" Screw (1) from the Access Door (90) on the back of the Console (84).
2. **See the lower drawing. Hold the receiver so that the antenna is oriented as shown.** Peel the paper backing off the back of the receiver. Press the receiver onto the Access Door (90) in the location shown.
3. Connect the wire on the receiver to the wire extending from the Console (84). **Make sure that no wires are pinched.** Reattach the Access Door (90) to the Console with the #8 x 3/4" Screw (1). Discard the other wires included with the receiver.

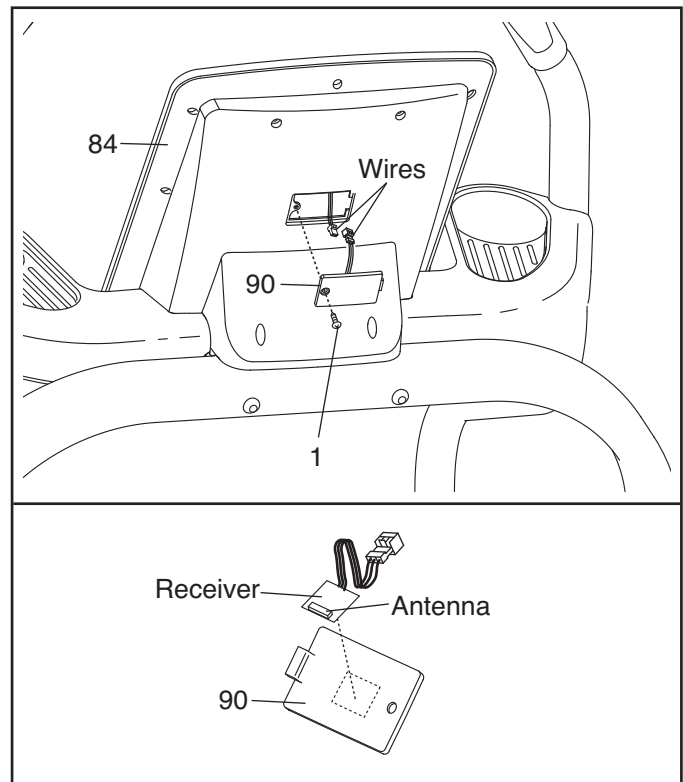

OPERATION AND ADJUSTMENT

THE PRE-LUBRICATED WALKING BELT

Your incline trainer features a walking belt coated with high-performance lubricant. **IMPORTANT: Never apply silicone spray or other substances to the walking belt or the walking platform. Such substances will deteriorate the walking belt and cause excessive wear.**

HOW TO PLUG IN THE POWER CORD

⚠ DANGER: Improper connection of the equipment-grounding conductor can result in an increased risk of electric shock. Check with a qualified electrician or serviceman if you are in doubt as to whether the product is properly grounded. Do not modify the plug provided with the product—if it will not fit the outlet, have a proper outlet installed by a qualified electrician.

Your incline trainer, like any other type of sophisticated electronic equipment, can be seriously damaged by sudden voltage changes in your home's power. Voltage surges, spikes, and noise interference can result from weather conditions or from other appliances being turned on or off. **To decrease the possibility of your incline trainer being damaged, always use a surge suppressor with your incline trainer (see drawing 1 at the right).** To purchase a surge suppressor, see your local NordicTrack dealer or call the telephone number on the front cover of this manual and order part number 146148, or see your local electronics store.

Use only a single-outlet surge suppressor that is UL 1449 listed as a transient voltage surge suppressor (TVSS). The surge suppressor must have a UL suppressed voltage rating of 400 volts or less and a minimum surge dissipation of 450 joules. The surge suppressor must be electrically rated for 120 volts AC and 15 amps. There must be a monitoring light on the surge suppressor to indicate whether it is functioning properly. Failure to use a properly functioning surge suppressor could result in damage to the control system of the incline trainer. If the control system is damaged, the walking belt may slow, accelerate, or stop unexpectedly, which may result in a fall and serious injury.

This product must be grounded. If it should malfunction or break down, grounding provides a path of least resistance for electric current to reduce the risk of elec-

tric shock. This product is equipped with a cord having an equipment-grounding conductor and a grounding plug. **Plug the power cord into a surge suppressor, and plug the surge suppressor into an appropriate outlet that is properly installed and grounded in accordance with all local codes and ordinances. IMPORTANT: The incline trainer is not compatible with GFCI-equipped outlets.**

This product is for use on a nominal 120-volt circuit, and has a grounding plug that looks like the plug illustrated in drawing 1 below. A temporary adapter that looks like the adapter illustrated in drawing 2 may be used to connect the surge suppressor to a 2-pole receptacle as shown in drawing 2 if a properly grounded outlet is not available.

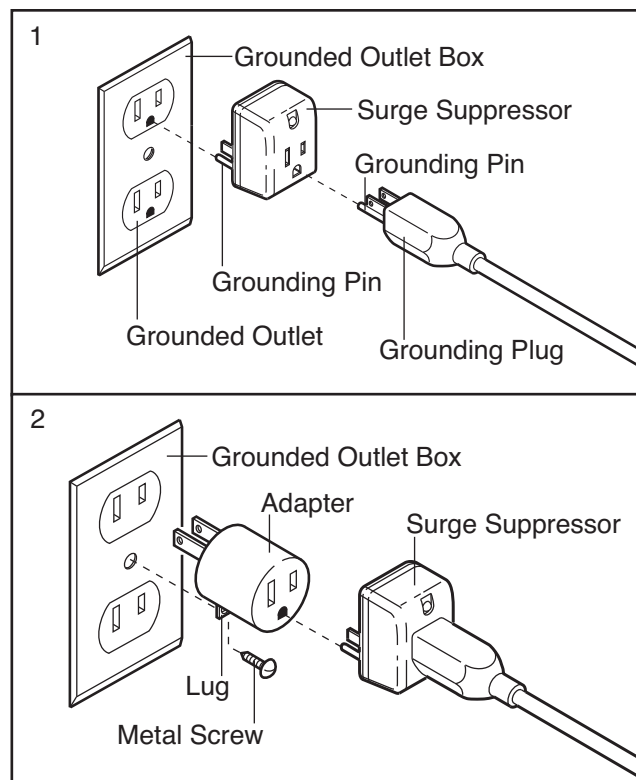

The temporary adapter should be used only until a properly grounded outlet (drawing 1) can be installed by a qualified electrician.

The green-colored rigid ear, lug, or the like extending from the adapter must be connected to a permanent ground such as a properly grounded outlet box cover. Whenever the adapter is used it must be held in place by a metal screw. **Some 2-pole receptacle outlet box covers are not grounded. Contact a qualified electrician to determine if the outlet box cover is grounded before using an adapter.**

CONSOLE DIAGRAM

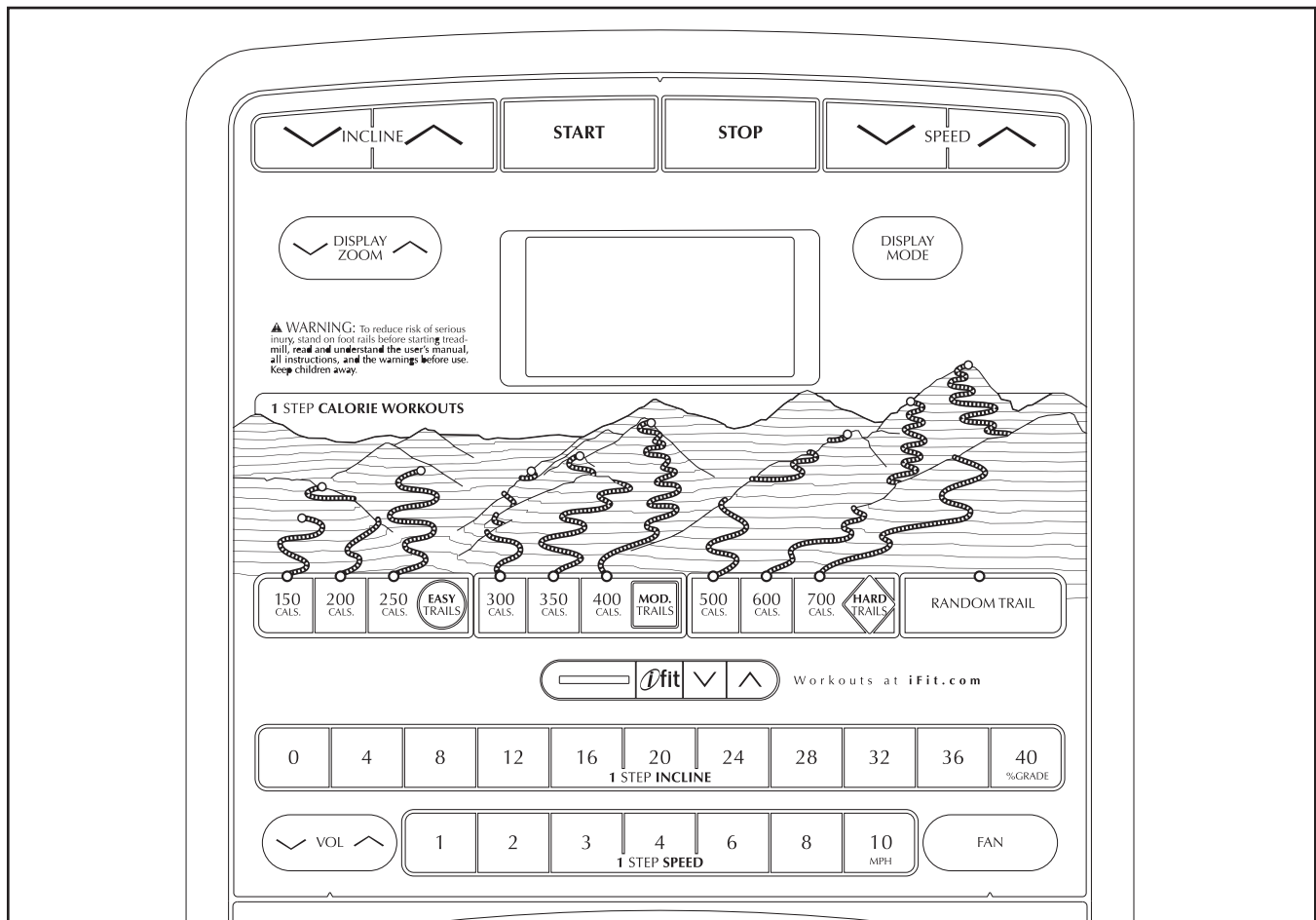

FEATURES OF THE CONSOLE

The incline trainer console offers an impressive array of features designed to make your workouts more effective and enjoyable. When the manual mode of the console is selected, the speed and incline of the incline trainer can be changed with the touch of a button. As you exercise, the console will display continuous exercise feedback. You can even measure your heart rate using the handgrip pulse sensor or the optional chest pulse sensor (see page 19 for information on the optional chest pulse sensor).

In addition, the console features nine 1 step calorie workouts. Each workout automatically controls the speed and incline of the incline trainer as it guides you through an effective exercise session. You can even use the random workout generator to get a new workout every time you exercise.

The console also features the new iFit interactive workout system. The iFit system enables the console to ac-

cept iFit interactive workout cards containing workouts designed to help you achieve specific fitness goals. iFit workouts automatically control the incline trainer while the voice of a personal trainer coaches you through every step of your workout. iFit cards are available separately. **To purchase iFit cards at any time, please see the front cover of this manual or go to www.iFit.com. iFit cards are also available at select stores.**

You can also listen to your favorite workout music or audio books with the console's premium stereo sound system while you get in shape.

To turn on the power, see page 14. To use the manual mode, see page 14. To use a 1 step calorie workout, see page 16. To use a random workout, see page 17. To use an iFit card, see page 18. To use the information mode, see page 19. To use the stereo sound system, see page 19.

HOW TO TURN ON THE POWER

IMPORTANT: If the incline trainer has been exposed to cold temperatures, allow it to warm to room temperature before turning on the power. If you do not do this, you may damage the console displays or other electrical components.

Plug in the power cord (see page 12). Next, locate the reset/off circuit breaker on the incline trainer frame near the power cord. Make sure that the circuit breaker is in the “reset” position.

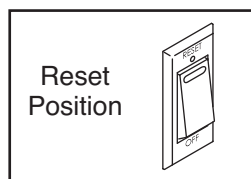

IMPORTANT: The console features a display demo mode, designed to be used if the incline trainer is displayed in a store. If the displays light as soon as you plug in the power cord and switch the reset/off circuit breaker to the reset position, the demo mode is turned on. To turn off the demo mode, hold down the Stop button for a few seconds. If the displays remain lit, see **THE INFORMATION MODE** on page 19 to turn off the demo mode. If the console is in demo mode, the incline will automatically rise to the maximum incline level.

Next, stand on the walking platform of the incline trainer. Locate the clip attached to the key (see the drawing at the right), and slide the clip securely onto the waistband of your clothes. Then, insert the key into the console.

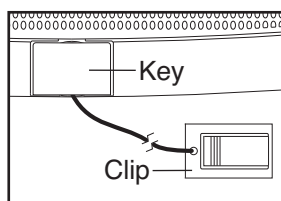

After a moment, the displays will light. **IMPORTANT:** In an emergency situation, the key can be pulled from the console, causing the walking belt to slow to a stop. Test the clip by carefully taking a few steps backward; if the key is not pulled from the console, adjust the position of the clip.

IMPORTANT: If there is a sheet of clear plastic on the face of the console, remove the plastic. To prevent damage to the walking platform, wear clean athletic shoes while using the incline trainer. The first time the incline trainer is used, observe the alignment of the walking belt, and center the walking belt if necessary (see page 23).

Note: The console can display speed and distance in either miles or kilometers. To find which unit of measurement is selected, see **THE INFORMATION MODE** on page 19. For simplicity, all instructions in this manual refer to miles.

HOW TO USE THE MANUAL MODE

1. Insert the key into the console.

See **HOW TO TURN ON THE POWER** at the left. If necessary, press the Incline buttons to lower the incline to the minimum incline level.

2. Select the manual mode.

Each time the key is inserted, the manual mode will be selected. If you have selected a workout, press any of the workout buttons repeatedly until the words **MANUAL CONTROL** appear in the display.

3. Start the walking belt and adjust the speed.

To start the walking belt, press the Start button, the Speed increase button, or one of the 1 Step Speed buttons numbered 1 to 10.

If you press the Start button or the Speed increase button, the walking belt will begin to move at 1 mph. As you exercise, change the speed of the walking belt as desired by pressing the Speed increase and decrease buttons next to the Start button. Each time you press a button, the speed setting will change by 0.1 mph; if you hold down a button, the speed setting will change in increments of 0.5 mph. If you press one of the numbered 1 Step Speed buttons, the walking belt will gradually change speed until it reaches the selected speed setting.

To stop the walking belt, press the Stop button. To restart the walking belt, press the Start button, the Speed increase button, or one of the numbered 1 Step Speed buttons.

4. Change the incline of the incline trainer as desired.

To change the incline of the incline trainer, press the Incline increase and decrease buttons or one of the 1 Step Incline buttons numbered 0 to 40. Each time you press one of the buttons, the incline will gradually change until it reaches the selected incline setting. As the incline increases, the maximum speed of the incline trainer will decrease.

5. Monitor your progress with the display.

When the manual mode is selected, the console offers four display modes. The display mode that you select will determine which workout information is shown. Press the Display Mode button repeatedly to select the desired display mode.

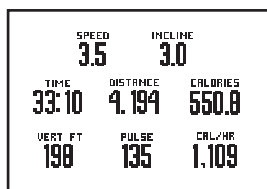

As you walk or run on the incline trainer, the display can show the following workout information:

- The elapsed time.
- The distance that you have walked or run.
- The number of vertical feet you have climbed.
- The approximate number of calories burned per hour.
- The speed of the walking belt.
- The incline level of the incline trainer.
- The approximate number of calories you have burned.
- Your heart rate. Note: Your heart rate can be displayed only while you use the handgrip pulse sensor or the optional chest pulse sensor (see step 6).

Regardless of which display mode you select, the speed or incline setting will appear in the display for a few seconds each time you change the setting.

If desired, adjust the volume by pressing the Volume (VOL) increase and decrease buttons on the console.

To reset the console, press the Stop button, remove the key, and then reinsert the key.

6. Measure your heart rate if desired.

Note: If you use the handgrip pulse sensor and the optional chest pulse sensor at the same

time, the console will not display your heart rate accurately. For information on the optional chest pulse sensor, see page 19.

Before using the handgrip pulse sensor, remove the sheets of clear plastic from the metal contacts if necessary. In addition, make sure that your hands are clean.

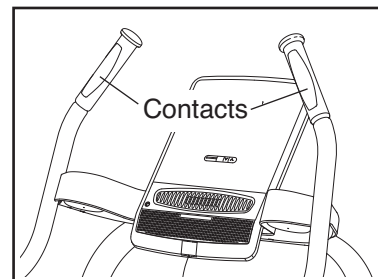

To measure your heart rate, **stand on the walking platform** and hold the metal contacts on the handrail—**avoid moving your hands**. Hold the contacts for approximately ten seconds. When your pulse is detected, your heart rate will be shown. **For the most accurate heart rate reading, continue to hold the contacts for about 15 seconds.**

7. Turn on the fan if desired.

The fan has high and low speed settings. Press the Fan button repeatedly to select a fan speed or to turn off the fan. Note: If the fan is on when the walking belt stops, the fan will automatically turn off after a few minutes.

8. When you are finished exercising, remove the key from the console.

Step onto the walking platform and press the Stop button. Next, remove the key from the console and put it in a secure place. If the console is in demo mode (see THE INFORMATION MODE on page 19), the incline will automatically rise to the maximum incline level.

When you are finished using the incline trainer, switch the reset/off circuit breaker to the “off” position and unplug the power cord. **IMPORTANT: If you do not do this, the incline trainer’s electrical components may wear prematurely.**

HOW TO USE A 1 STEP CALORIE WORKOUT

1. Insert the key into the console.

See step 1 on page 14.

2. Select a 1 step calorie workout.

To select a 1 step calorie workout, press one of the 1 Step Calorie Workouts buttons until the name of the desired workout appears in the display and the light at the bottom of the desired trail lights up.

When a workout is selected, the display will show a trail on the side of a mountain.

Each workout is divided into segments. One speed setting and one incline setting are programmed for each segment. Note: The same speed setting or incline setting may be programmed for consecutive segments.

3. Start the walking belt.

Press the Start button to start the workout. A moment after you press the button, the incline trainer will begin to move. Hold the handrails and begin walking.

At the end of the first segment of the workout, a series of tones will sound. If a different speed and/or incline setting is programmed for the second segment, the speed setting and/or incline setting will appear in the display for a moment to alert you and the incline trainer will automatically adjust to the speed and incline settings for the next segment.

The workout will continue in this way until you reach the end of the trail on the display. The walking belt will then slow to a stop.

If the speed or incline setting is too high or too low at any time during the workout, you can override the setting by pressing the Speed or Incline buttons; **however, when the next segment begins, the incline trainer will automatically adjust to the speed and incline settings for the next segment.**

To stop the workout at any time, press the Stop button. To restart the workout, press the Start button. The walking belt will begin to move at 1 mph. When the next segment of the workout begins, the incline trainer will automatically adjust to the speed and incline settings for the next segment.

Note: The calorie goal is an estimate of the number of calories that you will burn during the program. The actual number of calories that you burn will depend on your weight. In addition, if you manually change the speed or incline of the incline trainer during the program, the number of calories you burn will be affected.

4. Monitor your progress with the display.

See step 5 on page 15. When a 1 step calorie workout is selected, the console offers four display modes. Press the Display Mode button repeatedly to select the desired display mode.

The display will show an animation of the trail you are walking or running. The circle above the trail will show your progress. Press the Display Zoom increase and decrease buttons to zoom in or zoom out. In the display that shows an animation of a runner, the incline profile represents the incline level of the trail and the right side of the display will show the number of vertical feet you have climbed.

To adjust the contrast of the display, see THE INFORMATION MODE on page 19.

5. Measure your heart rate if desired.

See step 6 on page 15.

6. Turn on the fan if desired.

See step 7 on page 15.

7. When you are finished exercising, remove the key from the console.

See step 8 on page 15.

HOW TO USE A RANDOM WORKOUT

1. Insert the key into the console.

See step 1 on page 14.

2. Select a random workout.

To select a random workout, press the Random Trail button. The incline trainer will create a new workout based on random speed and incline settings.

When a random workout is selected, the display will show a profile of the incline settings and a profile of the speed settings of the workout. In addition, the display will show the maximum incline setting, duration, and maximum speed setting of the workout.

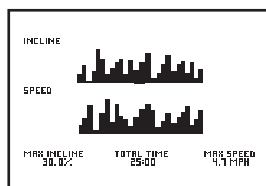

Each random workout is divided into one-minute segments. One speed setting and one incline setting are programmed for each segment. Note: The same speed setting and/or incline setting may be programmed for consecutive segments.

3. Start the walking belt.

Press the Start button to start the workout. A moment after you press the button, the incline trainer will automatically adjust to the first speed and incline settings of the workout. Hold the handrails and begin walking.

During the workout, the profiles will show your progress. The flashing segments of the profiles represent the current segment of the workout. The height of the flashing segment indicates the speed setting or the incline setting for the current segment. At the end of each segment, a series of tones will sound and the next segment of the profiles will begin to flash. If a different speed and/or incline setting is programmed for the next segment of the workout, the new speed and/or incline setting will appear in the display to alert you. The incline trainer will then automatically adjust to the speed and/or incline setting for the next segment.

The workout will continue in this way until the last segments of the profiles flash in the display and the last segment ends. The walking belt will then slow to a stop.

If the speed or incline setting for the current segment is too high or too low, you can manually override the setting by pressing the Speed or Incline buttons; **however, when the current segment of the workout ends, the incline trainer will automatically adjust to the speed and incline settings for the next segment.**

To stop the workout at any time, press the Stop button. To restart the workout, press the Start button or the Speed increase button. The walking belt will begin to move at 1 mph. When the next segment of the workout begins, the incline trainer will automatically adjust to the speed and incline settings for the next segment.

4. Monitor your progress with the display.

When a random workout is selected, the console offers three display modes. Press the Display Mode button repeatedly to select the desired display mode. The display can show profiles of the speed and incline settings of the workout, the time remaining in the workout, the distance you have walked or run, the approximate number of calories you have burned, the speed of the walking belt, and the incline of the incline trainer.

5. Measure your heart rate if desired.

See step 6 on page 15.

6. Turn on the fan if desired.

See step 7 on page 15.

7. When you are finished exercising, remove the key from the console.

See step 8 on page 15.

HOW TO USE AN IFIT CARD

1. Insert the key into the console.

See step 1 on page 14.

2. Insert an iFit card and select a workout.

To use an iFit workout, insert an iFit card into the iFit slot; make sure that the iFit card is oriented so the metal contacts are face-down and are inserted into the iFit slot.

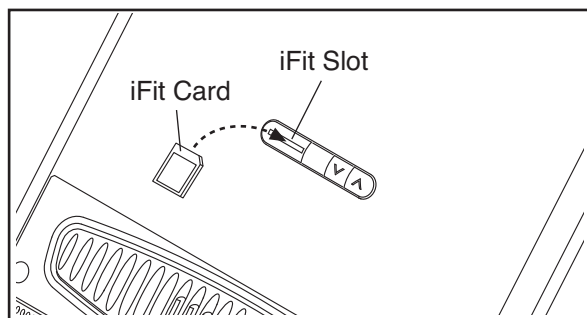

Next, select an iFit workout by pressing the iFit increase or decrease button. When an iFit workout is selected, the display will show a profile of the speed settings of the workout. In addition, the display will show the maximum incline setting, duration, and maximum speed setting of the workout.

Each iFit workout is divided into several one-minute segments. One speed setting and one incline setting are programmed for each segment. Note: The same speed and/or incline setting may be programmed for consecutive segments.

3. Start the walking belt.

Press the Start button to start the workout. A moment after you press the button, the incline trainer will automatically adjust to the first speed and incline settings of the workout. Hold the handrails and begin walking.

During the workout, the voice of a personal trainer will guide you through the workout. The iFit workout

will function in the same way as a random workout (see page 17).

If the speed or incline setting for the current segment is too high or too low, you can override the setting by pressing the Speed or Incline buttons; **however, when the next segment begins, the incline trainer will automatically adjust to the speed and incline settings for the next segment.**

To stop the workout at any time, press the Stop button. To restart the workout, press the Start button. The walking belt will begin to move at 1 mph. When the next segment of the workout begins, the incline trainer will automatically adjust to the speed and incline settings for the next segment.

4. Monitor your progress with the display.

When an iFit workout is selected, the console offers three display modes. Press the Display Mode button repeatedly to select the desired display mode. The display can show a profile of the speed settings of the workout, the time remaining in the workout, the distance you have walked or run, the approximate number of calories you have burned, the speed of the walking belt, and the incline of the incline trainer.

5. Turn on the fan if desired.

See step 6 on page 15.

6. When you are finished exercising, remove the key from the console.

See step 7 on page 15.

CAUTION: Always remove iFit cards from the iFit slot when you are not using them.

THE INFORMATION MODE

The console features an information mode that keeps track of the total distance that the walking belt has moved and the total number of hours that the treadmill has been used. The information mode also allows you to select miles or kilometers to measure distance, and to turn on and turn off the display demo mode. You can also adjust the contrast level of the display.

To select the information mode, hold down the Stop button, insert the key into the console, and then release the Stop button. When the information mode is selected, the following information will appear in the display:

The display will show the total number of hours the treadmill has been used and the total number of miles that the walking belt has moved.

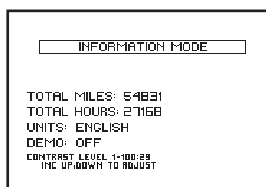

The display will show the selected unit of measurement. To change the unit of measurement, press the Speed increase button. To view distance in miles, select ENGLISH. To view distance in kilometers, select METRIC.

The console features a display demo mode, designed to be used if the incline trainer is displayed in a store. While the demo mode is turned on, the console will function normally when you plug in the power cord, switch the reset/off circuit breaker to the reset position, and insert the key into the console. However, when you remove the key, the displays will remain lit, although the buttons will not function. If the demo mode is turned on, the word "ON" will appear in display while the information mode is selected. To turn on or turn off the demo mode, press the Speed decrease button. Note: When the incline trainer is in the demo mode, the incline will automatically rise to the maximum incline level.

The display will also show the contrast level of the display. Press the Incline increase and decrease buttons to adjust the contrast.

To exit the information mode, remove the key from the console.

HOW TO USE THE STEREO SOUND SYSTEM

To play music or audio books through the console's speakers, you must connect your MP3 player, CD player, or other personal audio player to the console.

Locate the audio wire. Plug one end into the audio jack near the speakers. Then, plug the audio wire into a jack on your MP3 player, CD player, or personal audio player. **Make sure that the audio wire is fully plugged in.**

Next, press the Play button on your MP3 player, CD player, or other personal audio player. Then, adjust the volume on your personal audio player or press the Volume (VOL) increase and decrease buttons on the console.

If you are using a personal CD player and the CD skips, set the CD player on the floor or another flat surface instead of on the console.

THE OPTIONAL CHEST PULSE SENSOR

An optional chest pulse sensor offers hands-free operation as it tracks your heart rate during your workouts. **To purchase the optional chest pulse sensor, see the front cover of this manual.**

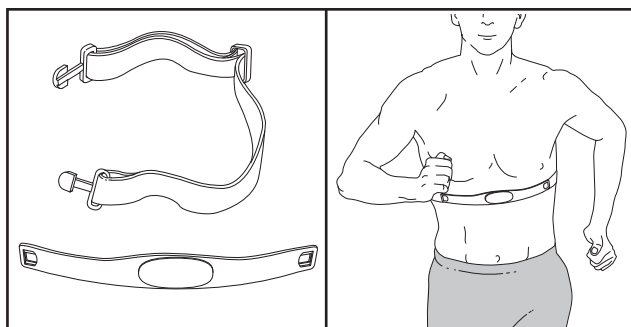

HOW TO MOVE THE INCLINE TRAINER

Before moving the incline trainer, insert the key into the console, raise the incline to the maximum incline level, remove the key, and unplug the power cord.

Due to the size and weight of the incline trainer, moving it requires two or three persons. Hold the upright firmly near the console. **CAUTION:** To decrease the possibility of damage to the incline trainer or of injury, do not lift the incline trainer by the plastic belly pan. Do not pull on the console. Carefully roll the incline trainer on the wheels to the desired location and then lower it to the level position. **CAUTION:** To reduce the risk of injury, use extreme caution while moving the incline trainer. Do not attempt to move the incline trainer over uneven surfaces.

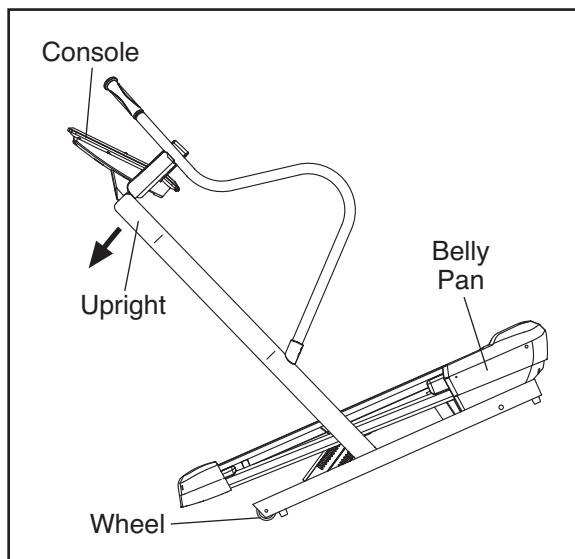

TROUBLESHOOTING

Most incline trainer problems can be solved by following the steps below. Find the symptom that applies, and follow the steps listed. If further assistance is needed, please see the front cover of this manual.

PROBLEM: The power does not turn on

SOLUTION: a. Make sure that the power cord is plugged into a surge suppressor, and that the surge suppressor is plugged into a properly grounded outlet (see page 12). Use only a single-outlet surge suppressor that meets all of the specifications described on page 12. **IMPORTANT: The incline trainer is not compatible with GFCI-equipped outlets.**

b. After the power cord has been plugged in, make sure that the key is inserted into the console.

c. Check the reset/off circuit breaker located on the incline trainer frame near the power cord. If the switch protrudes as shown, the circuit breaker has tripped. To reset the circuit breaker, wait for five minutes and then press the switch to the reset position.

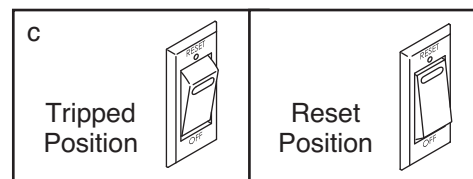

PROBLEM: The power turns off during use

SOLUTION: a. Check the reset/off circuit breaker (see the drawing above). If the circuit breaker has tripped, wait for five minutes and then press the switch to the reset position.

b. Make sure that the power cord is plugged in. If the power cord is plugged in, unplug it, wait for five minutes, and then plug it back in.

c. Remove the key from the console. Reinsert the key into the console.

d. If the incline trainer still will not run, please see the front cover of this manual.

PROBLEM: The console displays remain lit when you remove the key from the console

SOLUTION: a. The console features a display demo mode, designed to be used if the incline trainer is displayed in a store. If the displays remain lit when you remove the key and the incline rises to the maximum level, the demo mode is turned on. To turn off the demo mode, hold down the Stop button for a few seconds. If the displays are still lit, see THE INFORMATION MODE on page 19 to turn off the demo mode.

PROBLEM: The displays of the console do not function properly

SOLUTION: a. Remove the key from the console and **UNPLUG THE POWER CORD**. Remove the three indicated #8 x 3/4" Screws (1). Lift off the Left Roller Cover (35).

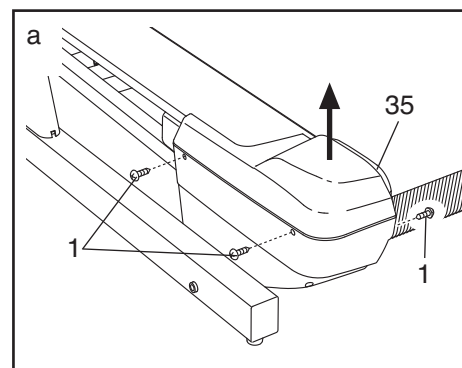

Locate the Reed Switch (49) and the Magnet (37) on the left side of the Pulley (38). Turn the Pulley until the Magnet is aligned with the Reed Switch. **Make sure that the gap between the Magnet and the Reed Switch is about 1/8 in. (3 mm).** If necessary, loosen the #8 x 3/4" Clamp Screw (13), move the Reed Switch slightly, and then retighten the Screw. Reattach the Left Roller Cover (not shown) and run the incline trainer for a few minutes to check for a correct speed reading.

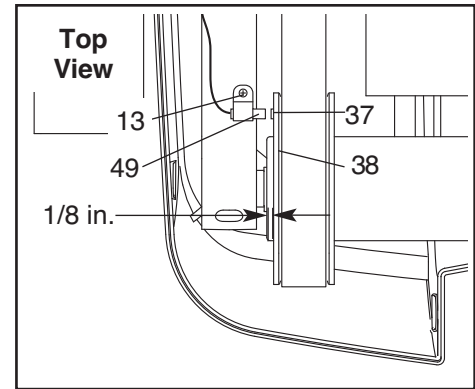

PROBLEM: The incline of the incline trainer does not change correctly

SOLUTION: a. Hold down the Stop button and the Speed increase button, insert the key into the console, and then release the Stop button and the Speed increase button. Press the Stop button again. Then, press the Incline increase or decrease button. The incline trainer will automatically rise to the maximum incline level and then return to the minimum level. This will recalibrate the incline system. If the incline does not calibrate, press the Stop button, and then press the Incline increase or decrease button again. When the incline is calibrated, remove the key from the console.

PROBLEM: The walking belt slows when walked on

SOLUTION: a. Use only a single-outlet surge suppressor that meets all of the specifications described on page 12.

b. If the walking belt is overtightened, incline trainer performance may decrease and the walking belt may become damaged. Remove the key and **UNPLUG THE POWER CORD**. Using the hex key, turn both idler roller bolts counterclockwise, 1/4 of a turn. When the walking belt is properly tightened, you should be able to lift each edge of the walking belt 3 to 4 in. (8 to 10 cm) off the walking platform. Be careful to keep the walking belt centered. Then, plug in the power cord, insert the key, and run the incline trainer for a few minutes. Repeat until the walking belt is properly tightened.

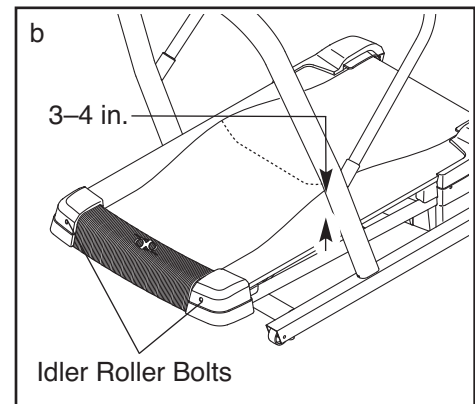

c. If the walking belt still slows when walked on, please see the front cover of this manual.

PROBLEM: The walking belt is off-center or slips when walked on

SOLUTION: a. If the walking belt is off-center, remove the key and **UNPLUG THE POWER CORD**. If the walking belt has shifted to the left, use the hex key to turn the left idler roller bolt clockwise 1/2 of a turn; if the walking belt has shifted to the right, turn the bolt counterclockwise 1/2 of a turn. Be careful not to over-tighten the walking belt. Plug in the power cord, insert the key, and run the incline trainer for a few minutes. Repeat until the walking belt is centered.

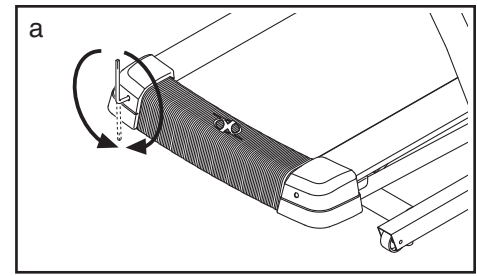

b. If the walking belt slips when walked on, first remove the key and **UNPLUG THE POWER CORD**. Using the hex key, turn both idler roller bolts clockwise, 1/4 of a turn. When the walking belt is correctly tightened, you should be able to lift each edge of the walking belt 3 to 4 in. (8 to 10 cm) off the walking platform. Be careful to keep the walking belt centered. Then, plug in the power cord, insert the key, and carefully walk on the incline trainer for a few minutes. Repeat until the walking belt is properly tightened.

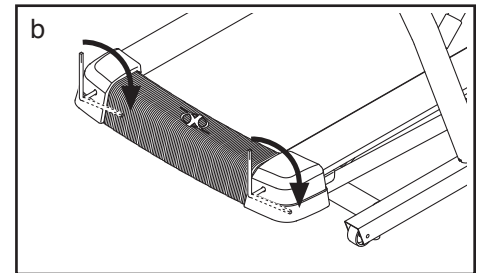

EXERCISE GUIDELINES

⚠️ WARNING: Before beginning any exercise program, consult your physician. This is especially important for persons over age 35 or persons with pre-existing health problems.

The pulse sensor is not a medical device. Various factors may affect the accuracy of heart rate readings. The pulse sensor is intended only as an exercise aid in determining heart rate trends in general.

These guidelines will help you to plan your exercise program. For detailed exercise information, obtain a reputable book or consult your physician. Remember, proper nutrition and adequate rest are essential for successful results.

EXERCISE INTENSITY

Whether your goal is to burn fat or to strengthen your cardiovascular system, exercising at the proper intensity is the key to achieving results. You can use your heart rate as a guide to find the proper intensity level. The chart below shows recommended heart rates for fat burning and aerobic exercise.

| | | | | | | | |
|-------|-----|-----|-----|-----|-----|-----|---|
| 165 | 155 | 145 | 140 | 130 | 125 | 115 | ♥ |
| 145 | 138 | 130 | 125 | 118 | 110 | 103 | ♥ |
| 125 | 120 | 115 | 110 | 105 | 95 | 90 | ♥ |
| <hr/> | | | | | | | |
| 20 | 30 | 40 | 50 | 60 | 70 | 80 | |

To find the proper intensity level, find your age at the bottom of the chart (ages are rounded off to the nearest ten years). The three numbers listed above your age define your “training zone.” The lowest number is the heart rate for fat burning, the middle number is the heart rate for maximum fat burning, and the highest number is the heart rate for aerobic exercise.

Burning Fat—To burn fat effectively, you must exercise at a low intensity level for a sustained period of time. During the first few minutes of exercise, your body uses *carbohydrate calories* for energy. Only after the first few minutes of exercise does your body begin to use stored *fat calories* for energy. If your goal is to burn fat, adjust the intensity of your exercise until your heart rate is near the lowest number in your training zone. For maximum fat burning, exercise with your heart rate near the middle number in your training zone.

Aerobic Exercise—If your goal is to strengthen your cardiovascular system, you must perform aerobic exercise, which is activity that requires large amounts of oxygen for prolonged periods of time. For aerobic exercise, adjust the intensity of your exercise until your heart rate is near the highest number in your training zone.

WORKOUT GUIDELINES

Warming Up—Start with 5 to 10 minutes of stretching and light exercise. A warm-up increases your body temperature, heart rate, and circulation in preparation for exercise.

Training Zone Exercise—Exercise for 20 to 30 minutes with your heart rate in your training zone. (During the first few weeks of your exercise program, do not keep your heart rate in your training zone for longer than 20 minutes.) Breathe regularly and deeply as you exercise—never hold your breath.

Cooling Down—Finish with 5 to 10 minutes of stretching. Stretching increases the flexibility of your muscles and helps to prevent post-exercise problems.

EXERCISE FREQUENCY

To maintain or improve your condition, complete three workouts each week, with at least one day of rest between workouts. After a few months of regular exercise, you may complete up to five workouts each week, if desired. Remember, the key to success is to make exercise a regular and enjoyable part of your everyday life.

SUGGESTED STRETCHES

The correct form for several basic stretches is shown at the right. Move slowly as you stretch—never bounce.

1. Toe Touch Stretch

Stand with your knees bent slightly and slowly bend forward from your hips. Allow your back and shoulders to relax as you reach down toward your toes as far as possible. Hold for 15 counts, then relax. Repeat 3 times. Stretches: Hamstrings, back of knees and back.

2. Hamstring Stretch

Sit with one leg extended. Bring the sole of the opposite foot toward you and rest it against the inner thigh of your extended leg. Reach toward your toes as far as possible. Hold for 15 counts, then relax. Repeat 3 times for each leg. Stretches: Hamstrings, lower back and groin.

3. Calf/Achilles Stretch

With one leg in front of the other, reach forward and place your hands against a wall. Keep your back leg straight and your back foot flat on the floor. Bend your front leg, lean forward and move your hips toward the wall. Hold for 15 counts, then relax. Repeat 3 times for each leg. To cause further stretching of the achilles tendons, bend your back leg as well. Stretches: Calves, achilles tendons and ankles.

4. Quadriceps Stretch

With one hand against a wall for balance, reach back and grasp one foot with your other hand. Bring your heel as close to your buttocks as possible. Hold for 15 counts, then relax. Repeat 3 times for each leg. Stretches: Quadriceps and hip muscles.

5. Inner Thigh Stretch

Sit with the soles of your feet together and your knees outward. Pull your feet toward your groin area as far as possible. Hold for 15 counts, then relax. Repeat 3 times. Stretches: Quadriceps and hip muscles.

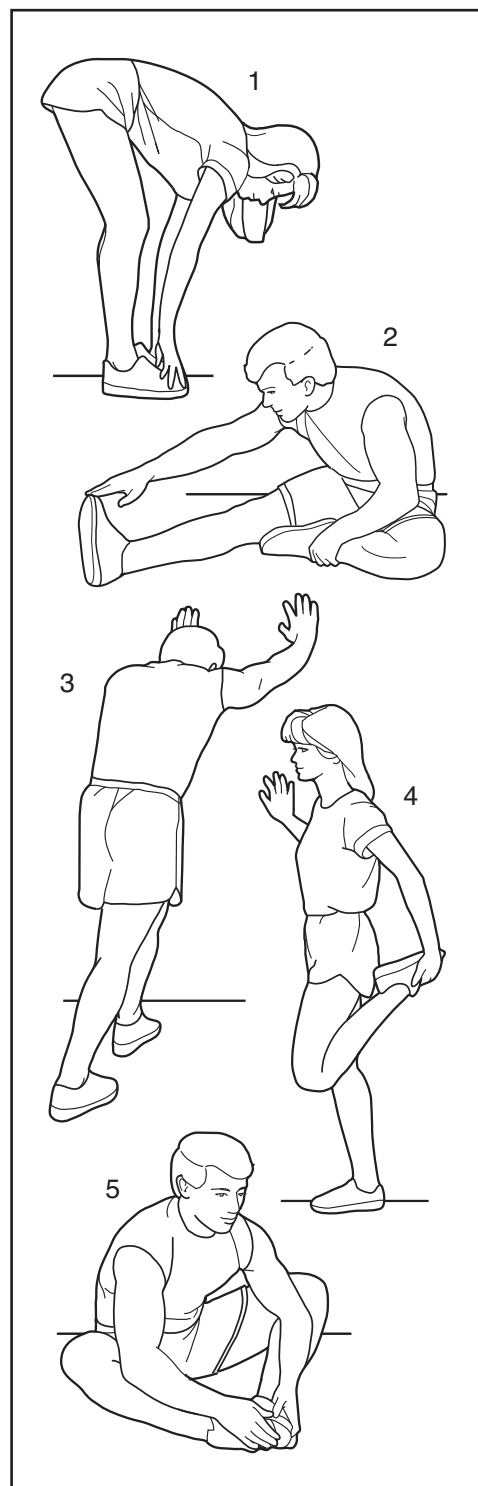

PART LIST—Model No. NTL15008.0

R1208C

To locate the parts listed below, see the EXPLODED DRAWING near the end of this manual.

| Key No. | Qty. | Description | Key No. | Qty. | Description |
|---------|------|---------------------------|---------|------|----------------------------|
| 1 | 37 | #8 x 3/4" Screw | 51 | 1 | Left Rear Cushion |
| 2 | 4 | #8 x 1" Tek Screw | 52 | 1 | Frame |
| 3 | 4 | 3/8" x 3 1/2" Bolt | 53 | 1 | Belly Pan Plate |
| 4 | 2 | 3/8" x 2 1/2" Bolt | 54 | 1 | Front Left Cushion |
| 5 | 1 | 72" Incline Motor Wire | 55 | 1 | Front Belly Pan |
| 6 | 4 | 5/16" x 3/4" Bolt | 56 | 1 | Top Incline Motor Cover |
| 7 | 2 | 3/8" x 5" Bolt | 57 | 1 | Bottom Incline Motor Cover |
| 8 | 2 | 3/8" Nut | 58 | 1 | Incline Motor |
| 9 | 8 | 3/8" Star Washer | 59 | 1 | Wire Clamp |
| 10 | 4 | #6 x 1" Screw | 60 | 1 | Electronics Plate |
| 11 | 12 | #8 x 3/4" Tek Screw | 61 | 4 | Plastic Stand-Off |
| 12 | 3 | #8 x 1/2" Screw | 62 | 1 | PCB Board |
| 13 | 1 | #8 x 3/4" Clamp Screw | 63 | 1 | Controller |
| 14 | 4 | Belt Guide Screw | 64 | 1 | Drive Motor |
| 15 | 2 | 1/4" x 1 1/2" Screw | 65 | 1 | Resistance Mechanism |
| 16 | 2 | 5/16 x 1 1/4" Bolt | 66 | 4 | Pulse Plate |
| 17 | 2 | 5/16 x 1 3/4" Bolt | 67 | 4 | Pulse Plate Housing |
| 18 | 2 | 1/4" x 2 1/2" Bolt | 68 | 2 | Pulse Handle |
| 19 | 1 | 3/8" x 1" Bolt | 69 | 1 | Left Handrail |
| 20 | 1 | 3/8" x 1 3/4" Bolt | 70 | 1 | Left Pulse Wire |
| 21 | 2 | 3/8" x 4 1/4" Bolt | 71 | 1 | Right Pulse Wire |
| 22 | 13 | #8 x 1/2" Screw | 72 | 1 | Upright Wire |
| 23 | 5 | Motor Bolt | 73 | 1 | Console Cover |
| 24 | 7 | #8 Star Washer | 74 | 1 | Upright |
| 25 | 2 | 1/4" Flat Washer | 75 | 1 | Right Handrail |
| 26 | 2 | 1/4" Lock Washer | 76 | 2 | Handrail Cover |
| 27 | 2 | 1/4" Star Washer | 77 | 2 | Wheel |
| 28 | 2 | 3/8" Lock Nut | 78 | 1 | Base |
| 29 | 2 | 5/16" Flange Nut | 79 | 4 | Base Foot Spacer |
| 30 | 15 | Clip | 80 | 4 | Base Foot |
| 31 | 2 | Plastic Fastener | 81 | 2 | Caution Decal |
| 32 | 4 | 1/4" x 1" Bolt | 82 | 1 | Warning Decal |
| 33 | 1 | Hex Key | 83 | 2 | Base Cap |
| 34 | 1 | 5/32" Hex Key | 84 | 1 | Console |
| 35 | 1 | Left Roller Cover | 85 | 1 | Console Fan |
| 36 | 1 | Right Roller Cover | 86 | 1 | Accessory Tray |
| 37 | 1 | Magnet | 87 | 1 | Yoke Spacer |
| 38 | 1 | Drive Roller/Pulley | 88 | 1 | Yoke |
| 39 | 1 | Belly Pan | 89 | 1 | Console Ground Wire |
| 40 | 2 | Belt Guide | 90 | 1 | Access Door |
| 41 | 1 | Walking Platform | 91 | 1 | Key/Clip |
| 42 | 1 | Walking Belt | 92 | 2 | #8 x 1/2" Cover Screw |
| 43 | 1 | Idler Roller | 93 | 1 | Motor Belt |
| 44 | 1 | Front Hood | 94 | 1 | Left Platform Decal |
| 45 | 1 | Power Cord | 95 | 1 | Right Platform Decal |
| 46 | 1 | Grommet | 96 | 1 | Right Front Cushion |
| 47 | 1 | Belly Pan Cover | 97 | 1 | Right Rear Cushion |
| 48 | 1 | Reset/Off Circuit Breaker | 98 | 2 | 8" Cable Tie |
| 49 | 1 | Reed Switch | 99 | 8 | 8" Wire Tie |
| 50 | 1 | Reed Switch Clamp | 100 | 3 | Round Grommet |

| Key No. | Qty. | Description | Key No. | Qty. | Description |
|---------|------|------------------------|---------|------|--------------------|
| 101 | 1 | 70" Incline Motor Wire | * | — | 4" Blue Wire, M/F |
| 102 | 1 | Motor Shield | * | — | 6" Black Wire, M/F |
| 103 | 1 | Audio Wire | * | — | 4" Red Wire, M/F |
| * | — | 8" White Wire, M/F | * | — | 10" Red Wire, 2F |
| * | — | 10" Blue Wire, 2F | * | — | User's Manual |

Note: Specifications are subject to change without notice. See the back cover of this manual for information about ordering replacement parts. *These parts are not illustrated.

EXPLODED DRAWING A—Model No. NTL15008.0

R1208C

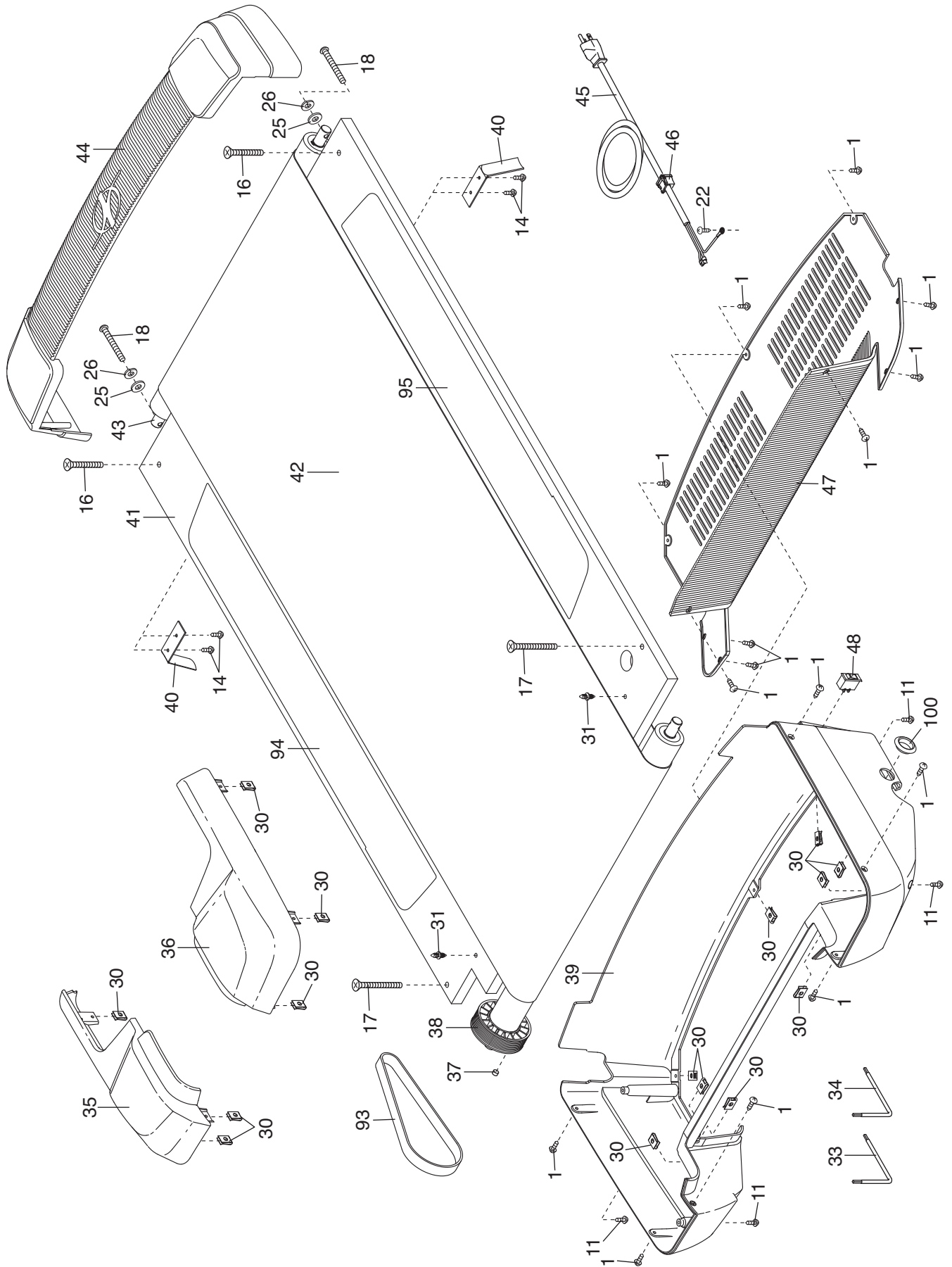

EXPLODED DRAWING B—Model No. NTL15008.0

R1208C

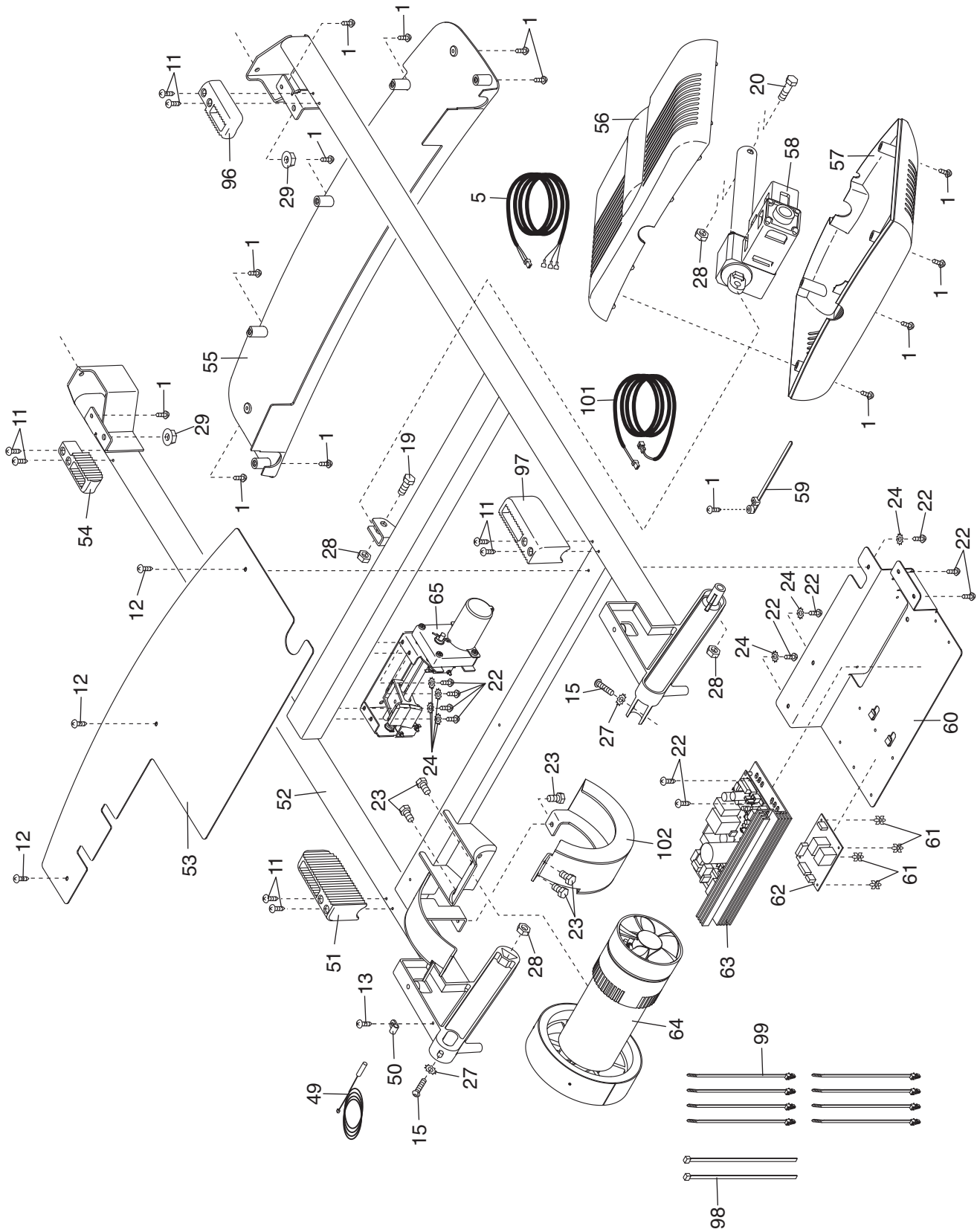

EXPLODED DRAWING C—Model No. NTL15008.0

R1208C

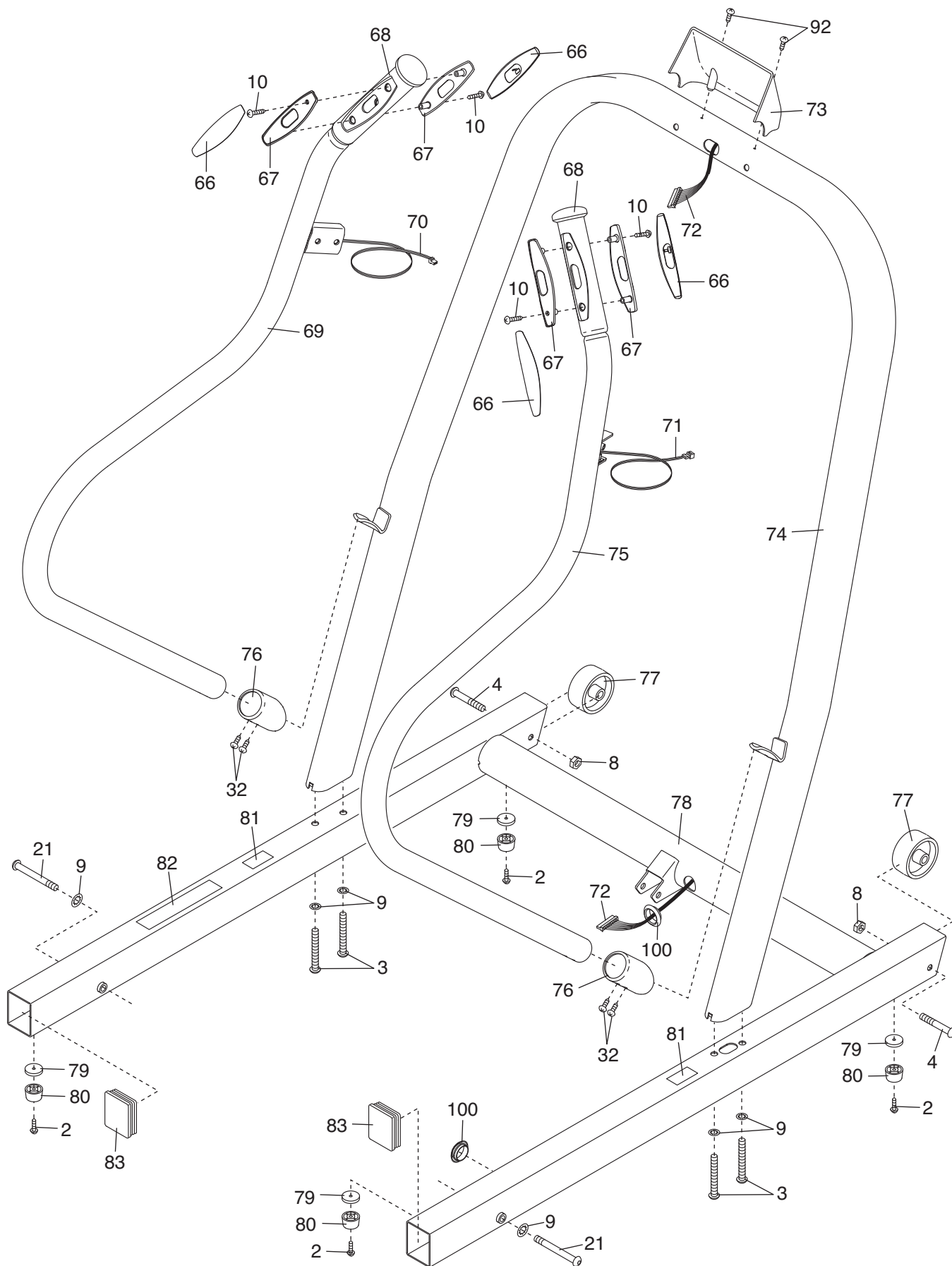

EXPLODED DRAWING D—Model No. NTL15008.0

R1208C

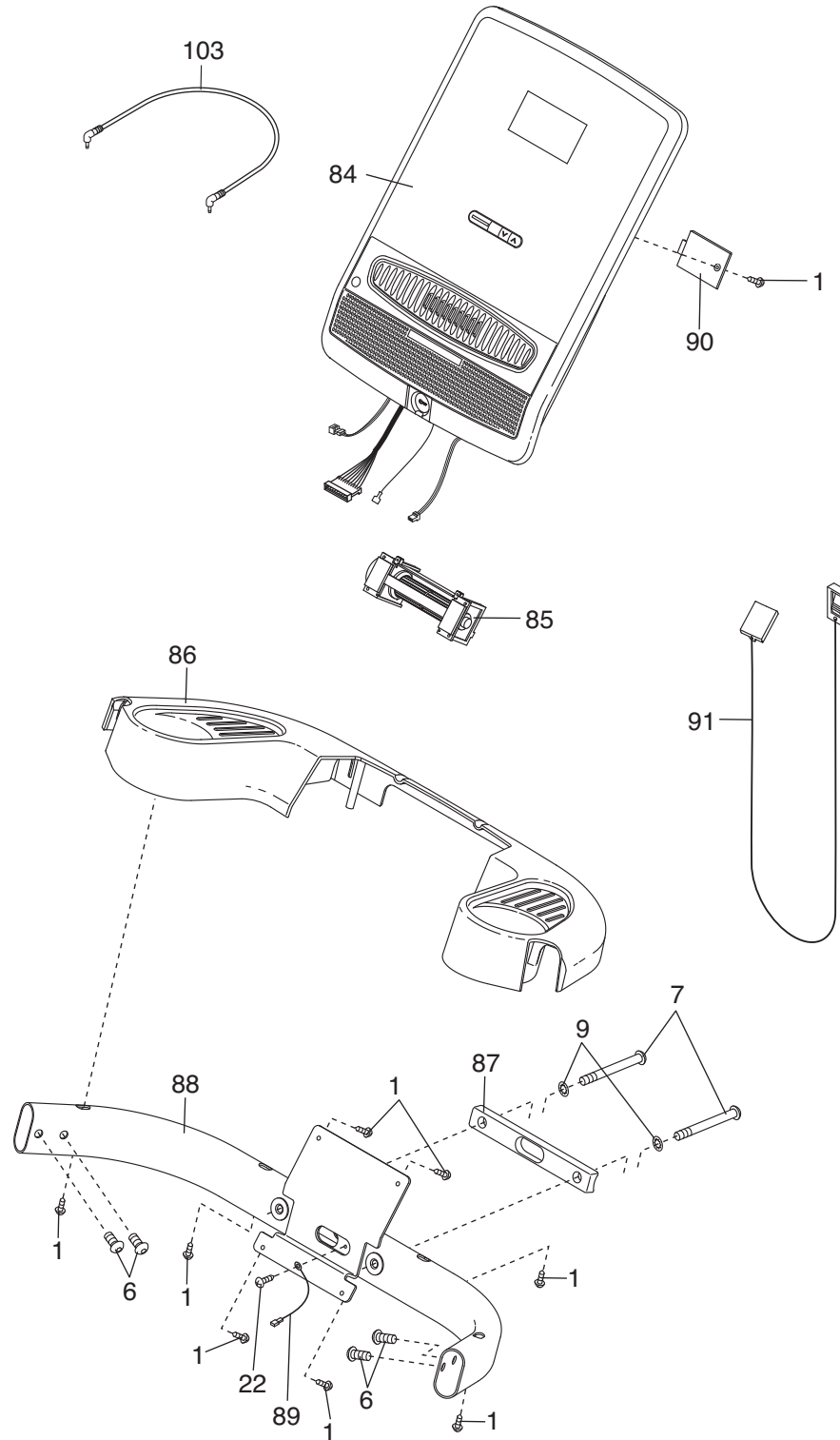

ORDERING REPLACEMENT PARTS

To order replacement parts, please see the front cover of this manual. To help us assist you, be prepared to provide the following information when contacting us:

- the model number and serial number of the product (see the front cover of this manual)
- the name of the product (see the front cover of this manual)
- the key number and description of the replacement part(s) (see the PART LIST and the EXPLODED DRAWING near the end of this manual)

LIMITED WARRANTY

ICON Health & Fitness, Inc. (ICON) warrants this product to be free from defects in workmanship and material, under normal use and service conditions. The frame and drive motor are warranted for a lifetime. Parts and labor are warranted for one (1) year from the date of purchase.

This warranty extends only to the original purchaser. ICON's obligation under this warranty is limited to repairing or replacing, at ICON's option, the product through one of its authorized service centers. All repairs for which warranty claims are made must be preauthorized by ICON. If the product is shipped to a service center, freight charges to and from the service center will be the customer's responsibility. For replacement parts shipped while the product is under warranty, the customer will be responsible for a minimal handling charge. For in-home service, the customer will be responsible for a minimal trip charge. This warranty does not extend to any damage to a product caused by or attributable to freight damage, abuse, misuse, improper or abnormal usage, or repairs not provided by an ICON authorized service center; products used for commercial or rental purposes; or products used as store display models. No other warranty beyond that specifically set forth above is authorized by ICON.

ICON is not responsible or liable for indirect, special, or consequential damages arising out of or in connection with the use or performance of the product; damages with respect to any economic loss, loss of property, loss of revenues or profits, loss of enjoyment or use, or costs of removal or installation; or other consequential damages of whatsoever nature. Some states do not allow the exclusion or limitation of incidental or consequential damages. Accordingly, the above limitation may not apply to you.

The warranty extended hereunder is in lieu of any and all other warranties, and any implied warranties of merchantability or fitness for a particular purpose are limited in their scope and duration to the terms set forth herein. Some states do not allow limitations on how long an implied warranty lasts. Accordingly, the above limitation may not apply to you.

This warranty gives you specific legal rights. You may also have other rights that vary from state to state.

ICON Health & Fitness, Inc., 1500 S. 1000 W., Logan, UT 84321-9813